

PRODUKTKATALOG

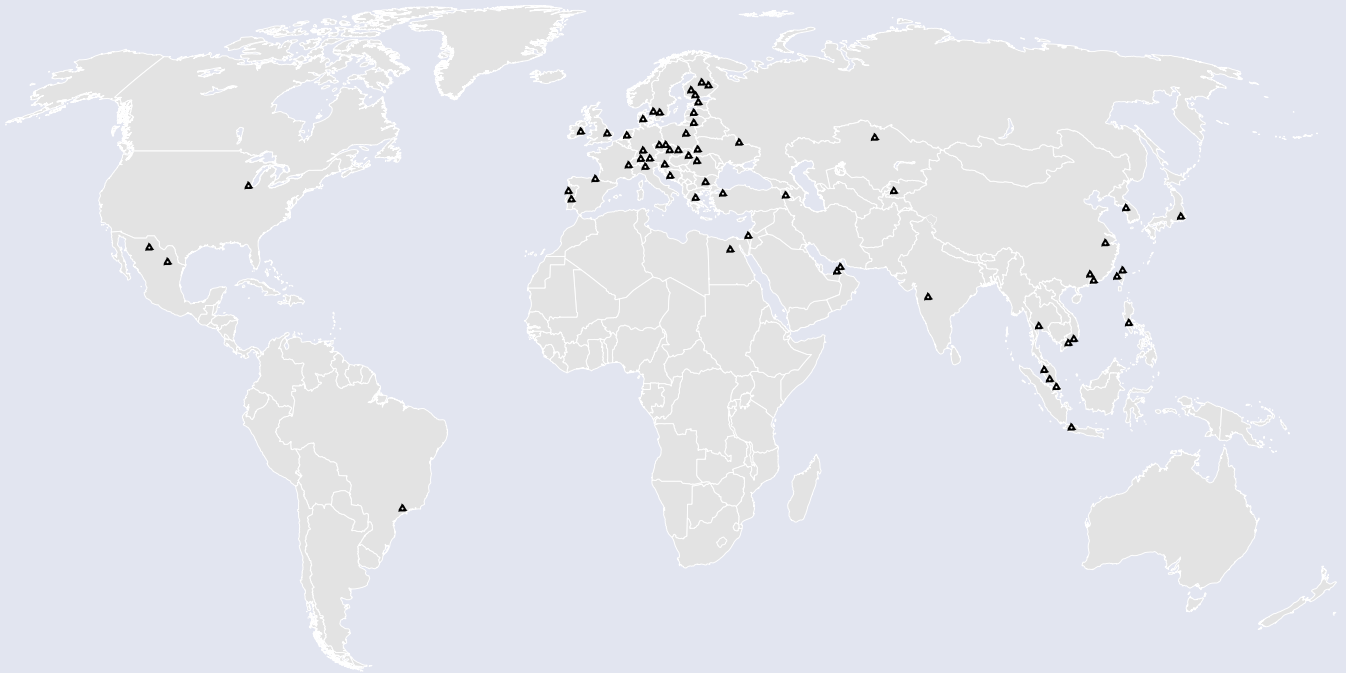

WELTWEIT FÜR SIE DA



Allgemein / general:

mail: info@duemmel.de
Telefon: 0049 (0) 7125/9691-0
Telefax: 0049 (0) 7125/9691-50

**Anfragen und
Technische Beratung:
inquiries and
technical consulting:**

mail: angebote@duemmel.de
mail: offer@duemmel.de

**Bestellungen:
orders:**

mail: bestellungen@duemmel.de
mail: order@duemmel.de

**Ihr persönlicher Ansprechpartner:
your personal contact partner:**

**Ihre Kundennummer:
your customer number:**

BESUCHEN SIE UNS AUCH IM INTERNET
PLEASE VISIT US ONLINE

www.duemmel.de



Lieber Kunde,

im sich ständig wechselnden Umfeld der Metallbearbeitung sind wir für Sie als Firma - und Familie Dümmel seit mittlerweile fast 100 Jahren ein verlässlicher Partner. Neben der herausragenden Qualität unserer Werkzeuge haben wir in den letzten Jahren unser Werkzeugprogramm konsequent erweitert. Getreu dem Motto, Standard statt Sonder, bieten wir Ihnen mittlerweile fast 13.000 Standardwerkzeuge ab Lager an.

Damit Sie auch kurzfristige Planungen realisieren können, bieten wir Ihnen die Möglichkeit, bei einer Bestellung bis spätestens 17:00 Uhr diese noch am gleichen Tag zu versenden, wenn möglich auch mit einer Zustellung am nächsten Morgen.

Mit der Entscheidung Dümmel Werkzeuge einzusetzen, haben Sie die optimale Kombination von Performance, Qualität und Schnelligkeit, gepaart mit der generationenübergreifenden Konstanz eines Familienunternehmens.

Dear Customer,

in the constantly changing environment of metal processing, we as a company and the Dümmel family have been a reliable partner for you for almost 100 years. In addition to the outstanding quality of our tools, we have consistently expanded our tool program in recent years. True to the motto, standard instead of special, we now offer you almost 13.000 standard tools from stock.

So that you can also implement short-term planning, we offer you the option of having your order sent by 5:00 p.m. at the latest on the same day, with delivery the next morning if possible.

By deciding to use Dümmel tools, you have the optimal combination of performance, quality and speed, coupled with the cross-generational consistency of a family business.



*Karl-Heinz Duemmel
Geschäftsführer
dritte Generation*



*Jochen M. Duemmel
Geschäftsführer
vierte Generation*



PRODUKTÜBERSICHT

PRODUCT OVERVIEW



Drehen
turning

Fräsen
milling

Bohren
drilling

Drehen turning

Inhalt
content

	ULTRAMINI	ULTRAMINI	D min. $\geq \varnothing 0.2$ mm	01	
	MINICUT	MINICUT TRICUT	D min. $\geq \varnothing 7.0$ mm D min. $\geq \varnothing 7.8$ mm	02	
	MF TOOLS	Typ DT Typ DT MAX	D min. $\geq \varnothing 2.00$ mm D min. $\geq \varnothing 7.85$ mm	03	
	SWISSLINE	SWISSLINE	b ≥ 0.5 mm	04	
	STECHDREH- WERKZEUGE	SYSTEM DED SYSTEM D-GROOVING	S ≥ 0.5 mm b ≥ 2.0 mm	05	
	NUTSTOSSEN	NUTSTOSSEN	B ≥ 2.0 mm D min. $\geq \varnothing 6.0$ mm SW ≥ 1.0 mm	06	

Fräsen milling

Inhalt content

	FM-LINE	FM-LINE	$DS \geq \varnothing 0.2 \text{ mm}$	07	
	MIKROMILL	MIKROMILL $D \text{ min.} \geq \varnothing 4.0 \text{ mm}$ Gewinde- $\varnothing \geq 1.0 \times 0,25 \text{ mm}$ thread- $\varnothing \geq 1.0 \times 0,25 \text{ mm}$	$DS \geq \varnothing 12.5 \text{ mm}$	08	
	MINIMILL	MINIMILL MINIMILL XL	$D \text{ min.} \geq \varnothing 7.0 \text{ mm}$ $DS = \varnothing 50 \text{ mm}$	09	
	SYSTEM 500	SYSTEM 500	$DS \geq \varnothing 44 \text{ mm}$ $D \text{ min.} \geq \varnothing 45 \text{ mm}$ $b \geq 1.41 \text{ mm}$	10	
	ROTALINE	ROTALINE	$D \text{ min.} \geq \varnothing 0.4 \text{ mm}$	11	
	AXALINE	AXALINE	$D \text{ min.} \geq \varnothing 5.0 \text{ mm}$	12	

Bohren drilling

Inhalt
content



BM-LINE

BM-LINE

D ≥ Ø 0.8 mm
Bohrungstiefen ≤ 30 x D
Drilling depths ≤ 30 x D

13





duemmel.de



ULTRAMINI

D min. $\geq \varnothing 0.2$ mm

ULTRAMINI

Bohrungsbearbeitung
ab Ø 0.2 mm

grooving, boring and profiling
starting at Ø 0.2 mm

Übersicht

summary

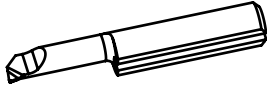

Allgemeine Beschreibung

general instruction

... 24

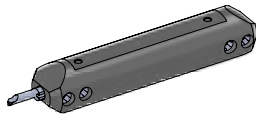

**Klemmhalter
Rundschaft**

**toolholder
straight shank**

**Maße
dimensions
[mm]**

**Seite
page**

Typ 645	Klemmhalter	toolholder	Ø 12 - 28 D min. 0.2 - 5.0	... 28
Typ 645.PT	Klemmhalter, Premiumline mit verbesserter Kühlung	toolholder, Premiumline with improved cooling	Ø 12 - 28 D min. 0.2 - 5.0	... 29
Typ 676	Klemmhalter	toolholder	Ø 16 - 28 D min. 6.0 - 7.0	... 30
Typ 676.PT	Klemmhalter, Premiumline mit verbesserter Kühlung	toolholder, Premiumline with improved cooling	Ø 15.87 - 28 D min. 6.0 - 7.0	... 31
Typ 687 / 681	Klemmhalter	toolholder	Ø 16 - 25.4 D min. 6.8 - 7.8 / D min. 7.8 - 10.5	... 32
Typ 687.PT	Klemmhalter, Premiumline mit verbesserter Kühlung	toolholder, Premiumline with improved cooling	Ø 16 - 20 D min. 6.8 - 7.8	... 33
Typ 640 / 650 / 660 / 670 / 680	Klemmhalter	toolholder	Ø 12 / 12.7 D min. 0.2 - 7.8	... 34
Typ 640.DT / 650.DT	Klemmhalter	toolholder	Ø 12 - 25.4 D min. 0.2 - 5.0	... 35
Typ 640P.DT / 650P.DT	Klemmhalter, durch tiefere Werkzeugspannung optimiert für Schneideinsatz Typ DT	toolholder, by deeper insert clamping optimized for insert type DT	Ø 12 - 25.4 D min. 2.9 - 4.7	... 36
Typ 660.DT / 670.DT	Klemmhalter	toolholder	Ø 12 - 25.4 D min. 6.0 - 7.0	... 37
Typ 660P.DT / 670P.DT	Klemmhalter, durch tiefere Werkzeugspannung optimiert für Schneideinsatz Typ DT	toolholder, by deeper insert clamping optimized for insert type DT	Ø 12 - 25.4 D min. 5.7 - 6.7	... 38

↳ ...

ULTRAMINI

Bohrungsbearbeitung
ab \varnothing 0.2 mm

grooving, boring and profiling
starting at \varnothing 0.2 mm

Übersicht

summary

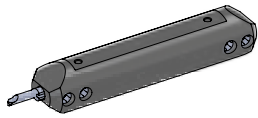

**Klemmhalter
Rundschaft**

**toolholder
straight shank**

**Maße
dimensions
[mm]**

**Seite
page**



... ↴

Typ 680.DT	Klemmhalter	toolholder	\varnothing 12 - 25.4 D min. 7.8	... 39
Typ 680P.DT	Klemmhalter, durch tiefere Werkzeugspannung optimiert für Schneideinsatz Typ DT	toolholder, by deeper insert clamping optimized for insert type DT	\varnothing 12 - 25.4 D min. 7.7	... 40
Typ UM.RBD12.00	Klemmhalter und Reduzierhülse lange Ausführung, mit Kühlmittelanschluss	toolholder and reduction bush long version, with coolant connection	\varnothing 16 - 25.4 D min. \geq 0.2	... 41
Typ UM.RBD12.00	Klemmhalter und Reduzierhülse kurze Ausführung, mit Kühlmittelanschluss	toolholder and reduction bush short version, with coolant connection	\varnothing 19.05 - 25.4 D min. \geq 0.2	... 42
TYP UMST	Klemmhalter, mit Hochdruckanschluss für Langdreher	toolholder, with high-pressure connection for Swiss type Machines	\varnothing 16 - 28 D min. 0.2 - 7.8	... 43
Typ UM600H	High-Performance-Klemmhalter, mit Kühlmittelanschluss	high-performance toolholder, with coolant connection	\varnothing 12 - 28 D min. 0.2 - 7.0	... 45
Typ UM600H.S	High-Performance-Klemmhalter, kurze Ausführung mit Kühlmittelanschluss	high-performance toolholder, short version with coolant connection	\varnothing 16 - 25.4 D min. 0.2 - 7.0	... 48

ULTRAMINI

Bohrungsbearbeitung
ab \varnothing 0.2 mm

grooving, boring and profiling
starting at \varnothing 0.2 mm

Übersicht

summary

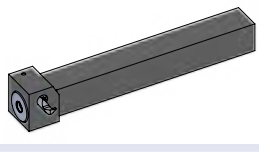
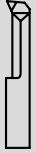

**Klemmhalter
Quadratschaft und
Rechteckschaft**

**toolholder
square shank and
rectangle shank**

**Maße
dimensions
[mm]**

**Seite
page**

Typ UM	Klemmhalter, Quadratschaft	toolholder, square shank	ab / starting at 10 x 10 D min. 0.2 - 7.0	... 51
Typ .IK.UHCM	Klemmhalter, Quadratschaft, mit Innenkühlung	toolholder, square shank, with internal cooling	ab / starting at 12 x 12 D min. 0.2 - 7.0	... 52
Typ .UM.18 / .UM.28	Klemmhalter, Quadratschaft, mit Innenkühlung	toolholder, square shank, with internal cooling	10 x 10 D min. 0.2 - 7.0	... 54
Typ .UM.18 / .UM.28	Klemmhalter, Quadratschaft, mit Innenkühlung	toolholder, square shank, with internal cooling	12 x 12 D min. 0.2 - 7.0	... 55
Typ .TD0710	Klemmhalter, Rechteckschaft für Tornos DECO 7/10	toolholder, rectangle shank for Tornos DECO 7/10	25 x 26 D min. 0.2 - 7.0	... 56

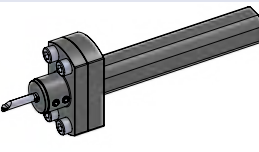

**Klemmhalter und Reduzierhülse
für Rückseitenbearbeitung
auf Langdrehautomaten**

**toolholder and reduction bush
for rear end machining
on Swiss type lathes**

**Maße
dimensions
[mm]**

**Seite
page**

Typ UMHB	Klemmhalter und Reduzierhülse für Rückseitenbearbeitung auf Langdrehautomaten	toolholder and reduction bush for rear end machining on Swiss type lathes	D min. \geq 0.2	... 57
Typ UM.WFB	Klemmhalter und Reduzierhülse mit WFB - Aufnahme	toolholder and reduction bush with WFB - adapter	D min. \geq 0.2	... 58
Typ UM.C	Klemmhalter und Reduzierhülse mit Polygonschaft nach ISO 26623	toolholder and reduction bush with polygon shank according to ISO 26623	C3; C4 D min. \geq 0.2	... 59
Typ UMHV	Höhenverstellbarer Klemmhalter und Reduzierhülse für Rückseiten- bearbeitung auf Langdrehautomaten	height adjustable toolholder and reduction bush for rear end machining on Swiss type lathes	D min. \geq 0.2	... 60

ULTRAMINI

Bohrungsbearbeitung
ab \varnothing 0.2 mm

grooving, boring and profiling
starting at \varnothing 0.2 mm

Übersicht

summary

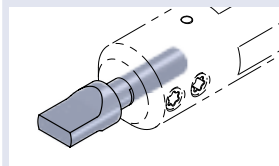

Zubehör

accessory

Maße
dimensions
[mm]

Seite
page



Typ UM.MASTER.

Ausrichthilfe für Klemmhalter

adjustment insert for toolholder

\varnothing 4 - 8

... 61

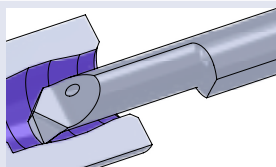

Schneideinsätze Ausdrehen und Kopieren

inserts boring and profiling

Maße
dimensions
[mm]

Seite
page

Typ 050

Ausdrehen und Kopieren

boring and profiling

D min. 0.2 - 9.8

... 63

Performanceline Typ P50

Ausdrehen und Kopieren
mit innerer Kühlmittelzufuhr

boring and profiling
with through coolant

D min. 2.0 - 6.8

... 68

Superfinish Typ F050

Ausdrehen für
perfekte Oberflächen

boring for
perfect surface quality

D min. 4.0 - 6.8

... 71

Typ 050.20

Ausdrehen und Kopieren
mit Geometrie 20° / 20°

boring and profiling
with geometry 20° / 20°

D min. 2.0 - 5.0

... 72

Performanceline Typ P50.20

Ausdrehen und Kopieren
mit Geometrie 20° / 20°
und innerer Kühlmittelzufuhr

boring and profiling
with geometry 20° / 20°
and through coolant

D min. 2.0 - 5.0

... 73

Typ 053

Ausdrehen und Kopieren
mit Eckenradius 0.03 mm

boring and profiling
with corner radius 0.03 mm

D min. 2.8 - 4.0

... 74

Performanceline Typ P53

Ausdrehen und Kopieren
mit Eckenradius 0.03 mm
und innerer Kühlmittelzufuhr

boring and profiling
with corner radius 0.03 mm
and through coolant

D min. 2.8 - 4.0

... 75

Typ 055

Ausdrehen und Kopieren
mit Eckenradius 0.05 mm

boring and profiling
with corner radius 0.05 mm

D min. 2.0 - 6.0

... 76

Performanceline Typ P55

Ausdrehen und Kopieren
mit Eckenradius 0.05 mm
und innerer Kühlmittelzufuhr

boring and profiling
with corner radius 0.05 mm
and through coolant

D min. 2.0 - 6.0

... 78

Typ 050...B

Ausdrehen und Kopieren
mit innerer Kühlmittelzufuhr

boring and profiling
with through coolant

D min. 6.0 - 6.8

... 80

↳ ...

ULTRAMINI

Bohrungsbearbeitung
ab \varnothing 0.2 mm

grooving, boring and profiling
starting at \varnothing 0.2 mm

Übersicht

summary

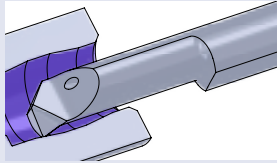
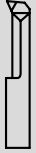

Schneideinsätze
Ausdrehen und Kopieren

inserts
boring and profiling

Maße
dimensions
[mm]

Seite
page

... ↴

Typ 050...C	Ausdrehen und Kopieren mit Spantreppe für bessere Spankontrolle	boring and profiling with chipbreaker for better chipcontrol	D min. 2.0 - 6.8	... 81
Performanceline Typ P50...C	Ausdrehen und Kopieren mit Spantreppe für bessere Spankontrolle und innerer Kühlmittelzufuhr	boring and profiling with chipbreaker for better chipcontrol and through coolant	D min. 2.0 - 6.8	... 83
Mediline Typ M050	Ausdrehen und Kopieren mit innerer Kühlmittelzufuhr und modifizierter Geometrie	boring and profiling with through coolant and modified profile	D min. 0.5 - 4.0	... 85
Xtraline Typ X050	Ausdrehen und Kopieren mit innerer Kühlmittelzufuhr, Spantreppe, extra stabile Ausführung	boring and profiling with through coolant, chipbreaker and extra solid construction	D min. 1.0 - 7.0	... 87
Hardline Typ 050	Ausdrehen und Kopieren, Hartbearbeitung bis 66 HRC	boring and profiling, hard machining up to 66 HRC	D min. 2.0 - 6.8	... 92
Typ 050.../CBN	Ausdrehen und Kopieren, für Hartbearbeitung	boring and profiling, for hard machining	D min. 1.0 - 6.8	... 94
Typ 047	Ausdrehen und Kopieren mit Geometrie 47° / 8°	boring and profiling with geometry 47° / 8°	D min. 2.0 - 6.0	... 96
Performanceline Typ P47	Ausdrehen und Kopieren mit Geometrie 47° / 8° und innerer Kühlmittelzufuhr	boring and profiling with geometry 47° / 8° and through coolant	D min. 2.0 - 6.0	... 97
Typ 090	Ausdrehen und Kopieren mit Geometrie 20° / 90°	boring and profiling with geometry 20° / 90°	D min. 2.8 - 6.0	... 98
Performanceline Typ P90	Ausdrehen und Kopieren mit Geometrie 20° / 90° und innerer Kühlmittelzufuhr	boring and profiling with geometry 20° / 90° and through coolant	D min. 2.8 - 5.0	... 99

ULTRAMINI

Bohrungsbearbeitung
ab \varnothing 0.2 mm

grooving, boring and profiling
starting at \varnothing 0.2 mm

Übersicht

summary

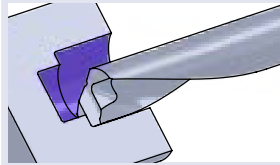

**Schneideinsätze
Bohren und
Ausdrehen**

**inserts
drilling and
boring**

**Maße
dimensions
[mm]**

**Seite
page**

Typ DT

Bohren und Ausdrehen

drilling and boring

D min. 2.0 - 7.7

... **100**

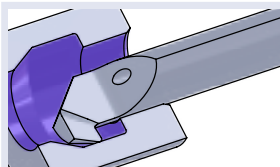

**Schneideinsätze
Rückwärtsdrehen**

**inserts
backboring**

**Maße
dimensions
[mm]**

**Seite
page**

Typ 080

Rückwärtsdrehen

backboring

D min. 3.0 - 7.0

... **103**

Performanceline
Typ P80

Rückwärtsdrehen
mit innerer Kühlmittelzufuhr

backboring
with through coolant

D min. 3.0 - 7.0

... **104**



ULTRAMINI

Bohrungsbearbeitung
ab \varnothing 0.2 mm

grooving, boring and profiling
starting at \varnothing 0.2 mm

Übersicht

summary

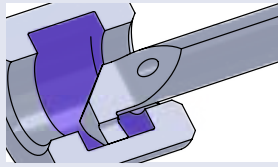
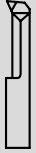

Schneideinsätze Stechdrehen

inserts grooving

Maße dimensions [mm]

Seite page

Typ 001 / 0015	Stechdrehen	grooving	D min. 1.0 / 1.5 t max. 0.2 / 0.4	... 106
Typ 002	Stechdrehen	grooving	D min. 2.0 t max. 0.4	... 107
Typ 003	Stechdrehen	grooving	D min. 3.0 t max. 0.6	... 108
Typ 004	Stechdrehen	grooving	D min. 4.0 t max. 0.8	... 109
Typ 004M	Stechdrehen mit Eckenradius	grooving with corner radius	D min. 4.0 t max. 0.8	... 110
Performanceline Typ P04M	Stechdrehen mit Eckenradius und innerer Kühlmittelzufuhr	grooving with corner radius and through coolant	D min. 4.0 t max. 0.8	... 111
Typ 005	Stechdrehen	grooving	D min. 5.0 t max. 1.0	... 112
Typ 005M	Stechdrehen mit Eckenradius	grooving with corner radius	D min. 5.0 t max. 1.0	... 114
Performanceline Typ P05M	Stechdrehen mit Eckenradius und innerer Kühlmittelzufuhr	grooving with corner radius and through coolant	D min. 5.0 t max. 1.0	... 116
Typ 006	Stechdrehen	grooving	D min. 6.0 t max. 1.8	... 118
Typ 006M	Stechdrehen mit Eckenradius	grooving with corner radius	D min. 6.0 t max. 1.8	... 120
Performanceline Typ P06M	Stechdrehen mit Eckenradius und innerer Kühlmittelzufuhr	grooving with corner radius and through coolant	D min. 6.0 t max. 1.8	... 122

↳ ...

ULTRAMINI

Bohrungsbearbeitung
ab \varnothing 0.2 mm

grooving, boring and profiling
starting at \varnothing 0.2 mm

Übersicht

summary

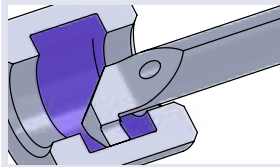

**Schneideinsätze
Stechdrehen**

**inserts
grooving**

**Maße
dimensions
[mm]**

**Seite
page**



... ↴

Typ 007	Stechdrehen	grooving	D min. 6.8 t max. 2.5	... 124
Typ 007M	Stechdrehen mit Eckenradius	grooving with corner radius	D min. 6.8 t max. 2.5	... 126
Performanceline Typ P07M	Stechdrehen mit Eckenradius und innerer Kühlmittelzufuhr	grooving with corner radius and through coolant	D min. 6.8 t max. 2.5	... 128
Typ 008M	Stechdrehen mit Eckenradius	grooving with corner radius	D min. 7.8 t max. 3.0	... 130
Typ 10M	Stechdrehen mit Eckenradius und innerer Kühlmittelzufuhr	grooving with corner radius and through coolant	D min. 10.5 t max. 4.0	... 131
Typ 004 / 005 / 006 / 007	Stechdrehen und Kopieren mit Vollradius	grooving and profiling with full radius	D min. 4.0 R 0.5 - 1.0	... 132
Performanceline Typ P04 / P05 / P06 / P07	Stechdrehen und Kopieren mit Vollradius und innerer Kühlmittelzufuhr	grooving and profiling with full radius and through coolant	D min. 4.0 R 0.5 - 1.0	... 133
Typ 060	Ausdrehen und Fasen	boring and chamfering	D min. 3.0 - 6.8	... 134
Performanceline Typ P60	Ausdrehen und Fasen mit innerer Kühlmittelzufuhr	boring and chamfering with through coolant	D min. 3.0 - 6.8	... 135
Typ 070	Vorstechen und Fasen	pregrooving and chamfering	D min. 4.0 - 6.0	... 136
Performanceline Typ P70	Vorstechen und Fasen mit innerer Kühlmittelzufuhr	pregrooving and chamfering with through coolant	D min. 4.0 - 6.0	... 137

ULTRAMINI

Bohrungsbearbeitung
ab \varnothing 0.2 mm

grooving, boring and profiling
starting at \varnothing 0.2 mm

Übersicht

summary

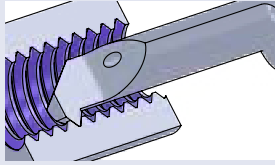

**Schneideinsätze
Gewindedrehen, innen**

**inserts
threading, internal**

**Maße
dimensions
[mm]**

**Seite
page**

Typ Gewindedrehen	metrisches ISO-Gewinde, Teilprofil, innen	type threading, metric ISO-thread, partial profile, internal	D min. 0.73 - 7.0 P = 0.25 - 1.75	... 139
Performanceline Typ Gewindedrehen	metrisches ISO-Gewinde, Teilprofil, innen mit innerer Kühlmittelzufuhr	type threading, metric ISO-thread, partial profile, internal with through coolant	D min. 1.56 - 7.0 P = 0.4 - 1.75	... 142
Typ Gewindedrehen	metrisches ISO-Gewinde, Vollprofil, innen	type threading, metric ISO-thread, full profile, internal	D min. 2.4 - 7.0 P = 0.5 - 1.5	... 145
Performanceline Typ Gewindedrehen	metrisches ISO-Gewinde, Vollprofil, innen mit innerer Kühlmittelzufuhr	type threading, metric ISO-thread, full profile, internal with through coolant	D min. 4.0 - 7.0 P = 0.5 - 1.5	... 147
Typ Gewindedrehen	UN-Gewinde, Teilprofil, innen	UN-thread, partial profile, internal	D min. 4.0 D min. 5.0 D min. 6.0	... 148
Typ Gewindedrehen	Whitworth-Gewinde, Teilprofil, innen	type threading, Whitworth thread, partial profile, internal	D min. 4.8 - 7.0	... 149
Performanceline Typ Gewindedrehen	Whitworth-Gewinde, Teilprofil, innen mit innerer Kühlmittelzufuhr	type threading, Whitworth thread, partial profile, internal with through coolant	D min. 4.8 - 7.0	... 150
Typ Gewindedrehen	Whitworth-Gewinde, Vollprofil, innen	type threading, Whitworth thread, full profile, internal	D min. 6.0	... 151
Performanceline Typ Gewindedrehen	Whitworth-Gewinde, Vollprofil, innen mit innerer Kühlmittelzufuhr	type threading, Whitworth thread, full profile, internal with through coolant	D min. 6.0	... 152

↳ ...

ULTRAMINI

Bohrungsbearbeitung
ab $\varnothing 0.2 \text{ mm}$

grooving, boring and profiling
starting at $\varnothing 0.2 \text{ mm}$

Übersicht

summary

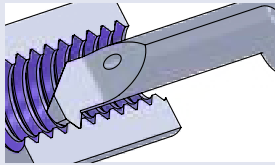

Schneideinsätze
Gewindedrehen, innen

inserts
threading, internal

Maße
dimensions
[mm]

Seite
page



... ↴

Typ Gewindedrehen

NPT-Gewinde,
Teilprofil, innen

type threading,
NPT thread,
partial profile, internal

D min. 6.0

... 153

Performanceline
Typ Gewindedrehen

NPT-Gewinde,
Teilprofil, innen
mit innerer Kühlmittelzufuhr

type threading,
NPT thread,
partial profile, internal
with through coolant

D min. 6.0

... 154

Typ Gewindedrehen

Trapezgewinde,
Teilprofil, innen

type threading,
trapezoidal thread,
partial profile, internal

D min. 7.0
P = 2.0 - 3.0

... 155

Performanceline
Typ Gewindedrehen

Trapezgewinde,
Teilprofil, innen
mit innerer Kühlmittelzufuhr

type threading,
trapezoidal thread,
partial profile, internal
with through coolant

D min. 7.0
P = 2.0 - 3.0

... 156

ULTRAMINI

Bohrungsbearbeitung
ab Ø 0.2 mm

grooving, boring and profiling
starting at Ø 0.2 mm

Übersicht

summary

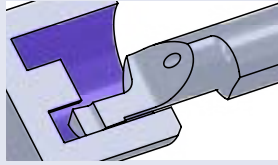
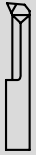

Schneideinsätze Axialstechen

inserts face grooving

Maße dimensions [mm]

Seite page

Typ 510M	Axialstechen mit Eckenradius	face grooving with corner radius	D min. 5.0 t max. 4.0	... 158
Performanceline Typ 51PM	Axialstechen mit Eckenradius und innerer Kühlmittelzufuhr	face grooving with corner radius and through coolant	D min. 5.0 t max. 4.0	... 159
Typ 610	Axialstechen	face grooving	D min. 6.0 t max. 3.5	... 160
Typ 610M	Axialstechen mit Eckenradius	face grooving with corner radius	D min. 6.0 t max. 6.0	... 161
Performanceline Typ 61PM	Axialstechen mit Eckenradius und innerer Kühlmittelzufuhr	face grooving with corner radius and through coolant	D min. 6.0 t max. 6.0	... 162
Typ 610	Axialstechen mit Vollradius	face grooving with full radius	D min. 6.0 t max. 6.0	... 163
Performanceline Typ 61P	Axialstechen mit Vollradius und innerer Kühlmittelzufuhr	face grooving with full radius and through coolant	D min. 6.0 t max. 6.0	... 164
Typ 620	Axialstechen am Zapfen vorbei	face grooving in pivots	D min. 6.0 t max. 6.0	... 165
Typ 620M	Axialstechen am Zapfen vorbei, mit Eckenradius	face grooving in pivots, with corner radius	D min. 6.0 t max. 6.0	... 166
Performanceline Typ 62PM	Axialstechen am Zapfen vorbei, mit Eckenradius und innerer Kühlmittelzufuhr	face grooving in pivots, with corner radius and through coolant	D min. 6.0 t max. 6.0	... 167
Typ 620	Axialstechen am Zapfen vorbei mit Vollradius	face grooving in pivots with full radius	D min. 6.0 t max. 6.0	... 168

↳ ...

ULTRAMINI

Bohrungsbearbeitung
ab \varnothing 0.2 mm

grooving, boring and profiling
starting at \varnothing 0.2 mm

Übersicht

summary

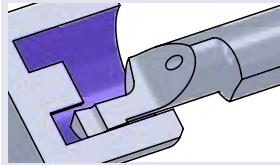

Schneideinsätze Axialstechen

inserts face grooving

Maße dimensions [mm]

Seite page



... ↴

Typ 010	Axialstechen	face grooving	D min. 6.0 t max. 3.5	... 169
Typ 010M	Axialstechen mit Eckenradius	face grooving with corner radius	D min. 8.0 t max. 6.0	... 171
Performanceline Typ P10M	Axialstechen mit Eckenradius und innerer Kühlmittelzufuhr	face grooving with corner radius and through coolant	D min. 8.0 t max. 6.0	... 173
Premiumline Typ 010P	Axialstechen mit gelasertem Spanformer und Eckenradius	face grooving with lasered chipformer and corner radius	D min. 8.0 t max. 6.0	... 175
Typ 010	Axialstechen mit Vollradius	face grooving with full radius	D min. 8.0 t max. 6.0	... 176
Performanceline Typ P10	Axialstechen mit Vollradius und innerer Kühlmittelzufuhr	face grooving with full radius and through coolant	D min. 8.0 t max. 6.0	... 177
Typ 015	Axialstechen	face grooving	D min. 8.0 t max. 30	... 178
Typ 015M	Axialstechen mit Eckenradius	face grooving with corner radius	D min. 8.0 t max. 30	... 179
Typ 012 / 016	Axialstechen mit Eckenradius und doppeltem Kühlkanal	face grooving with corner radius and double internal cooling	D min. 12.0 t max. 20	... 180
Typ 020	Axialstechen mit Eckenradius und doppeltem Kühlkanal	face grooving with corner radius and double internal cooling	D min. 20.0 t max. 40	... 181
Typ 012 / 020	Axialstechen mit Vollradius und doppeltem Kühlkanal	face grooving with full radius and double internal cooling	D min. 12 / 20 t max. 20 / 30	... 182
Typ 520	Fasen	chamfering	D min. 1.0 t max. 4.0	... 183
Performanceline Typ 52P	Fasen mit innerer Kühlmittelzufuhr	chamfering with through coolant	D min. 1.0 t max. 4.0	... 184

ULTRAMINI

Bohrungsbearbeitung
ab Ø 0.2 mm

grooving, boring and profiling
starting at Ø 0.2 mm

Übersicht

summary

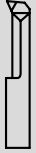

Sets Ultramini

Halter und Schneiden (Rechte Ausführung)

sets Ultramini

toolholder and inserts (righthand version)

Maße
dimensions
[mm]

Seite
page

SET.1	<ul style="list-style-type: none"> • Ausdrehen und Kopieren • Ausdrehen und Fasen • Stechdrehen 	<ul style="list-style-type: none"> • boring and profiling • boring and chamfering • grooving 	... 186
SET.2	<ul style="list-style-type: none"> • Stechdrehen 	<ul style="list-style-type: none"> • grooving 	... 186
SET.3	<ul style="list-style-type: none"> • Ausdrehen und Kopieren 	<ul style="list-style-type: none"> • boring and profiling 	... 187
SET.6R	<ul style="list-style-type: none"> • Axialstechen 	<ul style="list-style-type: none"> • face grooving 	... 187
SET-RDT-4	<ul style="list-style-type: none"> • Bohren und Ausdrehen • D min. 3,7 	<ul style="list-style-type: none"> • drilling and boring • D min. 3,7 	... 188
SET-RDT-5	<ul style="list-style-type: none"> • Bohren und Ausdrehen • D min. 4,7 	<ul style="list-style-type: none"> • drilling and boring • D min. 4,7 	... 188
SET-RDT-6	<ul style="list-style-type: none"> • Bohren und Ausdrehen • D min. 5,7 	<ul style="list-style-type: none"> • drilling and boring • D min. 5,7 	... 189
SET-RDT-7	<ul style="list-style-type: none"> • Bohren und Ausdrehen • D min. 6,7 	<ul style="list-style-type: none"> • drilling and boring • D min. 6,7 	... 189



Sets Ultramini

Halter und Schneiden (Linke Ausführung)

sets Ultramini

toolholder and inserts (lefthand version)

Maße
dimensions
[mm]

Seite
page

SET.2/LINKS	<ul style="list-style-type: none"> • Stechdrehen 	<ul style="list-style-type: none"> • grooving 	... 190
--------------------	---	--	---------



Sets Ultramini

Reduzierhülsen für Halter

sets Ultramini

reduction bushes for toolholder

Maße
dimensions
[mm]

Seite
page

SET-RBD12	<ul style="list-style-type: none"> • Reduzierhülsen für Halter: - Typ UMHB - Typ UM.RBD12.00 	<ul style="list-style-type: none"> • reduction bushes for toolholder: - type UMHB - type UM.RBD12.00 	... 190
------------------	---	---	---------

ULTRAMINI

Bohrungsbearbeitung
ab \varnothing 0.2 mm

grooving, boring and profiling
starting at \varnothing 0.2 mm

Übersicht

summary

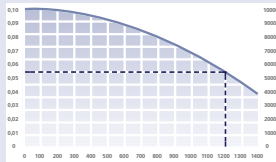

Technische Hinweise

Technical instructions

Seite
page

Grundsätzliche Informationen
zum Werkzeugprogramm Ultramini

Basic informations about
the tool program Ultramini

... 192

Allgemeine Informationen zum
Gewindeschneiden

General informations about threading

... 193

Informationen zur Kühlung
von Typ Hardline und Typ 050.../CBN

cooling informations about type
Hardline and type 050.../CBN

... 195

Hartmetallsorten und Beschichtungen

carbide grades and coatings

... 196

Allgemeine Informationen über
Schnitttiefe und Vorschub für
Typ DT

General instructions about
cutting depth and feed
of type DT

... 199

Schnittdatenempfehlung

speed and feed recommendation

... 200

ULTRAMINI

Bohrungsbearbeitung
ab \varnothing 0.2 mm

grooving, boring and profiling
starting at \varnothing 0.2 mm

Allgemeine Beschreibung

general instruction

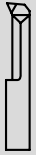

Ultramini:

Das überlegene System in der Mini-Bohrungsbearbeitung mit über 2500 Schneideinsätzen!

Ultramini:

The superior system in the world of miniature machining with over 2500 different inserts!

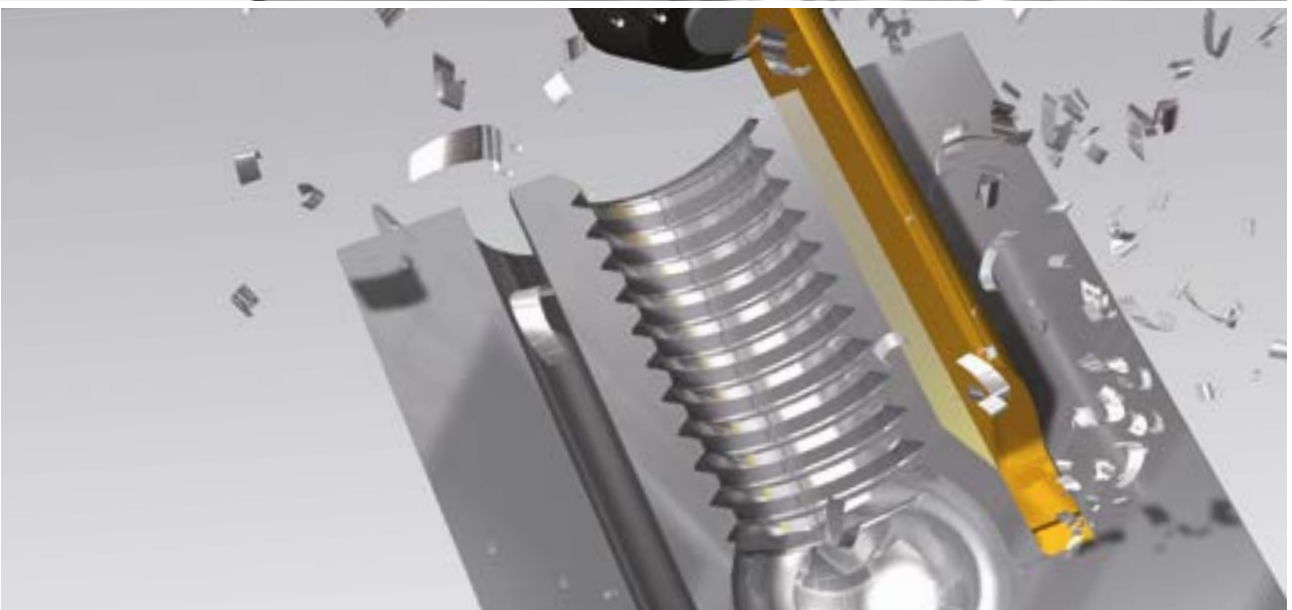

ULTRAMINI

Bohrungsbearbeitung
ab \varnothing 0.2 mm

grooving, boring and profiling
starting at \varnothing 0.2 mm

Impressionen

impressions



ULTRAMINI

Bohrungsbearbeitung
ab $\varnothing 0.2$ mm

grooving, boring and profiling
starting at $\varnothing 0.2$ mm

Allgemeine Beschreibung

Superfinish, Mediline, Xtraline, Hardline,
Premiumline und Performanceline

general instruction
Superfinish, Mediline, Xtraline, Hardline,
Premiumline und Performanceline



Typ F050 Superfinish

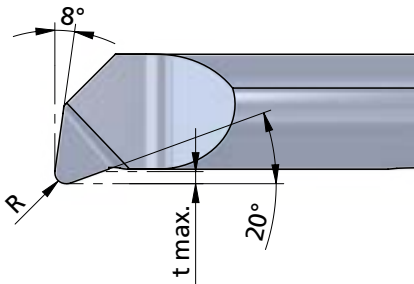

- Großer Eckenradius für hohe Oberflächenqualität
- Sonderhartmetall für einen stabilen und schwingungsarmen Aufbau
- Optimierte Beschichtung für eine geringe Rauhtiefe in der Bohrung
- Bei Einsatz im PT-Halter verbesserte Kühlung
- Big corner radius for high surface quality
- Premium carbide for a strong and low-vibration construction
- Optimized coating causes extremely low surface roughness in the bore
- Better cooling by using PT- toolholder

Typ M050 Mediline

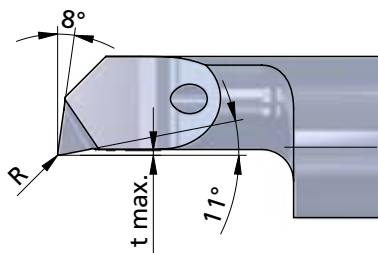

- Modifizierte Geometrie speziell für Materialien aus der Medizintechnik
- Innere Kühlmittelzufuhr
- Reduziertes t max. für höhere Stabilität
- Ausgezeichnete Oberflächenqualität der Schneide
- Eckenradius verspricht längere Standzeit und bessere Oberflächenqualität
- Modified geometry specifically designed for materials of medical technology
- Internal coolant supply
- Reduced t max. for higher stability
- Superior grinding surface quality
- Corner radius provides longer tool life and better surface finishes

Typ X050 Xtraline

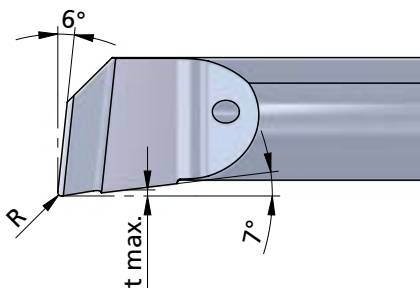

- Modifizierte Geometrie speziell für Nickel- und Chromlegierungen
- Innere Kühlmittelzufuhr
- Position der Kühlmittelzufuhr optimiert für beste Stabilität
- Reduziertes t max. für höhere Stabilität
- Variabler Eckenradius verspricht längere Standzeit und bessere Oberflächenqualität
- Spantreppe reduziert Schneidkräfte und ermöglicht höhere Schnittgeschwindigkeiten
- Modified geometrie specifically designed for Nickel and Chrome based alloys
- Internal coolant supply
- Coolant hole location optimized for greatest tool rigidity
- Reduced t max. for higher stability
- Various corner radius provides for longer tool life and better surface finishes
- Chip breaker reduces cutting forces and provides for higher cutting feed

ULTRAMINI

Bohrungsbearbeitung
ab $\varnothing 0.2$ mm

grooving, boring and profiling
starting at $\varnothing 0.2$ mm

Allgemeine Beschreibung

Superfinish, Mediline, Xtraline, Hardline,
Premiumline und Performanceline

general instruction
Superfinish, Mediline, Xtraline, Hardline,
Premiumline and Performanceline

Typ 050

Hardline

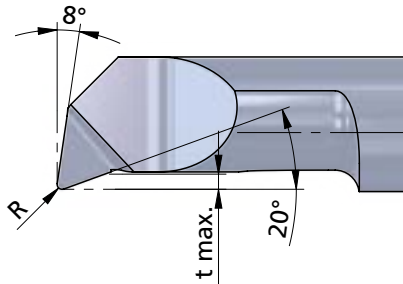

- Wirtschaftlicher als CBN
- Bis 66 HRC einsetzbar
- Optimal für dünnwandige Materialien
- Universell einsetzbar
- Scharfe Schneide
- Nur mit Kühlung arbeiten
- More economical than CBN
- Machine up to HRC 66
- Perfect for thin wall materials
- Very universal
- Sharp insert
- Don't use without cooling

Typ 010P

Premiumline

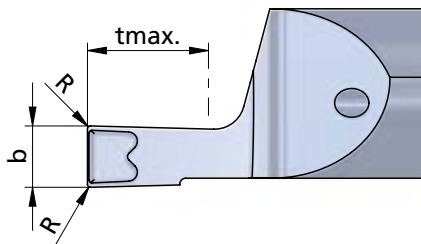

- 4-5 mal größerer Vorschub beim Stechen ins Volle (materialabhängig)
- 1-2 mal größere Schnittgeschwindigkeit V_c beim Stechen ins Volle (materialabhängig)
- Bei gleichen und höheren Schnittwerten höhere Oberflächengüte
- Ruhiger Lauf während Bearbeitung
- Gute Standzeit
- 4-5 times higher feed rate when grooving in solid material (depending on material)
- 1-2 times higher cutting speed when grooving in solid material (depending on material)
- Higher surface quality with the same or higher cutting values
- Smooth running while machining
- Long tool life

Typ P50

Performanceline

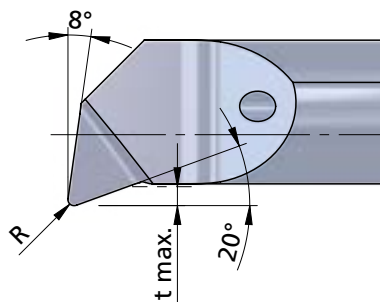

- Verwendet die vorhandenen Vorteile der bestehenden Ultraminischneide mit Verbesserung im Detail
- Innere Kühlmittelzufuhr
- Verbesserter Spantransport
- Optimierte Beschichtung
- Uses the existing advantages of the existing Ultramini cutting edge with improvement in detail
- Internal coolant supply
- Improved chip transport
- Optimized coating



ULTRAMINI

Bohrungsbearbeitung
ab Ø 0.2 mm

grooving, boring and profiling
starting at Ø 0.2 mm

Typ 645

Klemmhalter

toolholder

Ø 12 - 28 mm
für Schneideinsatz mit
D min. 0.2 - 5.0 mm

Ø 12 - 28 mm
for insert with
D min. 0.2 - 5.0 mm

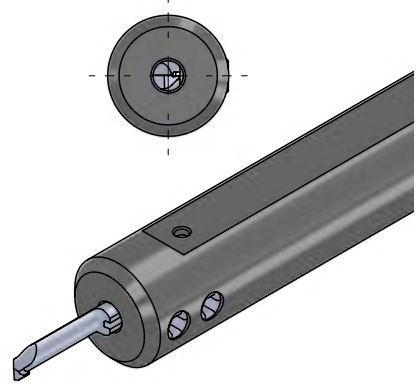
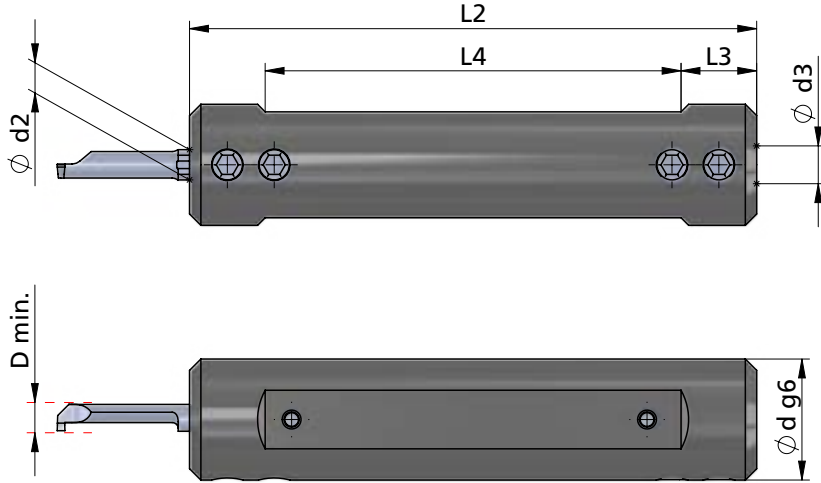

Beispielzeichnung
exemplary aication

Klemmhalter für rechte und linke
Schneideinsätze einsetzbar

toolholder for right and left
inserts usable



Abmessungen in mm

dimensions in mm

Bestellnummer part number	Abmessungen in mm			dimensions in mm			Anzugs- drehmoment torque	Beispielzeichnung exemplary aication		
	Ø d g6	Ø d (inch)	L2	L3	L4	Spannschraube screw		Schraubenschlüssel wrench	Ø d2 Ø d h6 Schneideinsatz insert	Ø d3 Ø d h6 Schneideinsatz insert
645.0012-D	12		75	10	55	A.GST003	111.645	1.2 Nm	4	5
645.0016-D	16		75	10	55	A.GST004	111.645	1.2 Nm	4	5
645.0018-D	18		90	10	70	A.GST004	111.645	1.2 Nm	4	5
645.001905-D	19.05	3/4"	90	10	70	A.GST004	111.645	1.2 Nm	4	5
645.0020-D	20		90	10	70	A.GST005	111.645	1.2 Nm	4	5
645.0022-D	22		90	10	70	A.GST005	111.645	1.2 Nm	4	5
645.0025-D	25		95	10	75	A.GST005	111.645	1.2 Nm	4	5
645.00254-D	25.4	1"	95	10	75	A.GST005	111.645	1.2 Nm	4	5
645.0028-D	28		95	10	75	A.GST005	111.645	1.2 Nm	4	5

ULTRAMINI

Bohrungsbearbeitung
ab Ø 0.2 mm

grooving, boring and profiling
starting at Ø 0.2 mm

Typ 645.PT

Klemmhalter,
Premiumline mit
verbesserter Kühlung

toolholder,
Premiumline with
improved cooling

Ø 12 - 28 mm
für Schneideinsatz mit
D min. 0.2 - 5.0 mm

Ø 12 - 28 mm
for insert with
D min. 0.2 - 5.0 mm

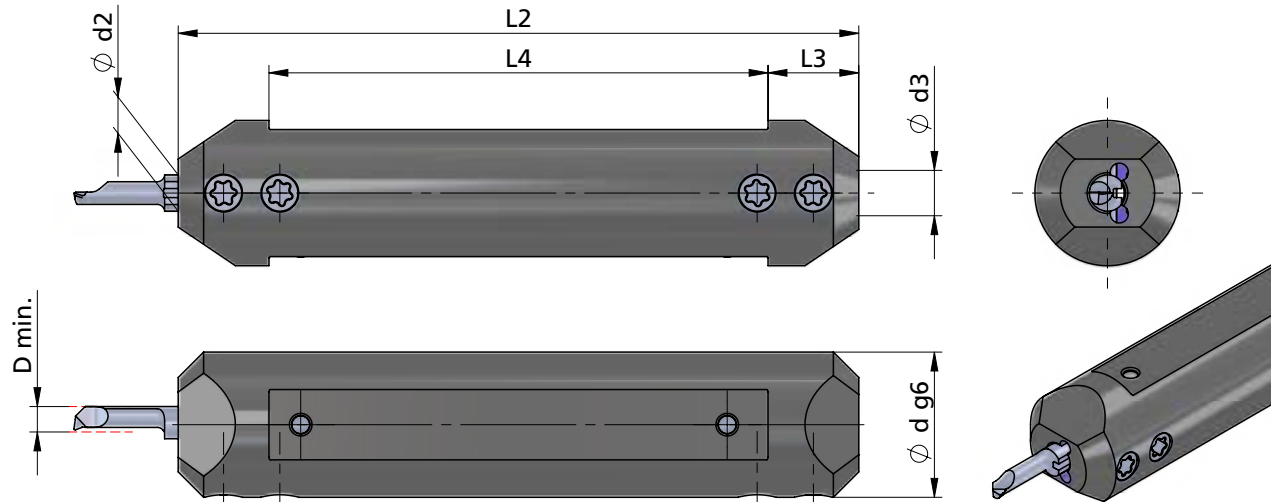

Beispielzeichnung
exemplary application

Klemmhalter für rechte und linke
Schneideinsätze einsetzbar

toolholder for right and left
inserts usable



Abmessungen in mm

dimensions in mm

Bestellnummer part number	Abmessungen in mm			dimensions in mm			Spannschraube screw	Schraubenschlüssel wrench	Anzugs- drehmoment torque	INTERNAL COOLANT SUPPLY KÜHLMITTELZUFÜHRUNG	
	Ø d g6	Ø d (inch)	L2	L3	L4	Ø d2 ≤				Ø d h6 Schneideinsatz insert	Ø d3 ≤
645.PT12-D	12		75	10	55	A.GST010	T10F	1.2 Nm	4	5	
645.PT127-D	12.7	1/2"	75	10	55	A.GST010	T10F	1.2 Nm	4	5	
645.PT1587-D	15.87	5/8"	75	10	55	A.GST011	T10F	1.2 Nm	4	5	
645.PT16-D	16		75	10	55	A.GST011	T10F	1.2 Nm	4	5	
645.PT18-D	18		90	10	70	A.GST011	T10F	1.2 Nm	4	5	
645.PT1905-D	19.05	3/4"	90	10	70	A.GST011	T10F	1.2 Nm	4	5	
645.PT20-D	20		90	10	70	A.GST012	T10F	1.2 Nm	4	5	
645.PT22-D	22		90	10	70	A.GST012	T10F	1.2 Nm	4	5	
645.PT25-D	25		95	10	75	A.GST013	T10F	1.2 Nm	4	5	
645.PT254-D	25.4	1"	95	10	75	A.GST013	T10F	1.2 Nm	4	5	
645.PT28-D	28		95	10	75	A.GST013	T10F	1.2 Nm	4	5	

Bestellbeispiel:
645.PT12-D

order-example:
645.PT12-D

ULTRAMINI

Bohrungsbearbeitung
ab $\varnothing 0.2$ mm

grooving, boring and profiling
starting at $\varnothing 0.2$ mm

Typ 676

Klemmhalter

toolholder

$\varnothing 16 - 28$ mm
für Schneideinsatz mit
D min. 6.0 - 7.0 mm

$\varnothing 16 - 28$ mm
for insert with
D min. 6.0 - 7.0 mm

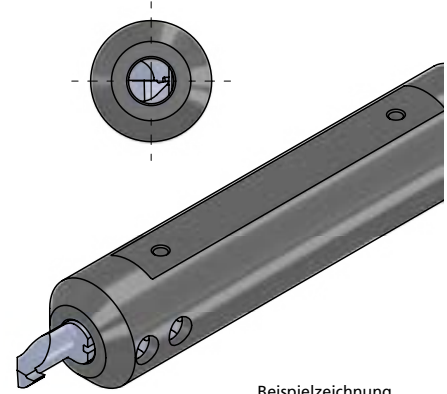
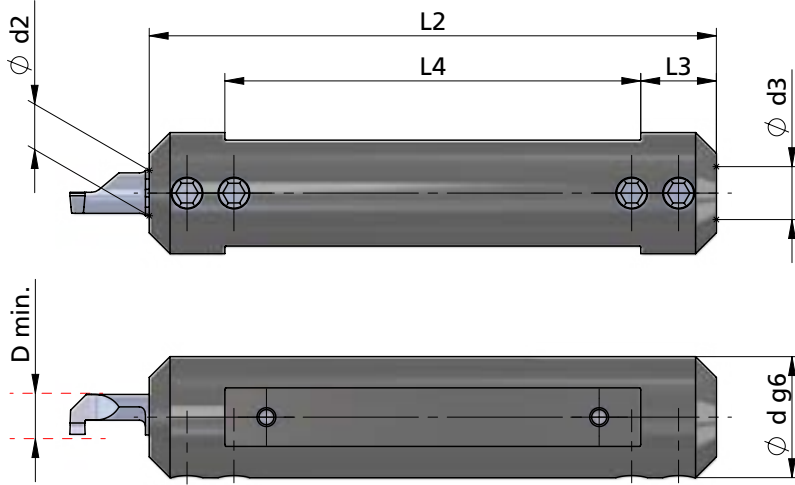

Beispielzeichnung
exemplary application

Klemmhalter für rechte und linke
Schneideinsätze einsetzbar

toolholder for right and left
inserts usable

Abmessungen in mm

dimensions in mm



Bestellnummer part number	$\varnothing d g6$	$\varnothing d$ (inch)	L2	L3	L4	Spannschraube screw	Schraubenschlüssel wrench	Anzugs- drehmoment torque	Schneideinsatz insert	
									$\varnothing d2$	$\varnothing d h6$
676.0016-D	16		75	10	55	A.GST004	111.645	1.2 Nm	6	7
676.0018-D	18		90	10	70	A.GST004	111.645	1.2 Nm	6	7
676.001905-D	19.05	3/4"	90	10	70	A.GST004	111.645	1.2 Nm	6	7
676.0020-D	20		90	10	70	A.GST005	111.645	1.2 Nm	6	7
676.0022-D	22		90	10	70	A.GST005	111.645	1.2 Nm	6	7
676.0025-D	25		95	10	75	A.GST005	111.645	1.2 Nm	6	7
676.00254-D	25.4	1"	95	10	75	A.GST005	111.645	1.2 Nm	6	7
676.0028-D	28		95	10	75	A.GST005	111.645	1.2 Nm	6	7

ULTRAMINI

Bohrungsbearbeitung
ab $\varnothing 0.2$ mm

grooving, boring and profiling
starting at $\varnothing 0.2$ mm

Typ 676.PT

Klemmhalter,
Premiumline mit
verbesserter Kühlung

toolholder,
Premiumline with
improved cooling

$\varnothing 15.87 - 28$ mm
für Schneideinsatz mit
D min. 6.0 - 7.0 mm

$\varnothing 15.87 - 28$ mm
for insert with
D min. 6.0 - 7.0 mm

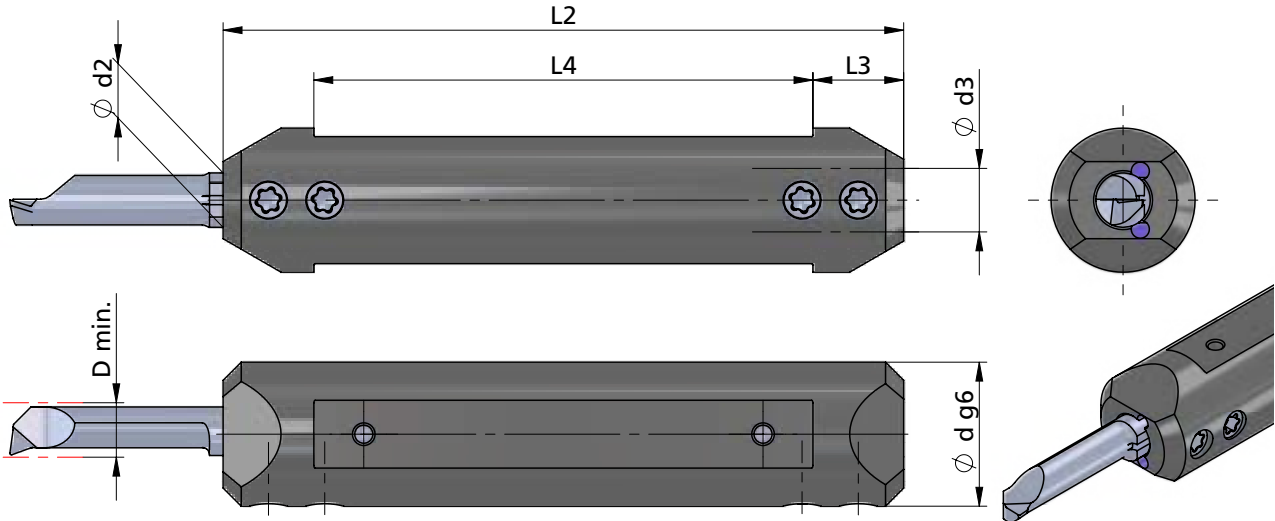

Beispielzeichnung
exemplary application

Klemmhalter für rechte und linke
Schneideinsätze einsetzbar

toolholder for right and left
inserts usable



Abmessungen in mm

dimensions in mm

Bestellnummer part number	Abmessungen in mm					Spannschraube screw	Schraubenschlüssel wrench	Anzugs- drehmoment torque	INTERNAL COOLANT SUPPLY	
	$\varnothing d g6$	$\varnothing d$ (inch)	L2	L3	L4				$\varnothing d2$	$\varnothing d h6$ Schneideinsatz insert
676.PT1587-D	15.87	5/8"	75	10	55	A.GST011	T10F	1.2 Nm	6	7
676.PT16-D	16		75	10	55	A.GST011	T10F	1.2 Nm	6	7
676.PT18-D	18		90	10	70	A.GST011	T10F	1.2 Nm	6	7
676.PT1905-D	19.05	3/4"	90	10	70	A.GST011	T10F	1.2 Nm	6	7
676.PT20-D	20		90	10	70	A.GST012	T10F	1.2 Nm	6	7
676.PT22-D	22		90	10	70	A.GST012	T10F	1.2 Nm	6	7
676.PT25-D	25		95	10	75	A.GST013	T10F	1.2 Nm	6	7
676.PT254-D	25.4	1"	95	10	75	A.GST013	T10F	1.2 Nm	6	7
676.PT28-D	28		95	10	75	A.GST013	T10F	1.2 Nm	6	7

Bestellbeispiel:
676.PT16-D

order-example:
676.PT16-D

ULTRAMINI

Bohrungsbearbeitung
ab Ø 0.2 mm

grooving, boring and profiling
starting at Ø 0.2 mm

Typ 687 / 681

Klemmhalter

toolholder

Ø 16 - 25.4 mm
für Schneideinsatz mit D min. 6.8 - 7.8 mm
und D min. 7.8 - 10.5 mm

Ø 16 - 25.4 mm
for insert with D min. 6.8 - 7.8 mm
and D min. 7.8 - 10.5 mm

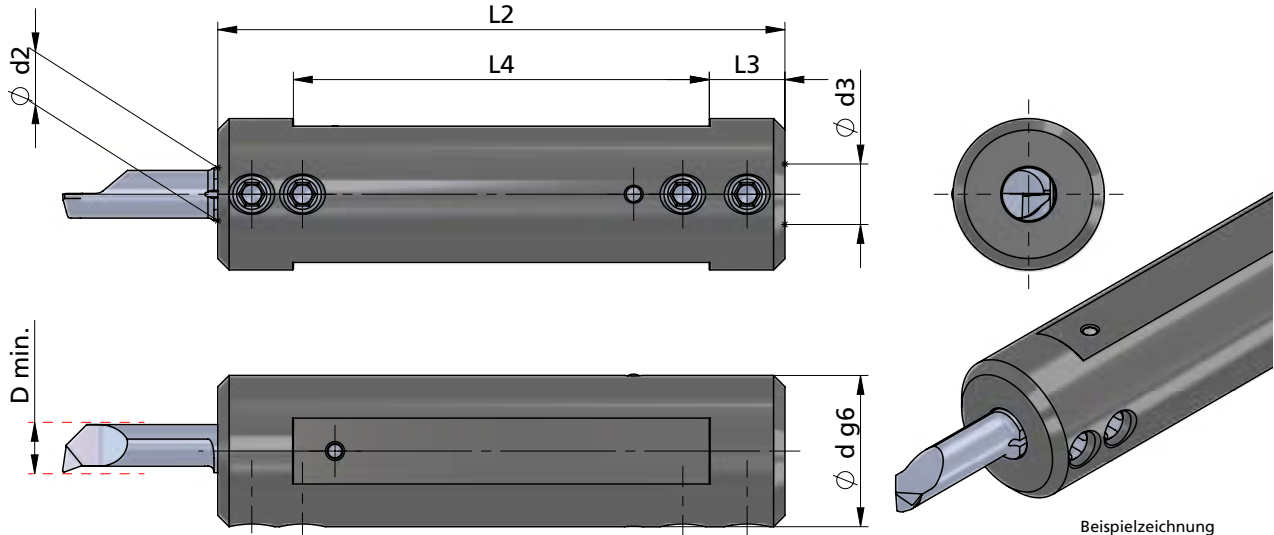

Beispielzeichnung
exemplary application

Klemmhalter für rechte und linke
Schneideinsätze einsetzbar

toolholder for right and left
inserts usable

Abmessungen in mm

dimensions in mm



Bestellnummer part number	Abmessungen in mm			dimensions in mm			Spannschraube screw	Schraubenschlüssel wrench	Anzugs- drehmoment torque	INTERNAL COOLANT SUPPLY INTERNE KÜHLMITTELZUFÜHRUNG	
	Ø d g6	Ø d (inch)	L2	L3	L4	Ø d2 ≤				Ø d h6 Schneideinsatz insert	Ø d3 ≤
687.0016-D	16		75	10	55	A.GST001	111.INB3	2.5 Nm	7	8	
687.0020-D	20		90	10	70	A.GST001	111.INB3	2.5 Nm	7	8	
687.0025-D	25		95	10	75	A.GST001	111.INB3	2.5 Nm	7	8	
687.00254-D	25.4	1"	95	10	75	A.GST001	111.INB3	2.5 Nm	7	8	
681.0020-D	20		100	10	80	A.GST003	111.645	1.2 Nm	8	10	

ULTRAMINI

Bohrungsbearbeitung
ab $\varnothing 0.2$ mm

grooving, boring and profiling
starting at $\varnothing 0.2$ mm

Typ 687.PT

Klemmhalter,
Premiumline mit
verbesserter Kühlung

toolholder,
Premiumline with
improved cooling

$\varnothing 16 - 20$ mm
für Schneideinsatz mit
D min. 6.8 - 7.8 mm

$\varnothing 16 - 20$ mm
for insert with
D min. 6.8 - 7.8 mm

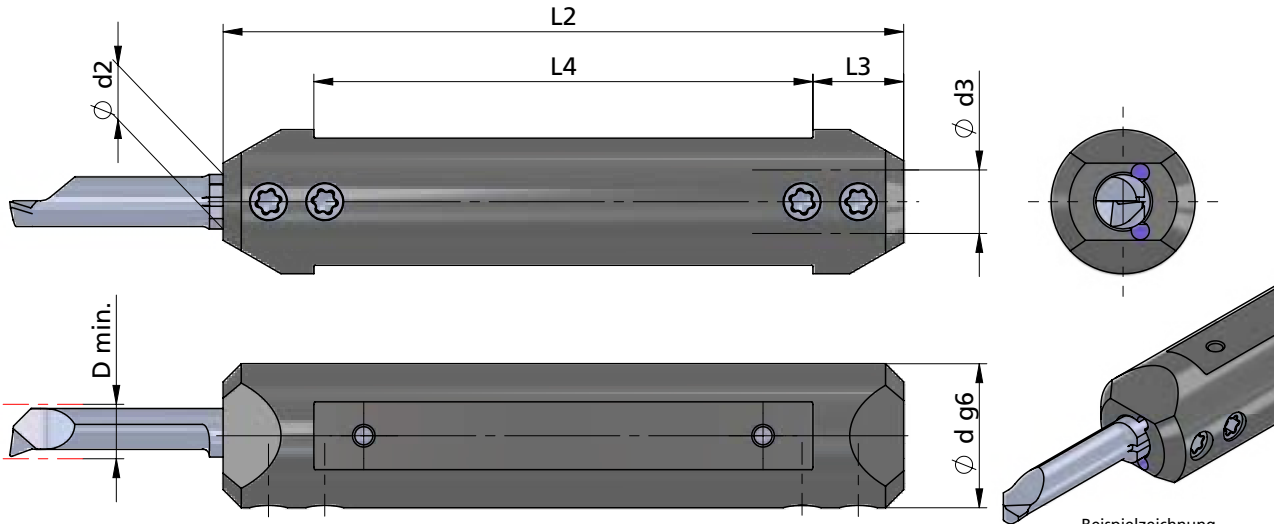

Beispielzeichnung
exemplary application

Klemmhalter für rechte und linke
Schneideinsätze einsetzbar

toolholder for right and left
inserts usable



Abmessungen in mm

dimensions in mm

Bestellnummer part number	Abmessungen in mm				Spannschraube screw	Schraubenschlüssel wrench	Anzugs- drehmoment torque	INTERNAL COOLANT SUPPLY	
	$\varnothing d g6$	L2	L3	L4				$\varnothing d2$	$\varnothing d h6$ Schneideinsatz insert
687.PT16-D	16	75	10	55	A.GST010	T10F	1.2 Nm	7	8
687.PT20-D	20	90	10	70	A.GST011	T10F	1.2 Nm	7	8

ULTRAMINI

Bohrungsbearbeitung
ab Ø 0.2 mm

grooving, boring and profiling
starting at Ø 0.2 mm

Typ 640 / 650 / 660 / 670 / 680

Klemmhalter

Ø 12 / 12.7 mm
für Schneideinsatz mit
D min. 0.2 - 7.8 mm

toolholder

Ø 12 / 12.7 mm
for insert with
D min. 0.2 - 7.8 mm

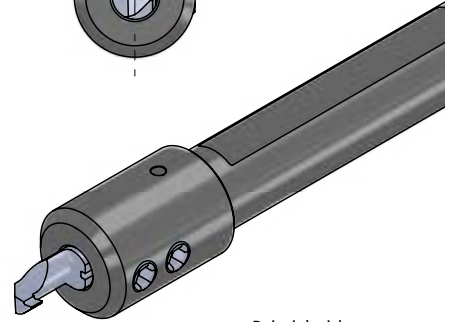
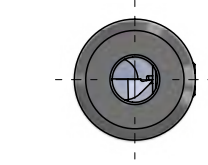
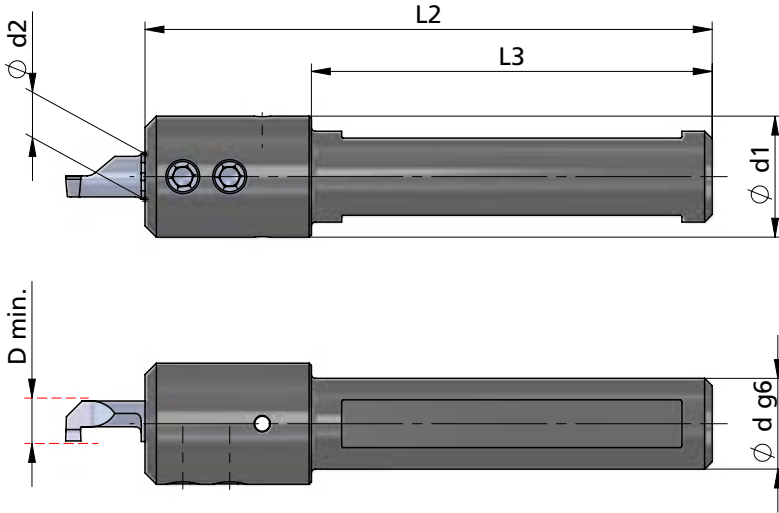

Beispielzeichnung
exemplary application

Klemmhalter für rechte und linke
Schneideinsätze einsetzbar

toolholder for right and left
inserts usable

Abmessungen in mm

dimensions in mm



Bestellnummer part number	Ø d g6		L2	Ø d1		Spannschraube screw	Schraubenschlüssel wrench	Anzugs- drehmoment torque	Ø d2 Ø d h6 Schneideinsatz insert
	Ø d (inch)								
640.0012	12		75	16	53	A.GST008	111.645	1.2 Nm	4
650.0012	12		75	16	53	A.GST008	111.645	1.2 Nm	5
660.0012	12		75	16	53	A.GST008	111.645	1.2 Nm	6
660.0127	12.7	1/2"	75	16	53	A.GST008	111.645	1.2 Nm	6
670.0012	12		75	16	53	A.GST008	111.645	1.2 Nm	7
670.0127	12.7	1/2"	75	16	53	A.GST008	111.645	1.2 Nm	7
680.0012	12		75	16	53	A.GST008	111.645	1.2 Nm	8
680.0127	12.7	1/2"	75	16	53	A.GST008	111.645	1.2 Nm	8

ULTRAMINI

Bohrungsbearbeitung
ab $\varnothing 0.2$ mm

grooving, boring and profiling
starting at $\varnothing 0.2$ mm

Typ 640.DT / 650.DT

Klemmhalter

toolholder

$\varnothing 12 - 25.4$ mm
für Schneideinsatz mit
D min. 0.2 - 5.0 mm

$\varnothing 12 - 25.4$ mm
for insert with
D min. 0.2 - 5.0 mm

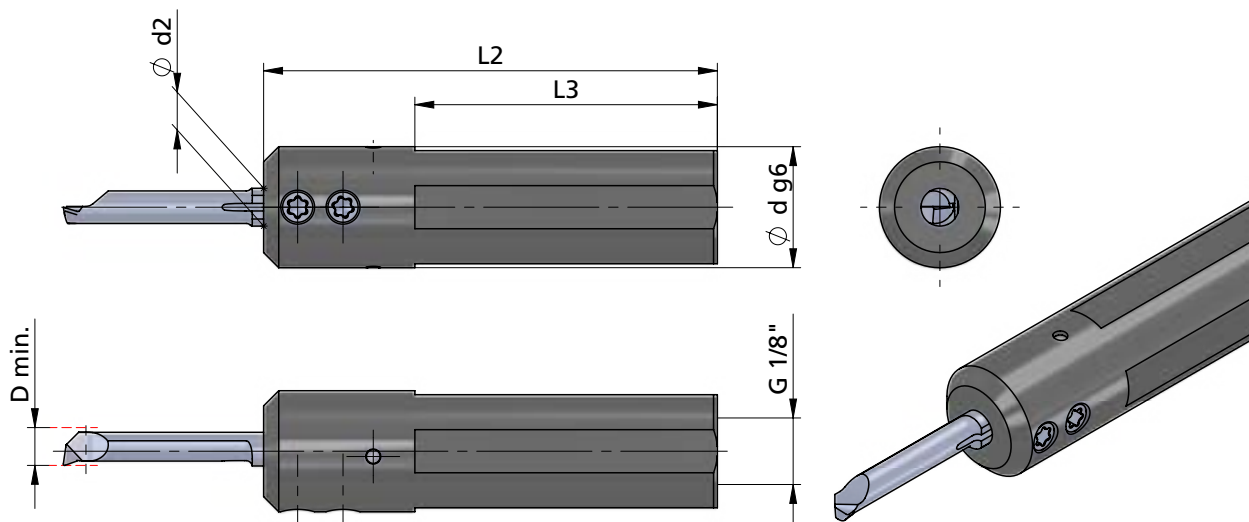

Beispielzeichnung
exemplary application

Klemmhalter für rechte und linke
Schneideinsätze einsetzbar

toolholder for right and left
inserts usable

Abmessungen in mm

dimensions in mm



Bestellnummer part number	$\varnothing d g6$	$\varnothing d$ (inch)	L2	L3	Spannschraube screw	Schraubenschlüssel wrench	Anzugs- drehmoment torque	$\varnothing d2$ $\varnothing d h6$ Schneideinsatz insert
640.DT12	12		60	40	A.GST010	T10F	1.2 Nm	4
640.DT16	16		60	40	A.GST011	T10F	1.2 Nm	4
640.DT1905	19.05	3/4"	60	40	A.GST011	T10F	1.2 Nm	4
640.DT20	20		60	40	A.GST012	T10F	1.2 Nm	4
640.DT22	22		60	40	A.GST012	T10F	1.2 Nm	4
640.DT25	25		60	40	A.GST013	T10F	1.2 Nm	4
640.DT254	25.4	1"	60	40	A.GST013	T10F	1.2 Nm	4
650.DT12	12		60	40	A.GST010	T10F	1.2 Nm	5
650.DT16	16		60	40	A.GST011	T10F	1.2 Nm	5
650.DT1905	19.05	3/4"	60	40	A.GST011	T10F	1.2 Nm	5
650.DT20	20		60	40	A.GST012	T10F	1.2 Nm	5
650.DT22	22		60	40	A.GST012	T10F	1.2 Nm	5
650.DT25	25		60	40	A.GST013	T10F	1.2 Nm	5
650.DT254	25.4	1"	60	40	A.GST013	T10F	1.2 Nm	5

Bestellbeispiel:
640.DT12

order-example:
640.DT12

ULTRAMINI

Bohrungsbearbeitung
ab Ø 0.2 mm

grooving, boring and profiling
starting at Ø 0.2 mm

Typ 640P.DT / 650P.DT

Klemmhalter,
durch tiefere Werkzeugspannung
optimiert für Schneideinsatz Typ DT

toolholder,
by deeper insert clamping
optimized for insert type DT

Ø 12 - 25.4 mm
für Schneideinsatz mit
D min. 2.9 - 4.7 mm

Ø 12 - 25.4 mm
for insert with
D min. 2.9 - 4.7 mm

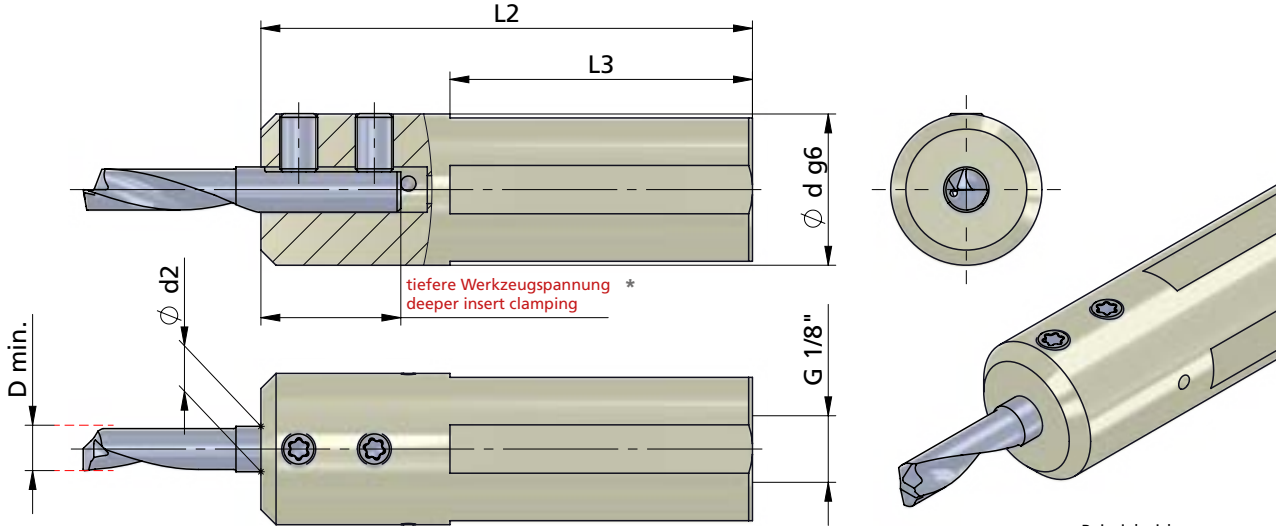

Beispielzeichnung
exemplary application

Klemmhalter für rechte und linke
Schneideinsätze einsetzbar

toolholder for right and left
inserts usable

Abmessungen in mm

dimensions in mm



Bestellnummer part number	Ø d g6	Ø d (inch)	L2	L3	Spannschraube screw	Schraubenschlüssel wrench	Anzugs- drehmoment torque	Ø d2 ≤ Ø d h6	Schneideinsatz Typ insert type
640P.DT12	12		65	40	A.GST010	T10F	1.2 Nm	4	
640P.DT16	16		65	40	A.GST011	T10F	1.2 Nm	4	
640P.DT1905	19.05	3/4"	65	40	A.GST011	T10F	1.2 Nm	4	
640P.DT20	20		65	40	A.GST012	T10F	1.2 Nm	4	R/L DT.4 ...
640P.DT22	22		65	40	A.GST012	T10F	1.2 Nm	4	
640P.DT25	25		65	40	A.GST013	T10F	1.2 Nm	4	
640P.DT254	25.4	1"	65	40	A.GST013	T10F	1.2 Nm	4	
650P.DT12	12		65	40	A.GST010	T10F	1.2 Nm	5	
650P.DT16	16		65	40	A.GST011	T10F	1.2 Nm	5	
650P.DT1905	19.05	3/4"	65	40	A.GST011	T10F	1.2 Nm	5	
650P.DT20	20		65	40	A.GST012	T10F	1.2 Nm	5	R/L DT.5 ...
650P.DT22	22		65	40	A.GST012	T10F	1.2 Nm	5	
650P.DT25	25		65	40	A.GST013	T10F	1.2 Nm	5	
650P.DT254	25.4	1"	65	40	A.GST013	T10F	1.2 Nm	5	

Achtung: nur für Schneiden Typ DT geeignet

attention: only usable for inserts type DT

* Achtung: nicht für Ultramini geeignet
attention: not suitable for Ultramini

ULTRAMINI

Bohrungsbearbeitung
ab $\varnothing 0.2 \text{ mm}$

grooving, boring and profiling
starting at $\varnothing 0.2 \text{ mm}$

Typ 660.DT / 670.DT

Klemmhalter

toolholder

$\varnothing 12 - 25.4 \text{ mm}$
für Schneideinsatz mit
D min. 6.0 - 7.0 mm

$\varnothing 12 - 25.4 \text{ mm}$
for insert with
D min. 6.0 - 7.0 mm

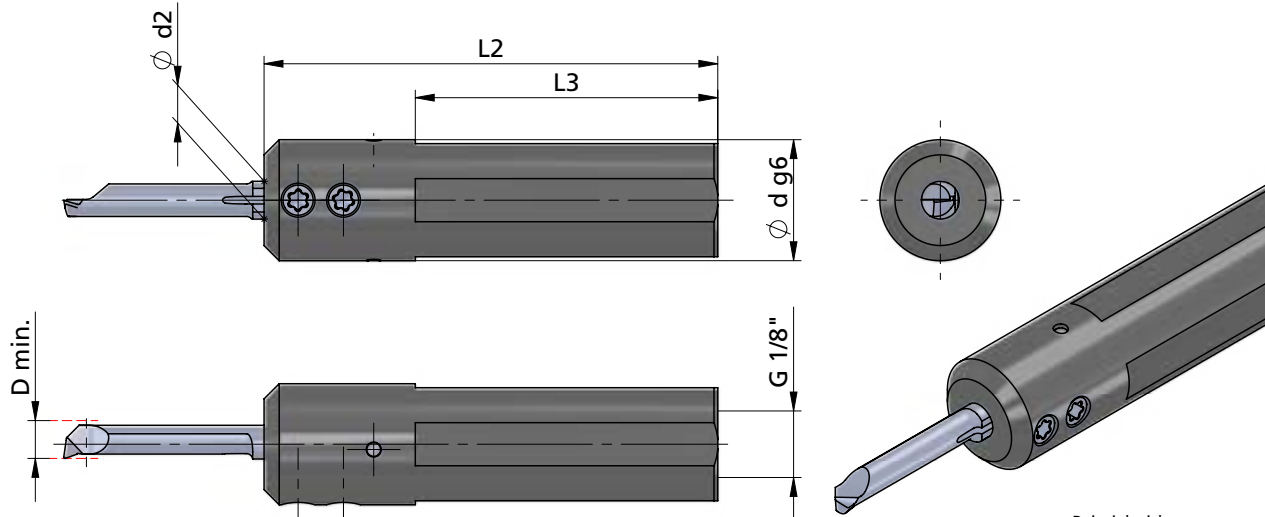

Beispielzeichnung
exemplary application

Klemmhalter für rechte und linke
Schneideinsätze einsetzbar

toolholder for right and left
inserts usable

Abmessungen in mm

dimensions in mm



Bestellnummer part number	$\varnothing d_{g6}$	$\varnothing d$ (inch)	L2	L3	Spannschraube screw	Schraubenschlüssel wrench	Anzugs- drehmoment torque	$\varnothing d_2$ $\varnothing d_{h6}$ Schneideinsatz insert
660.DT12	12		60	40	A.GST011	T10F	1.2 Nm	6
660.DT16	16		60	40	A.GST011	T10F	1.2 Nm	6
660.DT1905	19.05	3/4"	60	40	A.GST011	T10F	1.2 Nm	6
660.DT20	20		60	40	A.GST012	T10F	1.2 Nm	6
660.DT22	22		60	40	A.GST012	T10F	1.2 Nm	6
660.DT25	25		60	40	A.GST013	T10F	1.2 Nm	6
660.DT254	25.4	1"	60	40	A.GST013	T10F	1.2 Nm	6
670.DT12	12		60	40	A.GST011	T10F	1.2 Nm	7
670.DT16	16		60	40	A.GST011	T10F	1.2 Nm	7
670.DT1905	19.05	3/4"	60	40	A.GST011	T10F	1.2 Nm	7
670.DT20	20		60	40	A.GST012	T10F	1.2 Nm	7
670.DT22	22		60	40	A.GST012	T10F	1.2 Nm	7
670.DT25	25		60	40	A.GST013	T10F	1.2 Nm	7
670.DT254	25.4	1"	60	40	A.GST013	T10F	1.2 Nm	7

Bestellbeispiel:
660.DT12

order-example:
660.DT12

ULTRAMINI

Bohrungsbearbeitung
ab Ø 0.2 mm

grooving, boring and profiling
starting at Ø 0.2 mm

Typ 660P.DT / 670P.DT

Klemmhalter,
durch tiefere Werkzeugspannung
optimiert für Schneideinsatz Typ DT

toolholder,
by deeper insert clamping
optimized for insert type DT

Ø 12 - 25.4 mm
für Schneideinsatz mit
D min. 5.7 - 6.7 mm

Ø 12 - 25.4 mm
for insert with
D min. 5.7 - 6.7 mm

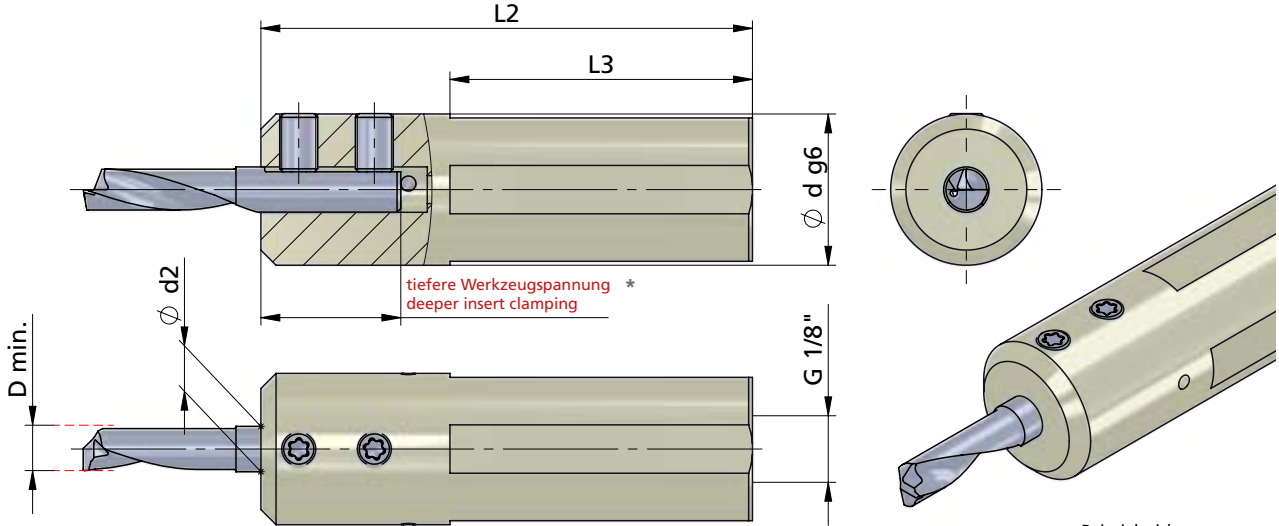

Beispielzeichnung
exemplary application

Klemmhalter für rechte und linke
Schneideinsätze einsetzbar

toolholder for right and left
inserts usable

Abmessungen in mm

dimensions in mm



Bestellnummer part number	Ø d g6	Ø d (inch)	L2	L3	Spannschraube screw	Schraubenschlüssel wrench	Anzugs- drehmoment torque	Ø d2 ≤ Ø d h6	Schneideinsatz Typ insert type
660P.DT12	12		65	40	A.GST011	T10F	1.2 Nm	6	
660P.DT16	16		65	40	A.GST011	T10F	1.2 Nm	6	
660P.DT1905	19.05	3/4"	65	40	A.GST011	T10F	1.2 Nm	6	
660P.DT20	20		65	40	A.GST012	T10F	1.2 Nm	6	R/L DT.6 ...
660P.DT22	22		65	40	A.GST012	T10F	1.2 Nm	6	
660P.DT25	25		65	40	A.GST013	T10F	1.2 Nm	6	
660P.DT254	25.4	1"	65	40	A.GST013	T10F	1.2 Nm	6	
670P.DT12	12		65	40	A.GST011	T10F	1.2 Nm	7	
670P.DT16	16		65	40	A.GST011	T10F	1.2 Nm	7	
670P.DT1905	19.05	3/4"	65	40	A.GST011	T10F	1.2 Nm	7	
670P.DT20	20		65	40	A.GST012	T10F	1.2 Nm	7	R/L DT.7 ...
670P.DT22	22		65	40	A.GST012	T10F	1.2 Nm	7	
670P.DT25	25		65	40	A.GST013	T10F	1.2 Nm	7	
670P.DT254	25.4	1"	65	40	A.GST013	T10F	1.2 Nm	7	

Achtung: nur für Schneiden Typ DT geeignet

attention: only usable for inserts type DT

* Achtung: nicht für Ultramini geeignet
attention: not suitable for Ultramini

ULTRAMINI

Bohrungsbearbeitung
ab $\varnothing 0.2$ mm

grooving, boring and profiling
starting at $\varnothing 0.2$ mm

Typ 680.DT

Klemmhalter

toolholder

$\varnothing 12 - 25.4$ mm
für Schneideinsatz mit
D min. 7.8 mm

$\varnothing 12 - 25.4$ mm
for insert with
D min. 7.8 mm

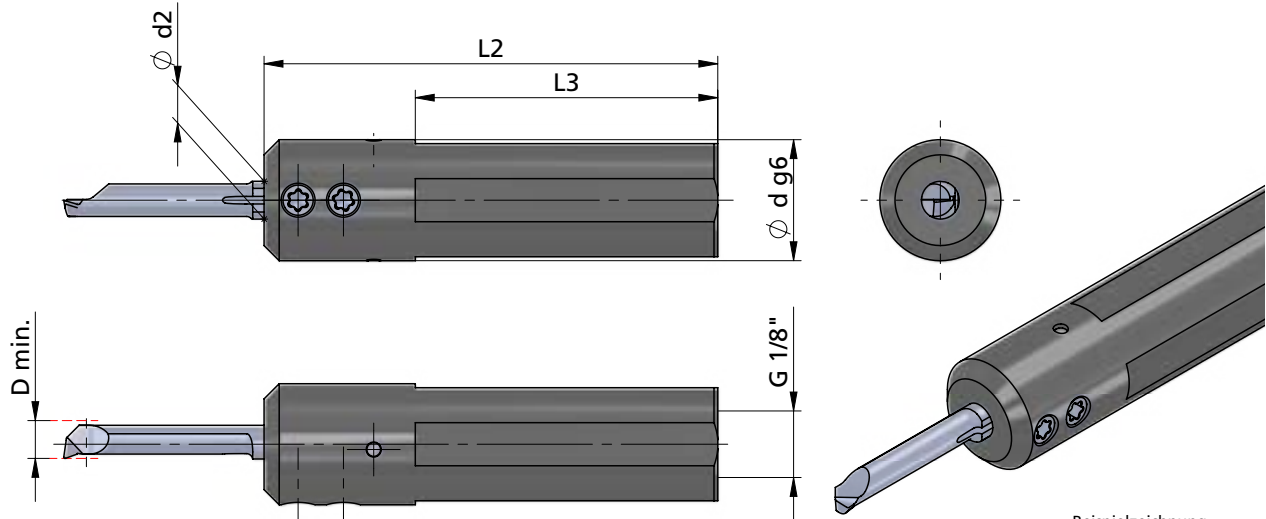

Beispielzeichnung
exemplary application

Klemmhalter für rechte und linke
Schneideinsätze einsetzbar

toolholder for right and left
inserts usable

Abmessungen in mm

dimensions in mm



Bestellnummer part number	$\varnothing d$ g6	$\varnothing d$ (inch)	L2	L3	Spannschraube screw	Schraubenschlüssel wrench	Anzugs- drehmoment torque	$\varnothing d2$ $\varnothing d$ h6 Schneideinsatz insert
680.DT12	12		60	35	A.GST011	T10F	1.2 Nm	8
680.DT16	16		60	38	A.GST010	T10F	1.2 Nm	8
680.DT1905	19.05	3/4"	60	38	A.GST011	T10F	1.2 Nm	8
680.DT20	20		60	38	A.GST011	T10F	1.2 Nm	8
680.DT22	22		60	38	A.GST011	T10F	1.2 Nm	8
680.DT25	25		60	38	A.GST012	T10F	1.2 Nm	8
680.DT254	25.4	1"	60	38	A.GST013	T10F	1.2 Nm	8

Bestellbeispiel:
680.DT12

order-example:
680.DT12

ULTRAMINI

Bohrungsbearbeitung
ab Ø 0.2 mm

grooving, boring and profiling
starting at Ø 0.2 mm

Typ 680P.DT

Klemmhalter,
durch tiefere Werkzeugspannung
optimiert für Schneideinsatz Typ DT

toolholder,
by deeper insert clamping
optimized for insert type DT

Ø 12 - 25.4 mm
für Schneideinsatz mit
D min. 7.7 mm

Ø 12 - 25.4 mm
for insert with
D min. 7.7 mm

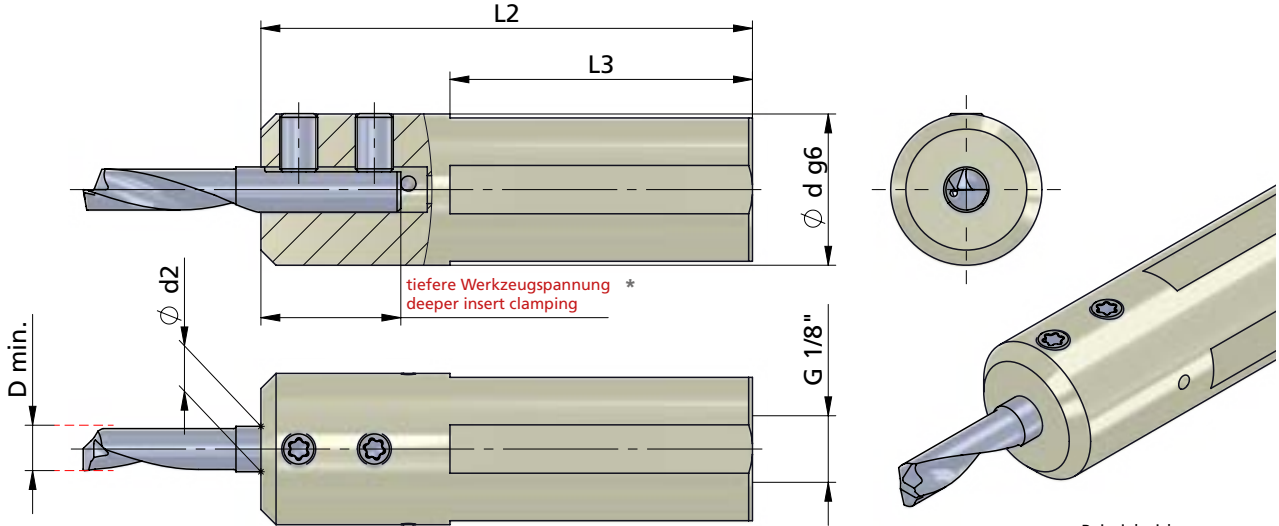

tieferer Werkzeugspannung *
deeper insert clamping

Beispielzeichnung
exemplary application

Klemmhalter für rechte und linke
Schneideinsätze einsetzbar

toolholder for right and left
inserts usable

Abmessungen in mm

dimensions in mm



Bestellnummer part number	Ø d g6	Ø d (inch)	L2	L3	Spannschraube screw	Schraubenschlüssel wrench	Anzugs- drehmoment torque	Ø d2 ≤ Ø d h6	Schneideinsatz Typ insert type
680P.DT12	12		65	35	A.GST011	T10F	1.2 Nm	8	
680P.DT16	16		65	38	A.GST010	T10F	1.2 Nm	8	
680P.DT1905	19.05	3/4"	65	38	A.GST011	T10F	1.2 Nm	8	
680P.DT20	20		65	38	A.GST011	T10F	1.2 Nm	8	R/L DT.8 ...
680P.DT22	22		65	38	A.GST011	T10F	1.2 Nm	8	
680P.DT25	25		65	38	A.GST012	T10F	1.2 Nm	8	
680P.DT25.4	25.4	1"	65	38	A.GST013	T10F	1.2 Nm	8	

Achtung: nur für Schneiden Typ DT geeignet

attention: only usable for inserts type DT

* Achtung: nicht für Ultramini geeignet
attention: not suitable for Ultramini

ULTRAMINI

Bohrungsbearbeitung
ab Ø 0.2 mm

grooving, boring and profiling
starting at Ø 0.2 mm

Typ UM.RBD12.00

Klemmhalter und Reduzierhülse
lange Ausführung,
mit Kühlmittelanschluss

toolholder and reduction bush
long version,
with coolant connection

Ø 16 - 25.4 mm
D min. ≥ 0.2

Ø 16 - 25.4 mm
D min. ≥ 0.2

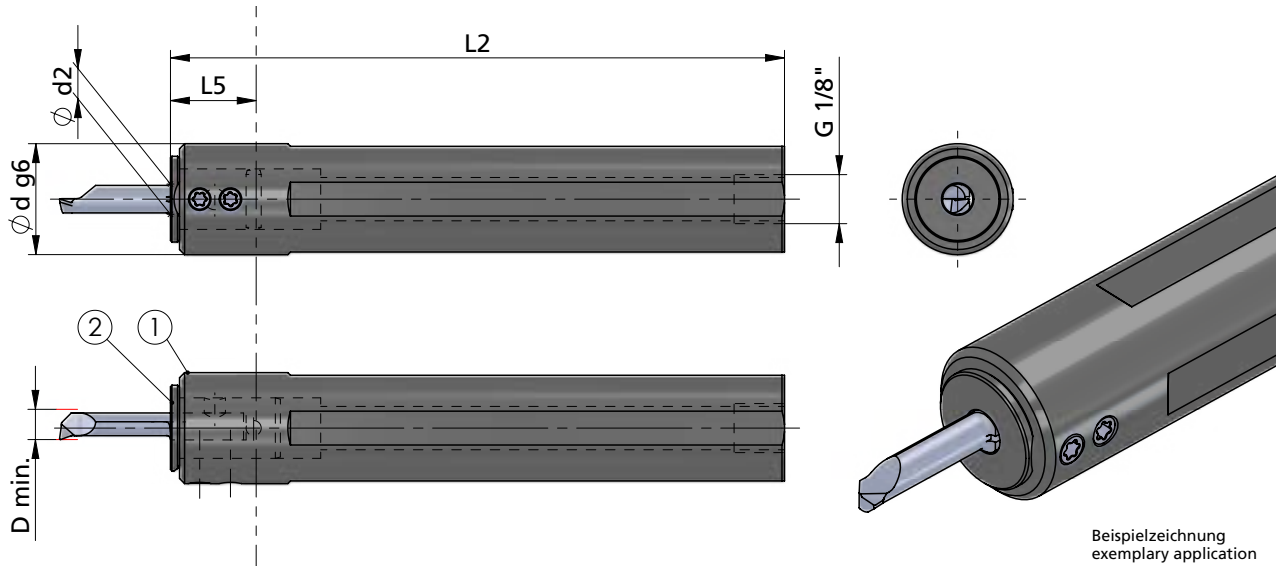

Beispielzeichnung
exemplary application

Klemmhalter für rechte und linke
Schneideinsätze einsetzbar

toolholder for right and left
inserts usable



Abmessungen in mm

dimensions in mm

Bestellnummer part number	Position	Bezeichnung description	Ø d2	Ø d g6	Ø d (inch)	L2	L5	Spannschraube screw	Schraubenschlüssel wrench	Anzugs- drehmoment torque	Schneideinsatz insert	
											Ø d2	Ø d h6
UM.RBD12.0016.120				16		121.8	32	A.GST012	T10F	1.2 Nm		
UM.RBD12.001905.120				19.05	3/4"	121.8	17	A.GST012	T10F	1.2 Nm		
UM.RBD12.0020.120				20		121.8	17	A.GST012	T10F	1.2 Nm		
UM.RBD12.0020.150		Klemmhalter Innendrehen /		20		151.8	17	A.GST012	T10F	1.2 Nm		
UM.RBD12.0022.120	1			22		121.8	17	A.GST012	T10F	1.2 Nm		
UM.RBD12.0022.150		toolholder internal turning		22		151.8	17	A.GST012	T10F	1.2 Nm		
UM.RBD12.0025.120				25		121.8	17	A.GST012	T10F	1.2 Nm		
UM.RBD12.0025.150				25		151.8	17	A.GST012	T10F	1.2 Nm		
UM.RBD12.00254.120				25.4	1"	121.8	17	A.GST012	T10F	1.2 Nm		
UMHB-RBD1204				4								4
UMHB-RBD1205				5								5
UMHB-RBD1206		Reduzierhülse /		6								6
UMHB-RBD1207	2	reduction bush		7								7
UMHB-RBD1208				8								8
UMHB-RBD1210				10								10

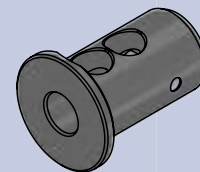

weitere Informationen:

- Kundenspezifische
Längen Anpassung ist möglich

more informations:

- customized length adjustment is
possible

Bestellbeispiel:
UM.RBD12.0016.120 + UMHB-RBD1204

order-example:
UM.RBD12.0016.120 + UMHB-RBD1204

ULTRAMINI

Bohrungsbearbeitung
ab Ø 0.2 mm

grooving, boring and profiling
starting at Ø 0.2 mm

Typ UM.RBD12.00

Klemmhalter und Reduzierhülse
kurze Ausführung,
mit Kühlmittelanschluss

toolholder and reduction bush
short version,
with coolant connection

Ø 19.05 - 25.4 mm
D min. ≥ 0.2

Ø 19.05 - 25.4 mm
D min. ≥ 0.2

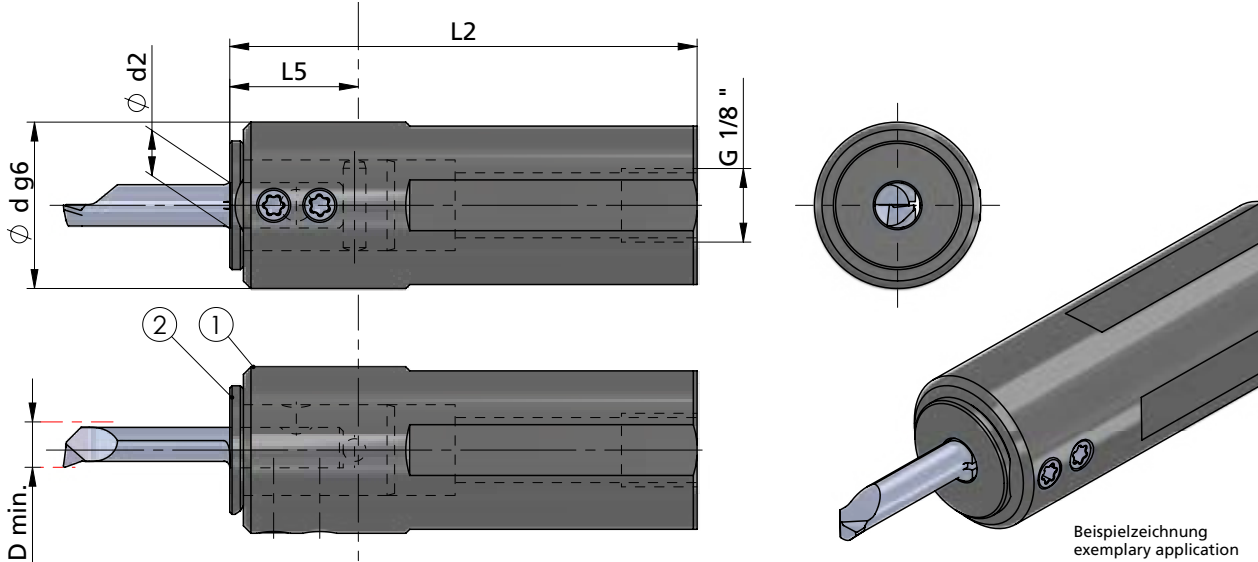

Beispielzeichnung
exemplary application

Klemmhalter für rechte und linke
Schneideinsätze einsetzbar

toolholder for right and left
inserts usable



Abmessungen in mm

dimensions in mm

Bestellnummer part number	Position	Bezeichnung description	Ø d2	Ø d g6	Ø d (inch)	L2	L5	Spannschraube screw	Schraubenschlüssel wrench	Anzugs- drehmoment torque	Ø d2 ≤ Ø d h6 Schneideinsatz insert
UM.RBD12.001905.60			19.05		3/4"	61.8	17	A.GST012	T10F	1.2 Nm	
UM.RBD12.0020.60	1	Klemmhalter Innendrehen /		20		61.8	17	A.GST012	T10F	1.2 Nm	
UM.RBD12.0022.60			22			61.8	17	A.GST012	T10F	1.2 Nm	
UM.RBD12.0025.60		toolholder internal turning	25			61.8	17	A.GST012	T10F	1.2 Nm	
UM.RBD12.00254.60			25.4		1"	61.8	17	A.GST012	T10F	1.2 Nm	
UMHB-RBD1204			4								4
UMHB-RBD1205			5								5
UMHB-RBD1206	2	Reduzierhülse / reduction bush	6								6
UMHB-RBD1207			7								7
UMHB-RBD1208			8								8
UMHB-RBD1210			10								10

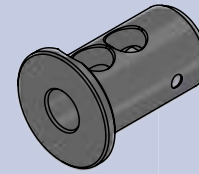

ULTRAMINI

Bohrungsbearbeitung
ab Ø 0.2 mm

grooving, boring and profiling
starting at Ø 0.2 mm

Typ UMST

Klemmhalter,
mit Hochdruckanschluss
für Langdreher

toolholder,
with high-pressure connection
for Swiss type Machines

Ø 16 - 28 mm
für Schneideinsatz mit
D min. 0.2 - 7.8 mm

Ø 16 - 28 mm
for insert with
D min. 0.2 - 7.8 mm

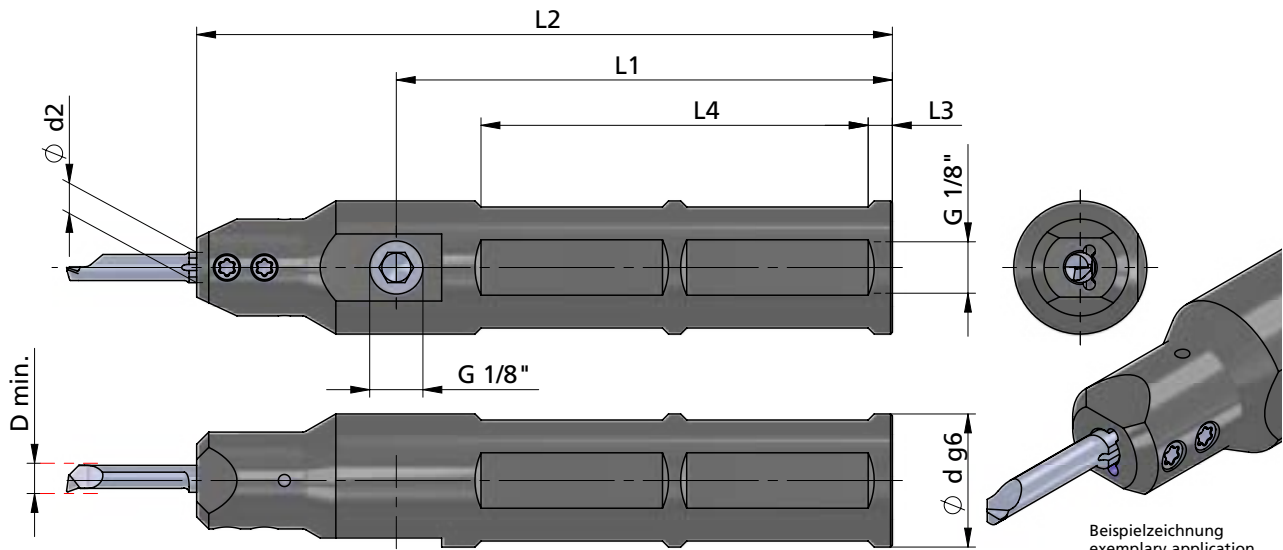

Klemmhalter für rechte und linke
Schneideinsätze einsetzbar

toolholder for right and left
inserts usable

Abmessungen in mm

dimensions in mm



Bestellnummer part number	Ø d g6	Ø d (inch)	L1	L2	L3	L4	Spannschraube screw	Schrauben- schlüssel wrench	Anzugs- drehmoment torque	Ø d2 Ø d h6 Schneideinsatz insert
UMST.0016.4	16		82	115	4	64	A.GST011	T10F	1.2 Nm	4
UMST.0016.5	16		82	115	4	64	A.GST011	T10F	1.2 Nm	5
UMST.0016.6	16		82	115	4	64	A.GST011	T10F	1.2 Nm	6
UMST.0016.7	16		82	115	4	64	A.GST011	T10F	1.2 Nm	7
UMST.0016.8	16		82	115	4	64	A.GST010	T10F	1.2 Nm	8
UMST.001905.4	19.05	3/4"	82	115	4	64	A.GST011	T10F	1.2 Nm	4
UMST.001905.5	19.05	3/4"	82	115	4	64	A.GST011	T10F	1.2 Nm	5
UMST.001905.6	19.05	3/4"	82	115	4	64	A.GST011	T10F	1.2 Nm	6
UMST.001905.7	19.05	3/4"	82	115	4	64	A.GST011	T10F	1.2 Nm	7
UMST.001905.8	19.05	3/4"	82	115	4	64	A.GST011	T10F	1.2 Nm	8
UMST.0020.4	20		82	115	4	64	A.GST011	T10F	1.2 Nm	4
UMST.0020.5	20		82	115	4	64	A.GST011	T10F	1.2 Nm	5
UMST.0020.6	20		82	115	4	64	A.GST011	T10F	1.2 Nm	6
UMST.0020.7	20		82	115	4	64	A.GST011	T10F	1.2 Nm	7
UMST.0020.8	20		82	115	4	64	A.GST011	T10F	1.2 Nm	8
↳ ...										

Bestellbeispiel:
UMST.0016.4

order-example:
UMST.0016.4

ULTRAMINI

Bohrungsbearbeitung
ab Ø 0.2 mm

grooving, boring and profiling
starting at Ø 0.2 mm

Typ UMST

Klemmhalter,
mit Hochdruckanschluss
für Langdreher

toolholder,
with high-pressure connection
for Swiss type Machines

Ø 16 - 28 mm
für Schneideinsatz mit
D min. 0.2 - 7.8 mm

Ø 16 - 28 mm
for insert with
D min. 0.2 - 7.8 mm

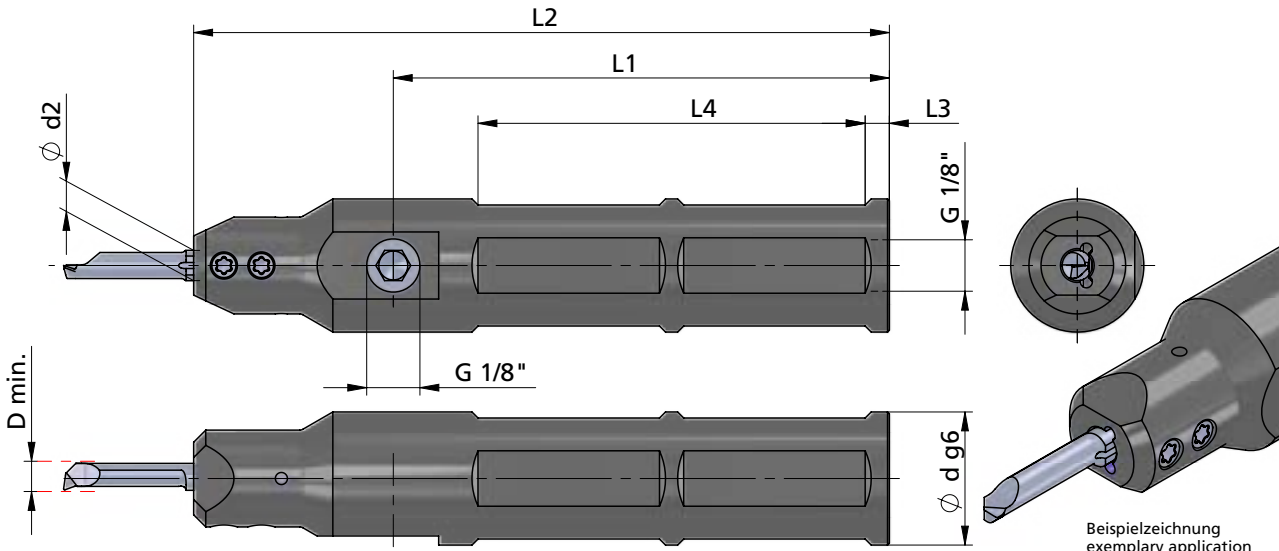

Beispielzeichnung
exemplary application

Klemmhalter für rechte und linke
Schneideinsätze einsetzbar

toolholder for right and left
inserts usable

Abmessungen in mm

dimensions in mm



Bestellnummer part number	Ø d g6	Ø d (inch)	L1	L2	L3	L4	Spannschraube screw	Schrauben- schlüssel wrench	Anzugs- drehmoment torque	Ø d2 Ø d h6 Schneideinsatz insert
UMST.0022.4	22		82	115	4	64	A.GST011	T10F	1.2 Nm	4
UMST.0022.5	22		82	115	4	64	A.GST011	T10F	1.2 Nm	5
UMST.0022.6	22		82	115	4	64	A.GST011	T10F	1.2 Nm	6
UMST.0022.7	22		82	115	4	64	A.GST011	T10F	1.2 Nm	7
UMST.0022.8	22		82	115	4	64	A.GST011	T10F	1.2 Nm	8
UMST.00254.4	25.4	1"	82	115	4	64	A.GST011	T10F	1.2 Nm	4
UMST.00254.5	25.4	1"	82	115	4	64	A.GST011	T10F	1.2 Nm	5
UMST.00254.6	25.4	1"	82	115	4	64	A.GST011	T10F	1.2 Nm	6
UMST.00254.7	25.4	1"	82	115	4	64	A.GST011	T10F	1.2 Nm	7
UMST.00254.8	25.4	1"	82	115	4	64	A.GST011	T10F	1.2 Nm	8
UMST.0028.4	28		82	115	4	64	A.GST011	T10F	1.2 Nm	4
UMST.0028.5	28		82	115	4	64	A.GST011	T10F	1.2 Nm	5
UMST.0028.6	28		82	115	4	64	A.GST011	T10F	1.2 Nm	6
UMST.0028.7	28		82	115	4	64	A.GST011	T10F	1.2 Nm	7
UMST.0028.8	28		82	115	4	64	A.GST011	T10F	1.2 Nm	8

ULTRAMINI

Bohrungsbearbeitung
ab Ø 0.2 mm

grooving, boring and profiling
starting at Ø 0.2 mm

Typ UM600H

High-Performance-Klemmhalter
mit Kühlmittelsanschluss

high-performance toolholder
with coolant connection

Ø 12 - 28 mm
für Schneideinsatz mit
D min. 0.2 - 7.0 mm

Ø 12 - 28 mm
for insert with
D min. 0.2 - 7.0 mm

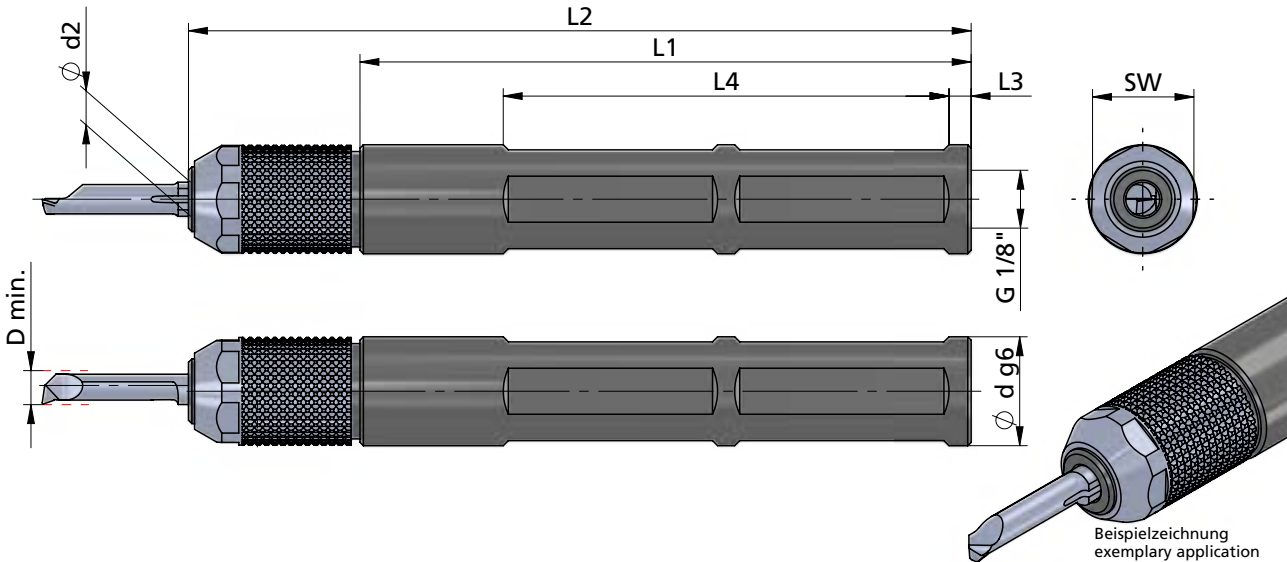

Klemmhalter für rechte und linke
Schneideinsätze einsetzbar

toolholder for right and left
inserts usable

Abmessungen in mm

dimensions in mm



Beispielzeichnung
exemplary application

Bestellnummer part number	Ø d g6	Ø d (inch)	L1	L2	L3	L4	Überwurfmutter union nut	Klemmkeil nut	Anzugs- drehmoment torque	Schneideinsatz insert	
										Ø d2	Ø d h6
UM600H.0012.4	12	90	115	4	64	UM600H.M4	UM600H.K	2 Nm	4		
UM600H.0012.5	12	90	115	4	64	UM600H.M5	UM600H.K	2 Nm	5		
UM600H.0012.6	12	90	115	4	64	UM600H.M6	UM600H.K	2 Nm	6		
UM600H.0012.7	12	90	115	4	64	UM600H.M7	UM600H.K	2 Nm	7		
UM600H.0016.4	16	90	115	4	64	UM600H.M4	UM600H.K	2 Nm	4		
UM600H.0016.5	16	90	115	4	64	UM600H.M5	UM600H.K	2 Nm	5		
UM600H.0016.6	16	90	115	4	64	UM600H.M6	UM600H.K	2 Nm	6		
UM600H.0016.7	16	90	115	4	64	UM600H.M7	UM600H.K	2 Nm	7		

Merkmale:

- Handspannung ohne zusätzlichen Schlüssel
- Wiederholgenauigkeit ± 0,005 mm (hohe Präzision)
- einfachste Bedienung
- ideal bei engen Platzverhältnissen
- Spannung mit Standardschlüssel SW15 möglich
- beim Einsatz als Rückwärtsdreher oder mit Hochdruckkühlung wird empfohlen nach handfester Spannung zusätzlich mit Schlüssel SW15 (1/4 Umdrehung) zu spannen

characteristics:

- manual clamping without additional wrench
- continuous repeatability ± 0,005 mm (high precision)
- simplest operation
- ideal where space is tight
- clamping by standard wrench SW15 is possible
- if used for back turning or with high pressure coolant: After tightening hand tight it is recommended to additionally tighten the clamp with a wrench (size 15 mm) by 1/4 turn

Bestellbeispiel:
UM600H.0012.4

order-example:
UM600H.0012.4

ULTRAMINI

Bohrungsbearbeitung
ab Ø 0.2 mm

grooving, boring and profiling
starting at Ø 0.2 mm

Typ UM600H

High-Performance-Klemmhalter
mit Kühlmittelsanschluss

high-performance toolholder
with coolant connection

Ø 12 - 28 mm
für Schneideinsatz mit
D min. 0.2 - 7.0 mm

Ø 12 - 28 mm
for insert with
D min. 0.2 - 7.0 mm

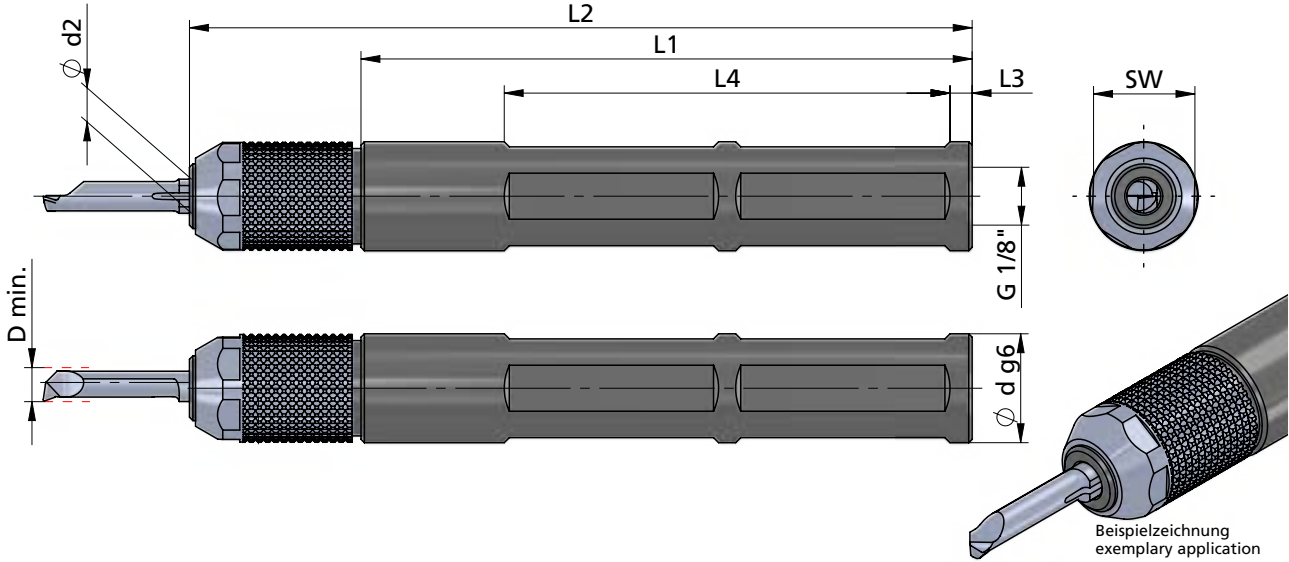

Klemmhalter für rechte und linke
Schneideinsätze einsetzbar

toolholder for right and left
inserts usable

Abmessungen in mm

dimensions in mm



Bestellnummer part number	Ø d g6	Ø d (inch)	Abmessungen in mm				Überwurfmutter union nut	Klemmkeil nut	Anzugs- drehmoment torque	Ø d2 Ø d h6 Schneideinsatz insert
			L1	L2	L3	L4				
...										
UM600H.001905.4	19.05	3/4"	90	115	4	64	UM600H.M4	UM600H.K	2 Nm	4
UM600H.001905.5	19.05	3/4"	90	115	4	64	UM600H.M5	UM600H.K	2 Nm	5
UM600H.001905.6	19.05	3/4"	90	115	4	64	UM600H.M6	UM600H.K	2 Nm	6
UM600H.001905.7	19.05	3/4"	90	115	4	64	UM600H.M7	UM600H.K	2 Nm	7
UM600H.0020.4	20		90	115	4	64	UM600H.M4	UM600H.K	2 Nm	4
UM600H.0020.5	20		90	115	4	64	UM600H.M5	UM600H.K	2 Nm	5
UM600H.0020.6	20		90	115	4	64	UM600H.M6	UM600H.K	2 Nm	6
UM600H.0020.7	20		90	115	4	64	UM600H.M7	UM600H.K	2 Nm	7
UM600H.0022.4	22		90	115	4	64	UM600H.M4	UM600H.K	2 Nm	4
UM600H.0022.5	22		90	115	4	64	UM600H.M5	UM600H.K	2 Nm	5
UM600H.0022.6	22		90	115	4	64	UM600H.M6	UM600H.K	2 Nm	6
UM600H.0022.7	22		90	115	4	64	UM600H.M7	UM600H.K	2 Nm	7
↳ ...										

ULTRAMINI

Bohrungsbearbeitung
ab Ø 0.2 mm

grooving, boring and profiling
starting at Ø 0.2 mm

Typ UM600H

High-Performance-Klemmhalter
mit Kühlmittelsanschluss

high-performance toolholder
with coolant connection

Ø 12 - 28 mm
für Schneideinsatz mit
D min. 0.2 - 7.0 mm

Ø 12 - 28 mm
for insert with
D min. 0.2 - 7.0 mm

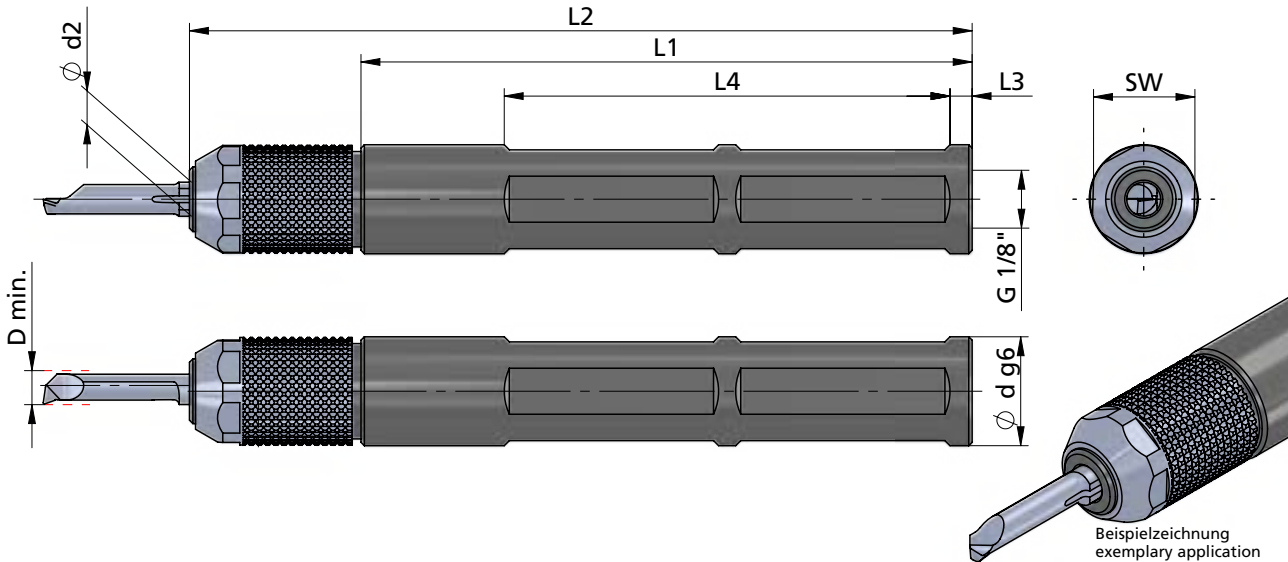

Klemmhalter für rechte und linke
Schneideinsätze einsetzbar

toolholder for right and left
inserts usable

Abmessungen in mm

dimensions in mm



Bestellnummer part number	Ø d g6	Ø d (inch)	L1	L2	L3	L4	Überwurfmutter union nut	Klemmkeil nut	Anzugs- drehmoment torque	Ø d2 Ø d h6 Schneideinsatz insert
...										
UM600H.0025.4	25		90	115	4	64	UM600H.M4	UM600H.K	2 Nm	4
UM600H.0025.5	25		90	115	4	64	UM600H.M5	UM600H.K	2 Nm	5
UM600H.0025.6	25		90	115	4	64	UM600H.M6	UM600H.K	2 Nm	6
UM600H.0025.7	25		90	115	4	64	UM600H.M7	UM600H.K	2 Nm	7
UM600H.00254.4	25.4	1"	90	115	4	64	UM600H.M4	UM600H.K	2 Nm	4
UM600H.00254.5	25.4	1"	90	115	4	64	UM600H.M5	UM600H.K	2 Nm	5
UM600H.00254.6	25.4	1"	90	115	4	64	UM600H.M6	UM600H.K	2 Nm	6
UM600H.00254.7	25.4	1"	90	115	4	64	UM600H.M7	UM600H.K	2 Nm	7
UM600H.0028.4	28		90	115	4	64	UM600H.M4	UM600H.K	2 Nm	4
UM600H.0028.5	28		90	115	4	64	UM600H.M5	UM600H.K	2 Nm	5
UM600H.0028.6	28		90	115	4	64	UM600H.M6	UM600H.K	2 Nm	6
UM600H.0028.7	28		90	115	4	64	UM600H.M7	UM600H.K	2 Nm	7

Bestellbeispiel:
UM600H.0025.4

order-example:
UM600H.0025.4

ULTRAMINI

Bohrungsbearbeitung
ab $\varnothing 0.2$ mm

grooving, boring and profiling
starting at $\varnothing 0.2$ mm

Typ UM600H.S

High-Performance-Klemmhalter,
kurze Ausführung
mit Kühlmittelanschluss

high-performance toolholder,
short version
with coolant connection

$\varnothing 16 - 25.4$ mm
für Schneideinsatz mit
D min. 0.2 - 7.0 mm

$\varnothing 16 - 25.4$ mm
for insert with
D min. 0.2 - 7.0 mm

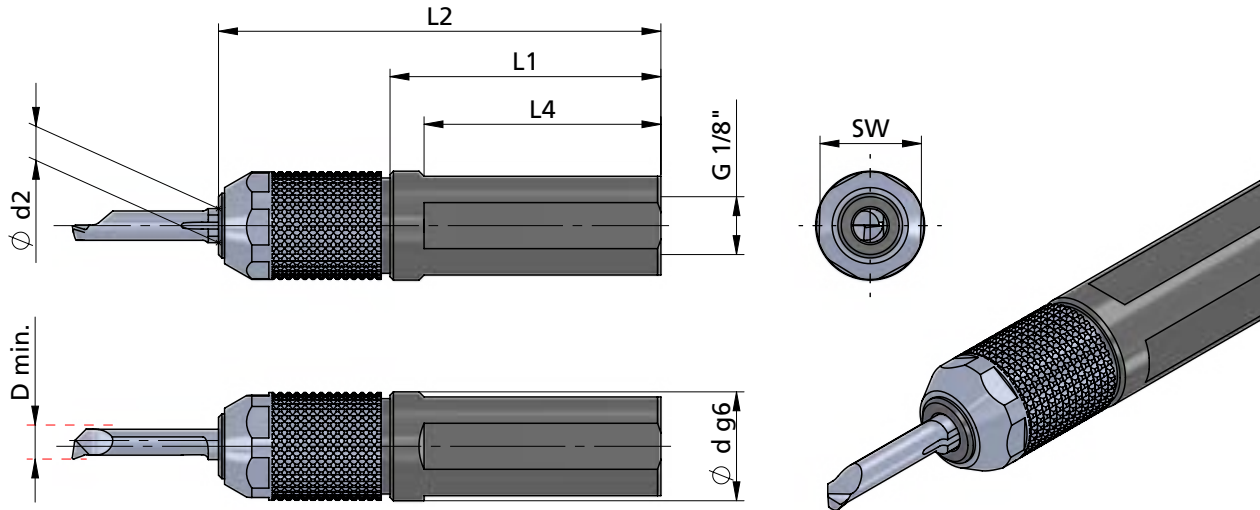

Beispielzeichnung
exemplary application

Klemmhalter für rechte und linke
Schneideinsätze einsetzbar

toolholder for right and left
inserts usable

Abmessungen in mm

dimensions in mm



Bestellnummer part number	$\varnothing d$ g6	$\varnothing d$ (inch)				Überwurfmutter union nut	Klemmkeil nut	Anzugs- drehmoment torque	Schneideinsatz insert	
			L1	L2	L4				$\varnothing d2$	$\varnothing d$ h6
UM600H.S016.4	16		40.0	65	35.0	UM600H.M4	UM600H.K	2 Nm	4	
UM600H.S016.5	16		40.0	65	35.0	UM600H.M5	UM600H.K	2 Nm	5	
UM600H.S016.6	16		40.0	65	35.0	UM600H.M6	UM600H.K	2 Nm	6	
UM600H.S016.7	16		42.5	65	37.5	UM600H.M7	UM600H.K	2 Nm	7	
UM600H.S01905.4	19.05	3/4"	40.0	65	33.0	UM600H.M4	UM600H.K	2 Nm	4	
UM600H.S01905.5	19.05	3/4"	40.0	65	33.0	UM600H.M5	UM600H.K	2 Nm	5	
UM600H.S01905.6	19.05	3/4"	40.0	65	34.0	UM600H.M6	UM600H.K	2 Nm	6	
UM600H.S01905.7	19.05	3/4"	40.0	65	34.0	UM600H.M7	UM600H.K	2 Nm	7	

Merkmale:

- Handspannung ohne zusätzlichen Schlüssel
- Wiederholgenauigkeit $\pm 0,005$ mm (hohe Präzision)
- einfachste Bedienung
- ideal bei engen Platzverhältnissen
- Spannung mit Standardschlüssel SW15 möglich
- beim Einsatz als Rückwärtsdreher oder mit Hochdruckkühlung wird empfohlen nach handfester Spannung zusätzlich mit Schlüssel SW15 (1/4 Umdrehung) zu spannen

characteristics:

- manual clamping without additional wrench
- continuous repeatability $\pm 0,005$ mm (high precision)
- simplest operation
- ideal where space is tight
- clamping by standard wrench SW15 is possible
- if used for back turning or with high pressure coolant: After tightening hand tight it is recommended to additionally tighten the clamp with a wrench (size 15 mm) by 1/4 turn

ULTRAMINI

Bohrungsbearbeitung
ab $\varnothing 0.2 \text{ mm}$

grooving, boring and profiling
starting at $\varnothing 0.2 \text{ mm}$

Typ UM600H.S

High-Performance-Klemmhalter,
kurze Ausführung
mit Kühlmittelanschluss

high-performance toolholder,
short version
with coolant connection

$\varnothing 16 - 25.4 \text{ mm}$
für Schneideinsatz mit
D min. $0.2 - 7.0 \text{ mm}$

$\varnothing 16 - 25.4 \text{ mm}$
for insert with
D min. $0.2 - 7.0 \text{ mm}$

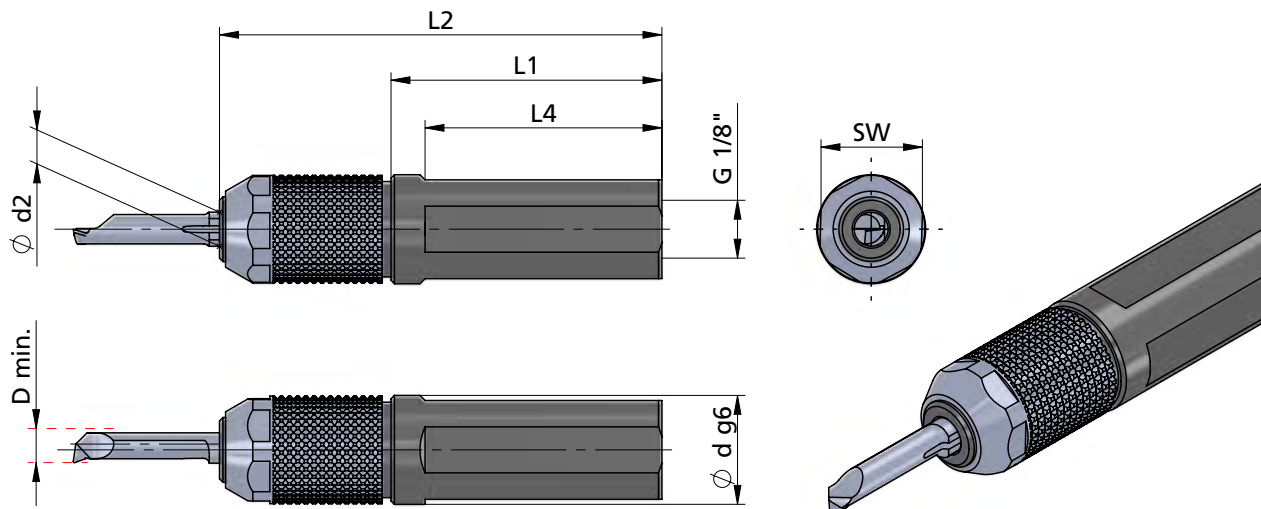

Beispielzeichnung
exemplary application

Klemmhalter für rechte und linke
Schneideinsätze einsetzbar

toolholder for right and left
inserts usable



Abmessungen in mm

dimensions in mm

Bestellnummer part number	$\varnothing d_{g6}$	$\varnothing d$ (inch)	L1	L2	L4	Überwurfmutter union nut	Klemmkeil nut	Anzugs- drehmoment torque	$\varnothing d_2$ \leq $\varnothing d_{h6}$ Schneideinsatz insert
...									
UM600H.S020.4	20		40.0	65	32.0	UM600H.M4	UM600H.K	2 Nm	4
UM600H.S020.5	20		40.0	65	33.0	UM600H.M5	UM600H.K	2 Nm	5
UM600H.S020.6	20		40.0	65	34.0	UM600H.M6	UM600H.K	2 Nm	6
UM600H.S020.7	20		40.0	65	34.0	UM600H.M7	UM600H.K	2 Nm	7
UM600H.S022.4	22		40.0	65	32.0	UM600H.M4	UM600H.K	2 Nm	4
UM600H.S022.5	22		40.0	65	32.0	UM600H.M5	UM600H.K	2 Nm	5
UM600H.S022.6	22		40.0	65	32.0	UM600H.M6	UM600H.K	2 Nm	6
UM600H.S022.7	22		40.0	65	34.0	UM600H.M7	UM600H.K	2 Nm	7
UM600H.S025.4	25		40.0	65	32.0	UM600H.M4	UM600H.K	2 Nm	4
UM600H.S025.5	25		40.0	65	32.0	UM600H.M5	UM600H.K	2 Nm	5
UM600H.S025.6	25		40.0	65	32.0	UM600H.M6	UM600H.K	2 Nm	6
UM600H.S025.7	25		40.0	65	32.0	UM600H.M7	UM600H.K	2 Nm	7
↳ ...									

Bestellbeispiel:
UM600H.S020.4

order-example:
UM600H.S020.4

ULTRAMINI

Bohrungsbearbeitung
ab $\varnothing 0.2$ mm

grooving, boring and profiling
starting at $\varnothing 0.2$ mm

Typ UM600H.S

High-Performance-Klemmhalter,
kurze Ausführung
mit Kühlmittelanschluss

high-performance toolholder,
short version
with coolant connection

$\varnothing 16 - 25.4$ mm
für Schneideinsatz mit
D min. 0.2 - 7.0 mm

$\varnothing 16 - 25.4$ mm
for insert with
D min. 0.2 - 7.0 mm

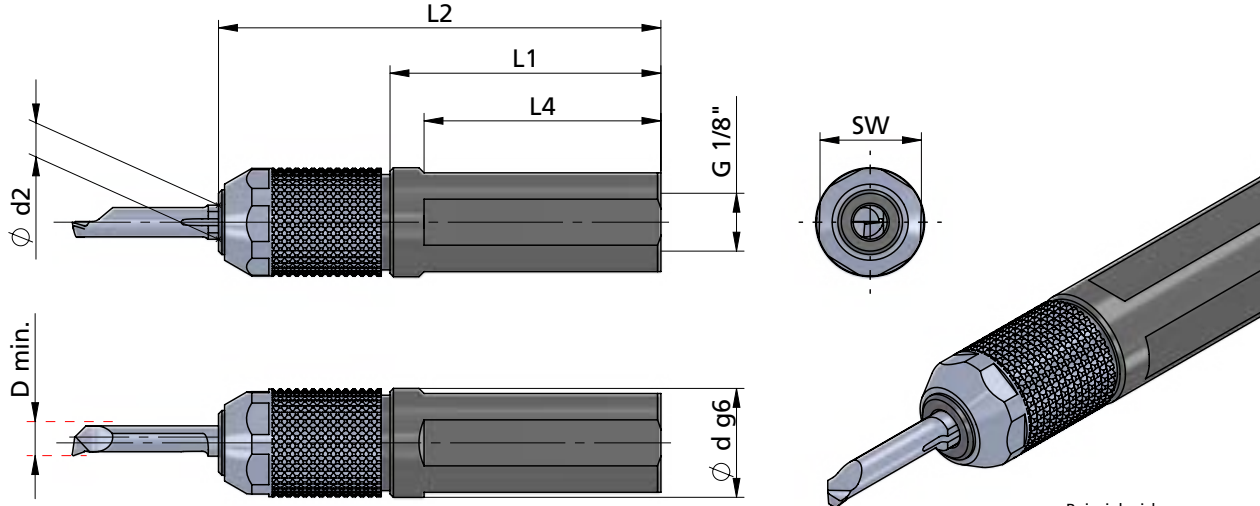

Beispielzeichnung
exemplary application

Klemmhalter für rechte und linke
Schneideinsätze einsetzbar

toolholder for right and left
inserts usable

Abmessungen in mm

dimensions in mm



Bestellnummer part number	Abmessungen in mm					Überwurfmutter union nut	Klemmkeil nut	Anzugs- drehmoment torque	Schneideinsatz insert
	$\varnothing d_{g6}$	$\varnothing d$ (inch)	L1	L2	L4				
...									
UM600H.S0254.4	25.4	1"	40.0	65	30.0	UM600H.M4	UM600H.K	2 Nm	4
UM600H.S0254.5	25.4	1"	40.0	65	30.0	UM600H.M5	UM600H.K	2 Nm	5
UM600H.S0254.6	25.4	1"	40.0	65	31.0	UM600H.M6	UM600H.K	2 Nm	6
UM600H.S0254.7	25.4	1"	40.0	65	31.0	UM600H.M7	UM600H.K	2 Nm	7

ULTRAMINI

Bohrungsbearbeitung
ab Ø 0.2 mm

grooving, boring and profiling
starting at Ø 0.2 mm

Typ UM

Klemmhalter,
Quadratschaft

toolholder,
square shank

ab 10.0 x 10.0 mm
für Schneideinsätze
D min. 0.2 - 7.0 mm

starting at 10.0 x 10.0 mm
for insert
D min. 0.2 - 7.0 mm

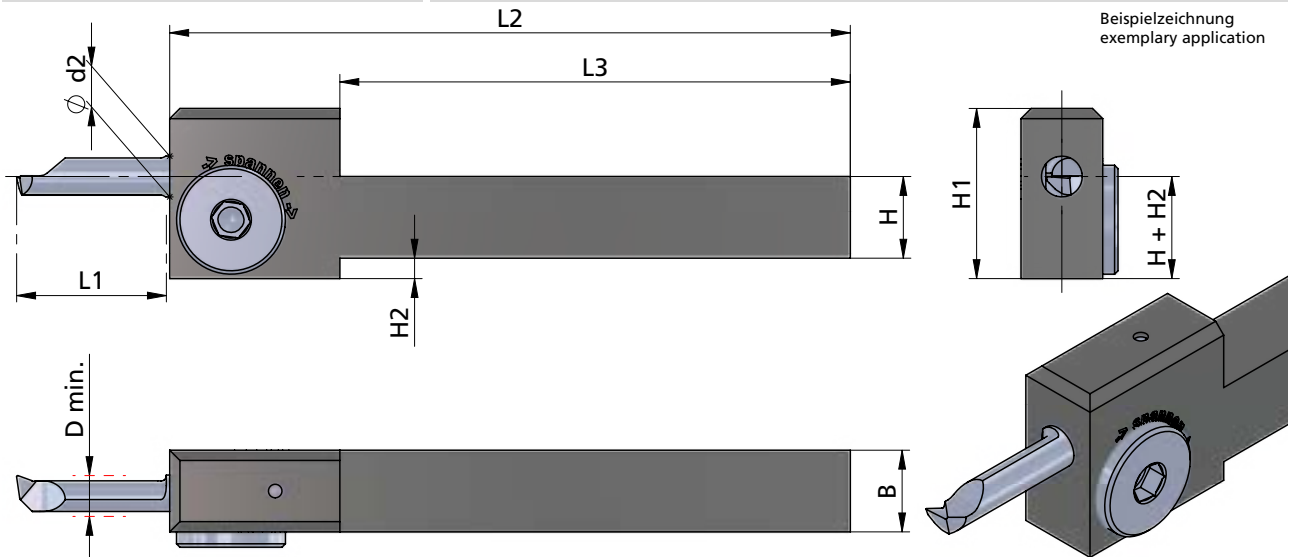

Klemmhalter für rechte und linke
Schneideinsätze einsetzbar

Spannschraube 180° drehen für
Wechsel R auf L Schneide

Abmessungen in mm

toolholder for right and left
inserts usable

clamping screw rotate 180° for
change R to L insert

dimensions in mm

Bestellnummer part number	H	B	L2	L3	H1	H2	L1 Schneide / insert	Klemmelement locking element	Schraubenschlüssel wrench	Anzugs- drehmoment torque	Ø d2 Ø d h6 Schneideinsatz insert
UM.1010.4	10	10	100	75	22	2		UM12	111.INB5	2.0 Nm	4
UM.1010.5	10	10	100	75	22	2		UM12	111.INB5	2.0 Nm	5
UM.1212.4	12	12	100	75	22			UM12	111.INB5	2.0 Nm	4
UM.1212.5	12	12	100	75	22			UM12	111.INB5	2.0 Nm	5
UM.1212.6	12	12	100	75	25	3	-2	UM16	111.INB5	2.0 Nm	6
UM.1616.4	16	16	125	100	25			UM12	111.INB5	2.0 Nm	4
UM.1616.5	16	16	125	100	25			UM12	111.INB5	2.0 Nm	5
UM.1616.6	16	16	125	100	25		-2	UM16	111.INB5	2.0 Nm	6
UM.1616.7	16	16	125	100	25		-2	UM16	111.INB5	2.0 Nm	7

Bestellbeispiel:
UM.1010.4

order-example:
UM.1010.4

ULTRAMINI

Bohrungsbearbeitung
ab $\varnothing 0.2$ mm

grooving, boring and profiling
starting at $\varnothing 0.2$ mm

Typ .IK.UHCM

Klemmhalter,
Quadratschaft,
mit Innenkühlung

toolholder,
square shank,
with internal cooling

ab 12.0 x 12.0 mm
für Schneideinsätze
D min. 0.2 - 7.0 mm

starting at 12.0 x 12.0 mm
for insert
D min. 0.2 - 7.0 mm

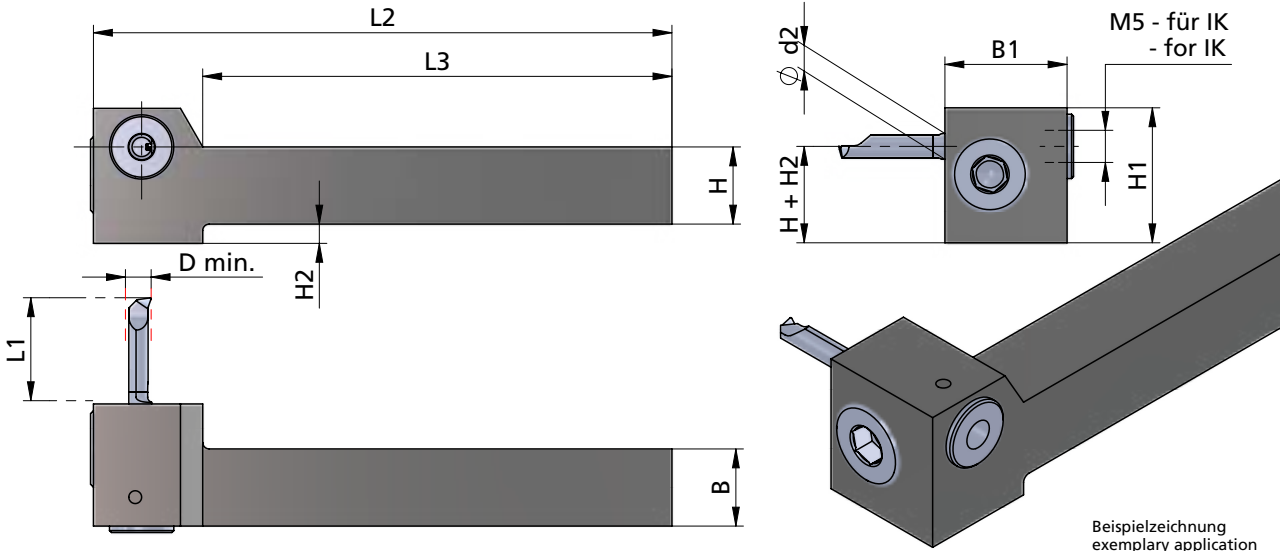

Beispielzeichnung
exemplary application

Klemmhalter für rechte und linke
Schneideinsätze einsetzbar

Abbildung: linksschneidend

Abmessungen in mm

toolholder for right and left
inserts usable

lefthand version shown

dimensions in mm



Bestellnummer part number	H	H (inch)	B	B (inch)	L2	L3	B1	H1	H2	L1	Schneide/insert	Klemmelement locking element	Schraubenschlüssel wrench	Anzugs- drehmoment torque	$\varnothing d2$	$\varnothing d$ h6 insert/ Schneideinsatz
R/L .IK.UHCM.1212.4	12		12		90	73	20	18				UM12	111.INB5	2.0 Nm		4
R/L .IK.UHCM.0.500.4	12.7	1/2"	12.7	1/2"	90	73	20	18				UM12	111.INB5	2.0 Nm		4
R/L .IK.UHCM.1212.5	12		12		90	73	20	18				UM12	111.INB5	2.0 Nm		5
R/L .IK.UHCM.0.500.5	12.7	1/2"	12.7	1/2"	90	73	20	18				UM12	111.INB5	2.0 Nm		5
R/L .IK.UHCM.1212.6	12		12		90	73	20	21	3	-2		UM16	111.INB5	2.0 Nm		6
R/L .IK.UHCM.0.500.6	12.7	1/2"	12.7	1/2"	90	73	20	21	3	-2		UM16	111.INB5	2.0 Nm		6
R/L .IK.UHCM.1212.7	12		12		90	73	20	21	3	-2		UM16	111.INB5	2.0 Nm		7
R/L .IK.UHCM.0.500.7	12.7	1/2"	12.7	1/2"	90	73	20	21	3	-2		UM16	111.INB5	2.0 Nm		7
↳ ...																

Kühlmitteldruck max. 10 bar

Coolant pressure max. 10 bar

ULTRAMINI

Bohrungsbearbeitung
ab Ø 0.2 mm

grooving, boring and profiling
starting at Ø 0.2 mm

Typ .IK.UHCM

Klemmhalter,
Quadratschaft,
mit Innenkühlung

toolholder,
square shank,
with internal cooling

ab 12.0 x 12.0 mm
für Schneideinsätze
D min. 0.2 - 7.0 mm

starting at 12.0 x 12.0 mm
for insert
D min. 0.2 - 7.0 mm

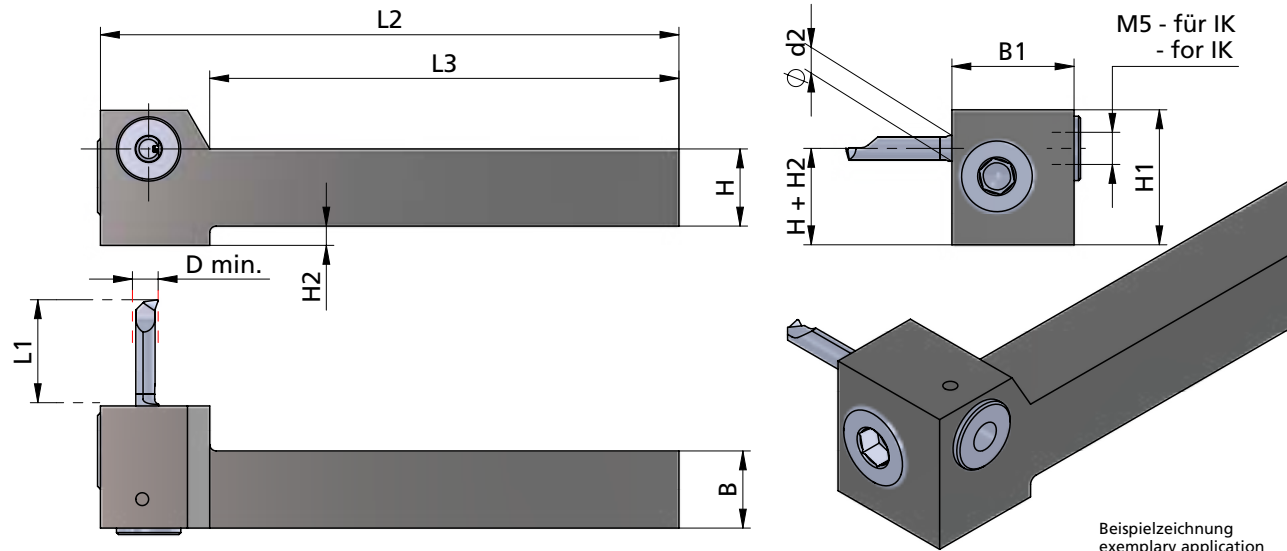

Beispielzeichnung
exemplary application

Klemmhalter für rechte und linke
Schneideinsätze einsetzbar

Abbildung: linksschneidend

Abmessungen in mm

toolholder for right and left
inserts usable

lefthand version shown

dimensions in mm



Bestellnummer part number	H	H (inch)	B	B (inch)	L2	L3	B1	H1	H2	L1 Schneide/insert	Klemmelement locking element	Schraubenschlüssel wrench	Anzugs- drehmoment torque	Ø d2 Ø d h6 insert/ Schneideinsatz
...														
R/L .IK.UHCM.0.625.4	15.87	5/8"	15.87	5/8"	130	113	20	22			UM12	111.INB5	2.0 Nm	4
R/L .IK.UHCM.1616.4	16		16		130	113	20	22			UM12	111.INB5	2.0 Nm	4
R/L .IK.UHCM.0.625.5	15.87	5/8"	15.87	5/8"	130	113	20	22			UM12	111.INB5	2.0 Nm	5
R/L .IK.UHCM.1616.5	16		16		130	113	20	22			UM12	111.INB5	2.0 Nm	5
R/L .IK.UHCM.0.625.6	15.87	5/8"	15.87	5/8"	130	113	20	22	-2		UM16	111.INB5	2.0 Nm	6
R/L .IK.UHCM.1616.6	16		16		130	113	20	22	-2		UM16	111.INB5	2.0 Nm	6
R/L .IK.UHCM.0.625.7	15.87	5/8"	15.87	5/8"	130	113	20	22	-2		UM16	111.INB5	2.0 Nm	7
R/L .IK.UHCM.1616.7	16		16		130	113	20	22	-2		UM16	111.INB5	2.0 Nm	7

Kühlmittldruck max. 10 bar

Coolant pressure max. 10 bar

Bestellbeispiel:
R.IK.UHCM.0.625.4

order-example:
R.IK.UHCM.0.625.4

ULTRAMINI

Bohrungsbearbeitung
ab $\varnothing 0.2$ mm

grooving, boring and profiling
starting at $\varnothing 0.2$ mm

Typ .UM.18 / .UM.28

Klemmhalter,
Quadratschaft,
mit Innenkühlung

toolholder,
square shank,
with internal cooling

10.0 x 10.0 mm
für Schneideinsätze
D min. 0.2 - 7.0 mm

10.0 x 10.0 mm
for insert
D min. 0.2 - 7.0 mm

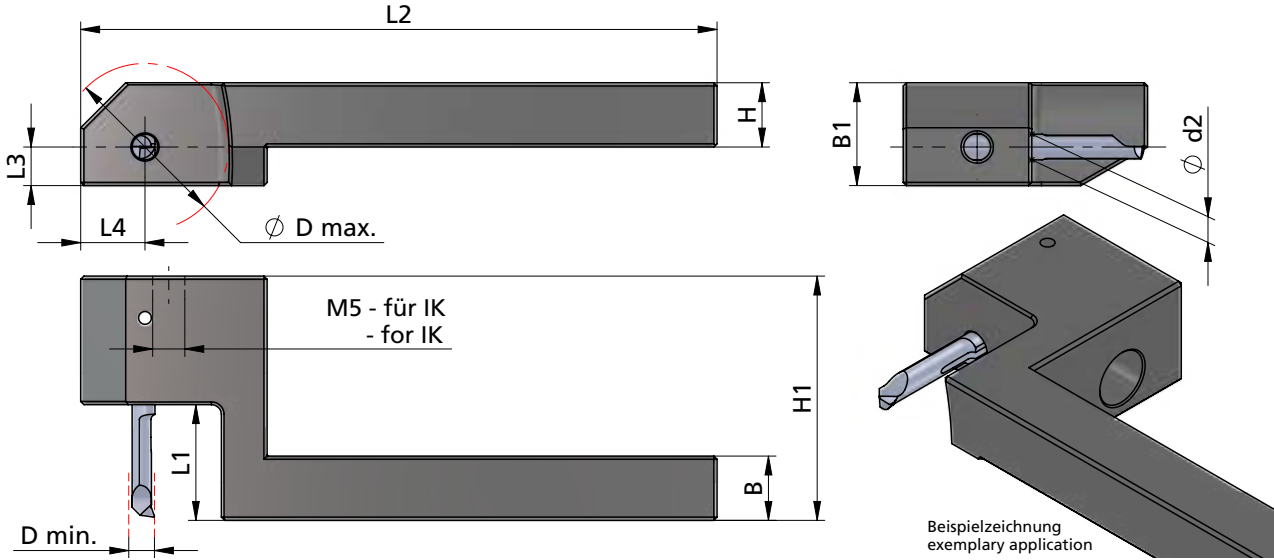
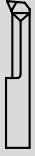

Rechts (R): wie gezeichnet
Links (L): spiegelbildlich

Rechte Schneidpl. in rechtem Halter
Linke Schneidpl. in linkem Halter

Abmessungen in mm

righthand version (R): as shown
lefthand version (L): mirror image

use RH insert in RH tool holder and
LH insert in LH tool holder

dimensions in mm



Bestellnummer part number	H	B	L2	L1	L3	L4	H1	B1	Ø D max.	Spannschraube screw	Schraubenschlüssel wrench	Anzugs- drehmoment torque	Schneideinsatz insert	
													Ø d2	Ø d h6
R/L .UM.18.1010.4	10	10	99	18	6	10	38	16	26	A.GST005	111.645	1.2 Nm	4	
R/L .UM.18.1010.5	10	10	99	18	6	10	38	16	26	A.GST005	111.645	1.2 Nm	5	
R/L .UM.18.1010.6	10	10	99	18	6	10	38	16	26	A.GST005	111.645	1.2 Nm	6	
R/L .UM.18.1010.7	10	10	99	18	6	10	38	16	26	A.GST005	111.645	1.2 Nm	7	
R/L .UM.28.1010.4	10	10	99	28	6	10	48	16	26	A.GST005	111.645	1.2 Nm	4	
R/L .UM.28.1010.5	10	10	99	28	6	10	48	16	26	A.GST005	111.645	1.2 Nm	5	
R/L .UM.28.1010.6	10	10	99	28	6	10	48	16	26	A.GST005	111.645	1.2 Nm	6	
R/L .UM.28.1010.7	10	10	99	28	6	10	48	16	26	A.GST005	111.645	1.2 Nm	7	

ULTRAMINI

Bohrungsbearbeitung
ab $\varnothing 0.2$ mm

grooving, boring and profiling
starting at $\varnothing 0.2$ mm

Typ .UM.18 / .UM.28

Klemmhalter,
Quadratschaft,
mit Innenkühlung

toolholder,
square shank,
with internal cooling

12.0 x 12.0 mm
für Schneideinsätze
D min. 0.2 - 7.0 mm

12.0 x 12.0 mm
for insert
D min. 0.2 - 7.0 mm

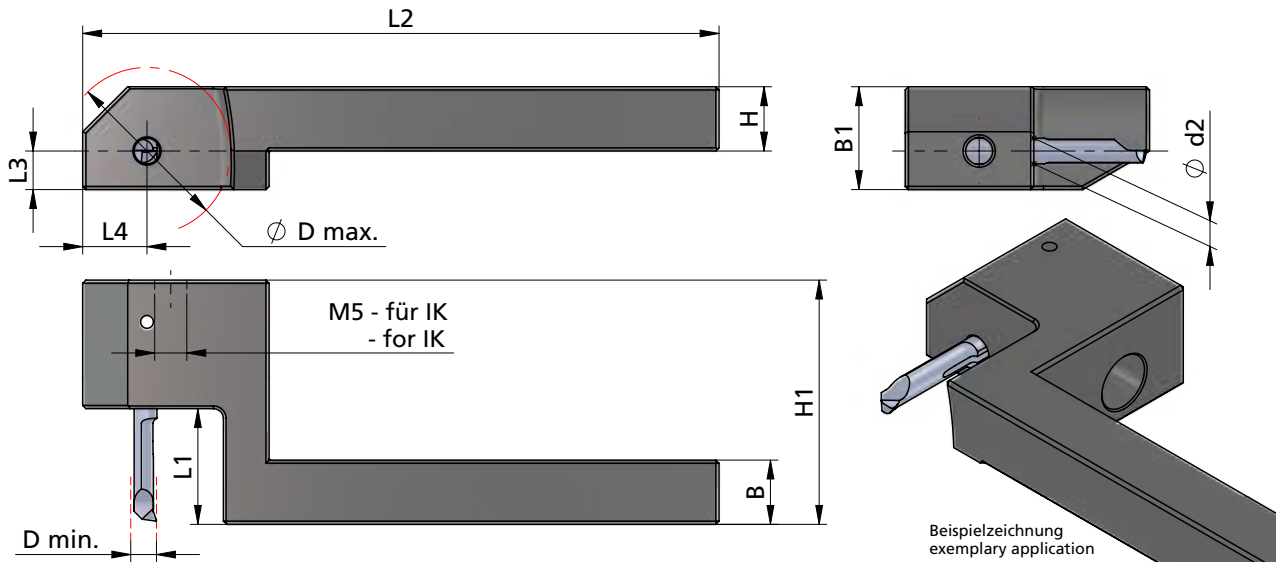

Rechts (R): wie gezeichnet
Links (L): spiegelbildlich

Rechte Schneidpl. in rechtem Halter
Linke Schneidpl. in linkem Halter

Abmessungen in mm

righthand version (R): as shown
lefthand version (L): mirror image

use RH insert in RH tool holder and
LH insert in LH tool holder

dimensions in mm



Bestellnummer part number	H	B	L2	L1	L3	L4	H1	B1	Ø D max.	Spannschraube screw	Schraubenschlüssel wrench	Anzugs- drehmoment torque	Schneideinsatz insert	
													Ø d2	Ø d h6
R/L .UM.18.1212.4	12	12	99	18	6	10	38	18	26	A.GST005	111.645	1.2 Nm	4	
R/L .UM.18.1212.5	12	12	99	18	6	10	38	18	26	A.GST005	111.645	1.2 Nm	5	
R/L .UM.18.1212.6	12	12	99	18	6	10	38	18	26	A.GST005	111.645	1.2 Nm	6	
R/L .UM.18.1212.7	12	12	99	18	6	10	38	18	26	A.GST005	111.645	1.2 Nm	7	
R/L .UM.28.1212.4	12	12	99	28	6	10	48	18	26	A.GST005	111.645	1.2 Nm	4	
R/L .UM.28.1212.5	12	12	99	28	6	10	48	18	26	A.GST005	111.645	1.2 Nm	5	
R/L .UM.28.1212.6	12	12	99	28	6	10	48	18	26	A.GST005	111.645	1.2 Nm	6	
R/L .UM.28.1212.7	12	12	99	28	6	10	48	18	26	A.GST005	111.645	1.2 Nm	7	

Bestellbeispiel:
für rechte Ausführung
R.UM.18.1212.4

order-example:
righthand version
R.UM.18.1212.4

ULTRAMINI

Bohrungsbearbeitung
ab $\varnothing 0.2$ mm

grooving, boring and profiling
starting at $\varnothing 0.2$ mm

Typ .TD0710

Klemmhalter,
Rechteckschaft
für Tornos DECO 7/10

toolholder,
rectangle shank
for Tornos DECO 7/10

25.0 x 26.0 mm
für Schneideinsätze
D min. 0.2 - 7.0 mm

25.0 x 26.0 mm
for insert
D min. 0.2 - 7.0 mm

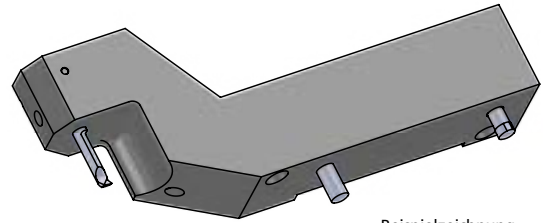
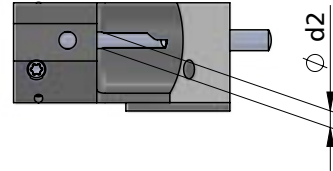
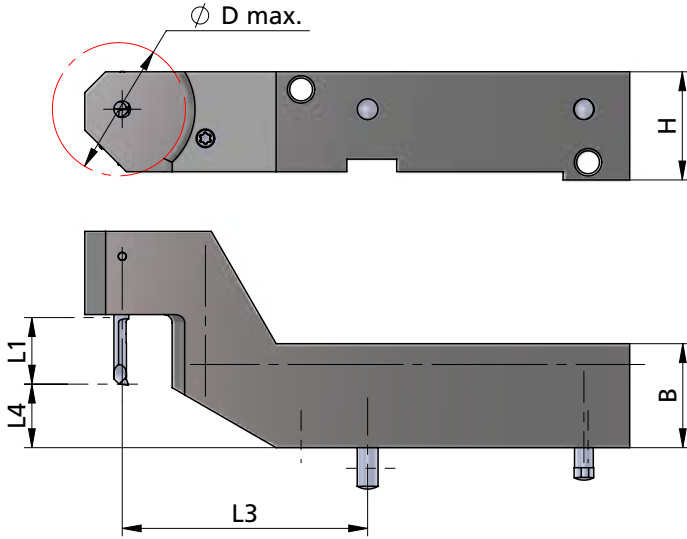

Beispielzeichnung
exemplary application

Rechts (R): wie gezeichnet
Links (L): spiegelbildlich

Rechte Schneidpl. in rechtem Halter
Linke Schneidpl. in linkem Halter

Abmessungen in mm

righthand version (R): as shown
lefthand version (L): mirror image

use RH insert in RH tool holder and
LH insert in LH tool holder

dimensions in mm

Bestellnummer part number	H	B	L1	L3	L4	Ø D max.	Spannschraube screw	Schraubenschlüssel wrench	Anzugs- drehmoment torque	Ø d2	Ø d h6	Schneideinsatz insert
										≤		
R/L .TD0710.16.4	26	25	16	59	15	32	A.GST008	111.645	1.2 Nm	4		
R/L .TD0710.16.5	26	25	16	59	15	32	A.GST008	111.645	1.2 Nm	5		
R/L .TD0710.16.6	26	25	16	59	15	32	A.GST008	111.645	1.2 Nm	6		
R/L .TD0710.16.7	26	25	16	59	15	32	A.GST008	111.645	1.2 Nm	7		

ULTRAMINI

Bohrungsbearbeitung
ab $\varnothing 0.2$ mm

grooving, boring and profiling
starting at $\varnothing 0.2$ mm

Typ UMHB

Klemmhalter und Reduzierhülse
für Rückseitenbearbeitung auf
Langdrehautomaten

toolholder and reduction bush
for rear end machining
on Swiss type lathes

$\varnothing 22 - 33$ mm
für Schneideinsatz
D min. ≥ 0.2 mm

$\varnothing 22 - 33$ mm
for insert
D min. ≥ 0.2 mm

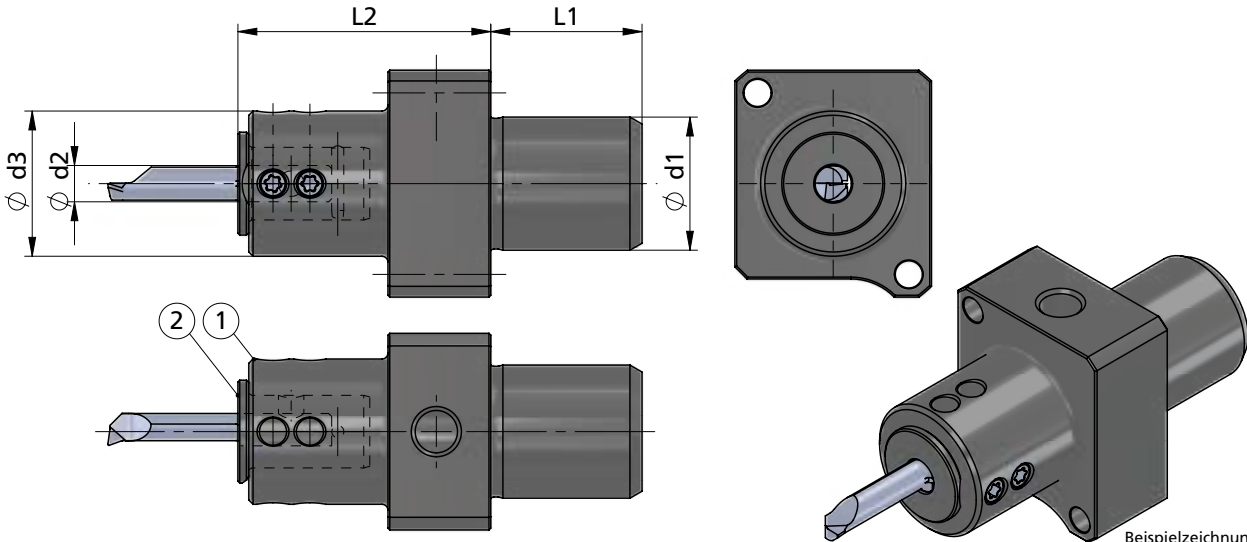

Beispielzeichnung
exemplary application

Weitere Klemmhalter
für nicht aufgeführte Maschinen
auf Anfrage lieferbar.

More toolholder
for not listed machines
are available on request.



Abmessungen in mm

dimensions in mm

Bestellnummer part number	Position	Bezeichnung description	$\varnothing d2$	$\varnothing d3$	$\varnothing d1$	L1	L2	Langdrehautomat Swiss type lathes	Spannschraube screw	Schraubenschlüssel wrench	Anzugs- drehmoment torque	$\varnothing d2$ \triangleleft $\varnothing d h6$ Schneideinsatz insert
UMHB-RH1222SRR			28	22	25	41.8		Star SR20R I / II / III / SB20	A.GST012	T10F	1.2 Nm	
UMHB-RH1222SW	1	Klemmhalter Innendrehen /	28	22	25	41.8		Star SW20 / SR20RIV	A.GST012	T10F	1.2 Nm	
UMHB-RH1228CT20		toolholder internal turning	25	28	35.5	41.8		Tornos CT20	A.GST012	T10F	1.2 Nm	
UMHB-RH1233HA20			24	33	37	34.8		Hanwha HA20	A.GST012	T10F	1.2 Nm	
UMHB-RBD1204			4									4
UMHB-RBD1205			5									5
UMHB-RBD1206	2	Reduzierhülse /	6									6
UMHB-RBD1207		reduction bush	7									7
UMHB-RBD1208			8									8
UMHB-RBD1210			10									10

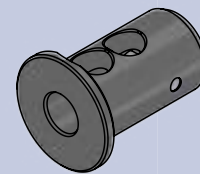

Bestellbeispiel:
UMHB-RH1222SRR + UMHB-RBD1204

order-example:
UMHB-RH1222SRR + UMHB-RBD1204

ULTRAMINI

Bohrungsbearbeitung
ab $\varnothing 0.2$ mm

grooving, boring and profiling
starting at $\varnothing 0.2$ mm

Typ UM.WFB

Klemmhalter und Reduzierhülse
mit WFB - Aufnahme

toolholder and reduction bush
with WFB - adapter

für Schneideinsatz
D min. ≥ 0.2 mm

for insert
D min. ≥ 0.2 mm

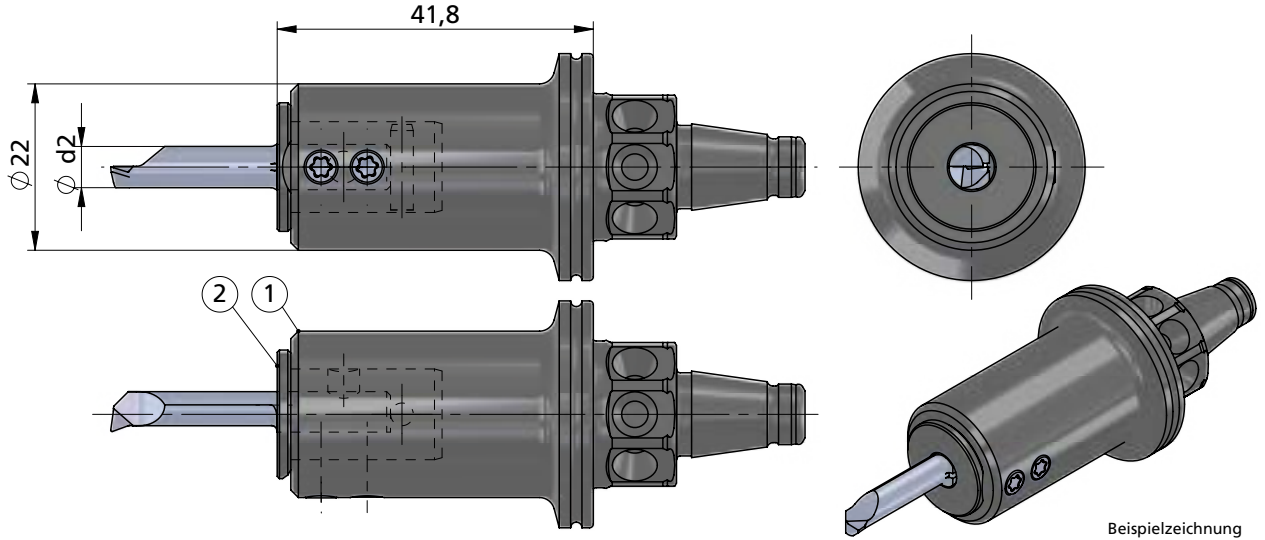

Beispielzeichnung
exemplary application

Abmessungen in mm

dimensions in mm

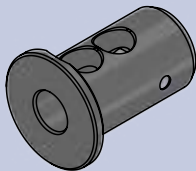

Bestellnummer part number	Position	Bezeichnung description	$\varnothing d2$	Spannschraube screw	Schraubenschlüssel wrench	Anzugs- drehmoment torque	$\varnothing d2$ $\varnothing d h6$ Schneideinsatz insert
UM.WFB.2240	1	Klemmhalter Innendrehen / toolholder internal turning		A.GST012	T10F	1.2 Nm	
				A.GST012	T10F	1.2 Nm	
				A.GST012	T10F	1.2 Nm	
				A.GST012	T10F	1.2 Nm	
UMHB-RBD1204	2	Reduzierhülse / reduction bush	4				4
UMHB-RBD1205			5				5
UMHB-RBD1206			6				6
UMHB-RBD1207			7				7
UMHB-RBD1208			8				8
UMHB-RBD1210			10				10

Reduzierhülse muss separat bestellt werden!

Reduction bush must be ordered separately!

ULTRAMINI

Bohrungsbearbeitung
ab $\varnothing 0.2 \text{ mm}$

grooving, boring and profiling
starting at $\varnothing 0.2 \text{ mm}$

Typ UM.C

Klemmhalter und Reduzierhülse
mit Polygonschaft
nach ISO 26623

toolholder and reduction bush
with polygon shank
according to ISO 26623

C3; C4
für Schneideinsatz
D min. $\geq 0.2 \text{ mm}$

C3; C4
for insert
D min. $\geq 0.2 \text{ mm}$

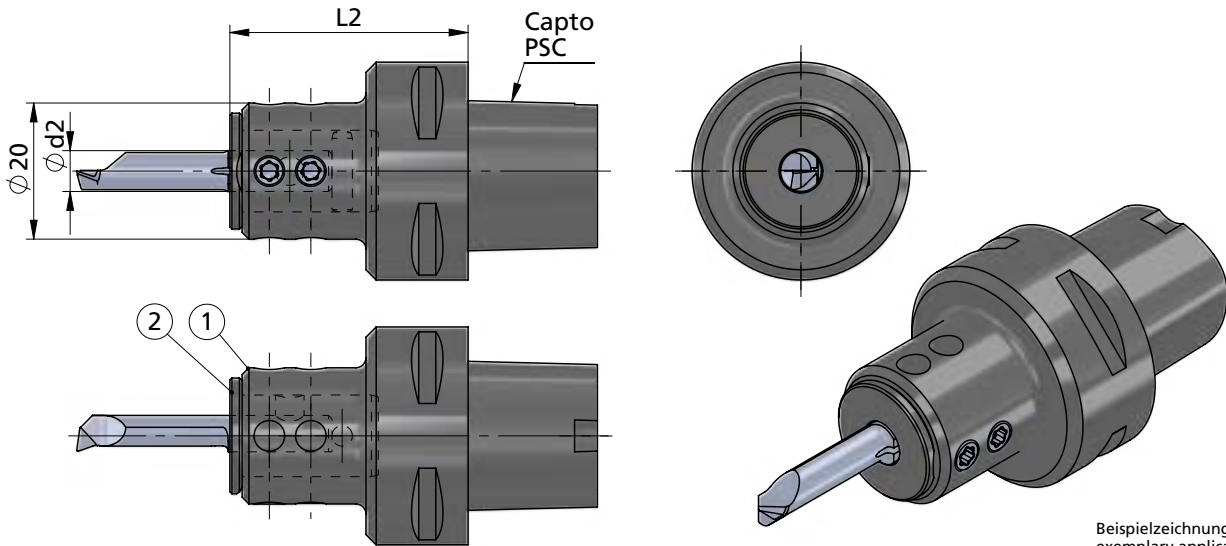

Abmessungen in mm

dimensions in mm



Bestellnummer part number	Position	Bezeichnung description	Polygonschaft polygon shank	$\varnothing d2$	L2	Spannschraube screw	Schraubenschlüssel wrench	Anzugs- drehmoment torque	Schneideinsatz insert	
									$\varnothing d2$	$\varnothing d h6$
UM.C3.2020	1	Klemmhalter Innendrehen / toolholder internal turning	C3	4	35	A.GST012	T10F	1.2 Nm		
UM.C4.2020			C4	5	40	A.GST012	T10F	1.2 Nm		
UMHB-RBD1204	2	Reduzierhülse / reduction bush		4					4	
UMHB-RBD1205			5		5					
UMHB-RBD1206			6		6					
UMHB-RBD1207			7		7					
UMHB-RBD1208			8		8					
UMHB-RBD1210			10		10					

Reduzierhülse muss separat bestellt werden!

Reduction bush must be ordered separately!

Bestellbeispiel:
UM.C3.2020 + UMHB-RBD1204

order-example:
UM.C3.2020 + UMHB-RBD1204

ULTRAMINI

Bohrungsbearbeitung
ab $\varnothing 0.2$ mm

grooving, boring and profiling
starting at $\varnothing 0.2$ mm

Typ UMHV

Höhenverstellbarer Klemmhalter und
Reduzierhülse für Rückseiten-
bearbeitung auf Langdrehautomaten

height adjustable toolholder and
reduction bush for rear end machining
on Swiss type lathes

für Schneideinsatz
D min. ≥ 0.2 mm

for insert
D min. ≥ 0.2 mm

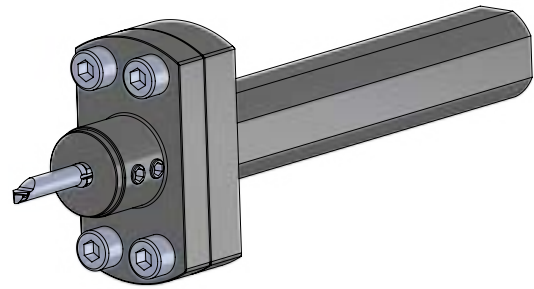
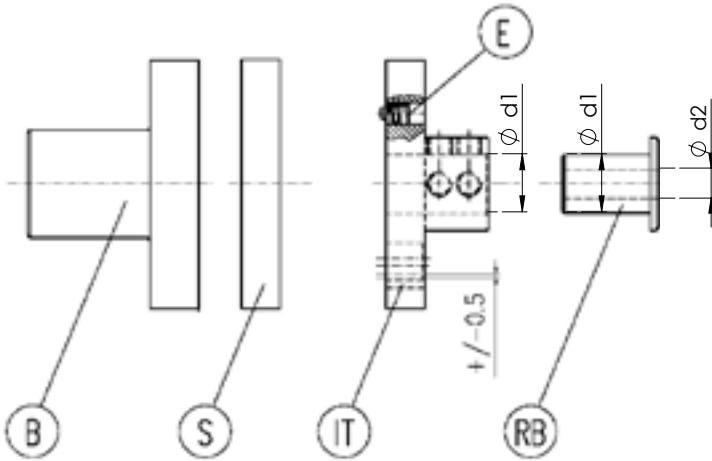

Beispielzeichnung
exemplary application

Abmessungen in mm

dimensions in mm

Bestellnummer part number	Position	Bezeichnung description	Ø		Ø d1 / Ø d2 Ø d h6 Schneideinsatz insert
			d1	d2	
UMHV-IT020110	IT		10		10
UMHV-IT050110	IT	Klemmhalter Innendrehen / toolholder internal turning	10		10
UMHV-IT90F0110	IT		10		10
UMHV-RBD1004	RB			4	4
UMHV-RBD1005	RB			5	5
UMHV-RBD1006	RB	Reduzierhülse / reduction bush		6	6
UMHV-RBD1007	RB			7	7
UMHV-RBD1008	RB			8	8
auf Anfrage / on request	B	Grundhalter / basic toolholder			
auf Anfrage / on request	S	Zwischenplatte / spacer			
auf Anfrage / on request	E	Excenter / excenter			

ULTRAMINI

Bohrungsbearbeitung
ab $\varnothing 0.2$ mm

grooving, boring and profiling
starting at $\varnothing 0.2$ mm

Typ UM.MASTER.

Ausrichthilfe für Klemmhalter

adjustment insert for toolholder

für Werkzeugschaft $\varnothing 4 - 8$ mm

for insert shank $\varnothing 4 - 8$ mm

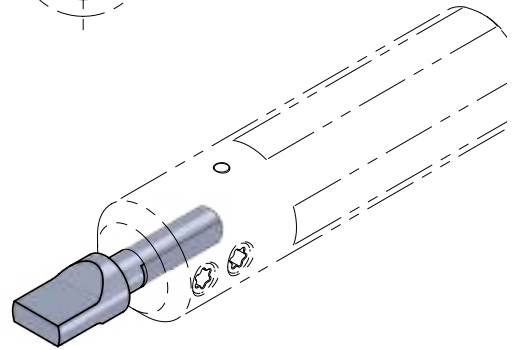
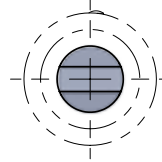
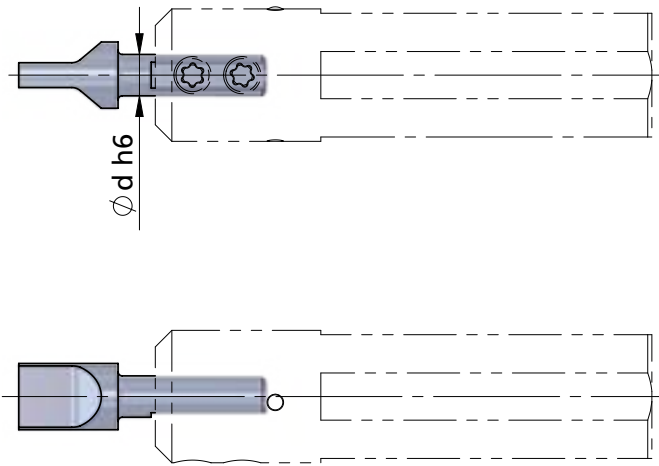

Beispielzeichnung
exemplary application

Abmessungen in mm

dimensions in mm

Bestellnummer part number	$\varnothing d h6$	K10F	Klemmhalter Typ toolholder type	
UM.MASTER.04	4	●	645,...	640,4
UM.MASTER.05	5	●		650,5
UM.MASTER.06	6	●		660,6
UM.MASTER.07	7	●	676,...	670, ... 687,7
UM.MASTER.08	8	●		680, ... 681, ... 687,8

Bestellbeispiel:
UM.MASTER.04

order-example:
UM.MASTER.04

ULTRAMINI

Bohrungsbearbeitung
ab \varnothing 0.2 mm

grooving, boring and profiling
starting at \varnothing 0.2 mm

Impressionen

impressions

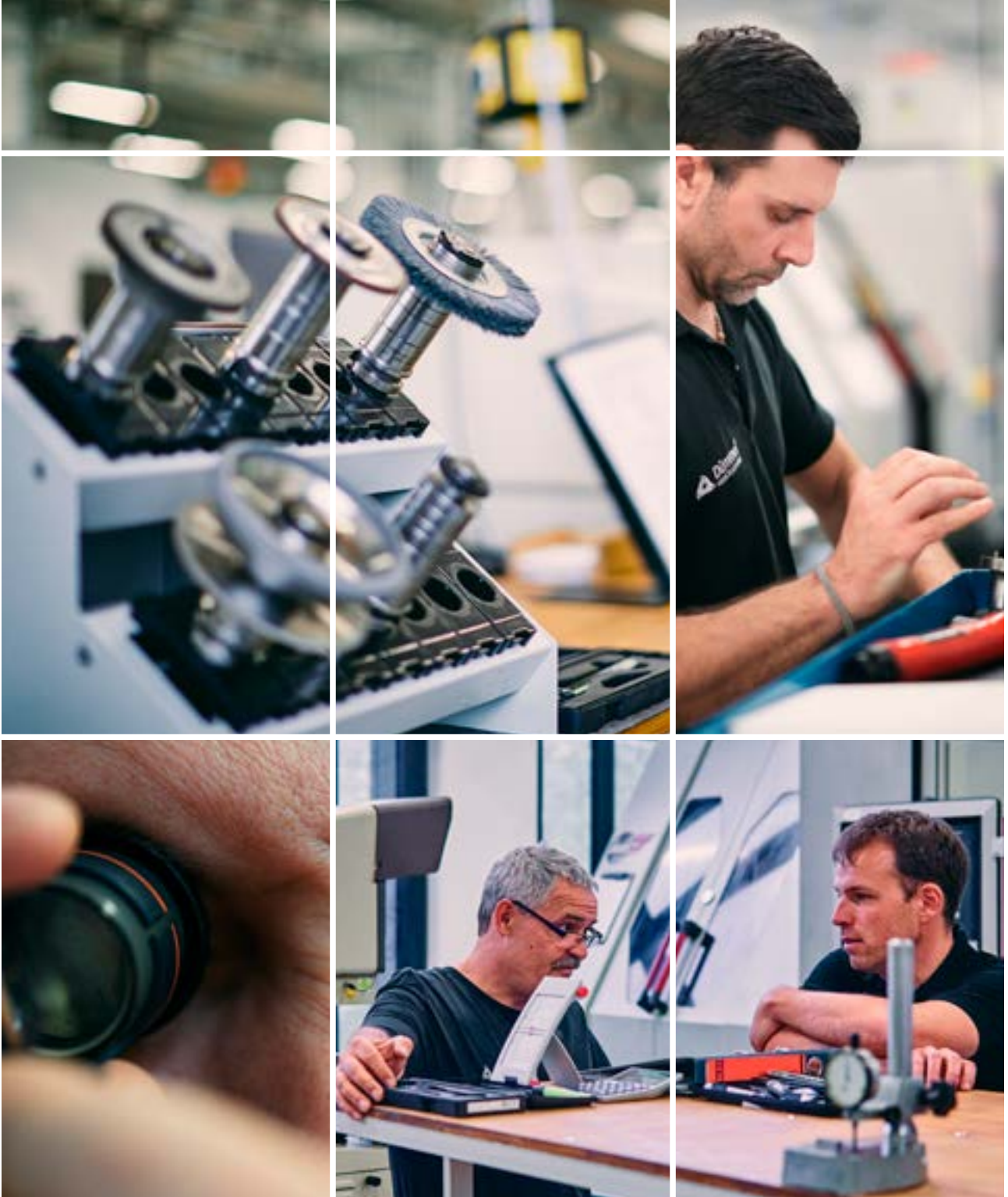

ULTRAMINI

Bohrungsbearbeitung
ab \varnothing 0.2 mm

grooving, boring and profiling
starting at \varnothing 0.2 mm

Typ 050

Audreihen und Kopieren

D min. 0.2 - 9.8 mm

boring and profiling

D min. 0.2 - 9.8 mm

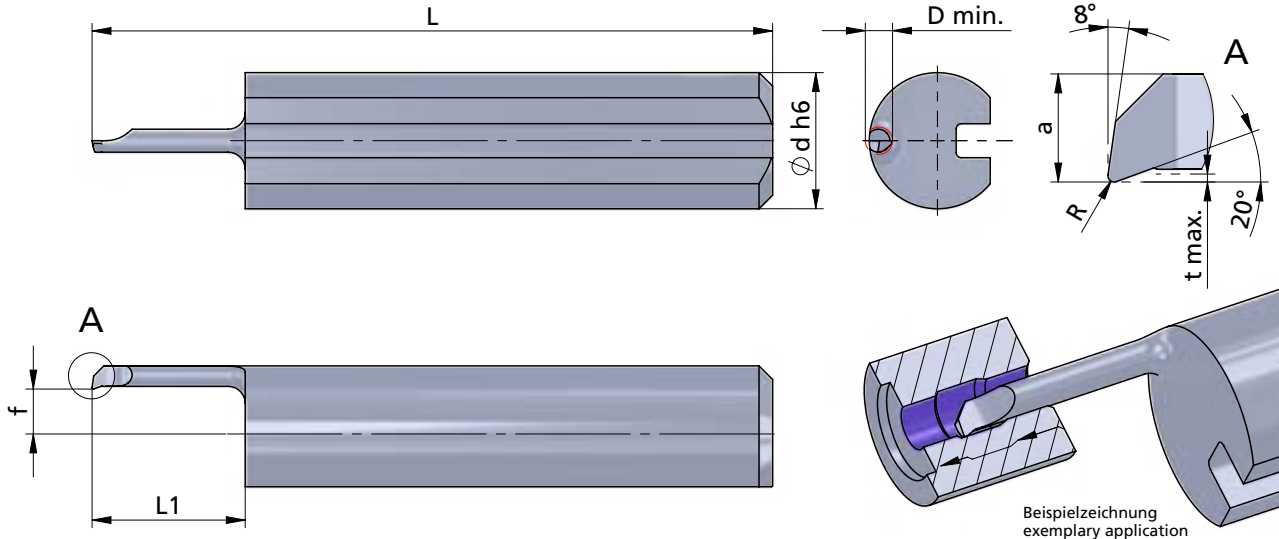

Rechts (R): wie gezeichnet
Links (L): spiegelbildlich

righthand (R): as shown
lefthand version (L): mirror image

*zentrisch aufgebaut

* central designed

Abmessungen in mm

dimensions in mm

Bestellnummer part number	R	f	a	L	L1	t max.	D min.	\varnothing d h6	K10F	CN45F	AL41F	PD2F	Klemmhalter Typ	toolholder type
													640... 645... ...4	
R/L 050.02-1 *	0.02	0.10	0.15	20	1.0	-	0.2	4.0	●					
R/L 050.03-1 *	0.02	0.15	0.27	20	1.2	-	0.3	4.0	●	●				
R/L 050.04-2 *	0.02	0.20	0.37	20	1.6	-	0.4	4.0	●	●				
R/L 050.05-2	0.04	-1.60	0.4	20	2.0	-	0.5	4.0		●	●			
R/L 050.06-2	0.04	-1.50	0.5	20	2.0	0.05	0.6	4.0		●	●			
R/L 050.06-3	0.04	-1.50	0.5	20	3.0	0.05	0.6	4.0		●	●			
R/L 050.08-4	0.04	-1.30	0.7	20	4.0	0.05	0.8	4.0		●	●			
R/L 050.1-5	0.05	-1.10	0.9	20	4.5	0.1	1.0	4.0		●	●			
R/L 050.1-7	0.05	-1.10	0.9	22	6.5	0.1	1.0	4.0		●	●			
R/L 050.1-8	0.05	-1.10	0.9	22	8.0	0.1	1.0	4.0		●	●			
R/L 050.15-5	0.05	-0.70	1.3	19	5.0	0.1	1.5	4.0		●	●			
R/L 050.15-10	0.05	-0.70	1.3	24	10.0	0.1	1.5	4.0		●	●			
R/L 050.15-12	0.05	-0.70	1.3	26	12.0	0.1	1.5	4.0		●				
↳ ...														

Weitere HM Sorten können Sie in der Sortenübersicht im Kapitel "Technische Hinweise" und der Preisliste finden.

More carbide grades you can find in the grades summary in the chapter "technical instructions" and in the price list.

Bestellbeispiel:
für rechte Ausführung und Sorte
R050.02-1/K10F

order-example:
righthand version and grade
R050.02-1/K10F

ULTRAMINI

Bohrungsbearbeitung
ab \varnothing 0.2 mm

grooving, boring and profiling
starting at \varnothing 0.2 mm

Typ 050

Audreihen und Kopieren

D min. 0.2 - 9.8 mm

boring and profiling

D min. 0.2 - 9.8 mm

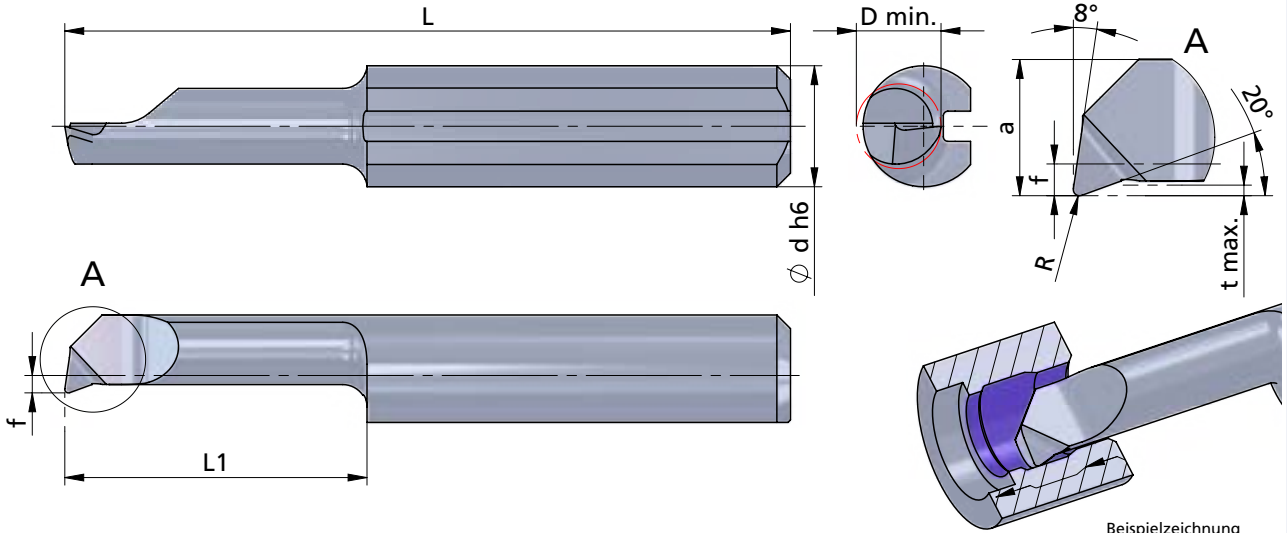

Beispielzeichnung
exemplary application

Rechts (R): wie gezeichnet
Links (L): spiegelbildlich

righthand (R): as shown
lefthand version (L): mirror image

Abmessungen in mm

dimensions in mm

Bestellnummer part number	R	f	a	L	L1	t max.	D min.	\varnothing d h6	K10F CN45F AL41F PD2F	Klemmhalter Typ	toolholder type		
...													
R/L 050.2-5	0.05	-0.3	1.7	19	5	0.1	2.0	4.0	● ● ●	640... 645... ...4			
R/L 050.2-10	0.05	-0.3	1.7	24	10	0.1	2.0	4.0	● ● ●				
R/L 050.2-15	0.05	-0.3	1.7	29	15	0.1	2.0	4.0	● ● ●				
R/L 050.25-5	0.05	0.2	2.2	19	5	0.15	2.5	4.0	● ● ●				
R/L 050.25-10	0.05	0.2	2.2	24	10	0.15	2.5	4.0	● ● ●				
R/L 050.25-16	0.05	0.2	2.2	30	16	0.15	2.5	4.0	● ● ●				
R/L 050.3-10	0.1	0.6	2.6	24	10	0.2	2.8	4.0	● ● ●				
R/L 050.3-16	0.1	0.6	2.6	30	16	0.2	2.8	4.0	● ● ●				
R/L 050.3-20	0.1	0.6	2.6	34	20	0.2	2.8	4.0	● ● ●				
R/L 050.35-10	0.1	1.1	3.1	24	10	0.25	3.5	4.0	● ● ●				
R/L 050.35-16	0.1	1.1	3.1	30	16	0.25	3.5	4.0	● ● ●				
R/L 050.35-20	0.1	1.1	3.1	34	20	0.25	3.5	4.0	● ● ●				
R/L 050.35-24	0.1	1.1	3.1	38	24	0.25	3.5	4.0	● ●				
↳ ...													

Weitere HM Sorten können Sie in der Sortenübersicht im Kapitel "Technische Hinweise" und der Preisliste finden.

More carbide grades you can find in the grades summary in the chapter "technical instructions" and in the price list.

ULTRAMINI

Bohrungsbearbeitung
ab $\varnothing 0.2$ mm

grooving, boring and profiling
starting at $\varnothing 0.2$ mm

Typ 050

Audreihen und Kopieren

D min. 0.2 - 9.8 mm

boring and profiling

D min. 0.2 - 9.8 mm

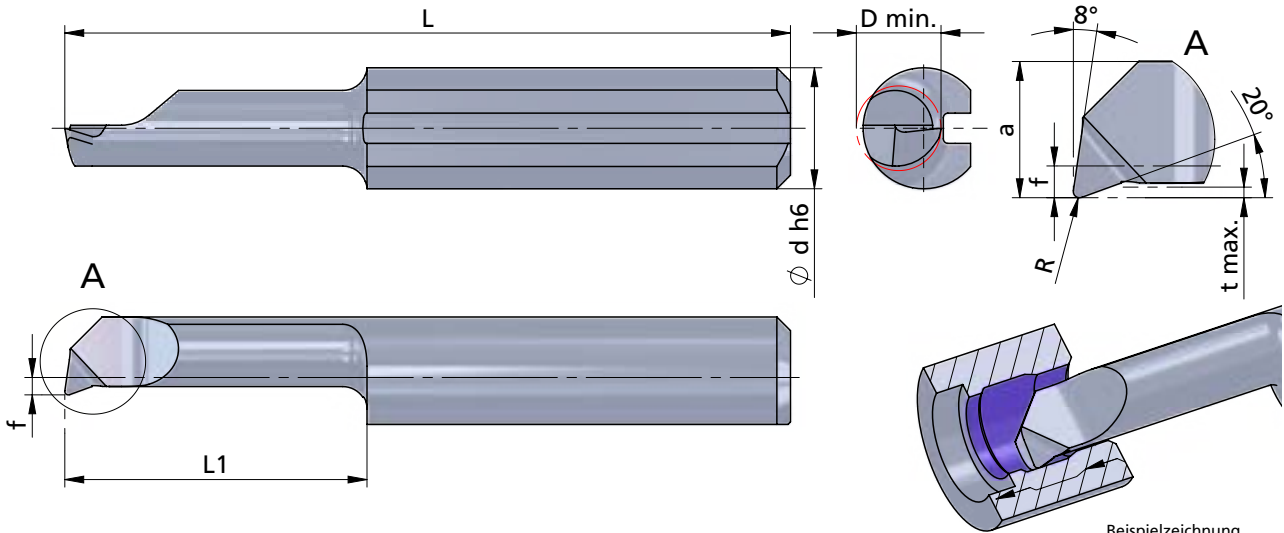

Beispielzeichnung
exemplary application

Rechts (R): wie gezeichnet
Links (L): spiegelbildlich

righthand (R): as shown
lefthand version (L): mirror image

Abmessungen in mm

dimensions in mm

Bestellnummer part number	R	f	a	L	L1	t max.	D min.	Ø d h6	K10F CN45F AL41F PD2F	Klemmhalter Typ toolholder type
⋮ ↴										
R/L 050.4-10	0.1	1.5	3.5	24	10	0.3	4.0	4.0	● ● ●	645, ...
R/L 050.4-16	0.1	1.5	3.5	30	16	0.3	4.0	4.0	● ● ●	
R/L 050.4-20	0.1	1.5	3.5	34	20	0.3	4.0	4.0	● ● ●	
R/L 050.4-24	0.1	1.5	3.5	38	24	0.3	4.0	4.0	● ● ●	
R/L 050.4-28	0.1	1.5	3.5	42	28	0.3	4.0	4.0	● ●	
R/L 050.5-10	0.15	1.9	4.4	25	10	0.5	5.0	5.0	● ● ●	645, ...
R/L 050.5-15	0.15	1.9	4.4	30	15	0.5	5.0	5.0	● ● ●	
R/L 050.5-20	0.15	1.9	4.4	35	20	0.5	5.0	5.0	● ● ●	
R/L 050.5-25	0.15	1.9	4.4	40	25	0.5	5.0	5.0	● ● ●	
R/L 050.5-30	0.15	1.9	4.4	45	30	0.5	5.0	5.0	● ● ●	
R/L 050.5-35	0.15	1.9	4.4	50	35	0.5	5.0	5.0	● ●	
R/L 050.5-40	0.15	1.9	4.4	55	40	0.5	5.0	5.0	● ●	
↳ ...										

Weitere HM Sorten können Sie in der Sortenübersicht im Kapitel "Technische Hinweise" und der Preisliste finden.

Bestellbeispiel:
für rechte Ausführung und Sorte
R050.4-10/AL41F

More carbide grades you can find in the grades summary in the chapter "technical instructions" and in the price list.

order-example:
righthand version and grade
R050.4-10/AL41F

ULTRAMINI

Bohrungsbearbeitung
ab $\varnothing 0.2$ mm

grooving, boring and profiling
starting at $\varnothing 0.2$ mm

Typ 050

Audreihen und Kopieren

D min. 0.2 - 9.8 mm

boring and profiling

D min. 0.2 - 9.8 mm

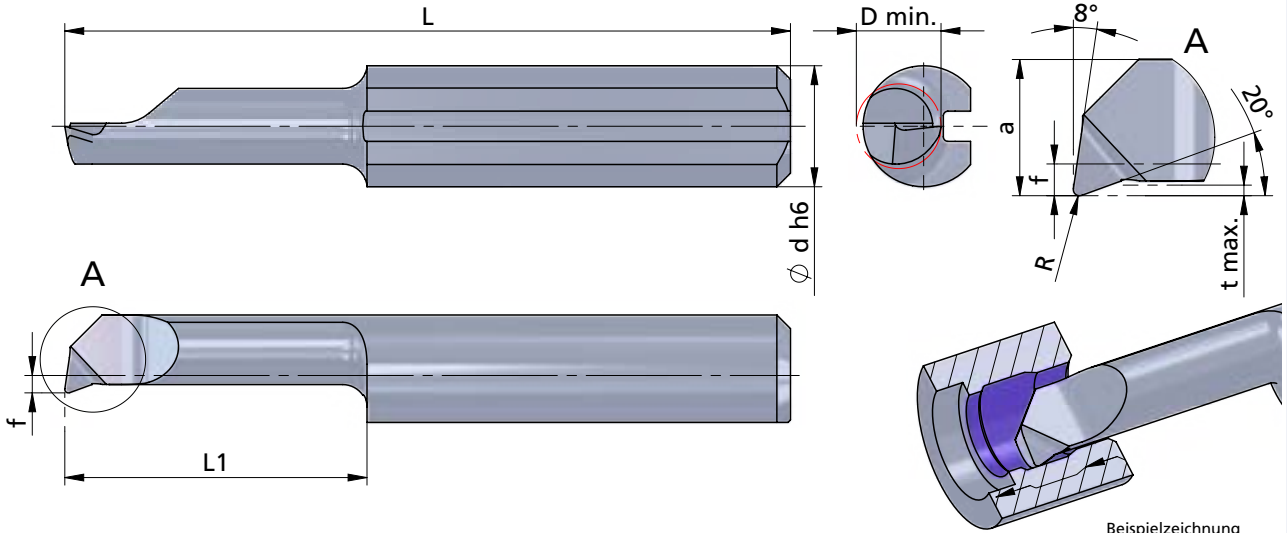

Beispielzeichnung
exemplary application

Rechts (R): wie gezeichnet
Links (L): spiegelbildlich

righthand (R): as shown
lefthand version (L): mirror image

Abmessungen in mm

dimensions in mm

Bestellnummer part number	R	f	a	L	L1	t max.	D min.	Ø d h6	K10F CN45F AL41F PD2F	Klemmhalter Typ toolholder type
R/L 050.6-15	0.15	2.3	5.3	30	15	0.5	6.0	6.0	● ● ●	676...
R/L 050.6-22	0.15	2.3	5.3	37	22	0.5	6.0	6.0	● ● ●	
R/L 050.6-25	0.15	2.3	5.3	40	25	0.5	6.0	6.0	● ● ●	
R/L 050.6-30	0.15	2.3	5.3	45	30	0.5	6.0	6.0	● ● ●	
R/L 050.6-35	0.15	2.3	5.3	50	35	0.5	6.0	6.0	● ● ●	
R/L 050.6-42	0.15	2.3	5.3	57	42	0.5	6.0	6.0	● ● ●	
R/L 050.7-20	0.15	2.8	6.3	35	20	0.6	6.8	7.0	● ● ●	676...
R/L 050.7-25	0.15	2.8	6.3	40	25	0.6	6.8	7.0	● ● ●	
R/L 050.7-30	0.15	2.8	6.3	45	30	0.6	6.8	7.0	● ● ●	
R/L 050.7-35	0.15	2.8	6.3	50	35	0.6	6.8	7.0	● ● ●	
R/L 050.7-40	0.15	2.8	6.3	55	40	0.6	6.8	7.0	● ● ●	
R/L 050.7-45	0.15	2.8	6.3	60	45	0.6	6.8	7.0	● ● ●	
R/L 050.7-50	0.15	2.8	6.3	65	50	0.6	6.8	7.0	● ● ●	670... 687... ...7

Weitere HM Sorten können Sie in der Sortenübersicht im Kapitel "Technische Hinweise" und der Preisliste finden.

More carbide grades you can find in the grades summary in the chapter "technical instructions" and in the price list.

ULTRAMINI

Bohrungsbearbeitung
ab $\varnothing 0.2$ mm

grooving, boring and profiling
starting at $\varnothing 0.2$ mm

Typ 050

Ausdrehen und Kopieren

D min. 0.2 - 9.8 mm

boring and profiling

D min. 0.2 - 9.8 mm

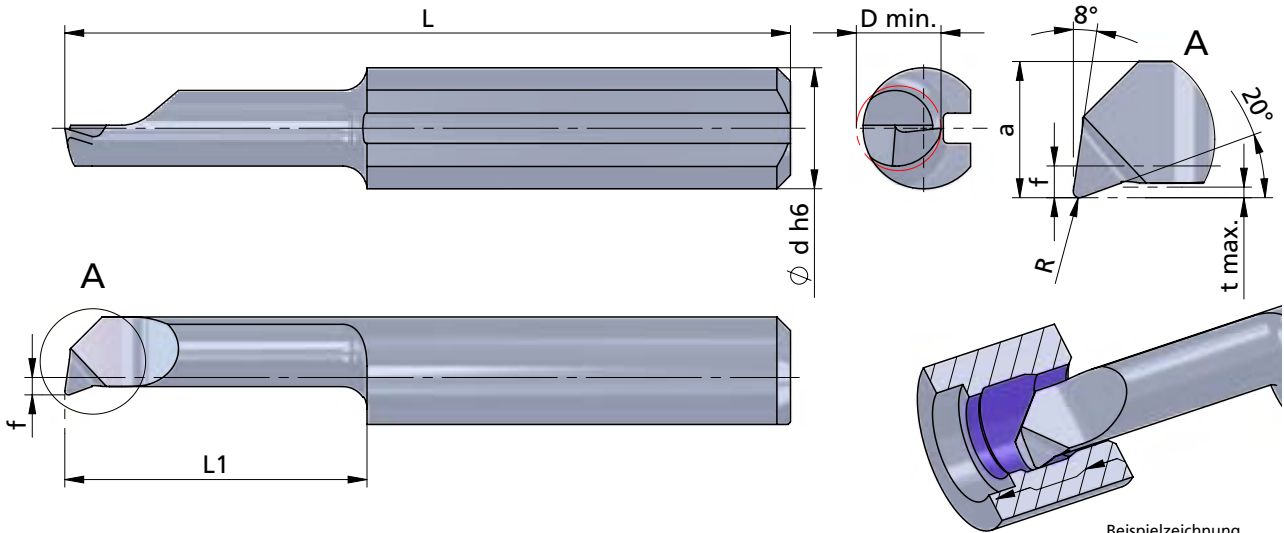

Beispielzeichnung
exemplary application

Rechts (R): wie gezeichnet
Links (L): spiegelbildlich

righthand (R): as shown
lefthand version (L): mirror image

Abmessungen in mm

dimensions in mm

Bestellnummer part number	R	f	a	L	L1	t max.	D min.	\varnothing d h6					Klemmhalter Typ toolholder type	
									K10F	CN45F	AL41F	PD2F		
⋮ ↘														
R/L 050.8-50	0.2	3.3	7.3	70	50	0.7	7.8	8.0			●		681...	680... 687... ...8
R/L 050.8-60	0.2	3.3	7.3	80	60	0.7	7.8	8.0			●		681...	680... 687... ...8
R/L 050.10-35	0.2	4.2	9.2	60	35	1.0	9.8	10.0			●		681...	680... 687... ...8

Weitere HM Sorten können Sie in der Sortenübersicht im Kapitel "Technische Hinweise" und der Preisliste finden.

Bestellbeispiel:
für rechte Ausführung und Sorte
R050.8-50/AL41F

More carbide grades you can find in the grades summary in the chapter "technical instructions" and in the price list.

order-example:
righthand version and grade
R050.8-50/AL41F

ULTRAMINI

Bohrungsbearbeitung
ab $\varnothing 0.2$ mm

grooving, boring and profiling
starting at $\varnothing 0.2$ mm

Typ P50

Audreihen und Kopieren
mit innerer Kühlmittelzufuhr

boring and profiling
with through coolant

Performanceline

D min. 2.0 - 6.8 mm

D min. 2.0 - 6.8 mm

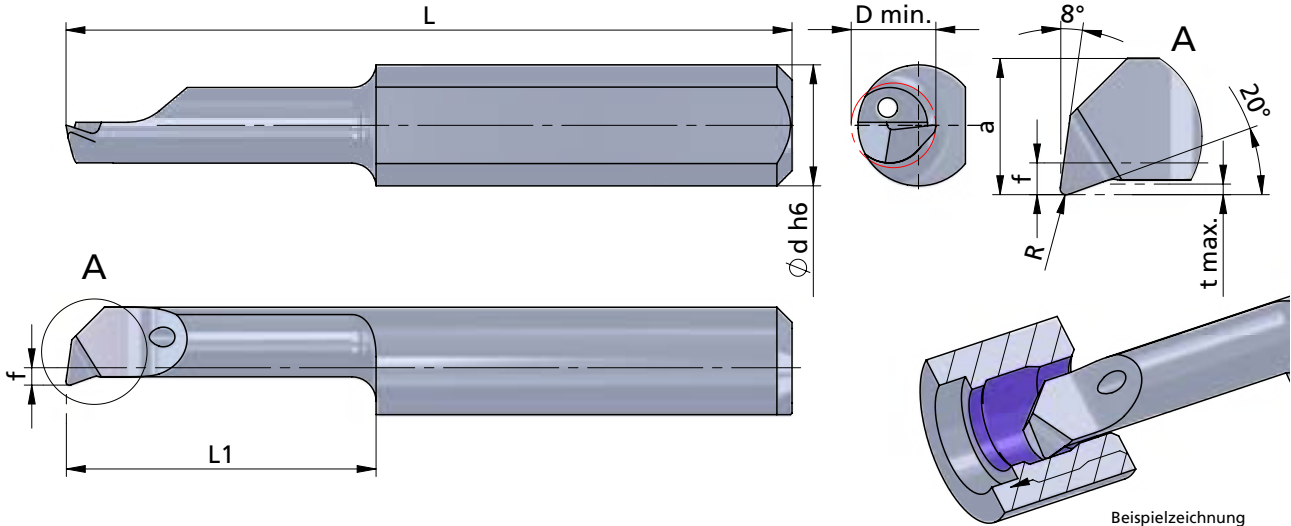

Beispielzeichnung
exemplary application

Rechts (R): wie gezeichnet
Links (L): spiegelbildlich

righthand (R): as shown
lefthand version (L): mirror image



Abmessungen in mm

dimensions in mm

Bestellnummer part number	R	f	a	L	L1	t max.	D min.	Ø d h6	K10F P04C AL41F PD2F	Klemmhalter Typ	toolholder type
										640... 645... ...4	
R/L P50.2-5	0.05	-0.3	1.7	19	5	0.1	2.0	4.0	●		
R/L P50.2-10	0.05	-0.3	1.7	24	10	0.1	2.0	4.0	●		
R/L P50.2-15	0.05	-0.3	1.7	29	15	0.1	2.0	4.0	●		
R/L P50.25-5	0.05	0.2	2.2	19	5	0.15	2.5	4.0	●		
R/L P50.25-10	0.05	0.2	2.2	24	10	0.15	2.5	4.0	●		
R/L P50.25-16	0.05	0.2	2.2	30	16	0.15	2.5	4.0	●		
R/L P50.3-10	0.1	0.6	2.6	24	10	0.2	2.8	4.0	●		
R/L P50.3-16	0.1	0.6	2.6	30	16	0.2	2.8	4.0	●		
R/L P50.3-20	0.1	0.6	2.6	34	20	0.2	2.8	4.0	●		
R/L P50.35-10	0.1	1.1	3.1	24	10	0.25	3.5	4.0	●		
R/L P50.35-16	0.1	1.1	3.1	30	16	0.25	3.5	4.0	●		
R/L P50.35-20	0.1	1.1	3.1	34	20	0.25	3.5	4.0	●		
R/L P50.35-24	0.1	1.1	3.1	38	24	0.25	3.5	4.0	●		
↳ ...											

Weitere HM Sorten können Sie in der Sorten-
übersicht im Kapitel "Technische Hinweise" und
der Preisliste finden.

More carbide grades you can find in the grades
summary in the chapter "technical instructions"
and in the price list.

Bestellbeispiel:
für rechte Ausführung und Sorte
RP50.2-5/P04C

order-example:
righthand version and grade
RP50.2-5/P04C

ULTRAMINI

Bohrungsbearbeitung
ab $\varnothing 0.2$ mm

grooving, boring and profiling
starting at $\varnothing 0.2$ mm

Typ P50

Ausdrehen und Kopieren
mit innerer Kühlmittelzufuhr

boring and profiling
with through coolant

Performanceline

D min. 2.0 - 6.8 mm

D min. 2.0 - 6.8 mm

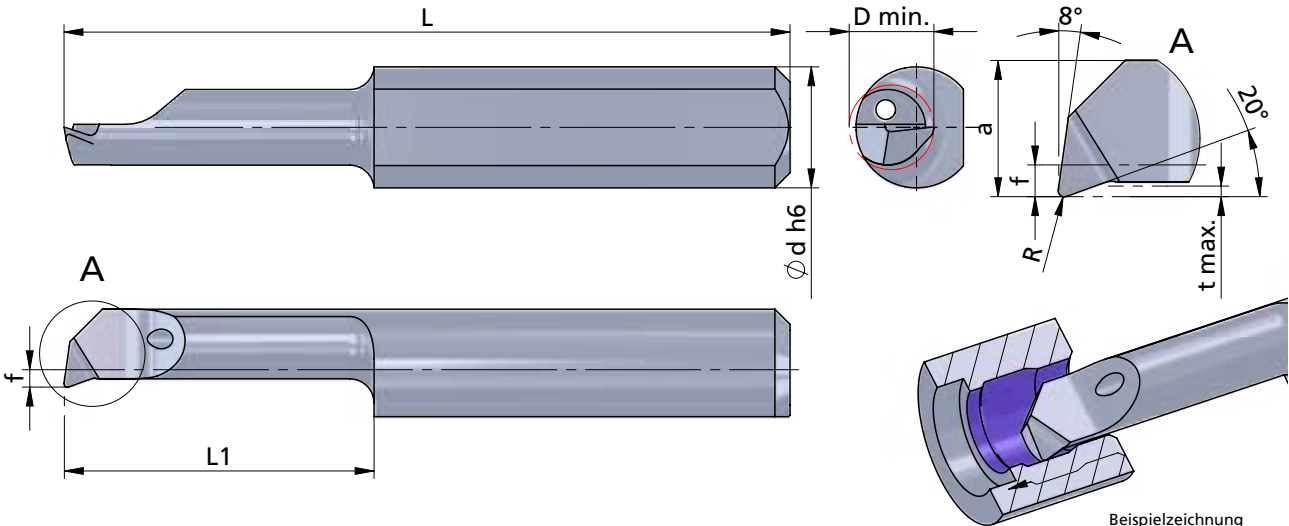

Rechts (R): wie gezeichnet
Links (L): spiegelbildlich

righthand (R): as shown
lefthand version (L): mirror image



Abmessungen in mm

dimensions in mm

Bestellnummer part number	R	f	a	L	L1	t max.	D min.	\varnothing d h6	K10F P04C AL41F PD2F	Klemmhalter Typ toolholder type
R/L P50.4-10	0.1	1.5	3.5	24	10	0.3	4.0	4.0	●	640,4
R/L P50.4-16	0.1	1.5	3.5	30	16	0.3	4.0	4.0	●	
R/L P50.4-20	0.1	1.5	3.5	34	20	0.3	4.0	4.0	●	
R/L P50.4-24	0.1	1.5	3.5	38	24	0.3	4.0	4.0	●	
R/L P50.4-28	0.1	1.5	3.5	42	28	0.3	4.0	4.0	●	
R/L P50.5-10	0.15	1.9	4.4	25	10	0.5	5.0	5.0	●	645, ...
R/L P50.5-15	0.15	1.9	4.4	30	15	0.5	5.0	5.0	●	
R/L P50.5-20	0.15	1.9	4.4	35	20	0.5	5.0	5.0	●	
R/L P50.5-25	0.15	1.9	4.4	40	25	0.5	5.0	5.0	●	
R/L P50.5-30	0.15	1.9	4.4	45	30	0.5	5.0	5.0	●	
R/L P50.5-35	0.15	1.9	4.4	50	35	0.5	5.0	5.0	●	
R/L P50.5-40	0.15	1.9	4.4	55	40	0.5	5.0	5.0	●	
↳ ...										

Weitere HM Sorten können Sie in der Sortenübersicht im Kapitel "Technische Hinweise" und der Preisliste finden.

Bestellbeispiel:
für rechte Ausführung und Sorte
RP50.4-10/P04C

More carbide grades you can find in the grades summary in the chapter "technical instructions" and in the price list.

order-example:
righthand version and grade
RP50.4-10/P04C

ULTRAMINI

Bohrungsbearbeitung
ab \varnothing 0.2 mm

grooving, boring and profiling
starting at \varnothing 0.2 mm

Typ P50

Ausdrehen und Kopieren
mit innerer Kühlmittelzufuhr

boring and profiling
with through coolant

Performanceline

D min. 2.0 - 6.8 mm

D min. 2.0 - 6.8 mm

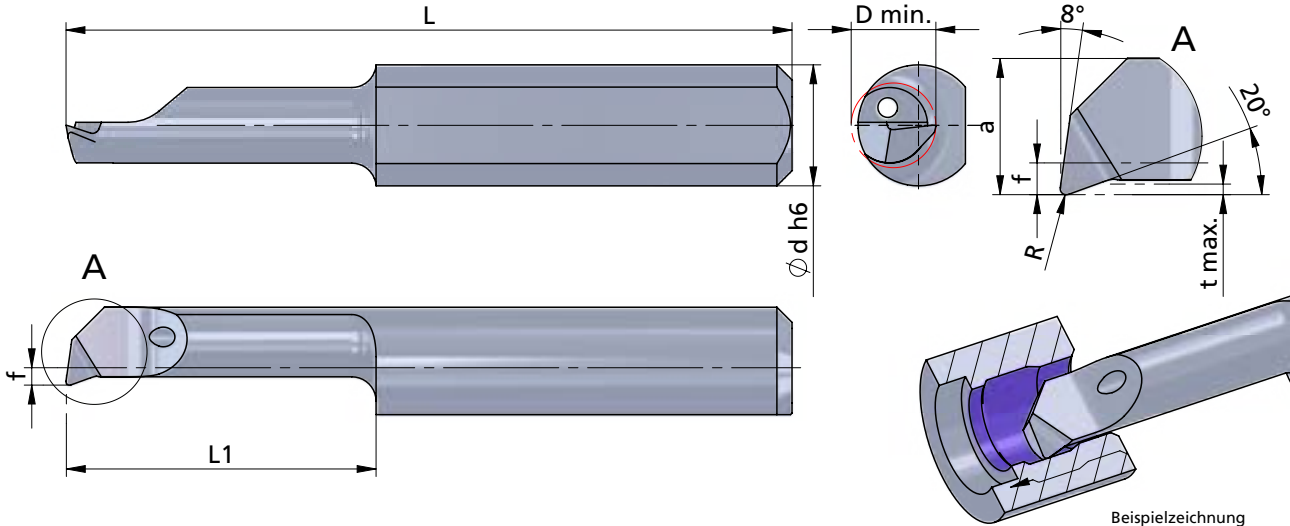

Beispielzeichnung
exemplary application

Rechts (R): wie gezeichnet
Links (L): spiegelbildlich

righthand (R): as shown
lefthand version (L): mirror image

Abmessungen in mm

dimensions in mm



Bestellnummer
part number

R

f

a

L

L1

t max.

D min.

\varnothing d h6

K10F

P04C

AL41F

PD2F

Klemmhalter Typ

toolholder type

... ↘

R/L P50.6-15
R/L P50.6-22
R/L P50.6-25
R/L P50.6-30
R/L P50.6-35
R/L P50.6-42
R/L P50.7-20
R/L P50.7-25
R/L P50.7-30
R/L P50.7-35
R/L P50.7-40
R/L P50.7-45
R/L P50.7-50

0.15
0.15
0.15
0.15
0.15
0.15
0.15
0.15
0.15
0.15
0.15
0.15
0.15
0.15
0.15

2.3
2.3
2.3
2.3
2.3
2.3
2.8
2.8
2.8
2.8
2.8
2.8
2.8
2.8

5.3
5.3
5.3
5.3
5.3
5.3
6.3
6.3
6.3
6.3
6.3
6.3
6.3
6.3

30
37
40
45
50
57
35
40
45
50
55
60
65

15
22
25
30
35
42
20
25
30
35
40
45
50

0.5
0.5
0.5
0.5
0.5
0.5
0.6
0.6
0.6
0.6
0.6
0.6
0.6
0.6

6.0
6.0
6.0
6.0
6.0
6.0
6.8
6.8
6.8
6.8
6.8
6.8
6.8
6.8

6.0
6.0
6.0
6.0
6.0
6.0
7.0
7.0
7.0
7.0
7.0
7.0
7.0
7.0

●
●
●
●
●
●
●
●
●
●
●
●
●
●

676...
676...
676...
676...
676...
676...
676...
676...
676...
676...
676...
676...
676...
676...

660...
660...
660...
660...
660...
660...
670...
670...
670...
670...
670...
670...
670...
670...

...6
...6
...6
...6
...6
...6
...7
...7
...7
...7
...7
...7
...7
...7

Weitere HM Sorten können Sie in der Sortenübersicht im Kapitel "Technische Hinweise" und der Preisliste finden.

More carbide grades you can find in the grades summary in the chapter "technical instructions" and in the price list.

ULTRAMINI

Bohrungsbearbeitung
ab \varnothing 0.2 mm

grooving, boring and profiling
starting at \varnothing 0.2 mm

Typ F050

Ausdrehen für
perfekte Oberflächen

boring for
perfect surface quality

Superfinish

D min. 4.0 - 6.8 mm

D min. 4.0 - 6.8 mm

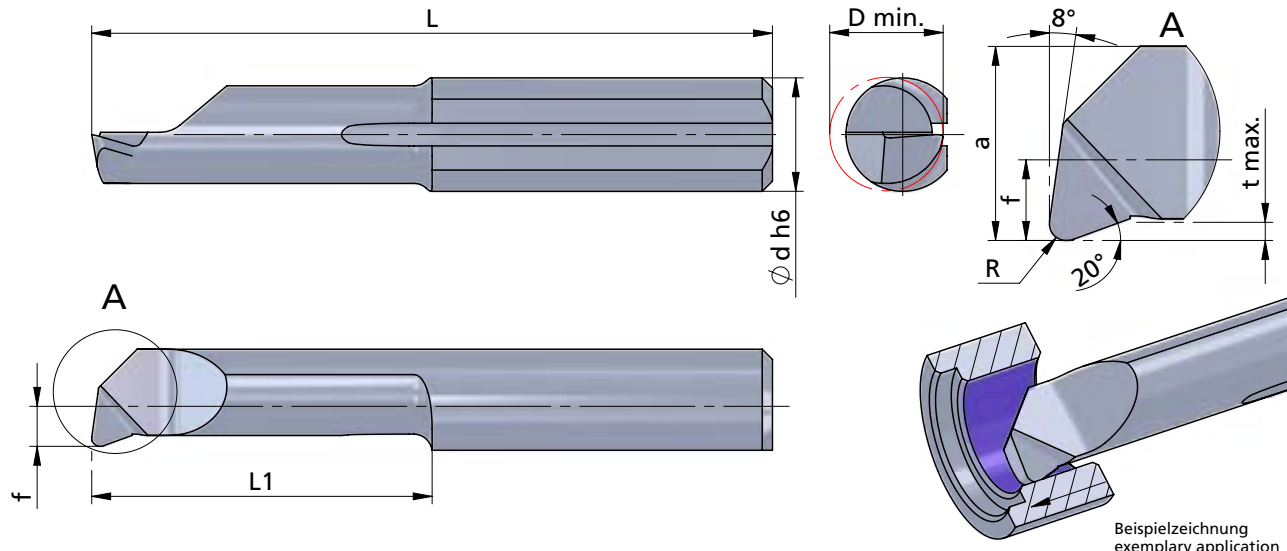

Rechts (R): wie gezeichnet
Links (L): spiegelbildlich

righthand (R): as shown
lefthand version (L): mirror image

Abmessungen in mm

dimensions in mm

Bestellnummer part number	R	f	a	L	L1	t max.	D min.	Ø d h6	Klemmhalter Typ				Klemmhalter Typ	toolholder type
									K10F	CN45F	AL41F	P18C-NH		
R/L F050.4-10	0.4	1.35	3.35	24	10	0.25	4.0	4.0				●		
R/L F050.4-20	0.4	1.35	3.35	34	20	0.25	4.0	4.0				●	645, ...	640,4
R/L F050.5-15	0.4	1.80	4.30	30	15	0.40	5.0	5.0				●	645, ...	650,5
R/L F050.5-25	0.4	1.80	4.30	40	25	0.40	5.0	5.0				●	645, ...	650,5
R/L F050.6-15	0.4	2.20	5.20	30	15	0.50	6.0	6.0				●	676, ...	660,6
R/L F050.6-30	0.4	2.20	5.20	45	30	0.50	6.0	6.0				●	676, ...	660,6
R/L F050.7-20	0.4	2.70	6.20	35	20	0.50	6.8	7.0				●	676, ...	670, ... 687,7
R/L F050.7-35	0.4	2.70	6.20	50	35	0.50	6.8	7.0				●	676, ...	670, ... 687,7

Weitere HM Sorten können Sie in der Sortenübersicht im Kapitel "Technische Hinweise" und der Preisliste finden.

Bestellbeispiel:
für rechte Ausführung und Sorte
RF050.4-10/P18C-NH

weitere Informationen:

- siehe Allgemeine Beschreibung

more informations:

- look at the general instructions

More carbide grades you can find in the grades summary in the chapter "technical instructions" and in the price list.

order-example:
righthand version and grade
RF050.4-10/P18C-NH

ULTRAMINI

Bohrungsbearbeitung
ab \varnothing 0.2 mm

grooving, boring and profiling
starting at \varnothing 0.2 mm

Typ 050.20

Audreihen und Kopieren
mit Geometrie $20^\circ / 20^\circ$

boring and profiling
with geometry $20^\circ / 20^\circ$

D min. 2.0 - 5.0 mm

D min. 2.0 - 5.0 mm

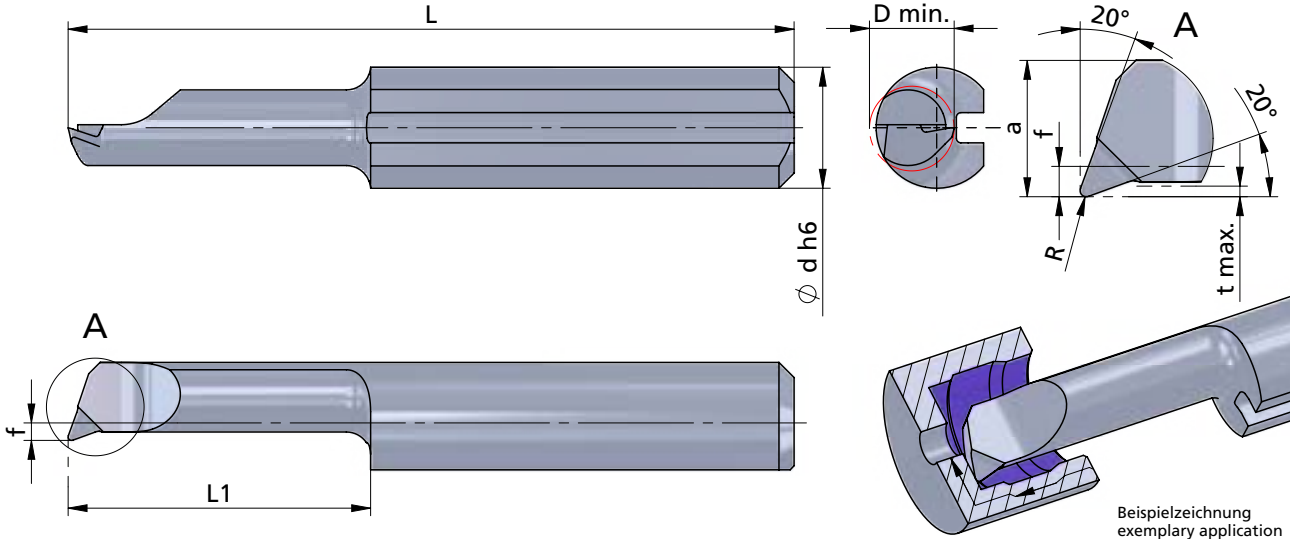
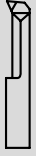

Rechts (R): wie gezeichnet
Links (L): spiegelbildlich

righthand (R): as shown
lefthand version (L): mirror image

Abmessungen in mm

dimensions in mm

Bestellnummer part number	R	f	a	L	L1	t max.	D min.	\varnothing d h6	K10F CN45F AL41F PD2F	Klemmhalter Typ	toolholder type
										645,...	640... ...4
R/L 050.20.2-5	0.05	-0.3	1.7	19	5	0.1	2.0	4.0		645,...	640... ...4
R/L 050.20.2-10	0.05	-0.3	1.7	24	10	0.1	2.0	4.0			
R/L 050.20.2-15	0.05	-0.3	1.7	29	15	0.1	2.0	4.0			
R/L 050.20.3-10	0.1	0.6	2.6	24	10	0.2	2.8	4.0			
R/L 050.20.3-16	0.1	0.6	2.6	30	16	0.2	2.8	4.0			
R/L 050.20.3-20	0.1	0.6	2.6	34	20	0.2	2.8	4.0			
R/L 050.20.4-10	0.1	1.5	3.5	24	10	0.3	4.0	4.0			
R/L 050.20.4-16	0.1	1.5	3.5	30	16	0.3	4.0	4.0			
R/L 050.20.4-20	0.1	1.5	3.5	34	20	0.3	4.0	4.0			
R/L 050.20.4-24	0.1	1.5	3.5	38	24	0.3	4.0	4.0			
R/L 050.20.4-28	0.1	1.5	3.5	42	28	0.3	4.0	4.0			
R/L 050.20.5-10	0.15	1.9	4.4	25	10	0.5	5.0	5.0		650... ...5	
R/L 050.20.5-20	0.15	1.9	4.4	35	20	0.5	5.0	5.0			
R/L 050.20.5-35	0.15	1.9	4.4	50	35	0.5	5.0	5.0			

Weitere HM Sorten können Sie in der Sortenübersicht im Kapitel "Technische Hinweise" und der Preisliste finden.

More carbide grades you can find in the grades summary in the chapter "technical instructions" and in the price list.

Bestellbeispiel:
für rechte Ausführung und Sorte
R050.20.2-5/AL41F

order-example:
righthand version and grade
R050.20.2-5/AL41F

ULTRAMINI

Bohrungsbearbeitung
ab \varnothing 0.2 mm

grooving, boring and profiling
starting at \varnothing 0.2 mm

Typ P50.20

Audreihen und Kopieren
mit Geometrie $20^\circ / 20^\circ$
und innerer Kühlmittelzufuhr

boring and profiling
with geometry $20^\circ / 20^\circ$
and through coolant

Performanceline

D min. 2.0 - 5.0 mm

D min. 2.0 - 5.0 mm

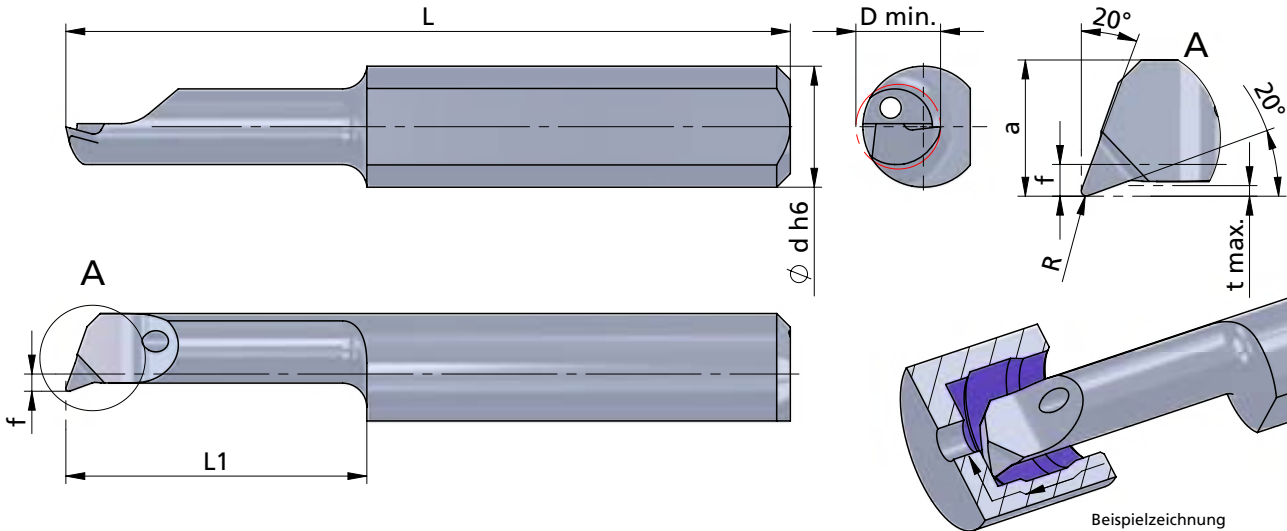

Beispielzeichnung
exemplary application

Rechts (R): wie gezeichnet
Links (L): spiegelbildlich

righthand (R): as shown
lefthand version (L): mirror image



Abmessungen in mm

dimensions in mm

Bestellnummer part number	R	f	a	L	L1	t max.	D min.	Ø d h6	K10F P04C AL41F PD2F	Klemmhalter Typ	toolholder type
										645,...	6404
R/L P50.20.2-5	0.05	-0.3	1.7	19	5	0.1	2.0	4.0	●	645,...	6404
R/L P50.20.2-10	0.05	-0.3	1.7	24	10	0.1	2.0	4.0	●		
R/L P50.20.2-15	0.05	-0.3	1.7	29	15	0.1	2.0	4.0	●		
R/L P50.20.3-10	0.1	0.6	2.6	24	10	0.2	2.8	4.0	●		
R/L P50.20.3-16	0.1	0.6	2.6	30	16	0.2	2.8	4.0	●		
R/L P50.20.3-20	0.1	0.6	2.6	34	20	0.2	2.8	4.0	●		
R/L P50.20.4-10	0.1	1.5	3.5	24	10	0.3	4.0	4.0	●		
R/L P50.20.4-16	0.1	1.5	3.5	30	16	0.3	4.0	4.0	●		
R/L P50.20.4-20	0.1	1.5	3.5	34	20	0.3	4.0	4.0	●		
R/L P50.20.4-24	0.1	1.5	3.5	38	24	0.3	4.0	4.0	●		
R/L P50.20.4-28	0.1	1.5	3.5	42	28	0.3	4.0	4.0	●		
R/L P50.20.5-10	0.15	1.9	4.4	25	10	0.5	5.0	5.0	●	6505	
R/L P50.20.5-20	0.15	1.9	4.4	35	20	0.5	5.0	5.0	●		
R/L P50.20.5-35	0.15	1.9	4.4	50	35	0.5	5.0	5.0	●		

Weitere HM Sorten können Sie in der Sortenübersicht im Kapitel "Technische Hinweise" und der Preisliste finden.

Bestellbeispiel:
für rechte Ausführung und Sorte
RP50.20.2-5/P04C

More carbide grades you can find in the grades summary in the chapter "technical instructions" and in the price list.

order-example:
righthand version and grade
RP50.20.2-5/P04C

ULTRAMINI

Bohrungsbearbeitung
ab $\varnothing 0.2$ mm

grooving, boring and profiling
starting at $\varnothing 0.2$ mm

Typ 053

Audreihen und Kopieren
mit Eckenradius 0.03 mm

boring and profiling
with corner radius 0.03 mm

D min. 2.8 - 4.0 mm

D min. 2.8 - 4.0 mm

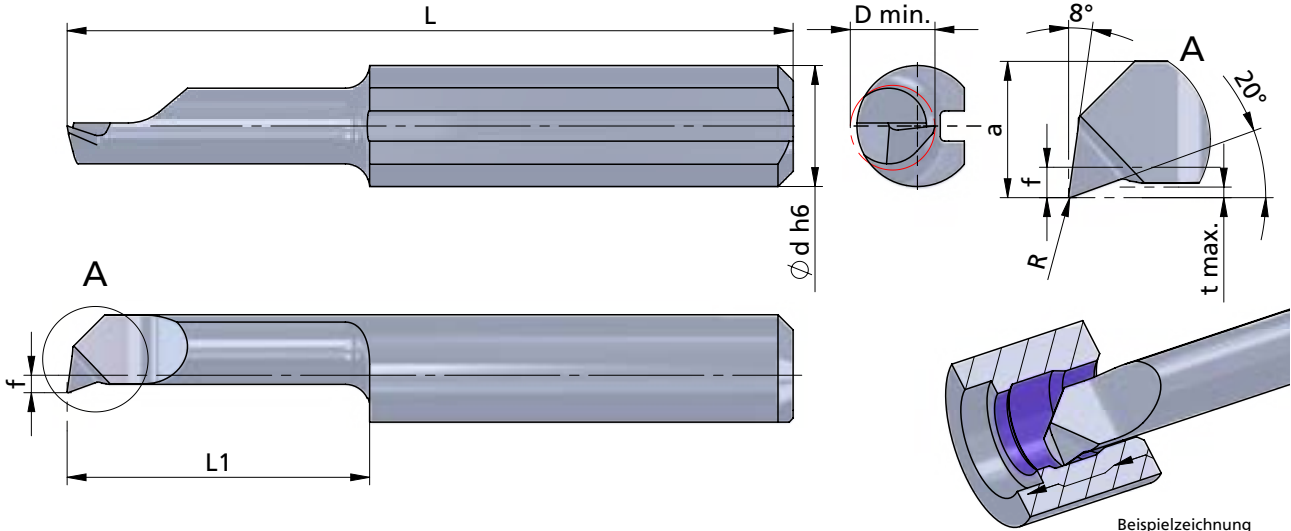

Rechts (R): wie gezeichnet
Links (L): spiegelbildlich

righthand (R): as shown
lefthand version (L): mirror image

Abmessungen in mm

dimensions in mm

Bestellnummer part number	R	f	a	L	L1	t max.	D min.	Ø d h6	Klemmhalter Typ toolholder type				
									K10F	CN45F	AL41F	PD2F	
R/L 053.3-10	0.03	0.6	2.6	24	10	0.2	2.8	4.0			●		
R/L 053.3-16	0.03	0.6	2.6	30	16	0.2	2.8	4.0			●		
R/L 053.3-20	0.03	0.6	2.6	34	20	0.2	2.8	4.0			●		
R/L 053.4-10	0.03	1.5	3.5	24	10	0.3	4.0	4.0			●		640... 645... ...4
R/L 053.4-16	0.03	1.5	3.5	30	16	0.3	4.0	4.0			●		
R/L 053.4-20	0.03	1.5	3.5	34	20	0.3	4.0	4.0			●		
R/L 053.4-24	0.03	1.5	3.5	38	24	0.3	4.0	4.0			●		
R/L 053.4-28	0.03	1.5	3.5	42	28	0.3	4.0	4.0			●		

Weitere HM Sorten können Sie in der Sortenübersicht im Kapitel "Technische Hinweise" und der Preisliste finden.

More carbide grades you can find in the grades summary in the chapter "technical instructions" and in the price list.

ULTRAMINI

Bohrungsbearbeitung
ab \varnothing 0.2 mm

grooving, boring and profiling
starting at \varnothing 0.2 mm

Typ P53

Ausdrehen und Kopieren
mit Eckenradius 0.03 mm
und innerer Kühlmittelzufuhr

boring and profiling
with corner radius 0.03 mm
and through coolant

Performanceline

D min. 2.8 - 4.0 mm

D min. 2.8 - 4.0 mm

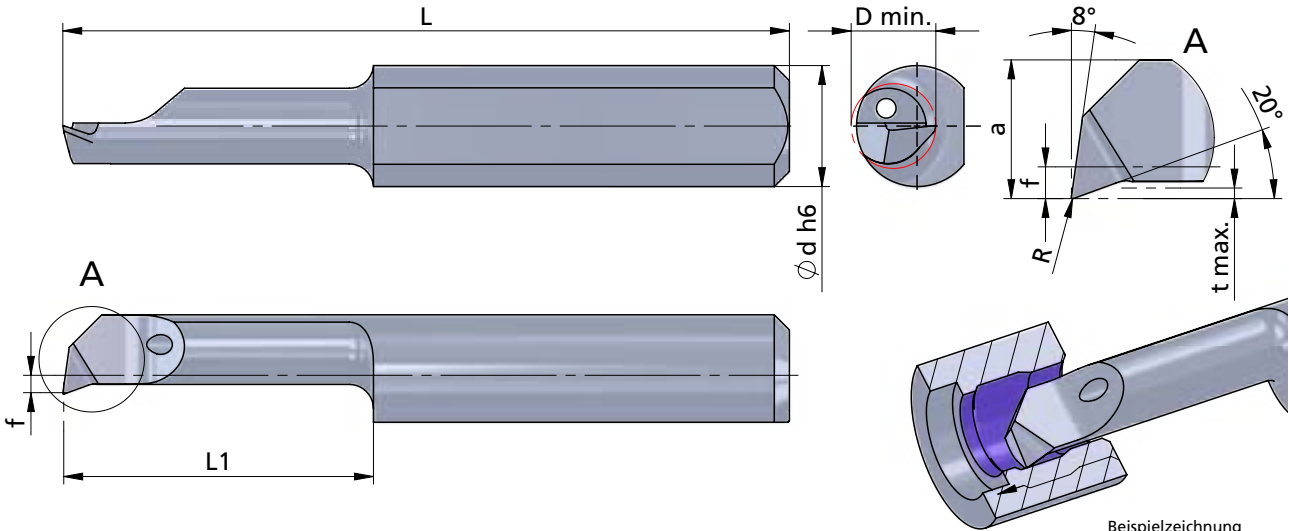

Rechts (R): wie gezeichnet
Links (L): spiegelbildlich

righthand (R): as shown
lefthand version (L): mirror image



Abmessungen in mm

dimensions in mm

Bestellnummer part number	R	f	a	L	L1	t max.	D min.	\varnothing d h6					Klemmhalter Typ toolholder type
									K10F	P04C	AL41F	PD2F	
R/L P53.3-10	0.03	0.6	2.6	24	10	0.2	2.8	4.0		●			640... 645... ...4
R/L P53.3-16	0.03	0.6	2.6	30	16	0.2	2.8	4.0		●			
R/L P53.3-20	0.03	0.6	2.6	34	20	0.2	2.8	4.0		●			
R/L P53.4-10	0.03	1.5	3.5	24	10	0.3	4.0	4.0		●			
R/L P53.4-16	0.03	1.5	3.5	30	16	0.3	4.0	4.0		●			
R/L P53.4-20	0.03	1.5	3.5	34	20	0.3	4.0	4.0		●			
R/L P53.4-24	0.03	1.5	3.5	38	24	0.3	4.0	4.0		●			
R/L P53.4-28	0.03	1.5	3.5	42	28	0.3	4.0	4.0		●			

Weitere HM Sorten können Sie in der Sortenübersicht im Kapitel "Technische Hinweise" und der Preisliste finden.

Bestellbeispiel:
für rechte Ausführung und Sorte
RP53.3-10/P04C

More carbide grades you can find in the grades summary in the chapter "technical instructions" and in the price list.

order-example:
righthand version and grade
RP53.3-10/P04C

ULTRAMINI

Bohrungsbearbeitung
ab $\varnothing 0.2$ mm

grooving, boring and profiling
starting at $\varnothing 0.2$ mm

Typ 055

Ausdrehen und Kopieren
mit Eckenradius 0.05 mm

boring and profiling
with corner radius 0.05 mm

D min. 2.0 - 6.0 mm

D min. 2.0 - 6.0 mm

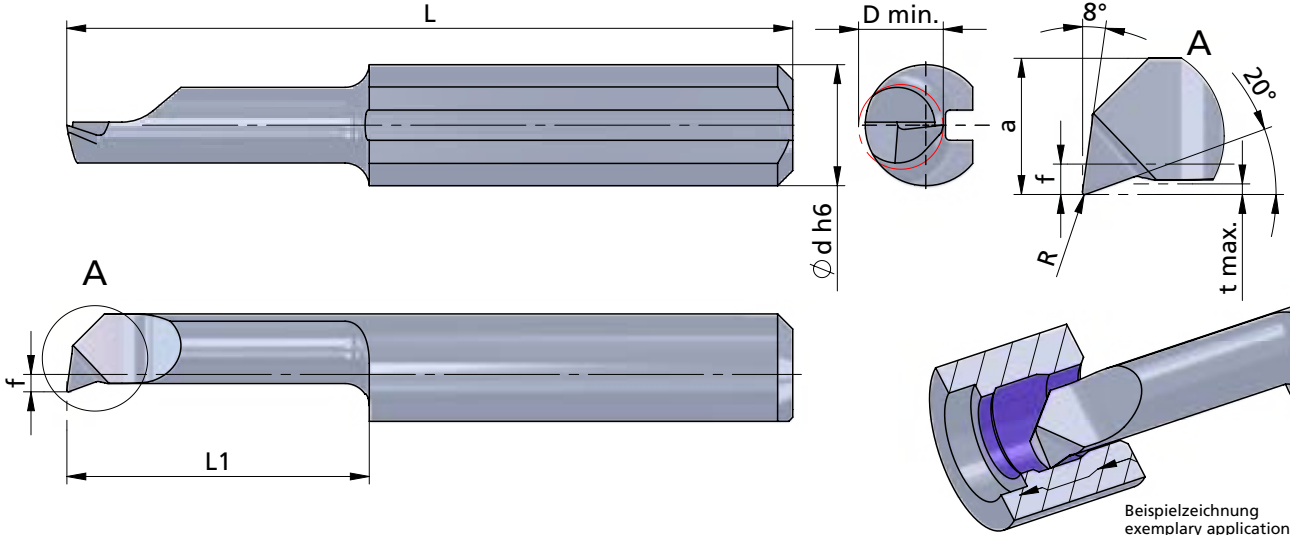

Beispielzeichnung
exemplary application

Rechts (R): wie gezeichnet
Links (L): spiegelbildlich

righthand (R): as shown
lefthand version (L): mirror image

Abmessungen in mm

dimensions in mm

Bestellnummer part number	R	f	a	L	L1	t max.	D min.	Ø d h6	K10F	CN45F	AL41F	PD2F	Klemmhalter Typ	toolholder type
													640... 645... ...4	
R/L 055.2-5	0.05	-0.3	1.7	19	5	0.1	2.0	4.0			●			
R/L 055.2-10	0.05	-0.3	1.7	24	10	0.1	2.0	4.0			●			
R/L 055.2-15	0.05	-0.3	1.7	29	15	0.1	2.0	4.0			●			
R/L 055.3-10	0.05	0.6	2.6	24	10	0.2	2.8	4.0			●			
R/L 055.3-16	0.05	0.6	2.6	30	16	0.2	2.8	4.0			●			
R/L 055.3-20	0.05	0.6	2.6	34	20	0.2	2.8	4.0			●			
R/L 055.4-10	0.05	1.5	3.5	24	10	0.3	4.0	4.0			●			
R/L 055.4-16	0.05	1.5	3.5	30	16	0.3	4.0	4.0			●			
R/L 055.4-20	0.05	1.5	3.5	34	20	0.3	4.0	4.0			●			
R/L 055.4-24	0.05	1.5	3.5	38	24	0.3	4.0	4.0			●			
R/L 055.4-28	0.05	1.5	3.5	42	28	0.3	4.0	4.0			●			
↳ ...														

Weitere HM Sorten können Sie in der Sortenübersicht im Kapitel "Technische Hinweise" und der Preisliste finden.

More carbide grades you can find in the grades summary in the chapter "technical instructions" and in the price list.

ULTRAMINI

Bohrungsbearbeitung
ab \varnothing 0.2 mm

grooving, boring and profiling
starting at \varnothing 0.2 mm

Typ 055

Ausdrehen und Kopieren
mit Eckenradius 0.05 mm

boring and profiling
with corner radius 0.05 mm

D min. 2.0 - 6.0 mm

D min. 2.0 - 6.0 mm

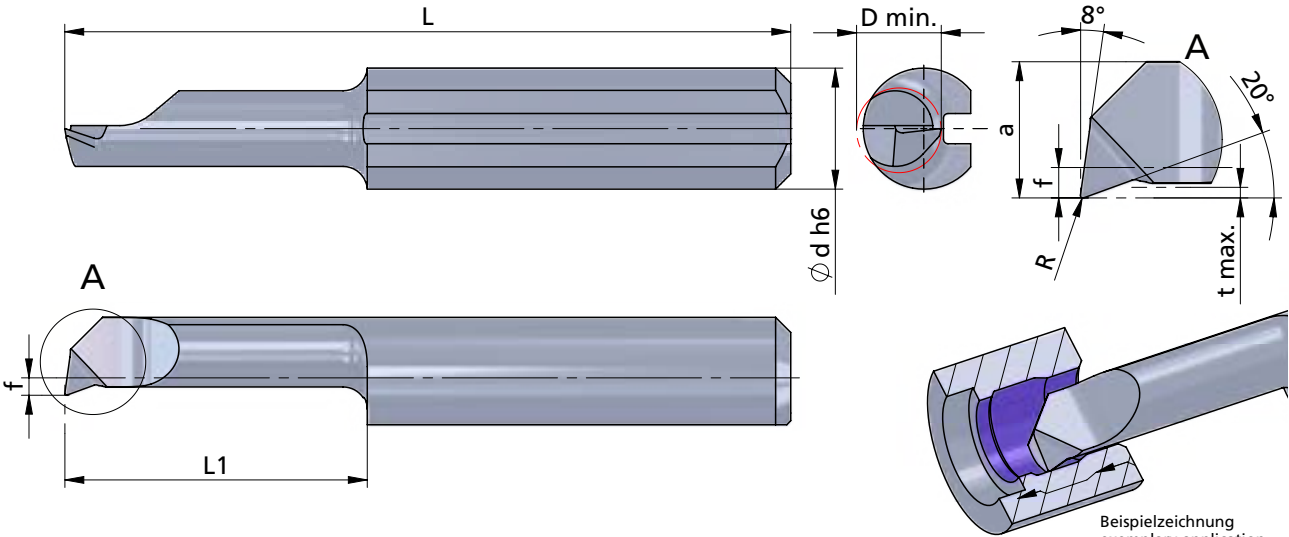

Beispielzeichnung
exemplary application

Rechts (R): wie gezeichnet
Links (L): spiegelbildlich

righthand (R): as shown
lefthand version (L): mirror image

Abmessungen in mm

dimensions in mm

Bestellnummer part number	R	f	a	L	L1	t max.	D min.	Ø d h6	K10F CN45F AL41F PD2F	Klemmhalter Typ	toolholder type
...											
R/L 055.5-10	0.05	1.9	4.4	25	10	0.5	5.0	5.0		●	
R/L 055.5-15	0.05	1.9	4.4	30	15	0.5	5.0	5.0		●	
R/L 055.5-20	0.05	1.9	4.4	35	20	0.5	5.0	5.0		●	645... 650... ...5
R/L 055.5-25	0.05	1.9	4.4	40	25	0.5	5.0	5.0		●	
R/L 055.5-30	0.05	1.9	4.4	45	30	0.5	5.0	5.0		●	
R/L 055.5-35	0.05	1.9	4.4	50	35	0.5	5.0	5.0		●	
R/L 055.6-15	0.05	2.3	5.3	30	15	0.5	6.0	6.0		●	
R/L 055.6-22	0.05	2.3	5.3	37	22	0.5	6.0	6.0		●	
R/L 055.6-25	0.05	2.3	5.3	40	25	0.5	6.0	6.0		●	660... 676... ...6
R/L 055.6-30	0.05	2.3	5.3	45	30	0.5	6.0	6.0		●	
R/L 055.6-35	0.05	2.3	5.3	50	35	0.5	6.0	6.0		●	
R/L 055.6-42	0.05	2.3	5.3	57	42	0.5	6.0	6.0		●	

Weitere HM Sorten können Sie in der Sortenübersicht im Kapitel "Technische Hinweise" und der Preisliste finden.

Bestellbeispiel:
für rechte Ausführung und Sorte
R055.5-10/AL41F

More carbide grades you can find in the grades summary in the chapter "technical instructions" and in the price list.

order-example:
righthand version and grade
R055.5-10/AL41F

ULTRAMINI

Bohrungsbearbeitung
ab $\varnothing 0.2$ mm

grooving, boring and profiling
starting at $\varnothing 0.2$ mm

Typ P55

Ausdrehen und Kopieren
mit Eckenradius 0.05 mm
und innerer Kühlmittelzufuhr

boring and profiling
with corner radius 0.05 mm
and through coolant

Performanceline

D min. 2.0 - 6.0 mm

D min. 2.0 - 6.0 mm

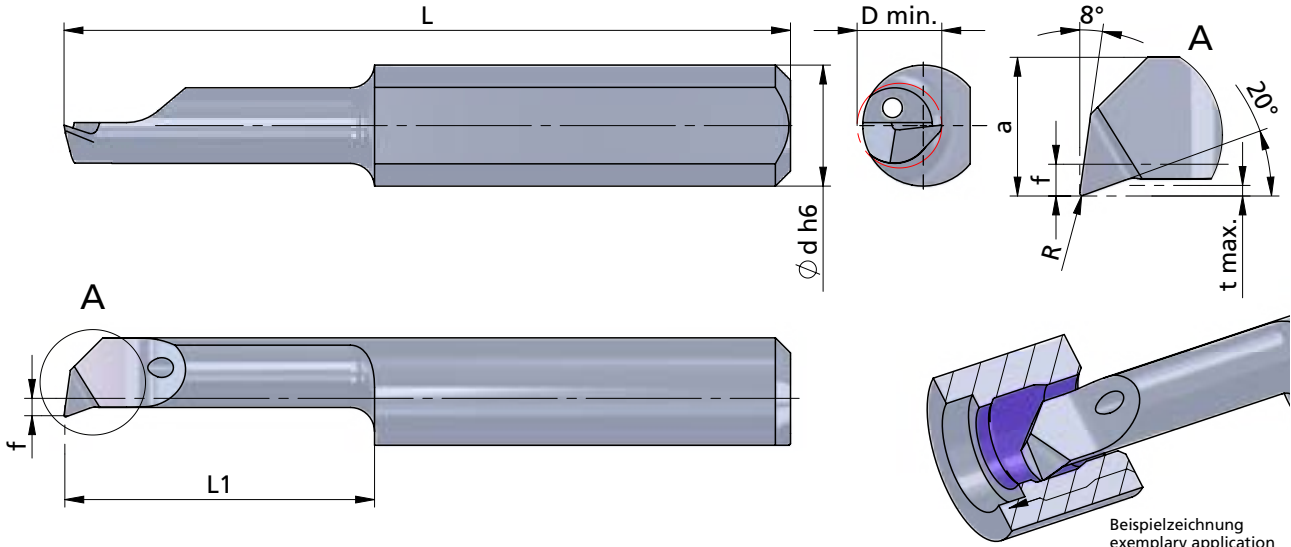
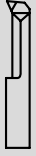

Beispielzeichnung
exemplary application

Rechts (R): wie gezeichnet
Links (L): spiegelbildlich

righthand (R): as shown
lefthand version (L): mirror image

Abmessungen in mm

dimensions in mm



Bestellnummer part number	R	f	a	L	L1	t max.	D min.	Ø d h6	K10F P04C AL41F PD2F	Klemmhalter Typ	toolholder type
R/L P55.2-5	0.05	-0.3	1.7	19	5	0.1	2.0	4.0	●	640... 645... ...4	
R/L P55.2-10	0.05	-0.3	1.7	24	10	0.1	2.0	4.0	●		
R/L P55.2-15	0.05	-0.3	1.7	29	15	0.1	2.0	4.0	●		
R/L P55.3-10	0.05	0.6	2.6	24	10	0.2	2.8	4.0	●		
R/L P55.3-16	0.05	0.6	2.6	30	16	0.2	2.8	4.0	●		
R/L P55.3-20	0.05	0.6	2.6	34	20	0.2	2.8	4.0	●		
R/L P55.4-10	0.05	1.5	3.5	24	10	0.3	4.0	4.0	●		
R/L P55.4-16	0.05	1.5	3.5	30	16	0.3	4.0	4.0	●		
R/L P55.4-20	0.05	1.5	3.5	34	20	0.3	4.0	4.0	●		
R/L P55.4-24	0.05	1.5	3.5	38	24	0.3	4.0	4.0	●		
R/L P55.4-28	0.05	1.5	3.5	42	28	0.3	4.0	4.0	●		
↳ ...											

Weitere HM Sorten können Sie in der Sorten-
übersicht im Kapitel "Technische Hinweise" und
der Preisliste finden.

More carbide grades you can find in the grades
summary in the chapter "technical instructions"
and in the price list.

ULTRAMINI

Bohrungsbearbeitung
ab $\varnothing 0.2$ mm

grooving, boring and profiling
starting at $\varnothing 0.2$ mm

Typ P55

Ausdrehen und Kopieren
mit Eckenradius 0.05 mm
und innerer Kühlmittelzufuhr

boring and profiling
with corner radius 0.05 mm
and through coolant

Performanceline

D min. 2.0 - 6.0 mm

D min. 2.0 - 6.0 mm

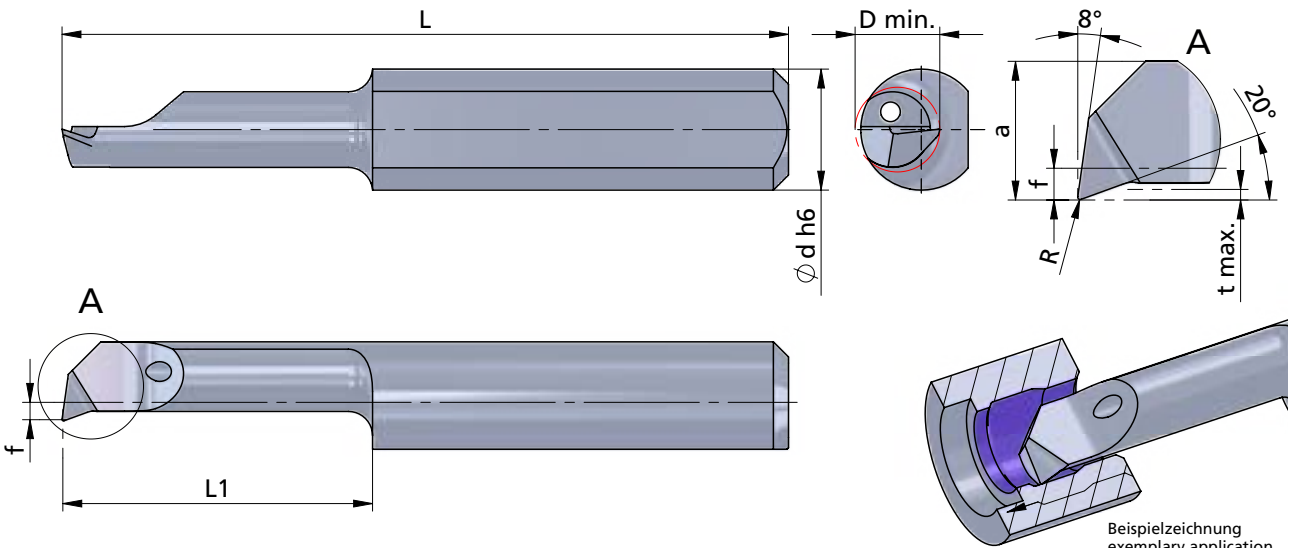

Rechts (R): wie gezeichnet
Links (L): spiegelbildlich

righthand (R): as shown
lefthand version (L): mirror image

Abmessungen in mm

dimensions in mm



Bestellnummer part number	R	f	a	L	L1	t max.	D min.	$\varnothing d h6$	K10F P04C AL41F PD2F	Klemmhalter Typ	toolholder type
...											
R/L P55.5-10	0.05	1.9	4.4	25	10	0.5	5.0	5.0	●		
R/L P55.5-15	0.05	1.9	4.4	30	15	0.5	5.0	5.0	●		
R/L P55.5-20	0.05	1.9	4.4	35	20	0.5	5.0	5.0	●		
R/L P55.5-25	0.05	1.9	4.4	40	25	0.5	5.0	5.0	●		645... 650... ...5
R/L P55.5-30	0.05	1.9	4.4	45	30	0.5	5.0	5.0	●		
R/L P55.5-35	0.05	1.9	4.4	50	35	0.5	5.0	5.0	●		
R/L P55.6-15	0.05	2.3	5.3	30	15	0.5	6.0	6.0	●		
R/L P55.6-22	0.05	2.3	5.3	37	22	0.5	6.0	6.0	●		
R/L P55.6-25	0.05	2.3	5.3	40	25	0.5	6.0	6.0	●		
R/L P55.6-30	0.05	2.3	5.3	45	30	0.5	6.0	6.0	●		
R/L P55.6-35	0.05	2.3	5.3	50	35	0.5	6.0	6.0	●		660... 676... ...6
R/L P55.6-42	0.05	2.3	5.3	57	42	0.5	6.0	6.0	●		

Weitere HM Sorten können Sie in der Sortenübersicht im Kapitel "Technische Hinweise" und der Preisliste finden.

Bestellbeispiel:
für rechte Ausführung und Sorte
RP55.5-10/P04C

More carbide grades you can find in the grades summary in the chapter "technical instructions" and in the price list.

order-example:
righthand version and grade
RP55.5-10/P04C

ULTRAMINI

Bohrungsbearbeitung
ab $\varnothing 0.2$ mm

grooving, boring and profiling
starting at $\varnothing 0.2$ mm

Typ 050...B

Audreihen und Kopieren
mit innerer Kühlmittelzufuhr

boring and profiling
with through coolant

D min. 6.0 - 6.8 mm
Auskrägung (L1) bis 7x D

D min. 6.0 - 6.8 mm
overhang length (L1) up to 7x D

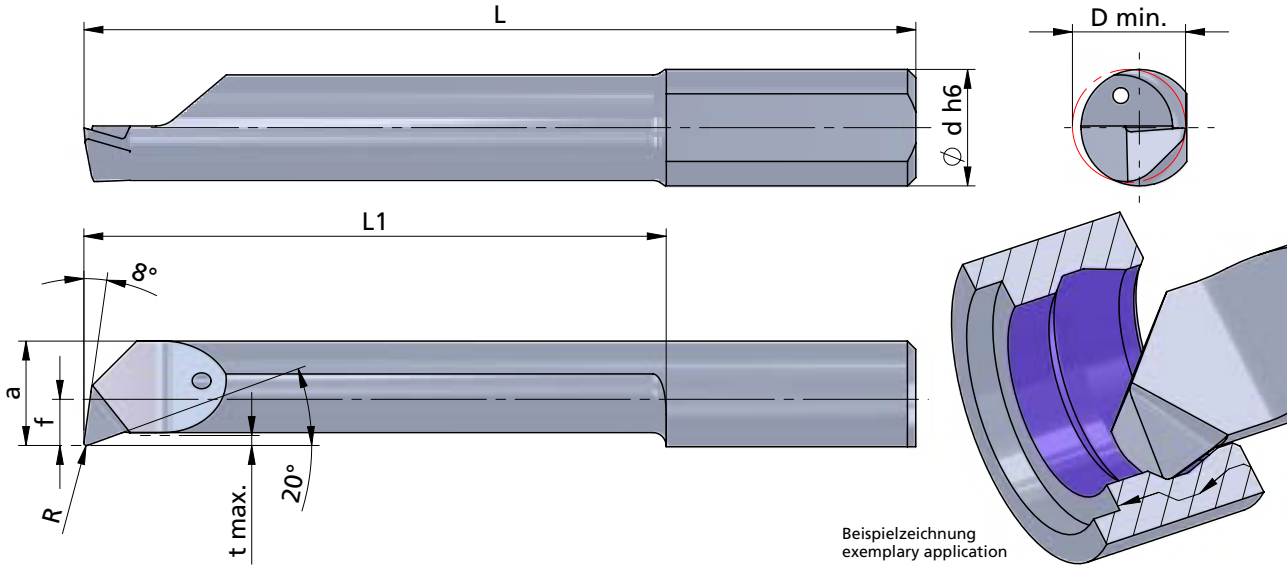
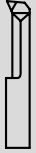

Rechts (R): wie gezeichnet
Links (L): spiegelbildlich

righthand (R): as shown
lefthand version (L): mirror image

Abmessungen in mm

dimensions in mm



Bestellnummer part number	R	f	a	L	L1	t max.	D min.	Ø d h6	K10F CN45F AL41F PD2F	Klemmhalter Typ 676...	toolholder type 660... ...6 670... 687... ...7
R/L 050.6-42B	0.15	2.3	5.3	57	42	0.5	6.0	6.0	●		
R/L 050.7-35B	0.15	2.8	6.3	50	35	0.6	6.8	7.0	●		
R/L 050.7-40B	0.15	2.8	6.3	55	40	0.6	6.8	7.0	●		
R/L 050.7-45B	0.15	2.8	6.3	60	45	0.6	6.8	7.0	●		
R/L 050.7-50B	0.15	2.8	6.3	65	50	0.6	6.8	7.0	●		

Weitere HM Sorten können Sie in der Sortenübersicht im Kapitel "Technische Hinweise" und der Preisliste finden.

More carbide grades you can find in the grades summary in the chapter "technical instructions" and in the price list.

Bestellbeispiel:
für rechte Ausführung und Sorte
R050.6-35B/AL41F

order-example:
righthand version and grade
R050.6-35B/AL41F

ULTRAMINI

Bohrungsbearbeitung
ab \varnothing 0.2 mm

grooving, boring and profiling
starting at \varnothing 0.2 mm

Typ 050...C

Ausdrehen und Kopieren
mit Spantreppe
für bessere Spantkontrolle

boring and profiling
with chipbreaker
for better chipcontrol

D min. 2.0 - 6.8 mm
Auskrägung (L1) bis 7x D

D min. 2.0 - 6.8 mm
overhang length (L1) up to 7x D

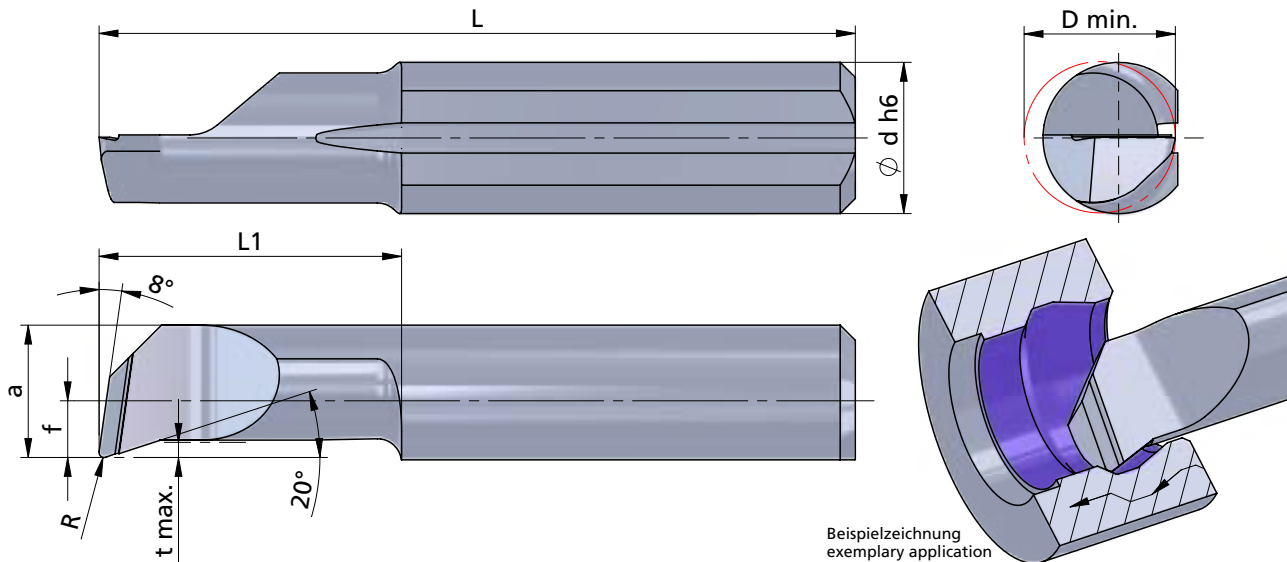

Rechts (R): wie gezeichnet
Links (L): spiegelbildlich

righthand (R): as shown
lefthand version (L): mirror image

Abmessungen in mm

dimensions in mm

Bestellnummer part number	R	f	a	L	L1	t max.	D min.	Ø d h6	K10F CN45F AL41F PD2F	Klemmhalter Typ 645,...	toolholder type 640,4 650,5
R/L 050.2-10C	0.05	-0.3	1.7	24	10	0.1	2.0	4.0	●	645,...	640,4
R/L 050.3-10C	0.1	0.6	2.6	24	10	0.2	2.8	4.0	●		
R/L 050.3-16C	0.1	0.6	2.6	30	16	0.2	2.8	4.0	●		
R/L 050.4-10C	0.1	1.5	3.5	24	10	0.3	4.0	4.0	●		
R/L 050.4-16C	0.1	1.5	3.5	30	16	0.3	4.0	4.0	●		
R/L 050.4-20C	0.1	1.5	3.5	34	20	0.3	4.0	4.0	●		
R/L 050.4-24C	0.1	1.5	3.5	38	24	0.3	4.0	4.0	●		
R/L 050.4-28C	0.1	1.5	3.5	42	28	0.3	4.0	4.0	●		
R/L 050.5-10C	0.15	1.9	4.4	25	10	0.5	5.0	5.0	●	645,...	650,5
R/L 050.5-15C	0.15	1.9	4.4	30	15	0.5	5.0	5.0	● ●		
R/L 050.5-20C	0.15	1.9	4.4	35	20	0.5	5.0	5.0	● ●		
R/L 050.5-25C	0.15	1.9	4.4	40	25	0.5	5.0	5.0	● ●		
R/L 050.5-30C	0.15	1.9	4.4	45	30	0.5	5.0	5.0	● ●		
R/L 050.5-35C	0.15	1.9	4.4	50	35	0.5	5.0	5.0	● ●		
↳ ...											

Weitere HM Sorten können Sie in der Sortenübersicht im Kapitel "Technische Hinweise" und der Preisliste finden.

Bestellbeispiel:
für rechte Ausführung und Sorte
R050.2-10C/AL41F

More carbide grades you can find in the grades summary in the chapter "technical instructions" and in the price list.

order-example:
righthand version and grade
R050.2-10C/AL41F

ULTRAMINI

Bohrungsbearbeitung
ab \varnothing 0.2 mm

grooving, boring and profiling
starting at \varnothing 0.2 mm

Typ 050...C

Ausdrehen und Kopieren
mit Spantreppe
für bessere Spantkontrolle

boring and profiling
with chipbreaker
for better chipcontrol

D min. 2.0 - 6.8 mm
Auskrägung (L1) bis 7x D

D min. 2.0 - 6.8 mm
overhang length (L1) up to 7x D

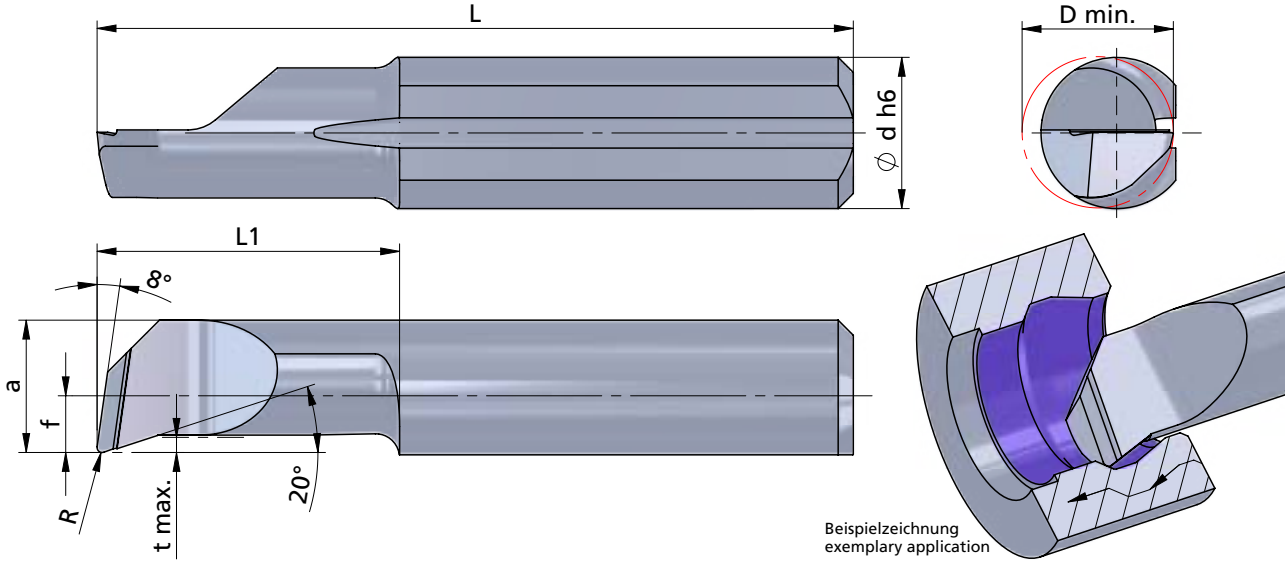
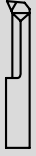

Rechts (R): wie gezeichnet
Links (L): spiegelbildlich

righthand (R): as shown
lefthand version (L): mirror image

Abmessungen in mm

dimensions in mm

Bestellnummer part number	R	f	a	L	L1	t max.	D min.	Ø d h6	K10F CN45F AL41F PD2F	Klemmhalter Typ toolholder type
R/L 050.6-15C	0.15	2.3	5.3	30	15	0.5	6.0	6.0	●	676... 660... ...6
R/L 050.6-22C	0.15	2.3	5.3	37	22	0.5	6.0	6.0	●	
R/L 050.6-25C	0.15	2.3	5.3	40	25	0.5	6.0	6.0	●	
R/L 050.6-30C	0.15	2.3	5.3	45	30	0.5	6.0	6.0	●	
R/L 050.6-35C	0.15	2.3	5.3	50	35	0.5	6.0	6.0	●	
R/L 050.6-42C	0.15	2.3	5.3	57	42	0.5	6.0	6.0	●	
R/L 050.7-20C	0.15	2.8	6.3	35	20	0.6	6.8	7.0	●	676... 670... 687... ...7
R/L 050.7-25C	0.15	2.8	6.3	40	25	0.6	6.8	7.0	●	
R/L 050.7-30C	0.15	2.8	6.3	45	30	0.6	6.8	7.0	●	
R/L 050.7-35C	0.15	2.8	6.3	50	35	0.6	6.8	7.0	●	
R/L 050.7-40C	0.15	2.8	6.3	55	40	0.6	6.8	7.0	●	
R/L 050.7-45C	0.15	2.8	6.3	60	45	0.6	6.8	7.0	●	
R/L 050.7-50C	0.15	2.8	6.3	65	50	0.6	6.8	7.0	●	

Weitere HM Sorten können Sie in der Sortenübersicht im Kapitel "Technische Hinweise" und der Preisliste finden.

More carbide grades you can find in the grades summary in the chapter "technical instructions" and in the price list.

ULTRAMINI

Bohrungsbearbeitung
ab \varnothing 0.2 mm

grooving, boring and profiling
starting at \varnothing 0.2 mm

Typ P50...C

Ausdrehen und Kopieren
mit Spantreppe
für bessere Spankontrolle
und innerer Kühlmittelzufuhr

boring and profiling
with chipbreaker
for better chipcontrol
and through coolant

Performanceline

D min. 2.0 - 6.8 mm
Auskrägung (L1) bis 7x D

D min. 2.0 - 6.8 mm
overhang length (L1) up to 7x D

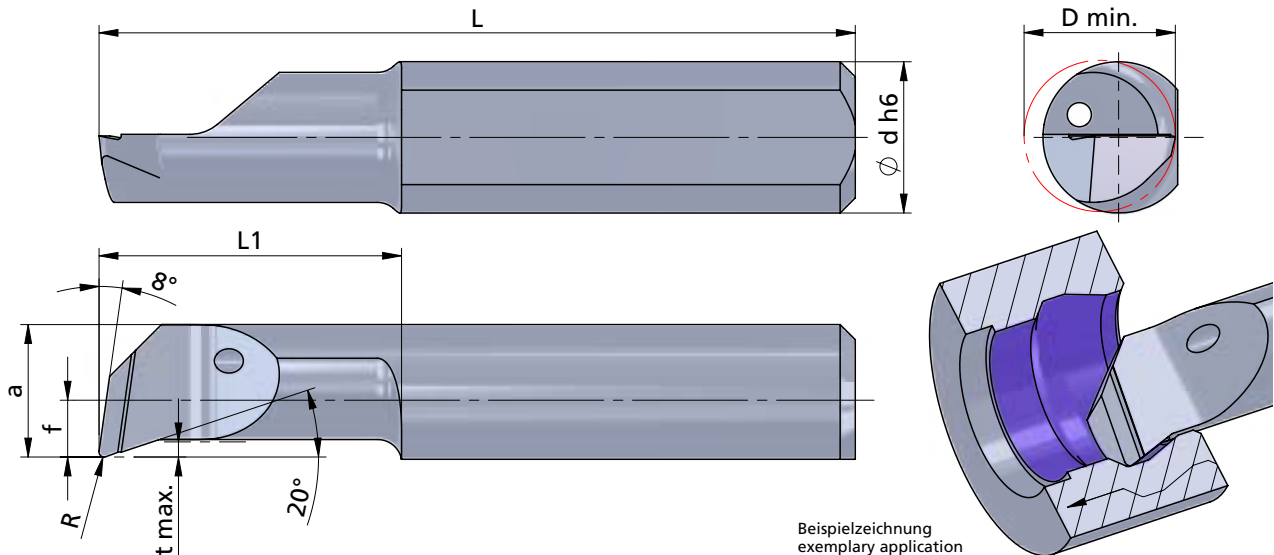

Beispielzeichnung
exemplary application

Rechts (R): wie gezeichnet
Links (L): spiegelbildlich

righthand (R): as shown
lefthand version (L): mirror image



Abmessungen in mm

dimensions in mm

Bestellnummer part number	R	f	a	L	L1	t max.	D min.	\varnothing d h6	K10F P04C AL41F PD2F	Klemmhalter Typ toolholder type	
										645...	640... ...4
R/L P50.2-10C	0.05	-0.3	1.7	24	10	0.1	2.0	4.0	●	645...	640... ...4
R/L P50.3-10C	0.1	0.6	2.6	24	10	0.2	2.8	4.0	●		
R/L P50.3-16C	0.1	0.6	2.6	30	16	0.2	2.8	4.0	●		
R/L P50.4-10C	0.1	1.5	3.5	24	10	0.3	4.0	4.0	●		
R/L P50.4-16C	0.1	1.5	3.5	30	16	0.3	4.0	4.0	●		
R/L P50.4-20C	0.1	1.5	3.5	34	20	0.3	4.0	4.0	●		
R/L P50.4-24C	0.1	1.5	3.5	38	24	0.3	4.0	4.0	●		
R/L P50.4-28C	0.1	1.5	3.5	42	28	0.3	4.0	4.0	●	650... ...5	
R/L P50.5-10C	0.15	1.9	4.4	25	10	0.5	5.0	5.0	●		
R/L P50.5-15C	0.15	1.9	4.4	30	15	0.5	5.0	5.0	●		
R/L P50.5-20C	0.15	1.9	4.4	35	20	0.5	5.0	5.0	●		
R/L P50.5-25C	0.15	1.9	4.4	40	25	0.5	5.0	5.0	●		
R/L P50.5-30C	0.15	1.9	4.4	45	30	0.5	5.0	5.0	●		
R/L P50.5-35C	0.15	1.9	4.4	50	35	0.5	5.0	5.0	●		

Weitere HM Sorten können Sie in der Sortenübersicht im Kapitel "Technische Hinweise" und der Preisliste finden.

Bestellbeispiel:
für rechte Ausführung und Sorte
RP50.2-10C/P04C

More carbide grades you can find in the grades summary in the chapter "technical instructions" and in the price list.

order-example:
righthand version and grade
RP50.2-10C/P04C

ULTRAMINI

Bohrungsbearbeitung
ab Ø 0.2 mm

grooving, boring and profiling
starting at Ø 0.2 mm

Typ P50...C

Ausdrehen und Kopieren
mit Spantreppe
für bessere Spankontrolle
und innerer Kühlmittelzufuhr

boring and profiling
with chipbreaker
for better chipcontrol
and through coolant

Performanceline

D min. 2.0 - 6.8 mm
Auskrägung (L1) bis 7x D

D min. 2.0 - 6.8 mm
overhang length (L1) up to 7x D

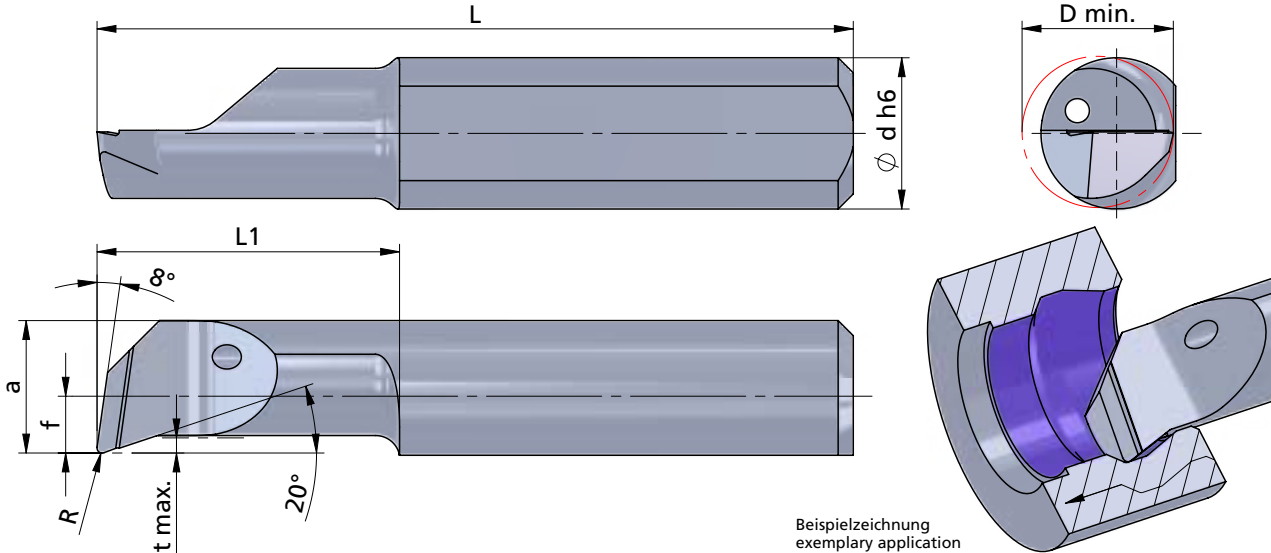

Beispielzeichnung
exemplary application

Rechts (R): wie gezeichnet
Links (L): spiegelbildlich

righthand (R): as shown
lefthand version (L): mirror image

Abmessungen in mm

dimensions in mm



Bestellnummer part number	R	f	a	L	L1	t max.	D min.	Ø d h6	K10F P04C AL41F PD2F	Klemmhalter Typ toolholder type
⋮ ↴										
R/L P50.6-15C	0.15	2.3	5.3	30	15	0.5	6.0	6.0	●	676... 660... ...6
R/L P50.6-22C	0.15	2.3	5.3	37	22	0.5	6.0	6.0	●	
R/L P50.6-25C	0.15	2.3	5.3	40	25	0.5	6.0	6.0	●	
R/L P50.6-30C	0.15	2.3	5.3	45	30	0.5	6.0	6.0	●	
R/L P50.6-35C	0.15	2.3	5.3	50	35	0.5	6.0	6.0	●	
R/L P50.6-42C	0.15	2.3	5.3	57	42	0.5	6.0	6.0	●	
R/L P50.7-20C	0.15	2.8	6.3	35	20	0.6	6.8	7.0	●	670... 687... ...7
R/L P50.7-25C	0.15	2.8	6.3	40	25	0.6	6.8	7.0	●	
R/L P50.7-30C	0.15	2.8	6.3	45	30	0.6	6.8	7.0	●	
R/L P50.7-35C	0.15	2.8	6.3	50	35	0.6	6.8	7.0	●	
R/L P50.7-40C	0.15	2.8	6.3	55	40	0.6	6.8	7.0	●	
R/L P50.7-45C	0.15	2.8	6.3	60	45	0.6	6.8	7.0	●	
R/L P50.7-50C	0.15	2.8	6.3	65	50	0.6	6.8	7.0	●	

Weitere HM Sorten können Sie in der Sortenübersicht im Kapitel "Technische Hinweise" und der Preisliste finden.

More carbide grades you can find in the grades summary in the chapter "technical instructions" and in the price list.

Bestellbeispiel:
für rechte Ausführung und Sorte
RP50.6-15C/P04C

order-example:
righthand version and grade
RP50.6-15C/P04C

ULTRAMINI

Bohrungsbearbeitung
ab \varnothing 0.2 mm

grooving, boring and profiling
starting at \varnothing 0.2 mm

Typ M050

Ausdrehen und Kopieren
mit innerer Kühlmittelzufuhr
und modifizierter Geometrie

boring and profiling
with through coolant
and modified profile

Mediline

D min. 0.5 - 4.0 mm

D min. 0.5 - 4.0 mm

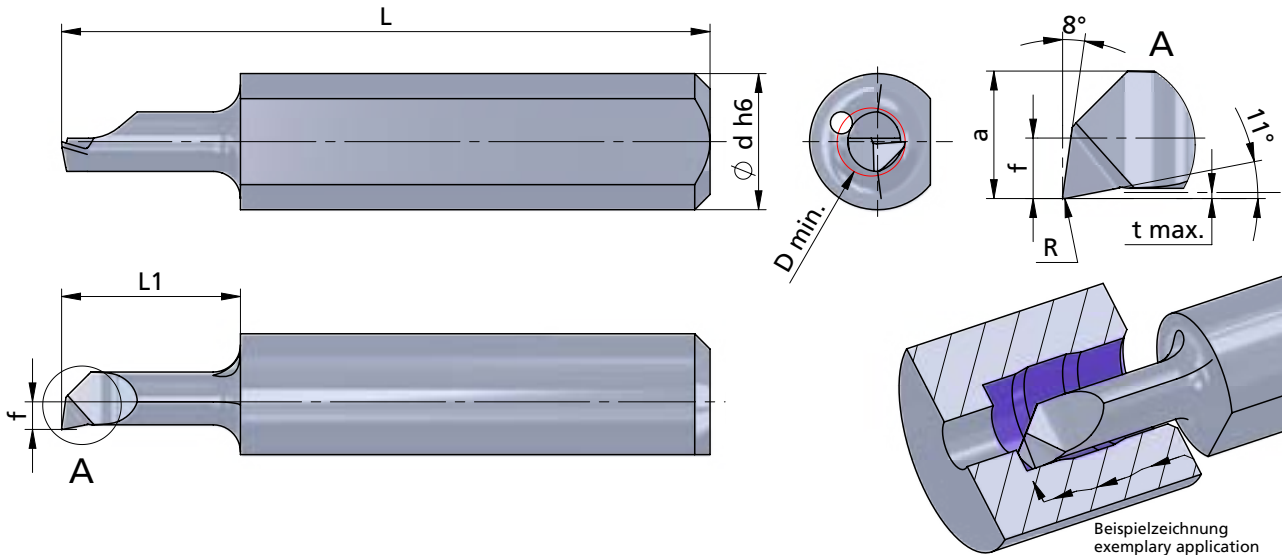

Rechts (R): wie gezeichnet
Links (L): spiegelbildlich

righthand (R): as shown
lefthand version (L): mirror image



Abmessungen in mm

dimensions in mm

Bestellnummer part number	R	f	a	L	L1	t max.	D min.	Ø d h6	K10F	CN45F	AL41F	P07C	Klemmhalter Typ	toolholder type
													640... 645... ...4	
R/L M050.05-2	0.02	0.2	0.4	20	2	0.02	0.5	4.0	●			●		
R/L M050.08-4	0.02	0.35	0.7	20	4	0.03	0.8	4.0	●			●		
R/L M050.1-5	0.02	0.4	0.9	20	5	0.05	1	4.0	●			●		
R/L M050.1-7	0.02	0.4	0.9	22	7	0.05	1	4.0	●			●		
R/L M050.15-5	0.02	0.6	1.35	19	5	0.08	1.5	4.0	●			●		
R/L M050.15-10	0.02	0.6	1.35	24	10	0.08	1.5	4.0	●			●		
R/L M050.2-5	0.02	0.8	1.7	19	5	0.08	2	4.0	●			●		
R/L M050.2-10	0.02	0.8	1.7	24	10	0.08	2	4.0	●			●		
↳ ...														

Weitere HM Sorten können Sie in der Sortenübersicht im Kapitel "Technische Hinweise" und der Preisliste finden.

Bestellbeispiel:
für rechte Ausführung und Sorte
RM050.05-2/P07C

weitere Informationen:

- siehe Allgemeine Beschreibung

more informations:

- look at the general instructions

More carbide grades you can find in the grades summary in the chapter "technical instructions" and in the price list.

order-example:
righthand version and grade
RM050.05-2/P07C

ULTRAMINI

Bohrungsbearbeitung
ab $\varnothing 0.2$ mm

grooving, boring and profiling
starting at $\varnothing 0.2$ mm

Typ M050

Ausdrehen und Kopieren
mit innerer Kühlmittelzufuhr
und modifizierter Geometrie

boring and profiling
with through coolant
and modified profile

Mediline

D min. 0.5 - 4.0 mm

D min. 0.5 - 4.0 mm

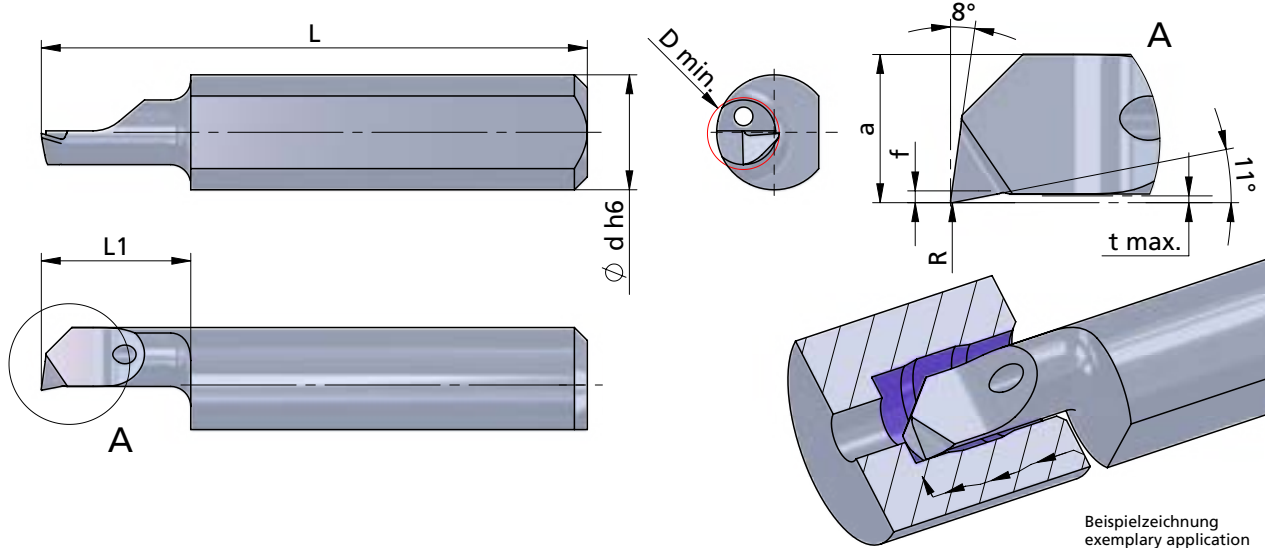

Beispielzeichnung
exemplary application

Rechts (R): wie gezeichnet
Links (L): spiegelbildlich

righthand (R): as shown
lefthand version (L): mirror image

Abmessungen in mm

dimensions in mm



Bestellnummer part number	R	f	a	L	L1	t max.	D min.	Ø d h6					Klemmhalter Typ toolholder type	
									K10F	CN45F	AL41F	P07C		
...														
R/L M050.25-5	0.02	0.2	2.2	19	5	0.1	2.5	4.0	●			●	640... 645... ...4	
R/L M050.25-10	0.02	0.2	2.2	24	10	0.1	2.5	4.0	●			●		
R/L M050.3-10	0.02	0.6	2.6	24	10	0.15	3	4.0	●			●		
R/L M050.3-16	0.02	0.6	2.6	30	16	0.15	3	4.0	●			●		
R/L M050.35-10	0.02	1.1	3.1	24	10	0.17	3.5	4.0	●			●		
R/L M050.35-16	0.02	1.1	3.1	30	16	0.17	3.5	4.0	●			●		
R/L M050.35-20	0.02	1.1	3.1	34	20	0.17	3.5	4.0	●			●		
R/L M050.4-10	0.02	1.5	3.5	24	10	0.2	4	4.0	●			●		
R/L M050.4-16	0.02	1.5	3.5	30	16	0.2	4	4.0	●			●		
R/L M050.4-20	0.02	1.5	3.5	34	20	0.2	4	4.0	●			●		
R/L M050.4-24	0.02	1.5	3.5	38	24	0.2	4	4.0	●			●		

Weitere HM Sorten können Sie in der Sortenübersicht im Kapitel "Technische Hinweise" und der Preisliste finden.

weitere Informationen:
• siehe Allgemeine Beschreibung

More carbide grades you can find in the grades summary in the chapter "technical instructions" and in the price list.

Bestellbeispiel:
für rechte Ausführung und Sorte
RM050.25-5/P07C

more informations:
• look at the general instructions

order-example:
righthand version and grade
RM050.25-5/P07C

ULTRAMINI

Bohrungsbearbeitung
ab Ø 0.2 mm

grooving, boring and profiling
starting at Ø 0.2 mm

Typ X050

Ausdrehen und Kopieren
mit innerer Kühlmittelzufuhr,
Spanteppe, extra stabile Ausführung

boring and profiling
with through coolant, chipbreaker
and extra solid construction

Xtraline

D min. 1.0 - 7.0 mm

D min. 1.0 - 7.0 mm

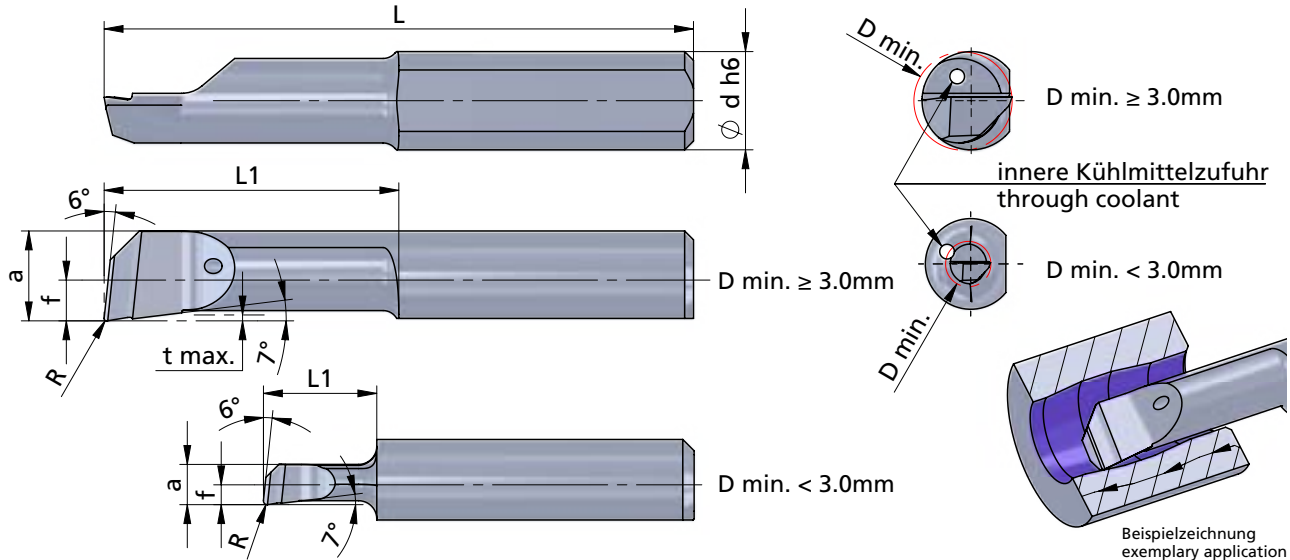

Beispielzeichnung
exemplary application

Rechts (R): wie gezeichnet
Links (L): spiegelbildlich

righthand (R): as shown
lefthand version (L): mirror image

Abmessungen in mm

dimensions in mm



Bestellnummer part number	R	f	a	L	L1	t max.	D min.	Ø d h6	K10F CN45F AL41F P18C	Klemmhalter Typ	toolholder type
R/L X050.1-5R05	0.05	0.45	0.9	20	5	0.03	1.0	4.0	●		
R/L X050.15-7R10	0.1	0.65	1.35	21	7	0.05	1.5	4.0	●		
R/L X050.2-5R15	0.15	0.9	1.8	19	5	0.1	2.0	4.0	●		
R/L X050.2-10R05	0.05	0.9	1.8	24	10	0.1	2.0	4.0	●		
R/L X050.2-10R15	0.15	0.9	1.8	24	10	0.1	2.0	4.0	●		
R/L X050.2-15R15	0.15	0.9	1.8	29	15	0.1	2.0	4.0	●		
R/L X050.3-10R05	0.05	0.7	2.7	24	10	0.15	3.0	4.0	●		
R/L X050.3-10R20	0.2	0.7	2.7	24	10	0.15	3.0	4.0	●		
R/L X050.3-16R05	0.05	0.7	2.7	30	16	0.15	3.0	4.0	●		
R/L X050.3-16R10	0.1	0.7	2.7	30	16	0.15	3.0	4.0	●		
R/L X050.3-16R20	0.2	0.7	2.7	30	16	0.15	3.0	4.0	●		
↳ ...											

Weitere HM Sorten können Sie in der Sortenübersicht im Kapitel "Technische Hinweise" und der Preisliste finden.

Bestellbeispiel:
für rechte Ausführung und Sorte
RX050.1-5R05/P18C

weitere Informationen:

- siehe Allgemeine Beschreibung

more informations:

- look at the general instructions

More carbide grades you can find in the grades summary in the chapter "technical instructions" and in the price list.

order-example:
righthand version and grade
RX050.1-5R05/P18C

ULTRAMINI

Bohrungsbearbeitung
ab \varnothing 0.2 mm

grooving, boring and profiling
starting at \varnothing 0.2 mm

Typ X050

Ausdrehen und Kopieren
mit innerer Kühlmittelzufuhr,
Spanteppe, extra stabile Ausführung

boring and profiling
with through coolant, chipbreaker
and extra solid construction

Xtraline

D min. 1.0 - 7.0 mm

D min. 1.0 - 7.0 mm

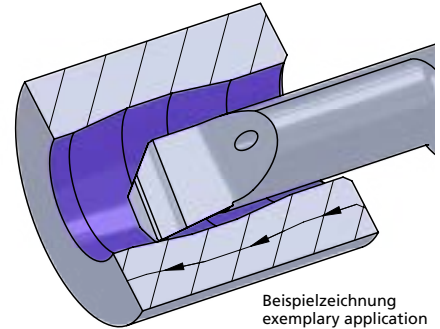
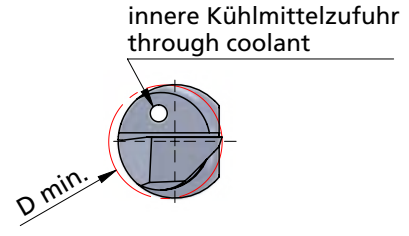
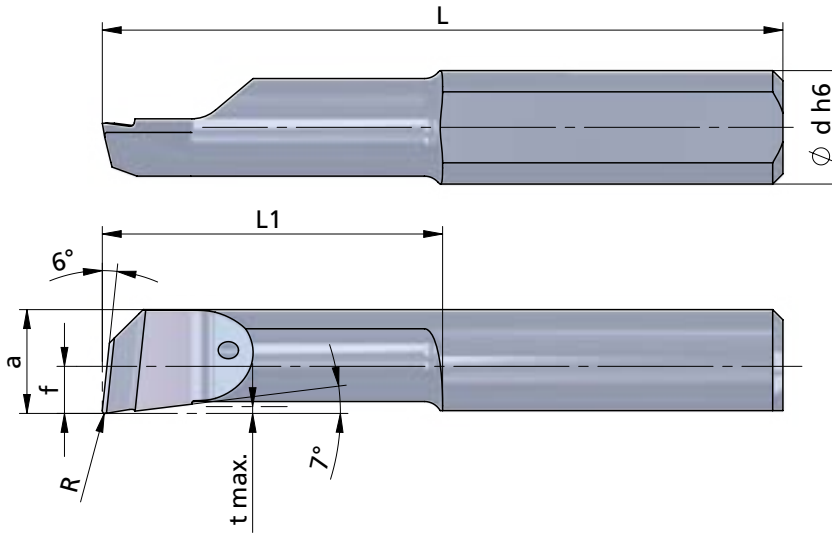
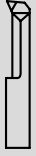

Rechts (R): wie gezeichnet
Links (L): spiegelbildlich

righthand (R): as shown
lefthand version (L): mirror image

Abmessungen in mm

dimensions in mm



Bestellnummer
part number

	R	f	a	L	L1	t max.	D min.	\varnothing d h6	K10F	CN45F	AL41F	P18C	Klemmhalter Typ	toolholder type
...														
R/L X050.4-10R10	0.1	1.6	3.6	24	10	0.2	4.0	4.0	●			●	640... 645... ...4	
R/L X050.4-10R20	0.2	1.6	3.6	24	10	0.2	4.0	4.0	●			●		
R/L X050.4-16R05	0.05	1.6	3.6	30	16	0.2	4.0	4.0	●			●		
R/L X050.4-16R10	0.1	1.6	3.6	30	16	0.2	4.0	4.0	●			●		
R/L X050.4-16R20	0.2	1.6	3.6	30	16	0.2	4.0	4.0	●			●		
R/L X050.4-16R40	0.4	1.6	3.6	30	16	0.2	4.0	4.0				●		
R/L X050.4-24R10	0.1	1.6	3.6	38	24	0.2	4.0	4.0	●			●		
R/L X050.4-24R20	0.2	1.6	3.6	38	24	0.2	4.0	4.0	●			●		
R/L X050.4-24R40	0.4	1.6	3.6	38	24	0.2	4.0	4.0				●		
...														

Weitere HM Sorten können Sie in der Sortenübersicht im Kapitel "Technische Hinweise" und der Preisliste finden.

weitere Informationen:
• siehe Allgemeine Beschreibung

More carbide grades you can find in the grades summary in the chapter "technical instructions" and in the price list.

Bestellbeispiel:
für rechte Ausführung und Sorte
RX050.4-10R10/P18C

more informations:
• look at the general instructions

order-example:
righthand version and grade
RX050.4-10R10/P18C

ULTRAMINI

Bohrungsbearbeitung
ab \varnothing 0.2 mm

grooving, boring and profiling
starting at \varnothing 0.2 mm

Typ X050

Ausdrehen und Kopieren
mit innerer Kühlmittelzufuhr,
Spanteppe, extra stabile Ausführung

boring and profiling
with through coolant, chipbreaker
and extra solid construction

Xtraline

D min. 1.0 - 7.0 mm

D min. 1.0 - 7.0 mm

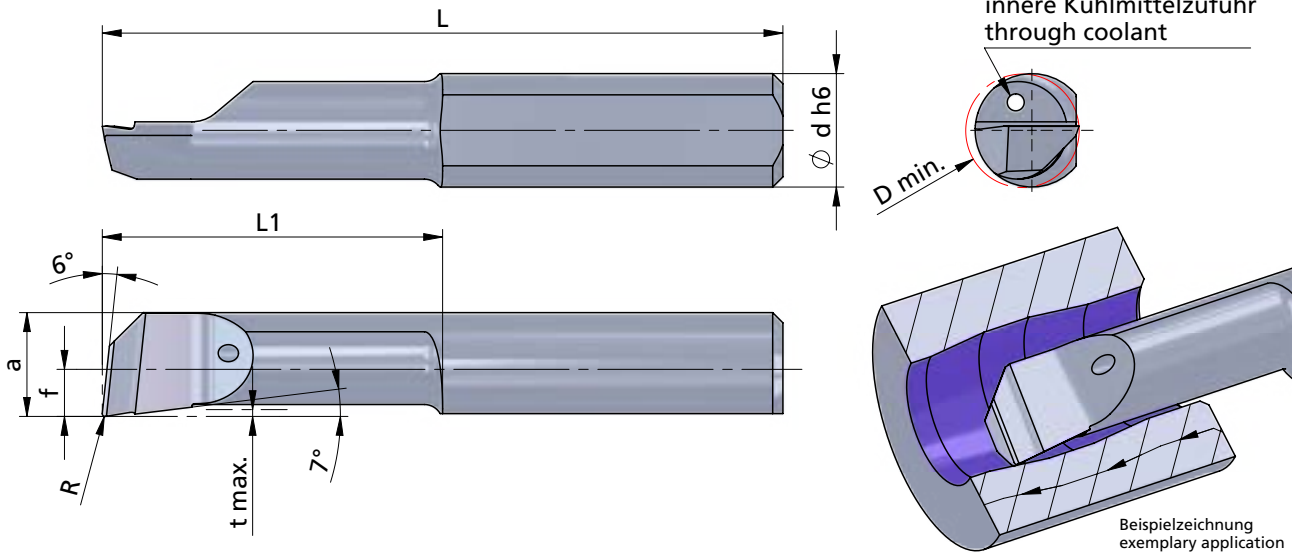

Rechts (R): wie gezeichnet
Links (L): spiegelbildlich

righthand (R): as shown
lefthand version (L): mirror image



Abmessungen in mm

dimensions in mm

Bestellnummer part number	R	f	a	L	L1	t max.	D min.	Ø d h6	Klemmhalter Typ toolholder type				
									K10F	CN45F	AL41F	P18C	
R/L X050.5-15R05	0.05	2.1	4.6	30	15	0.3	5.0	5.0	●		●		
R/L X050.5-15R10	0.1	2.1	4.6	30	15	0.3	5.0	5.0	●		●		
R/L X050.5-15R20	0.2	2.1	4.6	30	15	0.3	5.0	5.0	●		●		
R/L X050.5-15R40	0.4	2.1	4.6	30	15	0.3	5.0	5.0	●		●		
R/L X050.5-25R10	0.1	2.1	4.6	40	25	0.3	5.0	5.0	●		●		645... 650... ...5
R/L X050.5-25R20	0.2	2.1	4.6	40	25	0.3	5.0	5.0	●		●		
R/L X050.5-30R10	0.1	2.1	4.6	45	30	0.3	5.0	5.0	●		●		
R/L X050.5-30R20	0.2	2.1	4.6	45	30	0.3	5.0	5.0	●		●		
R/L X050.5-30R40	0.4	2.1	4.6	45	30	0.3	5.0	5.0	●		●		

Weitere HM Sorten können Sie in der Sortenübersicht im Kapitel "Technische Hinweise" und der Preisliste finden.

Bestellbeispiel:
für rechte Ausführung und Sorte
RX050.5-15R05/P18C

weitere Informationen:

- siehe Allgemeine Beschreibung

more informations:

- look at the general instructions

More carbide grades you can find in the grades summary in the chapter "technical instructions" and in the price list.

order-example:
righthand version and grade
RX050.5-15R05/P18C

ULTRAMINI

Bohrungsbearbeitung
ab \varnothing 0.2 mm

grooving, boring and profiling
starting at \varnothing 0.2 mm

Typ X050

Ausdrehen und Kopieren
mit innerer Kühlmittelzufuhr,
Spanteppe, extra stabile Ausführung

boring and profiling
with through coolant, chipbreaker
and extra solid construction

Xtraline

D min. 1.0 - 7.0 mm

D min. 1.0 - 7.0 mm

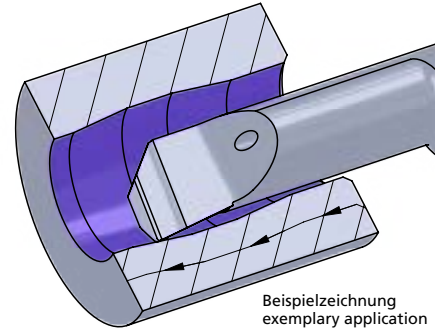
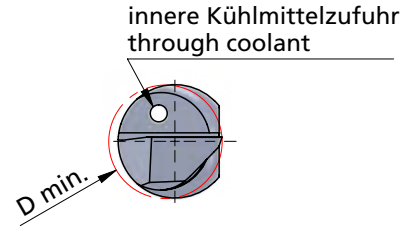
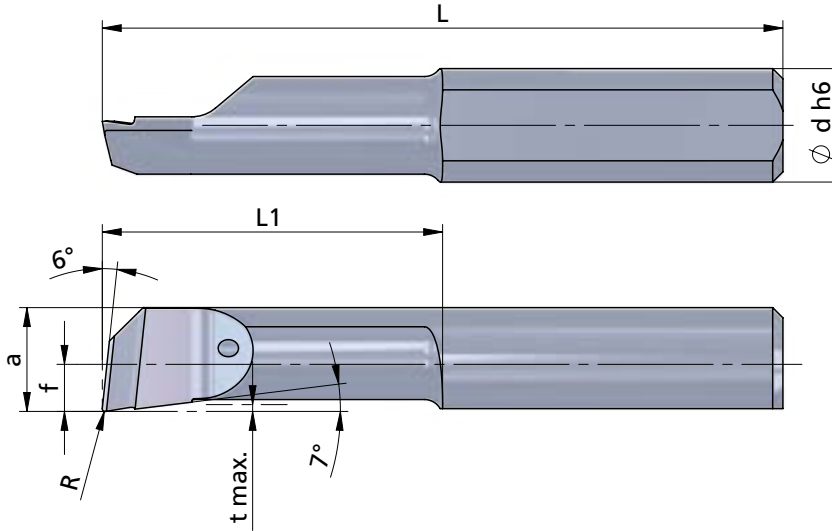
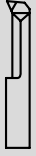

Rechts (R): wie gezeichnet
Links (L): spiegelbildlich

righthand (R): as shown
lefthand version (L): mirror image

Abmessungen in mm

dimensions in mm



Bestellnummer part number	R	f	a	L	L1	t max.	D min.	\varnothing d h6	K10F CN45F AL41F P18C	Klemmhalter Typ	toolholder type
⋮ ↘											
R/L X050.6-15R05	0.05	2.5	5.5	30	15	0.4	6.0	6.0	●	●	
R/L X050.6-15R10	0.1	2.5	5.5	30	15	0.4	6.0	6.0	●	●	
R/L X050.6-15R20	0.2	2.5	5.5	30	15	0.4	6.0	6.0	●	●	
R/L X050.6-15R40	0.4	2.5	5.5	30	15	0.4	6.0	6.0	●	●	
R/L X050.6-22R20	0.2	2.5	5.5	37	22	0.4	6.0	6.0	●	●	
R/L X050.6-30R20	0.2	2.5	5.5	45	30	0.4	6.0	6.0	●	●	676... 660... ...6
R/L X050.6-30R40	0.4	2.5	5.5	45	30	0.4	6.0	6.0	●	●	
R/L X050.6-35R20	0.2	2.5	5.5	50	35	0.4	6.0	6.0	●	●	
R/L X050.6-42R20	0.2	2.5	5.5	57	42	0.4	6.0	6.0	●	●	
R/L X050.6-50R20	0.2	2.5	5.5	65	50	0.4	6.0	6.0	●	●	
↙ ...											

Weitere HM Sorten können Sie in der Sortenübersicht im Kapitel "Technische Hinweise" und der Preisliste finden.

weitere Informationen:
• siehe Allgemeine Beschreibung

More carbide grades you can find in the grades summary in the chapter "technical instructions" and in the price list.

Bestellbeispiel:
für rechte Ausführung und Sorte
RX050.6-15R05/P18C

more informations:
• look at the general instructions

order-example:
righthand version and grade
RX050.6-15R05/P18C

ULTRAMINI

Bohrungsbearbeitung
ab \varnothing 0.2 mm

grooving, boring and profiling
starting at \varnothing 0.2 mm

Typ X050

Ausdrehen und Kopieren
mit innerer Kühlmittelzufuhr,
Spanteppe, extra stabile Ausführung

boring and profiling
with through coolant, chipbreaker
and extra solid construction

Xtraline

D min. 1.0 - 7.0 mm

D min. 1.0 - 7.0 mm

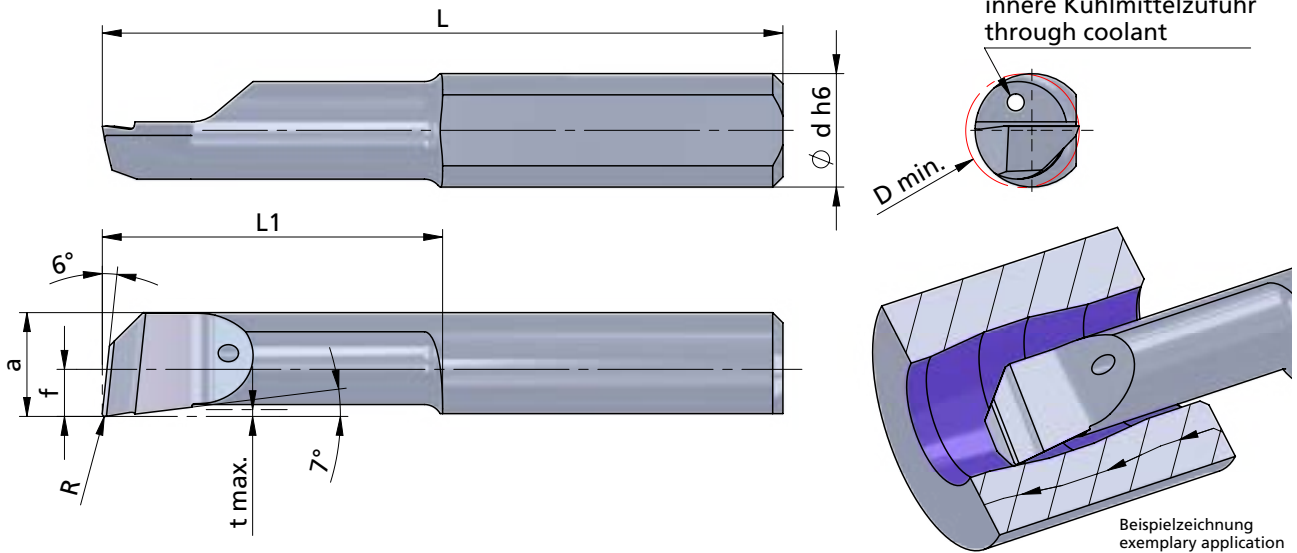

Rechts (R): wie gezeichnet
Links (L): spiegelbildlich

righthand (R): as shown
lefthand version (L): mirror image

Abmessungen in mm

dimensions in mm



Bestellnummer part number	R	f	a	L	L1	t max.	D min.	Ø d h6	K10F CN45F AL41F P18C	Klemmhalter Typ	toolholder type
										676... 670... 687... ...7	
R/L X050.7-25R20	0.2	3	6.5	40	25	0.5	7.0	7.0	●	●	
R/L X050.7-30R20	0.2	3	6.5	45	30	0.5	7.0	7.0	●	●	
R/L X050.7-30R40	0.4	3	6.5	45	30	0.5	7.0	7.0	●	●	
R/L X050.7-35R20	0.2	3	6.5	50	35	0.5	7.0	7.0	●	●	
R/L X050.7-40R20	0.2	3	6.5	55	40	0.5	7.0	7.0	●	●	
R/L X050.7-45R20	0.2	3	6.5	60	45	0.5	7.0	7.0	●	●	
R/L X050.7-50R20	0.2	3	6.5	65	50	0.5	7.0	7.0	●	●	

Weitere HM Sorten können Sie in der Sortenübersicht im Kapitel "Technische Hinweise" und der Preisliste finden.

Bestellbeispiel:
für rechte Ausführung und Sorte
RX050.7-25R20/P18C

weitere Informationen:

- siehe Allgemeine Beschreibung

more informations:

- look at the general instructions

More carbide grades you can find in the grades summary in the chapter "technical instructions" and in the price list.

order-example:
righthand version and grade
RX050.7-25R20/P18C

ULTRAMINI

Bohrungsbearbeitung
ab Ø 0.2 mm

grooving, boring and profiling
starting at Ø 0.2 mm

Typ 050

Ausdrehen und Kopieren,
für Hartbearbeitung bis 66 HRC

boring and profiling,
for hard machining up to 66 HRC

Hardline

D min. 2.0 - 6.8 mm
Auskrägung (L1) bis 7x D

D min. 2.0 - 6.8 mm
overhang length (L1) up to 7x D

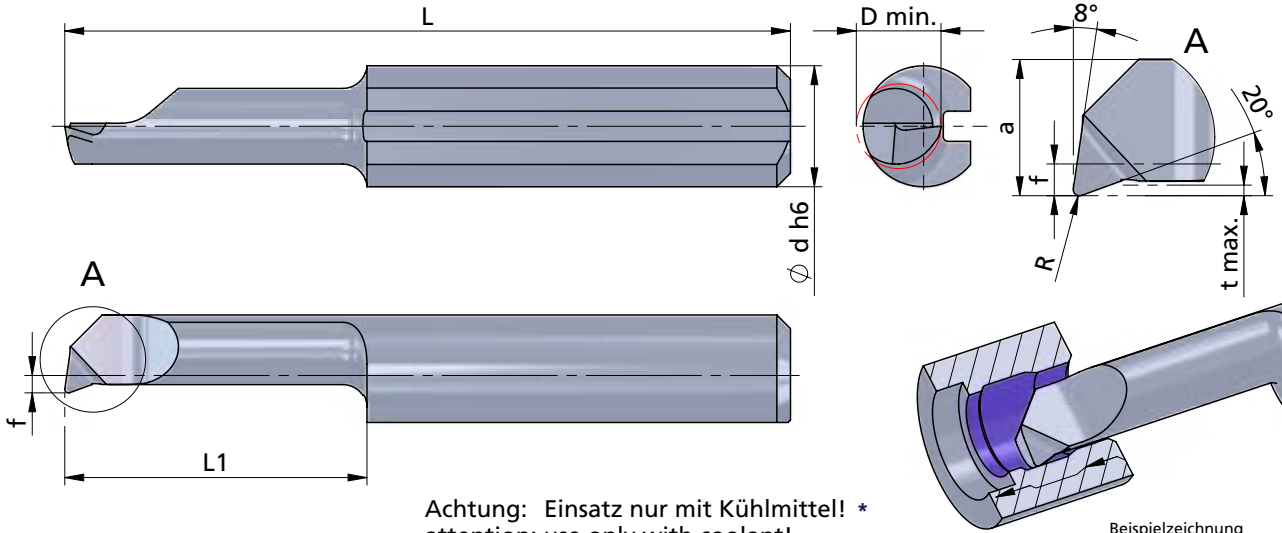

Rechts (R): wie gezeichnet
Links (L): spiegelbildlich

righthand (R): as shown
lefthand version (L): mirror image



Abmessungen in mm

dimensions in mm

Bestellnummer part number	R	f	a	L	L1	t max.	D min.	Ø d h6	K10F	CN45F	AL41F	XC2A-NH	Klemmhalter Typ	toolholder type
													645...	640... ...4
R/L 050.2-5/XC2A-NH	0.05	-0.3	1.7	19	5	0.1	2.0	4.0					645...	640... ...4
R/L 050.2-10/XC2A-NH	0.05	-0.3	1.7	24	10	0.1	2.0	4.0						
R/L 050.2-15/XC2A-NH	0.05	-0.3	1.7	29	15	0.1	2.0	4.0						
R/L 050.3-10/XC2A-NH	0.1	0.6	2.6	24	10	0.2	2.8	4.0						
R/L 050.3-16/XC2A-NH	0.1	0.6	2.6	30	16	0.2	2.8	4.0						
R/L 050.3-20/XC2A-NH	0.1	0.6	2.6	34	20	0.2	2.8	4.0						
R/L 050.4-10/XC2A-NH	0.1	1.5	3.5	24	10	0.3	4.0	4.0						
R/L 050.4-16/XC2A-NH	0.1	1.5	3.5	30	16	0.3	4.0	4.0						
R/L 050.4-20/XC2A-NH	0.1	1.5	3.5	34	20	0.3	4.0	4.0						
R/L 050.4-24/XC2A-NH	0.1	1.5	3.5	38	24	0.3	4.0	4.0						
R/L 050.4-28/XC2A-NH	0.1	1.5	3.5	42	28	0.3	4.0	4.0						
R/L 050.5-10/XC2A-NH	0.15	1.9	4.4	25	10	0.5	5.0	5.0					650... ...5	
R/L 050.5-15/XC2A-NH	0.15	1.9	4.4	30	15	0.5	5.0	5.0						
R/L 050.5-20/XC2A-NH	0.15	1.9	4.4	35	20	0.5	5.0	5.0						
R/L 050.5-25/XC2A-NH	0.15	1.9	4.4	40	25	0.5	5.0	5.0						
↳ ...														

weitere Informationen:
• siehe Allgemeine Beschreibung
* siehe Technische Hinweise

more informations:
• look at the general instructions
* look at the technical instructions

order-example:
righthand version and grade
R050.2-5/XC2A-NH

ULTRAMINI

Bohrungsbearbeitung
ab Ø 0.2 mm

grooving, boring and profiling
starting at Ø 0.2 mm

Typ 050

Ausdrehen und Kopieren,
für Hartbearbeitung bis 66 HRC

boring and profiling,
for hard machining up to 66 HRC

Hardline

D min. 2.0 - 6.8 mm
Auskrägung (L1) bis 7x D

D min. 2.0 - 6.8 mm
overhang length (L1) up to 7x D

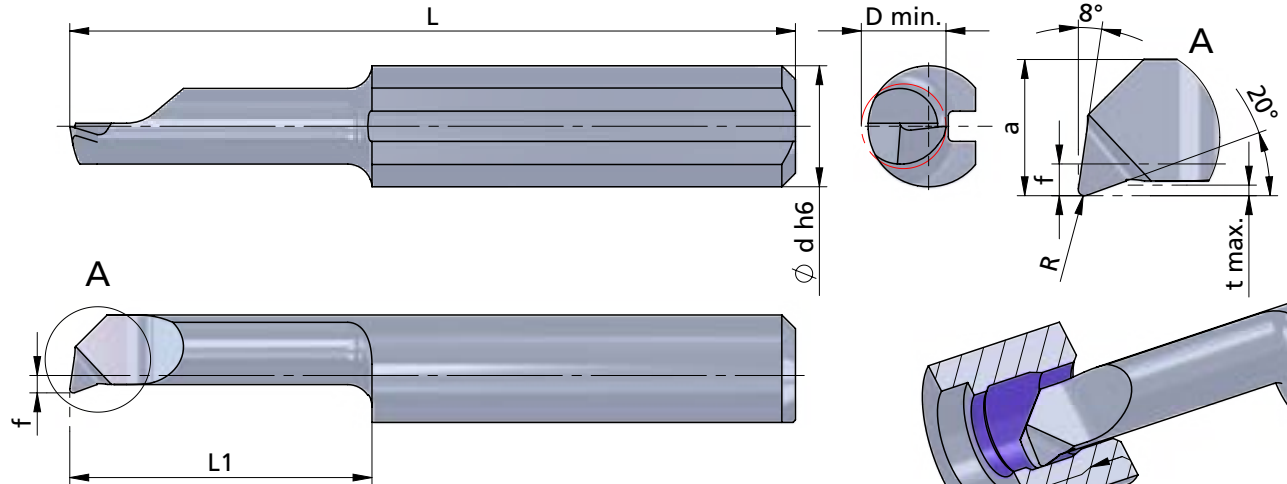

Achtung: Einsatz nur mit Kühlmittel! *
attention: use only with coolant! *

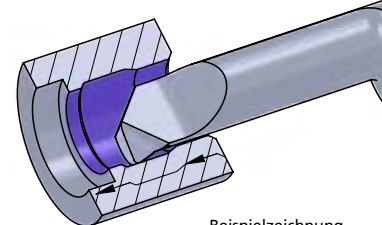

Beispielzeichnung
exemplary application

Rechts (R): wie gezeichnet
Links (L): spiegelbildlich

righthand (R): as shown
lefthand version (L): mirror image



Abmessungen in mm

dimensions in mm

Bestellnummer part number														Klemhalter Typ toolholder type
	R	f	a	L	L1	t max.	D min.	Ø d h6	K10F	CN45F	AL41F	XC2A-NH		
R/L 050.5-30/XC2A-NH	0.15	1.9	4.4	45	30	0.5	5.0	5.0				●	645... 650... ...5	
R/L 050.5-35/XC2A-NH	0.15	1.9	4.4	50	35	0.5	5.0	5.0				●		
R/L 050.6-15/XC2A-NH	0.15	2.3	5.3	30	15	0.5	6.0	6.0				●	676... 660... ...6	
R/L 050.6-22/XC2A-NH	0.15	2.3	5.3	37	22	0.5	6.0	6.0				●		
R/L 050.6-25/XC2A-NH	0.15	2.3	5.3	40	25	0.5	6.0	6.0				●		
R/L 050.6-30/XC2A-NH	0.15	2.3	5.3	45	30	0.5	6.0	6.0				●		
R/L 050.6-35/XC2A-NH	0.15	2.3	5.3	50	35	0.5	6.0	6.0				●		
R/L 050.6-42/XC2A-NH	0.15	2.3	5.3	57	42	0.5	6.0	6.0				●		
R/L 050.7-20/XC2A-NH	0.15	2.8	6.3	35	20	0.6	6.8	7.0				●	670... 687... ...7	
R/L 050.7-25/XC2A-NH	0.15	2.8	6.3	40	25	0.6	6.8	7.0				●		
R/L 050.7-30/XC2A-NH	0.15	2.8	6.3	45	30	0.6	6.8	7.0				●		
R/L 050.7-35/XC2A-NH	0.15	2.8	6.3	50	35	0.6	6.8	7.0				●		
R/L 050.7-40/XC2A-NH	0.15	2.8	6.3	55	40	0.6	6.8	7.0				●		
R/L 050.7-45/XC2A-NH	0.15	2.8	6.3	60	45	0.6	6.8	7.0				●		
R/L 050.7-50/XC2A-NH	0.15	2.8	6.3	65	50	0.6	6.8	7.0				●		

Bestellbeispiel:
für rechte Ausführung und Sorte
R050.5-30/XC2A-NH

weitere Informationen:
• siehe Allgemeine Beschreibung
* siehe Technische Hinweise

more informations:
• look at the general instructions
* look at the technical instructions

order-example:
righthand version and grade
R050.5-30/XC2A-NH

ULTRAMINI

Bohrungsbearbeitung
ab \varnothing 0.2 mm

grooving, boring and profiling
starting at \varnothing 0.2 mm

Typ 050.../CBN

Ausdrehen und Kopieren,
für Hartbearbeitung

boring and profiling,
for hard machining

D min. 1.0 - 6.8 mm

D min. 1.0 - 6.8 mm

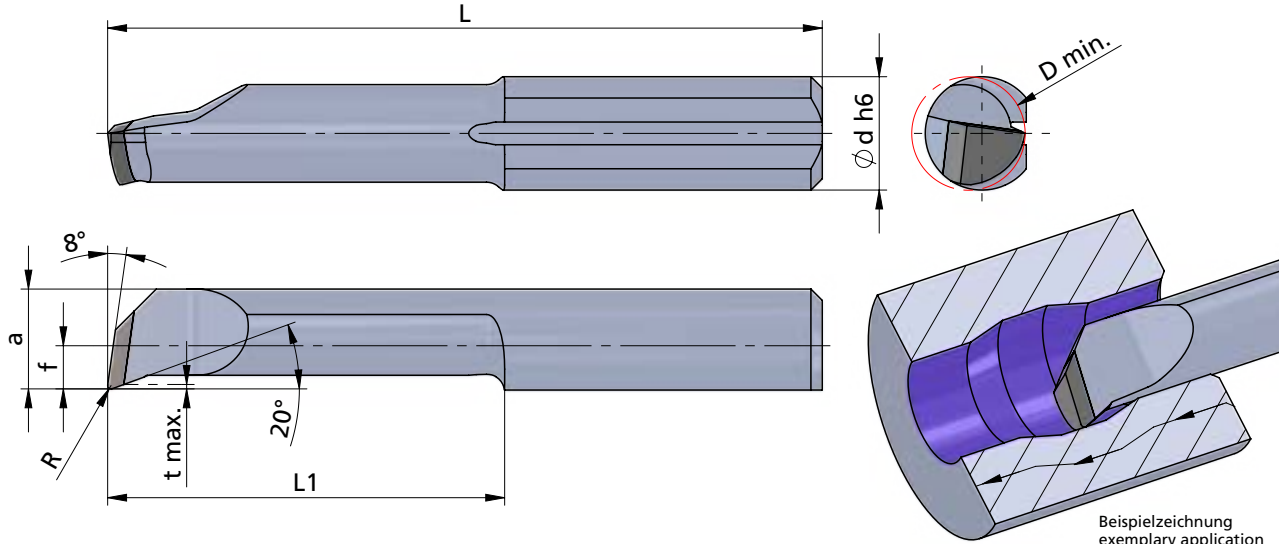

Rechts (R): wie gezeichnet
Links (L): spiegelbildlich

righthand (R): as shown
lefthand version (L): mirror image

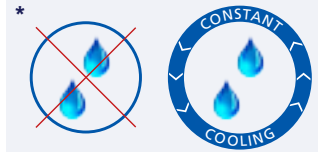

Abmessungen in mm

dimensions in mm

Bestellnummer part number	R	f	a	L	L1	t max.	D min.	Ø d h6	K10F CN45F AL41F CBN	Klemmhalter Typ	toolholder type
R 050.1-5/CBN	0.1	-1.1	0.9	21.5	4.5	0.1	1.0	4.0		645... 640... ...4	
R 050.1-7/CBN	0.1	-1.1	0.9	23.5	6.5	0.1	1.0	4.0			
R 050.15-5/CBN	0.1	-0.7	1.3	20.5	5.0	0.1	1.5	4.0			
R 050.15-10/CBN	0.1	-0.7	1.3	25.5	10	0.1	1.5	4.0			
R 050.2-5/CBN	0.1	-0.3	1.7	20.5	5.0	0.1	2.0	4.0			
R 050.2-10/CBN	0.1	-0.3	1.7	25.5	10	0.1	2.0	4.0			
R 050.2-15/CBN	0.1	-0.3	1.7	30.5	15	0.1	2.0	4.0			
R 050.25-5/CBN	0.1	0.2	2.2	20.5	5.0	0.15	2.5	4.0			
R 050.25-10/CBN	0.1	0.2	2.2	25.5	10	0.15	2.5	4.0			
R 050.25-16/CBN	0.1	0.2	2.2	31.5	16	0.15	2.5	4.0			
R 050.3-10/CBN	0.1	0.6	2.6	25.5	10	0.2	2.8	4.0			
R 050.3-16/CBN	0.1	0.6	2.6	31.5	16	0.2	2.8	4.0			
R 050.3-20/CBN	0.1	0.6	2.6	35.5	20	0.2	2.8	4.0			
↳ ...											

weitere Informationen:

* siehe Technische Hinweise

more informations:

* look at the technical instructions

order-example:

righthand version and grade
R050.1-5/CBN

ULTRAMINI

Bohrungsbearbeitung
ab \varnothing 0.2 mm

grooving, boring and profiling
starting at \varnothing 0.2 mm

Typ 050.../CBN

Ausdrehen und Kopieren,
für Hartbearbeitung

boring and profiling,
for hard machining

D min. 1.0 - 6.8 mm

D min. 1.0 - 6.8 mm

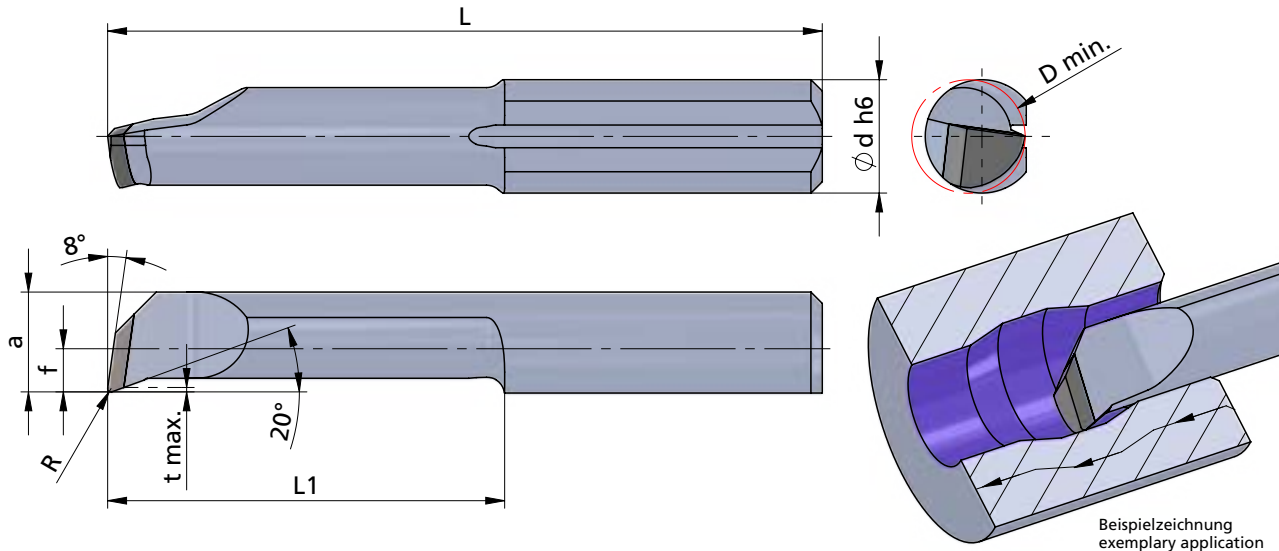

Rechts (R): wie gezeichnet
Links (L): spiegelbildlich

righthand (R): as shown
lefthand version (L): mirror image

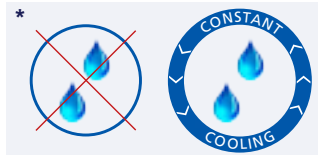

Abmessungen in mm

dimensions in mm

Bestellnummer part number	R	f	a	L	L1	t max.	D min.	\varnothing d h6	K10F CN45F AL41F CBN	Klemmhalter Typ toolholder type
R 050.4-10/CBN	0.10	1.5	3.5	25.5	10	0.3	4.0	4.0	●	645... 640... ...4
R 050.4-16/CBN	0.10	1.5	3.5	31.5	16	0.3	4.0	4.0	●	
R 050.4-20/CBN	0.10	1.5	3.5	35.5	20	0.3	4.0	4.0	●	
R 050.5-10/CBN	0.15	1.9	4.4	26.5	10	0.5	5.0	5.0	●	645... 650... ...5
R 050.5-15/CBN	0.15	1.9	4.4	31.5	15	0.5	5.0	5.0	●	
R 050.5-20/CBN	0.15	1.9	4.4	36.5	20	0.5	5.0	5.0	●	
R 050.5-25/CBN	0.15	1.9	4.4	41.5	25	0.5	5.0	5.0	●	
R 050.5-30/CBN	0.15	1.9	4.4	46.5	30	0.5	5.0	5.0	●	
R 050.6-15/CBN	0.15	2.3	5.3	31.5	15	0.5	6.0	6.0	●	676... 660... ...6
R 050.6-22/CBN	0.15	2.3	5.3	38.5	22	0.5	6.0	6.0	●	
R 050.6-25/CBN	0.15	2.3	5.3	41.5	25	0.5	6.0	6.0	●	
R 050.6-30/CBN	0.15	2.3	5.3	46.5	30	0.5	6.0	6.0	●	
R 050.7-20/CBN	0.15	2.8	6.3	36.5	20	0.6	6.8	7.0	●	670... 687... ...7
R 050.7-25/CBN	0.15	2.8	6.3	41.5	25	0.6	6.8	7.0	●	
R 050.7-30/CBN	0.15	2.8	6.3	46.5	30	0.6	6.8	7.0	●	

Bestellbeispiel:
für rechte Ausführung und Sorte
R050.4-10/CBN

weitere Informationen:
* siehe Technische Hinweise

more informations:
* look at the technical instructions

order-example:
righthand version and grade
R050.4-10/CBN

ULTRAMINI

Bohrungsbearbeitung
ab \varnothing 0.2 mm

grooving, boring and profiling
starting at \varnothing 0.2 mm

Typ 047

Ausdrehen und Kopieren
mit Geometrie $47^\circ / 8^\circ$

boring and profiling
with geometry $47^\circ / 8^\circ$

D min. 2.0 - 6.0 mm

D min. 2.0 - 6.0 mm

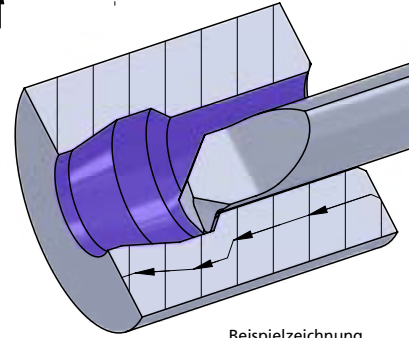
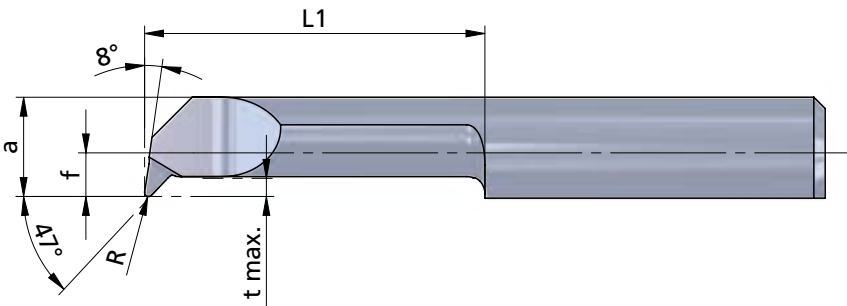
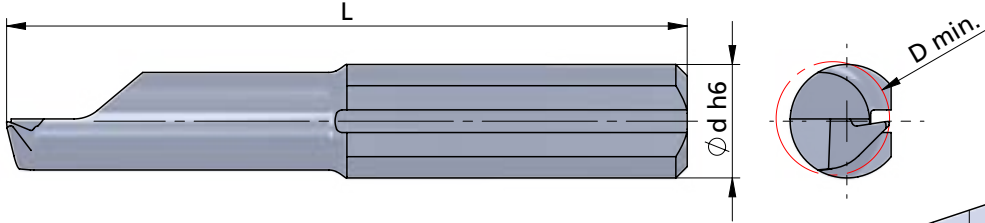
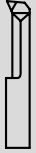

Beispielzeichnung
exemplary application

Rechts (R): wie gezeichnet
Links (L): spiegelbildlich

righthand (R): as shown
lefthand version (L): mirror image

Abmessungen in mm

dimensions in mm

Bestellnummer part number	R	f	a	L	L1	t max.	D min.	Ø d h6	K10F CN45F AL41F P07C	Klemmhalter Typ toolholder type
R/L 047T2-10	0.05	-0.3	1.7	24	10	0.4	2.0	4.0	●	645... 640... ...4
R/L 047T3-15	0.1	0.6	2.6	29	15	0.6	3.0	4.0	●	
R/L 047T4-10	0.1	1.5	3.5	24	10	0.6	4.0	4.0	●	645... 640... ...4
R/L 047.4-20	0.1	1.5	3.5	34	20	0.3	4.0	4.0	●	
R/L 047T4-20	0.1	1.5	3.5	34	20	0.6	4.0	4.0	●	645... 640... ...4
R/L 047T5-15	0.15	1.9	4.4	30	15	0.8	5.0	5.0	●	
R/L 047.5-25	0.15	1.9	4.4	40	25	0.5	5.0	5.0	●	650... ...5
R/L 047T5-25	0.15	1.9	4.4	40	25	0.8	5.0	5.0	●	
R/L 047T6-22	0.15	2.3	5.3	37	22	1.8	6.0	6.0	●	676... 660... ...6
R/L 047.6-30	0.15	2.3	5.3	45	30	0.5	6.0	6.0	●	
R/L 047T6-30	0.15	2.3	5.3	45	30	1.8	6.0	6.0	●	

Weitere HM Sorten können Sie in der Sortenübersicht im Kapitel "Technische Hinweise" und der Preisliste finden.

More carbide grades you can find in the grades summary in the chapter "technical instructions" and in the price list.

ULTRAMINI

Bohrungsbearbeitung
ab \varnothing 0.2 mm

grooving, boring and profiling
starting at \varnothing 0.2 mm

Typ 090

Audreihen und Kopieren
mit Geometrie 20° / 90°

D min. 2.8 - 6.0 mm

boring and profiling
with geometry 20° / 90°

D min. 2.8 - 6.0 mm

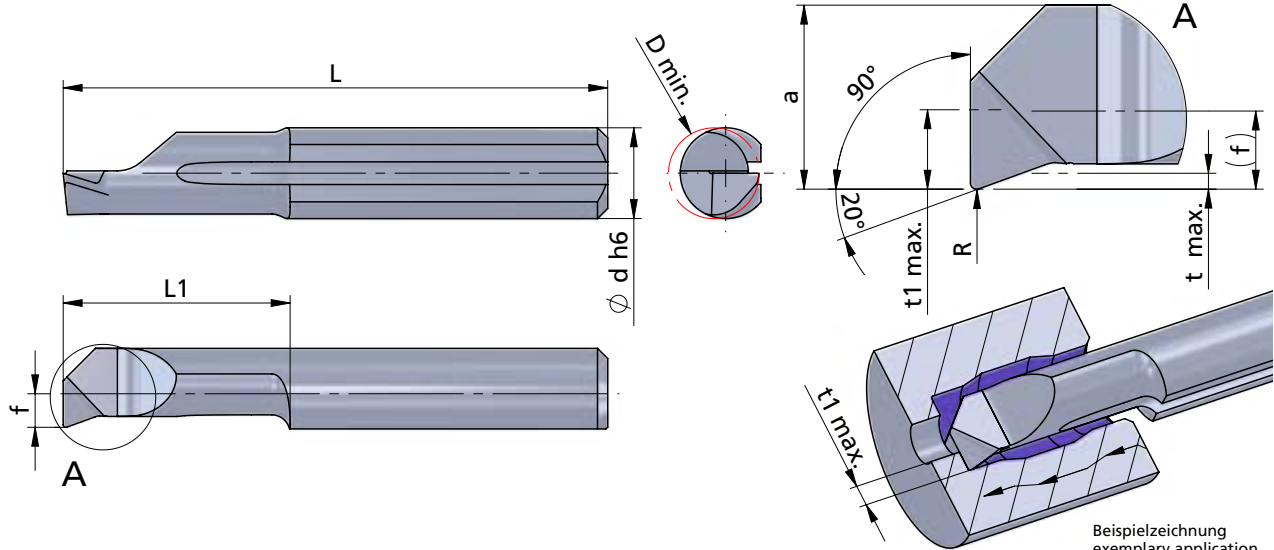

Beispielzeichnung
exemplary application

Rechts (R): wie gezeichnet
Links (L): spiegelbildlich

righthand (R): as shown
lefthand version (L): mirror image

Abmessungen in mm

dimensions in mm

Bestellnummer part number	R	f	a	L	L1	t max.	t1 max.	D min.	Ø d h6	K10F	CN45F	AL41F	P07C	Klemmhalter Typ toolholder type	
															645...
R/L 090.3-10	0.1	0.6	2.6	24	10	0.2	0.8	2.8	4.0	●	●			645...	640... ...4
R/L 090.3-16	0.1	0.6	2.6	30	16	0.2	0.8	2.8	4.0	●	●				
R/L 090.4-10	0.1	1.5	3.5	24	10	0.3	1.5	4.0	4.0	●	●				
R/L 090.4-16	0.1	1.5	3.5	30	16	0.3	1.5	4.0	4.0	●	●				
R/L 090.4-20	0.1	1.5	3.5	34	20	0.3	1.5	4.0	4.0			●			
R/L 090.5-10	0.15	1.9	4.4	25	10	0.5	1.8	5.0	5.0	●	●			645...	650... ...5
R/L 090.5-15	0.15	1.9	4.4	30	15	0.5	1.8	5.0	5.0	●	●				
R/L 090.5-20	0.15	1.9	4.4	35	20	0.5	1.8	5.0	5.0	●	●				
R/L 090.5-25	0.15	1.9	4.4	40	25	0.5	1.8	5.0	5.0			●			
R/L 090.6-15	0.15	2.3	5.3	30	15	0.5	1.8	6.0	6.0			●		676...	660... ...6
R/L 090.6-22	0.15	2.3	5.3	37	22	0.5	1.8	6.0	6.0			●			
R/L 090.6-25	0.15	2.3	5.3	40	25	0.5	1.8	6.0	6.0			●			
R/L 090.6-30	0.15	2.3	5.3	45	30	0.5	1.8	6.0	6.0			●			

Weitere HM Sorten können Sie in der Sortenübersicht im Kapitel "Technische Hinweise" und der Preisliste finden.

More carbide grades you can find in the grades summary in the chapter "technical instructions" and in the price list.

ULTRAMINI

Bohrungsbearbeitung
ab $\varnothing 0.2 \text{ mm}$

grooving, boring and profiling
starting at $\varnothing 0.2 \text{ mm}$

Typ P90

Ausdrehen und Kopieren
mit Geometrie $20^\circ / 90^\circ$
und innerer Kühlmittelzufuhr

boring and profiling
with geometry $20^\circ / 90^\circ$
and through coolant

Performanceline

D min. 2.8 - 5.0 mm

D min. 2.8 - 5.0 mm

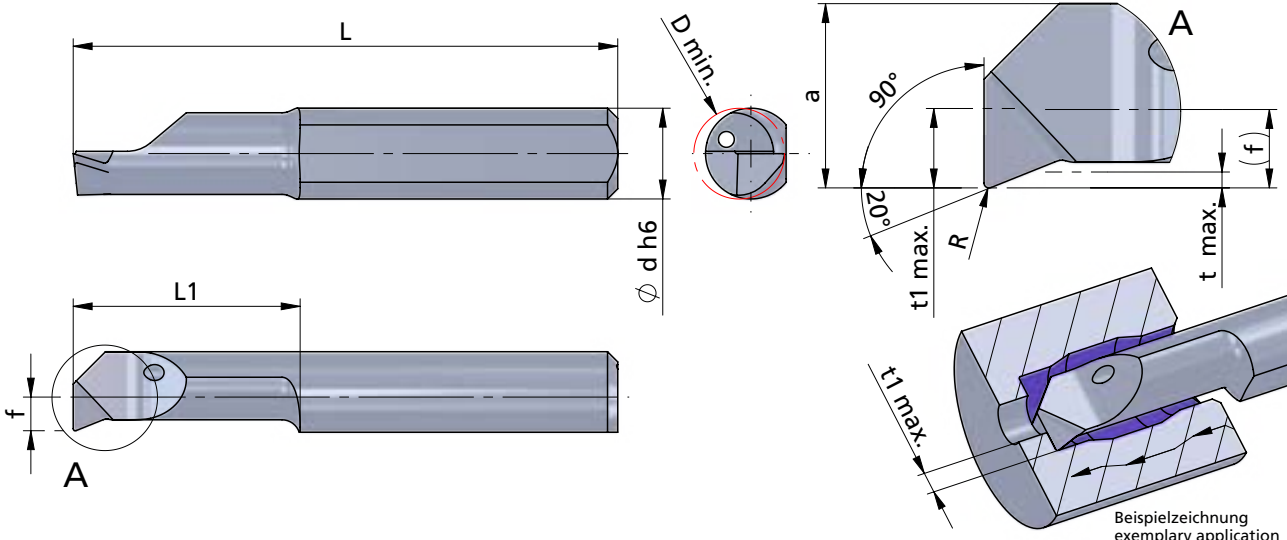

Beispielzeichnung
exemplary application

Rechts (R): wie gezeichnet
Links (L): spiegelbildlich

righthand (R): as shown
lefthand version (L): mirror image



Abmessungen in mm

dimensions in mm

Bestellnummer part number	R	f	a	L	L1	t max.	t1 max.	D min.	$\varnothing d h6$	K10F P04C AL41F P07C	Klemmhalter Typ	toolholder type
											645...	640... ...4 650... ...5
R/L P90.3-10	0.1	0.6	2.6	24	10	0.2	0.8	2.8	4.0	●	645...	640... ...4
R/L P90.3-16	0.1	0.6	2.6	30	16	0.2	0.8	2.8	4.0	●		
R/L P90.4-10	0.1	1.5	3.5	24	10	0.3	1.5	4.0	4.0	●	645...	640... ...4
R/L P90.4-16	0.1	1.5	3.5	30	16	0.3	1.5	4.0	4.0	●		
R/L P90.5-10	0.15	1.9	4.4	25	10	0.5	1.8	5.0	5.0	●	645...	640... ...4 650... ...5
R/L P90.5-15	0.15	1.9	4.4	30	15	0.5	1.8	5.0	5.0	●		
R/L P90.5-20	0.15	1.9	4.4	35	20	0.5	1.8	5.0	5.0	●		

Weitere HM Sorten können Sie in der Sortenübersicht im Kapitel "Technische Hinweise" und der Preisliste finden.

Bestellbeispiel:
für rechte Ausführung und Sorte
RP90.3-10/P04C

More carbide grades you can find in the grades summary in the chapter "technical instructions" and in the price list.

order-example:
righthand version and grade
RP90.3-10/P04C

ULTRAMINI

Bohrungsbearbeitung
ab \varnothing 0.2 mm

grooving, boring and profiling
starting at \varnothing 0.2 mm

Typ DT

Bohren und Ausdrehen

D min. 2.0 - 7.7 mm

drilling and boring

D min. 2.0 - 7.7 mm

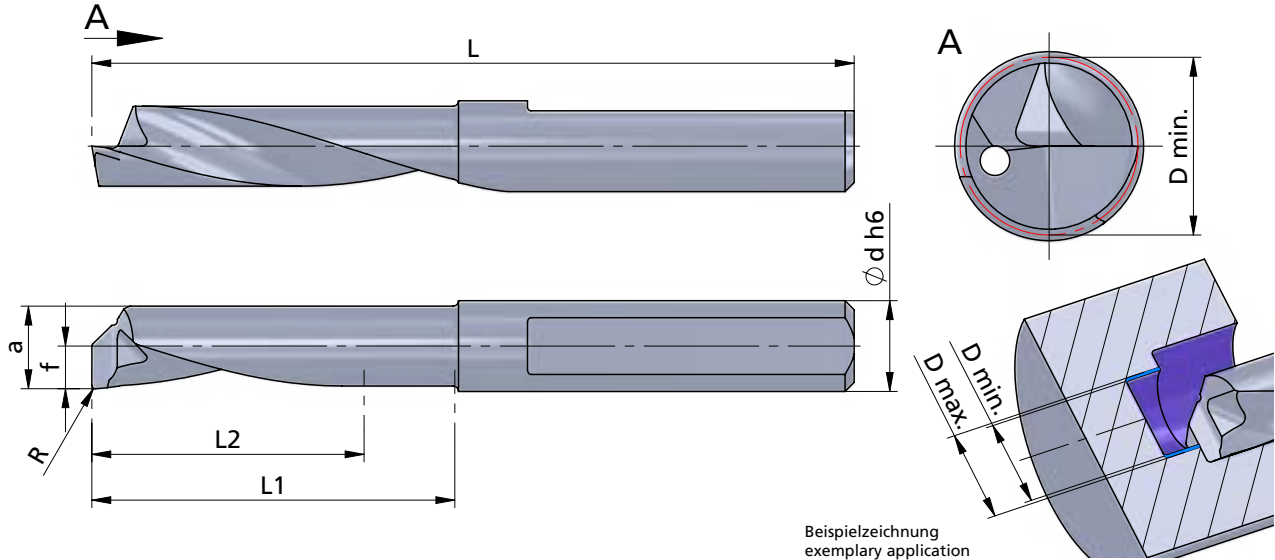

Beispielzeichnung
exemplary application

Rechts (R): wie gezeichnet
Links (L): spiegelbildlich

righthand (R): as shown
lefthand version (L): mirror image

Abmessungen in mm

dimensions in mm



Bestellnummer part number	R	f	a	L	L1 max. Ausdrehtiefe max. boring depth	L2 max. Bohrungstiefe max. drilling depth	D min. (Bohren / drilling)	D max. (Bohren / drilling)	Ø d h6	K10F	CN45F	AL41F	P07C	Klemmhalter Typ toolholder type
R/ DT.2-8R05	0.05	1.0	1.9	40	8	8	2.0	2.0	4			●		640.DT ... 640P.DT ... UM600H...4
R/ DT.2-8R10	0.10	1.0	1.9	40	8	8	2.0	2.0	4			●		
R/ DT.3-10R05	0.05	0.9	2.72	37	10	10	2.9	3.0	4			●		
R/ DT.3-10R10	0.10	0.9	2.72	37	10	10	2.9	3.0	4			●		
R/L DT.3-10	0.20	0.9	2.72	37	10	10	2.9	3.0	4			●		
R/ DT.3-13R05	0.05	0.9	2.72	40	13	13	2.9	3.0	4			●		
R/ DT.3-13R10	0.10	0.9	2.72	40	13	13	2.9	3.0	4			●		
R/L DT.3-13	0.20	0.9	2.72	40	13	13	2.9	3.0	4			●		
R/ DT.4-15R10	0.10	1.85	3.55	37	15	10	3.7	4.0	4			●		
R/L DT.4-15	0.20	1.85	3.55	37	15	10	3.7	4.0	4			●		
R/L DT.4-20	0.20	1.85	3.55	42	20	16	3.7	4.0	4			●		
↳ ...														

Weitere HM Sorten können Sie in der Sortenübersicht im Kapitel "Technische Hinweise" und der Preisliste finden.

weitere Informationen:

- siehe Technische Hinweise

More carbide grades you can find in the grades summary in the chapter "technical instructions" and in the price list.

more informations:

- look at the Technical Instructions

order-example:
righthand version and grade
RDT.2-8R05/AL41F

Bestellbeispiel:
für rechte Ausführung und Sorte
RDT.2-8R05/AL41F

ULTRAMINI

Bohrungsbearbeitung
ab $\varnothing 0.2 \text{ mm}$

grooving, boring and profiling
starting at $\varnothing 0.2 \text{ mm}$

Typ DT

Bohren und Ausdrehen

D min. 2.0 - 7.7 mm

drilling and boring

D min. 2.0 - 7.7 mm

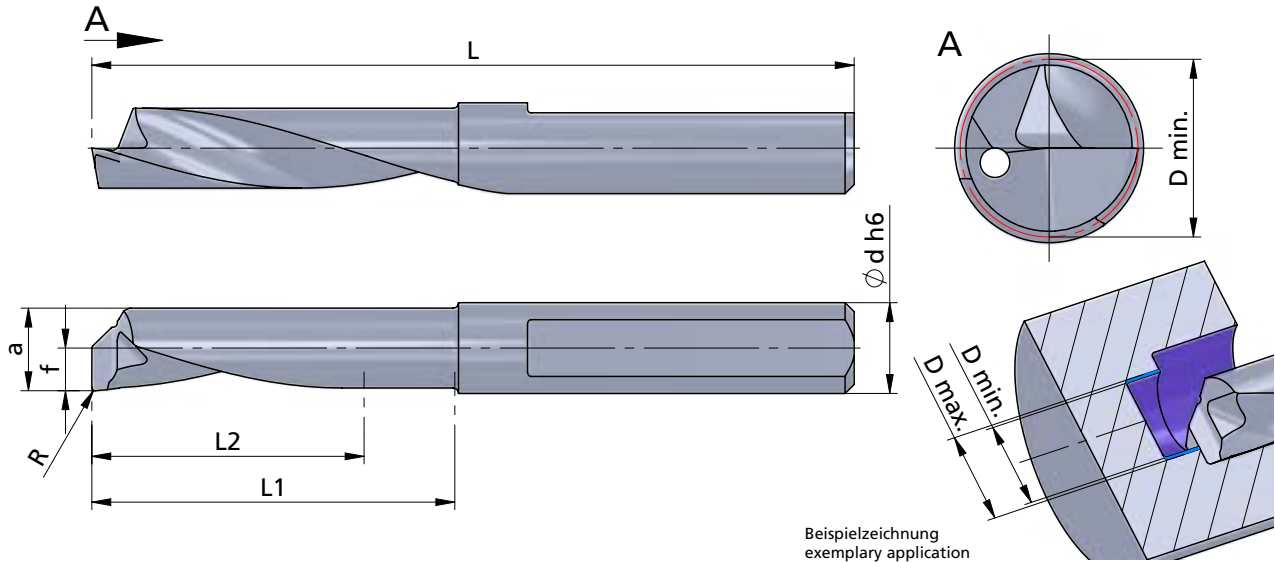

Beispielzeichnung
exemplary application

Rechts (R): wie gezeichnet
Links (L): spiegelbildlich

righthand (R): as shown
lefthand version (L): mirror image



Abmessungen in mm

dimensions in mm

Bestellnummer part number	R	f	a	L	L1 max. Ausdrehtiefe max. boring depth	L2 max. Bohrungstiefe max. drilling depth	D min. (Bohren / drilling)	D max. (Bohren / drilling)	$\varnothing d \text{ h6}$	K10F CN45F AL41F P07C	Klemmhalter Typ toolholder type	
... ↘												
R/ DT.5-15R10	0.10	2.35	4.55	37	15	10	4.7	5.0	5	●		
R/L DT.5-15	0.20	2.35	4.55	37	15	10	4.7	5.0	5	●		650.DT ... 650P.DT ... UM600H...5
R/ DT.5-20R10	0.10	2.35	4.55	42	20	15	4.7	5.0	5	●		
R/L DT.5-20	0.20	2.35	4.55	42	20	15	4.7	5.0	5	●		
R/L DT.5-25	0.20	2.35	4.55	47	25	20	4.7	5.0	5	●		
R/ DT.6-15R10	0.10	2.85	5.55	37	15	10	5.7	6.0	6	●		
R/L DT.6-15	0.20	2.85	5.55	37	15	10	5.7	6.0	6	●		
R/ DT.6-20R10	0.10	2.85	5.55	42	20	15	5.7	6.0	6	●		
R/L DT.6-20	0.20	2.85	5.55	42	20	15	5.7	6.0	6	●		660.DT ... 660P.DT ... UM600H...6
R/L DT.6-25	0.20	2.85	5.55	47	25	20	5.7	6.0	6	●		
R/L DT.6-30	0.20	2.85	5.55	52	30	25	5.7	6.0	6	●		
↳ ...												

Weitere HM Sorten können Sie in der Sortenübersicht im Kapitel "Technische Hinweise" und der Preisliste finden.

Bestellbeispiel:
für rechte Ausführung und Sorte
RDT.5-15R10/AL41F

weitere Informationen:

- siehe Technische Hinweise

more informations:

- look at the Technical Instructions

More carbide grades you can find in the grades summary in the chapter "technical instructions" and in the price list.

order-example:
righthand version and grade
RDT.5-15R10/AL41F

ULTRAMINI

Bohrungsbearbeitung
ab $\varnothing 0.2$ mm

grooving, boring and profiling
starting at $\varnothing 0.2$ mm

Typ DT

Bohren und Ausdrehen

D min. 2.0 - 7.7 mm

drilling and boring

D min. 2.0 - 7.7 mm

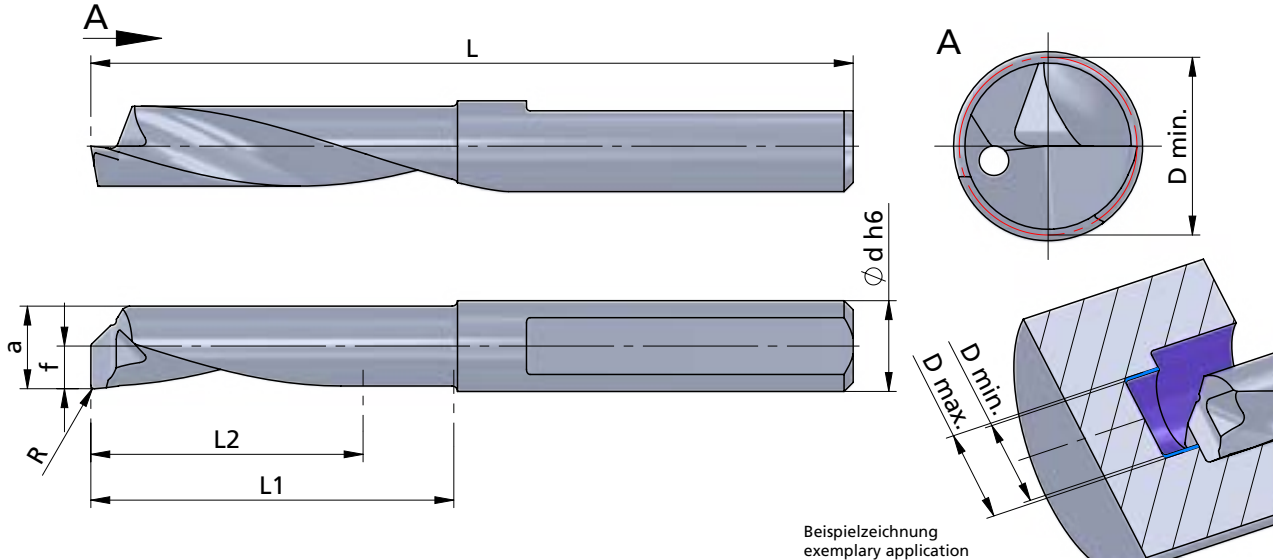

Beispielzeichnung
exemplary application

Rechts (R): wie gezeichnet
Links (L): spiegelbildlich

righthand (R): as shown
lefthand version (L): mirror image

Abmessungen in mm

dimensions in mm



Bestellnummer part number	R	f	a	L	L1 max. Ausdrehtiefe max. boring depth	L2 max. Bohrungstiefe max. drilling depth	D min. (Bohren / drilling)	D max. (Bohren / drilling)	$\varnothing d h6$	K10F CN45F AL41F P07C	Klemmhalter Typ toolholder type
R/L DT.7-20	0.2	3.35	6.55	42	20	15	6.7	7.0	7	●	670.DT ... 670P.DT ... UM600H...7
R/L DT.7-25	0.2	3.35	6.55	47	25	20	6.7	7.0	7	●	
R/L DT.7-30	0.2	3.35	6.55	52	30	25	6.7	7.0	7	●	
R/L DT.7-35	0.2	3.35	6.55	57	35	30	6.7	7.0	7	●	
R/L DT.8-25	0.2	3.85	7.55	50	25	20	7.7	8.0	8	●	680.DT ... 680P.DT ...
R/L DT.8-30	0.2	3.85	7.55	55	30	25	7.7	8.0	8	●	
R/L DT.8-35	0.2	3.85	7.55	60	35	30	7.7	8.0	8	●	
R/L DT.8-40	0.2	3.85	7.55	65	40	35	7.7	8.0	8	●	

Weitere HM Sorten können Sie in der Sortenübersicht im Kapitel "Technische Hinweise" und der Preisliste finden.

weitere Informationen:
• siehe Technische Hinweise

More carbide grades you can find in the grades summary in the chapter "technical instructions" and in the price list.

Bestellbeispiel:
für rechte Ausführung und Sorte
RDT.7-20/AL41F

more informations:
• look at the Technical Instructions

order-example:
righthand version and grade
RDT.7-20/AL41F

ULTRAMINI

Bohrungsbearbeitung
ab $\varnothing 0.2$ mm

grooving, boring and profiling
starting at $\varnothing 0.2$ mm

Typ 080

Rückwärtsdrehen

D min. 3.0 - 7.0 mm

backboring

D min. 3.0 - 7.0 mm

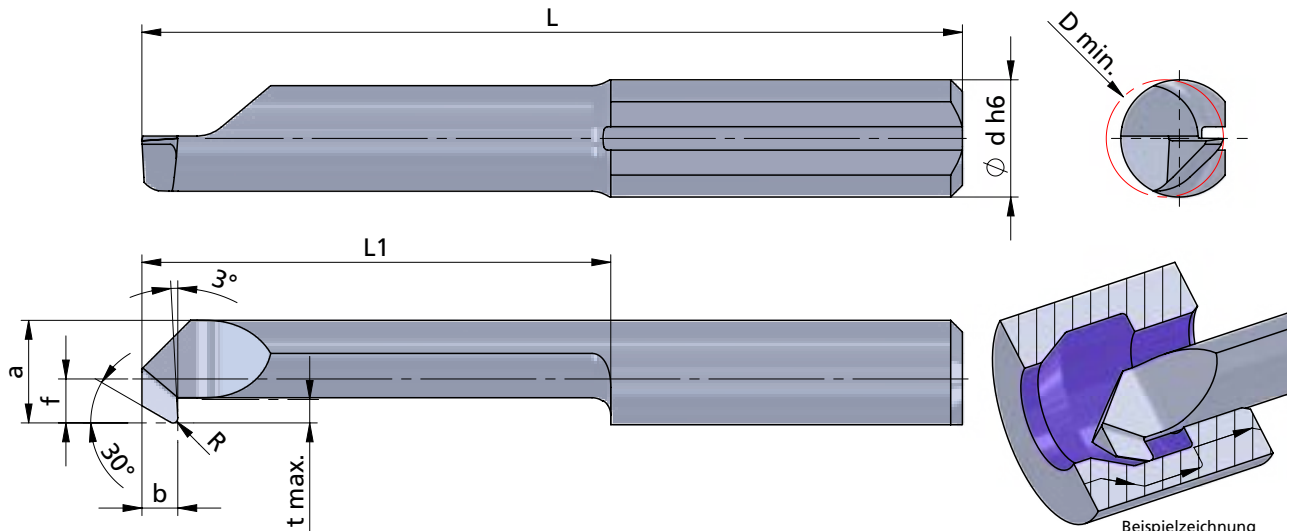

Rechts (R): wie gezeichnet
Links (L): spiegelbildlich

righthand (R): as shown
lefthand version (L): mirror image

Abmessungen in mm

dimensions in mm

Bestellnummer part number	b	R	f	a	L	L1	t max.	D min.	Ø d h6	Klemhalter Typ				Klemhalter Typ	toolholder type
										K10F	CN45F	AL41F	PD2F		
R/L 080.0003-15	1.5	0.1	0.6	2.6	30	15	0.5	3.0	4.0	●	●			645... 640... ...4	In Kombination mit UM600H... muss mit Schlüssel gespannt werden! In combination with UM600H... you have to clamp with wrench!
R/L 080.0003-20	1.5	0.1	0.6	2.6	34	20	0.5	3.0	4.0	●	●				
R/L 080.0004-15	1.5	0.15	1.5	3.5	30	15	0.8	4.0	4.0	●	●				
R/L 080.0004-25	1.5	0.15	1.5	3.5	39	25	0.8	4.0	4.0	●	●				
R/L 080.0005-20	1.5	0.2	1.9	4.4	35	20	1.0	5.0	5.0	●	●				
R/L 080.0005-30	1.5	0.2	1.9	4.4	45	30	1.0	5.0	5.0	●	●				
R/L 080.0006-20	1.5	0.2	2.3	5.3	35	20	1.8	6.0	6.0	●	●				
R/L 080.0006-30	1.5	0.2	2.3	5.3	45	30	1.8	6.0	6.0	●	●				
R/L 080.0007-20	1.5	0.2	2.8	6.3	35	20	2.5	7.0	7.0	●	●				
R/L 080.0007-30	1.5	0.2	2.8	6.3	45	30	2.5	7.0	7.0	●	●				

Weitere HM Sorten können Sie in der Sortenübersicht im Kapitel "Technische Hinweise" und der Preisliste finden.

Bestellbeispiel:
für rechte Ausführung und Sorte
R080.0003-15/AL41F

More carbide grades you can find in the grades summary in the chapter "technical instructions" and in the price list.

order-example:
righthand version and grade
R080.0003-15/AL41F

ULTRAMINI

Bohrungsbearbeitung
ab Ø 0.2 mm

grooving, boring and profiling
starting at Ø 0.2 mm

Typ P80

Rückwärtsdrehen
mit innerer Kühlmittelzufuhr

backboring
with through coolant

Performanceline

D min. 3.0 - 7.0 mm

D min. 3.0 - 7.0 mm

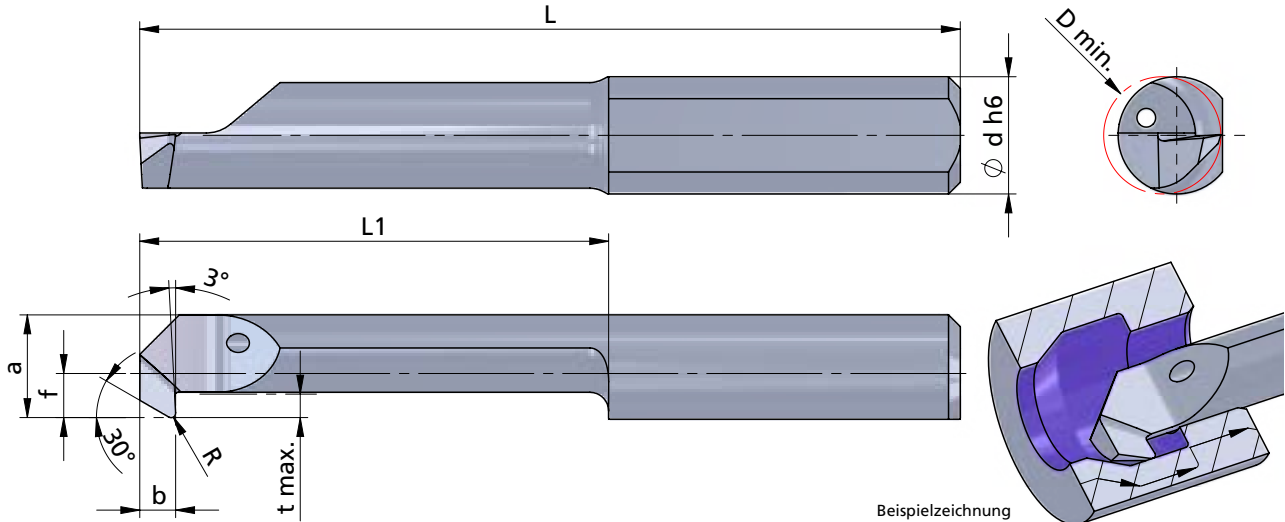

Rechts (R): wie gezeichnet
Links (L): spiegelbildlich

righthand (R): as shown
lefthand version (L): mirror image

Abmessungen in mm

dimensions in mm



Bestellnummer part number	b	R	f	a	L	L1	t max.	D min.	Ø d h6	K10F	P04C	AL41F	PD2F	Klemhalter Typ toolholder type	
														645...	640... ...4
R/L P80.0003-15	1.5	0.1	0.6	2.6	30	15	0.5	3.0	4.0	●				645...	640... ...4
R/L P80.0003-20	1.5	0.1	0.6	2.6	34	20	0.5	3.0	4.0	●					
R/L P80.0004-15	1.5	0.15	1.5	3.5	30	15	0.8	4.0	4.0	●				645...	650... ...5
R/L P80.0004-25	1.5	0.15	1.5	3.5	39	25	0.8	4.0	4.0	●					
R/L P80.0005-20	1.5	0.2	1.9	4.4	35	20	1.0	5.0	5.0	●				645...	650... ...5
R/L P80.0005-30	1.5	0.2	1.9	4.4	45	30	1.0	5.0	5.0	●					
R/L P80.0006-20	1.5	0.2	2.3	5.3	35	20	1.8	6.0	6.0	●				676...	660... ...6
R/L P80.0006-30	1.5	0.2	2.3	5.3	45	30	1.8	6.0	6.0	●					
R/L P80.0007-20	1.5	0.2	2.8	6.3	35	20	2.5	7.0	7.0	●				676...	670... 687... ...7
R/L P80.0007-30	1.5	0.2	2.8	6.3	45	30	2.5	7.0	7.0	●					

In Kombination mit UM600H... muss
mit Schlüssel gespannt werden!
In combination with UM600H... you
have to clamp with wrench!

Weitere HM Sorten können Sie in der Sorten-
übersicht im Kapitel "Technische Hinweise" und
der Preisliste finden.

More carbide grades you can find in the grades
summary in the chapter "technical instructions"
and in the price list.

ULTRAMINI

Bohrungsbearbeitung
ab \varnothing 0.2 mm

grooving, boring and profiling
starting at \varnothing 0.2 mm

Impressionen

impressions

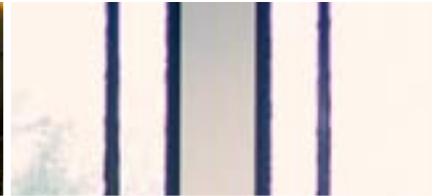

ULTRAMINI

Bohrungsbearbeitung
ab $\varnothing 0.2$ mm

grooving, boring and profiling
starting at $\varnothing 0.2$ mm

Typ 001 / 0015

Stechdrehen

D min. 1.0 / 1.5 mm
Stechtiefe t max. 0.2 / 0.4 mm

grooving

D min. 1.0 / 1.5 mm
depth of groove t max. 0.2 / 0.4 mm

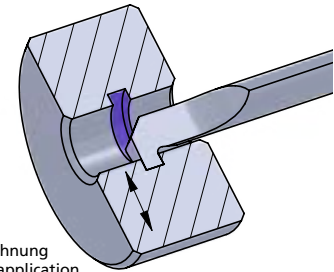
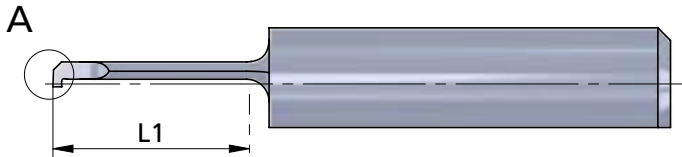
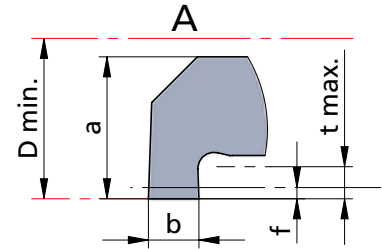
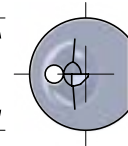
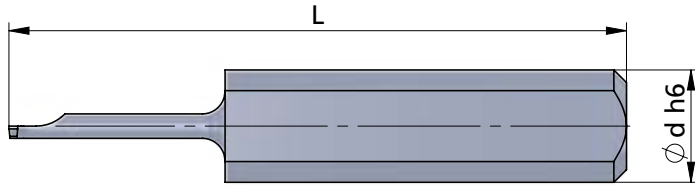

Beispielzeichnung
exemplary application

Rechts (R): wie gezeichnet
Links (L): spiegelbildlich

righthand (R): as shown
lefthand version (L): mirror image



Abmessungen in mm

dimensions in mm

Bestellnummer part number	b +0.03	a	f	L	L1	t max.	D min.	Ø d h6	K10F CN45F AL41F P07C	Klemmhalter Typ	toolholder type
R/L 001.0030-4	0.3	0.9	0.1	20	4	0.2	1.0	4.0			
R/L 001.0030-7	0.3	0.9	0.1	22	7	0.2	1.0	4.0			
R/L 0015.0040-5	0.4	1.4	0.6	22	5	0.4	1.5	4.0			640... 645... ...4
R/L 0015.0040-10	0.4	1.4	0.6	25	10	0.4	1.5	4.0			
R/L 0015.0040-12	0.4	1.4	0.6	27	12	0.4	1.5	4.0			

Weitere HM Sorten können Sie in der Sortenübersicht im Kapitel "Technische Hinweise" und der Preisliste finden.

More carbide grades you can find in the grades summary in the chapter "technical instructions" and in the price list.

Bestellbeispiel:
für rechte Ausführung und Sorte
R001.0030-4/AL41F

order-example:
righthand version and grade
R001.0030-4/AL41F

ULTRAMINI

Bohrungsbearbeitung
ab $\varnothing 0.2 \text{ mm}$

grooving, boring and profiling
starting at $\varnothing 0.2 \text{ mm}$

Typ 002

Stechdrehen

grooving

D min. 2.0 mm
Stechtiefe t max. 0.4 mm

D min. 2.0 mm
depth of groove t max. 0.4 mm

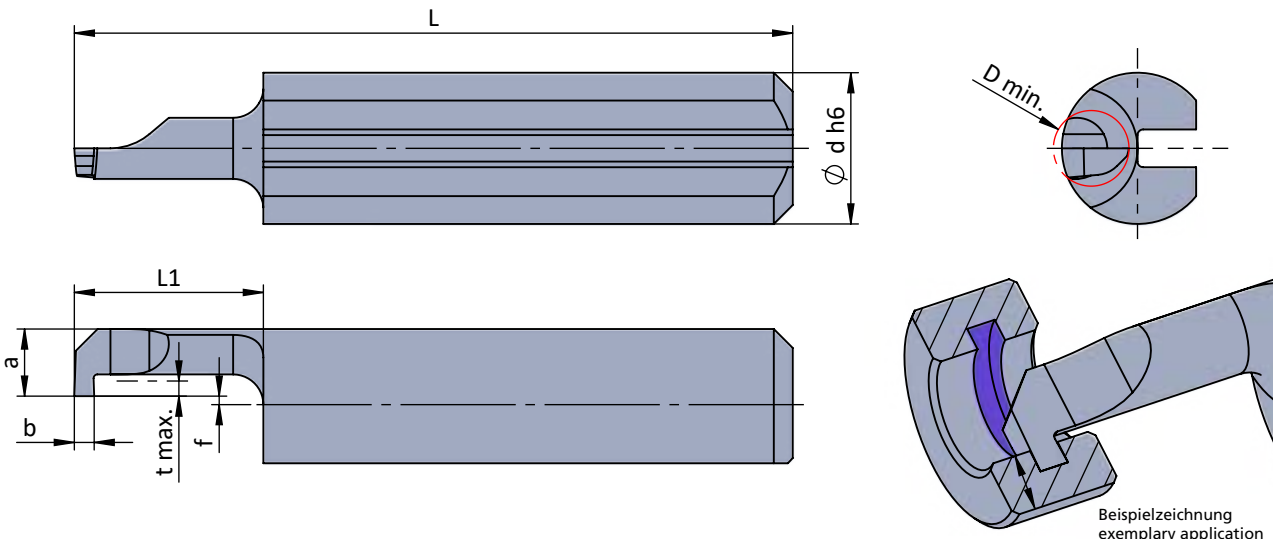

Rechts (R): wie gezeichnet
Links (L): spiegelbildlich

righthand (R): as shown
lefthand version (L): mirror image

Abmessungen in mm

dimensions in mm

Bestellnummer part number	b +0.05	a	f	L	L1	t max.	D min.	$\varnothing d h6$	K10F CN45F AL41F P07C	Klemmhalter Typ	toolholder type
R/L 002.0050-5	0.5	1.8	-0.2	19	5	0.4	2.0	4.0			
R/L 002.0050-10	0.5	1.8	-0.2	24	10	0.4	2.0	4.0			640... 645... ...4
R/L 002.0050-15	0.5	1.8	-0.2	29	15	0.4	2.0	4.0			

Weitere HM Sorten können Sie in der Sortenübersicht im Kapitel "Technische Hinweise" und der Preisliste finden.

Bestellbeispiel:
für rechte Ausführung und Sorte
R002.0050-5/AL41F

More carbide grades you can find in the grades summary in the chapter "technical instructions" and in the price list.

order-example:
righthand version and grade
R002.0050-5/AL41F

ULTRAMINI

Bohrungsbearbeitung
ab \varnothing 0.2 mm

grooving, boring and profiling
starting at \varnothing 0.2 mm

Typ 003

Stechdrehen

D min. 3.0 mm
Stechtiefe t max. 0.6 mm

grooving

D min. 3.0 mm
depth of groove t max. 0.6 mm

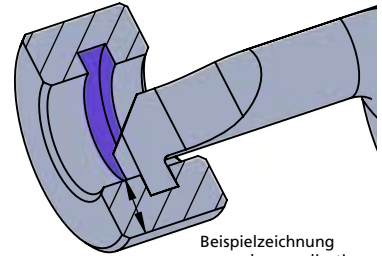
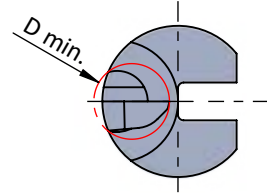
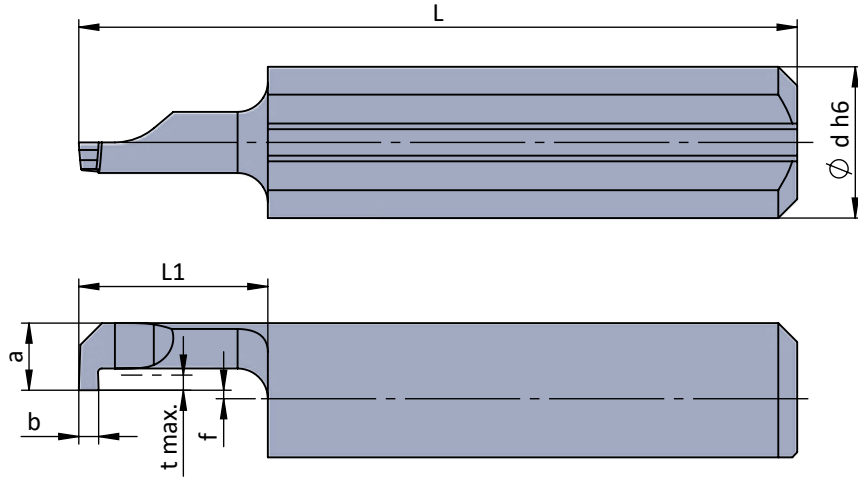

Beispielzeichnung
exemplary application

Rechts (R): wie gezeichnet
Links (L): spiegelbildlich

righthand (R): as shown
lefthand version (L): mirror image

Abmessungen in mm

dimensions in mm

Bestellnummer part number	b +0.05	f	a	L	L1	t max.	D min.	\varnothing d h6	Klemmhalter Typ toolholder type				
									K10F	CN45F	AL41F	P07C	
R/L 003.0070-5	0.7	-0.7	2.7	19	5	0.6	3.0	4.0					
R/L 003.0070-10	0.7	-0.7	2.7	24	10	0.6	3.0	4.0					640... 645... ...4
R/L 003.0070-16	0.7	-0.7	2.7	30	16	0.6	3.0	4.0					

Weitere HM Sorten können Sie in der Sortenübersicht im Kapitel "Technische Hinweise" und der Preisliste finden.

More carbide grades you can find in the grades summary in the chapter "technical instructions" and in the price list.

Bestellbeispiel:
für rechte Ausführung und Sorte
R003.0070-5/AL41F

order-example:
righthand version and grade
R003.0070-5/AL41F

ULTRAMINI

Bohrungsbearbeitung
ab \varnothing 0.2 mm

grooving, boring and profiling
starting at \varnothing 0.2 mm

Typ 004

Stechdrehen

D min. 4.0 mm
Stechtiefe t max. 0.8 mm

grooving

D min. 4.0 mm
depth of groove t max. 0.8 mm

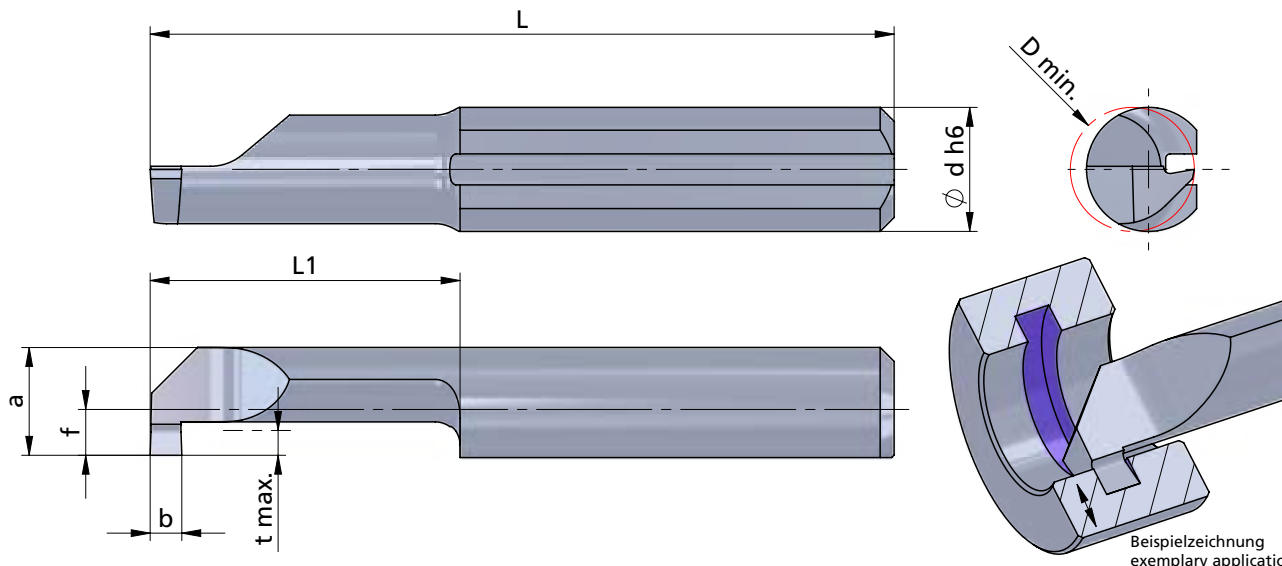

Rechts (R): wie gezeichnet
Links (L): spiegelbildlich

righthand (R): as shown
lefthand version (L): mirror image

Abmessungen in mm

dimensions in mm

Bestellnummer part number	b +0.05	f	a	L	L1	t max.	D min.	\varnothing d h6					Klemmhalter Typ toolholder type
									K10F	CN45F	AL41F	P07C	
R/L 004.0050-10	0.5	1.5	3.5	24	10	0.8	4.0	4.0					640... 645... ...4
R/L 004.0050-16	0.5	1.5	3.5	30	16	0.8	4.0	4.0					
R/L 004.0050-20	0.5	1.5	3.5	34	20	0.8	4.0	4.0					
R/L 004.0100-10	1.0	1.5	3.5	24	10	0.8	4.0	4.0	●	●	●		
R/L 004.0100-16	1.0	1.5	3.5	30	16	0.8	4.0	4.0	●	●	●		
R/L 004.0100-20	1.0	1.5	3.5	34	20	0.8	4.0	4.0	●	●	●		

Weitere HM Sorten können Sie in der Sortenübersicht im Kapitel "Technische Hinweise" und der Preisliste finden.

Bestellbeispiel:
für rechte Ausführung und Sorte
R004.0050-10/AL41F

More carbide grades you can find in the grades summary in the chapter "technical instructions" and in the price list.

order-example:
righthand version and grade
R004.0050-10/AL41F

ULTRAMINI

Bohrungsbearbeitung
ab $\varnothing 0.2$ mm

grooving, boring and profiling
starting at $\varnothing 0.2$ mm

Typ 004M

Stechdrehen
mit Eckenradius

grooving
with corner radius

D min. 4.0 mm
Stechtiefe t max. 0.8 mm

D min. 4.0 mm
depth of groove t max. 0.8 mm

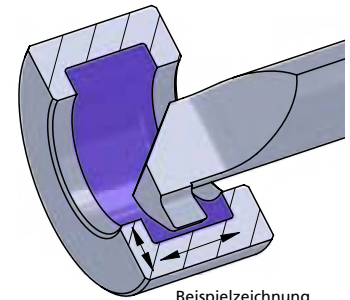
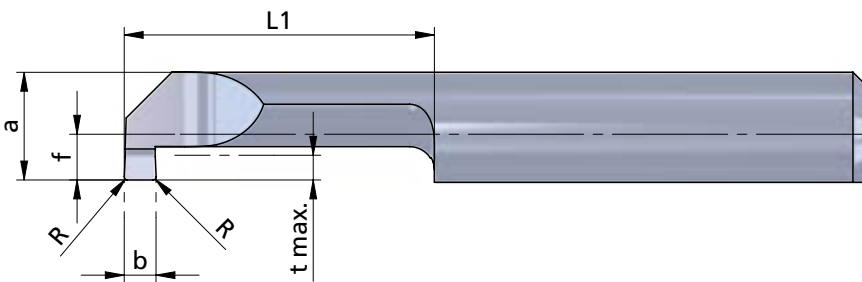
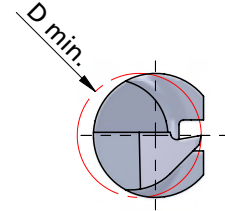
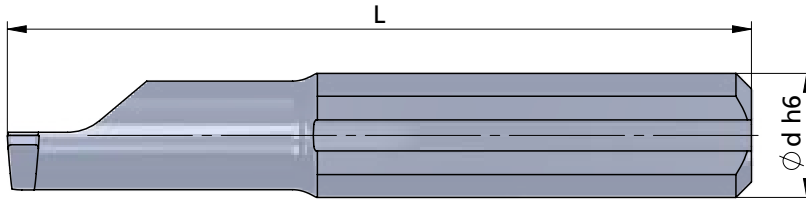

Beispielzeichnung
exemplary application

Rechts (R): wie gezeichnet
Links (L): spiegelbildlich

righthand (R): as shown
lefthand version (L): mirror image

Abmessungen in mm

dimensions in mm

Bestellnummer part number	b +0.05	b (inch)	R	f	a	L	L1	t max.	D min.	Ø d h6	Klemmhalter Typ toolholder type				
											K10F	CN45F	AL41F	P07C	
R/L 004M0079-20	0.79	0.031"	0.1	1.5	3.5	34	20	0.8	4.0	4.0	●				
R/L 004M0100-10	1.0		0.1	1.5	3.5	24	10	0.8	4.0	4.0		●			640... 645... ...4
R/L 004M0100-16	1.0		0.1	1.5	3.5	30	16	0.8	4.0	4.0		●			
R/L 004M0100-20	1.0		0.1	1.5	3.5	34	20	0.8	4.0	4.0		●			

Weitere HM Sorten können Sie in der Sortenübersicht im Kapitel "Technische Hinweise" und der Preisliste finden.

More carbide grades you can find in the grades summary in the chapter "technical instructions" and in the price list.

Bestellbeispiel:
für rechte Ausführung und Sorte
R004M0079-20/AL41F

order-example:
righthand version and grade
R004M0079-20/AL41F

ULTRAMINI

Bohrungsbearbeitung
ab \varnothing 0.2 mm

grooving, boring and profiling
starting at \varnothing 0.2 mm

Typ P04M

Stechdrehen
mit Eckenradius
und innerer Kühlmittelzufuhr

grooving
with corner radius
and through coolant

Performanceline

D min. 4.0 mm
Stechtiefe t max. 0.8 mm

D min. 4.0 mm
depth of groove t max. 0.8 mm

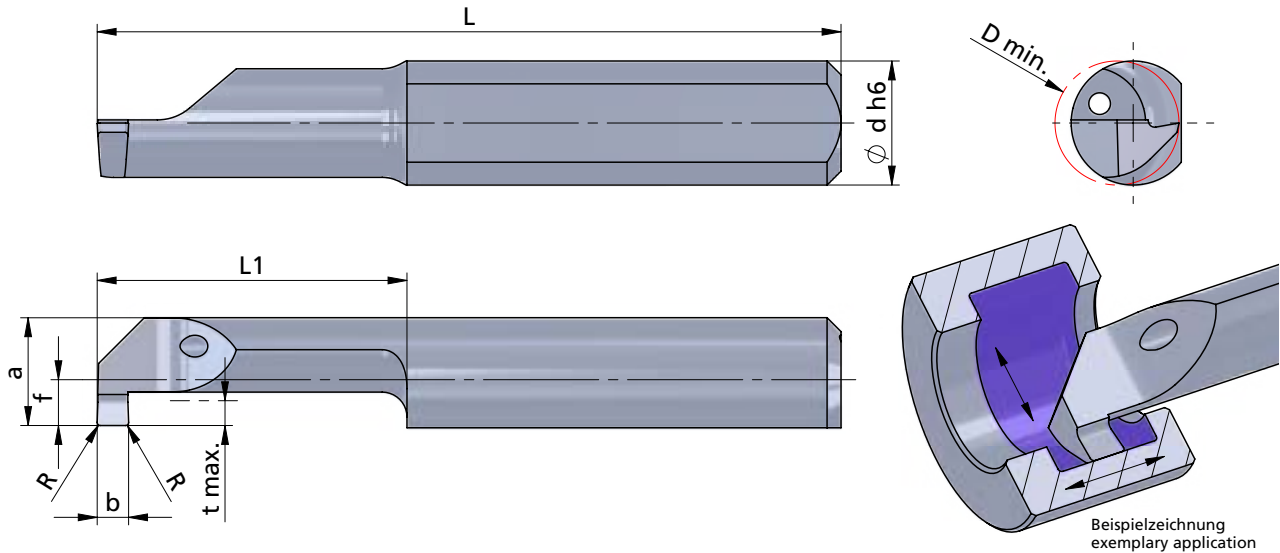

Rechts (R): wie gezeichnet
Links (L): spiegelbildlich

righthand (R): as shown
lefthand version (L): mirror image

Abmessungen in mm

dimensions in mm



Bestellnummer part number	b +0.05	b (inch)	R	f	a	L	L1	t max.	D min.	Ø d h6	Klemmhalter Typ toolholder type				
											K10F	P04C	AL41F	P07C	
R/L P04M0079-20	0.79	0.031"	0.1	1.5	3.5	34	20	0.8	4.0	4.0	●				
R/L P04M0100-10	1.0		0.1	1.5	3.5	24	10	0.8	4.0	4.0	●				
R/L P04M0100-16	1.0		0.1	1.5	3.5	30	16	0.8	4.0	4.0	●				640... 645... ...4
R/L P04M0100-20	1.0		0.1	1.5	3.5	34	20	0.8	4.0	4.0	●				

Weitere HM Sorten können Sie in der Sortenübersicht im Kapitel "Technische Hinweise" und der Preisliste finden.

Bestellbeispiel:
für rechte Ausführung und Sorte
RP04M0079-20/P04C

More carbide grades you can find in the grades summary in the chapter "technical instructions" and in the price list.

order-example:
righthand version and grade
RP04M0079-20/P04C

ULTRAMINI

Bohrungsbearbeitung
ab Ø 0.2 mm

grooving, boring and profiling
starting at Ø 0.2 mm

Typ 005

Stechdrehen

grooving

D min. 5.0 mm
Stechtiefe t max. 1.0 mm
Auskragung (L1) bis 7x D

D min. 5.0 mm
depth of groove t max. 1.0 mm
overhang length (L1) up to 7x D

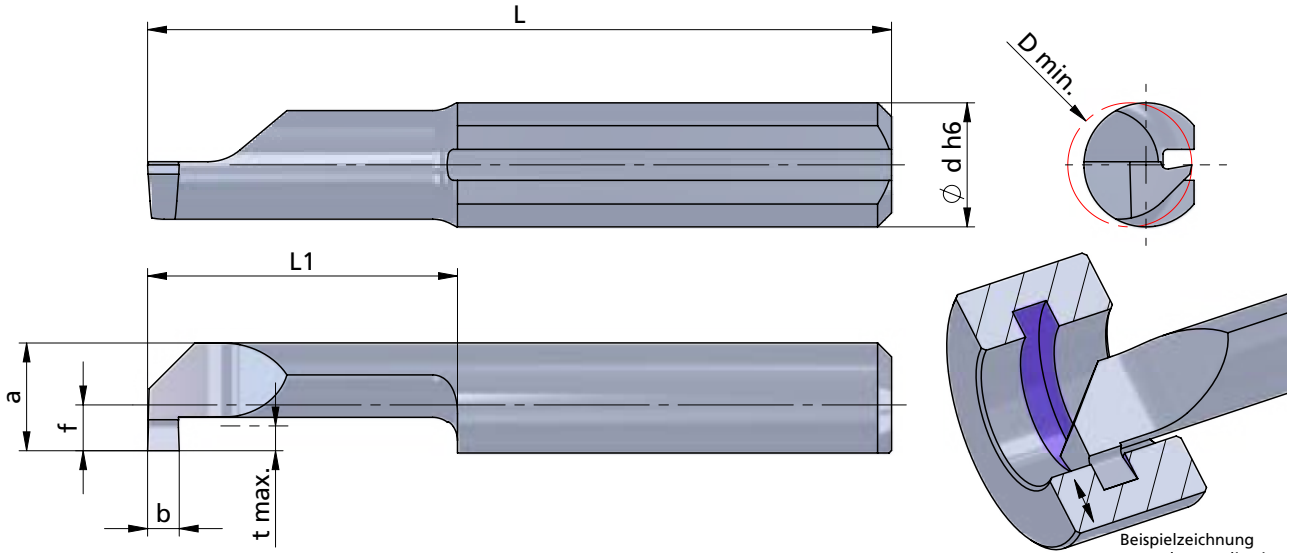
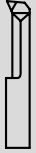

Rechts (R): wie gezeichnet
Links (L): spiegelbildlich

righthand (R): as shown
lefthand version (L): mirror image

Abmessungen in mm

dimensions in mm

Bestellnummer part number	b +0.05	b (inch)	f	a	L	L1	t max.	D min.	Ø d h6	K10F CN45F AL41F P07C	Klemmhalter Typ toolholder type
	R/L 005.0100-10	1.0		1.9	4.4	25	10	1.0	5.0		
R/L 005.0100-15	1.0		1.9	4.4	30	15	1.0	5.0	5.0	● ● ●	
R/L 005.0100-20	1.0		1.9	4.4	35	20	1.0	5.0	5.0	● ● ●	
R/L 005.0100-25	1.0		1.9	4.4	40	25	1.0	5.0	5.0	● ● ●	
R/L 005.0100-30	1.0		1.9	4.4	45	30	1.0	5.0	5.0	● ● ●	
R/L 005.0100-35	1.0		1.9	4.4	50	35	1.0	5.0	5.0	● ● ●	
R/L 005.0117-30	1.17	0.046"	1.9	4.4	45	30	1.0	5.0	5.0	● ● ●	
R/L 005.0150-10	1.5		1.9	4.4	25	10	1.0	5.0	5.0	● ● ●	
R/L 005.0150-15	1.5		1.9	4.4	30	15	1.0	5.0	5.0	● ● ●	
R/L 005.0150-20	1.5		1.9	4.4	35	20	1.0	5.0	5.0	● ● ●	
R/L 005.0150-25	1.5		1.9	4.4	40	25	1.0	5.0	5.0	● ● ●	
R/L 005.0150-30	1.5		1.9	4.4	45	30	1.0	5.0	5.0	● ● ●	
↳ ...											

Weitere HM Sorten können Sie in der Sortenübersicht im Kapitel "Technische Hinweise" und der Preisliste finden.

More carbide grades you can find in the grades summary in the chapter "technical instructions" and in the price list.

Bestellbeispiel:
für rechte Ausführung und Sorte
R005.0100-10/AL41F

order-example:
righthand version and grade
R005.0100-10/AL41F

ULTRAMINI

Bohrungsbearbeitung
ab $\varnothing 0.2 \text{ mm}$

grooving, boring and profiling
starting at $\varnothing 0.2 \text{ mm}$

Typ 005

Stechdrehen

grooving

D min. 5.0 mm
Stechtiefe t max. 1.0 mm
Auskragung (L1) bis 7x D

D min. 5.0 mm
depth of groove t max. 1.0 mm
overhang length (L1) up to 7x D

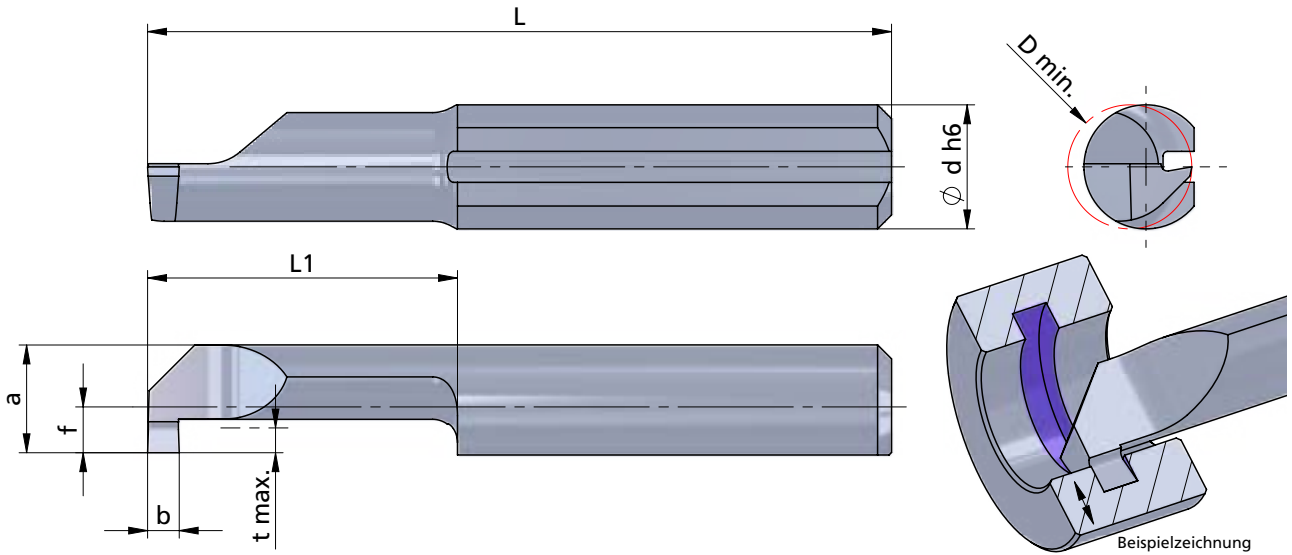

Rechts (R): wie gezeichnet
Links (L): spiegelbildlich

righthand (R): as shown
lefthand version (L): mirror image

Abmessungen in mm

dimensions in mm

Bestellnummer part number	b +0.05	b (inch)	f	a	L	L1	t max.	D min.	Ø d h6	Klemmhalter Typ toolholder type			
										K10F	CN45F	AL41F	P07C
R/L 005.0200-10	2.0	1.9	4.4	25	10	1.0	5.0	5.0	●	●	●		
R/L 005.0200-15	2.0	1.9	4.4	30	15	1.0	5.0	5.0	●	●	●		
R/L 005.0200-20	2.0	1.9	4.4	35	20	1.0	5.0	5.0	●	●	●	645... 650... ...5	
R/L 005.0200-25	2.0	1.9	4.4	40	25	1.0	5.0	5.0	●	●	●		
R/L 005.0200-30	2.0	1.9	4.4	45	30	1.0	5.0	5.0	●	●	●		

Weitere HM Sorten können Sie in der Sortenübersicht im Kapitel "Technische Hinweise" und der Preisliste finden.

Bestellbeispiel:
für rechte Ausführung und Sorte
R005.0200-10/AL41F

More carbide grades you can find in the grades summary in the chapter "technical instructions" and in the price list.

order-example:
righthand version and grade
R005.0200-10/AL41F

ULTRAMINI

Bohrungsbearbeitung
ab \varnothing 0.2 mm

grooving, boring and profiling
starting at \varnothing 0.2 mm

Typ 005M

Stechdrehen
mit Eckenradius

grooving
with corner radius

D min. 5.0 mm
Stechtiefe t max. 1.0 mm

D min. 5.0 mm
depth of groove t max. 1.0 mm

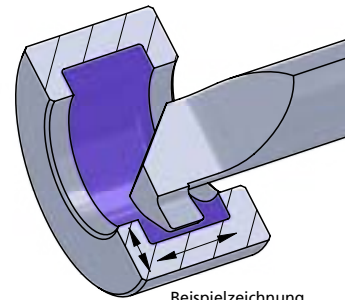
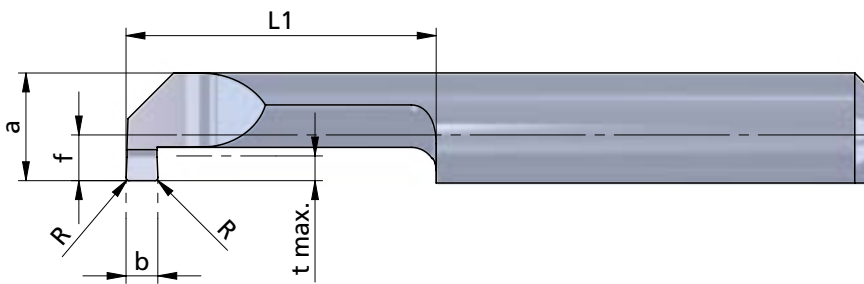
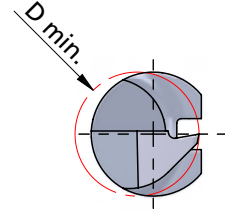
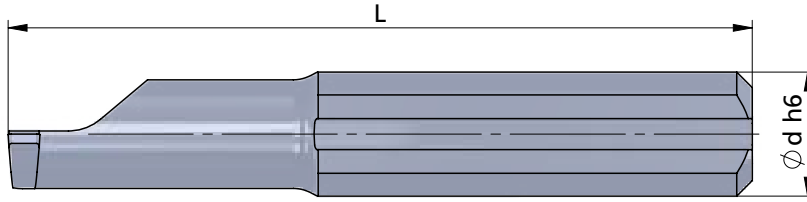

Beispielzeichnung
exemplary application

Rechts (R): wie gezeichnet
Links (L): spiegelbildlich

righthand (R): as shown
lefthand version (L): mirror image

Abmessungen in mm

dimensions in mm

Bestellnummer part number	b +0.05	b (inch)	R	f	a	L	L1	t max.	D min.	Ø d h6	Klemmhalter Typ toolholder type				
											K10F	CN45F	AL41F	P07C	
R/L 005M0100-10	1.0		0.1	1.9	4.4	25	10	1.0	5.0	5.0		●			
R/L 005M0100-15	1.0		0.1	1.9	4.4	30	15	1.0	5.0	5.0		●			
R/L 005M0100-20	1.0		0.1	1.9	4.4	35	20	1.0	5.0	5.0		●			
R/L 005M0100-25	1.0		0.1	1.9	4.4	40	25	1.0	5.0	5.0		●			
R/L 005M0100-30	1.0		0.1	1.9	4.4	45	30	1.0	5.0	5.0		●			
R/L 005M0150-10	1.5		0.1	1.9	4.4	25	10	1.0	5.0	5.0		●			
R/L 005M0150-15	1.5		0.1	1.9	4.4	30	15	1.0	5.0	5.0		●			
R/L 005M0150-20	1.5		0.1	1.9	4.4	35	20	1.0	5.0	5.0		●			
R/L 005M0150-25	1.5		0.1	1.9	4.4	40	25	1.0	5.0	5.0		●			
R/L 005M0150-30	1.5		0.1	1.9	4.4	45	30	1.0	5.0	5.0		●			
R/L 005M0157-20	1.57	0.062"	0.1	1.9	4.4	35	20	1.0	5.0	5.0		●			
↳ ...															

Weitere HM Sorten können Sie in der Sortenübersicht im Kapitel "Technische Hinweise" und der Preisliste finden.

More carbide grades you can find in the grades summary in the chapter "technical instructions" and in the price list.

ULTRAMINI

Bohrungsbearbeitung
ab $\varnothing 0.2$ mm

grooving, boring and profiling
starting at $\varnothing 0.2$ mm

Typ 005M

Stechdrehen
mit Eckenradius

grooving
with corner radius

D min. 5.0 mm
Stechtiefe t max. 1.0 mm

D min. 5.0 mm
depth of groove t max. 1.0 mm

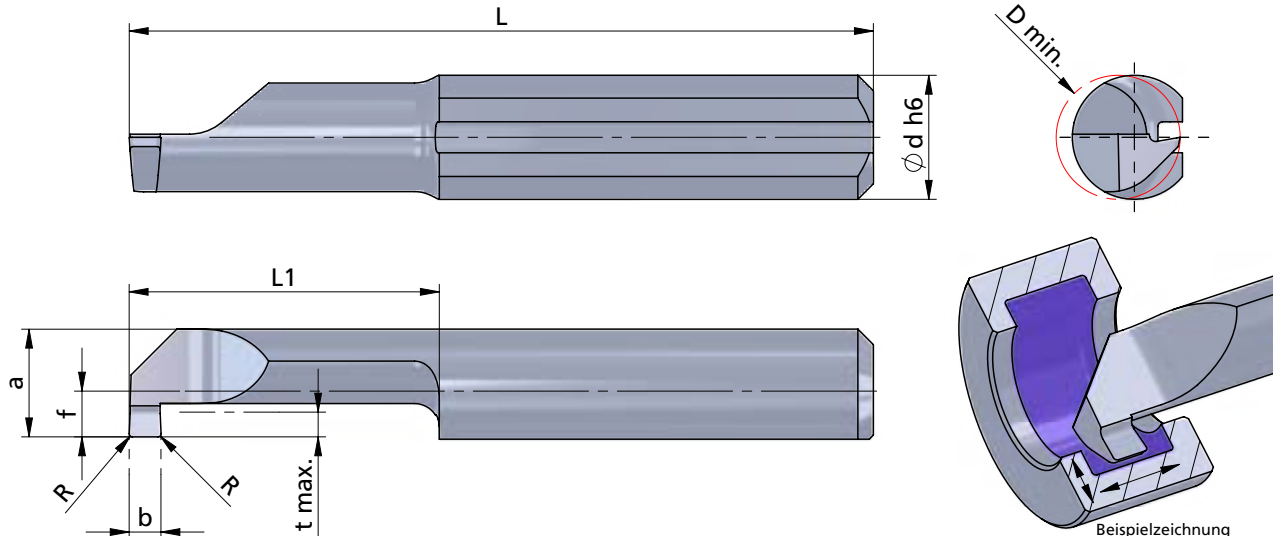

Rechts (R): wie gezeichnet
Links (L): spiegelbildlich

righthand (R): as shown
lefthand version (L): mirror image

Abmessungen in mm

dimensions in mm

Bestellnummer part number	b +0.05	b (inch)	R	f	a	L	L1	t max.	D min.	$\varnothing d h6$	Klemmhalter Typ toolholder type			
											K10F	CN45F	AL41F	P07C
R/L 005M0200-10	2.0	0.1	1.9	4.4	25	10	1.0	5.0	5.0	●				
R/L 005M0200-15	2.0	0.1	1.9	4.4	30	15	1.0	5.0	5.0	●				
R/L 005M0200-20	2.0	0.1	1.9	4.4	35	20	1.0	5.0	5.0	●				645... 650... ...5
R/L 005M0200-25	2.0	0.1	1.9	4.4	40	25	1.0	5.0	5.0	●				
R/L 005M0200-30	2.0	0.1	1.9	4.4	45	30	1.0	5.0	5.0	●				

Weitere HM Sorten können Sie in der Sortenübersicht im Kapitel "Technische Hinweise" und der Preisliste finden.

Bestellbeispiel:
für rechte Ausführung und Sorte
R005M0200-10/AL41F

More carbide grades you can find in the grades summary in the chapter "technical instructions" and in the price list.

order-example:
righthand version and grade
R005M0200-10/AL41F

ULTRAMINI

Bohrungsbearbeitung
ab $\varnothing 0.2$ mm

grooving, boring and profiling
starting at $\varnothing 0.2$ mm

Typ P05M

Stechdrehen
mit Eckenradius
und innerer Kühlmittelzufuhr

grooving
with corner radius
and through coolant

Performanceline

D min. 5.0 mm
Stechtiefe t max. 1.0 mm

D min. 5.0 mm
depth of groove t max. 1.0 mm

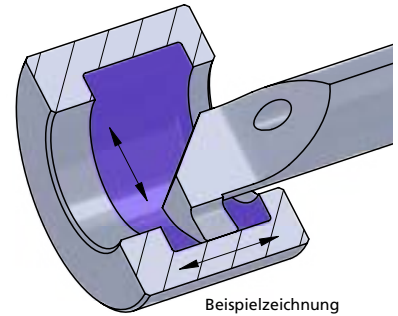
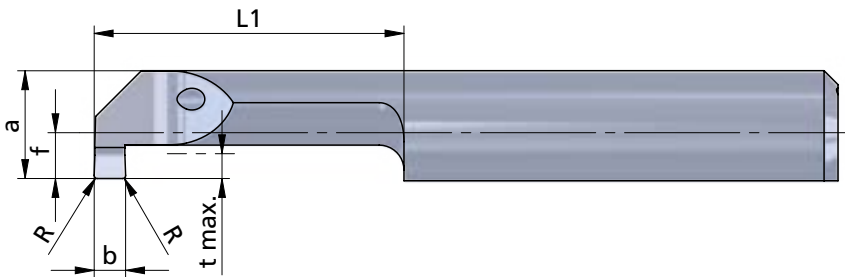
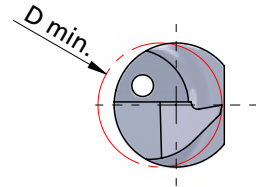
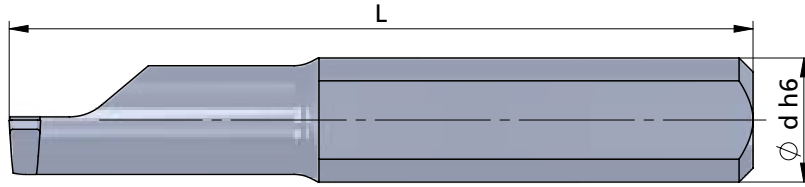

Beispielzeichnung
exemplary application

Rechts (R): wie gezeichnet
Links (L): spiegelbildlich

righthand (R): as shown
lefthand version (L): mirror image

Abmessungen in mm

dimensions in mm



Bestellnummer part number	b +0.05	b (inch)	R	f	a	L	L1	t max.	D min.	Ø d h6	K10F	P04C	AL41F	P07C	Klemmhalter Typ	toolholder type
	R/L P05M0100-10	1.0		0.1	1.9	4.4	25	10	1.0	5.0	5.0	●				645... 650... ...5
R/L P05M0100-15	1.0		0.1	1.9	4.4	30	15	1.0	5.0	5.0	●					
R/L P05M0100-20	1.0		0.1	1.9	4.4	35	20	1.0	5.0	5.0	●					
R/L P05M0100-25	1.0		0.1	1.9	4.4	40	25	1.0	5.0	5.0	●					
R/L P05M0100-30	1.0		0.1	1.9	4.4	45	30	1.0	5.0	5.0	●					
R/L P05M0150-10	1.5		0.1	1.9	4.4	25	10	1.0	5.0	5.0	●					
R/L P05M0150-15	1.5		0.1	1.9	4.4	30	15	1.0	5.0	5.0	●					
R/L P05M0150-20	1.5		0.1	1.9	4.4	35	20	1.0	5.0	5.0	●					
R/L P05M0150-25	1.5		0.1	1.9	4.4	40	25	1.0	5.0	5.0	●					
R/L P05M0150-30	1.5		0.1	1.9	4.4	45	30	1.0	5.0	5.0	●					
R/L P05M0157-20	1.57	0.062"	0.1	1.9	4.4	35	20	1.0	5.0	5.0	●					
↳ ...																

Weitere HM Sorten können Sie in der Sortenübersicht im Kapitel "Technische Hinweise" und der Preisliste finden.

More carbide grades you can find in the grades summary in the chapter "technical instructions" and in the price list.

ULTRAMINI

Bohrungsbearbeitung
ab \varnothing 0.2 mm

grooving, boring and profiling
starting at \varnothing 0.2 mm

Typ P05M

Stechdrehen
mit Eckenradius
und innerer Kühlmittelzufuhr

grooving
with corner radius
and through coolant

Performanceline

D min. 5.0 mm
Stechtiefe t max. 1.0 mm

D min. 5.0 mm
depth of groove t max. 1.0 mm

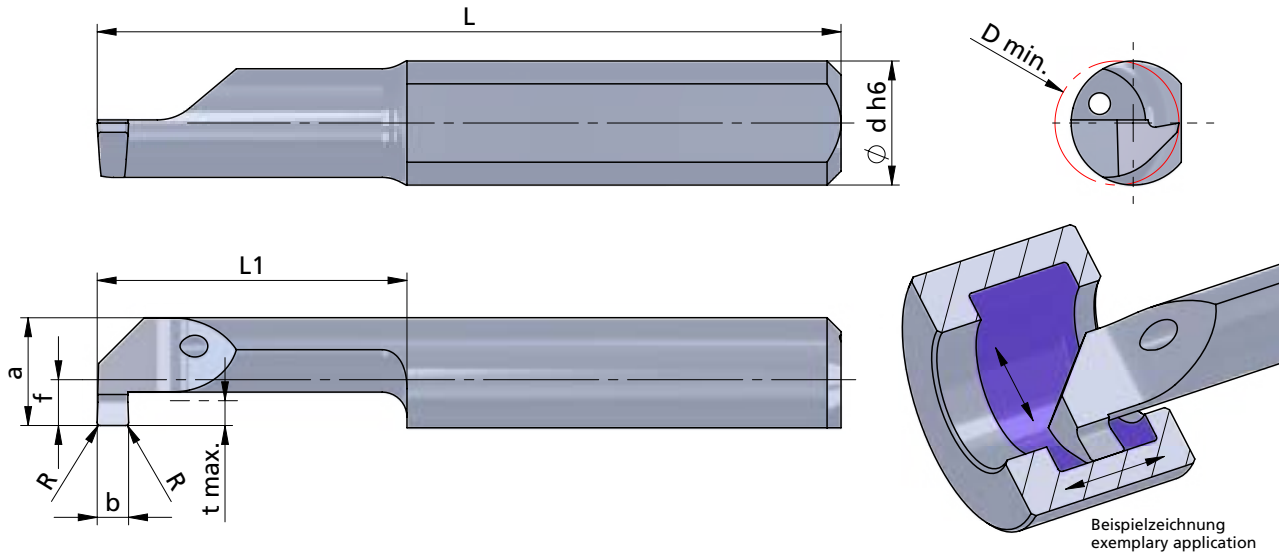

Rechts (R): wie gezeichnet
Links (L): spiegelbildlich

righthand (R): as shown
lefthand version (L): mirror image

Abmessungen in mm

dimensions in mm



Beispielzeichnung
exemplary application

Bestellnummer part number	b +0.05	b (inch)	R	f	a	L	L1	t max.	D min.	\varnothing d h6	Klemmhalter Typ toolholder type				
											K10F	P04C	AL41F	P07C	
⋮ ↴															
R/L P05M0200-10	2.0		0.1	1.9	4.4	25	10	1.0	5.0	5.0	●				
R/L P05M0200-15	2.0		0.1	1.9	4.4	30	15	1.0	5.0	5.0	●				
R/L P05M0200-20	2.0		0.1	1.9	4.4	35	20	1.0	5.0	5.0	●				645... 650... ...5
R/L P05M0200-25	2.0		0.1	1.9	4.4	40	25	1.0	5.0	5.0	●				
R/L P05M0200-30	2.0		0.1	1.9	4.4	45	30	1.0	5.0	5.0	●				

Weitere HM Sorten können Sie in der Sortenübersicht im Kapitel "Technische Hinweise" und der Preisliste finden.

Bestellbeispiel:
für rechte Ausführung und Sorte
RP05M0200-10/P04C

More carbide grades you can find in the grades summary in the chapter "technical instructions" and in the price list.

order-example:
righthand version and grade
RP05M0200-10/P04C

ULTRAMINI

Bohrungsbearbeitung
ab Ø 0.2 mm

grooving, boring and profiling
starting at Ø 0.2 mm

Typ 006

Stechdrehen

grooving

D min. 6.0 mm
Stechtiefe t max. 1.8 mm
Auskrägung (L1) bis 7x D

D min. 6.0 mm
depth of groove t max. 1.8 mm
overhang length (L1) up to 7x D

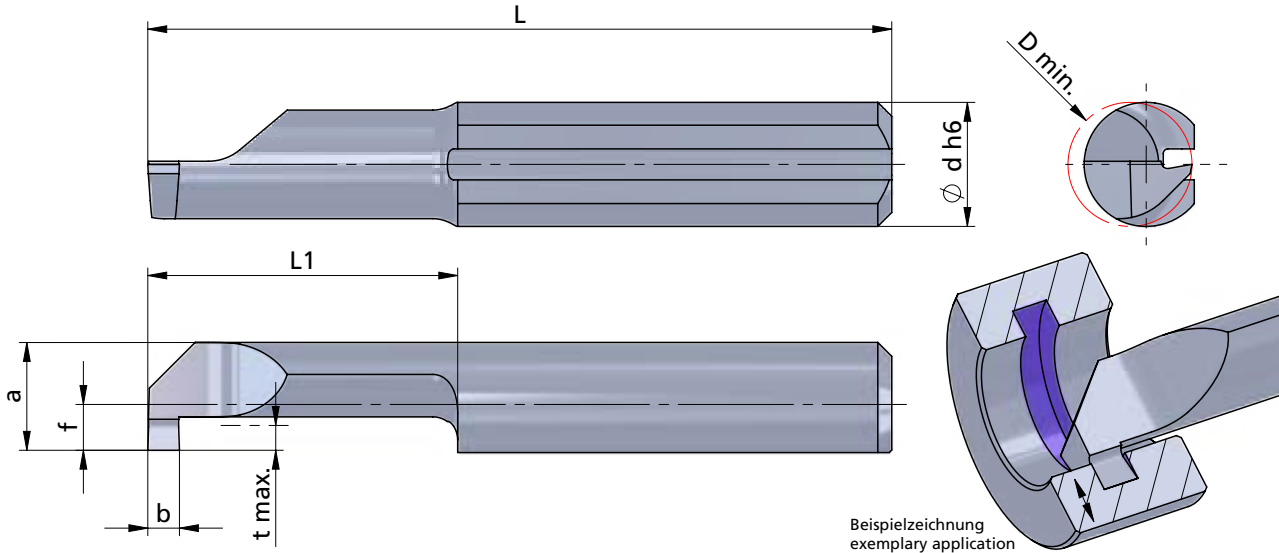

Beispielzeichnung
exemplary application

Rechts (R): wie gezeichnet
Links (L): spiegelbildlich

righthand (R): as shown
lefthand version (L): mirror image

Abmessungen in mm

dimensions in mm

Bestellnummer part number	b +0.05	f	a	L	L1	t max.	D min.	Ø d h6	K10F CN45F AL41F P07C	Klemmhalter Typ	toolholder type
R/L 006.0100-10	1.0	2.3	5.3	25	10	1.8	6.0	6.0	● ● ●	660... 676... ...6	
R/L 006.0100-15	1.0	2.3	5.3	30	15	1.8	6.0	6.0	● ● ●		
R/L 006.0100-22	1.0	2.3	5.3	37	22	1.8	6.0	6.0	● ● ●		
R/L 006.0100-25	1.0	2.3	5.3	40	25	1.8	6.0	6.0	● ● ●		
R/L 006.0100-30	1.0	2.3	5.3	45	30	1.8	6.0	6.0	● ● ●		
R/L 006.0100-35	1.0	2.3	5.3	50	35	1.8	6.0	6.0	● ● ●		
R/L 006.0100-42	1.0	2.3	5.3	57	42	1.8	6.0	6.0	● ●		
R/L 006.0150-10	1.5	2.3	5.3	25	10	1.8	6.0	6.0	● ● ●		
R/L 006.0150-15	1.5	2.3	5.3	30	15	1.8	6.0	6.0	● ● ●		
R/L 006.0150-22	1.5	2.3	5.3	37	22	1.8	6.0	6.0	● ● ●		
R/L 006.0150-25	1.5	2.3	5.3	40	25	1.8	6.0	6.0	● ● ●		
R/L 006.0150-30	1.5	2.3	5.3	45	30	1.8	6.0	6.0	● ● ●		
R/L 006.0150-35	1.5	2.3	5.3	50	35	1.8	6.0	6.0	● ● ●		
↳ ...											

Weitere HM Sorten können Sie in der Sortenübersicht im Kapitel "Technische Hinweise" und der Preisliste finden.

More carbide grades you can find in the grades summary in the chapter "technical instructions" and in the price list.

Bestellbeispiel:
für rechte Ausführung und Sorte
R006.0100-10/AL41F

order-example:
righthand version and grade
R006.0100-10/AL41F

ULTRAMINI

Bohrungsbearbeitung
ab \varnothing 0.2 mm

grooving, boring and profiling
starting at \varnothing 0.2 mm

Typ 006

Stechdrehen

grooving

D min. 6.0 mm
Stechtiefe t max. 1.8 mm
Auskragung (L1) bis 7x D

D min. 6.0 mm
depth of groove t max. 1.8 mm
overhang length (L1) up to 7x D

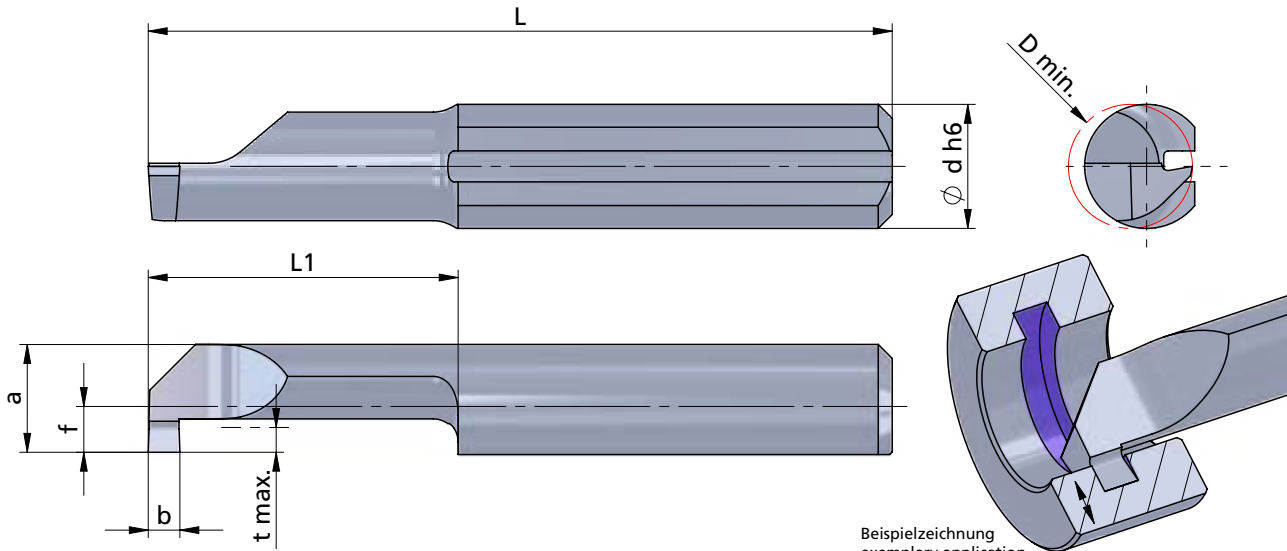

Rechts (R): wie gezeichnet
Links (L): spiegelbildlich

righthand (R): as shown
lefthand version (L): mirror image

Abmessungen in mm

dimensions in mm

Bestellnummer part number	b +0.05	f	a	L	L1	t max.	D min.	Ø d h6	Klemmhalter Typ toolholder type			
									K10F	CN45F	AL41F	P07C
R/L 006.0200-10	2.0	2.3	5.3	25	10	1.8	6.0	6.0	●	●	●	
R/L 006.0200-15	2.0	2.3	5.3	30	15	1.8	6.0	6.0	●	●	●	
R/L 006.0200-22	2.0	2.3	5.3	37	22	1.8	6.0	6.0	●	●	●	660... 676... ...6
R/L 006.0200-25	2.0	2.3	5.3	40	25	1.8	6.0	6.0	●	●	●	
R/L 006.0200-30	2.0	2.3	5.3	45	30	1.8	6.0	6.0	●	●	●	

Weitere HM Sorten können Sie in der Sortenübersicht im Kapitel "Technische Hinweise" und der Preisliste finden.

Bestellbeispiel:
für rechte Ausführung und Sorte
R006.0200-10/AL41F

More carbide grades you can find in the grades summary in the chapter "technical instructions" and in the price list.

order-example:
righthand version and grade
R006.0200-10/AL41F

ULTRAMINI

Bohrungsbearbeitung
ab $\varnothing 0.2$ mm

grooving, boring and profiling
starting at $\varnothing 0.2$ mm

Typ 006M

Stechdrehen
mit Eckenradius

grooving
with corner radius

D min. 6.0 mm
Stechtiefe t max. 1.8 mm

D min. 6.0 mm
depth of groove t max. 1.8 mm

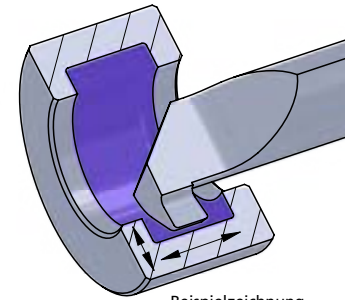
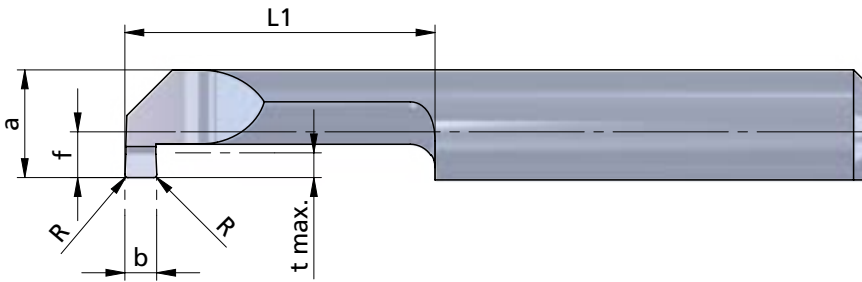
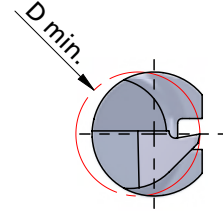
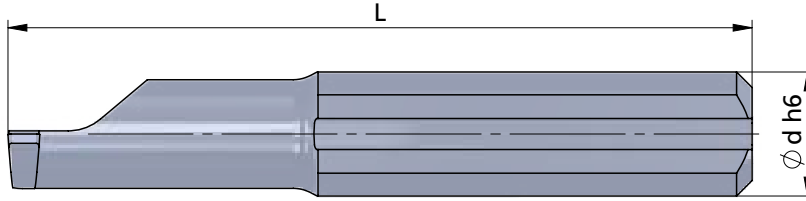
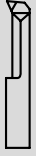

Beispielzeichnung
exemplary application

Rechts (R): wie gezeichnet
Links (L): spiegelbildlich

righthand (R): as shown
lefthand version (L): mirror image

Abmessungen in mm

dimensions in mm

Bestellnummer part number	b +0.05	b (inch)	R	f	a	L	L1	t max.	D min.	Ø d h6	Klemmhalter Typ				Klemmhalter Typ toolholder type
											K10F	CN45F	AL41F	PD2F	
R/L 006M0079-15	0.79	0.031"	0.1	2.3	5.3	30	15	1.8	6.0	6.0		●			660 ... 6766
R/L 006M0100-10	1.0		0.1	2.3	5.3	25	10	1.8	6.0	6.0		●	●		
R/L 006M0100-15	1.0		0.1	2.3	5.3	30	15	1.8	6.0	6.0		●			
R/L 006M0100-22	1.0		0.1	2.3	5.3	37	22	1.8	6.0	6.0		●			
R/L 006M0100-25	1.0		0.1	2.3	5.3	40	25	1.8	6.0	6.0		●			
R/L 006M0100-30	1.0		0.1	2.3	5.3	45	30	1.8	6.0	6.0		●			
R/L 006M0117-15	1.17	0.046"	0.1	2.3	5.3	30	15	1.8	6.0	6.0		●			
R/L 006M0150-10	1.5		0.1	2.3	5.3	25	10	1.8	6.0	6.0		●			
R/L 006M0150-15	1.5		0.1	2.3	5.3	30	15	1.8	6.0	6.0		●			
R/L 006M0150-22	1.5		0.1	2.3	5.3	37	22	1.8	6.0	6.0		●			
R/L 006M0150-25	1.5		0.1	2.3	5.3	40	25	1.8	6.0	6.0		●			
R/L 006M0150-30	1.5		0.1	2.3	5.3	45	30	1.8	6.0	6.0		●			
↳ ...															

Weitere HM Sorten können Sie in der Sortenübersicht im Kapitel "Technische Hinweise" und der Preisliste finden.

More carbide grades you can find in the grades summary in the chapter "technical instructions" and in the price list.

Bestellbeispiel:
für rechte Ausführung und Sorte
R006M0100-10/AL41F

order-example:
righthand version and grade
R006M0100-10/AL41F

ULTRAMINI

Bohrungsbearbeitung
ab \varnothing 0.2 mm

grooving, boring and profiling
starting at \varnothing 0.2 mm

Typ 006M

Stechdrehen
mit Eckenradius

grooving
with corner radius

D min. 6.0 mm
Stechtiefe t max. 1.8 mm

D min. 6.0 mm
depth of groove t max. 1.8 mm

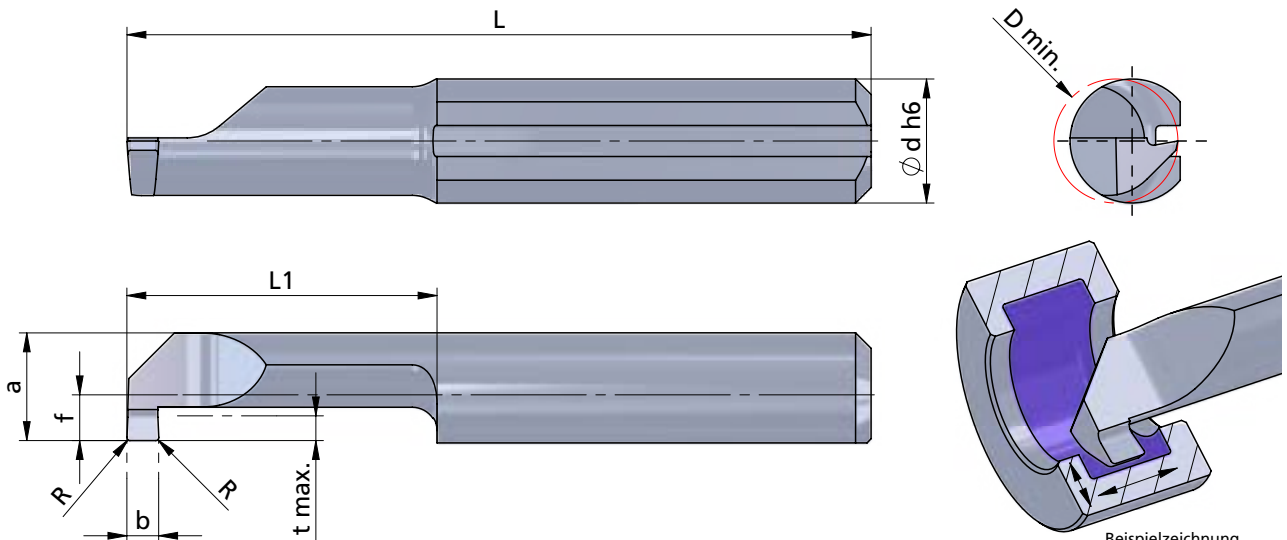

Rechts (R): wie gezeichnet
Links (L): spiegelbildlich

righthand (R): as shown
lefthand version (L): mirror image

Abmessungen in mm

dimensions in mm

Bestellnummer part number	b +0.05	b (inch)	R	f	a	L	L1	t max.	D min.	Ø d h6	Klemmhalter Typ				Klemmhalter Typ toolholder type
											K10F	CN45F	AL41F	PD2F	
⋮ ↴															
R/L 006M0198-15	1.98	0.078"	0.1	2.3	5.3	30	15	1.8	6.0	6.0		●			
R/L 006M0200-10	2.0		0.1	2.3	5.3	25	10	1.8	6.0	6.0		●			
R/L 006M0200-15	2.0		0.1	2.3	5.3	30	15	1.8	6.0	6.0		●			
R/L 006M0200-22	2.0		0.1	2.3	5.3	37	22	1.8	6.0	6.0		●			660... 676... ...6
R/L 006M0200-25	2.0		0.1	2.3	5.3	40	25	1.8	6.0	6.0		●			
R/L 006M0200-30	2.0		0.1	2.3	5.3	45	30	1.8	6.0	6.0		●			

Weitere HM Sorten können Sie in der Sortenübersicht im Kapitel "Technische Hinweise" und der Preisliste finden.

Bestellbeispiel:
für rechte Ausführung und Sorte
R006M0198-15/AL41F

More carbide grades you can find in the grades summary in the chapter "technical instructions" and in the price list.

order-example:
righthand version and grade
R006M0198-15/AL41F

ULTRAMINI

Bohrungsbearbeitung
ab \varnothing 0.2 mm

grooving, boring and profiling
starting at \varnothing 0.2 mm

Typ P06M

Stechdrehen
mit Eckenradius
und innerer Kühlmittelzufuhr

grooving
with corner radius
and through coolant

Performanceline

D min. 6.0 mm
Stechtiefe t max. 1.8 mm

D min. 6.0 mm
depth of groove t max. 1.8 mm

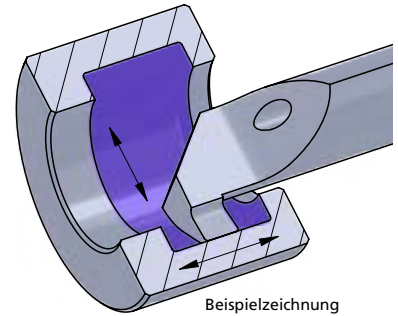
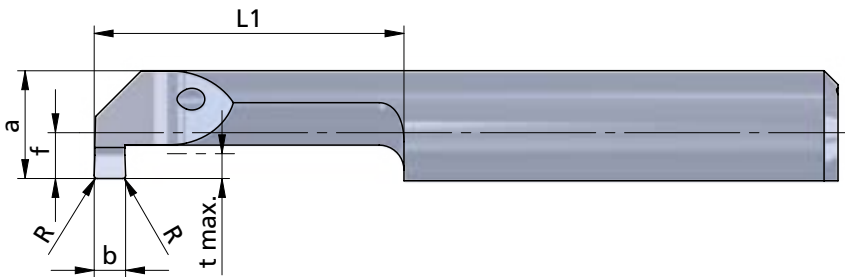
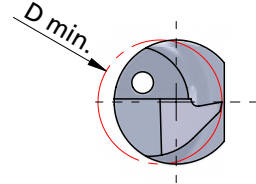
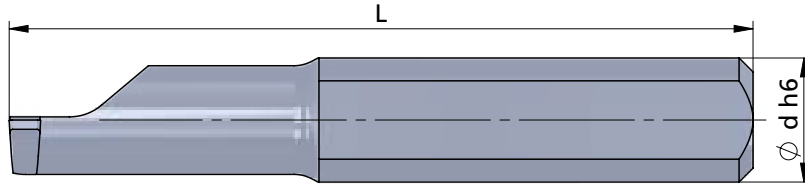
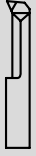

Beispielzeichnung
exemplary application

Rechts (R): wie gezeichnet
Links (L): spiegelbildlich

righthand (R): as shown
lefthand version (L): mirror image

Abmessungen in mm

dimensions in mm



Bestellnummer part number	b +0.05	b (inch)	R	f	a	L	L1	t max.	D min.	\varnothing d h6	Klemmhalter Typ toolholder type					
											K10F	P04C	AL41F	PD2F		
R/L P06M0079-15	0.79	0.031"	0.1	2.3	5.3	30	15	1.8	6.0	6.0	●	●	●	●	660 ... 6766	
R/L P06M0100-10	1.0		0.1	2.3	5.3	25	10	1.8	6.0	6.0	●	●	●	●		
R/L P06M0100-15	1.0		0.1	2.3	5.3	30	15	1.8	6.0	6.0	●	●	●	●		
R/L P06M0100-22	1.0		0.1	2.3	5.3	37	22	1.8	6.0	6.0	●	●	●	●		
R/L P06M0100-25	1.0		0.1	2.3	5.3	40	25	1.8	6.0	6.0	●	●	●	●		
R/L P06M0100-30	1.0		0.1	2.3	5.3	45	30	1.8	6.0	6.0	●	●	●	●		
R/L P06M0117-15	1.17	0.046"	0.1	2.3	5.3	30	15	1.8	6.0	6.0	●	●	●	●		
R/L P06M0150-10	1.5		0.1	2.3	5.3	25	10	1.8	6.0	6.0	●	●	●	●		
R/L P06M0150-15	1.5		0.1	2.3	5.3	30	15	1.8	6.0	6.0	●	●	●	●		
R/L P06M0150-22	1.5		0.1	2.3	5.3	37	22	1.8	6.0	6.0	●	●	●	●		
R/L P06M0150-25	1.5		0.1	2.3	5.3	40	25	1.8	6.0	6.0	●	●	●	●		
R/L P06M0150-30	1.5		0.1	2.3	5.3	45	30	1.8	6.0	6.0	●	●	●	●		
↳ ...																

Weitere HM Sorten können Sie in der Sortenübersicht im Kapitel "Technische Hinweise" und der Preisliste finden.

More carbide grades you can find in the grades summary in the chapter "technical instructions" and in the price list.

Bestellbeispiel:
für rechte Ausführung und Sorte
RP06M0079-15/P04C

order-example:
righthand version and grade
RP06M0079-15/P04C

ULTRAMINI

Bohrungsbearbeitung
ab \varnothing 0.2 mm

grooving, boring and profiling
starting at \varnothing 0.2 mm

Typ P06M

Stechdrehen
mit Eckenradius
und innerer Kühlmittelzufuhr

grooving
with corner radius
and through coolant

Performanceline

D min. 6.0 mm
Stechtiefe t max. 1.8 mm

D min. 6.0 mm
depth of groove t max. 1.8 mm

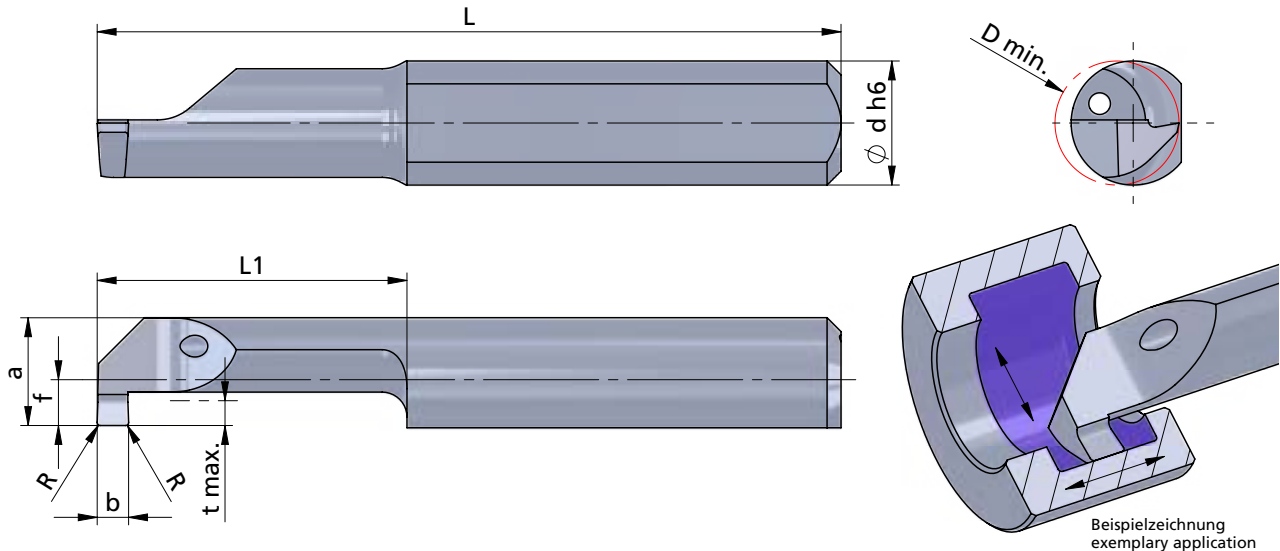

Rechts (R): wie gezeichnet
Links (L): spiegelbildlich

righthand (R): as shown
lefthand version (L): mirror image

Abmessungen in mm

dimensions in mm



Bestellnummer part number	b +0.05	b (inch)	R	f	a	L	L1	t max.	D min.	Ø d h6	Material				Klemmhalter Typ toolholder type
											K10F	P04C	AL41F	PD2F	
⋮ ↴															
R/L P06M0198-15	1.98	0.078"	0.1	2.3	5.3	30	15	1.8	6.0	6.0	●	●	●	●	660... 676... ...:6
R/L P06M0200-10	2.0		0.1	2.3	5.3	25	10	1.8	6.0	6.0	●	●	●	●	
R/L P06M0200-15	2.0		0.1	2.3	5.3	30	15	1.8	6.0	6.0	●	●	●	●	
R/L P06M0200-22	2.0		0.1	2.3	5.3	37	22	1.8	6.0	6.0	●	●	●	●	
R/L P06M0200-25	2.0		0.1	2.3	5.3	40	25	1.8	6.0	6.0	●	●	●	●	
R/L P06M0200-30	2.0		0.1	2.3	5.3	45	30	1.8	6.0	6.0	●	●	●	●	

Weitere HM Sorten können Sie in der Sortenübersicht im Kapitel "Technische Hinweise" und der Preisliste finden.

Bestellbeispiel:
für rechte Ausführung und Sorte
RP06M0198-15/P04C

More carbide grades you can find in the grades summary in the chapter "technical instructions" and in the price list.

order-example:
righthand version and grade
RP06M0198-15/P04C

ULTRAMINI

Bohrungsbearbeitung
ab \varnothing 0.2 mm

grooving, boring and profiling
starting at \varnothing 0.2 mm

Typ 007

Stechdrehen

grooving

D min. 6.8 mm
Stechtiefe t max. 2.5 mm
Auskragung (L1) bis 7x D

D min. 6.8 mm
depth of groove t max. 2.5 mm
overhang length (L1) up to 7x D

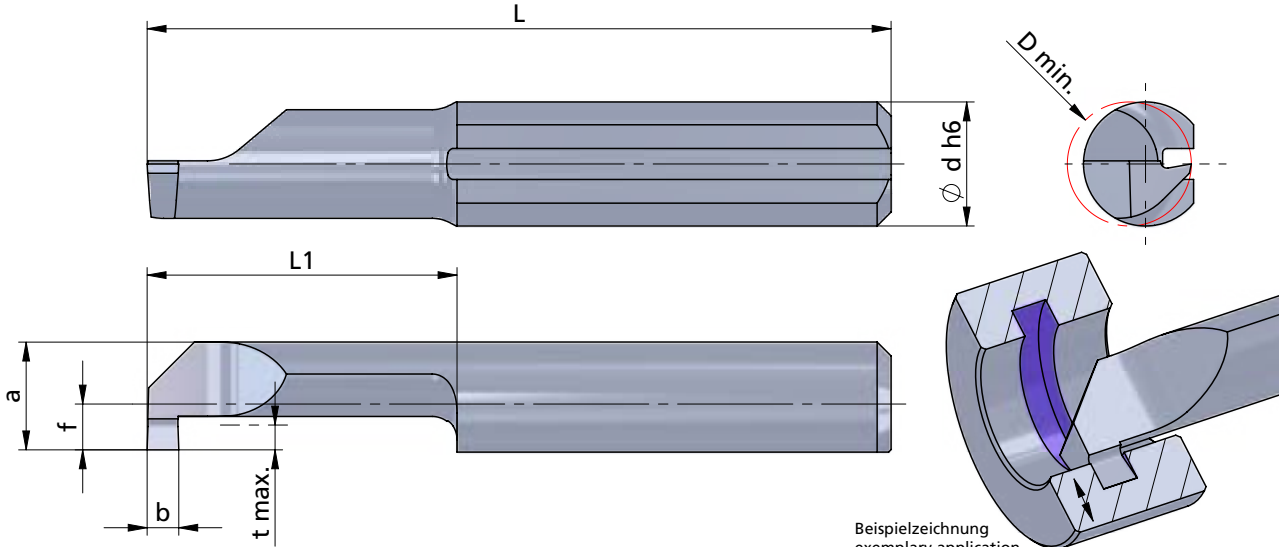

Beispielzeichnung
exemplary application

Rechts (R): wie gezeichnet
Links (L): spiegelbildlich

righthand (R): as shown
lefthand version (L): mirror image

Abmessungen in mm

dimensions in mm

Bestellnummer part number	b +0.05	b (inch)	f	a	L	L1	t max.	D min.	Ø d h6	Klemmhalter Typ				Klemmhalter Typ toolholder type
										K10F	CN45F	AL41F	PD2F	
R/L 007.0079-10	0.79	0.031"	2.8	6.3	25	10	2.5	6.8	7.0	●		●		670... 676... 687... ...7
R/L 007.0079-25	0.79	0.031"	2.8	6.3	40	25	2.5	6.8	7.0	●		●		
R/L 007.0100-10	1.0		2.8	6.3	25	10	2.5	6.8	7.0	●	●	●		
R/L 007.0100-15	1.0		2.8	6.3	30	15	2.5	6.8	7.0	●	●	●		
R/L 007.0100-22	1.0		2.8	6.3	37	22	2.5	6.8	7.0	●	●	●		
R/L 007.0100-25	1.0		2.8	6.3	40	25	2.5	6.8	7.0	●	●	●		
R/L 007.0100-30	1.0		2.8	6.3	45	30	2.5	6.8	7.0	●	●	●		
R/L 007.0100-35	1.0		2.8	6.3	50	35	2.5	7.0	7.0		●	●		
R/L 007.0100-40	1.0		2.8	6.3	55	40	2.5	7.0	7.0		●	●		
R/L 007.0100-45	1.0		2.8	6.3	60	45	2.5	7.0	7.0		●	●		
R/L 007.0100-50	1.0		2.8	6.3	65	50	2.5	7.0	7.0		●	●		
↳ ...														

Weitere HM Sorten können Sie in der Sortenübersicht im Kapitel "Technische Hinweise" und der Preisliste finden.

More carbide grades you can find in the grades summary in the chapter "technical instructions" and in the price list.

Bestellbeispiel:
für rechte Ausführung und Sorte
R007.0100-10/AL41F

order-example:
righthand version and grade
R007.0100-10/AL41F

ULTRAMINI

Bohrungsbearbeitung
ab \varnothing 0.2 mm

grooving, boring and profiling
starting at \varnothing 0.2 mm

Typ 007

Stechdrehen

grooving

D min. 6.8 mm
Stechtiefe t max. 2.5 mm
Auskragung (L1) bis 7x D

D min. 6.8 mm
depth of groove t max. 2.5 mm
overhang length (L1) up to 7x D

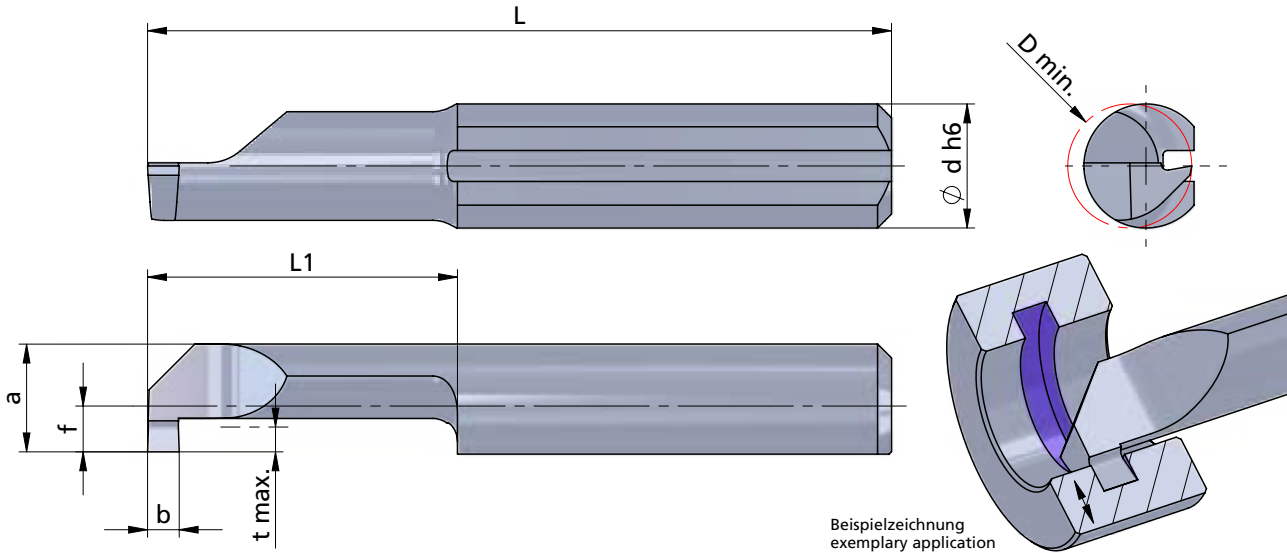

Rechts (R): wie gezeichnet
Links (L): spiegelbildlich

righthand (R): as shown
lefthand version (L): mirror image

Abmessungen in mm

dimensions in mm

Bestellnummer part number	b +0.05	b (inch)	f	a	L	L1	t max.	D min.	Ø d h6	Klemmhalter Typ toolholder type				
										K10F	CN45F	AL41F	PD2F	
⋮ ↘														
R/L 007.0150-10	1.5		2.8	6.3	25	10	2.5	6.8	7.0	●	●	●		670... 676... 687... ...7
R/L 007.0150-15	1.5		2.8	6.3	30	15	2.5	6.8	7.0	●	●	●		
R/L 007.0150-22	1.5		2.8	6.3	37	22	2.5	6.8	7.0	●	●	●		
R/L 007.0150-25	1.5		2.8	6.3	40	25	2.5	6.8	7.0	●	●	●		
R/L 007.0150-30	1.5		2.8	6.3	45	30	2.5	6.8	7.0	●	●	●		
R/L 007.0150-35	1.5		2.8	6.3	50	35	2.5	7.0	7.0		●	●		
R/L 007.0150-40	1.5		2.8	6.3	55	40	2.5	7.0	7.0		●	●	●	
R/L 007.0200-10	2.0		2.8	6.3	25	10	2.5	6.8	7.0	●	●	●		
R/L 007.0200-15	2.0		2.8	6.3	30	15	2.5	6.8	7.0	●	●	●		
R/L 007.0200-22	2.0		2.8	6.3	37	22	2.5	6.8	7.0	●	●	●		
R/L 007.0200-25	2.0		2.8	6.3	40	25	2.5	6.8	7.0	●	●	●		
R/L 007.0200-30	2.0		2.8	6.3	45	30	2.5	6.8	7.0	●	●	●	●	
R/L 007.0200-35	2.0		2.8	6.3	50	35	2.5	7.0	7.0	●	●	●		

Weitere HM Sorten können Sie in der Sortenübersicht im Kapitel "Technische Hinweise" und der Preisliste finden.

More carbide grades you can find in the grades summary in the chapter "technical instructions" and in the price list.

Bestellbeispiel:
für rechte Ausführung und Sorte
R007.0150-10/AL41F

order-example:
righthand version and grade
R007.0150-10/AL41F

ULTRAMINI

Bohrungsbearbeitung
ab \varnothing 0.2 mm

grooving, boring and profiling
starting at \varnothing 0.2 mm

Typ 007M

Stechdrehen
mit Eckenradius

grooving
with corner radius

D min. 6.8 mm
Stechtiefe t max. 2.5 mm

D min. 6.8 mm
depth of groove t max. 2.5 mm

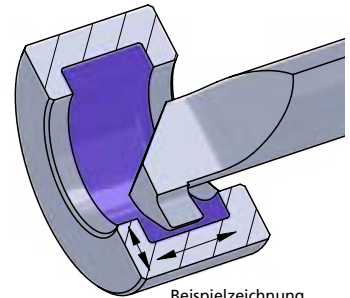
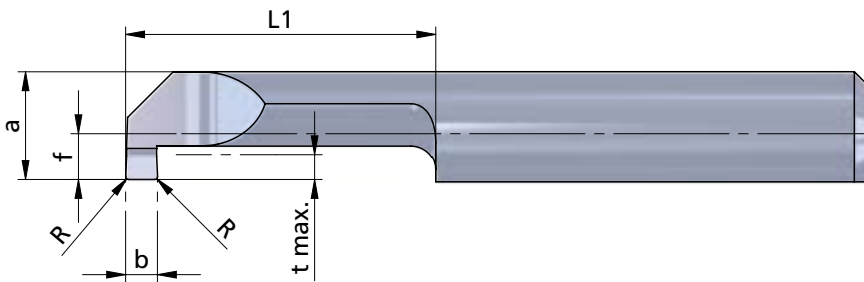
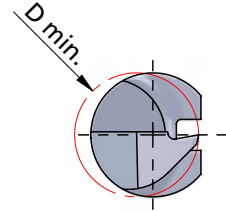
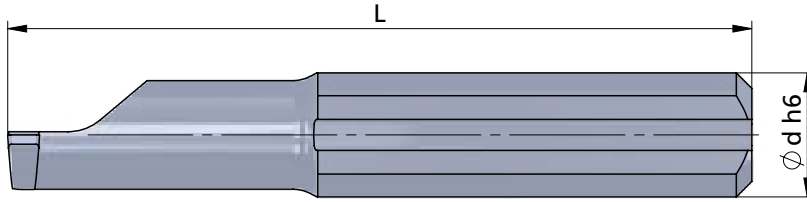

Beispielzeichnung
exemplary application

Rechts (R): wie gezeichnet
Links (L): spiegelbildlich

righthand (R): as shown
lefthand version (L): mirror image

Abmessungen in mm

dimensions in mm

Bestellnummer part number	b		R	f	a	L	L1	t max.	D min.	Ø d h6	Klemmhalter Typ toolholder type				
	b +0.05	b (inch)									K10F	CN45F	AL41F	P07C	
R/L 007M0100-10	1.0		0.1	2.8	6.3	25	10	2.5	6.8	7.0		●			
R/L 007M0100-15	1.0		0.1	2.8	6.3	30	15	2.5	6.8	7.0		●			
R/L 007M0100-22	1.0		0.1	2.8	6.3	37	22	2.5	6.8	7.0		●			
R/L 007M0100-25	1.0		0.1	2.8	6.3	40	25	2.5	6.8	7.0		●			
R/L 007M0100-30	1.0		0.1	2.8	6.3	45	30	2.5	6.8	7.0		●			
R/L 007M0117-10	1.17	0.046"	0.1	2.8	6.3	25	10	2.5	6.8	7.0		●			
R/L 007M0117-22	1.17	0.046"	0.1	2.8	6.3	37	22	2.5	6.8	7.0		●			
R/L 007M0150-10	1.5		0.1	2.8	6.3	25	10	2.5	6.8	7.0		●			
R/L 007M0150-15	1.5		0.1	2.8	6.3	30	15	2.5	6.8	7.0		●			
R/L 007M0150-22	1.5		0.1	2.8	6.3	37	22	2.5	6.8	7.0		●			
R/L 007M0150-25	1.5		0.1	2.8	6.3	40	25	2.5	6.8	7.0		●			
R/L 007M0150-30	1.5		0.1	2.8	6.3	45	30	2.5	6.8	7.0		●			
R/L 007M0157-10	1.57	0.062"	0.1	2.8	6.3	25	10	2.5	6.8	7.0		●			
R/L 007M0157-25	1.57	0.062"	0.1	2.8	6.3	40	25	2.5	6.8	7.0		●			
↳ ...															

670...
676...
687...
...7

Weitere HM Sorten können Sie in der Sortenübersicht im Kapitel "Technische Hinweise" und der Preisliste finden.

More carbide grades you can find in the grades summary in the chapter "technical instructions" and in the price list.

Bestellbeispiel:
für rechte Ausführung und Sorte
R007M0100-10/AL41F

order-example:
righthand version and grade
R007M0100-10/AL41F

ULTRAMINI

Bohrungsbearbeitung
ab \varnothing 0.2 mm

grooving, boring and profiling
starting at \varnothing 0.2 mm

Typ 007M

Stechdrehen
mit Eckenradius

grooving
with corner radius

D min. 6.8 mm
Stechtiefe t max. 2.5 mm

D min. 6.8 mm
depth of groove t max. 2.5 mm

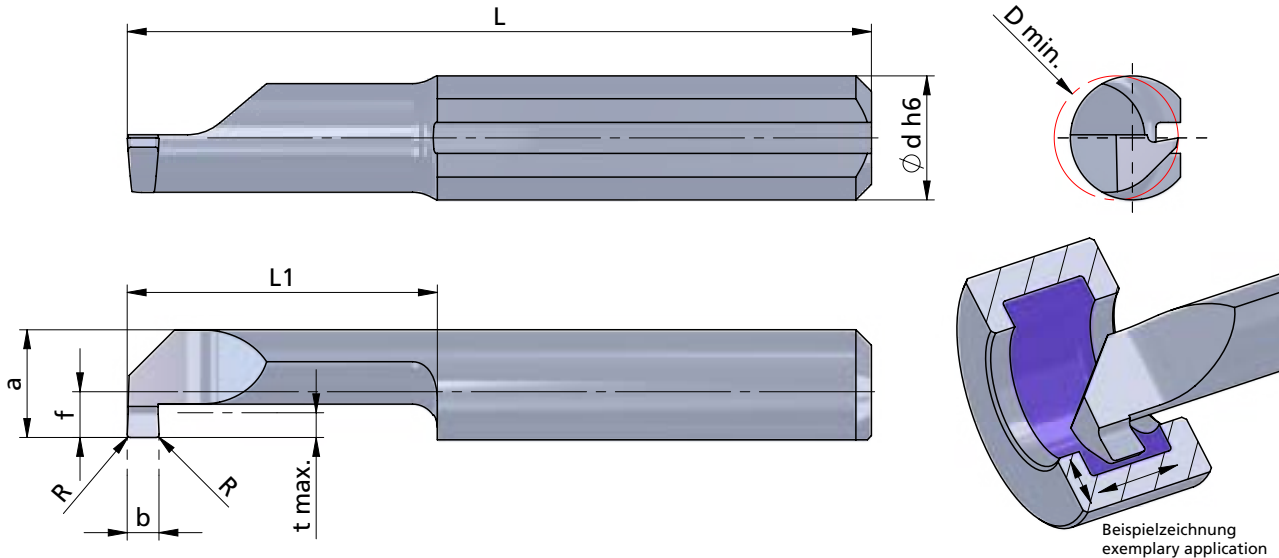

Rechts (R): wie gezeichnet
Links (L): spiegelbildlich

righthand (R): as shown
lefthand version (L): mirror image

Abmessungen in mm

dimensions in mm

Bestellnummer part number	b +0.05	b (inch)	R	f	a	L	L1	t max.	D min.	Ø d h6	Klemmhalter Typ toolholder type				
											K10F	CN45F	AL41F	P07C	
⋮ ↙															
R/L 007M0198-22	1.98	0.078"	0.1	2.8	6.3	37	22	2.5	6.8	7.0		●			
R/L 007M0200-10	2.0		0.1	2.8	6.3	25	10	2.5	6.8	7.0		●			
R/L 007M0200-15	2.0		0.1	2.8	6.3	30	15	2.5	6.8	7.0		●			
R/L 007M0200-22	2.0		0.1	2.8	6.3	37	22	2.5	6.8	7.0		●			670... 676... 687... ...7
R/L 007M0200-25	2.0		0.1	2.8	6.3	40	25	2.5	6.8	7.0		●			
R/L 007M0200-30	2.0		0.1	2.8	6.3	45	30	2.5	6.8	7.0		●			

Weitere HM Sorten können Sie in der Sortenübersicht im Kapitel "Technische Hinweise" und der Preisliste finden.

Bestellbeispiel:
für rechte Ausführung und Sorte
R007M0200-10/AL41F

More carbide grades you can find in the grades summary in the chapter "technical instructions" and in the price list.

order-example:
righthand version and grade
R007M0200-10/AL41F

ULTRAMINI

Bohrungsbearbeitung
ab \varnothing 0.2 mm

grooving, boring and profiling
starting at \varnothing 0.2 mm

Typ P07M

Stechdrehen
mit Eckenradius
und innerer Kühlmittelzufuhr

grooving
with corner radius
and through coolant

Performanceline

D min. 6.8 mm
Stechtiefe t max. 2.5 mm

D min. 6.8 mm
depth of groove t max. 2.5 mm

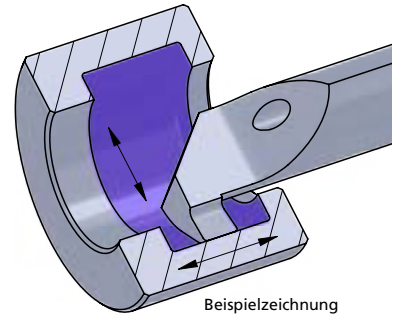
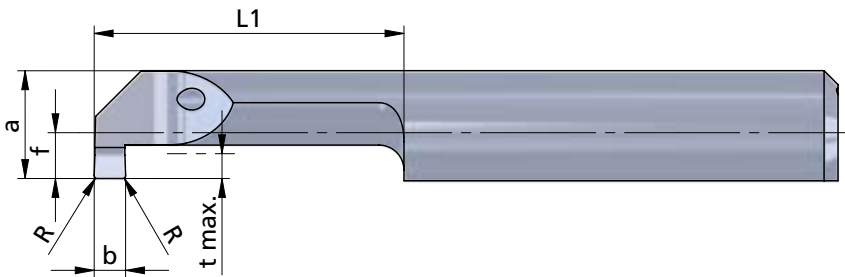
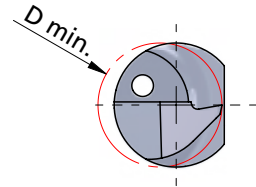
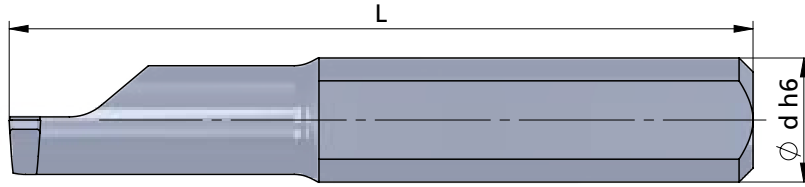

Beispielzeichnung
exemplary application

Rechts (R): wie gezeichnet
Links (L): spiegelbildlich

righthand (R): as shown
lefthand version (L): mirror image

Abmessungen in mm

dimensions in mm



Bestellnummer part number	b		R	f	a	L	L1	t max.	D min.	Ø d h6	Klemmhalter Typ toolholder type				
	b +0.05	b (inch)									K10F	P04C	AL41F	P07C	
R/L P07M0100-10	1.0		0.1	2.8	6.3	25	10	2.5	6.8	7.0	●				
R/L P07M0100-15	1.0		0.1	2.8	6.3	30	15	2.5	6.8	7.0	●				
R/L P07M0100-22	1.0		0.1	2.8	6.3	37	22	2.5	6.8	7.0	●				
R/L P07M0100-25	1.0		0.1	2.8	6.3	40	25	2.5	6.8	7.0	●				
R/L P07M0100-30	1.0		0.1	2.8	6.3	45	30	2.5	6.8	7.0	●				
R/L 007M0117-10	1.17	0.046"	0.1	2.8	6.3	25	10	2.5	6.8	7.0	●				
R/L P07M0117-22	1.17	0.046"	0.1	2.8	6.3	37	22	2.5	6.8	7.0	●				
R/L P07M0150-10	1.5		0.1	2.8	6.3	25	10	2.5	6.8	7.0	●				670 ...
R/L P07M0150-15	1.5		0.1	2.8	6.3	30	15	2.5	6.8	7.0	●				676 ...
R/L P07M0150-22	1.5		0.1	2.8	6.3	37	22	2.5	6.8	7.0	●				687 ...
R/L P07M0150-25	1.5		0.1	2.8	6.3	40	25	2.5	6.8	7.0	●				...7
R/L P07M0150-30	1.5		0.1	2.8	6.3	45	30	2.5	6.8	7.0	●				
R/L P07M0157-10	1.57	0.062"	0.1	2.8	6.3	25	10	2.5	6.8	7.0	●				
R/L P07M0157-25	1.57	0.062"	0.1	2.8	6.3	40	25	2.5	6.8	7.0	●				
↳ ...															

Weitere HM Sorten können Sie in der Sortenübersicht im Kapitel "Technische Hinweise" und der Preisliste finden.

More carbide grades you can find in the grades summary in the chapter "technical instructions" and in the price list.

Bestellbeispiel:
für rechte Ausführung und Sorte
RP07M0100-10/P04C

order-example:
righthand version and grade
RP07M0100-10/P04C

ULTRAMINI

Bohrungsbearbeitung
ab \varnothing 0.2 mm

grooving, boring and profiling
starting at \varnothing 0.2 mm

Typ P07M

Stechdrehen
mit Eckenradius
und innerer Kühlmittelzufuhr

grooving
with corner radius
and through coolant

Performanceline

D min. 6.8 mm
Stechtiefe t max. 2.5 mm

D min. 6.8 mm
depth of groove t max. 2.5 mm

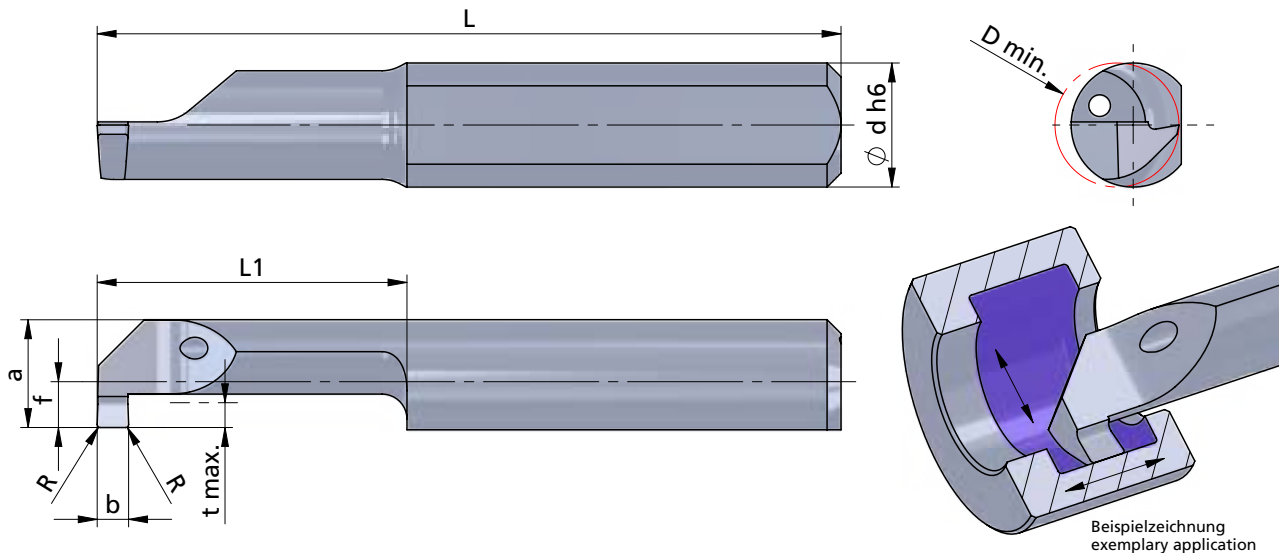

Rechts (R): wie gezeichnet
Links (L): spiegelbildlich

righthand (R): as shown
lefthand version (L): mirror image

Abmessungen in mm

dimensions in mm



Bestellnummer part number	b +0.05	b (inch)	R	f	a	L	L1	t max.	D min.	Ø d h6	Material				Klemmhalter Typ toolholder type
											K10F	P04C	AL41F	P07C	
⋮ ↙															
R/L P07M0198-22	1.98	0.078"	0.1	2.8	6.3	37	22	2.5	6.8	7.0	●				
R/L P07M0200-10	2.0		0.1	2.8	6.3	25	10	2.5	6.8	7.0	●				
R/L P07M0200-15	2.0		0.1	2.8	6.3	30	15	2.5	6.8	7.0	●				
R/L P07M0200-22	2.0		0.1	2.8	6.3	37	22	2.5	6.8	7.0	●				670... 676... 687... ...7
R/L P07M0200-25	2.0		0.1	2.8	6.3	40	25	2.5	6.8	7.0	●				
R/L P07M0200-30	2.0		0.1	2.8	6.3	45	30	2.5	6.8	7.0	●				

Weitere HM Sorten können Sie in der Sortenübersicht im Kapitel "Technische Hinweise" und der Preisliste finden.

Bestellbeispiel:
für rechte Ausführung und Sorte
RP07M0198-22/P04C

More carbide grades you can find in the grades summary in the chapter "technical instructions" and in the price list.

order-example:
righthand version and grade
RP07M0198-22/P04C

ULTRAMINI

Bohrungsbearbeitung
ab \varnothing 0.2 mm

grooving, boring and profiling
starting at \varnothing 0.2 mm

Typ 008M

Stechdrehen
mit Eckenradius

grooving
with corner radius

D min. 7.8 mm
Stechtiefe t max. 3.0 mm

D min. 7.8 mm
depth of groove t max. 3.0 mm

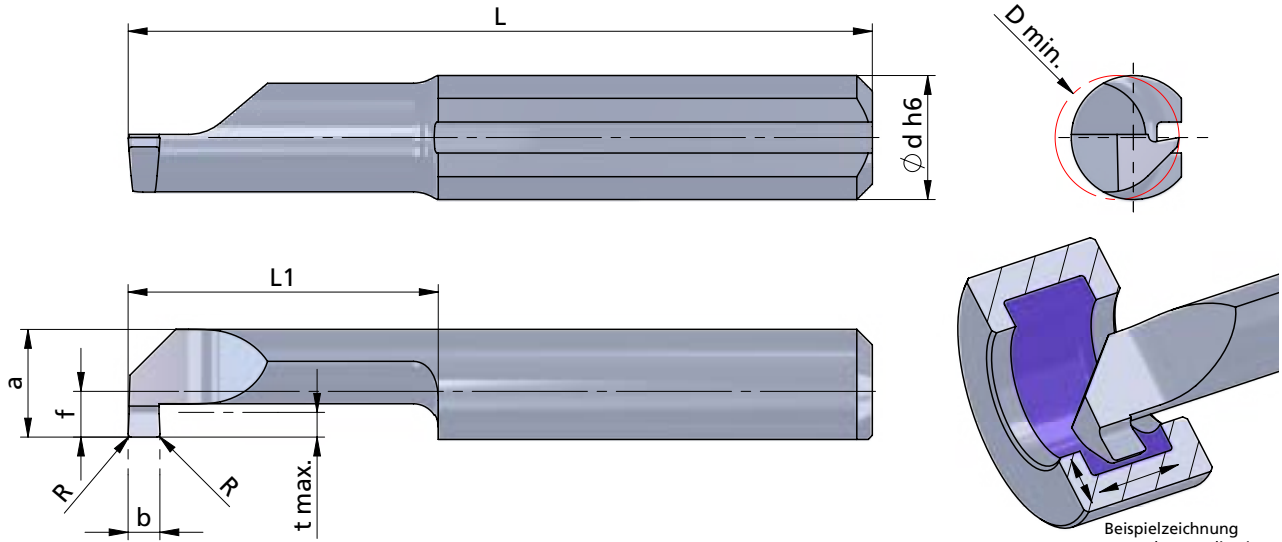

Rechts (R): wie gezeichnet
Links (L): spiegelbildlich

righthand (R): as shown
lefthand version (L): mirror image

Abmessungen in mm

dimensions in mm

Bestellnummer part number	b +0.05	R	f	a	L	L1	t max.	D min.	Ø d h6	Klemmhalter Typ toolholder type			
										K10F	CN45F	AL41F	P07C
R/L 008M0100-30	1.0	0.1	3.3	7.3	50	30	3.0	7.8	8.0		●		
R/L 008M0100-40	1.0	0.1	3.3	7.3	60	40	3.0	7.8	8.0		●		
R/L 008M0200-30	2.0	0.1	3.3	7.3	50	30	3.0	7.8	8.0		●		680... 681... 687... ...8
R/L 008M0200-40	2.0	0.1	3.3	7.3	60	40	3.0	7.8	8.0		●		
R/L 008M0250-30	2.5	0.1	3.3	7.3	50	30	3.0	7.8	8.0		●		
R/L 008M0250-40	2.5	0.1	3.3	7.3	60	40	3.0	7.8	8.0		●		

Weitere HM Sorten können Sie in der Sortenübersicht im Kapitel "Technische Hinweise" und der Preisliste finden.

More carbide grades you can find in the grades summary in the chapter "technical instructions" and in the price list.

Bestellbeispiel:
für rechte Ausführung und Sorte
R008M0100-30/AL41F

order-example:
righthand version and grade
R008M0100-30/AL41F

ULTRAMINI

Bohrungsbearbeitung
ab \varnothing 0.2 mm

grooving, boring and profiling
starting at \varnothing 0.2 mm

Typ 10M

Stechdrehen
mit Eckenradius und
innerer Kühlmittelzufuhr

grooving
with corner radius and
with through coolant

D min. 10.5 mm
Stechtiefe t max. 4.0 mm

D min. 10.5 mm
depth of groove t max. 4.0 mm

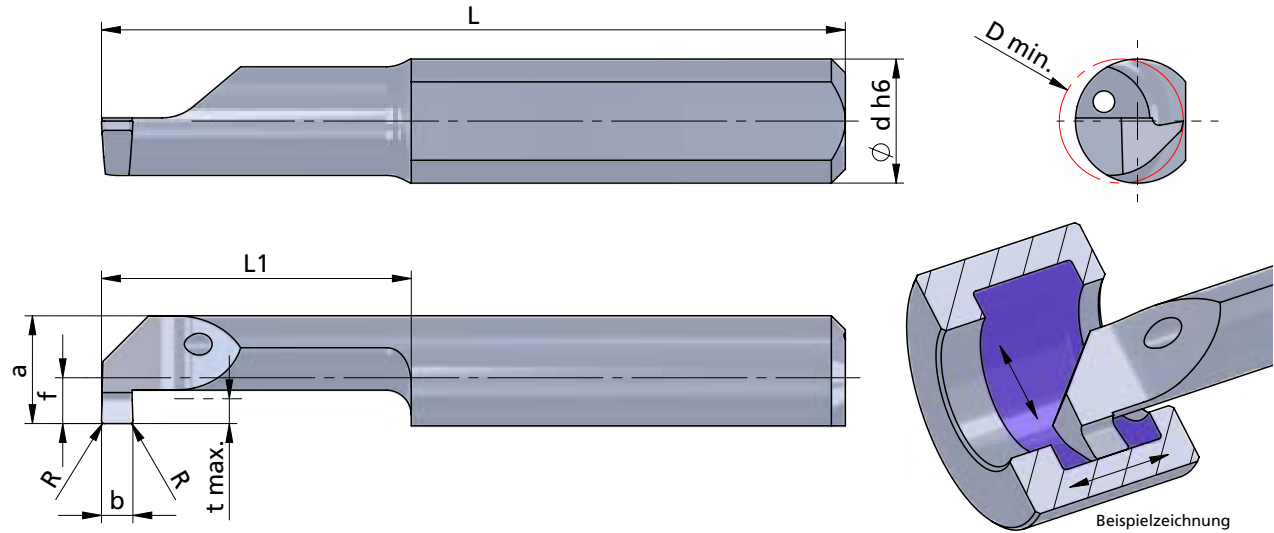

Rechts (R): wie gezeichnet
Links (L): spiegelbildlich

righthand (R): as shown
lefthand version (L): mirror image



Abmessungen in mm

dimensions in mm

Bestellnummer part number	b +0.05	R	f	a	L	L1	t max.	D min.	\varnothing d h6	Material				Klemmhalter Typ toolholder type
										K10F	CN45F	AL41F	P07C	
R/L 10M0100-30	1.0	0.1	4.9	9.9	57	30	4.0	10.5	10		●			681...
R/L 10M0100-50	1.0	0.1	4.9	9.9	77	50	4.0	10.5	10		●			
R/L 10M0200-30	2.0	0.1	4.9	9.9	57	30	4.0	10.5	10		●			
R/L 10M0200-50	2.0	0.1	4.9	9.9	77	50	4.0	10.5	10		●			
R/L 10M0300-30	3.0	0.1	4.9	9.9	57	30	4.0	10.5	10		●			
R/L 10M0300-50	3.0	0.1	4.9	9.9	77	50	4.0	10.5	10		●			

Weitere HM Sorten können Sie in der Sortenübersicht im Kapitel "Technische Hinweise" und der Preisliste finden.

Bestellbeispiel:
für rechte Ausführung und Sorte
R10M0100-30/AL41F

More carbide grades you can find in the grades summary in the chapter "technical instructions" and in the price list.

order-example:
righthand version and grade
R10M0100-30/AL41F

ULTRAMINI

Bohrungsbearbeitung
ab \varnothing 0.2 mm

grooving, boring and profiling
starting at \varnothing 0.2 mm

Typ 004 / 005 / 006 / 007

Stechdrehen und Kopieren
mit Vollradius

grooving and profiling
with full radius

D min. 4.0 mm
Vollradius R 0.5 - 1.0

D min. 4.0 mm
full radius R 0.5 - 1.0

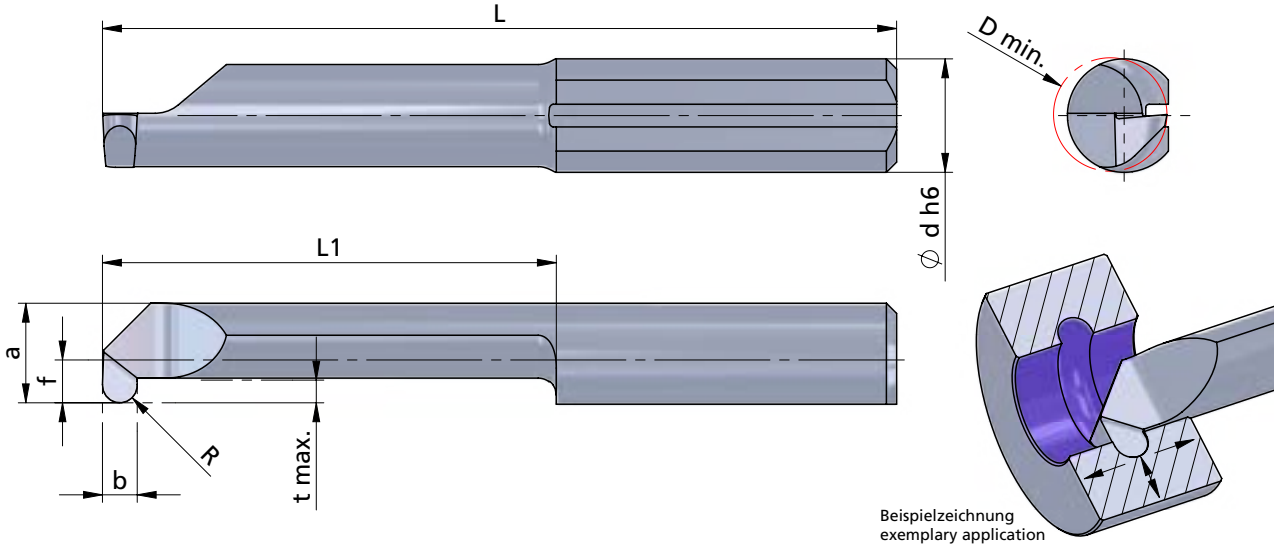
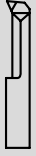

Rechts (R): wie gezeichnet
Links (L): spiegelbildlich

righthand (R): as shown
lefthand version (L): mirror image

Abmessungen in mm

dimensions in mm

Bestellnummer part number	b +0.05	b (inch)	R	f	a	L	L1	t max.	D min.	\varnothing d h6	Klemmhalter Typ				Klemmhalter Typ	toolholder type
											K10F	CN45F	AL41F	PD2F		
R/L 004-0.50-16	1.0		0.5	1.5	3.5	30	16	0.8	4.0	4.0	●	●	●			640... ...4
R/L 005-0.50-20	1.0		0.5	1.9	4.4	35	20	1.0	5.0	5.0		●	●	645...		
R/L 005-0.58-20	1.17	0.046"	0.585	1.9	4.4	35	20	1.0	5.0	5.0		●	●	645...		650... ...5
R/L 005-0.75-20	1.5		0.75	1.9	4.4	35	20	1.0	5.0	5.0		●	●	645...		
R/L 005-1.00-20	2.0		1.0	1.9	4.4	35	20	1.0	5.0	5.0		●	●	645...		
R/L 006-0.50-25	1.0		0.5	2.3	5.3	40	25	1.8	6.0	6.0	●	●	●			
R/L 006-0.75-25	1.5		0.75	2.3	5.3	40	25	1.8	6.0	6.0	●	●	●			660... ...6
R/L 006-1.00-25	2.0		1.0	2.3	5.3	40	25	1.8	6.0	6.0	●	●	●	676...		
R/L 007-0.50-30	1.0		0.5	2.8	6.3	45	30	2.5	6.8	7.0		●	●	676...		
R/L 007-0.75-30	1.5		0.75	2.8	6.3	45	30	2.5	6.8	7.0		●	●	676...		670... 687... ...7
R/L 007-1.00-30	2.0		1.0	2.8	6.3	45	30	2.5	6.8	7.0		●	●	676...		

Weitere HM Sorten können Sie in der Sortenübersicht im Kapitel "Technische Hinweise" und der Preisliste finden.

More carbide grades you can find in the grades summary in the chapter "technical instructions" and in the price list.

Bestellbeispiel:
für rechte Ausführung und Sorte
R004-0.50-16/AL41F

order-example:
righthand version and grade
R004-0.50-16/AL41F

ULTRAMINI

Bohrungsbearbeitung
ab \varnothing 0.2 mm

grooving, boring and profiling
starting at \varnothing 0.2 mm

Typ P04 / P05 / P06 / P07

Stechdrehen und Kopieren
mit Vollradius
und innerer Kühlmittelzufuhr

grooving and profiling
with full radius
and through coolant

Performanceline

D min. 4.0 mm
Vollradius R 0.5 - 1.0

D min. 4.0 mm
full radius R 0.5 - 1.0

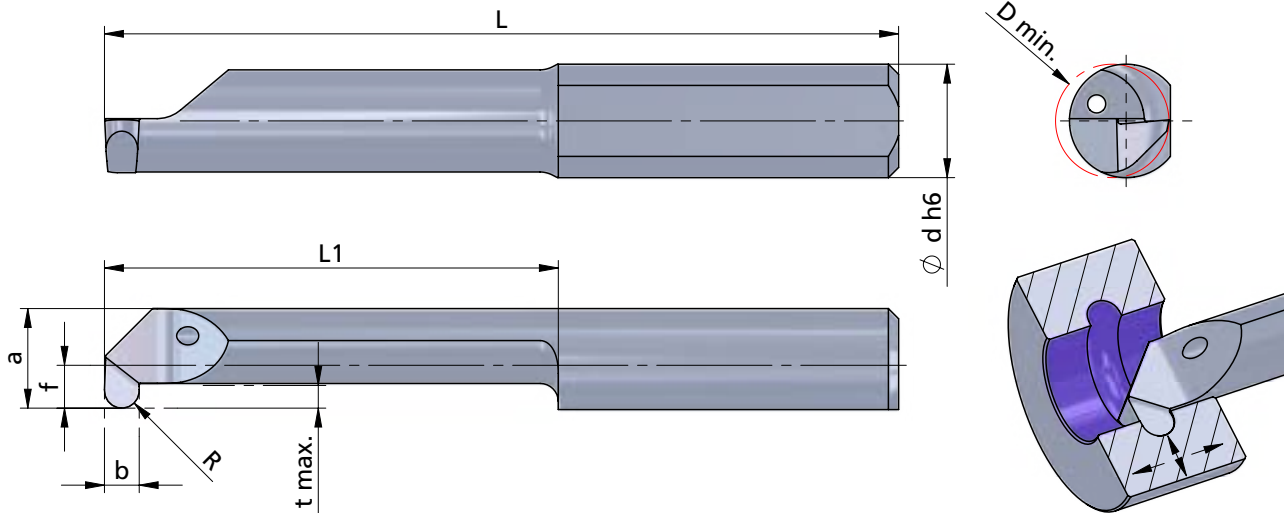

Beispielzeichnung
exemplary application

Rechts (R): wie gezeichnet
Links (L): spiegelbildlich

righthand (R): as shown
lefthand version (L): mirror image

Abmessungen in mm

dimensions in mm



Bestellnummer part number	b +0.05	b (inch)	R	f	a	L	L1	t max.	D min.	Ø d h6	K10F P04C AL41F PD2F	Klemmhalter Typ	toolholder type		
R/L P04-0.50-16	1.0		0.5	1.5	3.5	30	16	0.8	4.0	4.0	●	645...	640...	...4	
R/L P05-0.50-20	1.0		0.5	1.9	4.4	35	20	1.0	5.0	5.0	●		650...	...5	
R/L P05-0.58-20	1.17	0.046"	0.585	1.9	4.4	35	20	1.0	5.0	5.0	●				
R/L P05-0.75-20	1.5		0.75	1.9	4.4	35	20	1.0	5.0	5.0	●				
R/L P05-1.00-20	2.0		1.0	1.9	4.4	35	20	1.0	5.0	5.0	●	676...	660...	...6	
R/L P06-0.50-25	1.0		0.5	2.3	5.3	40	25	1.8	6.0	6.0	●		670...	687...	...7
R/L P06-0.75-25	1.5		0.75	2.3	5.3	40	25	1.8	6.0	6.0	●				
R/L P06-1.00-25	2.0		1.0	2.3	5.3	40	25	1.8	6.0	6.0	●				
R/L P07-0.50-30	1.0		0.5	2.8	6.3	45	30	2.5	6.8	7.0	●				
R/L P07-0.75-30	1.5		0.75	2.8	6.3	45	30	2.5	6.8	7.0	●				
R/L P07-1.00-30	2.0		1.0	2.8	6.3	45	30	2.5	6.8	7.0	●				

Weitere HM Sorten können Sie in der Sortenübersicht im Kapitel "Technische Hinweise" und der Preisliste finden.

Bestellbeispiel:
für rechte Ausführung und Sorte
RP04-0.50-16/P04C

More carbide grades you can find in the grades summary in the chapter "technical instructions" and in the price list.

order-example:
righthand version and grade
RP04-0.50-16/P04C

ULTRAMINI

Bohrungsbearbeitung
ab Ø 0.2 mm

grooving, boring and profiling
starting at Ø 0.2 mm

Typ 060

Ausdrehen und Fasen

D min. 3.0 - 6.8 mm

boring and chamfering

D min. 3.0 - 6.8 mm

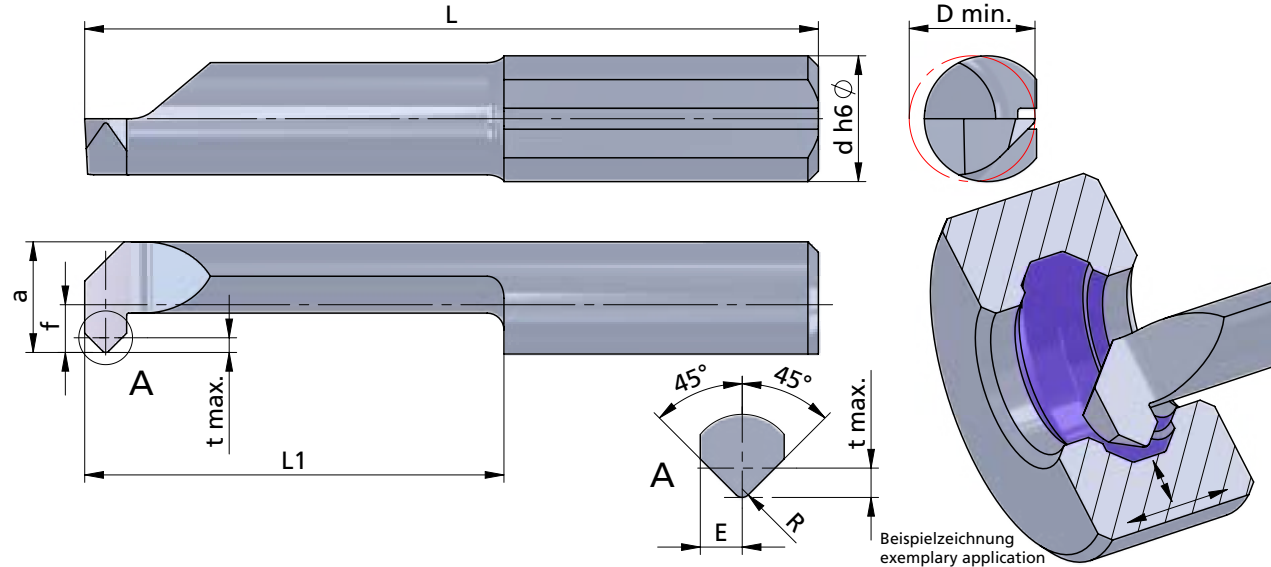

Rechts (R): wie gezeichnet
Links (L): spiegelbildlich

righthand (R): as shown
lefthand version (L): mirror image

Abmessungen in mm

dimensions in mm

Bestellnummer part number	E	R	f	a	L	L1	t max.	D min.	Ø d h6	K10F	CN45F	AL41F	P07C	Klemmhalter Typ	toolholder type
R/L 060.3-10	0.6	0.2	0.7	2.7	24	10	0.4	3.0	4	●	●	●		645...	640... ...4
R/L 060.4-16	0.75	0.2	1.5	3.5	30	16	0.5	4.0	4	●	●	●			650... ...5
R/L 060.5-15	1	0.2	1.9	4.4	30	15	0.7	5.0	5	●	●	●		676...	660... ...6
R/L 060.5-20	1	0.2	1.9	4.4	35	20	0.7	5.0	5	●	●	●			670... 687... ...7
R/L 060.6-20	1	0.2	2.3	5.3	35	20	0.7	6.0	6	●	●	●			
R/L 060.6-25	1	0.2	2.3	5.3	40	25	0.7	6.0	6	●	●	●			
R/L 060.7-20	1	0.2	2.8	6.3	35	20	0.7	6.8	7	●	●	●			
R/L 060.7-40	1	0.2	2.8	6.3	55	40	0.7	6.8	7	●	●	●			

Weitere HM Sorten können Sie in der Sortenübersicht im Kapitel "Technische Hinweise" und der Preisliste finden.

More carbide grades you can find in the grades summary in the chapter "technical instructions" and in the price list.

Bestellbeispiel:
für rechte Ausführung und Sorte
R060.5-15/AL41F

order-example:
righthand version and grade
R060.5-15/AL41F

ULTRAMINI

Bohrungsbearbeitung
ab $\varnothing 0.2$ mm

grooving, boring and profiling
starting at $\varnothing 0.2$ mm

Typ P60

Ausdrehen und Fasen
mit innerer Kühlmittelzufuhr

boring and chamfering
with through coolant

Performanceline

D min. 3.0 - 6.8 mm

D min. 3.0 - 6.8 mm

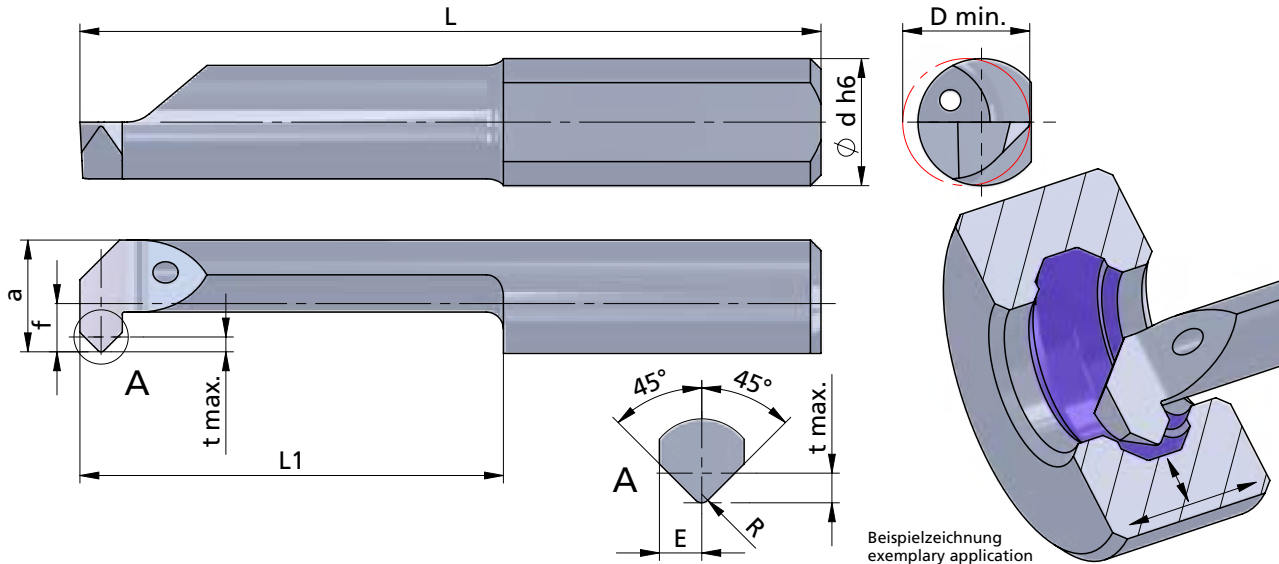

Rechts (R): wie gezeichnet
Links (L): spiegelbildlich

righthand (R): as shown
lefthand version (L): mirror image

Abmessungen in mm

dimensions in mm



Bestellnummer part number	E	R	f	a	L	L1	t max.	D min.	Ø d h6	K10F P04C AL41F P07C	Klemmhalter Typ	toolholder type
R/L P60.3-10	0.6	0.2	0.7	2.7	24	10	0.4	3.0	4	●	645...	640... ...4
R/L P60.4-16	0.75	0.2	1.5	3.5	30	16	0.5	4.0	4	●		650... ...5
R/L P60.5-15	1	0.2	1.9	4.4	30	15	0.7	5.0	5	●	676...	660... ...6
R/L P60.5-20	1	0.2	1.9	4.4	35	20	0.7	5.0	5	●		670... 687... ...7
R/L P60.6-20	1	0.2	2.3	5.3	35	20	0.7	6.0	6	●		
R/L P60.6-25	1	0.2	2.3	5.3	40	25	0.7	6.0	6	●		
R/L P60.7-20	1	0.2	2.8	6.3	35	20	0.7	6.8	7	●		
R/L P60.7-40	1	0.2	2.8	6.3	55	40	0.7	6.8	7	●		

Weitere HM Sorten können Sie in der Sortenübersicht im Kapitel "Technische Hinweise" und der Preisliste finden.

Bestellbeispiel:
für rechte Ausführung und Sorte
RP60.3-10/P04C

More carbide grades you can find in the grades summary in the chapter "technical instructions" and in the price list.

order-example:
righthand version and grade
RP60.3-10/P04C

ULTRAMINI

Bohrungsbearbeitung
ab $\varnothing 0.2$ mm

grooving, boring and profiling
starting at $\varnothing 0.2$ mm

Typ 070

Vorstechen und Fasen

D min. 4.0 - 6.0 mm

pregrooving and chamfering

D min. 4.0 - 6.0 mm

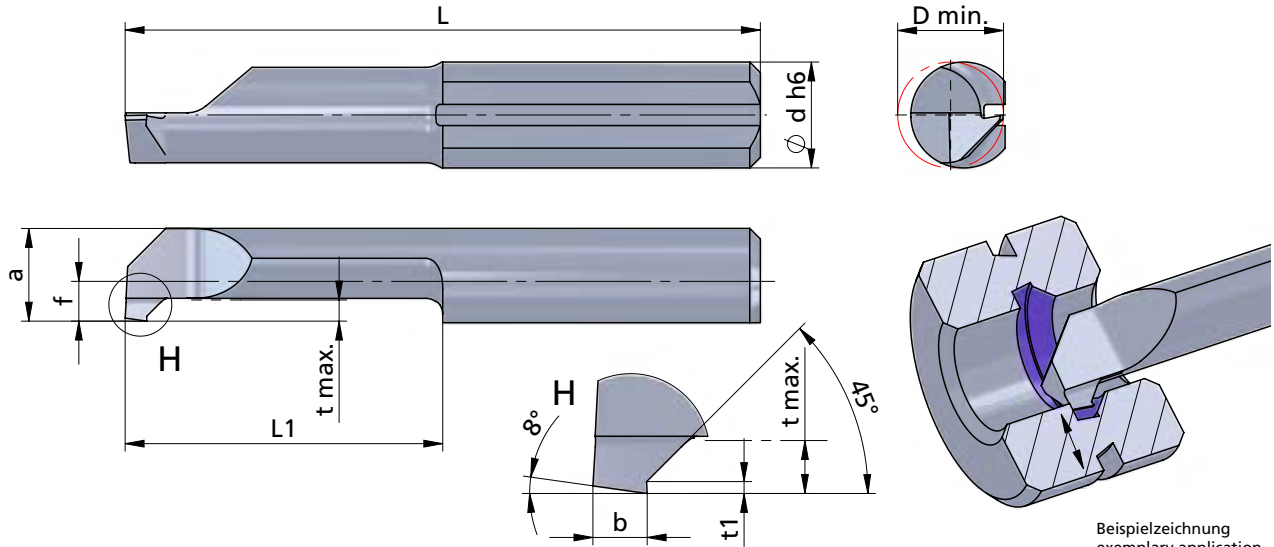
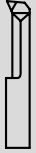

Rechts (R): wie gezeichnet
Links (L): spiegelbildlich

righthand (R): as shown
lefthand version (L): mirror image

Abmessungen in mm

dimensions in mm

Bestellnummer part number	t1	b	f	a	L	L1	t max.	D min.	Ø d h6	K10F CN45F AL41F P07C	Klemmhalter Typ	toolholder type
											645...	640... ...4 650... ...5
R/L 070.4-10	0.2	1.0	1.5	3.5	25	10	0.8	4.0	4.0	● ● ●	645...	640... ...4
R/L 070.4-16	0.2	1.0	1.5	3.5	30	16	0.8	4.0	4.0	● ● ●		650... ...5
R/L 070.5-15	0.2	1.0	1.9	4.4	30	15	1.0	5.0	5.0	● ● ●	645...	650... ...5
R/L 070.5-20	0.2	1.0	1.9	4.4	35	20	1.0	5.0	5.0	● ● ●		
R/L 070.5-30	0.2	1.0	1.9	4.4	45	30	1.0	5.0	5.0	● ● ●		
R/L 070.6-30	0.2	1.0	2.3	5.3	45	30	1.0	6.0	6.0	● ● ●	660... 676... ...6	
R/L 070.6-42	0.2	1.0	2.3	5.3	57	42	1.0	6.0	6.0	● ● ●		

Weitere HM Sorten können Sie in der Sortenübersicht im Kapitel "Technische Hinweise" und der Preisliste finden.

More carbide grades you can find in the grades summary in the chapter "technical instructions" and in the price list.

Bestellbeispiel:
für rechte Ausführung und Sorte
R070.4-10/AL41F

order-example:
righthand version and grade
R070.4-10/AL41F

ULTRAMINI

Bohrungsbearbeitung
ab $\varnothing 0.2$ mm

grooving, boring and profiling
starting at $\varnothing 0.2$ mm

Typ P70

Vorstechen und Fasen
mit innerer Kühlmittelzufuhr

pregrooving and chamfering
with through coolant

Performanceline

D min. 4.0 - 6.0 mm

D min. 4.0 - 6.0 mm

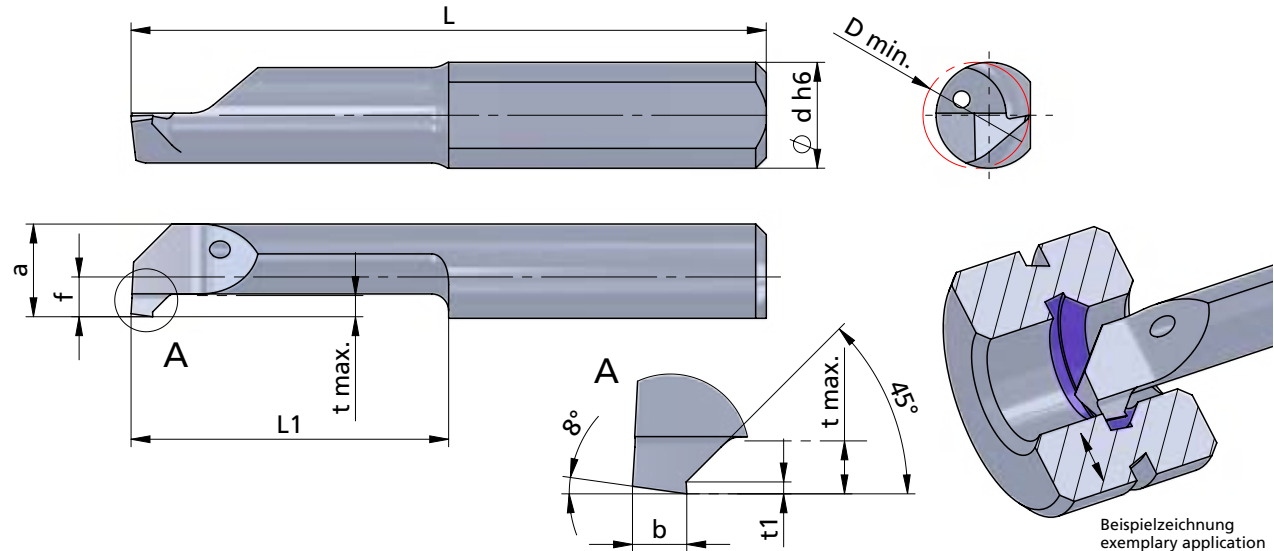

Beispielzeichnung
exemplary application

Rechts (R): wie gezeichnet
Links (L): spiegelbildlich

righthand (R): as shown
lefthand version (L): mirror image



Abmessungen in mm

dimensions in mm

Bestellnummer part number	t1	b	f	a	L	L1	t max.	D min.	\varnothing d h6	K10F	P04C	AL41F	P07C	Klemmhalter Typ toolholder type	
														645...	640... ...4
R/L P70.4-10	0.2	1.0	1.5	3.5	25	10	0.8	4.0	4.0	●					
R/L P70.4-16	0.2	1.0	1.5	3.5	30	16	0.8	4.0	4.0	●					
R/L P70.5-15	0.2	1.0	1.9	4.4	30	15	1.0	5.0	5.0	●				645...	640... ...4
R/L P70.5-20	0.2	1.0	1.9	4.4	35	20	1.0	5.0	5.0	●					
R/L P70.5-30	0.2	1.0	1.9	4.4	45	30	1.0	5.0	5.0	●					650... ...5
R/L P70.6-30	0.2	1.0	2.3	5.3	45	30	1.0	6.0	6.0	●					
R/L P70.6-42	0.2	1.0	2.3	5.3	57	42	1.0	6.0	6.0	●				660... 676... ...6	

Weitere HM Sorten können Sie in der Sortenübersicht im Kapitel "Technische Hinweise" und der Preisliste finden.

Bestellbeispiel:
für rechte Ausführung und Sorte
RP70.4-10/P04C

More carbide grades you can find in the grades summary in the chapter "technical instructions" and in the price list.

order-example:
righthand version and grade
RP70.4-10/P04C

ULTRAMINI

Bohrungsbearbeitung
ab \varnothing 0.2 mm

grooving, boring and profiling
starting at \varnothing 0.2 mm

Impressionen

impressions



ULTRAMINI

Bohrungsbearbeitung
ab $\varnothing 0.2 \text{ mm}$

grooving, boring and profiling
starting at $\varnothing 0.2 \text{ mm}$

Typ Gewindedrehen

metrisches ISO-Gewinde,
Teilprofil, innen

D min. 0.73 - 7.0 mm
Steigung P = 0.25 - 1.75

type threading,
metric ISO-thread,
partial profile, internal

D min. 0.73 - 7.0 mm
pitch P = 0.25 - 1.75

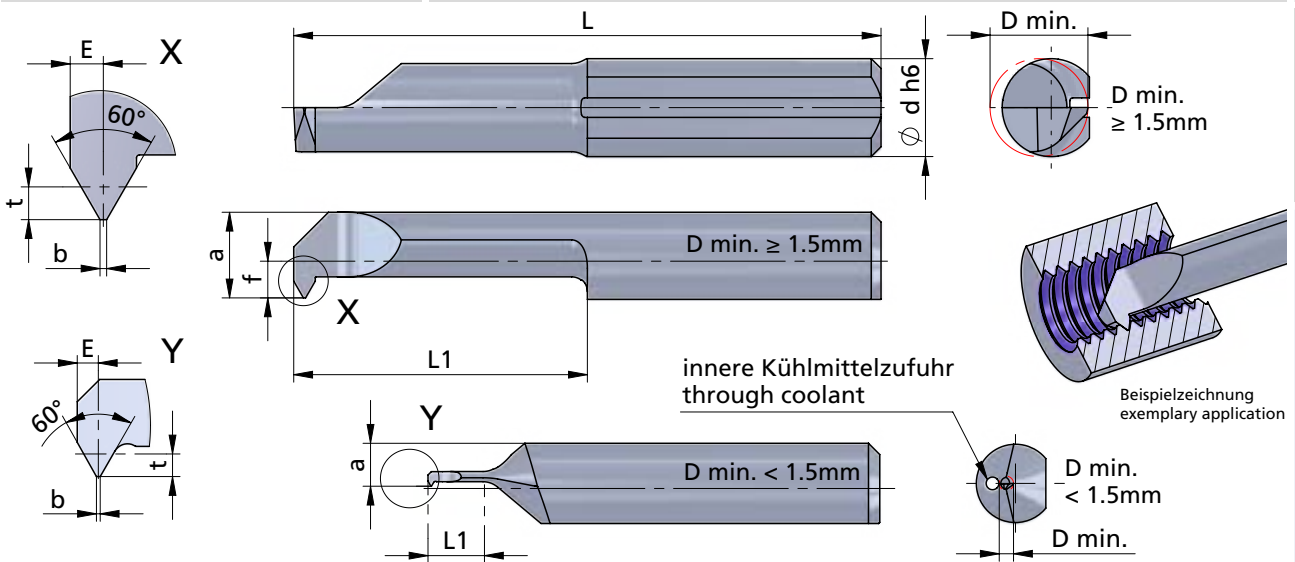

Rechts (R): wie gezeichnet
Links (L): spiegelbildlich

righthand (R): as shown
lefthand version (L): mirror image

**nicht normgerecht
Abmessungen in mm

**not according to ISO
dimensions in mm

*
D min.
< 1.5mm



Bestellnummer part number	Steigung P pitch P	Regelgewinde / standard thread								D min.	Ø d h6	K10F CN45F AL41F PD2F	Klemmhalter Typ toolholder type
			t	E	b	f	a	L	L1				
R/L 001.01025-3*	0.25 - 0.3	M1	0.135	0.14	0.03	-0.10	0.65	20	2.5	0.73	4.0	●	645... 640... ...4
R/L 001.02035-4*	0.35 - 0.4	M1.6	0.189	0.18	0.04	0.35	1.1	20	4.0	1.22	4.0	●	
R/L 002.0204-5	0.4 - 0.45	M2	0.22	0.2	0.05	-0.60	1.4	20	5	1.56	4.0	●	
R/L 002.02045-6	0.45 - 0.5	M2.5	0.24	0.22	0.06	-0.55	1.45	22	6	1.7	4.0	●	
R/L 003.0105-8	0.5 - 0.7	M3	0.27	0.33	0.04**	0.30	2.3	22	8	2.4	4.0	●	
R/L 004.0105-10	0.5 - 0.75		0.27	0.44	0.09**	1.00	3.0	24	10	3.2	4.0	●	
R/L 004.0105-12	0.5 - 0.75		0.27	0.35	0.06	1.00	3.0	26	12	3.2	4.0	●	
R/L 004.0307-10	0.7 - 0.8	M4	0.38	0.32	0.09	0.90	2.9	24	10	3.2	4.0	●	
R/L 004.0205-15	0.5 - 0.75		0.27	0.35	0.06	1.50	3.5	30	15	4.0	4.0	●	
R/L 004.0408-15	0.8 - 1.0	M5	0.43	0.45	0.10	1.50	3.5	30	15	4.0	4.0	●	
↳ ...													

Weitere HM Sorten können Sie in der Sortenübersicht im Kapitel "Technische Hinweise" und der Preisliste finden.

Bestellbeispiel:
für rechte Ausführung und Sorte
R001.01025-3/AL41F

weitere Informationen:
• siehe Technische Hinweise

more informations:
• look at the technical instructions

More carbide grades you can find in the grades summary in the chapter "technical instructions" and in the price list.

order-example:
righthand version and grade
R001.01025-3/AL41F

ULTRAMINI

Bohrungsbearbeitung
ab \varnothing 0.2 mm

grooving, boring and profiling
starting at \varnothing 0.2 mm

Typ Gewindedrehen

metrisches ISO-Gewinde,
Teilprofil, innen

type threading,
metric ISO-thread,
partial profile, internal

D min. 0.73 - 7.0 mm
Steigung P = 0.25 - 1.75

D min. 0.73 - 7.0 mm
pitch P = 0.25 - 1.75

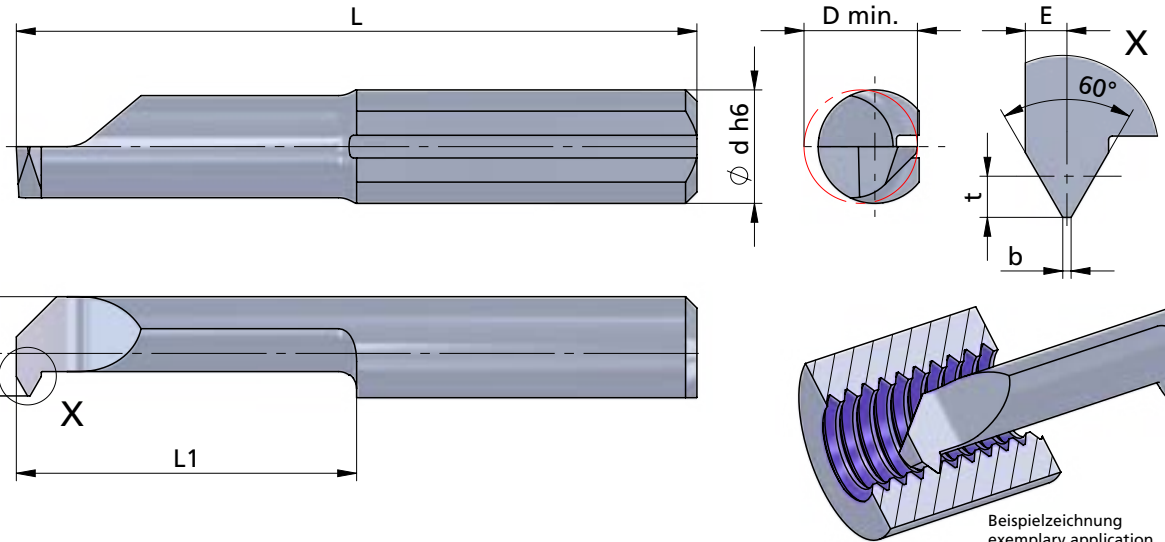
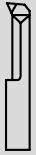

Beispielzeichnung
exemplary application

Rechts (R): wie gezeichnet
Links (L): spiegelbildlich

righthand (R): as shown
lefthand version (L): mirror image

Abmessungen in mm

dimensions in mm

Bestellnummer part number	Steigung P pitch P	Regelgewinde / standard thread									D min.	\varnothing d h6	Klemmhalter Typ				Klemmhalter Typ toolholder type
			t	E	b	f	a	L	L1	K10F			CN45F	AL41F	PD2F		
⋮ ↘																	
R/L 005.0205-15	0.5 - 0.75		0.27	0.35	0.06	1.9	4.4	30	15	5.0	5.0	●	●				
R/L 005.0205-20	0.5 - 0.75		0.27	0.35	0.06	1.9	4.4	35	20	5.0	5.0	●	●				
R/L 005.0205-25	0.5 - 0.75		0.27	0.35	0.06	1.9	4.4	40	25	5.0	5.0			●			
R/L 005.0407-15	0.75 - 1.0		0.4	0.45	0.09	1.9	4.4	30	15	5.0	5.0	●	●				
R/L 005.0407-20	0.75 - 1.0		0.4	0.45	0.09	1.9	4.4	35	20	5.0	5.0	●	●				
R/L 005.0510-15	1.0 - 1.25	M6	0.55	0.55	0.12	1.9	4.4	30	15	5.0	5.0	●	●				
R/L 005.0510-20	1.0 - 1.25	M6	0.55	0.55	0.12	1.9	4.4	35	20	5.0	5.0	●	●				
R/L 005.0510-25	1.0 - 1.25	M6	0.55	0.55	0.12	1.9	4.4	40	25	5.0	5.0			●			
↙ ⋮																	

645...
650...
...5

Weitere HM Sorten können Sie in der Sortenübersicht im Kapitel "Technische Hinweise" und der Preisliste finden.

weitere Informationen:
• siehe Technische Hinweise

More carbide grades you can find in the grades summary in the chapter "technical instructions" and in the price list.

Bestellbeispiel:
für rechte Ausführung und Sorte
R005.0205-15/AL41F

more informations:
• look at the technical instructions

order-example:
righthand version and grade
R005.0205-15AL41F

ULTRAMINI

Bohrungsbearbeitung
ab \varnothing 0.2 mm

grooving, boring and profiling
starting at \varnothing 0.2 mm

Typ Gewindedrehen

metrisches ISO-Gewinde,
Teilprofil, innen

type threading,
metric ISO-thread,
partial profile, internal

D min. 0.73 - 7.0 mm
Steigung P = 0.25 - 1.75

D min. 0.73 - 7.0 mm
pitch P = 0.25 - 1.75

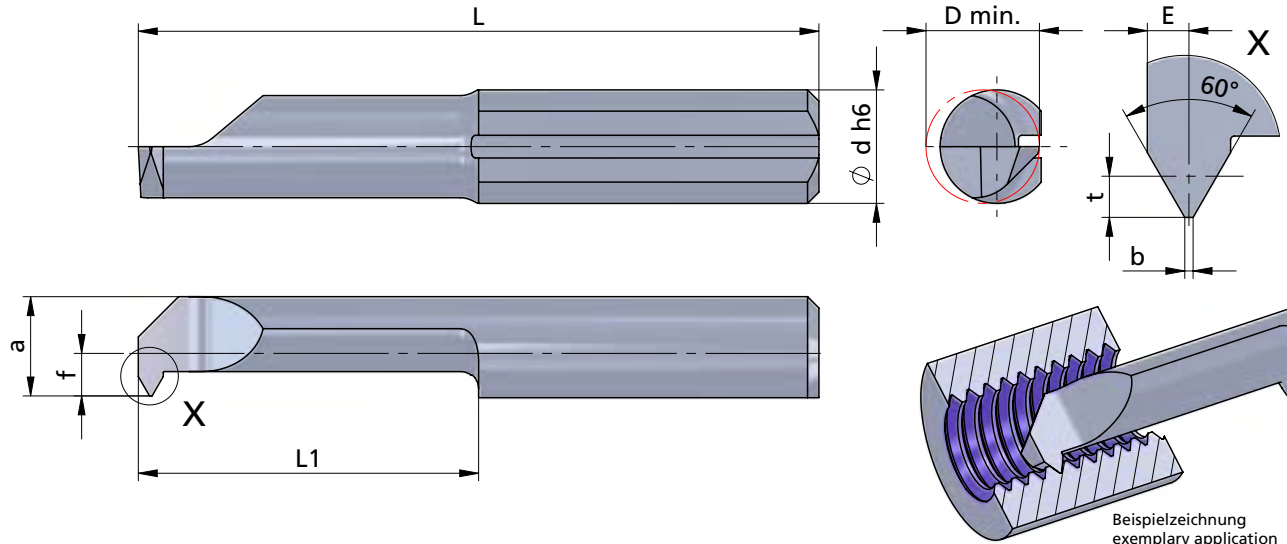

Beispielzeichnung
exemplary application

Rechts (R): wie gezeichnet
Links (L): spiegelbildlich

righthand (R): as shown
lefthand version (L): mirror image

Abmessungen in mm

dimensions in mm

Bestellnummer part number	Steigung P pitch P	Regelgewinde / standard thread	t	E	b	f	a	L	L1	D min.	\varnothing d h6	Klemmhalter Typ				Klemmhalter Typ toolholder type
												K10F	CN45F	AL41F	PD2F	
R/L 006.0510-15	1.0 - 1.25		0.55	0.55	0.12	2.3	5.3	30	15	6.0	6.0	●	●			
R/L 006.0510-22	1.0 - 1.25		0.55	0.55	0.12	2.3	5.3	37	22	6.0	6.0	●	●			
R/L 006.0612-15	1.25 - 1.5	M8	0.68	0.65	0.15	2.3	5.3	30	15	6.0	6.0	●	●			
R/L 006.0612-22	1.25 - 1.5	M8	0.68	0.65	0.15	2.3	5.3	37	22	6.0	6.0	●	●			660... ...6
R/L 006.0612-30	1.25 - 1.5	M8	0.68	0.65	0.15	2.3	5.3	45	30	6.0	6.0		●			
R/L 006.0815-15	1.5 - 1.75	M10	0.81	0.75	0.18	2.3	5.3	30	15	6.0	6.0	●	●			
R/L 006.0815-22	1.5 - 1.75	M10	0.81	0.75	0.18	2.3	5.3	37	22	6.0	6.0	●	●			
R/L 007.0815-15	1.5 - 1.75	M10	0.81	0.75	0.18	2.8	6.3	30	15	7.0	7.0	●	●			670... 687... ...7
R/L 007.0815-25	1.5 - 1.75	M10	0.81	0.75	0.18	2.8	6.3	40	25	7.0	7.0	●	●			

Weitere HM Sorten können Sie in der Sortenübersicht im Kapitel "Technische Hinweise" und der Preisliste finden.

Bestellbeispiel:
für rechte Ausführung und Sorte
R006.0510-15/AL41F

weitere Informationen:

- siehe Technische Hinweise

more informations:

- look at the technical instructions

More carbide grades you can find in the grades summary in the chapter "technical instructions" and in the price list.

order-example:
righthand version and grade
R006.0510-15AL41F

ULTRAMINI

Bohrungsbearbeitung
ab \varnothing 0.2 mm

grooving, boring and profiling
starting at \varnothing 0.2 mm

Typ Gewindedrehen

metrisches ISO-Gewinde,
Teilprofil, innen
mit innerer Kühlmittelzufuhr

type threading,
metric ISO-thread,
partial profile, internal
with through coolant

Performanceline

D min. 1.56 - 7.0 mm
Steigung P = 0.4 - 1.75

D min. 1.56 - 7.0 mm
pitch P = 0.4 - 1.75

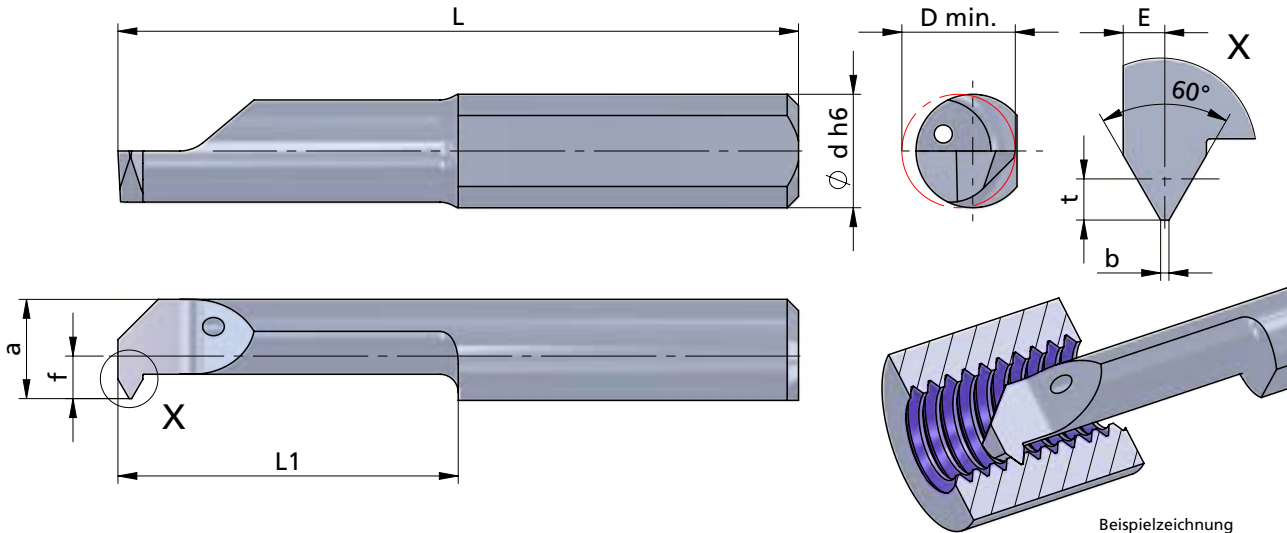

Beispielzeichnung
exemplary application

Rechts (R): wie gezeichnet
Links (L): spiegelbildlich

righthand (R): as shown
lefthand version (L): mirror image

*nicht normgerecht

*not according to ISO

Abmessungen in mm

dimensions in mm



Bestellnummer part number	Steigung P pitch P	Regelgewinde / standard thread								D min.	Ø d h6	Klemmhalter Typ toolholder type				
			t	E	b	f	a	L	L1			K10F	P04C	AL41F	PD2F	
R/L P02.0204-5	0.4 - 0.45	M2	0.22	0.2	0.05	-0.60	1.4	20	5	1.56	4.0	●				
R/L P02.02045-6	0.45 - 0.5	M2.5	0.24	0.22	0.06	-0.55	1.45	22	6	1.7	4.0	●				
R/L P03.0105-8	0.5 - 0.7	M3	0.27	0.33	0.04*	0.30	2.3	22	8	2.4	4.0	●				
R/L P04.0105-10	0.5 - 0.75		0.27	0.44	0.09*	1.00	3.0	24	10	3.2	4.0	●				
R/L P04.0307-10	0.7 - 0.8	M4	0.38	0.32	0.09	0.90	2.9	24	10	3.2	4.0	●				645... 640... ...4
R/L P04.0205-15	0.5 - 0.75		0.27	0.35	0.06	1.50	3.5	30	15	4.0	4.0	●				
R/L P04.0408-15	0.8 - 1.0	M5	0.43	0.45	0.10	1.50	3.5	30	15	4.0	4.0	●				
↳ ...																

Weitere HM Sorten können Sie in der Sortenübersicht im Kapitel "Technische Hinweise" und der Preisliste finden.

weitere Informationen:

- siehe Technische Hinweise

More carbide grades you can find in the grades summary in the chapter "technical instructions" and in the price list.

more informations:

- look at the technical instructions

order-example:
righthand version and grade
RP02.0204-5/P04C

Bestellbeispiel:
für rechte Ausführung und Sorte
RP02.0204-5/P04C

ULTRAMINI

Bohrungsbearbeitung
ab \varnothing 0.2 mm

grooving, boring and profiling
starting at \varnothing 0.2 mm

Typ Gewindedrehen

metrisches ISO-Gewinde,
Teilprofil, innen
mit innerer Kühlmittelzufuhr

type threading,
metric ISO-thread,
partial profile, internal
with through coolant

Performanceline

D min. 1.56 - 7.0 mm
Steigung P = 0.4 - 1.75

D min. 1.56 - 7.0 mm
pitch P = 0.4 - 1.75

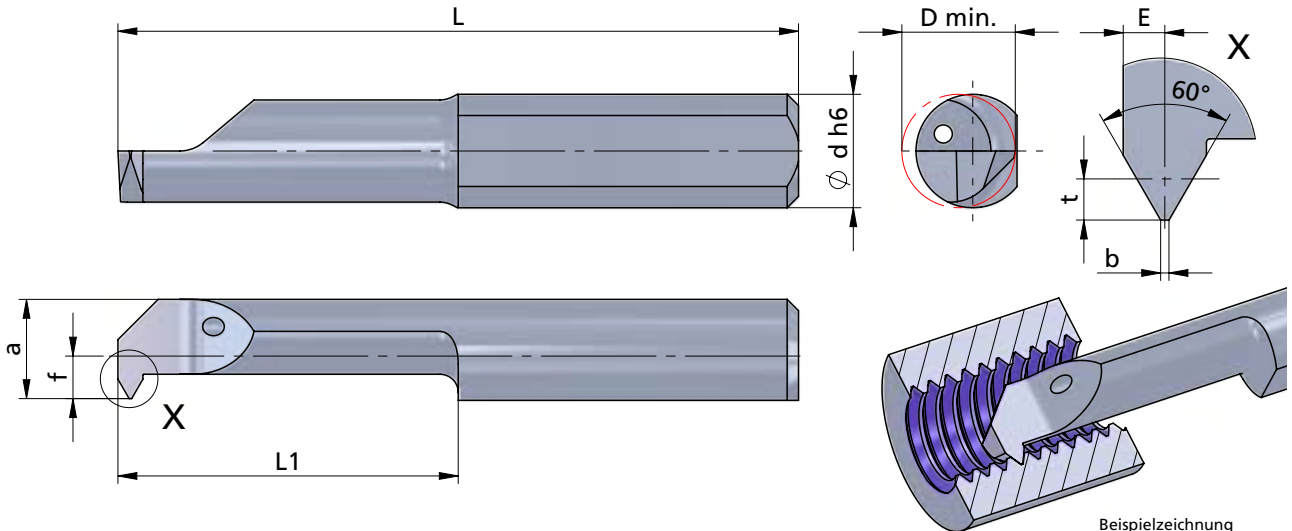

Beispielzeichnung
exemplary application

Rechts (R): wie gezeichnet
Links (L): spiegelbildlich

righthand (R): as shown
lefthand version (L): mirror image



Abmessungen in mm

dimensions in mm

Bestellnummer part number	Steigung P pitch P	Regelgewinde / standard thread									D min.	Ø d h6	Klemmhalter Typ toolholder type				
			t	E	b	f	a	L	L1	K10F			P04C	AL41F	PD2F		
⋮ ↘																	
R/L P05.0205-15	0.5 - 0.75		0.27	0.35	0.06	1.9	4.4	30	15	5.0	5.0	●					
R/L P05.0205-20	0.5 - 0.75		0.27	0.35	0.06	1.9	4.4	35	20	5.0	5.0	●					
R/L P05.0407-15	0.75 - 1.0		0.4	0.45	0.09	1.9	4.4	30	15	5.0	5.0	●					
R/L P05.0407-20	0.75 - 1.0		0.4	0.45	0.09	1.9	4.4	35	20	5.0	5.0	●					645... 650... ...5
R/L P05.0510-15	1.0 - 1.25	M6	0.55	0.55	0.12	1.9	4.4	30	15	5.0	5.0	●					
R/L P05.0510-20	1.0 - 1.25	M6	0.55	0.55	0.12	1.9	4.4	35	20	5.0	5.0	●					
↙ ...																	

Weitere HM Sorten können Sie in der Sortenübersicht im Kapitel "Technische Hinweise" und der Preisliste finden.

Bestellbeispiel:
für rechte Ausführung und Sorte
RP05.0205-15/P04C

weitere Informationen:

- siehe Technische Hinweise

more informations:

- look at the technical instructions

More carbide grades you can find in the grades summary in the chapter "technical instructions" and in the price list.

order-example:
righthand version and grade
RP05.0205-15/P04C

ULTRAMINI

Bohrungsbearbeitung
ab \varnothing 0.2 mm

grooving, boring and profiling
starting at \varnothing 0.2 mm

Typ Gewindedrehen

metrisches ISO-Gewinde,
Teilprofil, innen
mit innerer Kühlmittelzufuhr

type threading,
metric ISO-thread,
partial profile, internal
with through coolant

Performanceline

D min. 1.56 - 7.0 mm
Steigung P = 0.4 - 1.75

D min. 1.56 - 7.0 mm
pitch P = 0.4 - 1.75

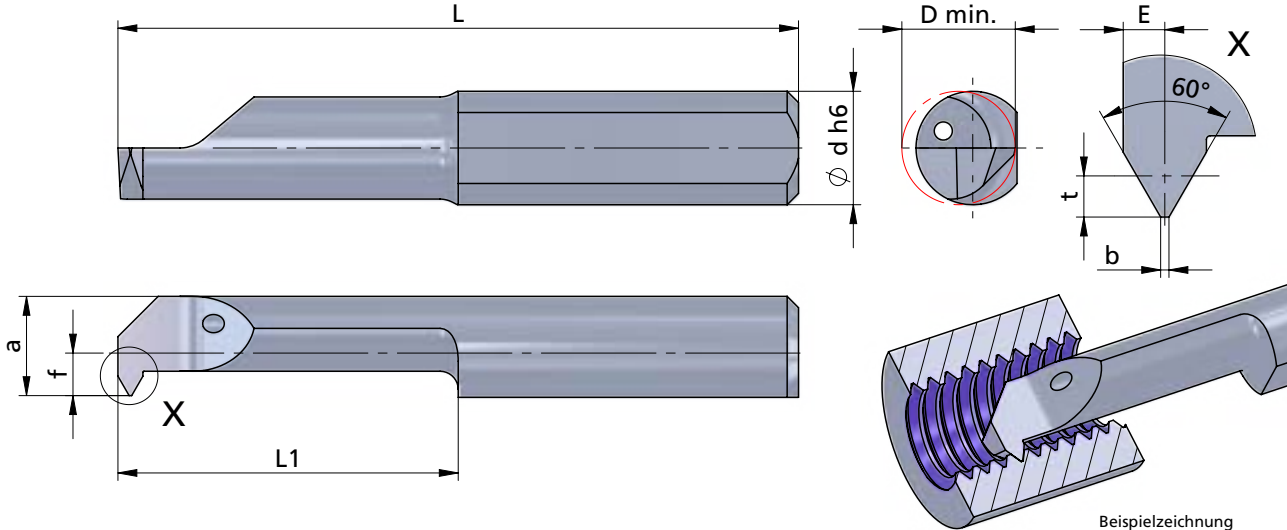

Beispielzeichnung
exemplary application

Rechts (R): wie gezeichnet
Links (L): spiegelbildlich

righthand (R): as shown
lefthand version (L): mirror image

Abmessungen in mm

dimensions in mm



Bestellnummer part number	Steigung P pitch P	Regelgewinde / standard thread	t	E	b	f	a	L	L1	D min.	Ø d h6	Klemmhalter Typ toolholder type				
												K10F	P04C	AL41F	PD2F	
⋮ ↘																
R/L P06.0510-15	1.0 - 1.25		0.55	0.55	0.12	2.3	5.3	30	15	6.0	6.0	●				
R/L P06.0510-22	1.0 - 1.25		0.55	0.55	0.12	2.3	5.3	37	22	6.0	6.0	●				
R/L P06.0612-15	1.25 - 1.5	M8	0.68	0.65	0.15	2.3	5.3	30	15	6.0	6.0	●				660... ...6
R/L P06.0612-22	1.25 - 1.5	M8	0.68	0.65	0.15	2.3	5.3	37	22	6.0	6.0	●				
R/L P06.0815-15	1.5 - 1.75	M10	0.81	0.75	0.18	2.3	5.3	30	15	6.0	6.0	●				
R/L P06.0815-22	1.5 - 1.75	M10	0.81	0.75	0.18	2.3	5.3	37	22	6.0	6.0	●				
R/L P07.0815-15	1.5 - 1.75	M10	0.81	0.75	0.18	2.8	6.3	30	15	7.0	7.0	●				670... 687... ...7
R/L P07.0815-25	1.5 - 1.75	M10	0.81	0.75	0.18	2.8	6.3	40	25	7.0	7.0	●				

Weitere HM Sorten können Sie in der Sortenübersicht im Kapitel "Technische Hinweise" und der Preisliste finden.

weitere Informationen:

- siehe Technische Hinweise

More carbide grades you can find in the grades summary in the chapter "technical instructions" and in the price list.

Bestellbeispiel:
für rechte Ausführung und Sorte
RP06.0510-15/P04C

more informations:

- look at the technical instructions

order-example:
righthand version and grade
RP06.0510-15/P04C

ULTRAMINI

Bohrungsbearbeitung
ab \varnothing 0.2 mm

grooving, boring and profiling
starting at \varnothing 0.2 mm

Typ Gewindedrehen

metrisches ISO-Gewinde,
Vollprofil, innen

type threading,
metric ISO-thread,
full profile, internal

D min. 2.4 - 7.0 mm
Steigung P = 0.5 - 1.5

D min. 2.4 - 7.0 mm
pitch P = 0.5 - 1.5

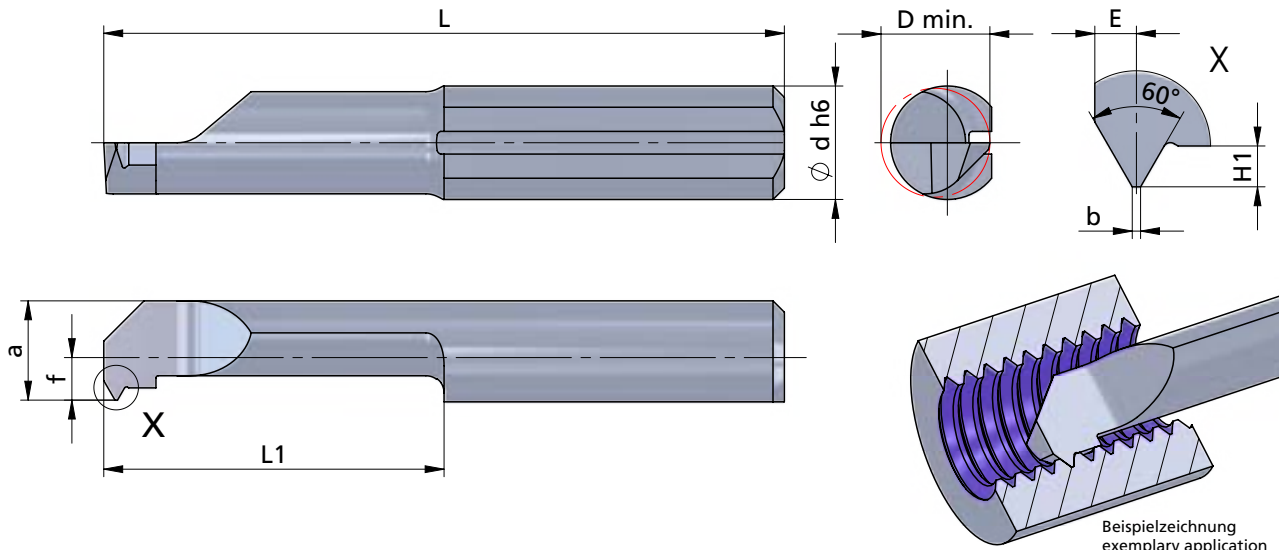

Beispielzeichnung
exemplary application

Rechts (R): wie gezeichnet
Links (L): spiegelbildlich

righthand (R): as shown
lefthand version (L): mirror image

Abmessungen in mm

dimensions in mm

Bestellnummer part number	Steigung P pitch P	Regelgewinde / standard thread	H1							D min.		\varnothing d h6	Klemmhalter Typ				Klemmhalter Typ toolholder type	
			H1	E	b	f	a	L	L1	K10F	CN45F		AL41F	PD2F				
R/L 102.0205-10	0.5	M3	0.27	0.24	0.06	0.2	2.2	25	10	2.4	4.0		●					
R/L 102.0205-15	0.5	M3	0.27	0.24	0.06	0.2	2.2	30	15	2.4	4.0		●					
R/L 103.0307-15	0.7	M4	0.38	0.32	0.09	0.9	2.9	30	15	3.2	4.0		●					
R/L 103.0307-20	0.7	M4	0.38	0.32	0.09	0.9	2.9	35	20	3.2	4.0		●					
R/L 104.0205-15	0.5		0.27	0.35	0.06	1.5	3.5	30	15	4.0	4.0		●					
R/L 104.0408-15	0.8	M5	0.43	0.5	0.10	1.5	3.5	30	15	4.0	4.0		●					
R/L 104.0408-25	0.8	M5	0.43	0.5	0.10	1.5	3.5	40	25	4.0	4.0		●					
R/L 105.0205-15	0.5		0.27	0.35	0.06	1.9	4.4	30	15	5.0	5.0		●					
R/L 105.0407-15	0.75		0.40	0.45	0.09	1.9	4.4	30	15	5.0	5.0		●					
R/L 105.0408-15	0.8		0.43	0.50	0.10	1.9	4.4	30	15	4.8	5.0		●					
R/L 105.0510-15	1.0	M6	0.54	0.55	0.12	1.9	4.4	30	15	4.8	5.0		●					
R/L 105.0510-20	1.0	M6	0.54	0.55	0.12	1.9	4.4	35	20	4.8	5.0		●					
R/L 105.0510-25	1.0	M6	0.54	0.55	0.12	1.9	4.4	40	25	4.8	5.0		●					
R/L 105.0510-30	1.0	M6	0.54	0.55	0.12	1.9	4.4	45	30	4.8	5.0		●					
↳ ...																		

Weitere HM Sorten können Sie in der Sortenübersicht im Kapitel "Technische Hinweise" und der Preisliste finden.

Bestellbeispiel:
für rechte Ausführung und Sorte
R102.0205-10/AL41F

weitere Informationen:

- siehe Technische Hinweise

more informations:

- look at the technical instructions

More carbide grades you can find in the grades summary in the chapter "technical instructions" and in the price list.

order-example:
righthand version and grade
R102.0205-10/AL41F

ULTRAMINI

Bohrungsbearbeitung
ab \varnothing 0.2 mm

grooving, boring and profiling
starting at \varnothing 0.2 mm

Typ Gewindedrehen

metrisches ISO-Gewinde,
Vollprofil, innen

type threading,
metric ISO-thread,
full profile, internal

D min. 2.4 - 7.0 mm
Steigung P = 0.5 - 1.5

D min. 2.4 - 7.0 mm
pitch P = 0.5 - 1.5

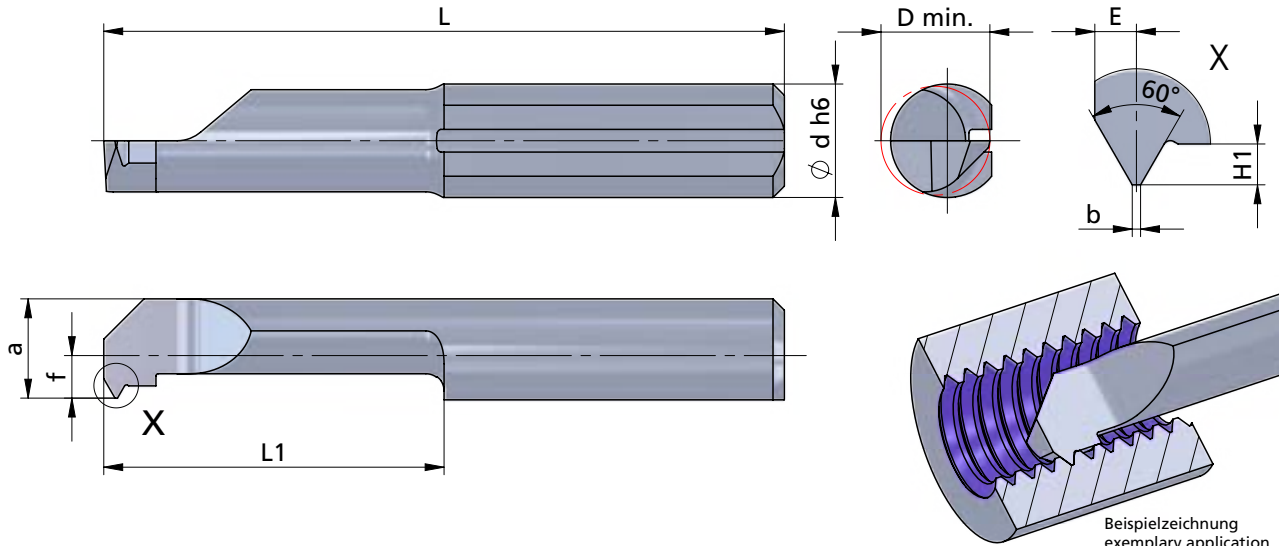
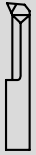

Rechts (R): wie gezeichnet
Links (L): spiegelbildlich

righthand (R): as shown
lefthand version (L): mirror image

Abmessungen in mm

dimensions in mm

Bestellnummer part number	Steigung P pitch P	Regelgewinde / standard thread	H1	E	b	f	a	L	L1	D min.	Ø d h6	Klemmhalter Typ				Klemmhalter Typ toolholder type
												K10F	CN45F	AL41F	PD2F	
⋮ ↙ ↘																
R/L 106.0510-15	1.0		0.54	0.55	0.12	2.3	5.3	30	15	6.0	6.0					
R/L 106.0612-15	1.25	M8	0.67	0.65	0.15	2.3	5.3	30	15	6.0	6.0					
R/L 106.0612-20	1.25	M8	0.67	0.65	0.15	2.3	5.3	35	20	6.0	6.0					660... ...6
R/L 106.0612-30	1.25	M8	0.67	0.65	0.15	2.3	5.3	45	30	6.0	6.0					
R/L 106.0815-15	1.5	M10	0.81	0.75	0.18	2.3	5.3	30	15	6.0	6.0					
R/L 107.0815-15	1.5	M10	0.81	0.75	0.18	2.8	6.3	30	15	7.0	7.0					670... 687... ...7

Weitere HM Sorten können Sie in der Sortenübersicht im Kapitel "Technische Hinweise" und der Preisliste finden.

weitere Informationen:

- siehe Technische Hinweise

More carbide grades you can find in the grades summary in the chapter "technical instructions" and in the price list.

more informations:

- look at the technical instructions

order-example:
righthand version and grade
R106.0510-15/AL41F

Bestellbeispiel:
für rechte Ausführung und Sorte
R106.0510-15/AL41F

ULTRAMINI

Bohrungsbearbeitung
ab \varnothing 0.2 mm

grooving, boring and profiling
starting at \varnothing 0.2 mm

Typ Gewindedrehen

metrisches ISO-Gewinde,
Vollprofil, innen
mit innerer Kühlmittelzufuhr

type threading,
metric ISO-thread,
full profile, internal
with through coolant

Performanceline

D min. 4.0 - 7.0 mm
Steigung P = 0.5 - 1.5

D min. 4.0 - 7.0 mm
pitch P = 0.5 - 1.5

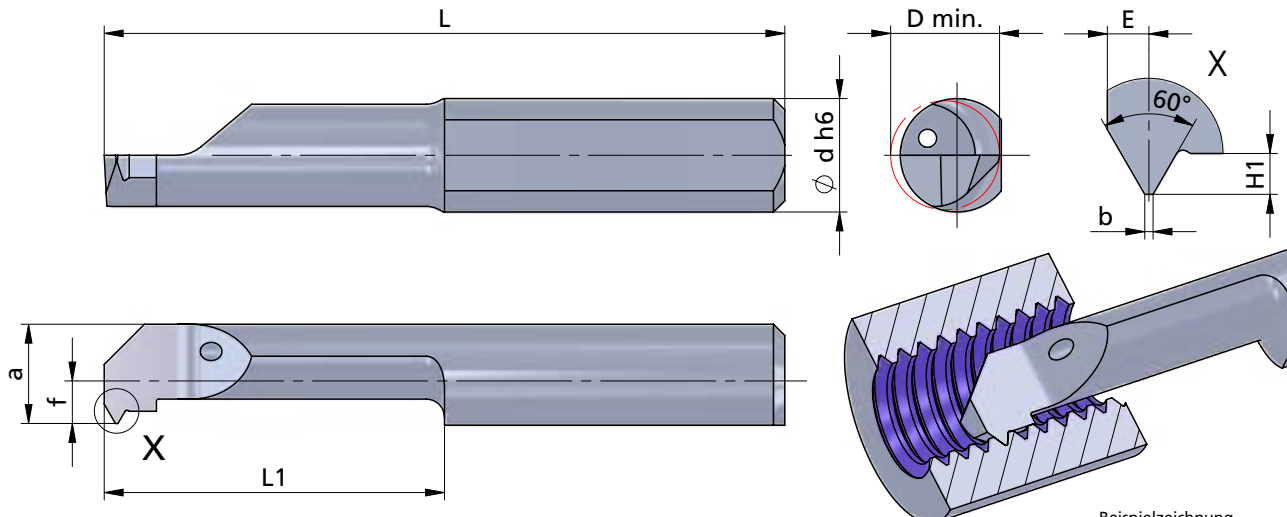

Beispielzeichnung
exemplary application

Rechts (R): wie gezeichnet
Links (L): spiegelbildlich

righthand (R): as shown
lefthand version (L): mirror image



Abmessungen in mm

dimensions in mm

Bestellnummer part number	Steigung P pitch P	Regelgewinde / standard thread	H1	E	b	f	a	L	L1	D min.	\varnothing d h6	Klemmhalter Typ				Klemmhalter Typ	toolholder type
												K10F	P04C	AL41F	PD2F		
R/L 1P4.0205-15	0.5		0.27	0.35	0.06	1.5	3.5	30	15	4.0	4.0	●					640... ...4
R/L 1P4.0408-15	0.8	M5	0.43	0.5	0.10	1.5	3.5	30	15	4.0	4.0	●					640... ...4
R/L 1P5.0205-15	0.5		0.27	0.35	0.06	1.9	4.4	30	15	5.0	5.0	●			645...		640... ...4
R/L 1P5.0407-15	0.75		0.40	0.45	0.09	1.9	4.4	30	15	5.0	5.0	●			645...		640... ...4
R/L 1P5.0408-15	0.8		0.43	0.50	0.10	1.9	4.4	30	15	4.8	5.0	●			645...		650... ...5
R/L 1P5.0510-15	1.0	M6	0.54	0.55	0.12	1.9	4.4	30	15	4.8	5.0	●			645...		650... ...5
R/L 1P6.0510-15	1.0		0.54	0.55	0.12	2.3	5.3	30	15	6.0	6.0	●			676...		660... ...6
R/L 1P6.0612-15	1.25	M8	0.67	0.65	0.15	2.3	5.3	30	15	6.0	6.0	●			676...		660... ...6
R/L 1P6.0815-15	1.5	M10	0.81	0.75	0.18	2.3	5.3	30	15	6.0	6.0	●			676...		660... ...6
R/L 1P7.0815-15	1.5	M10	0.81	0.75	0.18	2.8	6.3	30	15	7.0	7.0	●			676...		670... 687... ...7

Weitere HM Sorten können Sie in der Sortenübersicht im Kapitel "Technische Hinweise" und der Preisliste finden.

weitere Informationen:
• siehe Technische Hinweise

More carbide grades you can find in the grades summary in the chapter "technical instructions" and in the price list.

Bestellbeispiel:
für rechte Ausführung und Sorte
R1P4.0205-15/P04C

more informations:
• look at the technical instructions

order-example:
righthand version and grade
R1P4.0205-15/P04C

ULTRAMINI

Bohrungsbearbeitung
ab \varnothing 0.2 mm

grooving, boring and profiling
starting at \varnothing 0.2 mm

Typ Gewindedrehen

UN-Gewinde,
Teilprofil, innen

D min. 4.0 / 5.0 / 6.0 mm

UN-thread,
partial profile, internal

D min. 4.0 / 5.0 / 6.0 mm

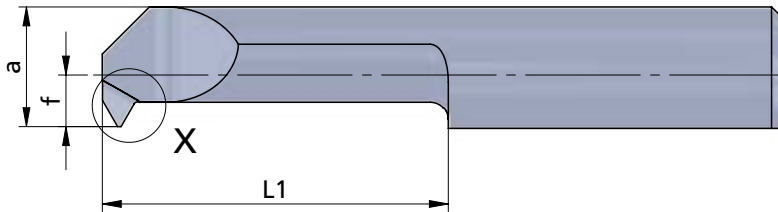
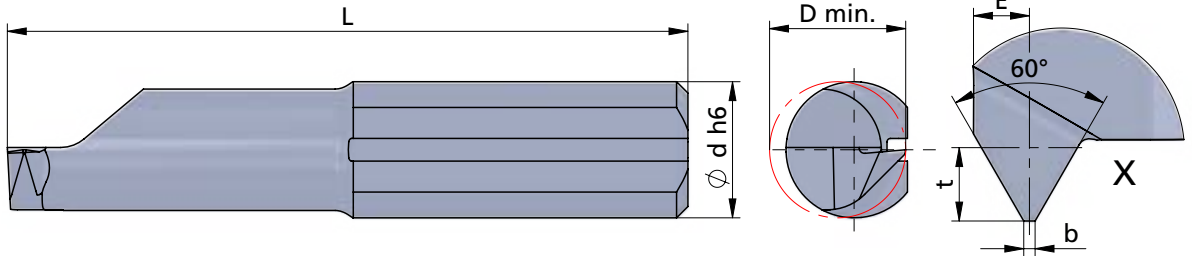

Beispielzeichnung
exemplary application

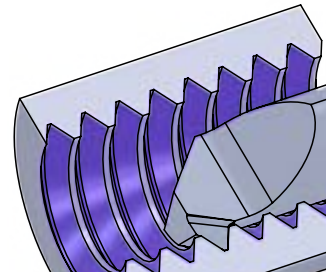

Rechts (R): wie gezeichnet
Links (L): spiegelbildlich

righthand (R): as shown
lefthand version (L): mirror image

Abmessungen in mm

dimensions in mm

Bestellnummer part number	Steigung P pitch P	Gang / Zoll threads / inch	t	E	b	f	a	L	L1	D min.	\varnothing d h6	Klemmhalter Typ toolholder type		
												K10F	CN45F	AL41F
R/L 004.3240-15	0.635 - 0.794	32 - 40	0.50	0.45	0.08	1.5	3.5	30	15	4.0	4.0		●	645... 640... ...4
R/L 005.1620-15	1.270 - 1.588	16 - 20	0.97	0.75	0.16	1.9	4.4	30	15	5.0	5.0		●	645... 650... ...5
R/L 005.2428-15	0.907 - 1.058	24 - 28	0.65	0.55	0.11	1.9	4.4	30	15	5.0	5.0		●	
R/L 005.3240-15	0.635 - 0.794	32 - 40	0.50	0.45	0.08	1.9	4.4	30	15	5.0	5.0		●	660... 676... ...6
R/L 006.1620-15	1.270 - 1.588	16 - 20	0.97	0.75	0.16	2.3	5.3	30	15	6.0	6.0		●	
R/L 006.2428-15	0.907 - 1.058	24 - 28	0.65	0.55	0.11	2.3	5.3	30	15	6.0	6.0		●	

Weitere HM Sorten können Sie in der Sortenübersicht im Kapitel "Technische Hinweise" und der Preisliste finden.

weitere Informationen:

- siehe Technische Hinweise

More carbide grades you can find in the grades summary in the chapter "technical instructions" and in the price list.

more informations:

- look at the technical instructions

order-example:
righthand version and grade
R004.3240-15/AL41F

Bestellbeispiel:
für rechte Ausführung und Sorte
R004.3240-15/AL41F

ULTRAMINI

Bohrungsbearbeitung
ab $\varnothing 0.2 \text{ mm}$

grooving, boring and profiling
starting at $\varnothing 0.2 \text{ mm}$

Typ Gewindedrehen

Whitworth-Gewinde,
Teilprofil, innen

D min. 4.8 - 7.0 mm

type threading,
Whitworth thread,
partial profile, internal

D min. 4.8 - 7.0 mm

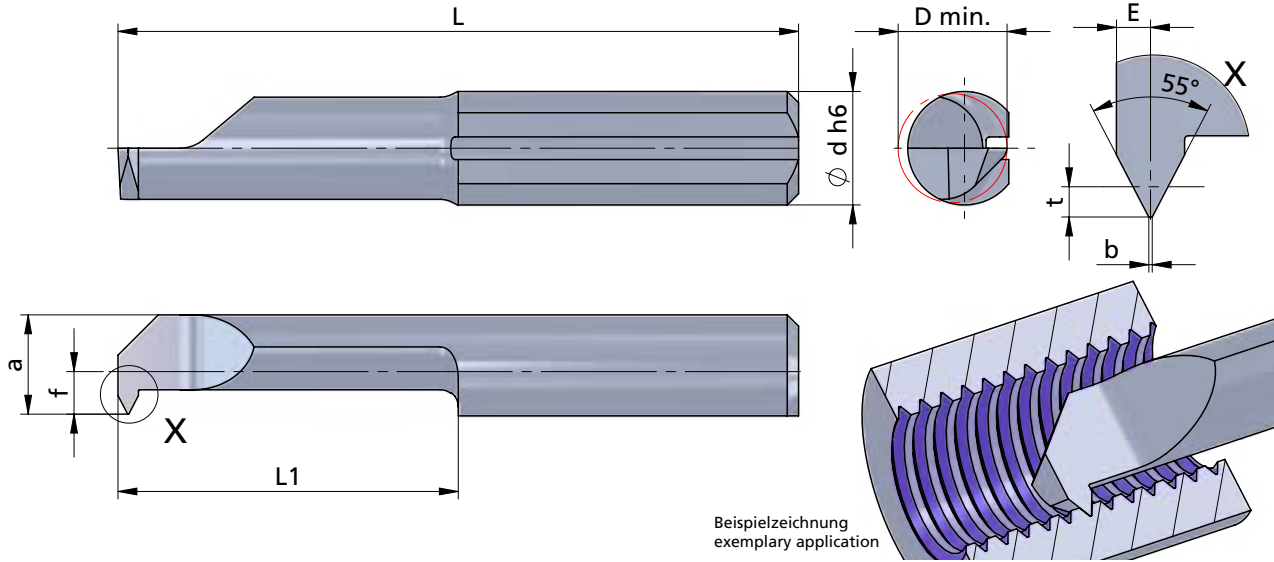

Rechts (R): wie gezeichnet
Links (L): spiegelbildlich

righthand (R): as shown
lefthand version (L): mirror image

Abmessungen in mm

dimensions in mm

Bestellnummer part number	Steigung P pitch P	Gang / Zoll threads / inch								D min.	$\varnothing d h6$	K10F	CN45F	AL41F	Klemmhalter Typ toolholder type
			t	E	b	f	a	L	L1						
R/L 005.5548-15	0.529 - 1.058	48 - 24	0.40	0.45	0.06	1.9	4.4	30	15	4.8	5.0	●	●	645... 650... ...5	
R/L 006.5548-15	0.529 - 1.058	48 - 24	0.40	0.45	0.06	2.3	5.3	30	15	6.0	6.0	●	●	676... 670... 687... ...7	
R/L 006.5524-15	1.058 - 1.588	24 - 16	0.81	0.75	0.12	2.3	5.3	30	15	6.0	6.0	●	●		660... ...6
R/L 007.5524-15	1.058 - 1.588	24 - 16	0.81	0.75	0.12	2.8	6.3	30	15	7.0	7.0	●	●		

Weitere HM Sorten können Sie in der Sortenübersicht im Kapitel "Technische Hinweise" und der Preisliste finden.

Bestellbeispiel:
für rechte Ausführung und Sorte
R005.5548-15/AL41F

weitere Informationen:

- siehe Technische Hinweise

more informations:

- look at the technical instructions

More carbide grades you can find in the grades summary in the chapter "technical instructions" and in the price list.

order-example:
righthand version and grade
R005.5548-15/AL41F

ULTRAMINI

Bohrungsbearbeitung
ab \varnothing 0.2 mm

grooving, boring and profiling
starting at \varnothing 0.2 mm

Typ Gewindedrehen

Whitworth-Gewinde,
Teilprofil, innen
mit innerer Kühlmittelzufuhr

type threading,
Whitworth thread,
partial profile, internal
with through coolant

Performanceline

D min. 4.8 - 7.0 mm

D min. 4.8 - 7.0 mm

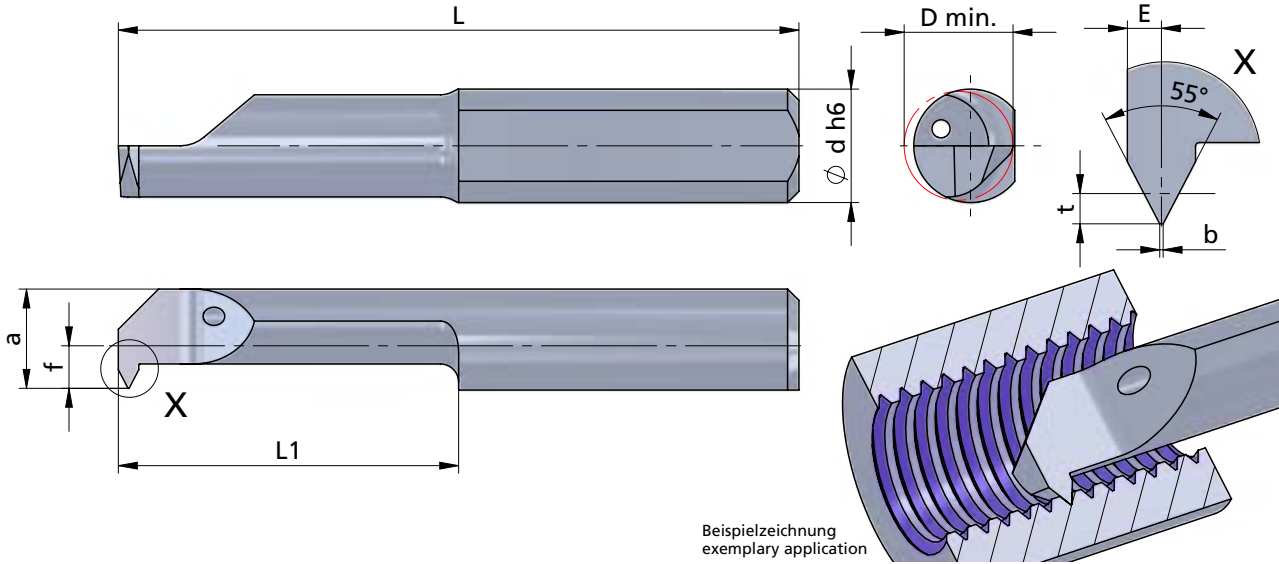

Rechts (R): wie gezeichnet
Links (L): spiegelbildlich

righthand (R): as shown
lefthand version (L): mirror image

Abmessungen in mm

dimensions in mm

Bestellnummer part number	Gang / Zoll threads / inch	t	E	b	f	a	L	L1	D min.	\varnothing d h6	Klemmhalter Typ				Klemmhalter Typ toolholder type
											K10F	P04C	AL41F	PD2F	
R/L P05.5548-15	48 - 24	0.40	0.45	0.06	1.9	4.4	30	15	4.8	5.0	●				645... 650... ...5
R/L P06.5548-15	48 - 24	0.40	0.45	0.06	2.3	5.3	30	15	6.0	6.0	●				
R/L P06.5524-15	24 - 16	0.81	0.75	0.12	2.3	5.3	30	15	6.0	6.0	●				
R/L P07.5524-15	24 - 16	0.81	0.75	0.12	2.8	6.3	30	15	7.0	7.0	●				676... 670... 687... ...7

Weitere HM Sorten können Sie in der Sortenübersicht im Kapitel "Technische Hinweise" und der Preisliste finden.

weitere Informationen:
• siehe Technische Hinweise

More carbide grades you can find in the grades summary in the chapter "technical instructions" and in the price list.

Bestellbeispiel:
für rechte Ausführung und Sorte
RP05.5548-15/P04C

more informations:
• look at the technical instructions

order-example:
righthand version and grade
RP05.5548-15/P04C

ULTRAMINI

Bohrungsbearbeitung
ab $\varnothing 0.2 \text{ mm}$

grooving, boring and profiling
starting at $\varnothing 0.2 \text{ mm}$

Typ Gewindedrehen

Whitworth-Gewinde,
Vollprofil, innen

D min. 6.0 mm

type threading,
Whitworth thread,
full profile, internal

D min. 6.0 mm

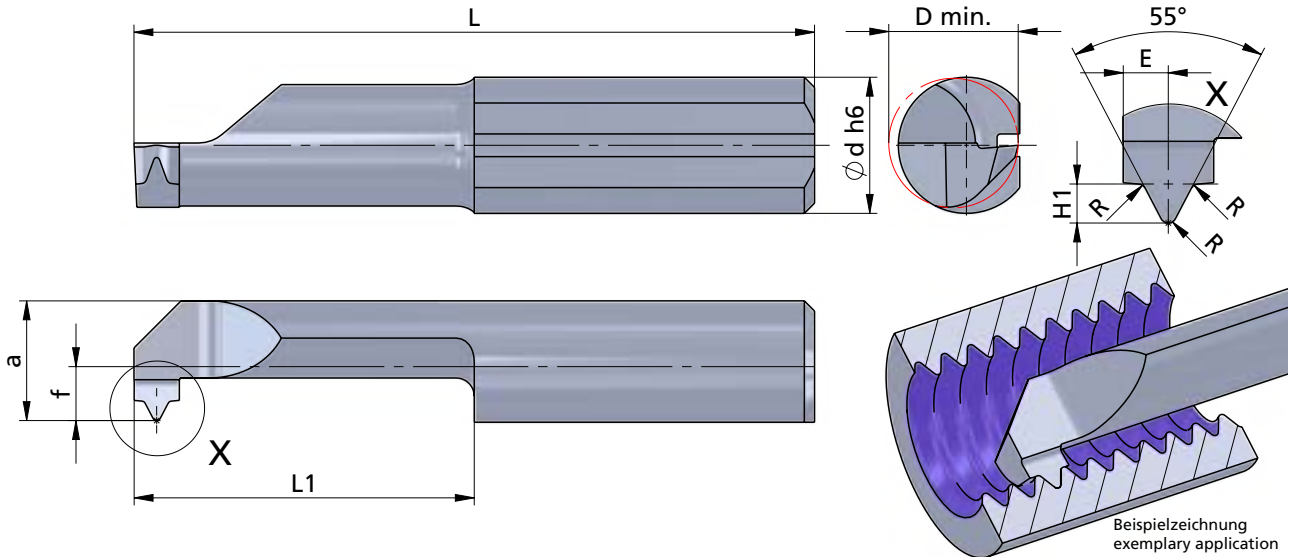

Rechts (R): wie gezeichnet
Links (L): spiegelbildlich

righthand (R): as shown
lefthand version (L): mirror image

Abmessungen in mm

dimensions in mm

Bestellnummer part number	Steigung P pitch P	Gang / Zoll threads / inch	H1	R	E	f	a	L	L1	D min.	$\varnothing d h6$	Klemmhalter Typ toolholder type			
												K10F	CN45F	AL41F	PD2F
R/L 106.5519-15	1.336	19	0.86	0.18	1	2.3	5.3	30	15	6.0	6.0	●			
R/L 106.5522-15	1.154	22	0.74	0.16	1	2.3	5.3	30	15	6.0	6.0	●			660, ... 676,6
R/L 106.5528-15	0.907	28	0.58	0.12	0.8	2.3	5.3	30	15	6.0	6.0	●			

Weitere HM Sorten können Sie in der Sortenübersicht im Kapitel "Technische Hinweise" und der Preisliste finden.

Bestellbeispiel:
für rechte Ausführung und Sorte
R106.5519-15/AL41F

weitere Informationen:

- siehe Technische Hinweise

more informations:

- look at the technical instructions

More carbide grades you can find in the grades summary in the chapter "technical instructions" and in the price list.

order-example:
righthand version and grade
R106.5519-15/AL41F

ULTRAMINI

Bohrungsbearbeitung
ab $\varnothing 0.2 \text{ mm}$

grooving, boring and profiling
starting at $\varnothing 0.2 \text{ mm}$

Typ Gewindedrehen

Whitworth-Gewinde,
Vollprofil, innen
mit innerer Kühlmittelzufuhr

type threading,
Whitworth thread,
full profile, internal
with through coolant

Performanceline

D min. 6.0 mm

D min. 6.0 mm

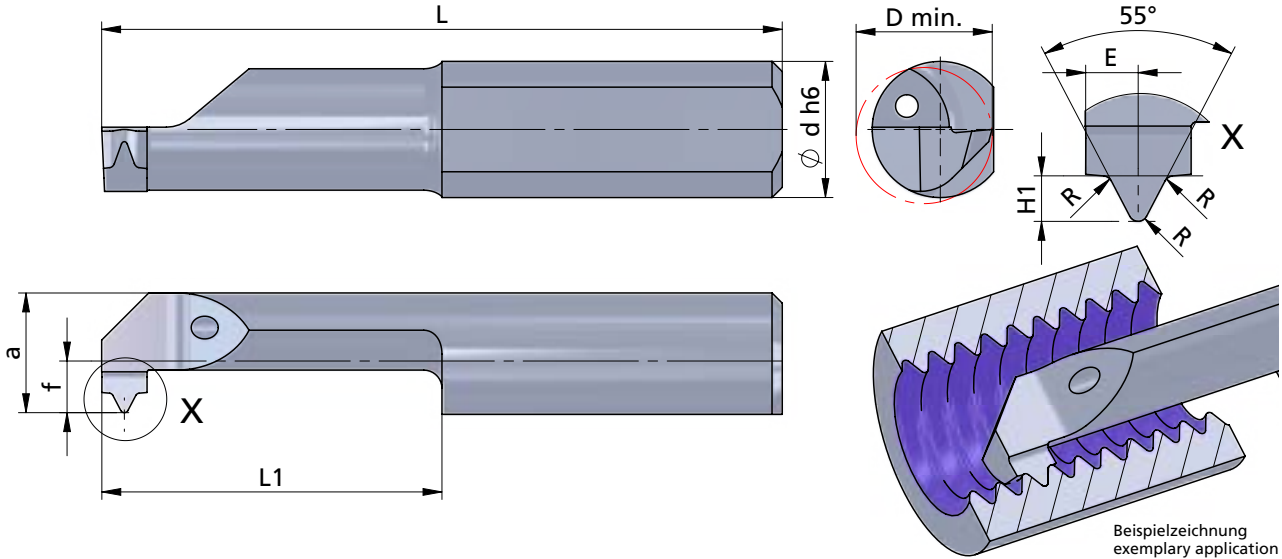

Beispielzeichnung
exemplary application

Rechts (R): wie gezeichnet
Links (L): spiegelbildlich

righthand (R): as shown
lefthand version (L): mirror image

Abmessungen in mm

dimensions in mm



Bestellnummer part number	Steigung P pitch P	Gang / Zoll threads / inch	H1	R	E	f	a	L	L1	D min.	$\varnothing d h6$	Klemmhalter Typ				Klemmhalter Typ toolholder type
												K10F	P04C	AL41F	PD2F	
R/L 1P6.5519-15	1.336	19	0.86	0.18	1	2.3	5.3	30	15	6.0	6.0	●				
R/L 1P6.5522-15	1.154	22	0.74	0.16	1	2.3	5.3	30	15	6.0	6.0	●				660, ... 676,6
R/L 1P6.5528-15	0.907	28	0.58	0.12	0.8	2.3	5.3	30	15	6.0	6.0	●				

Weitere HM Sorten können Sie in der Sortenübersicht im Kapitel "Technische Hinweise" und der Preisliste finden.

weitere Informationen:

- siehe Technische Hinweise

More carbide grades you can find in the grades summary in the chapter "technical instructions" and in the price list.

more informations:

- look at the technical instructions

order-example:
righthand version and grade
R1P6.5519-15/P04C

Bestellbeispiel:
für rechte Ausführung und Sorte
R1P6.5519-15/P04C

ULTRAMINI

Bohrungsbearbeitung
ab \varnothing 0.2 mm

grooving, boring and profiling
starting at \varnothing 0.2 mm

Typ Gewindedrehen

NPT-Gewinde,
Teilprofil, innen

D min. 6.0 mm

type threading,
NPT thread,
partial profile, internal

D min. 6.0 mm

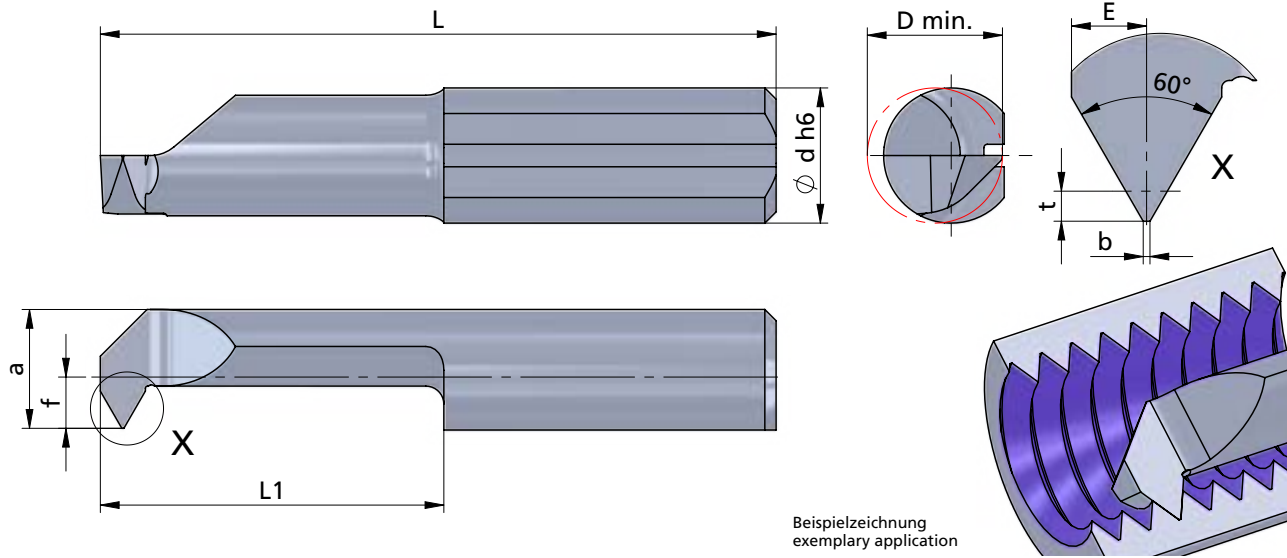

Rechts (R): wie gezeichnet
Links (L): spiegelbildlich

righthand (R): as shown
lefthand version (L): mirror image

Abmessungen in mm

dimensions in mm

Bestellnummer part number	Steigung P pitch P	Gang / Zoll threads / inch	t	E	b	f	a	L	L1	D min.	\varnothing d h6	Klemmhalter Typ toolholder type				
												K10F	CN45F	AL41F	PD2F	
R/L 006.NP18-15	1.411	18	1.35	1	0.09	2.3	5.3	30	15	6.0	6.0	●				
R/L 006.NP18-22	1.411	18	1.35	1	0.09	2.3	5.3	37	22	6.0	6.0		●			
R/L 006.NP27-15	0.940	27	1	0.8	0.06	2.3	5.3	30	15	6.0	6.0		●			660... 676... ...6
R/L 006.NP27-22	0.940	27	1	0.8	0.06	2.3	5.3	37	22	6.0	6.0		●			

Weitere HM Sorten können Sie in der Sortenübersicht im Kapitel "Technische Hinweise" und der Preisliste finden.

Bestellbeispiel:
für rechte Ausführung und Sorte
R006.NP18-15/AL41F

weitere Informationen:

- siehe Technische Hinweise

more informations:

- look at the technical instructions

More carbide grades you can find in the grades summary in the chapter "technical instructions" and in the price list.

order-example:
righthand version and grade
R006.NP18-15/AL41F

ULTRAMINI

Bohrungsbearbeitung
ab Ø 0.2 mm

grooving, boring and profiling
starting at Ø 0.2 mm

Typ Gewindedrehen

NPT-Gewinde,
Teilprofil, innen
mit innerer Kühlmittelzufuhr

type threading,
NPT thread,
partial profile, internal
with through coolant

Performanceline

D min. 6.0 mm

D min. 6.0 mm

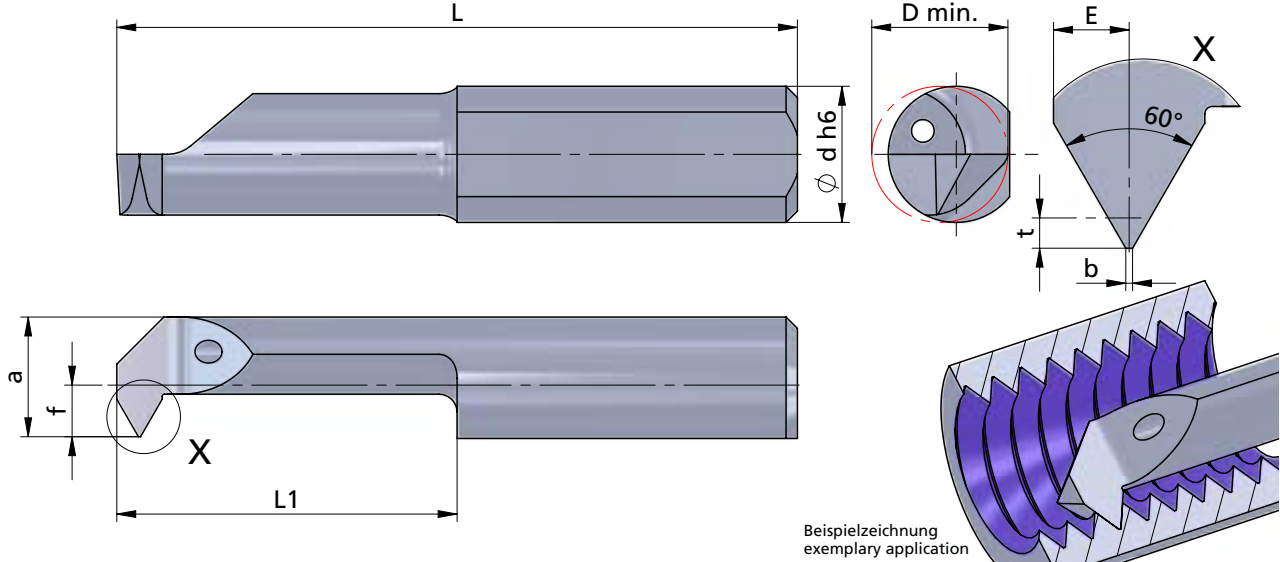

Rechts (R): wie gezeichnet
Links (L): spiegelbildlich

righthand (R): as shown
lefthand version (L): mirror image

Abmessungen in mm

dimensions in mm



Bestellnummer part number	Steigung P pitch P	Gang / Zoll threads / inch								D min.	Ø d h6	Klemmhalter Typ toolholder type				
			t	E	b	f	a	L	L1			K10F	P04C	AL41F	PD2F	
R/L P06.NP18-15	1.411	18	1.35	1	0.09	2.3	5.3	30	15	6.0	6.0	●				
R/L P06.NP18-22	1.411	18	1.35	1	0.09	2.3	5.3	37	22	6.0	6.0	●				
R/L P06.NP27-15	0.940	27	1	0.8	0.06	2.3	5.3	30	15	6.0	6.0	●				660... 676... ...6
R/L P06.NP27-22	0.940	27	1	0.8	0.06	2.3	5.3	37	22	6.0	6.0	●				

Weitere HM Sorten können Sie in der Sortenübersicht im Kapitel "Technische Hinweise" und der Preisliste finden.

weitere Informationen:
• siehe Technische Hinweise

More carbide grades you can find in the grades summary in the chapter "technical instructions" and in the price list.

Bestellbeispiel:
für rechte Ausführung und Sorte
RP06.NP18-15/P04C

more informations:
• look at the technical instructions

order-example:
righthand version and grade
RP06.NP18-15/P04C

ULTRAMINI

Bohrungsbearbeitung
ab \varnothing 0.2 mm

grooving, boring and profiling
starting at \varnothing 0.2 mm

Typ Gewindedrehen

Trapezgewinde,
Teilprofil, innen

type threading,
trapezoidal thread,
partial profile, internal

D min. 7.0 mm
Steigung P = 2.0 - 3.0

D min. 7.0 mm
pitch P = 2.0 - 3.0

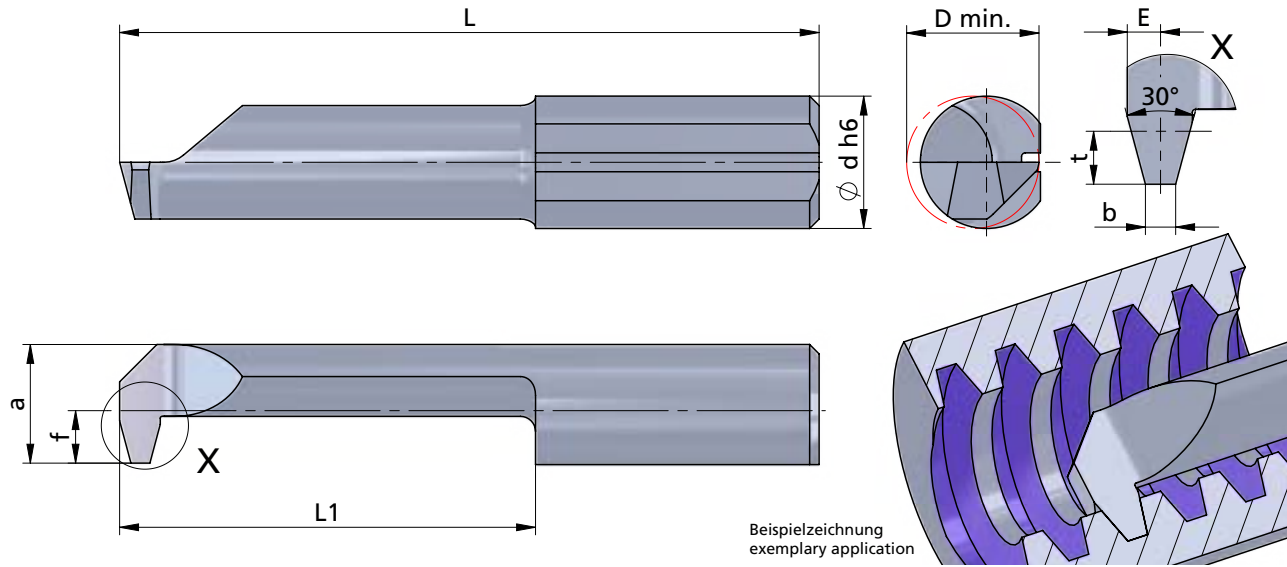

Rechts (R): wie gezeichnet
Links (L): spiegelbildlich

righthand (R): as shown
lefthand version (L): mirror image

Abmessungen in mm

dimensions in mm

Bestellnummer part number	Steigung P pitch P	t	E	b	f	a	L	L1	D min.	\varnothing d h6	Klemmhalter Typ toolholder type				
											K10F	CN45F	AL41F	PD2F	
R/L 007.1220-22	2	1.25	0.75	0.6	2.8	6.3	37	22	7.0	7.0		●			
R/L 007.1220-30	2	1.25	0.75	0.6	2.8	6.3	45	30	7.0	7.0		●			670, ... 676, ... 687,7
R/L 007.1730-22	3	1.75	1.10	1.0	2.8	6.3	37	22	7.0	7.0		●			
R/L 007.1730-30	3	1.75	1.10	1.0	2.8	6.3	45	30	7.0	7.0		●			

Weitere HM Sorten können Sie in der Sortenübersicht im Kapitel "Technische Hinweise" und der Preisliste finden.

Bestellbeispiel:
für rechte Ausführung und Sorte
R007.1220-22/AL41F

weitere Informationen:

- siehe Technische Hinweise

more informations:

- look at the technical instructions

More carbide grades you can find in the grades summary in the chapter "technical instructions" and in the price list.

order-example:
righthand version and grade
R007.1220-22/AL41F

ULTRAMINI

Bohrungsbearbeitung
ab \varnothing 0.2 mm

grooving, boring and profiling
starting at \varnothing 0.2 mm

Typ Gewindedrehen

Trapezgewinde,
Teilprofil, innen
mit innerer Kühlmittelzufuhr

type threading,
trapezoidal thread,
partial profile, internal
with through coolant

Performanceline

D min. 7.0 mm
Steigung P = 2.0 - 3.0

D min. 7.0 mm
pitch P = 2.0 - 3.0

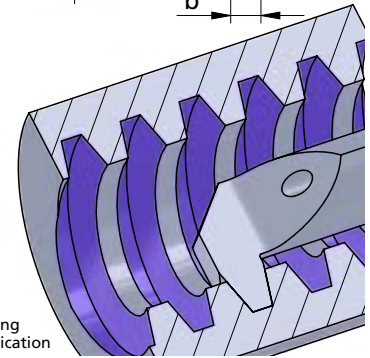
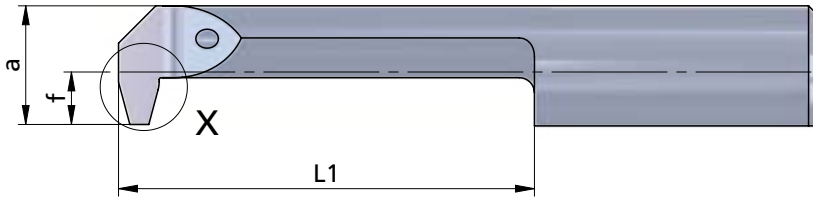
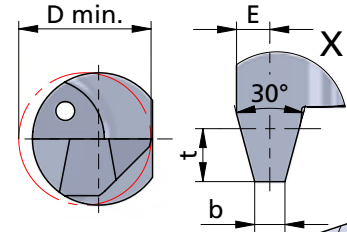
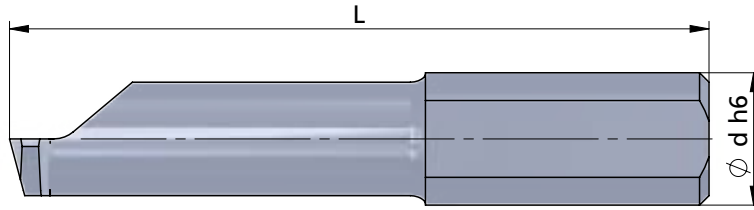

Beispielzeichnung
exemplary application

Rechts (R): wie gezeichnet
Links (L): spiegelbildlich

righthand (R): as shown
lefthand version (L): mirror image



Abmessungen in mm

dimensions in mm

Bestellnummer part number	Steigung P pitch P	t	E	b	f	a	L	L1	D min.	Ø d h6					Klemhalter Typ toolholder type
											K10F	P04C	AL41F	PD2F	
R/L P07.1220-22	2	1.25	0.75	0.6	2.8	6.3	37	22	7.0	7.0	●				
R/L P07.1220-30	2	1.25	0.75	0.6	2.8	6.3	45	30	7.0	7.0	●				670, ... 676, ... 687,7
R/L P07.1730-22	3	1.75	1.10	1.0	2.8	6.3	37	22	7.0	7.0	●				
R/L P07.1730-30	3	1.75	1.10	1.0	2.8	6.3	45	30	7.0	7.0	●				

Weitere HM Sorten können Sie in der Sortenübersicht im Kapitel "Technische Hinweise" und der Preisliste finden.

weitere Informationen:

- siehe Technische Hinweise

More carbide grades you can find in the grades summary in the chapter "technical instructions" and in the price list.

more informations:

- look at the technical instructions

order-example:
righthand version and grade
RP07.1220-22/P04C

Bestellbeispiel:
für rechte Ausführung und Sorte
RP07.1220-22/P04C

ULTRAMINI

Bohrungsbearbeitung
ab \varnothing 0.2 mm

grooving, boring and profiling
starting at \varnothing 0.2 mm

Impressionen

impressions



ULTRAMINI

Bohrungsbearbeitung
ab $\varnothing 0.2$ mm

grooving, boring and profiling
starting at $\varnothing 0.2$ mm

Typ 510M

Axialstechen
mit Eckenradius

face grooving
with corner radius

D min. 5.0 mm
Stechtiefe t max. 4.0 mm
Nutbreite bis 2.0 mm

D min. 5.0 mm
depth of groove t max. 4.0 mm
width of groove up to 2.0 mm

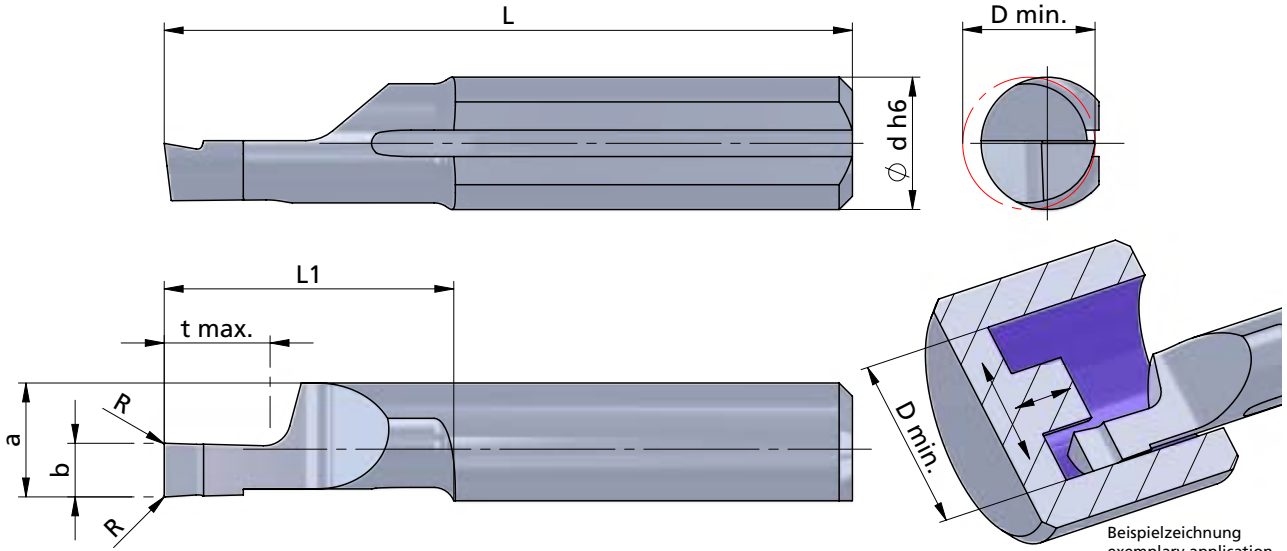

Rechts (R): wie gezeichnet
Links (L): spiegelbildlich

righthand (R): as shown
lefthand version (L): mirror image

Abmessungen in mm

dimensions in mm

Bestellnummer part number	b +0.05	a	L	L1	t max.	D min.	\varnothing d h6	R	Klemmhalter Typ toolholder type				
									K10F	CN45F	AL41F	P07C	
R/L 510M0508-10	0.5	4.3	26	11	1.0	5.0	5.0	0.05			●		645 ... 6505
R/L 510M0808-10	0.8	4.3	26	11	2.0	5.0	5.0	0.05			●		
R/L 510M1008-10	1.0	4.3	26	11	2.0	5.0	5.0	0.05			●		
R/L 510M1508-10	1.5	4.3	26	11	3.0	5.0	5.0	0.05			●		
R/L 510M2008-10	2.0	4.3	26	11	4.0	5.0	5.0	0.05			●		
R/L 510M1008-20	1.0	4.3	35	20	2.0	5.0	5.0	0.05			●		
R/L 510M1508-20	1.5	4.3	35	20	3.0	5.0	5.0	0.05			●		
R/L 510M2008-20	2.0	4.3	35	20	4.0	5.0	5.0	0.05			●		

Weitere HM Sorten können Sie in der Sortenübersicht im Kapitel "Technische Hinweise" und der Preisliste finden.

More carbide grades you can find in the grades summary in the chapter "technical instructions" and in the price list.

Bestellbeispiel:
für rechte Ausführung und Sorte
R510M0508-10/AL41F

order-example:
righthand version and grade
R510M0508-10/AL41F

ULTRAMINI

Bohrungsbearbeitung
ab $\varnothing 0.2 \text{ mm}$

grooving, boring and profiling
starting at $\varnothing 0.2 \text{ mm}$

Typ 51PM

Axialstechen
mit Eckenradius
und innerer Kühlmittelzufuhr

face grooving
with corner radius
and through coolant

Performanceline

D min. 5.0 mm
Stechtiefe t max. 4.0 mm
Nutbreite bis 2.0 mm

D min. 5.0 mm
depth of groove t max. 4.0 mm
width of groove up to 2.0 mm

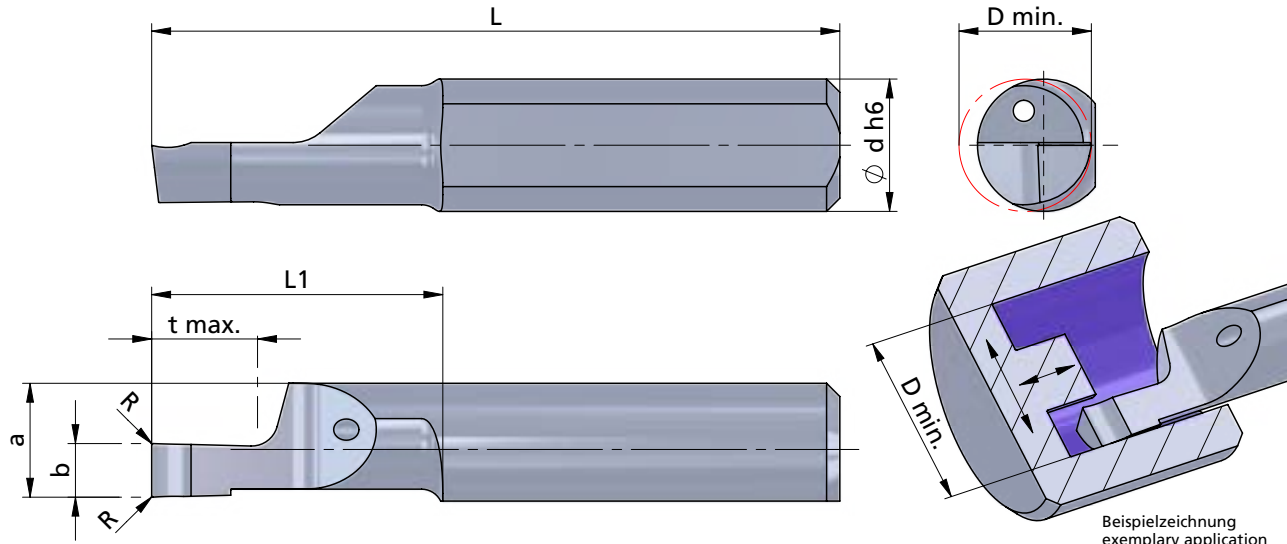

Beispielzeichnung
exemplary application

Rechts (R): wie gezeichnet
Links (L): spiegelbildlich

righthand (R): as shown
lefthand version (L): mirror image



Abmessungen in mm

dimensions in mm

Bestellnummer part number	b +0.05	a	L	L1	t max.	D min.	Ø d h6	R	K10F P04C AL41F P07C	Klemmhalter Typ	toolholder type
											645... 650... ...5
R/L 51PM1008-10	1.0	4.3	26	11	2.0	5.0	5.0	0.05	●		
R/L 51PM1508-10	1.5	4.3	26	11	3.0	5.0	5.0	0.05	●		
R/L 51PM2008-10	2.0	4.3	26	11	4.0	5.0	5.0	0.05	●		
R/L 51PM1008-20	1.0	4.3	35	20	2.0	5.0	5.0	0.05	●		
R/L 51PM1508-20	1.5	4.3	35	20	3.0	5.0	5.0	0.05	●		
R/L 51PM2008-20	2.0	4.3	35	20	4.0	5.0	5.0	0.05	●		

Weitere HM Sorten können Sie in der Sortenübersicht im Kapitel "Technische Hinweise" und der Preisliste finden.

Bestellbeispiel:
für rechte Ausführung und Sorte
R51PM1008-10/P04C

More carbide grades you can find in the grades summary in the chapter "technical instructions" and in the price list.

order-example:
righthand version and grade
R51PM1008-10/P04C

ULTRAMINI

Bohrungsbearbeitung
ab \varnothing 0.2 mm

grooving, boring and profiling
starting at \varnothing 0.2 mm

Typ 610

Axialstechen

face grooving

D min. 6.0 mm
Stechtiefe t max. 3.5 mm
Nutbreite bis 3.0 mm

D min. 6.0 mm
depth of groove tmax. 3.5 mm
width of groove up to 3.0 mm

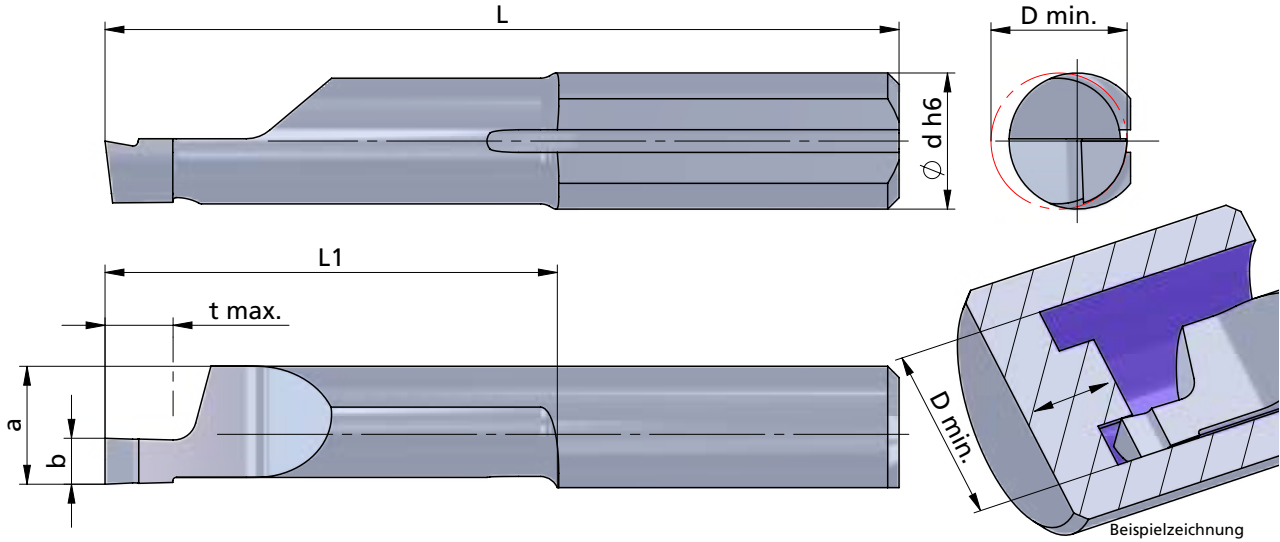

Rechts (R): wie gezeichnet
Links (L): spiegelbildlich

righthand (R): as shown
lefthand version (L): mirror image

Abmessungen in mm

dimensions in mm

Bestellnummer part number	b +0.05	a	L	L1	t max.	D min.	Ø d h6					Klemmhalter Typ toolholder type
								K10F	CN45F	AL41F	P07C	
R/L 610.1008-10	1.0	5.2	26	11	1.5	6.0	6.0	●	●	●		660... 676... ...6
R/L 610.1508-10	1.5	5.2	26	11	2.5	6.0	6.0		●	●		
R/L 610.2008-10	2.0	5.2	26	11	3.0	6.0	6.0	●	●	●		
R/L 610.2508-10	2.5	5.2	26	11	3.5	6.0	6.0		●	●		
R/L 610.3008-10	3.0	5.2	26	11	3.5	6.0	6.0	●	●	●		
R/L 610.1008-20	1.0	5.2	35	20	1.5	6.0	6.0	●	●	●		
R/L 610.1508-20	1.5	5.2	35	20	2.5	6.0	6.0		●	●		
R/L 610.2008-20	2.0	5.2	35	20	3.0	6.0	6.0	●	●	●		
R/L 610.2508-20	2.5	5.2	35	20	3.5	6.0	6.0		●	●		
R/L 610.3008-20	3.0	5.2	35	20	3.5	6.0	6.0	●	●	●		
R/L 610.1008-30	1.0	5.2	45	30	1.5	6.0	6.0		●	●		
R/L 610.1508-30	1.5	5.2	45	30	2.5	6.0	6.0		●	●		
R/L 610.2008-30	2.0	5.2	45	30	3.0	6.0	6.0	●	●	●		
R/L 610.2508-30	2.5	5.2	45	30	3.5	6.0	6.0		●	●		
R/L 610.3008-30	3.0	5.2	45	30	3.5	6.0	6.0	●	●	●		

Weitere HM Sorten können Sie in der Sortenübersicht im Kapitel "Technische Hinweise" und der Preisliste finden.

More carbide grades you can find in the grades summary in the chapter "technical instructions" and in the price list.

Bestellbeispiel:
für rechte Ausführung und Sorte
R610.1008-10/AL41F

order-example:
righthand version and grade
R610.1008-10/AL41F

ULTRAMINI

Bohrungsbearbeitung
ab \varnothing 0.2 mm

grooving, boring and profiling
starting at \varnothing 0.2 mm

Typ 610M

Axialstechen
mit Eckenradius

face grooving
with corner radius

D min. 6.0 mm
Stechtiefe t max. 6.0 mm
Nutbreite bis 3.0 mm

D min. 6.0 mm
depth of groove t max. 6.0 mm
width of groove up to 3.0 mm

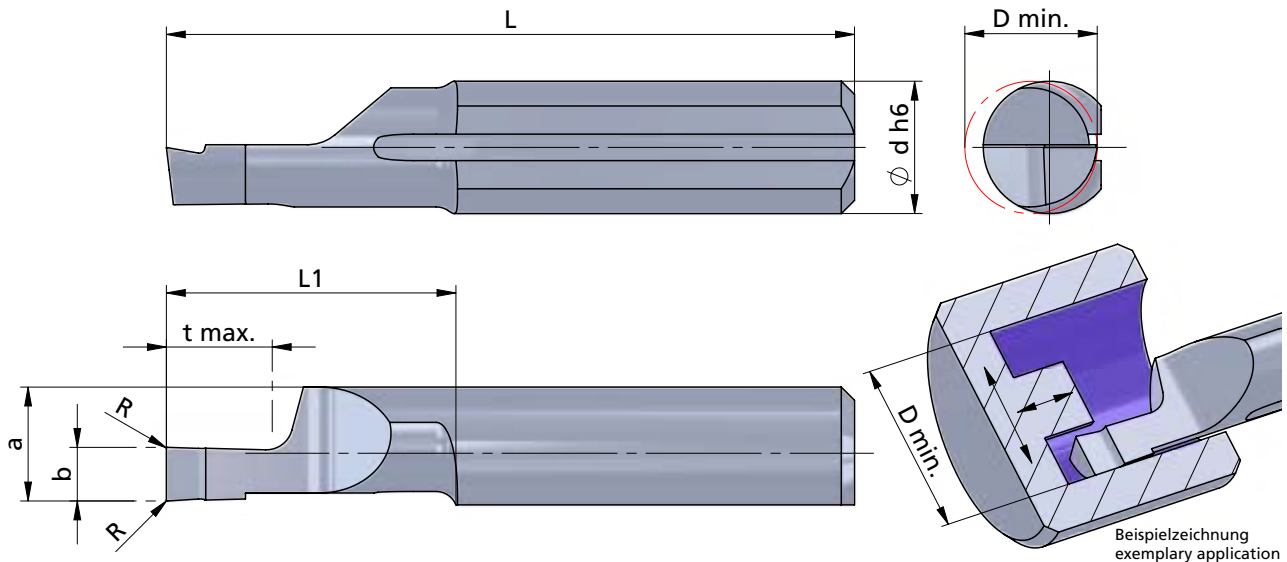

Rechts (R): wie gezeichnet
Links (L): spiegelbildlich

righthand (R): as shown
lefthand version (L): mirror image

Abmessungen in mm

dimensions in mm

Bestellnummer part number	b +0.05	a	L	L1	t max.	D min.	\varnothing d h6	R	Klemmhalter Typ				Klemmhalter Typ toolholder type
									K10F	CN45F	AL41F	P07C	
R/L 610M1008-10	1.0	5.2	26	11	2.0	6.0	6.0	0.1			●		660... 676... ...6
R/L 610M1508-10	1.5	5.2	26	11	3.0	6.0	6.0	0.1			●		
R/L 610M2008-10	2.0	5.2	26	11	4.0	6.0	6.0	0.1			●		
R/L 610M2508-10	2.5	5.2	26	11	5.0	6.0	6.0	0.1			●		
R/L 610M3008-10	3.0	5.2	26	11	6.0	6.0	6.0	0.1			●		
R/L 610M1008-20	1.0	5.2	35	20	2.0	6.0	6.0	0.1			●		
R/L 610M1508-20	1.5	5.2	35	20	3.0	6.0	6.0	0.1			●		
R/L 610M2008-20	2.0	5.2	35	20	4.0	6.0	6.0	0.1			●		
R/L 610M2508-20	2.5	5.2	35	20	5.0	6.0	6.0	0.1			●		
R/L 610M3008-20	3.0	5.2	35	20	6.0	6.0	6.0	0.1			●		
R/L 610M1008-30	1.0	5.2	45	30	2.0	6.0	6.0	0.1			●		
R/L 610M1508-30	1.5	5.2	45	30	3.0	6.0	6.0	0.1			●		
R/L 610M2008-30	2.0	5.2	45	30	4.0	6.0	6.0	0.1			●		
R/L 610M2508-30	2.5	5.2	45	30	5.0	6.0	6.0	0.1			●		
R/L 610M3008-30	3.0	5.2	45	30	6.0	6.0	6.0	0.1			●		

Weitere HM Sorten können Sie in der Sortenübersicht im Kapitel "Technische Hinweise" und der Preisliste finden.

Bestellbeispiel:
für rechte Ausführung und Sorte
R610M1008-10/AL41F

More carbide grades you can find in the grades summary in the chapter "technical instructions" and in the price list.

order-example:
righthand version and grade
R610M1008-10/AL41F

ULTRAMINI

Bohrungsbearbeitung
ab \varnothing 0.2 mm

grooving, boring and profiling
starting at \varnothing 0.2 mm

Typ 61PM

Axialstechen
mit Eckenradius
und innerer Kühlmittelzufuhr

face grooving
with corner radius
and through coolant

Performanceline

D min. 6.0 mm
Stechtiefe t max. 6.0 mm
Nutbreite bis 3.0 mm

D min. 6.0 mm
depth of groove t max. 6.0 mm
width of groove up to 3.0 mm

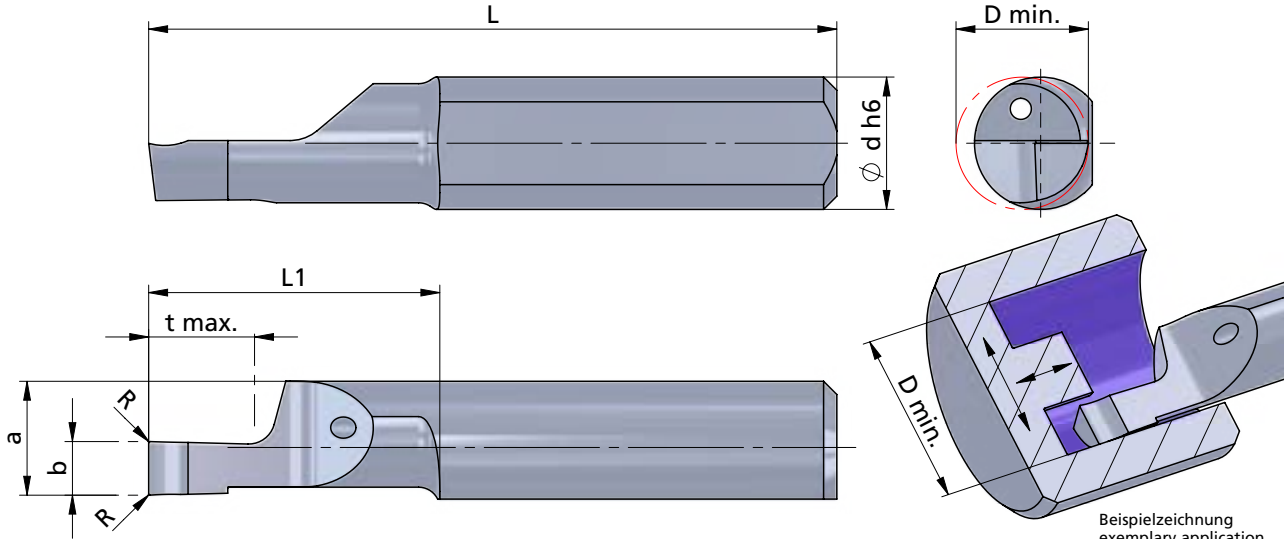

Beispielzeichnung
exemplary application

Rechts (R): wie gezeichnet
Links (L): spiegelbildlich

righthand (R): as shown
lefthand version (L): mirror image

Abmessungen in mm

dimensions in mm



Bestellnummer part number	b +0.05	a	L	L1	t max.	D min.	\varnothing d h6	R	K10F	P04C	AL41F	P07C	Klemmhalter Typ	toolholder type
														660... 676... ...6
R/L 61PM1008-10	1.0	5.2	26	11	2.0	6.0	6.0	0.1	●	●				
R/L 61PM1508-10	1.5	5.2	26	11	3.0	6.0	6.0	0.1	●	●				
R/L 61PM2008-10	2.0	5.2	26	11	4.0	6.0	6.0	0.1	●	●				
R/L 61PM2508-10	2.5	5.2	26	11	5.0	6.0	6.0	0.1	●	●				
R/L 61PM3008-10	3.0	5.2	26	11	6.0	6.0	6.0	0.1	●	●				
R/L 61PM1008-20	1.0	5.2	35	20	2.0	6.0	6.0	0.1	●	●				
R/L 61PM1508-20	1.5	5.2	35	20	3.0	6.0	6.0	0.1	●	●				
R/L 61PM2008-20	2.0	5.2	35	20	4.0	6.0	6.0	0.1	●	●				
R/L 61PM2508-20	2.5	5.2	35	20	5.0	6.0	6.0	0.1	●	●				
R/L 61PM3008-20	3.0	5.2	35	20	6.0	6.0	6.0	0.1	●	●				
R/L 61PM1008-30	1.0	5.2	45	30	2.0	6.0	6.0	0.1	●	●				
R/L 61PM1508-30	1.5	5.2	45	30	3.0	6.0	6.0	0.1	●	●				
R/L 61PM2008-30	2.0	5.2	45	30	4.0	6.0	6.0	0.1	●	●				
R/L 61PM2508-30	2.5	5.2	45	30	5.0	6.0	6.0	0.1	●	●				
R/L 61PM3008-30	3.0	5.2	45	30	6.0	6.0	6.0	0.1	●	●				

Weitere HM Sorten können Sie in der Sortenübersicht im Kapitel "Technische Hinweise" und der Preisliste finden.

More carbide grades you can find in the grades summary in the chapter "technical instructions" and in the price list.

Bestellbeispiel:
für rechte Ausführung und Sorte
R61PM1008-10/P04C

order-example:
righthand version and grade
R61PM1008-10/P04C

ULTRAMINI

Bohrungsbearbeitung
ab $\varnothing 0.2$ mm

grooving, boring and profiling
starting at $\varnothing 0.2$ mm

Typ 610

Axialstechen
mit Vollradius

face grooving
with full radius

D min. 6.0 mm
Stechtiefe t max. 6.0 mm
Nutbreite bis 3.0 mm

D min. 6.0 mm
depth of groove t max. 6.0 mm
width of groove up to 3.0 mm

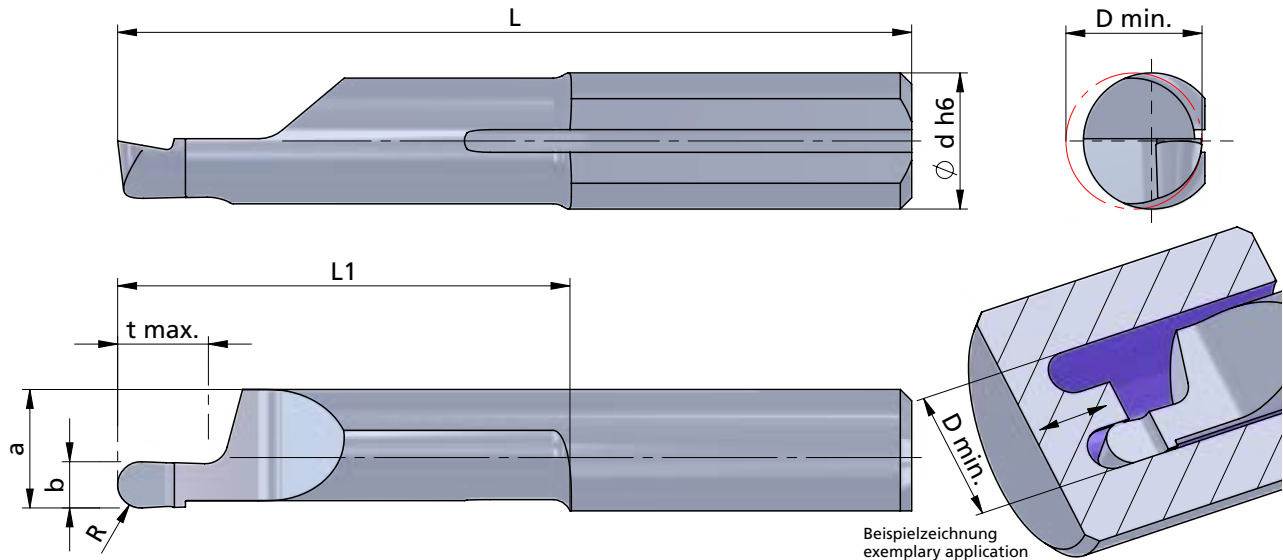

Beispielzeichnung
exemplary application

Rechts (R): wie gezeichnet
Links (L): spiegelbildlich

righthand (R): as shown
lefthand version (L): mirror image

Abmessungen in mm

dimensions in mm

Bestellnummer part number	b +0.05	R	a	L	L1	t max.	D min.	Ø d h6					Klemmhalter Typ toolholder type
									K10F	CN45F	AL41F	P07C	
R/L 610.1005-10	1.0	0.50	5.2	26	11	2.0	6.0	6.0	●	●			660... 676... ...6
R/L 610.1608-10	1.6	0.80	5.2	26	11	3.0	6.0	6.0		●			
R/L 610.2010-10	2.0	1.00	5.2	26	11	4.0	6.0	6.0			●		
R/L 610.2512-10	2.5	1.25	5.2	26	11	5.0	6.0	6.0	●		●		
R/L 610.3015-10	3.0	1.50	5.2	26	11	6.0	6.0	6.0	●		●		
R/L 610.1005-20	1.0	0.50	5.2	35	20	2.0	6.0	6.0	●	●			
R/L 610.1608-20	1.6	0.80	5.2	35	20	3.0	6.0	6.0		●			
R/L 610.2010-20	2.0	1.00	5.2	35	20	4.0	6.0	6.0	●		●		
R/L 610.2512-20	2.5	1.25	5.2	35	20	5.0	6.0	6.0			●		
R/L 610.3015-20	3.0	1.50	5.2	35	20	6.0	6.0	6.0	●		●		

Weitere HM Sorten können Sie in der Sortenübersicht im Kapitel "Technische Hinweise" und der Preisliste finden.

Bestellbeispiel:
für rechte Ausführung und Sorte
R610.1005-10/AL41F

More carbide grades you can find in the grades summary in the chapter "technical instructions" and in the price list.

order-example:
righthand version and grade
R610.1005-10/AL41F

ULTRAMINI

Bohrungsbearbeitung
ab \varnothing 0.2 mm

grooving, boring and profiling
starting at \varnothing 0.2 mm

Typ 61P

Axialstechen
mit Vollradius
und innerer Kühlmittelzufuhr

face grooving
with full radius
and through coolant

Performanceline

D min. 6.0 mm
Stechtiefe t max. 6.0 mm
Nutbreite bis 3.0 mm

D min. 6.0 mm
depth of groove t max. 6.0 mm
width of groove up to 3.0 mm

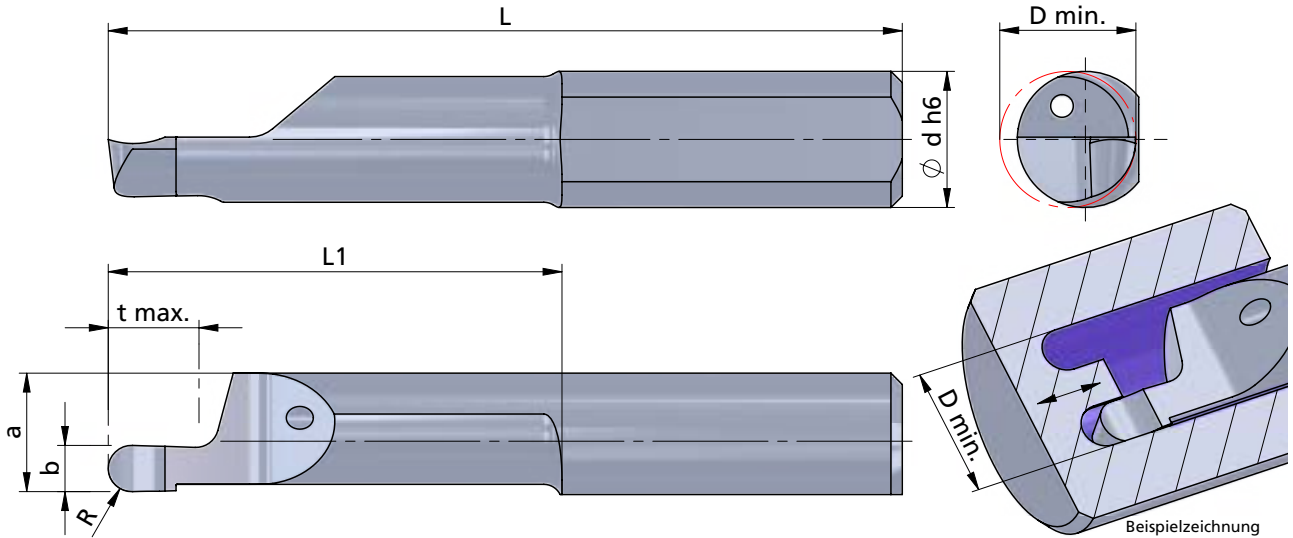

Beispielzeichnung
exemplary application

Rechts (R): wie gezeichnet
Links (L): spiegelbildlich

righthand (R): as shown
lefthand version (L): mirror image

Abmessungen in mm

dimensions in mm



Bestellnummer part number	b +0.05	R	a	L	L1	t max.	D min.	Ø d h6	K10F P04C AL41F P07C	Klemmhalter Typ	toolholder type
R/L 61P.1005-10	1.0	0.50	5.2	26	11	2.0	6.0	6.0	●	660... 676... ...6	
R/L 61P.1608-10	1.6	0.80	5.2	26	11	3.0	6.0	6.0	●		
R/L 61P.2010-10	2.0	1.00	5.2	26	11	4.0	6.0	6.0	●		
R/L 61P.2512-10	2.5	1.25	5.2	26	11	5.0	6.0	6.0	●		
R/L 61P.3015-10	3.0	1.50	5.2	26	11	6.0	6.0	6.0	●		
R/L 61P.1005-20	1.0	0.50	5.2	35	20	2.0	6.0	6.0	●		
R/L 61P.1608-20	1.6	0.80	5.2	35	20	3.0	6.0	6.0	●		
R/L 61P.2010-20	2.0	1.00	5.2	35	20	4.0	6.0	6.0	●		
R/L 61P.2512-20	2.5	1.25	5.2	35	20	5.0	6.0	6.0	●		
R/L 61P.3015-20	3.0	1.50	5.2	35	20	6.0	6.0	6.0	●		

Weitere HM Sorten können Sie in der Sortenübersicht im Kapitel "Technische Hinweise" und der Preisliste finden.

More carbide grades you can find in the grades summary in the chapter "technical instructions" and in the price list.

Bestellbeispiel:
für rechte Ausführung und Sorte
R61P.1005-10/P04C

order-example:
righthand version and grade
R61P.1005-10/P04C

ULTRAMINI

Bohrungsbearbeitung
ab $\varnothing 0.2$ mm

grooving, boring and profiling
starting at $\varnothing 0.2$ mm

Typ 620

Axialstechen
am Zapfen vorbei

face grooving
in pivots

D min. 6.0 mm
Stechtiefe t max. 6.0 mm
Nutbreite bis 3.0 mm

D min. 6.0 mm
depth of groove t max. 6.0 mm
width of groove up to 3.0 mm

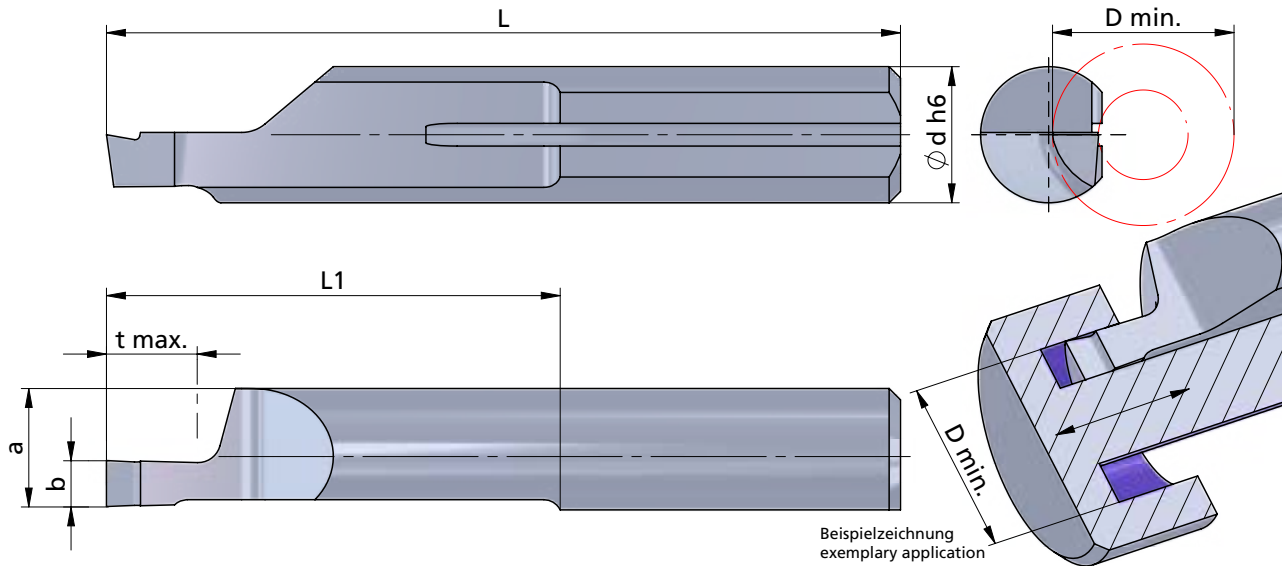

Beispielzeichnung
exemplary application

Rechts (R): wie gezeichnet
Links (L): spiegelbildlich

righthand (R): as shown
lefthand version (L): mirror image

Abmessungen in mm

dimensions in mm

Bestellnummer part number	b +0.05	a	L	L1	t max.	D min.	Ø d h6					Klemmhalter Typ toolholder type
								K10F	CN45F	AL41F	PD2F	
R/L 620.1006-20	1.0	5.2	35	20	2.0	6.0	6.0	●	●	●		660... 676... ...6
R/L 620.1506-20	1.5	5.2	35	20	3.0	6.0	6.0	●	●	●		
R/L 620.2006-20	2.0	5.2	35	20	4.0	6.0	6.0	●	●	●		
R/L 620.2506-20	2.5	5.2	35	20	5.0	6.0	6.0		●	●		
R/L 620.3006-20	3.0	5.2	35	20	6.0	6.0	6.0		●	●		

Weitere HM Sorten können Sie in der Sortenübersicht im Kapitel "Technische Hinweise" und der Preisliste finden.

Bestellbeispiel:
für rechte Ausführung und Sorte
R620.1006-20/AL41F

More carbide grades you can find in the grades summary in the chapter "technical instructions" and in the price list.

order-example:
righthand version and grade
R620.1006-20/AL41F

ULTRAMINI

Bohrungsbearbeitung
ab $\varnothing 0.2$ mm

grooving, boring and profiling
starting at $\varnothing 0.2$ mm

Typ 620M

Axialstechen
am Zapfen vorbei,
mit Eckenradius

face grooving
in pivots,
with corner radius

D min. 6.0 mm
Stechtiefe t max. 6.0 mm
Nutbreite bis 3.0 mm

D min. 6.0 mm
depth of groove t max. 6.0 mm
width of groove up to 3.0 mm

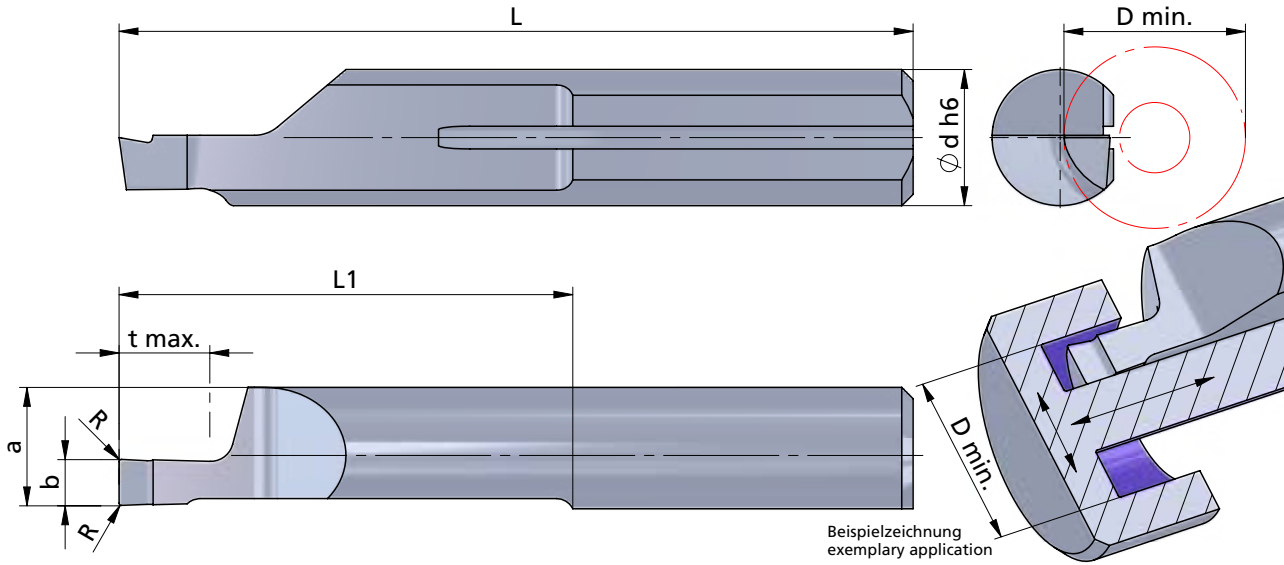

Beispielzeichnung
exemplary application

Rechts (R): wie gezeichnet
Links (L): spiegelbildlich

righthand (R): as shown
lefthand version (L): mirror image

Abmessungen in mm

dimensions in mm

Bestellnummer part number	b +0.05	a	L	L1	t max.	D min.	Ø d h6	R	Klemmhalter Typ				toolholder type
									K10F	CN45F	AL41F	PD2F	
R/L 620M1006-20	1.0	5.2	35	20	2.0	6.0	6.0	0.1					
R/L 620M1506-20	1.5	5.2	35	20	3.0	6.0	6.0	0.1					
R/L 620M2006-20	2.0	5.2	35	20	4.0	6.0	6.0	0.1					
R/L 620M2506-20	2.5	5.2	35	20	5.0	6.0	6.0	0.1					
R/L 620M3006-20	3.0	5.2	35	20	6.0	6.0	6.0	0.1					

Weitere HM Sorten können Sie in der Sortenübersicht im Kapitel "Technische Hinweise" und der Preisliste finden.

More carbide grades you can find in the grades summary in the chapter "technical instructions" and in the price list.

ULTRAMINI

Bohrungsbearbeitung
ab $\varnothing 0.2$ mm

grooving, boring and profiling
starting at $\varnothing 0.2$ mm

Typ 62PM

Axialstechen am Zapfen vorbei,
mit Eckenradius
und innerer Kühlmittelzufuhr

face grooving
in pivots,
with corner radius
and through coolant

Performanceline

D min. 6.0 mm
Stechtiefe t max. 6.0 mm
Nutbreite bis 3.0 mm

D min. 6.0 mm
depth of groove t max. 6.0 mm
width of groove up to 3.0 mm

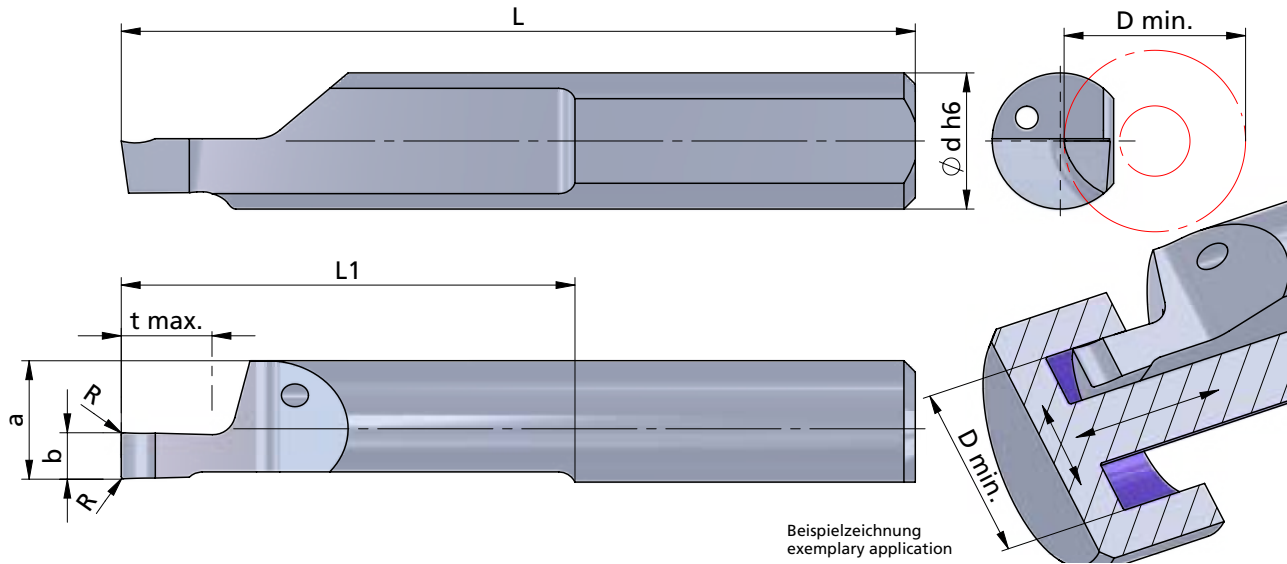

Rechts (R): wie gezeichnet
Links (L): spiegelbildlich

righthand (R): as shown
lefthand version (L): mirror image

Abmessungen in mm

dimensions in mm



Bestellnummer part number	b +0.05	a	L	L1	t max.	D min.	Ø d h6	R	K10F P04C AL41F PD2F	Klemmhalter Typ	toolholder type
											660... 676... ...6
R/L 62PM1006-20	1.0	5.2	35	20	2.0	6.0	6.0	0.1	●		
R/L 62PM1506-20	1.5	5.2	35	20	3.0	6.0	6.0	0.1	●		
R/L 62PM2006-20	2.0	5.2	35	20	4.0	6.0	6.0	0.1	●		
R/L 62PM2506-20	2.5	5.2	35	20	5.0	6.0	6.0	0.1	●		
R/L 62PM3006-20	3.0	5.2	35	20	6.0	6.0	6.0	0.1	●		

Weitere HM Sorten können Sie in der Sortenübersicht im Kapitel "Technische Hinweise" und der Preisliste finden.

Bestellbeispiel:
für rechte Ausführung und Sorte
R62PM1006-20/P04C

More carbide grades you can find in the grades summary in the chapter "technical instructions" and in the price list.

order-example:
righthand version and grade
R62PM1006-20/P04C

ULTRAMINI

Bohrungsbearbeitung
ab $\varnothing 0.2$ mm

grooving, boring and profiling
starting at $\varnothing 0.2$ mm

Typ 620

Axialstechen
am Zapfen vorbei
mit Vollradius

face grooving
in pivots
with full radius

D min. 6.0 mm
Stechtiefe t max. 6.0 mm
Nutbreite bis 3.0 mm

D min. 6.0 mm
depth of groove t max. 6.0 mm
width of groove up to 3.0 mm

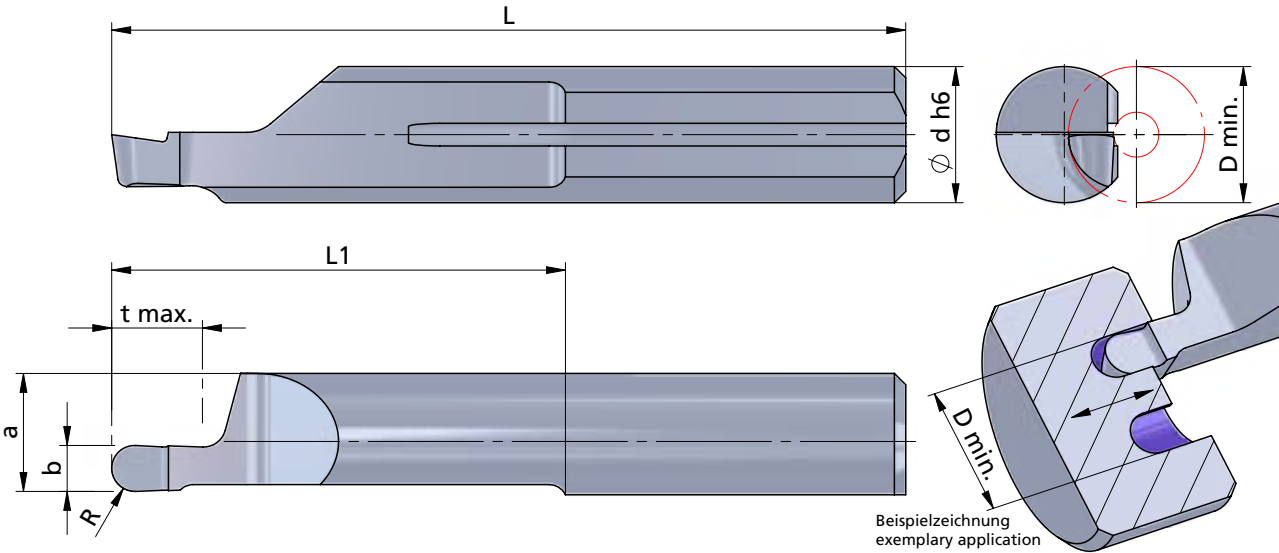
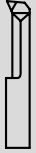

Rechts (R): wie gezeichnet
Links (L): spiegelbildlich

righthand (R): as shown
lefthand version (L): mirror image

Abmessungen in mm

dimensions in mm

Bestellnummer part number	b +0.05	R	a	L	L1	t max.	D min.	\varnothing d h6	K10F CN45F AL41F P07C	Klemmhalter Typ	toolholder type
R/L 620.1005-20	1.0	0.50	5.2	35	20	2.0	6.0	6.0			
R/L 620.1608-20	1.6	0.80	5.2	35	20	3.0	6.0	6.0			
R/L 620.2010-20	2.0	1.00	5.2	35	20	4.0	6.0	6.0			
R/L 620.2512-20	2.5	1.25	5.2	35	20	5.0	6.0	6.0			
R/L 620.3015-20	3.0	1.50	5.2	35	20	6.0	6.0	6.0			

Weitere HM Sorten können Sie in der Sortenübersicht im Kapitel "Technische Hinweise" und der Preisliste finden.

More carbide grades you can find in the grades summary in the chapter "technical instructions" and in the price list.

Bestellbeispiel:
für rechte Ausführung und Sorte
R620.1005-20/AL41F

order-example:
righthand version and grade
R620.1005-20/AL41F

ULTRAMINI

Bohrungsbearbeitung
ab $\varnothing 0.2 \text{ mm}$

grooving, boring and profiling
starting at $\varnothing 0.2 \text{ mm}$

Typ 010

Axialstechen

face grooving

D min. 6.0 mm
Stechtiefe t max. 3.5 mm
Nutbreite bis 3.0 mm

D min. 6.0 mm
depth of groove t max. 3.5 mm
width of groove up to 3.0 mm

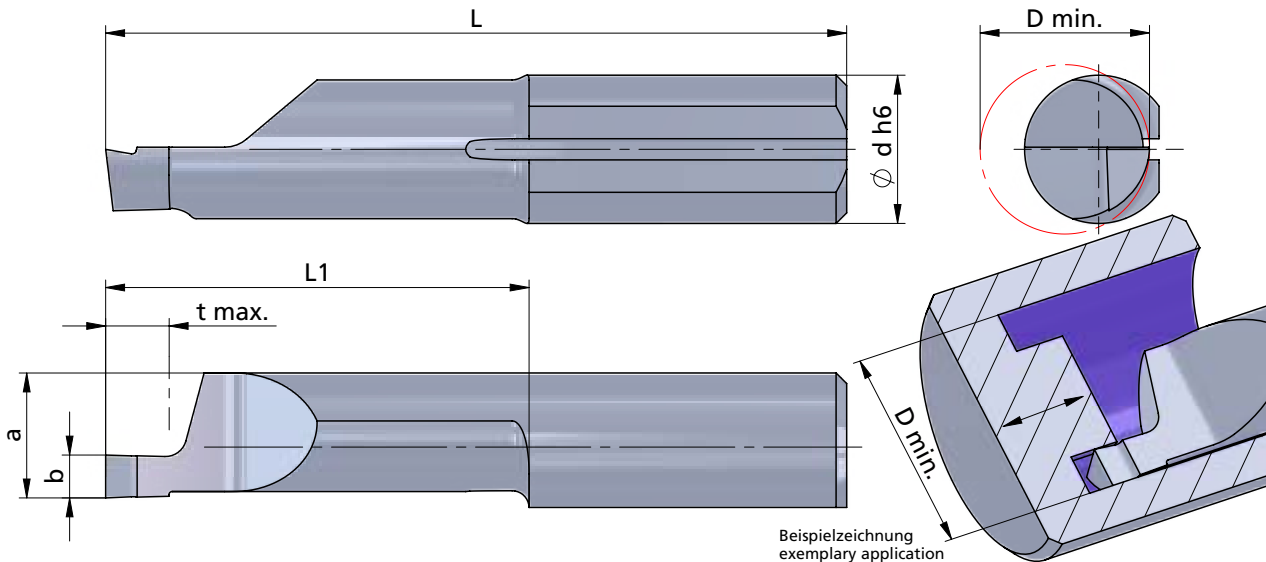

Rechts (R): wie gezeichnet
Links (L): spiegelbildlich

righthand (R): as shown
lefthand version (L): mirror image

Abmessungen in mm

dimensions in mm

Bestellnummer part number	b +0.05	a	L	L1	t max.	D min.	$\varnothing d h6$	Klemmhalter Typ				toolholder type
								K10F	CN45F	AL41F	P07C	
R/L 010.1006-10	1.0	5.2	26	11	1.5	6.0	6.0	●	●			660... ...6
R/L 010.1506-10	1.5	5.2	26	11	2.0	6.0	6.0	●	●			
R/L 010.1008-10	1.0	5.9	26	11	1.5	8.0	7.0	●	●			
R/L 010.1508-10	1.5	5.9	26	11	2.5	8.0	7.0	●	●			
R/L 010.2008-10	2.0	5.9	26	11	3.0	8.0	7.0	●	●			
R/L 010.2508-10	2.5	5.9	26	11	3.5	8.0	7.0	●	●			
R/L 010.3008-10	3.0	5.9	26	11	3.5	8.0	7.0	●	●			
R/L 010.1008-20	1.0	5.9	35	20	1.5	8.0	7.0	●	●			
R/L 010.1508-20	1.5	5.9	35	20	2.5	8.0	7.0	●	●			
R/L 010.2008-20	2.0	5.9	35	20	3.0	8.0	7.0	●	●			
R/L 010.2508-20	2.5	5.9	35	20	3.5	8.0	7.0	●	●			
R/L 010.3008-20	3.0	5.9	35	20	3.5	8.0	7.0	●	●			
↳ ...												

Weitere HM Sorten können Sie in der Sortenübersicht im Kapitel "Technische Hinweise" und der Preisliste finden.

Bestellbeispiel:
für rechte Ausführung und Sorte
R010.1006-10/AL41F

More carbide grades you can find in the grades summary in the chapter "technical instructions" and in the price list.

order-example:
righthand version and grade
R010.1006-10/AL41F

ULTRAMINI

Bohrungsbearbeitung
ab Ø 0.2 mm

grooving, boring and profiling
starting at Ø 0.2 mm

Typ 010

Axialstechen

face grooving

D min. 6.0 mm
Stechtiefe t max. 3.5 mm
Nutbreite bis 3.0 mm

D min. 6.0 mm
depth of groove t max. 3.5 mm
width of groove up to 3.0 mm

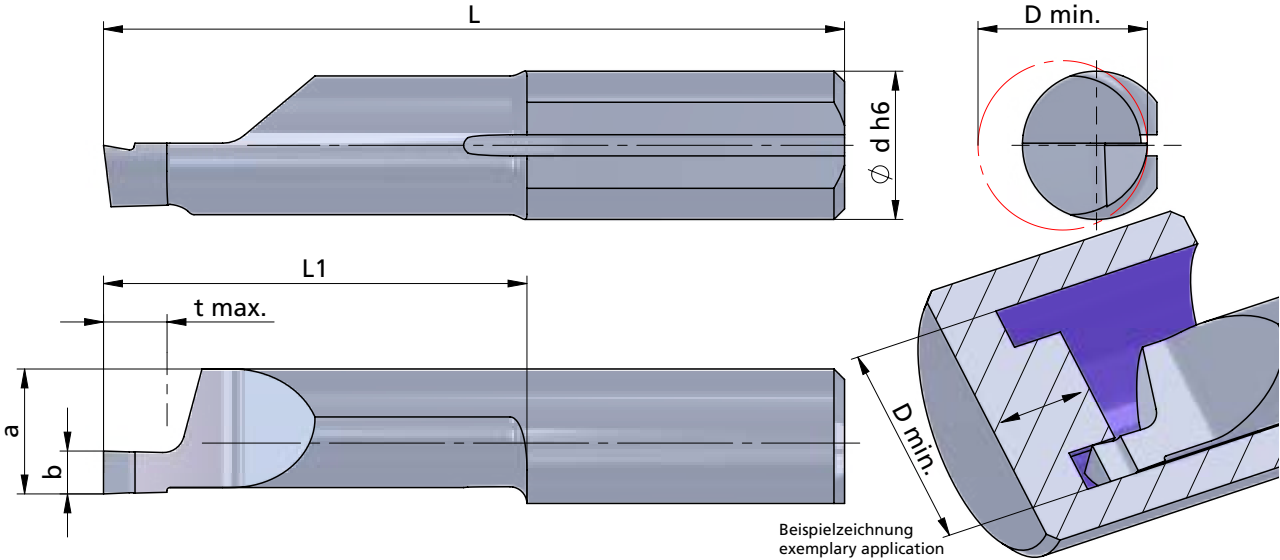

Rechts (R): wie gezeichnet
Links (L): spiegelbildlich

righthand (R): as shown
lefthand version (L): mirror image

Abmessungen in mm

dimensions in mm

Bestellnummer part number	b +0.05	a	L	L1	t max.	D min.	Ø d h6	K10F	CN45F	AL41F	P07C	Klemmhalter Typ	toolholder type
R/L 010.1008-30	1.0	5.9	45	30	1.5	8.0	7.0	●	●				
R/L 010.1508-30	1.5	5.9	45	30	2.5	8.0	7.0	●	●				
R/L 010.2008-30	2.0	5.9	45	30	3.0	8.0	7.0	●	●				
R/L 010.2508-30	2.5	5.9	45	30	3.5	8.0	7.0	●	●				
R/L 010.3008-30	3.0	5.9	45	30	3.5	8.0	7.0	●	●				

670...
676...
687...
...7

Weitere HM Sorten können Sie in der Sortenübersicht im Kapitel "Technische Hinweise" und der Preisliste finden.

More carbide grades you can find in the grades summary in the chapter "technical instructions" and in the price list.

Bestellbeispiel:
für rechte Ausführung und Sorte
R010.1008-30/AL41F

order-example:
righthand version and grade
R010.1008-30/AL41F

ULTRAMINI

Bohrungsbearbeitung
ab \varnothing 0.2 mm

grooving, boring and profiling
starting at \varnothing 0.2 mm

Typ 010M

Axialstechen
mit Eckenradius

face grooving
with corner radius

D min. 8.0 mm
Stechtiefe t max. 6.0 mm
Nutbreite bis 3.0 mm

D min. 8.0 mm
depth of groove t max. 6.0 mm
width of groove up to 3.0 mm

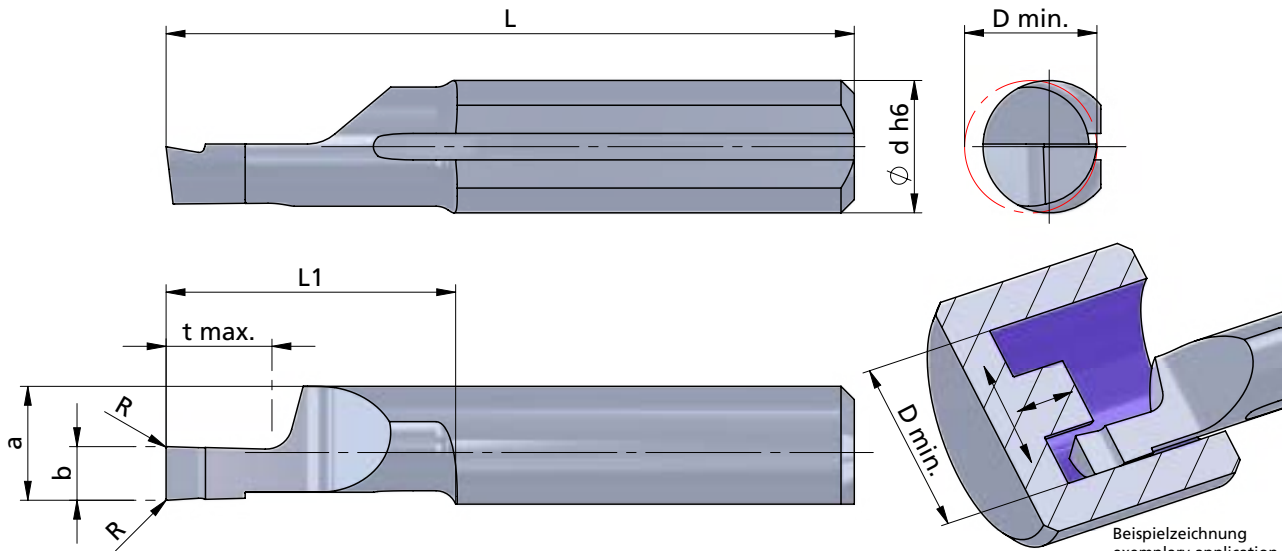

Rechts (R): wie gezeichnet
Links (L): spiegelbildlich

righthand (R): as shown
lefthand version (L): mirror image

Abmessungen in mm

dimensions in mm

Bestellnummer part number	b +0.05	b (inch)	a	L	L1	t max.	D min.	\varnothing d h6	R	Klemmhalter Typ toolholder type				
										K10F	CN45F	AL41F	P07C	
R/L 010M1008-10	1.0		5.9	26	11	2.0	8.0	7.0	0.1					670... 676... 687... ...7
R/L 010M1508-10	1.5		5.9	26	11	3.0	8.0	7.0	0.1					
R/L 010M1578-10	1.57	0.062"	5.9	26	11	3.0	8.0	7.0	0.1					
R/L 010M2008-10	2.0		5.9	26	11	4.0	8.0	7.0	0.1					
R/L 010M2508-10	2.5		5.9	26	11	5.0	8.0	7.0	0.1					
R/L 010M3008-10	3.0		5.9	26	11	6.0	8.0	7.0	0.1					
R/L 010M1008-20	1.0		5.9	35	20	2.0	8.0	7.0	0.1					
R/L 010M1508-20	1.5		5.9	35	20	3.0	8.0	7.0	0.1					
R/L 010M2008-20	2.0		5.9	35	20	4.0	8.0	7.0	0.1					
R/L 010M2308-20	2.38	0.094"	5.9	35	20	5.0	8.0	7.0	0.1					
R/L 010M2508-20	2.5		5.9	35	20	5.0	8.0	7.0	0.1					
R/L 010M3008-20	3.0		5.9	35	20	6.0	8.0	7.0	0.1					
↳ ...														

Weitere HM Sorten können Sie in der Sortenübersicht im Kapitel "Technische Hinweise" und der Preisliste finden.

Bestellbeispiel:
für rechte Ausführung und Sorte
R010M1008-10/AL41F

More carbide grades you can find in the grades summary in the chapter "technical instructions" and in the price list.

order-example:
righthand version and grade
R010M1008-10/AL41F

ULTRAMINI

Bohrungsbearbeitung
ab Ø 0.2 mm

grooving, boring and profiling
starting at Ø 0.2 mm

Typ 010M

Axialstechen
mit Eckenradius

face grooving
with corner radius

D min. 8.0 mm
Stechtiefe t max. 6.0 mm
Nutbreite bis 3.0 mm

D min. 8.0 mm
depth of groove t max. 6.0 mm
width of groove up to 3.0 mm

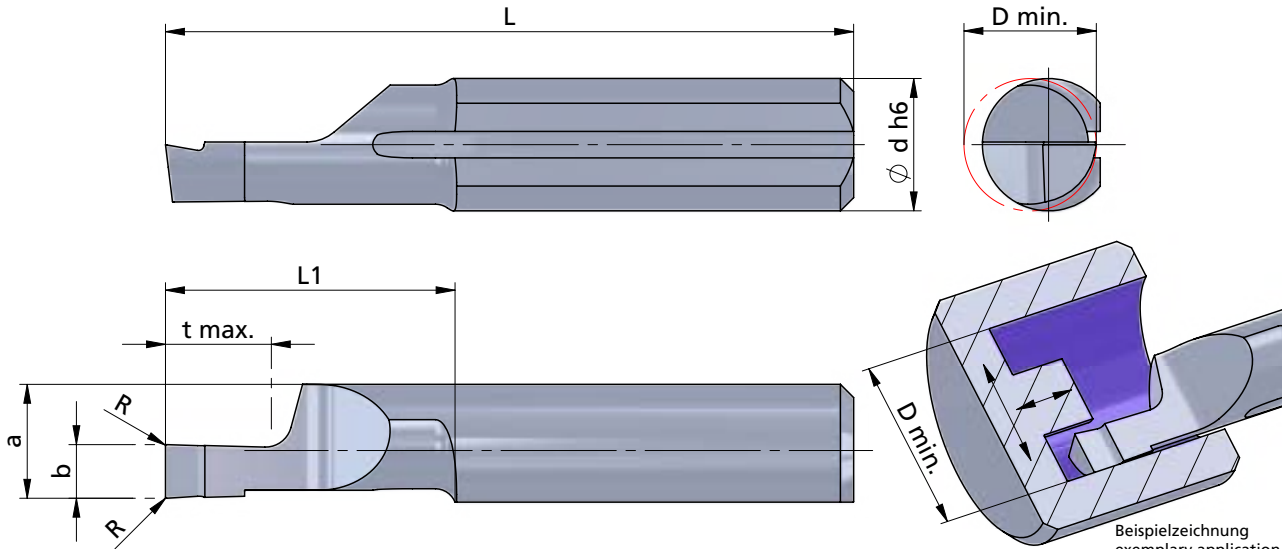

Rechts (R): wie gezeichnet
Links (L): spiegelbildlich

righthand (R): as shown
lefthand version (L): mirror image

Abmessungen in mm

dimensions in mm

Bestellnummer part number	b +0.05	b (inch)	a	L	L1	t max.	D min.	Ø d h6	R	Material				Klemmhalter Typ toolholder type	
										K10F	CN45F	AL41F	P07C		
⋮ ↙															
R/L 010M1008-30	1.0		5.9	45	30	2.0	8.0	7.0	0.1			●			
R/L 010M1508-30	1.5		5.9	45	30	3.0	8.0	7.0	0.1			●			
R/L 010M2008-30	2.0		5.9	45	30	4.0	8.0	7.0	0.1			●		670, ... 676, ... 687,7	
R/L 010M2508-30	2.5		5.9	45	30	5.0	8.0	7.0	0.1			●			
R/L 010M3008-30	3.0		5.9	45	30	6.0	8.0	7.0	0.1			●			

Weitere HM Sorten können Sie in der Sortenübersicht im Kapitel "Technische Hinweise" und der Preisliste finden.

More carbide grades you can find in the grades summary in the chapter "technical instructions" and in the price list.

Bestellbeispiel:
für rechte Ausführung und Sorte
R010M1008-30/AL41F

order-example:
righthand version and grade
R010M1008-30/AL41F

ULTRAMINI

Bohrungsbearbeitung
ab $\varnothing 0.2 \text{ mm}$

grooving, boring and profiling
starting at $\varnothing 0.2 \text{ mm}$

Typ P10M

Axialstechen
mit Eckenradius
und innerer Kühlmittelzufuhr

face grooving
with corner radius
and through coolant

Performanceline

D min. 8.0 mm
Stechtiefe t max. 6.0 mm
Nutbreite bis 3.0 mm

D min. 8.0 mm
depth of groove t max. 6.0 mm
width of groove up to 3.0 mm

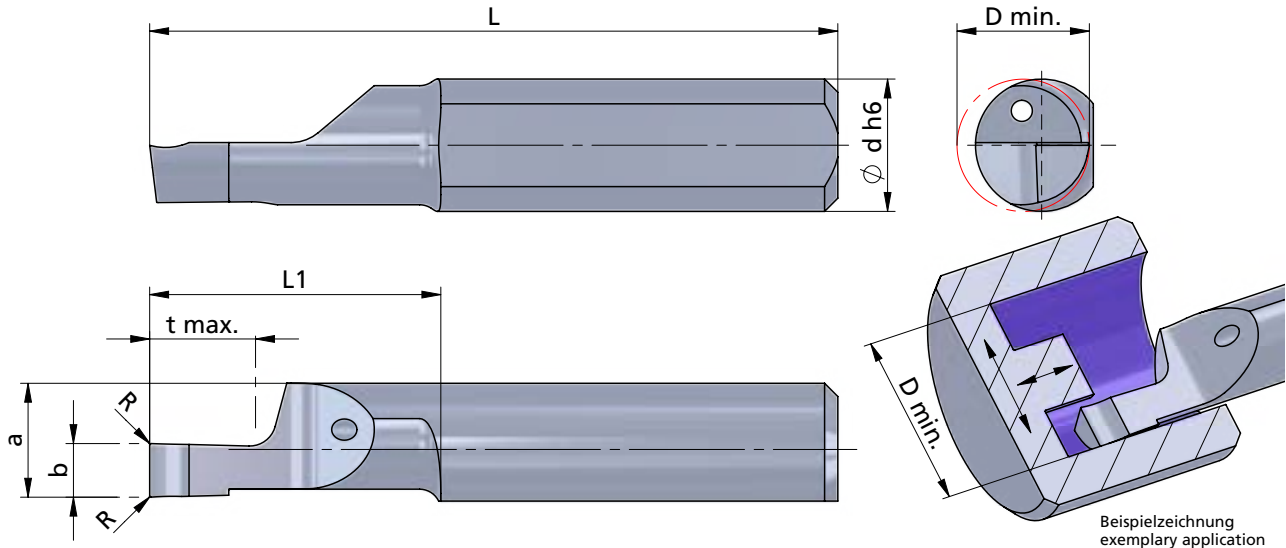

Rechts (R): wie gezeichnet
Links (L): spiegelbildlich

righthand (R): as shown
lefthand version (L): mirror image



Abmessungen in mm

dimensions in mm

Bestellnummer part number	b +0.05	b (inch)	a	L	L1	t max.	D min.	$\varnothing d h6$	R	Klemmhalter Typ toolholder type				
										K10F	P04C	AL41F	P07C	
R/L P10M1008-10	1.0		5.9	26	11	2.0	8.0	7.0	0.1	●				
R/L P10M1508-10	1.5		5.9	26	11	3.0	8.0	7.0	0.1	●				
R/L P10M1578-10	1.57	0.062"	5.9	26	11	3.0	8.0	7.0	0.1	●				
R/L P10M2008-10	2.0		5.9	26	11	4.0	8.0	7.0	0.1	●				
R/L P10M2508-10	2.5		5.9	26	11	5.0	8.0	7.0	0.1	●				
R/L P10M3008-10	3.0		5.9	26	11	6.0	8.0	7.0	0.1	●				
R/L P10M1008-20	1.0		5.9	35	20	2.0	8.0	7.0	0.1	●				670 ...
R/L P10M1508-20	1.5		5.9	35	20	3.0	8.0	7.0	0.1	●				676 ...
R/L P10M2008-20	2.0		5.9	35	20	4.0	8.0	7.0	0.1	●				687 ...
R/L P10M2308-20	2.38	0.094"	5.9	35	20	5.0	8.0	7.0	0.1	●				...7
R/L P10M2508-20	2.5		5.9	35	20	5.0	8.0	7.0	0.1	●				
R/L P10M3008-20	3.0		5.9	35	20	6.0	8.0	7.0	0.1	●				
↳ ...														

Weitere HM Sorten können Sie in der Sortenübersicht im Kapitel "Technische Hinweise" und der Preisliste finden.

Bestellbeispiel:
für rechte Ausführung und Sorte
RP10M1008-10/P04C

More carbide grades you can find in the grades summary in the chapter "technical instructions" and in the price list.

order-example:
righthand version and grade
RP10M1008-10/P04C

ULTRAMINI

Bohrungsbearbeitung
ab \varnothing 0.2 mm

grooving, boring and profiling
starting at \varnothing 0.2 mm

Typ P10M

Axialstechen
mit Eckenradius
und innerer Kühlmittelzufuhr

face grooving
with corner radius
and through coolant

Performanceline

D min. 8.0 mm
Stechtiefe t max. 6.0 mm
Nutbreite bis 3.0 mm

D min. 8.0 mm
depth of groove t max. 6.0 mm
width of groove up to 3.0 mm

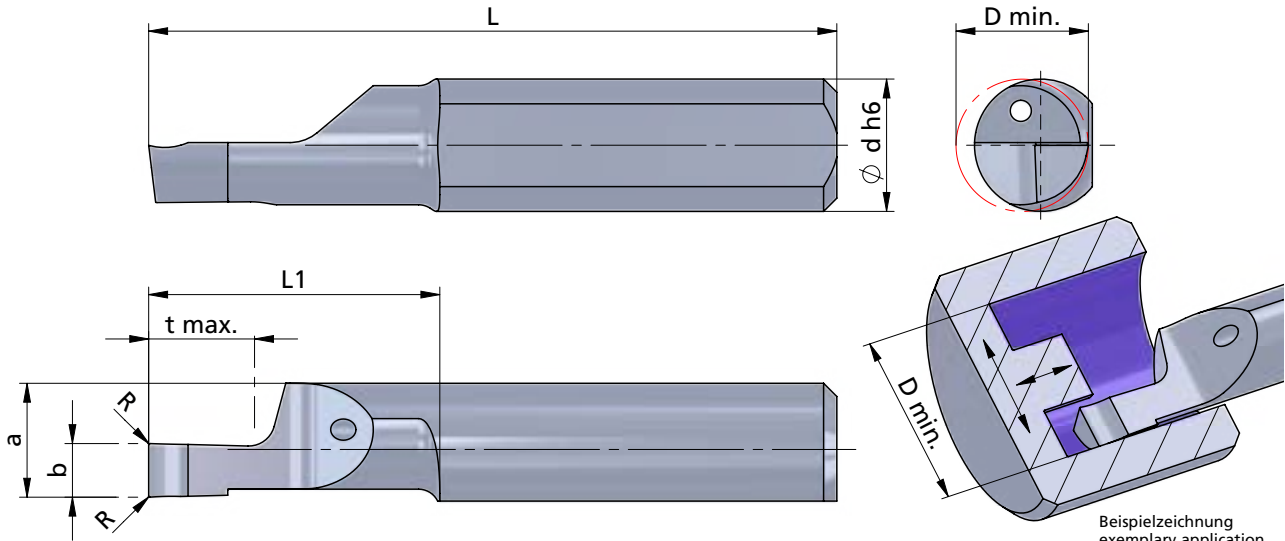
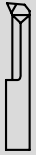

Rechts (R): wie gezeichnet
Links (L): spiegelbildlich

righthand (R): as shown
lefthand version (L): mirror image

Abmessungen in mm

dimensions in mm



Bestellnummer part number	b +0.05	b (inch)	a	L	L1	t max.	D min.	\varnothing d h6	R	Klemmhalter Typ toolholder type				
										K10F	P04C	AL41F	P07C	
⋮ ↙														
R/L P10M1008-30	1.0		5.9	45	30	2.0	8.0	7.0	0.1	●				
R/L P10M1508-30	1.5		5.9	45	30	3.0	8.0	7.0	0.1	●				
R/L P10M2008-30	2.0		5.9	45	30	4.0	8.0	7.0	0.1	●				
R/L P10M2508-30	2.5		5.9	45	30	5.0	8.0	7.0	0.1	●				
R/L P10M3008-30	3.0		5.9	45	30	6.0	8.0	7.0	0.1	●				
													670, ... 676, ... 687,7	

Weitere HM Sorten können Sie in der Sortenübersicht im Kapitel "Technische Hinweise" und der Preisliste finden.

More carbide grades you can find in the grades summary in the chapter "technical instructions" and in the price list.

Bestellbeispiel:
für rechte Ausführung und Sorte
RP10M1008-30/P04C

order-example:
righthand version and grade
RP10M1008-30/P04C

ULTRAMINI

Bohrungsbearbeitung
ab \varnothing 0.2 mm

grooving, boring and profiling
starting at \varnothing 0.2 mm

Typ 010P

Axialstechen
mit gelasertem Spanformer
und Eckenradius

face grooving
with lasered chipformer
and corner radius

Premiumline

D min. 8.0 mm
Stechtiefe t max. 6.0 mm
Nutbreite bis 3.0 mm

D min. 8.0 mm
depth of groove t max. 6.0 mm
width of groove up to 3.0 mm

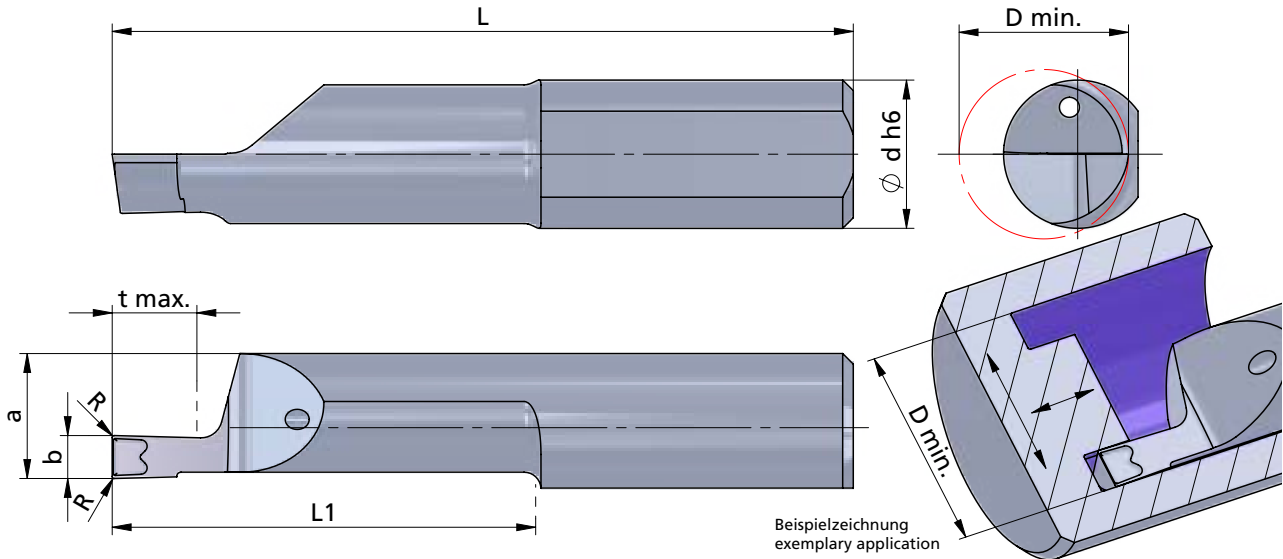

Rechts (R): wie gezeichnet
Links (L): spiegelbildlich

righthand (R): as shown
lefthand version (L): mirror image

Abmessungen in mm

dimensions in mm



Bestellnummer part number														Klemmhalter Typ toolholder type
	b +0.05	a	L	L1	t max.	D min.	\varnothing d h6	R	K10F	CN45F	AL41F	P07C		
R/L 010P1508-10	1.5	5.9	26	11	3.0	8.0	7.0	0.1					670... 676... 687... ...7	
R/L 010P1508-20	1.5	5.9	35	20	3.0	8.0	7.0	0.1						
R/L 010P1508-30	1.5	5.9	45	30	3.0	8.0	7.0	0.1						
R/L 010P2008-10	2.0	5.9	26	11	4.0	8.0	7.0	0.1						
R/L 010P2008-20	2.0	5.9	35	20	4.0	8.0	7.0	0.1						
R/L 010P2008-30	2.0	5.9	45	30	4.0	8.0	7.0	0.1						
R/L 010P2508-10	2.5	5.9	26	11	5.0	8.0	7.0	0.1						
R/L 010P2508-20	2.5	5.9	35	20	5.0	8.0	7.0	0.1						
R/L 010P2508-30	2.5	5.9	45	30	5.0	8.0	7.0	0.1						
R/L 010P3008-10	3.0	5.9	26	11	6.0	8.0	7.0	0.1						
R/L 010P3008-20	3.0	5.9	35	20	6.0	8.0	7.0	0.1						
R/L 010P3008-30	3.0	5.9	45	30	6.0	8.0	7.0	0.1						

Weitere HM Sorten können Sie in der Sortenübersicht im Kapitel "Technische Hinweise" und der Preisliste finden.

Bestellbeispiel:
für rechte Ausführung und Sorte
R010P1508-10/AL41F

More carbide grades you can find in the grades summary in the chapter "technical instructions" and in the price list.

order-example:
righthand version and grade
R010P1508-10/AL41F

ULTRAMINI

Bohrungsbearbeitung
ab Ø 0.2 mm

grooving, boring and profiling
starting at Ø 0.2 mm

Typ 010

Axialstechen
mit Vollradius

face grooving
with full radius

D min. 8.0 mm
Stechtiefe t max. 6.0 mm
Nutbreite bis 3.0 mm

D min. 8.0 mm
depth of groove t max. 6.0 mm
width of groove up to 3.0 mm

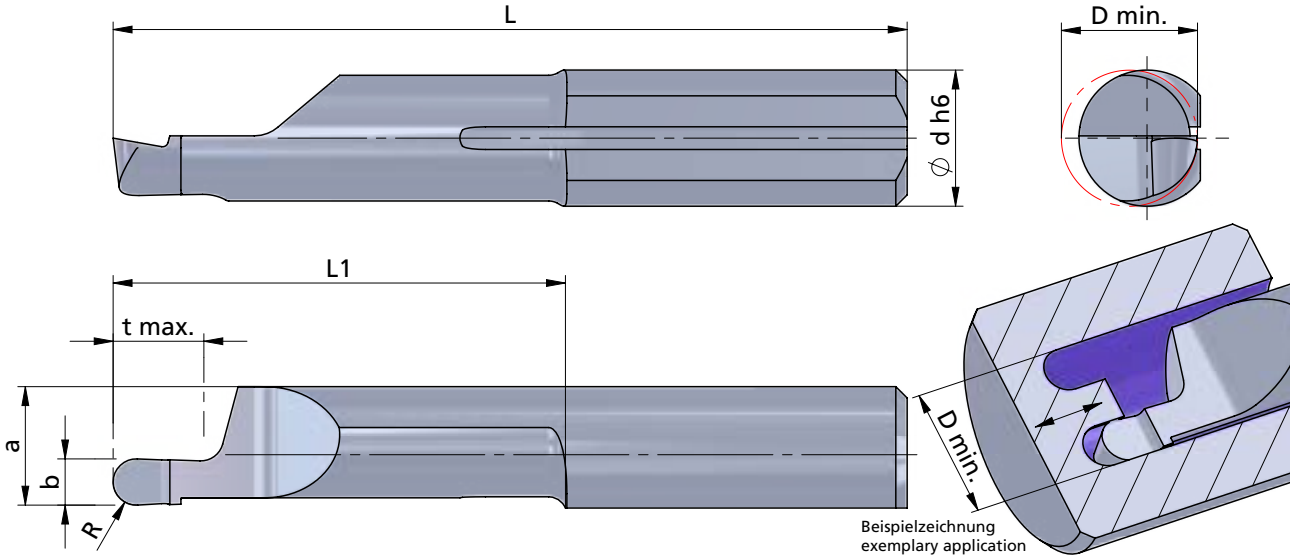
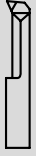

Rechts (R): wie gezeichnet
Links (L): spiegelbildlich

righthand (R): as shown
lefthand version (L): mirror image

Abmessungen in mm

dimensions in mm

Bestellnummer part number	b +0.05	b (inch)	R	a	L	L1	t max.	D min.	Ø d h6	Klemmhalter Typ				Klemmhalter Typ toolholder type
										K10F	CN45F	AL41F	PD2F	
R/L 010.1005-10	1.0		0.5	5.9	26	11	2.0	8.0	7.0			●	●	670... 676... 687... ...7
R/L 010.1507-10	1.57	0.062"	0.78	5.9	26	11	3.0	8.0	7.0			●		
R/L 010.1608-10	1.6		0.8	5.9	26	11	3.0	8.0	7.0			●	●	
R/L 010.1910-10	1.98	0.078"	0.99	5.9	26	11	4.0	8.0	7.0			●		
R/L 010.2010-10	2.0		1.0	5.9	26	11	4.0	8.0	7.0			●	●	
R/L 010.2512-10	2.5		1.25	5.9	26	11	5.0	8.0	7.0			●		
R/L 010.3015-10	3.0		1.5	5.9	26	11	6.0	8.0	7.0			●	●	
R/L 010.1005-20	1.0		0.5	5.9	35	20	2.0	8.0	7.0			●	●	
R/L 010.1608-20	1.6		0.8	5.9	35	20	3.0	8.0	7.0			●		
R/L 010.2010-20	2.0		1.0	5.9	35	20	4.0	8.0	7.0			●	●	
R/L 010.2512-20	2.5		1.25	5.9	35	20	5.0	8.0	7.0			●	●	
R/L 010.3015-20	3.0		1.5	5.9	35	20	6.0	8.0	7.0			●	●	

Weitere HM Sorten können Sie in der Sortenübersicht im Kapitel "Technische Hinweise" und der Preisliste finden.

More carbide grades you can find in the grades summary in the chapter "technical instructions" and in the price list.

Bestellbeispiel:
für rechte Ausführung und Sorte
R010.1005-10/AL41F

order-example:
righthand version and grade
R010.1005-10/AL41F

ULTRAMINI

Bohrungsbearbeitung
ab $\varnothing 0.2$ mm

grooving, boring and profiling
starting at $\varnothing 0.2$ mm

Typ P10

Axialstechen
mit Vollradius
und innerer Kühlmittelzufuhr

face grooving
with full radius
and through coolant

Performanceline

D min. 8.0 mm
Stechtiefe t max. 6.0 mm
Nutbreite bis 3.0 mm

D min. 8.0 mm
depth of groove t max. 6.0 mm
width of groove up to 3.0 mm

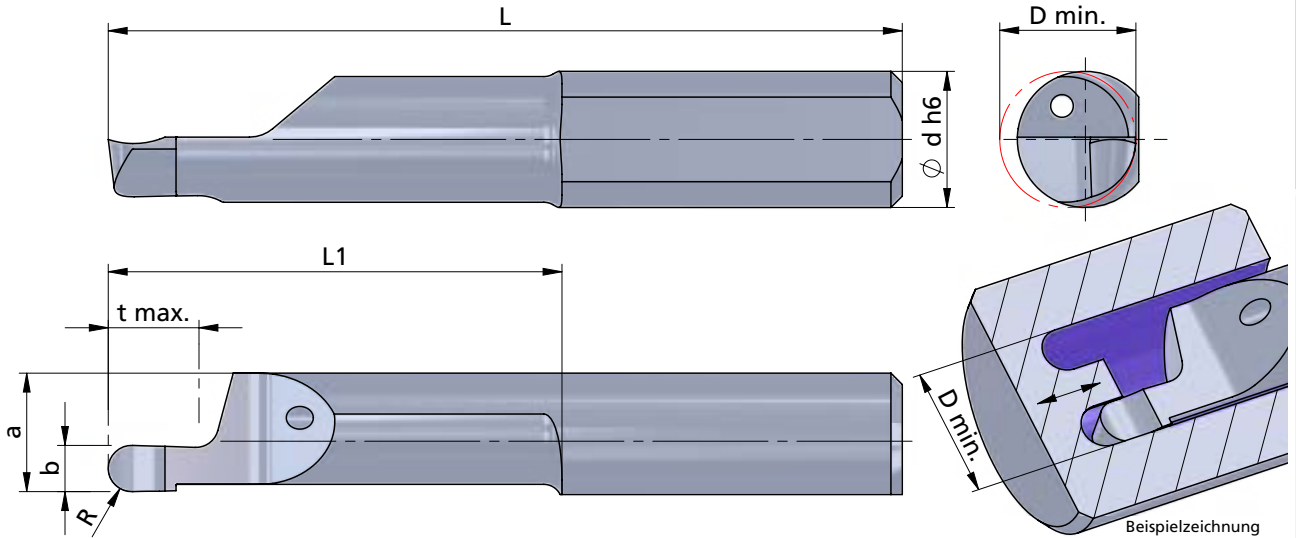

Beispielzeichnung
exemplary application

Rechts (R): wie gezeichnet
Links (L): spiegelbildlich

righthand (R): as shown
lefthand version (L): mirror image



Abmessungen in mm

dimensions in mm

Bestellnummer part number	b +0.05	b (inch)	R	a	L	L1	t max.	D min.	\varnothing d h6	Klemmhalter Typ toolholder type				
										K10F	P04C	AL41F	PD2F	
R/L P10.1005-10	1.0		0.5	5.9	26	11	2.0	8.0	7.0	●				
R/L P10.1507-10	1.57	0.062"	0.78	5.9	26	11	3.0	8.0	7.0	●				
R/L P10.1608-10	1.6		0.8	5.9	26	11	3.0	8.0	7.0	●				
R/L P10.1910-10	1.98	0.078"	0.99	5.9	26	11	4.0	8.0	7.0	●				
R/L P10.2010-10	2.0		1.0	5.9	26	11	4.0	8.0	7.0	●				
R/L P10.2512-10	2.5		1.25	5.9	26	11	5.0	8.0	7.0	●				
R/L P10.3015-10	3.0		1.5	5.9	26	11	6.0	8.0	7.0	●				
R/L P10.1005-20	1.0		0.5	5.9	35	20	2.0	8.0	7.0	●				
R/L P10.1608-20	1.6		0.8	5.9	35	20	3.0	8.0	7.0	●				
R/L P10.2010-20	2.0		1.0	5.9	35	20	4.0	8.0	7.0	●				
R/L P10.2512-20	2.5		1.25	5.9	35	20	5.0	8.0	7.0	●				
R/L P10.3015-20	3.0		1.5	5.9	35	20	6.0	8.0	7.0	●				

670...
676...
687...
...7

Weitere HM Sorten können Sie in der Sortenübersicht im Kapitel "Technische Hinweise" und der Preisliste finden.

Bestellbeispiel:
für rechte Ausführung und Sorte
RP10.1005-10/P04C

More carbide grades you can find in the grades summary in the chapter "technical instructions" and in the price list.

order-example:
righthand version and grade
RP10.1005-10/P04C

ULTRAMINI

Bohrungsbearbeitung
ab \varnothing 0.2 mm

grooving, boring and profiling
starting at \varnothing 0.2 mm

Typ 015

Axialstechen

face grooving

D min. 8.0 mm
Stechtiefe t max. 30 mm
Nutbreite bis 3.0 mm

D min. 8.0 mm
depth of groove t max. 30 mm
width of groove up to 3.0 mm

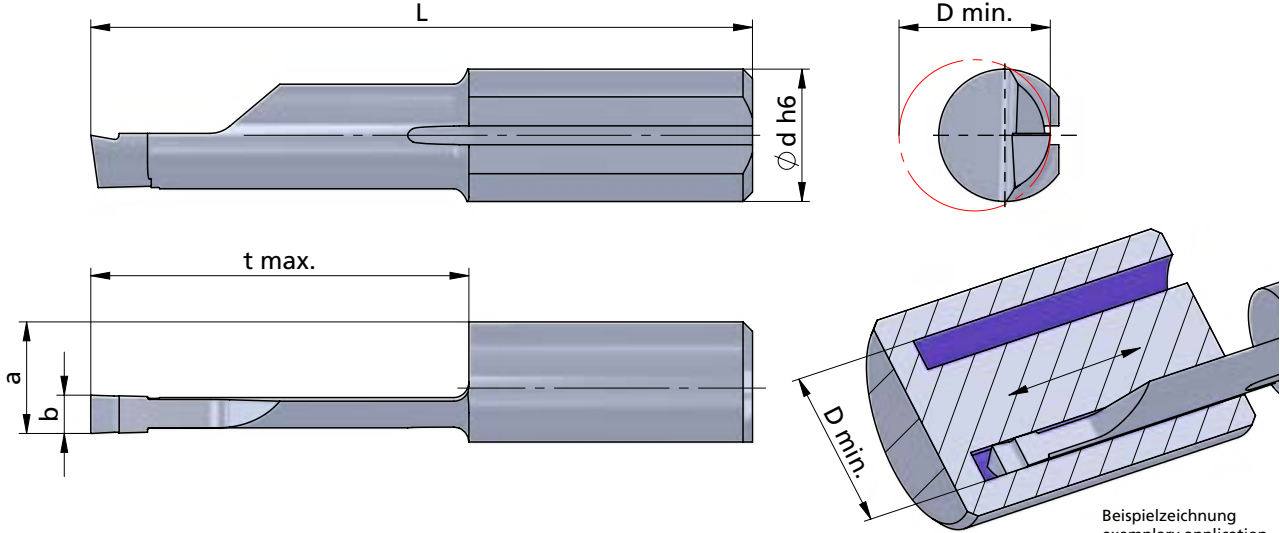

Beispielzeichnung
exemplary application

Rechts (R): wie gezeichnet
Links (L): spiegelbildlich

righthand (R): as shown
lefthand version (L): mirror image

Abmessungen in mm

dimensions in mm

Bestellnummer part number	b +0.05	a	L	t max.	D min.	Ø d h6	Klemmhalter Typ				toolholder type
							K10F	CN45F	AL41F	PD2F	
R/L 015.1515-10	1.5	5.9	26	10	8.0	7.0	●	●	●		
R/L 015.2015-15	2.0	5.9	30	15	8.0	7.0		●	●		
R/L 015.2015-20	2.0	5.9	35	20	8.0	7.0	●	●	●		
R/L 015.2515-20	2.5	5.9	35	20	8.0	7.0		●	●		670, ... 676, ... 687,7
R/L 015.3015-20	3.0	5.9	35	20	8.0	7.0	●	●	●		
R/L 015.3015-30	3.0	5.9	45	30	8.0	7.0		●	●		

Weitere HM Sorten können Sie in der Sortenübersicht im Kapitel "Technische Hinweise" und der Preisliste finden.

More carbide grades you can find in the grades summary in the chapter "technical instructions" and in the price list.

Bestellbeispiel:
für rechte Ausführung und Sorte
R015.1515-10/AL41F

order-example:
righthand version and grade
R015.1515-10/AL41F

ULTRAMINI

Bohrungsbearbeitung
ab $\varnothing 0.2$ mm

grooving, boring and profiling
starting at $\varnothing 0.2$ mm

Typ 015M

Axialstechen
mit Eckenradius

face grooving
with corner radius

D min. 8.0 mm
Stechtiefe t max. 30 mm
Nutbreite bis 3.0 mm

D min. 8.0 mm
depth of groove t max. 30 mm
width of groove up to 3.0 mm

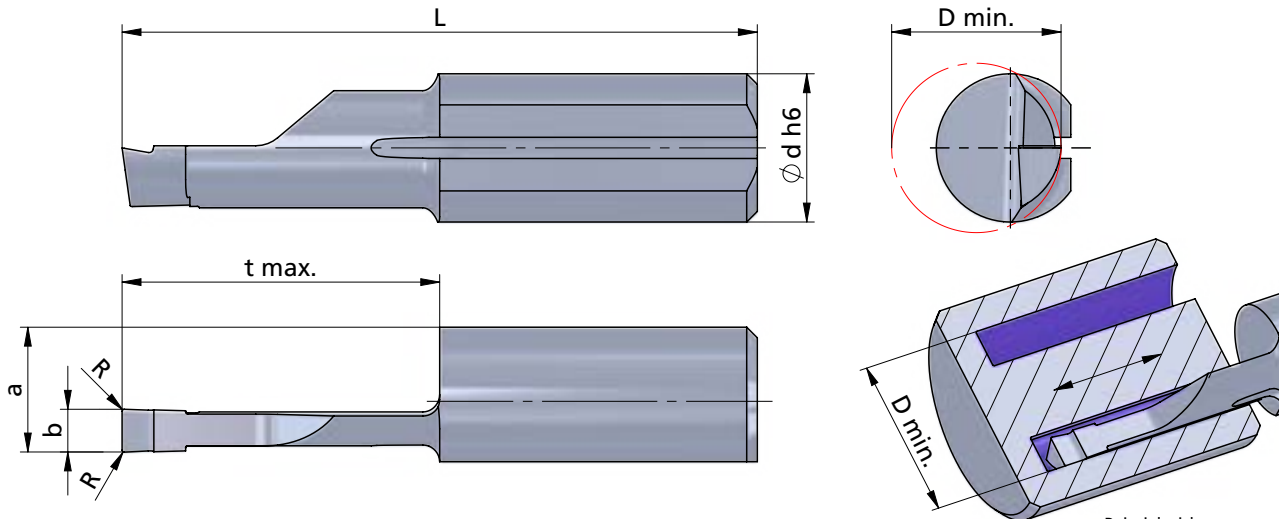

Beispielzeichnung
exemplary application

Rechts (R): wie gezeichnet
Links (L): spiegelbildlich

righthand (R): as shown
lefthand version (L): mirror image

Abmessungen in mm

dimensions in mm

Bestellnummer part number	b +0.05	a	L	t max.	D min.	Ø d h6	R	Klemmhalter Typ				toolholder type
								K10F	CN45F	AL41F	PD2F	
R/L 015M1515-10	1.5	5.9	26	10	8.0	7.0	0.1					
R/L 015M2015-15	2.0	5.9	30	15	8.0	7.0	0.1					
R/L 015M2015-20	2.0	5.9	35	20	8.0	7.0	0.1					
R/L 015M2515-20	2.5	5.9	35	20	8.0	7.0	0.1					670... 676... 687... ...7
R/L 015M3015-20	3.0	5.9	35	20	8.0	7.0	0.1					
R/L 015M3015-30	3.0	5.9	45	30	8.0	7.0	0.1					

Weitere HM Sorten können Sie in der Sortenübersicht im Kapitel "Technische Hinweise" und der Preisliste finden.

Bestellbeispiel:
für rechte Ausführung und Sorte
R015M1515-10/AL41F

More carbide grades you can find in the grades summary in the chapter "technical instructions" and in the price list.

order-example:
righthand version and grade
R015M1515-10/AL41F

ULTRAMINI

Bohrungsbearbeitung
ab $\varnothing 0.2$ mm

grooving, boring and profiling
starting at $\varnothing 0.2$ mm

Typ 012 / 016

Axialstechen
mit Eckenradius
und doppeltem Kühlkanal

face grooving
with corner radius
and double internal cooling

D min. 12 mm
Stechtiefe t max. 20 mm
Nutbreite bis 4.0 mm

D min. 12 mm
depth of groove t max. 20 mm
width of groove up to 4.0 mm

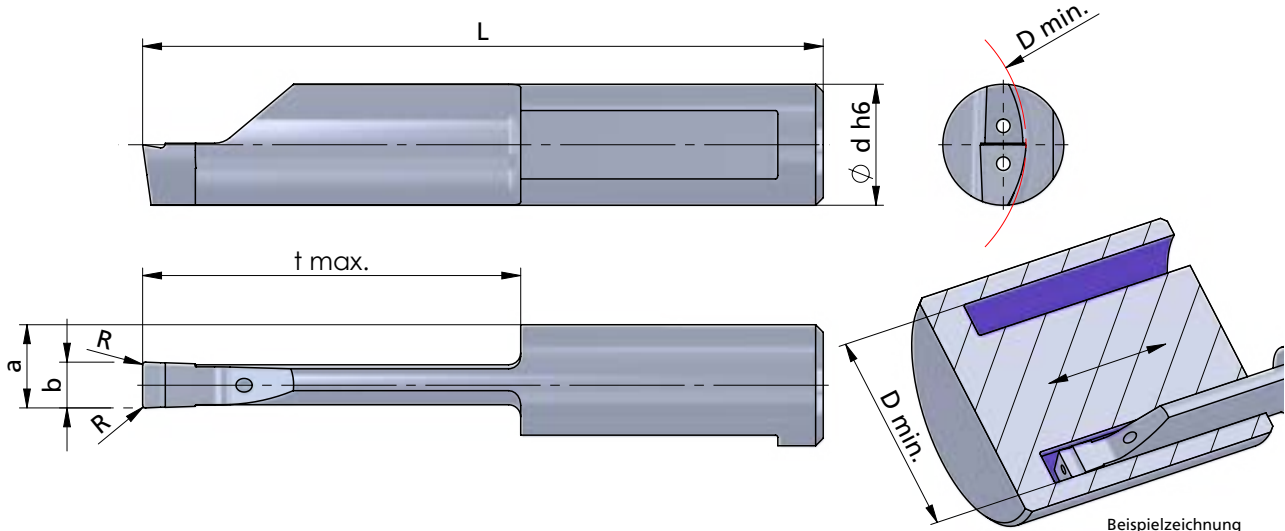

Rechts (R): wie gezeichnet
Links (L): spiegelbildlich

Kühlmitteldruckempfehlung
70 bar

Abmessungen in mm

righthand (R): as shown
lefthand version (L): mirror image

Coolant pressure recommendation
70 bar

dimensions in mm



Beispielzeichnung
exemplary application

Bestellnummer part number	b +0.05	a	L	t max.	D min.	Ø d h6	R	Klemmhalter Typ				Klemmhalter Typ toolholder type
								K10F	CN45F	AL41F	PD2F	
R/L 012.0200-10	2.0	5.00	30	10	12	8.0	0.2					680... 681... 687... ...8
R/L 012.0200-15	2.0	5.00	35	15	12	8.0	0.2					
R/L 012.0250-10	2.5	5.25	30	10	12	8.0	0.2					
R/L 012.0250-20	2.5	5.25	40	20	12	8.0	0.2					
R/L 016.0300-10	3.0	5.50	30	10	16	8.0	0.2					
R/L 016.0300-20	3.0	5.50	40	20	16	8.0	0.2					
R/L 016.0400-10	4.0	6.00	30	10	16	8.0	0.2					
R/L 016.0400-20	4.0	6.00	40	20	16	8.0	0.2					

Weitere HM Sorten können Sie in der Sortenübersicht im Kapitel "Technische Hinweise" und der Preisliste finden.

Bestellbeispiel:
für rechte Ausführung und Sorte
R012.0200-10/AL41F

More carbide grades you can find in the grades summary in the chapter "technical instructions" and in the price list.

order-example:
righthand version and grade
R012.0200-10/AL41F

ULTRAMINI

Bohrungsbearbeitung
ab $\varnothing 0.2$ mm

grooving, boring and profiling
starting at $\varnothing 0.2$ mm

Typ 020

Axialstechen
mit Eckenradius
und doppeltem Kühlkanal

face grooving
with corner radius
and double internal cooling

D min. 20 mm
Stechtiefe t max. 40 mm
Nutbreite bis 5.0 mm

D min. 20 mm
depth of groove t max. 40 mm
width of groove up to 5.0 mm

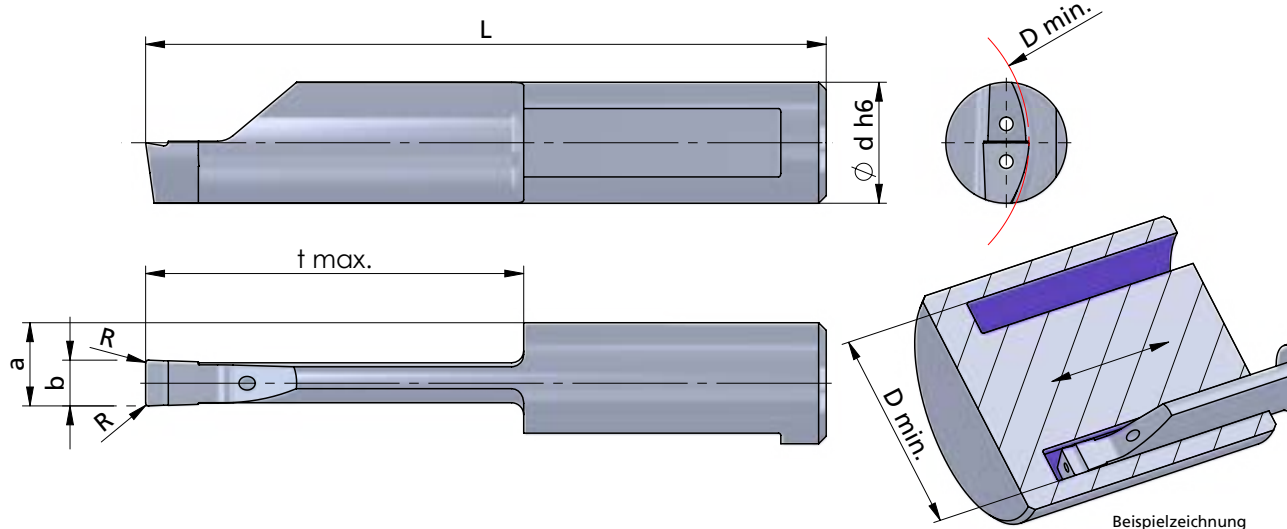

Beispielzeichnung
exemplary application

Rechts (R): wie gezeichnet
Links (L): spiegelbildlich

Kühlmitteldruckempfehlung
70 bar

Abmessungen in mm

righthand (R): as shown
lefthand version (L): mirror image

Coolant pressure recommendation
70 bar

dimensions in mm



Bestellnummer part number	b +0.05	a	L	t max.	D min.	Ø d h6	R					Klemmhalter Typ toolholder type
								K10F	CN45F	AL41F	PD2F	
R/L 020.0300-25	3.0	5.5	45	25	20	8.0	0.2			●	●	680... 681... 687... ...8
R/L 020.0300-30	3.0	5.5	50	30	20	8.0	0.2			●	●	
R/L 020.0300-35	3.0	5.5	55	35	20	8.0	0.2			●	●	
R/L 020.0300-40	3.0	5.5	60	40	20	8.0	0.2			●	●	
R/L 020.0400-25	4.0	6.0	45	25	20	8.0	0.2			●	●	
R/L 020.0400-30	4.0	6.0	50	30	20	8.0	0.2			●	●	
R/L 020.0400-35	4.0	6.0	55	35	20	8.0	0.2			●	●	
R/L 020.0400-40	4.0	6.0	60	40	20	8.0	0.2			●	●	
R/L 020.0500-20	5.0	6.5	40	20	20	8.0	0.2			●	●	
R/L 020.0500-25	5.0	6.5	45	25	20	8.0	0.2			●	●	
R/L 020.0500-30	5.0	6.5	50	30	20	8.0	0.2			●	●	
R/L 020.0500-35	5.0	6.5	55	35	20	8.0	0.2			●	●	
R/L 020.0500-40	5.0	6.5	60	40	20	8.0	0.2			●	●	

Weitere HM Sorten können Sie in der Sortenübersicht im Kapitel "Technische Hinweise" und der Preisliste finden.

Bestellbeispiel:
für rechte Ausführung und Sorte
R020.0300-25/AL41F

More carbide grades you can find in the grades summary in the chapter "technical instructions" and in the price list.

order-example:
righthand version and grade
R020.0300-25/AL41F

ULTRAMINI

Bohrungsbearbeitung
ab $\varnothing 0.2$ mm

grooving, boring and profiling
starting at $\varnothing 0.2$ mm

Typ 012 / 020

Axialstechen
mit Vollradius
und doppeltem Kühlkanal

face grooving
with full radius
and double internal cooling

D min. 12 / 20 mm
Stechtiefe t max. 20 / 30 mm
Nutbreite bis 3.0 / 4.0 mm

D min. 12 / 20 mm
depth of groove t max. 20 / 30 mm
width of groove up to 3.0 / 4.0 mm

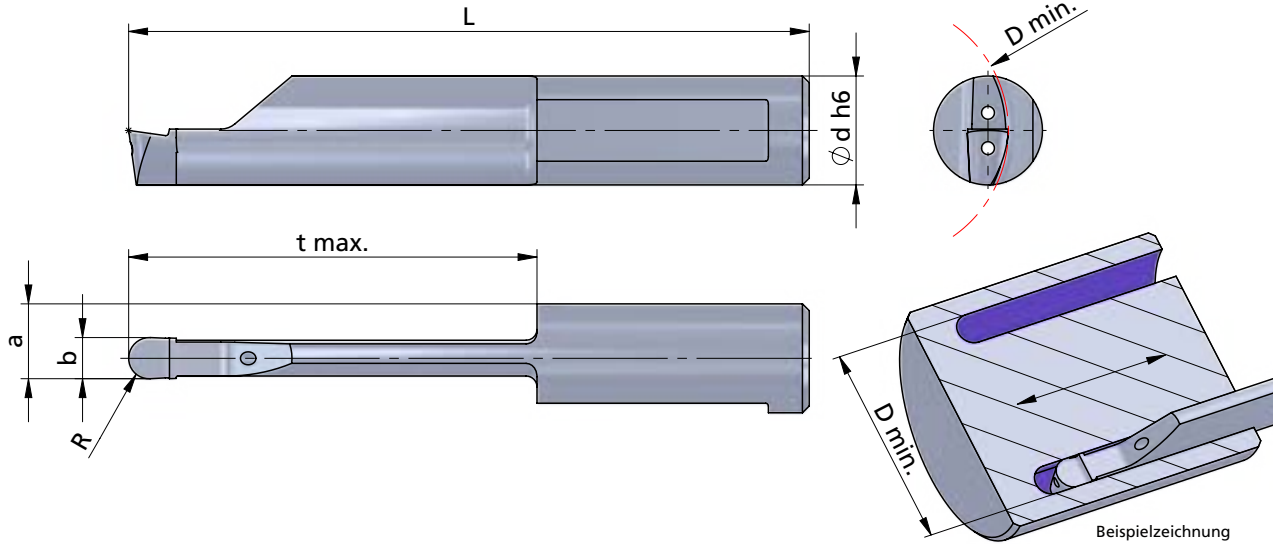

Beispielzeichnung
exemplary application

Rechts (R): wie gezeichnet
Links (L): spiegelbildlich

Kühlmitteldruckempfehlung
70 bar

Abmessungen in mm

righthand (R): as shown
lefthand version (L): mirror image

Coolant pressure recommendation
70 bar

dimensions in mm



Bestellnummer part number	b +0.05	R	a	L	t max.	D min.	$\varnothing d h6$	K10F CN45F AL41F P07C	Klemmhalter Typ	toolholder type
R/L 012.2010-15	2.0	1.0	5.00	35	15	12	8.0			
R/L 012.2512-20	2.5	1.25	5.25	40	20	12	8.0			
R/L 012.3015-20	3.0	1.5	5.50	40	20	12	8.0			680... 681... 687... ...8
R/L 020.3015-30	3.0	1.5	5.50	50	30	20	8.0			
R/L 020.4020-30	4.0	2.0	6.00	50	30	20	8.0			

Weitere HM Sorten können Sie in der Sortenübersicht im Kapitel "Technische Hinweise" und der Preisliste finden.

Bestellbeispiel:
für rechte Ausführung und Sorte
R012.2010-15/AL41F

More carbide grades you can find in the grades summary in the chapter "technical instructions" and in the price list.

order-example:
righthand version and grade
R012.2010-15/AL41F

ULTRAMINI

Bohrungsbearbeitung
ab \varnothing 0.2 mm

grooving, boring and profiling
starting at \varnothing 0.2 mm

Typ 520

Fasen

D min. 1.0 mm
Stechtiefe t max. 4.0 mm

chamfering

D min. 1.0 mm
depth of groove t max. 4.0 mm

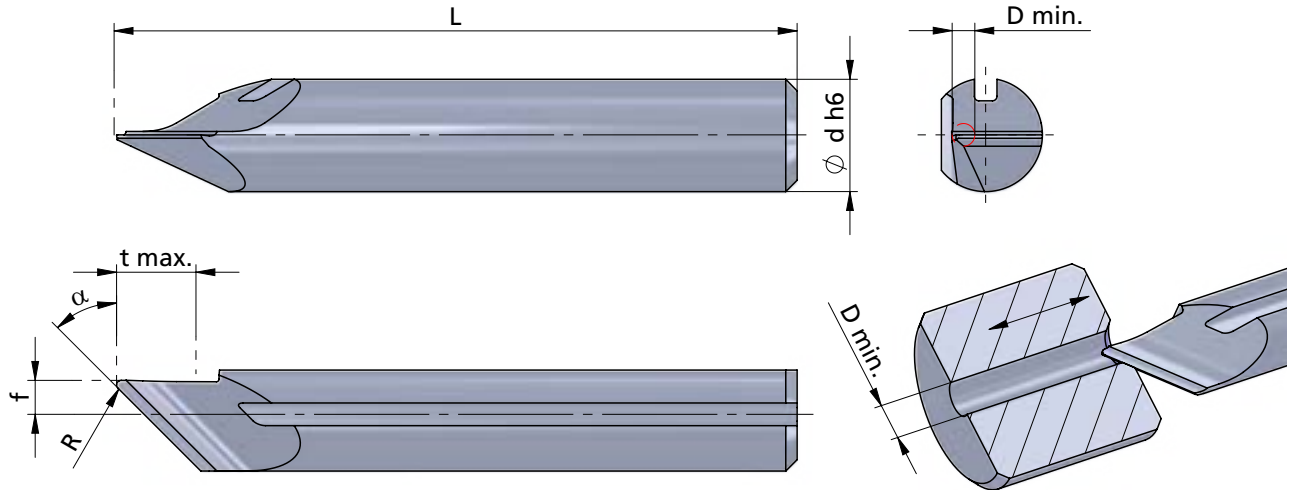

Beispielzeichnung
exemplary application

Rechts (R): wie gezeichnet
Links (L): spiegelbildlich

righthand (R): as shown
lefthand version (L): mirror image

Abmessungen in mm

dimensions in mm

Bestellnummer part number	α	f	L	t max.	D min.	\varnothing d h6	R	Klemmhalter Typ				toolholder type
								K10F	CN45F	AL41F	PD2F	
R/L 520.0045-15	45°	1.5	30	3.5	1.0	5.0	0.2			●		645... 650... ...5
R/L 520.0060-15	60°	1.5	30	4.0	1.0	5.0	0.2	●		●		

Weitere HM Sorten können Sie in der Sortenübersicht im Kapitel "Technische Hinweise" und der Preisliste finden.

Bestellbeispiel:
für rechte Ausführung und Sorte
R520.0045-15/AL41F

More carbide grades you can find in the grades summary in the chapter "technical instructions" and in the price list.

order-example:
righthand version and grade
R520.0045-15/AL41F

ULTRAMINI

Bohrungsbearbeitung
ab \varnothing 0.2 mm

grooving, boring and profiling
starting at \varnothing 0.2 mm

Typ 52P

Fasen
mit innerer Kühlmittelzufuhr

chamfering
with through coolant

Performanceline

D min. 1.0 mm
Stechtiefe t max. 4.0 mm

D min. 1.0 mm
depth of groove t max. 4.0 mm

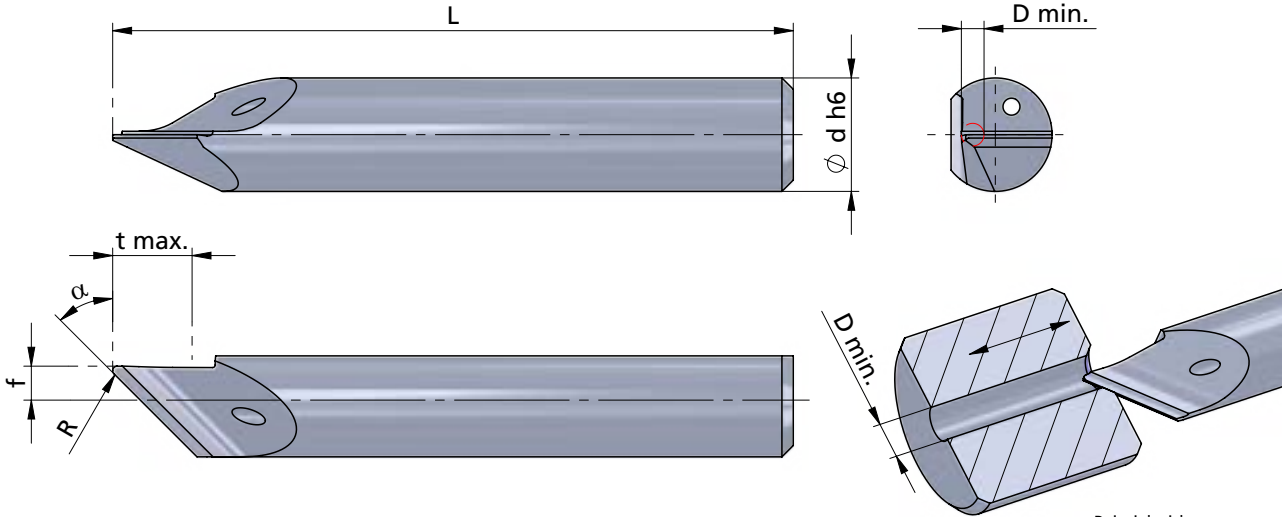
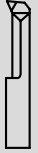

Rechts (R): wie gezeichnet
Links (L): spiegelbildlich

righthand (R): as shown
lefthand version (L): mirror image



Abmessungen in mm

dimensions in mm

Bestellnummer part number	α	f	L	t max.	D min.	\varnothing d h6	R	Klemmhalter Typ				toolholder type
								K10F	P04C	AL41F	PD2F	
R/L 52P.0045-15	45°	1.5	30	3.5	1.0	5.0	0.2	●				645... 650... ...5
R/L 52P.0060-15	60°	1.5	30	4.0	1.0	5.0	0.2	●				

Weitere HM Sorten können Sie in der Sortenübersicht im Kapitel "Technische Hinweise" und der Preisliste finden.

More carbide grades you can find in the grades summary in the chapter "technical instructions" and in the price list.

Bestellbeispiel:
für rechte Ausführung und Sorte
R52P.0045-15/P04C

order-example:
righthand version and grade
R52P.0045-15/P04C

ULTRAMINI

Bohrungsbearbeitung
ab \varnothing 0.2 mm

grooving, boring and profiling
starting at \varnothing 0.2 mm

Impressionen

impressions

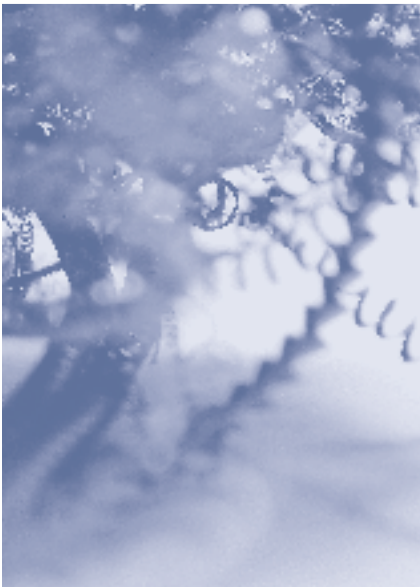
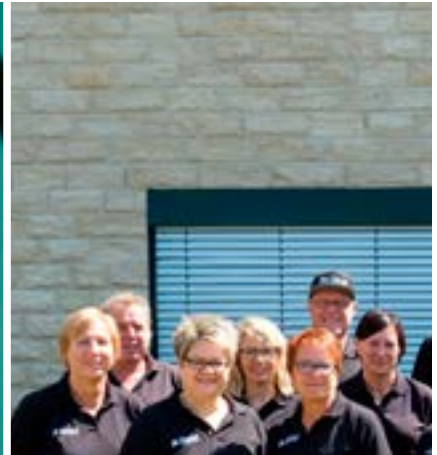

ULTRAMINI

Bohrungsbearbeitung
ab Ø 0.2 mm

grooving, boring and profiling
starting at Ø 0.2 mm

Sets

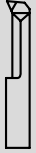

Bestellnummer
part number

Inhalt
content

K10F
AL41F
P18C
CN45F

SET.1

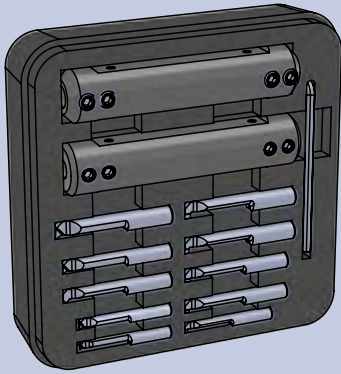

- Ausdrehen und Kopieren (Rechte Ausführung)
- Ausdrehen und Fasen (Rechte Ausführung)
- Stechdrehen (Rechte Ausführung)

- boring and profiling (righthand version)
- boring and chamfering (righthand version)
- grooving (righthand version)

Halter / toolholder:

- 1 x 676.0016-D
- 1 x 645.0016-D

Schneideinsatz / insert:

- 1 x R050.6-22
- 1 x R050.5-20
- 1 x R060.5-20
- 1 x R050.4-16
- 1 x R050.3-16
- 1 x R006.0200-22
- 1 x R006.0150-22
- 1 x R005.0200-20
- 1 x R005.0150-20
- 1 x R004.0100-16

-
-
-
-
-
-
-
-
-
-

Bestellnummer
part number

Inhalt
content

K10F
AL41F
P18C
CN45F

SET.2

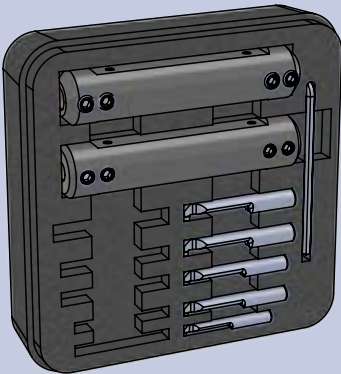

- Stechdrehen (Rechte Ausführung)

- grooving (righthand version)

Halter / toolholder:

- 1 x 676.0016-D
- 1 x 645.0016-D

Schneideinsatz / insert:

- 1 x R006.0200-22
- 1 x R006.0150-22
- 1 x R005.0200-20
- 1 x R005.0150-20
- 1 x R004.0100-16

-
-
-
-
-

Weitere Ausführungen auf Anfrage oder in der Preisliste.

More versions on request and in the price list.

ULTRAMINI

Bohrungsbearbeitung
ab Ø 0.2 mm

grooving, boring and profiling
starting at Ø 0.2 mm

Sets

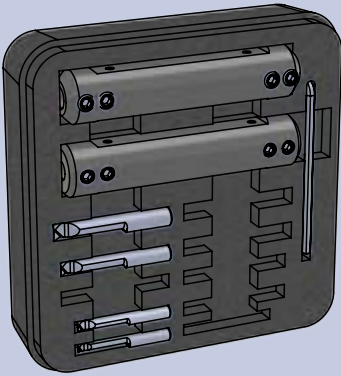
	Bestellnummer part number	Inhalt content	K10F AL41F P18C CN45F
	<p>SET.3</p> <ul style="list-style-type: none"> • Ausdrehen und Kopieren (Rechte Ausführung) • boring and profiling (righthand version) 	<p>Halter / toolholder:</p> <p>1 x 676.0016-D 1 x 645.0016-D</p> <p>Schneideinsatz / insert:</p> <p>1 x R050.6-22 1 x R050.5-20 1 x R050.4-16 1 x R050.3-16</p>	<p>● ● ● ●</p>

	Bestellnummer part number	Inhalt content	K10F AL41F P18C CN45F
	<p>SET.6R</p> <ul style="list-style-type: none"> • Axialstechen (Rechte Ausführung) • face grooving (righthand version) 	<p>Halter / toolholder:</p> <p>1 x 676.0016-D</p> <p>Schneideinsatz / insert:</p> <p>1 x R010.2508-20 1 x R010.2008-10 1 x R010.1508-10 1 x R010.3008-20 1 x R010.1008-10</p>	<p>● ● ● ● ●</p>

Weitere Ausführungen auf Anfrage oder in der Preisliste.

Bestellbeispiel:
SET.3

More versions on request and in the price list.

order-example:
SET.3

ULTRAMINI

Bohrungsbearbeitung
ab \varnothing 0.2 mm

grooving, boring and profiling
starting at \varnothing 0.2 mm

Sets



Bestellnummer
part number

Inhalt
content

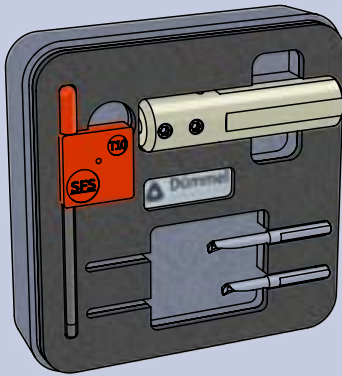

SET-RDT-4

- Bohren und Ausdrehen
(Rechte Ausführung)
- D min. 3,7

- drilling and boring
(righthand version)
- D min. 3,7

Halter / toolholder:

1 x 640P.DT16

Schneideinsatz / insert:

1 x RDT.4-15

1 x RDT.4-20

Bestellnummer
part number

Inhalt
content

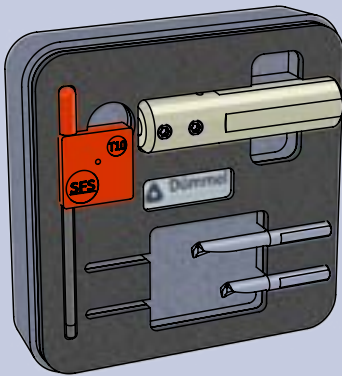

SET-RDT-5

- Bohren und Ausdrehen
(Rechte Ausführung)
- D min. 4,7

- drilling and boring
(righthand version)
- D min. 4,7

Halter / toolholder:

1 x 650P.DT16

Schneideinsatz / insert:

1 x RDT.5-15

1 x RDT.5-25

ULTRAMINI

Bohrungsbearbeitung
ab \varnothing 0.2 mm

grooving, boring and profiling
starting at \varnothing 0.2 mm

Sets

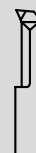

Bestellnummer
part number

Inhalt
content

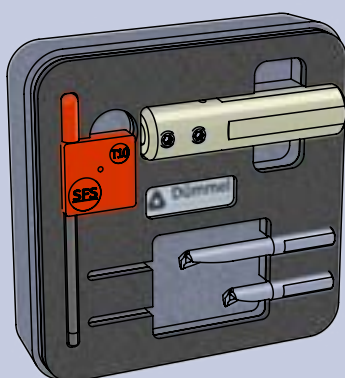

SET-RDT-6

- Bohren und Ausdrehen
(Rechte Ausführung)
- D min. 5,7

- drilling and boring
(righthand version)
- D min. 5,7

Halter / toolholder:

1 x 660R.DT16

Schneideinsatz / insert:

1 x RDT.6-15

1 x RDT.6-30

Bestellnummer
part number

Inhalt
content

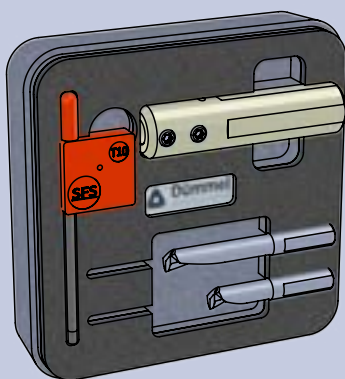

SET-RDT-7

- Bohren und Ausdrehen
(Rechte Ausführung)
- D min. 6,7

- drilling and boring
(righthand version)
- D min. 6,7

Halter / toolholder:

1 x 670R.DT16

Schneideinsatz / insert:

1 x RDT.7-20

1 x RDT.7-35

ULTRAMINI

Bohrungsbearbeitung
ab Ø 0.2 mm

grooving, boring and profiling
starting at Ø 0.2 mm

Sets

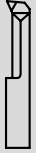

Bestellnummer
part number

Inhalt
content

K10F
AL41F
P18C
CN45F

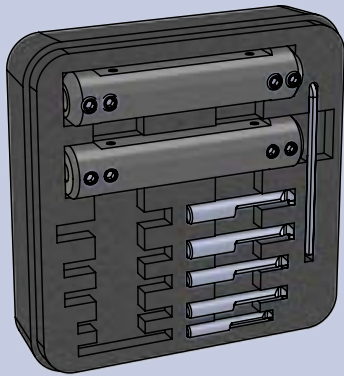

SET.2/LINKS

- Stechrehen
(linke Ausführung)

- grooving
(lefthand version)

Halter / toolholder:

- 1 x 676.0016-D
- 1 x 645.0016-D

Schneideinsatz / insert:

- 1 x L004.0100-16
- 1 x L005.0150-20
- 1 x L005.0200-20
- 1 x L006.0150-22
- 1 x L006.0200-22

Bestellnummer
part number

Inhalt
content

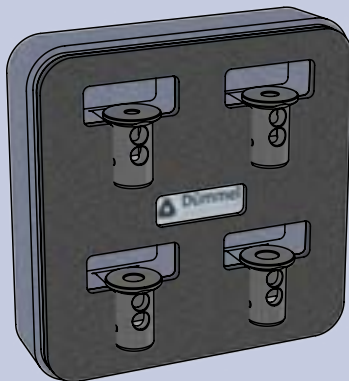

SET-RBD12

- Reduzierhülsen für Halter:

- Typ UMHB
- Typ UM.RBD12.00
- Typ UM.WFB
- Typ UM.C

- reduction bushes for toolholder:

- Typ UMHB
- Typ UM.RBD12.00
- Typ UM.WFB
- Typ UM.C

Halter / toolholder:

nicht enthalten/
not included

Reduzierhülsen / reduction bushes:

- 1 x UMHB-RBD1204
- 1 x UMHB-RBD1205
- 1 x UMHB-RBD1206
- 1 x UMHB-RBD1207

ULTRAMINI

Bohrungsbearbeitung
ab \varnothing 0.2 mm

grooving, boring and profiling
starting at \varnothing 0.2 mm

Impressionen

impressions



ULTRAMINI

Bohrungsbearbeitung
ab \varnothing 0.2 mm

grooving, boring and profiling
starting at \varnothing 0.2 mm

Technische Hinweise

Grundsätzliche Informationen
zum Werkzeugprogramm Ultramini

Technical instructions
Basic informations about
the tool program Ultramini



Spitzenhöhe Ultramini:

Die Plattensitze der Ultramini-Werkzeuge garantieren eine exakte Position auf Spitzenhöhe. Trotzdem ist immer auf die Spitzenhöhe zu achten, denn Abweichungen können besonders bei der Bearbeitung kleinster Durchmesser Probleme bereiten.

Centre height Ultramini:

The seatings of the Ultramini tools guarantee a accurate centre height of these tools. In spite of this please have always a look at your tools because a difference may cause problems, especially when machining small diameters.

Späneabfuhr Ultramini:

Bitte wählen Sie schmale Schneidbreiten, damit der Span geschmeidig bleibt und am Werkzeug vorbei aus der Bohrung fließen kann. Um einen Spänestau zu vermeiden ist stufenförmig oder mit Schnittunterbrechung zu stechen.

Removal of chips Ultramini:

Please choose inserts with small cutting width, so the chips keep smoothly and will be able to flow out of the bore beside the tool. To avoid jam of chips use the technique to groove by steps.

Kühlmittel Ultramini:

Verwenden Sie gefiltertes Kühlmittel um die Späne auszuspülen und die Schneide zu kühlen. Ein Kühlmitteldruck von mindestens 5 bar wird empfohlen.

Coolant Ultramini:

Use filtered coolant for transporting the chips out and for cooling the insert itself. A coolant pressure of 5 bar minimum is recommended.

ULTRAMINI

Bohrungsbearbeitung
ab Ø 0.2 mm

grooving, boring and profiling
starting at Ø 0.2 mm

Technische Hinweise

Allgemeine Informationen zum
Gewindeschneiden

Technical instructions
General informations about threading



Empfohlene Anzahl der Schnitte

Die Anzahl der Schnitte ist nur ein Richtwert für das Gewindedrehen. Um eine möglichst lange Standzeit der Schneide zu erreichen beachten Sie bitte die Erklärungen für die Zustellung.

Leerschnitte zum Fertigschneiden sind in dieser Tabelle nicht berücksichtigt.

Recommended number of passes

The number of passes is only a recommendation for threading. To reach a good tool life you have to mention the explanation for the infeed.

Finishing passes are not considered in that chart.

	Stahl (Festigkeit N/mm ²) Steel (N/mm ² tensile strength)					rostfreier Stahl stainless steel	Guss cast iron	Aluminium aluminium	
	400-500	500-700	700-850	850-1150	>1150				
V m/min	160	140	120	90	70	90	100	300	
Steigung P Pitch P		Anzahl der Schnitte number of passes							
mm	Gg/" TPI								
0,5	48	5	5	5	5	8	8	5	5
0,8	32	6	6	6	6	8	8	6	6
1	24	7	7	7	7	8	8	7	7
1,25	20-19	8	8	8	8	10	10	8	8
1,5	16	10	10	10	10	12	12	10	10
1,75	14	12	12	12	12	14	14	12	12
2	12-11	13	13	13	13	15	15	13	13
2,5	10	15	15	16	16	18	18	16	15
3 - 3,5	8	16	16	17	17	20	20	17	16
4		18	18	19	19	22	22	19	18
5		20	20	21	21	24	24	21	20
6		22	22	23	23	26	26	23	22

ULTRAMINI

Bohrungsbearbeitung
ab $\varnothing 0.2 \text{ mm}$

grooving, boring and profiling
starting at $\varnothing 0.2 \text{ mm}$

Technische Hinweise

Allgemeine Informationen zum
Gewindeschneiden

Technical instructions
General informations about threading

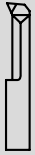

Vorschubrichtung

Mit jedem Schneideinsatz für das Gewindedrehen kann sowohl ein Rechts- wie auch ein Linksgewinde geschnitten werden. Hierbei ist folgende Vorschubrichtung zu beachten:

Feed direction

Every insert can be used for right- and lefthand thread. You only have to consider the following feed direction:

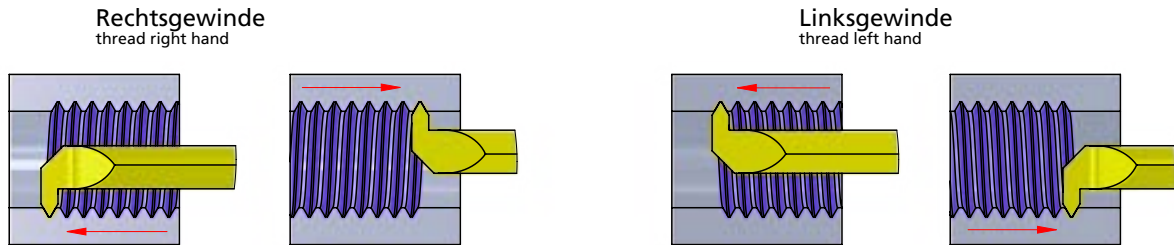

Zustellungsvarianten

Radiale Zustellung	wechselnde Flankenzustellung	einseitige Flankenzustellung
Die meist verwendete Methode um Gewinde herstellen. Beide Schneiden sind gleichzeitig im Eingriff.	Die Schneiden werden wechselnd eingesetzt.	Nur eine Schneidewird für die komplette Gewindefstellung eingesetzt.
Problematische Spanbildung, dadurch hohe Schnittkräfte und Verschleiß am Werkzeug und Bauteil.	Reduzierung des Schnittdrucks, höhere Standzeit und bessere Spanbildung.	Reduzierung des Schnittdrucks und bessere Spanbildung, aber einseitige Abnutzung des Werkzeugs.

Infeed possibilities

Radial infeed	alternating flank infeed	flank infeed
The most used method for threading. both sides are at the same time in process.	The flanks are alternating used.	Only one cutting edge is used for the complete thread.
Problematic chip forming, high cutting force and weariness at insert and work piece.	Reduced cutting force, higher tool life and chip forming.	Reduced cutting force and better chip forming, but one-sided weariness.

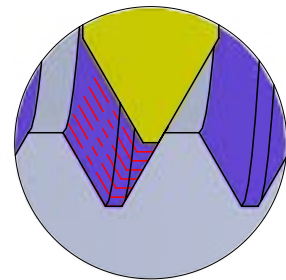
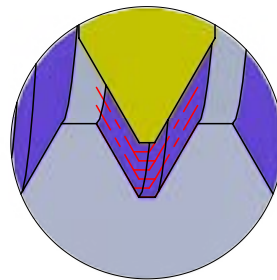
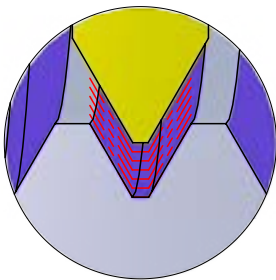

ULTRAMINI

Bohrungsbearbeitung
ab \varnothing 0.2 mm

grooving, boring and profiling
starting at \varnothing 0.2 mm

Technische Hinweise

Informationen zur Kühlung
von Typ Hardline und Typ 050.../CBN

Technical instructions,
cooling informations about type
Hardline and type 050.../CBN

Informationen zur Kühlung - Cooling informations



Typ 050 Hardline

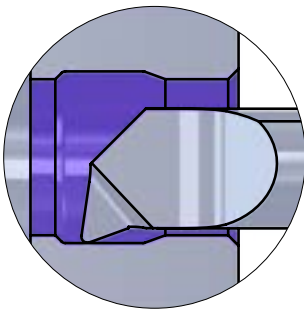

- **Achtung:**
Hardline-Schneiden müssen zwingend
mit Kühlung eingesetzt werden!!
- **Attention:** Hardline-inserts
must be used with cooling!!

Typ 050.../CBN

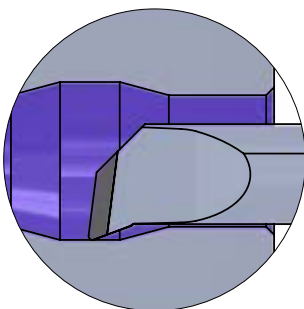

- **Achtung:**
CBN-Schneiden können ohne
Kühlung eingesetzt werden!!

Attention:
CBN-inserts could be used
without cooling!!



- **oder:**
Einsatz bei perfekter, gleichbleibender und
ununterbrochener Kühlbedingung!!

or:
Use with perfect, consistent and
uninterrupted cooling!!

ULTRAMINI

Bohrungsbearbeitung
ab \varnothing 0.2 mm

grooving, boring and profiling
starting at \varnothing 0.2 mm

Technische Hinweise

Hartmetallsorten und Beschichtungen

Technical instructions,
carbide grades and coatings

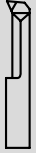

K10F

Universell einsetzbares Feinkornhartmetall mit guter Verschleißfestigkeit. Unbeschichtet geeignet für Anwendungen mit niedrigen und mittleren Schnittgeschwindigkeiten, sowie die Bearbeitung von NE-Metallen.

All purpose micrograin carbide with good abrasion resistance. Uncoated for applications with low or medium cutting speeds and machining of non-ferrous materials.

P04C

Optimierte, sehr universell einsetzbare TIALN-Beschichtung mit hoher Temperaturbeständigkeit bei hoher Härte. Sehr gut geeignet auch für NE-Metalle.

Optimized TIALN coating - very universal with a high resistance to high temperature and hardness. Very suitable also for non-ferrous metals.

AL41F

Sehr universell einsetzbare TIALN-Beschichtung mit hoher Temperaturbeständigkeit bei hoher Härte. Sehr gut geeignet auch für NE-Metalle.

TIALN coating - very universal with a high resistance to high temperature and hardness. Very suitable also for non-ferrous metals.

CN45F

Universell einsetzbare PVD-TIN-Beschichtung. Diese Allround-Sorte ist für niedrige und mittlere Schnittgeschwindigkeiten mit Einschränkung bei NE-Metallen.

PVD-TIN coating - all purpose, all around grade is suitable for low and medium cutting speed with restrictions on non-ferrous materials.

P18C

Universell einsetzbare Hochleistungsschicht mit hoher Oxidationsbeständigkeit, Verschleißfestigkeit und Warmhärte.

Very universal high performance coating with high oxidation resistance, wear resistance and hot hardness resistance.

P07C

Beschichtung für die Bearbeitung von Titan, Edelstahl und Molybdän.

Coating to machine titanium, stainless steel and molybdenum.

ULTRAMINI

Bohrungsbearbeitung
ab \varnothing 0.2 mm

grooving, boring and profiling
starting at \varnothing 0.2 mm

Technische Hinweise

Hartmetallsorten und Beschichtungen

Technical instructions,
carbide grades and coatings



XC2A

Beschichtung mit einer exzellenten Warmhärte, Oxidationsbeständigkeit und thermischen Isolationsfähigkeit. Ideal für Hartzerspanung >60HRC

Coating with excellent hot hardness, high oxidation resistance and thermal insulation capacity. Ideal for hard machining >60 HRC.

P03C

Beschichtung für die Bearbeitung von schwer zerspanbaren Materialien. Sehr gut auch für die Trockenbearbeitung geeignet.

Coating for materials which are difficult to machine. Perfect to use for dry machining.

PD2F

Beschichtung für den universellen Einsatz bei niedrigen und mittleren Schnittgeschwindigkeiten.

Coating for universal use with medium and low speed.

NEME

Beschichtung für die Bearbeitung von Aluminium, Al-Legierungen, NE-Metallen und Kompositwerkstoffen.

Coating for machining aluminium, Al alloys, non-ferrous metals and composite materials.

CBN

Zähe CBN-Sorte für Anwendungen mit niedrigen Schnittgeschwindigkeiten. Geeignet für gehärtete Stähle, unterbrochene Schnitte und Grauguss.

Ductile CBN grade for applications with lower cutting speed. Suitable for hardened steel, interrupted cuts and cast iron.

ULTRAMINI

Bohrungsbearbeitung
ab \varnothing 0.2 mm

grooving, boring and profiling
starting at \varnothing 0.2 mm

Impressionen

impressions

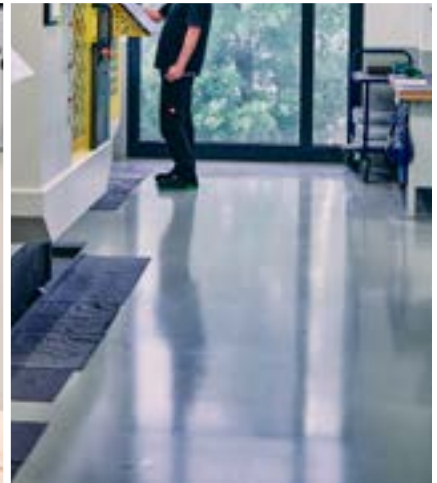
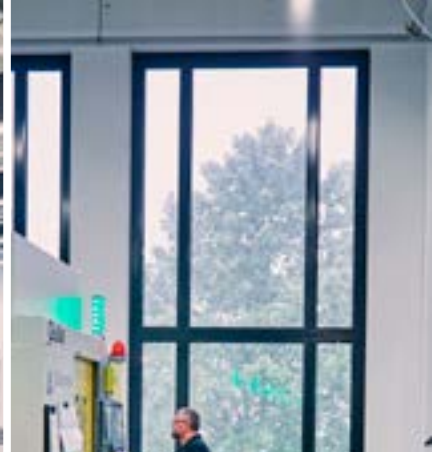
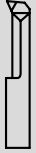

ULTRAMINI

Bohrungsbearbeitung
ab \varnothing 0.2 mm

grooving, boring and profiling
starting at \varnothing 0.2 mm

Technische Hinweise

Allgemeine Informationen über
Schnitttiefe und Vorschub für Typ DT

General instructions about
cutting depth and feed of type DT

Schnitttiefe und Vorschub für Typ DT

Cutting depth and feed of type DT



		Bohren / drilling							
Typ DT Größe / size		Vorschub f in mm/U / feed f in mm/Rev.							
R/ DT.2-	8	0.002 - 0.008							
R/L DT.3-	10	0.0025 - 0.0125							
	13	0.0025 - 0.010							
R/L DT.4-	15	0.005 - 0.030							
	20	0.005 - 0.015							
R/L DT.5-	15	0.005 - 0.040							
	25	0.005 - 0.020							
R/L DT.6-	15	0.005 - 0.030							
	30	0.005 - 0.020							
R/L DT.7-	20	0.005 - 0.035							
	35	0.005 - 0.025							
R/L DT.8-	25	0.005 - 0.040							
	40	0.005 - 0.030							

		Ausdrehen / boring									
Typ DT Größe / size		Spantiefe a_p in mm / cutting depth a_p in mm									
		0.2	0.5	1.0	1.5	2.0	2.5	3.0	3.5	4.0	
		Vorschub f in mm/U / feed f in mm/Rev.									
R/ DT.2-	8	0.01 - 0.04	0.01 - 0.02	(0.003-0.006)							
R/L DT.3-	10	0.02 - 0.07	0.02 - 0.07	0.02 - 0.05	0.005 - 0.01						
	13	0.02 - 0.05	0.02 - 0.05	0.005 - 0.03	0.005 - 0.01						
R/L DT.4-	15	0.04 - 0.1	0.04 - 0.1	0.04 - 0.1	0.03 - 0.07	0.01 - 0.05					
	20	0.04 - 0.1	0.04 - 0.1	0.03 - 0.08	0.01 - 0.05	0.005 - 0.025					
R/L DT.5-	15	0.04 - 0.1	0.04 - 0.1	0.04 - 0.1	0.03 - 0.08	0.02 - 0.06	0.01 - 0.04				
	25	0.04 - 0.1	0.04 - 0.1	0.03 - 0.09	0.02 - 0.06	0.01 - 0.04	0.005 - 0.025				
R/L DT.6-	15	0.04 - 0.1	0.04 - 0.1	0.04 - 0.1	0.04 - 0.1	0.03 - 0.08	0.02 - 0.06	0.01 - 0.04			
	30	0.04 - 0.1	0.04 - 0.1	0.03 - 0.09	0.02 - 0.06	0.01 - 0.04	0.01 - 0.03	0.005 - 0.03			
R/L DT.7-	20	0.04 - 0.1	0.04 - 0.1	0.04 - 0.1	0.04 - 0.1	0.04 - 0.1	0.04 - 0.1	0.03 - 0.08	0.02 - 0.06	0.01 - 0.04	
	35	0.04 - 0.1	0.04 - 0.1	0.04 - 0.1	0.03 - 0.08	0.02 - 0.06	0.01 - 0.04	0.01 - 0.03	0.01 - 0.02		
R/L DT.8-	25	0.04 - 0.1	0.04 - 0.1	0.04 - 0.1	0.04 - 0.1	0.04 - 0.1	0.04 - 0.1	0.04 - 0.1	0.03 - 0.08	0.02 - 0.06	0.01 - 0.04
	40	0.04 - 0.1	0.04 - 0.1	0.04 - 0.1	0.04 - 0.095	0.03 - 0.08	0.02 - 0.06	0.01 - 0.04	0.01 - 0.03	0.01 - 0.02	

- f - Werte sind IK - Druck abhängig: - IK - Druck 10 - 30 bar → unterer Bereich der f - Werte auswählen
- IK - Druck 30 - 70 bar → obere Bereich der f - Werte auswählen

- außerdem sind die f - Werte materialabhängig

- f - measures are depending on cooling pressure: - cooling pressure 10 - 30 bar → choose lower range of f - measures
- cooling pressure 30 - 70 bar → choose upper range of f - measures

- furthermore f - measures are depending on material

ULTRAMINI

Bohrungsbearbeitung
ab Ø 0.2 mm

grooving, boring and profiling
starting at Ø 0.2 mm

Technische Hinweise

Schnittdatenempfehlung:
metrisch

Schnittgeschwindigkeit: V_c (m/min)
Vorschub: f (mm/U)

Technical instructions,
speed and feed recommendation:
metric

cutting speed: V_c (m/min)
feed: f (mm/rev)

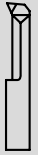

Werkstoffgruppe material group		Zusammensetzung composition		(Zug-)Festigkeit tensile strength
ISO	Beschreibung / description	Gefüge / structure	Wärmebehandlung / heat treatment	Psi / N/mm ² (Rm) / HB / HRC
P	Unlegierter Stahl unalloyed steel	ca.Japp. 0,15 % C	geglüht / annealed	61000 Psi / 420 N/mm ² / 125 HB
		ca.Japp. 0,45 % C	geglüht / annealed	93000 Psi / 640 N/mm ² / 190 HB
			vergütet / tempered	122000 Psi / 840 N/mm ² / 250 HB
		ca.Japp. 0,75 % C	geglüht / annealed	132000 Psi / 910 N/mm ² / 270 HB
	Niedriglegierter Stahl low alloyed steel		vergütet / tempered	146500 Psi / 1010 N/mm ² / 300 HB
			geglüht / annealed	88500 Psi / 610 N/mm ² / 180 HB
			vergütet / tempered	135000 Psi / 930 N/mm ² / 275 HB
			vergütet / tempered	146500 Psi / 1010 N/mm ² / 300 HB
			vergütet / tempered	174000 Psi / 1200 N/mm ² / 375 HB
			geglüht / annealed	99000 Psi / 680 N/mm ² / 200 HB
Hochlegierter (Werkzeug)-Stahl highly alloyed steel		gehärtet & angelassen / hardened & tempered	160000 Psi / 1100 N/mm ² / 300 HB	
		gehärtet & angelassen / hardened & tempered	189000 Psi / 1300 N/mm ² / 400 HB	
Nichtrostender Stahl stainless steel		ferritisch, martensitisch / ferritic, martensitic	geglüht / annealed	99000 Psi / 680 N/mm ² / 200 HB
		martensitisch / martensitic	vergütet / tempered	117500 Psi / 810 N/mm ² / 250 HB
M	Nichtrostender Stahl stainless steel	austenitisch / austenitic	abgeschreckt / quenched	88500 Psi / 610 N/mm ² / 200 HB
		austenitisch / austenitic	vergütet / tempered	300 HB
		austenitisch, ferritisch / ferritic, martensitic (Duplex)		113000 Psi / 780 N/mm ² / 230 HB
K	Grauguss cast iron	perlitisch, ferritisch / pearlitic, ferritic		51000 Psi / 350 N/mm ² / 180 HB
		perlitisch (martensitisch) / pearlitic (martensitic)		72500 Psi / 500 N/mm ² / 260 HB
K	Gusseisen mit Kugelgraphit cast iron with nodular graphite	ferritisch / ferritic		72500 Psi / 500 N/mm ² / 160 HB
		perlitisch / pearlitic		122500 Psi / 845 N/mm ² / 250 HB
	Temperguss malleable iron	ferritisch / ferritic		63800 Psi / 440 N/mm ² / 130 HB
		perlitisch / pearlitic		113000 Psi / 780 N/mm ² / 230 HB
N	Aluminium - Knetlegierungen wrought aluminum alloys	nicht aushärtbar / uncurable		60 HB
		aushärtbar / curable	ausgehärtet / cured	49000 Psi / 340 N/mm ² / 100 HB
		≤ 12% Si, nicht aushärtbar / uncurable		36250 Psi / 250 N/mm ² / 75 HB
	Aluminium - Gusslegierungen cast aluminum alloys	≤ 12% Si, aushärtbar / curable	ausgehärtet / cured	43500 Psi / 300 N/mm ² / 90 HB
		> 12% Si, nicht aushärtbar / uncurable		63800 Psi / 440 N/mm ² / 130 HB
				54500 Psi / 375 N/mm ² / 110 HB
Kupfer und Kupferlegierungen (Bronze / Messing) copper and copper alloys (bronze / brass)	PB > 1 %, Automatenlegierungen / free cutting alloys		54500 Psi / 375 N/mm ² / 110 HB	
	CuZn, CuSnZn		43500 Psi / 300 N/mm ² / 90 HB	
	CuSn, bleifrei & Elektrolytisch / lead free & electrolytic		49000 Psi / 340 N/mm ² / 100 HB	
Magnesium &-Legierungen / Mg-alloys	Magnesium und -Legierungen / and -alloys		70 HB	
S	Warmfeste Legierungen heat-resistant alloys	Fe-Basis / Fe base	geglüht / annealed	99000 Psi / 680 N/mm ² / 200 HB
			ausgehärtet / cured	137750 Psi / 950 N/mm ² / 280 HB
		Ni- oder Co-Basis / Ni- or Co-Base	geglüht / annealed	122000 Psi / 840 N/mm ² / 250 HB
			ausgehärtet / cured	171000 Psi / 1180 N/mm ² / 350 HB
			gegossen / cast	156600 Psi / 1080 N/mm ² / 320 HB
	Titanlegierungen titanium alloys	Reintitan / pure titanium		58000 Psi / 400 N/mm ²
		Alpha- + Beta-Legierungen / -alloys	ausgehärtet / cured	152250 Psi / 1050 N/mm ²
	Beta-Legierungen / -alloys		203000 Psi / 1400 N/mm ² / 410 HB	
H	Gehärteter Stahl hardened steel		gehärtet & angelassen / hardened & tempered	46-55 HRC
			gehärtet & angelassen / hardened & tempered	56-60 HRC
			gehärtet & angelassen / hardened & tempered	61-65 HRC
			gehärtet & angelassen / hardened & tempered	66-70 HRC
	Hartguss / chilled cast iron		gegossen / cast	400 HB
Gehärtetes Guss / hardened cast iron		gehärtet & angelassen / hardened & tempered	55 HRC	
O	Nichtmetallische Werkstoffe non-metallic materials	Kunststoffe, duroplastisch / plastics, duroplastic		≤ 21750 Psi / ≤ 150 N/mm ²
		Kunststoffe, thermoplastisch / plastics, thermoplastic		≤ 14500 Psi / ≤ 100 N/mm ²
		aramidfaserverstärkt / aramid fiber reinforced		≤ 145000 Psi / ≤ 1000 N/mm ²
		glas/kohlefaserverstärkt / glas/carbon fiber reinforced		≤ 145000 Psi / ≤ 1000 N/mm ²
		Graphit / graphite		

Richtige Schnittgeschwindigkeit ist in Abhängigkeit von Dimension und Anwendungssituation zu wählen.
The correct cutting speed must be selected depending on the dimension and application situation.

20 (10 - 50) bevorzugte Wahl / best choice
20 (10 - 50) bedingt möglich / conditionally possible

20 (10 - 50) empfohlener Startwert recommended starting value (bevorzugter Einsatzbereich) (preferred application area)

Vorschub: feed f: [mm/U] [mm/rev]

Stechdrehen: grooving: 0.01 - 0.03 mm/U
0.01 - 0.03 mm/rev

Ausdrehen / Kopieren: boring / profiling: 0.02 - 0.10 mm/U
0.02 - 0.10 mm/rev

Axialstechen: face grooving: 0.02 - 0.06 mm/U
0.02 - 0.06 mm/rev

ULTRAMINI

Bohrungsbearbeitung
ab Ø 0.2 mm

grooving, boring and profiling
starting at Ø 0.2 mm

Technische Hinweise

Schnittdatenempfehlung:
metrisch

Technical instructions,
speed and feed recommendation:
metric

Schnittgeschwindigkeit: V_c (m/min)
Vorschub: f (mm/U)

cutting speed: V_c (m/min)
feed: f (mm/rev)



beispielhafte Werkstoffe exemplary materials

DIN	DIN-Code	DIN	DIN-Code	V_c Start (min. - max.)					
				P04C / AL41F [m/min]	CN45F [m/min]	P18C [m/min]	P07C [m/min]	XC2A-NH [m/min]	CBN [m/min]
1.0401	C15	1.1141	Ck 15	110 (40 - 260)	90 (30 - 220)	110 (40 - 260)	110 (40 - 260)	110 (40 - 260)	
1.1191	C45E	1.0718	9 SMnPb 28	100 (30 - 230)	80 (30 - 190)	100 (30 - 230)	100 (30 - 230)	100 (30 - 230)	
1.1191	C45E	1.0535	C 55	80 (30 - 180)	60 (20 - 150)	80 (30 - 180)	80 (30 - 180)	80 (30 - 180)	
1.1223	C60R	1.0535	C 55	80 (30 - 180)	60 (20 - 150)	80 (30 - 180)	80 (30 - 180)	80 (30 - 180)	
1.1223	C60R	1.0727	45 S 20	60 (20 - 150)	60 (20 - 130)	60 (20 - 150)	60 (20 - 150)	60 (20 - 150)	
1.7131	16 MnCr 5	1.6587	17 CrNiMo6	80 (30 - 180)	60 (20 - 150)	80 (30 - 180)	80 (30 - 180)	80 (30 - 180)	
1.7131	16 MnCr 5	1.6587	17 CrNiMo6	60 (20 - 150)	60 (20 - 130)	60 (20 - 150)	60 (20 - 150)	60 (20 - 150)	
1.7225	42 CrMo 4	1.3505	100Cr6	60 (20 - 140)	50 (20 - 120)	60 (20 - 140)	60 (20 - 140)	60 (20 - 140)	
1.7225	42 CrMo 4	1.3505	100Cr6	60 (20 - 130)	50 (20 - 110)	60 (20 - 130)	60 (20 - 130)	60 (20 - 130)	
1.4021	X20Cr13	1.4034	X46Cr13	60 (20 - 130)	50 (20 - 110)	60 (20 - 130)	60 (20 - 130)	60 (20 - 130)	
1.2343	X 38 CrMoV 5 1	1.4034	X46Cr13	50 (20 - 100)	30 (10 - 80)	50 (20 - 100)	50 (20 - 100)	50 (20 - 100)	
1.2343	X 38 CrMoV 5 1	1.4034	X46Cr13	30 (10 - 80)	30 (10 - 60)	30 (10 - 80)	30 (10 - 80)	30 (10 - 80)	
1.4016	X 6 Cr 17	1.2316	X36 CrMo 16	70 (20 - 160)	60 (20 - 130)	70 (20 - 160)	70 (20 - 160)	70 (20 - 160)	
1.4112	X90CrMoV18	1.2316	X36 CrMo 16	60 (20 - 140)	50 (20 - 120)	60 (20 - 140)	60 (20 - 140)	60 (20 - 140)	
1.4301	X 5 CrNi 18 10	1.4571	X2CrNiMo17-12-2	80 (30 - 180)	60 (20 - 150)	80 (30 - 180)	80 (30 - 180)	80 (30 - 180)	
1.4841	X15CrNiSi25-21	1.4539	X1NiCrMoCu25-20-5	60 (20 - 140)	50 (20 - 120)	60 (20 - 140)	60 (20 - 140)	60 (20 - 140)	
1.4462	X2CrNiMoN22-5-3	1.4501	X2CrNiMoCuWN25-7-4	50 (20 - 110)	40 (10 - 90)	50 (20 - 110)	50 (20 - 110)	50 (20 - 110)	
0.6010	GG-10	0.6025	GG-25	100 (30 - 230)	80 (30 - 190)	100 (30 - 230)	100 (30 - 230)	100 (30 - 230)	
0.6030	GG-30	0.6045	GG-45	70 (20 - 160)	60 (20 - 140)	70 (20 - 160)	70 (20 - 160)	70 (20 - 160)	
0.7040	GGG-40	0.7060	GGG-60	60 (20 - 150)	60 (20 - 130)	60 (20 - 150)	60 (20 - 150)	60 (20 - 150)	
0.7070	GGG-70	0.7080	GGG-80	60 (20 - 130)	50 (20 - 110)	60 (20 - 130)	60 (20 - 130)	60 (20 - 130)	
0.8035	GTW-35-04	0.8045	GTW-45	100 (30 - 230)	80 (30 - 190)	100 (30 - 230)	100 (30 - 230)	100 (30 - 230)	
0.8165	GTS-65-02	0.8170	GTS-70-02	80 (30 - 190)	70 (20 - 160)	80 (30 - 190)	80 (30 - 190)	80 (30 - 190)	
3.0255	Al99,5	3.3315	AlMg 1	230 (80 - 540)	200 (70 - 450)	230 (80 - 540)	230 (80 - 540)	230 (80 - 540)	
3.1355	AlCuMg2	3.2315	AlMgSi1	220 (80 - 510)	180 (60 - 430)	220 (80 - 510)	220 (80 - 510)	220 (80 - 510)	
3.2581	G-AlSi12	3.2163	G-AlSi9Cu3	190 (70 - 440)	160 (50 - 370)	190 (70 - 440)	190 (70 - 440)	190 (70 - 440)	
3.2134	G-AlSi5Cu1Mg	3.2373	G-AlSi9Mg	170 (60 - 380)	140 (50 - 320)	170 (60 - 380)	170 (60 - 380)	170 (60 - 380)	
-	G-AlSi17Cu4Mg (Silafont-90)	-	G-AlSi18CuNiMg (Silafont-92)	100 (30 - 230)	80 (30 - 190)	100 (30 - 230)	100 (30 - 230)	100 (30 - 230)	
2.0380	CuZn39Pb2 (Ms58)	2.0410	CuZn44Pb2	170 (60 - 390)	140 (50 - 330)	170 (60 - 390)	170 (60 - 390)	170 (60 - 390)	
2.0331	CuZn15	2.4070	CuZn28Sn1As	140 (50 - 330)	120 (40 - 270)	140 (50 - 330)	140 (50 - 330)	140 (50 - 330)	
2.0060	E-Cu57	2.0590	CuZn40Fe	120 (40 - 290)	100 (30 - 240)	120 (40 - 290)	120 (40 - 290)	120 (40 - 290)	
3.5612	MgAl6Zn	3.5312	MgAl3Zn	120 (40 - 290)	100 (30 - 240)	120 (40 - 290)	120 (40 - 290)	120 (40 - 290)	
1.4864	X12NiCrSi 36-16	1.4865	G-X40NiCrSi38-18	50 (20 - 100)	30 (10 - 80)	50 (20 - 100)	50 (20 - 100)	50 (20 - 100)	
1.4980	X6NiCrTiMoVB25-15-2	1.4876	X10NiCrAlTi32-20	30 (10 - 70)	30 (10 - 60)	30 (10 - 70)	30 (10 - 70)	30 (10 - 70)	30 (10 - 70)
2.4631	NiCr20TiAl (Nimonic 80A)	2.4856	NiCr22Mo9Nb (Inconel 625)	50 (20 - 100)	30 (10 - 80)	50 (20 - 100)	50 (20 - 100)	50 (20 - 100)	50 (20 - 100)
2.4668	NiCr19Nb5Mo3 (Inconel 718)	2.4955	NiFe25Cr20NbTi	30 (10 - 80)	30 (10 - 70)	30 (10 - 80)	30 (10 - 80)	30 (10 - 80)	30 (10 - 80)
2.4765	CoCr20W15Ni	1.3401	G-X120Mn12	30 (10 - 60)	30 (10 - 60)	30 (10 - 60)	30 (10 - 60)	30 (10 - 60)	30 (10 - 60)
3.7025	Ti99,8	3.7035	Ti99,7	50 (20 - 100)	30 (10 - 80)	50 (20 - 100)	50 (20 - 100)	50 (20 - 100)	
3.7164	TiAl6V4	Ti-6246	Ti-6Al-2Sn-4Zr-6Mo	30 (10 - 60)	20 (10 - 50)	30 (10 - 60)	30 (10 - 60)	30 (10 - 60)	
Ti5553	Ti-5Al-5V-5Mo-3Cr	Ti-1023	Ti-10V-2Fe-3Al	20 (10 - 50)		20 (10 - 50)	20 (10 - 50)	20 (10 - 50)	20 (10 - 50)
				40 (10 - 90)	30 (10 - 60)	40 (10 - 90)	40 (10 - 90)	40 (10 - 90)	40 (10 - 90)
				30 (10 - 80)		30 (10 - 80)	30 (10 - 60)	30 (10 - 80)	30 (10 - 80)
							20 (10 - 50)	30 (10 - 60)	30 (10 - 60)
						30 (10 - 80)			
				30 (10 - 60)	20 (10 - 50)	30 (10 - 60)	30 (10 - 60)	30 (10 - 60)	30 (10 - 60)
				110 (40 - 260)	90 (30 - 220)	110 (40 - 260)	110 (40 - 260)	110 (40 - 260)	
				120 (40 - 290)	100 (30 - 240)	120 (40 - 290)	120 (40 - 290)	120 (40 - 290)	
				110 (40 - 240)	90 (30 - 200)	110 (40 - 240)	110 (40 - 240)	110 (40 - 240)	
				80 (30 - 180)	60 (20 - 150)	80 (30 - 180)	80 (30 - 180)	80 (30 - 180)	
				120 (40 - 280)	100 (30 - 230)	120 (40 - 280)	120 (40 - 280)	120 (40 - 280)	

Richtige Schnittgeschwindigkeit ist in Abhängigkeit von Dimension und Anwendungssituation zu wählen.
The correct cutting speed must be selected depending on the dimension and application situation.

20 (10 - 50) bevorzugte Wahl / best choice
20 (10 - 50) bedingt möglich / conditionally possible

20 (10 - 50) empfohlener Startwert recommended starting value (bevorzugter Einsatzbereich) (preferred application area)

Vorschub: feed f: [mm/U] [mm/rev]

Stechdrehen: grooving: 0.01 - 0.03 mm/U
0.01 - 0.03 mm/rev

Ausdrehen / Kopieren: boring / profiling: 0.02 - 0.10 mm/U
0.02 - 0.10 mm/rev

Axialstechen: face grooving: 0.02 - 0.06 mm/U
0.02 - 0.06 mm/rev

ULTRAMINI

Bohrungsbearbeitung
ab Ø 0.2 mm

grooving, boring and profiling
starting at Ø 0.2 mm

Technische Hinweise

Schnittdatenempfehlung:

Technical instructions,
speed and feed recommendation:
imperial

cutting speed (SFM): V_c (feet/min)
feed: f (inch/rev)

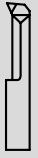

Werkstoffgruppe material group		Zusammensetzung composition		(Zug-)Festigkeit tensile strength	
ISO	Beschreibung / description	Gefüge / structure	Wärmebehandlung / heat treatment	Psi / N/mm ² (Rm) / HB / HRC	
P	Unlegierter Stahl unalloyed steel	ca.lapp. 0,15 % C	geglüht / annealed	61000 Psi / 420 N/mm ² / 125 HB	
		ca.lapp. 0,45 % C	geglüht / annealed	93000 Psi / 640 N/mm ² / 190 HB	
			vergütet / tempered	122000 Psi / 840 N/mm ² / 250 HB	
		ca.lapp. 0,75 % C	geglüht / annealed	132000 Psi / 910 N/mm ² / 270 HB	
	Niedriglegierter Stahl low alloyed steel			vergütet / tempered	146500 Psi / 1010 N/mm ² / 300 HB
				geglüht / annealed	88500 Psi / 610 N/mm ² / 180 HB
				vergütet / tempered	135000 Psi / 930 N/mm ² / 275 HB
				vergütet / tempered	146500 Psi / 1010 N/mm ² / 300 HB
				vergütet / tempered	174000 Psi / 1200 N/mm ² / 375 HB
				geglüht / annealed	99000 Psi / 680 N/mm ² / 200 HB
Hochlegierter (Werkzeug)-Stahl highly alloyed steel			gehärtet & angelassen / hardened & tempered	160000 Psi / 1100 N/mm ² / 300 HB	
			gehärtet & angelassen / hardened & tempered	189000 Psi / 1300 N/mm ² / 400 HB	
Nichtrostender Stahl stainless steel		ferritisch, martensitisch / ferritic, martensitic	geglüht / annealed	99000 Psi / 680 N/mm ² / 200 HB	
		martensitisch / martensitic	vergütet / tempered	117500 Psi / 810 N/mm ² / 250 HB	
M	Nichtrostender Stahl stainless steel	austenitisch / austenitic	abgeschreckt / quenched	88500 Psi / 610 N/mm ² / 200 HB	
		austenitisch / austenitic	vergütet / tempered	300 HB	
		austenitisch, ferritisch / ferritic, martensitic (Duplex)		113000 Psi / 780 N/mm ² / 230 HB	
K	Grauguss cast iron	perlitisches, ferritisch / pearlitic, ferritic		51000 Psi / 350 N/mm ² / 180 HB	
		perlitisches (martensitisch) / pearlitic (martensitic)		72500 Psi / 500 N/mm ² / 260 HB	
	Gusseisen mit Kugelgraphit cast iron with nodular graphite	ferritisch / ferritic		72500 Psi / 500 N/mm ² / 160 HB	
		perlitisches / pearlitic		122500 Psi / 845 N/mm ² / 250 HB	
Temperguss malleable iron	ferritisch / ferritic		63800 Psi / 440 N/mm ² / 130 HB		
	perlitisches / pearlitic		113000 Psi / 780 N/mm ² / 230 HB		
N	Aluminium - Knetlegierungen wrought aluminum alloys	nicht aushärtbar / uncurable		60 HB	
		aushärtbar / curable	ausgehärtet / cured	49000 Psi / 340 N/mm ² / 100 HB	
	Aluminium - Gusslegierungen cast aluminum alloys	≤ 12% Si, nicht aushärtbar / uncurable		36250 Psi / 250 N/mm ² / 75 HB	
		≤ 12% Si, aushärtbar / curable	ausgehärtet / cured	43500 Psi / 300 N/mm ² / 90 HB	
		> 12% Si, nicht aushärtbar / uncurable		63800 Psi / 440 N/mm ² / 130 HB	
				54500 Psi / 375 N/mm ² / 110 HB	
Kupfer und Kupferlegierungen (Bronze / Messing) copper and copper alloys (bronze / brass)	PB > 1 %, Automatenlegierungen / free cutting alloys		43500 Psi / 300 N/mm ² / 90 HB		
	CuZn, CuSnZn		43500 Psi / 300 N/mm ² / 90 HB		
	CuSn, bleifrei & Elektrolytisch / lead free & electrolytic		49000 Psi / 340 N/mm ² / 100 HB		
Magnesium & -Legierungen / Mg-alloys	Magnesium und -Legierungen / and -alloys		70 HB		
S	Warmfeste Legierungen heat-resistant alloys	Fe-Basis / Fe base	geglüht / annealed	99000 Psi / 680 N/mm ² / 200 HB	
			ausgehärtet / cured	137750 Psi / 950 N/mm ² / 280 HB	
		Ni- oder Co-Basis / Ni- or Co-Base	geglüht / annealed	122000 Psi / 840 N/mm ² / 250 HB	
			ausgehärtet / cured	171000 Psi / 1180 N/mm ² / 350 HB	
			gegossen / cast	156600 Psi / 1080 N/mm ² / 320 HB	
	Titanlegierungen titanium alloys	Reintitan / pure titanium		58000 Psi / 400 N/mm ²	
		Alpha- + Beta-Legierungen / -alloys	ausgehärtet / cured	152250 Psi / 1050 N/mm ²	
H	Gehärteter Stahl hardened steel		gehärtet & angelassen / hardened & tempered	46-55 HRC	
			gehärtet & angelassen / hardened & tempered	56-60 HRC	
			gehärtet & angelassen / hardened & tempered	61-65 HRC	
			gehärtet & angelassen / hardened & tempered	66-70 HRC	
	Hartguss / chilled cast iron		gegossen / cast	400 HB	
Gehärtetes Guss / hardened cast iron		gehärtet & angelassen / hardened & tempered	55 HRC		
O	Nichtmetallische Werkstoffe non-metallic materials	Kunststoffe, duroplastisch / plastics, duroplastic		≤ 21750 Psi / ≤ 150 N/mm ²	
		Kunststoffe, thermoplastisch / plastics, thermoplastic		≤ 14500 Psi / ≤ 100 N/mm ²	
		aramidfaserverstärkt / aramid fiber reinforced		≤ 145000 Psi / ≤ 1000 N/mm ²	
		glas/kohlefaserverstärkt / glas/carbon fiber reinforced		≤ 145000 Psi / ≤ 1000 N/mm ²	
		Graphit / graphite			

<p>The correct cutting speed must be selected depending on the dimension and application situation.</p>	<p>20 (10 - 50) best choice</p> <p>20 (10 - 50) conditionally possible</p>	<p>feed f: [inch/rev]</p> <p>grooving: 0.0004 - 0.0012 in/rev</p>
	<p>20 (10 - 50)</p> <p>recommended starting value (preferred application area)</p>	<p>boring / profiling: 0.0008 - 0.0039 in/rev</p>
		<p>face grooving: 0.0008 - 0.0024 in/rev</p>

ULTRAMINI

Bohrungsbearbeitung
ab Ø 0.2 mm

grooving, boring and profiling
starting at Ø 0.2 mm

Technische Hinweise

Schnittdatenempfehlung:

Technical instructions,
speed and feed recommendation:
imperial

cutting speed (SFM): V_c (feet/min)
feed: f (inch/rev)



beispielhafte Werkstoffe exemplary materials

				V_c Start (min. - max.)					
AISI	DIN-Code	AISI	DIN-Code	P04C / AL41F [SFM]	CN45F [SFM]	P18C [SFM]	P07C [SFM]	XC2A-NH [SFM]	CBN [SFM]
1015	C15	1015	Ck 15	360 (130 - 850)	300 (100 - 720)	360 (130 - 850)	360 (130 - 850)	360 (130 - 850)	
1045	C45E	12L13	9 SMnPb 28	330 (100 - 750)	260 (100 - 620)	330 (100 - 750)	330 (100 - 750)	330 (100 - 750)	
1045	C45E	1055	C 55	260 (100 - 590)	200 (70 - 490)	260 (100 - 590)	260 (100 - 590)	260 (100 - 590)	
1060	C60R	1055	C 55	260 (100 - 590)	200 (70 - 490)	260 (100 - 590)	260 (100 - 590)	260 (100 - 590)	
1060	C60R	1146	45 S 20	200 (70 - 490)	200 (70 - 430)	200 (70 - 490)	200 (70 - 490)	200 (70 - 490)	
5115	16 MnCr 5	4820	17 CrNiMo6	260 (100 - 590)	200 (70 - 490)	260 (100 - 590)	260 (100 - 590)	260 (100 - 590)	
5115	16 MnCr 5	4820	17 CrNiMo6	200 (70 - 490)	200 (70 - 430)	200 (70 - 490)	200 (70 - 490)	200 (70 - 490)	
4140	42 CrMo 4	E52100	100Cr6	200 (70 - 460)	160 (70 - 390)	200 (70 - 460)	200 (70 - 460)	200 (70 - 460)	
4140	42 CrMo 4	E52100	100Cr6	200 (70 - 430)	160 (70 - 360)	200 (70 - 430)	200 (70 - 430)	200 (70 - 430)	
420	X20Cr13	420	X46Cr13	200 (70 - 430)	160 (70 - 360)	200 (70 - 430)	200 (70 - 430)	200 (70 - 430)	
H11	X 38 CrMoV 5 1	420	X46Cr13	160 (70 - 330)	100 (30 - 260)	160 (70 - 330)	160 (70 - 330)	160 (70 - 330)	
H11	X 38 CrMoV 5 1	420	X46Cr13	100 (30 - 260)	100 (30 - 200)	100 (30 - 260)	100 (30 - 260)	100 (30 - 260)	
430/1	X 6 Cr 17	422	X36 CrMo 16	230 (70 - 520)	200 (70 - 430)	230 (70 - 520)	230 (70 - 520)	230 (70 - 520)	
440B	X90CrMoV18	422	X36 CrMo 16	200 (70 - 460)	160 (70 - 390)	200 (70 - 460)	200 (70 - 460)	200 (70 - 460)	
304	X 5 CrNi 18 10	316Ti	X2CrNiMo17-12-2	260 (100 - 590)	200 (70 - 490)	260 (100 - 590)	260 (100 - 590)	260 (100 - 590)	
314	X15CrNiSi25-21	904L	X1NiCrMoCu25-20-5	200 (70 - 460)	160 (70 - 390)	200 (70 - 460)	200 (70 - 460)	200 (70 - 460)	
318	X2CrNiMoN22-5-3	A790	X2CrNiMoCuWN25-7-4	160 (70 - 360)	130 (30 - 300)	160 (70 - 360)	160 (70 - 360)	160 (70 - 360)	
No 20B	GG-10	No 35B	GG-25	330 (100 - 750)	260 (100 - 620)	330 (100 - 750)	330 (100 - 750)	330 (100 - 750)	
No 45B	GG-30	-	GG-45	230 (70 - 520)	200 (70 - 460)	230 (70 - 520)	230 (70 - 520)	230 (70 - 520)	
60-40-18	GGG-40	80-55-06	GGG-60	200 (70 - 490)	200 (70 - 430)	200 (70 - 490)	200 (70 - 490)	200 (70 - 490)	
100-70-03	GGG-70	120-90-02	GGG-80	200 (70 - 430)	160 (70 - 360)	200 (70 - 430)	200 (70 - 430)	200 (70 - 430)	
-	GTW-35-04	-	GTW-45	330 (100 - 750)	260 (100 - 620)	330 (100 - 750)	330 (100 - 750)	330 (100 - 750)	
A220-70003	GTS-65-02	A220-80002	GTS-70-02	260 (100 - 620)	230 (70 - 520)	260 (100 - 620)	260 (100 - 620)	260 (100 - 620)	
A91060	Al99,5	5005A	AlMg 1	750 (260 - 1770)	660 (230 - 1480)	750 (260 - 1770)	750 (260 - 1770)	750 (260 - 1770)	
2024	AlCuMg2	6082	AlMgSi1	720 (260 - 1670)	590 (200 - 1410)	720 (260 - 1670)	720 (260 - 1670)	720 (260 - 1670)	
A04130	G-AlSi12	-	G-AlSi9Cu3	620 (230 - 1440)	520 (160 - 1210)	620 (230 - 1440)	620 (230 - 1440)	620 (230 - 1440)	
355.1	G-AlSi5Cu1Mg	-	G-AlSi9Mg	560 (200 - 1250)	460 (160 - 1050)	560 (200 - 1250)	560 (200 - 1250)	560 (200 - 1250)	
-	G-AlSi17Cu4Mg (Silafont-90)	-	G-AlSi18CuNiMg (Silafont-92)	330 (100 - 750)	260 (100 - 620)	330 (100 - 750)	330 (100 - 750)	330 (100 - 750)	
C37700	CuZn39Pb2 (Ms58)	C38500	CuZn44Pb2	560 (200 - 1280)	460 (160 - 1080)	560 (200 - 1280)	560 (200 - 1280)	560 (200 - 1280)	
C34000	CuZn15	-	CuZn28Sn1As	460 (160 - 1080)	390 (130 - 890)	460 (160 - 1080)	460 (160 - 1080)	460 (160 - 1080)	
C11000	E-Cu57	-	CuZn40Fe	390 (130 - 950)	330 (100 - 790)	390 (130 - 950)	390 (130 - 950)	390 (130 - 950)	
AZ61A	MgAl6Zn	AZ31B	MgAl3Zn	390 (130 - 950)	330 (100 - 790)	390 (130 - 950)	390 (130 - 950)	390 (130 - 950)	
330	X12NiCrSi 36-16	-	G-X40NiCrSi38-18	160 (70 - 330)	100 (30 - 260)	160 (70 - 330)	160 (70 - 330)	160 (70 - 330)	
A286	X6NiCrTiMoVB25-15-2	B163	X10NiCrAlTi32-20	100 (30 - 230)	100 (30 - 200)	100 (30 - 230)	100 (30 - 230)	100 (30 - 230)	100 (30 - 230)
-	NiCr20TiAl (Nimonic 80A)	SB443	NiCr22Mo9Nb (Inconel 625)	160 (70 - 330)	100 (30 - 260)	160 (70 - 330)	160 (70 - 330)	160 (70 - 330)	160 (70 - 330)
-	NiCr19Nb5Mo3 (Inconel 718)	-	NiFe25Cr20NbTi	100 (30 - 260)	100 (30 - 230)	100 (30 - 260)	100 (30 - 260)	100 (30 - 260)	100 (30 - 260)
-	CoCr20W15Ni	A 128 75	G-X120Mn12	100 (30 - 200)	100 (30 - 200)	100 (30 - 200)	100 (30 - 200)	100 (30 - 200)	100 (30 - 200)
R 50250	Ti99,8	R 50400	Ti99,7	160 (70 - 330)	100 (30 - 260)	160 (70 - 330)	160 (70 - 330)	160 (70 - 330)	
R 56400	TiAl6V4	R 56260	Ti-6Al-2Sn-4Zr-6Mo	100 (30 - 200)	70 (30 - 160)	100 (30 - 200)	100 (30 - 200)	100 (30 - 200)	
-	Ti-5Al-5V-5Mo-3Cr	R 56410	Ti-10V-2Fe-3Al	70 (30 - 160)		70 (30 - 160)	70 (30 - 160)	70 (30 - 160)	70 (30 - 160)
				130 (30 - 300)	100 (30 - 200)	130 (30 - 300)	130 (30 - 300)	130 (30 - 300)	130 (30 - 300)
				100 (30 - 260)		100 (30 - 260)	100 (30 - 200)	100 (30 - 260)	100 (30 - 260)
							70 (30 - 160)	100 (30 - 200)	100 (30 - 200)
				100 (30 - 200)	70 (30 - 160)	100 (30 - 200)	100 (30 - 200)	100 (30 - 200)	100 (30 - 200)
				360 (130 - 850)	300 (100 - 720)	360 (130 - 850)	360 (130 - 850)	360 (130 - 850)	
				390 (130 - 950)	330 (100 - 790)	390 (130 - 950)	390 (130 - 950)	390 (130 - 950)	
				360 (130 - 790)	300 (100 - 660)	360 (130 - 790)	360 (130 - 790)	360 (130 - 790)	
				260 (100 - 590)	200 (70 - 490)	260 (100 - 590)	260 (100 - 590)	260 (100 - 590)	
				390 (130 - 920)	330 (100 - 750)	390 (130 - 920)	390 (130 - 920)	390 (130 - 920)	

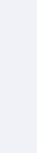
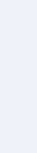
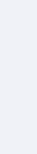
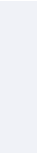

The correct cutting speed must be selected depending on the dimension and application situation.

20 (10 - 50) best choice
20 (10 - 50) conditionally possible

20 (10 - 50) recommended starting value (preferred application area)

feed f : [inch/rev]
grooving: 0.0004 - 0.0012 in/rev
boring / profiling: 0.0008 - 0.0039 in/rev
face grooving: 0.0008 - 0.0024 in/rev

TYP DT

Multifunktionswerkzeug zum Bohren und Ausdrehen

Multifunctional tool drilling and boring

Technische Hinweise

Schnittdatenempfehlung: metrisch

Schnittgeschwindigkeit: V_c (m/min)
Vorschub: f (mm/U)

Technical instructions, speed and feed recommendation: metric

cutting speed: V_c (m/min)
feed: f (mm/rev)

Typ DT

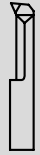
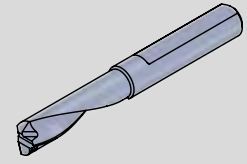

Werkstoffgruppe material group		Zusammensetzung composition		(Zug-)Festigkeit tensile strength
ISO	Beschreibung / description	Gefüge / structure	Wärmebehandlung / heat treatment	Psi / N/mm ² (Rm) / HB / HRC
P	Unlegierter Stahl unalloyed steel	ca.lapp. 0,15 % C	geglüht / annealed	61000 Psi / 420 N/mm ² / 125 HB
		ca.lapp. 0,45 % C	geglüht / annealed	93000 Psi / 640 N/mm ² / 190 HB
			vergütet / tempered	122000 Psi / 840 N/mm ² / 250 HB
		ca.lapp. 0,75 % C	geglüht / annealed	132000 Psi / 910 N/mm ² / 270 HB
			vergütet / tempered	146500 Psi / 1010 N/mm ² / 300 HB
	Niedriglegierter Stahl low alloyed steel		geglüht / annealed	88500 Psi / 610 N/mm ² / 180 HB
			vergütet / tempered	135000 Psi / 930 N/mm ² / 275 HB
			vergütet / tempered	146500 Psi / 1010 N/mm ² / 300 HB
			vergütet / tempered	174000 Psi / 1200 N/mm ² / 375 HB
	Hochlegierter (Werkzeug-)Stahl highly alloyed steel		geglüht / annealed	99000 Psi / 680 N/mm ² / 200 HB
		gehärtet & angelassen / hardened & tempered	160000 Psi / 1100 N/mm ² / 300 HB	
Nichtrostender Stahl stainless steel		gehärtet & angelassen / hardened & tempered	189000 Psi / 1300 N/mm ² / 400 HB	
		geglüht / annealed	99000 Psi / 680 N/mm ² / 200 HB	
M	Nichtrostender Stahl stainless steel	ferritisch, martensitisch / ferritic, martensitic	geglüht / annealed	99000 Psi / 680 N/mm ² / 200 HB
		martensitisch / martensitic	vergütet / tempered	117500 Psi / 810 N/mm ² / 250 HB
		austenitisch / austenitic	abgeschreckt / quenched	88500 Psi / 610 N/mm ² / 200 HB
K	Grauguss cast iron	austenitisch / austenitic	vergütet / tempered	300 HB
		austenitisch, ferritisch / ferritic, martensitic (Duplex)		113000 Psi / 780 N/mm ² / 230 HB
		perlitisch, ferritisch / pearlitic, ferritic		51000 Psi / 350 N/mm ² / 180 HB
K	Gusseisen mit Kugelgraphit cast iron with nodular graphite	perlitisch (martensitisch) / pearlitic (martensitic)		72500 Psi / 500 N/mm ² / 260 HB
		ferritisch / ferritic		72500 Psi / 500 N/mm ² / 160 HB
	Temperguss malleable iron	perlitisch / pearlitic		122500 Psi / 845 N/mm ² / 250 HB
		ferritisch / ferritic		63800 Psi / 440 N/mm ² / 130 HB
N	Aluminium - Knetlegierungen wrought aluminum alloys	nicht aushärtbar / uncurable		60 HB
		aushärtbar / curable	ausgehärtet / cured	49000 Psi / 340 N/mm ² / 100 HB
		≤ 12% Si, nicht aushärtbar / uncurable		36250 Psi / 250 N/mm ² / 75 HB
	Aluminium - Gusslegierungen cast aluminum alloys	≤ 12% Si, aushärtbar / curable	ausgehärtet / cured	43500 Psi / 300 N/mm ² / 90 HB
		> 12% Si, nicht aushärtbar / uncurable		63800 Psi / 440 N/mm ² / 130 HB
		PB > 1 %, Automatenlegierungen / free cutting alloys		54500 Psi / 375 N/mm ² / 110 HB
Kupfer und Kupferlegierungen (Bronze / Messing) copper and copper alloys (bronze / brass)	CuZn, CuSnZn		43500 Psi / 300 N/mm ² / 90 HB	
	CuSn, bleifrei & Elektrolitisch / lead free & electrolytic		49000 Psi / 340 N/mm ² / 100 HB	
Magnesium &-Legierungen / Mg-alloys	Magnesium und -Legierungen / and -alloys		70 HB	
S	Warmfeste Legierungen heat-resistant alloys	Fe-Basis / Fe base	geglüht / annealed	99000 Psi / 680 N/mm ² / 200 HB
			ausgehärtet / cured	137750 Psi / 950 N/mm ² / 280 HB
		Ni- oder Co-Basis / Ni- or Co-Base	geglüht / annealed	122000 Psi / 840 N/mm ² / 250 HB
			ausgehärtet / cured	171000 Psi / 1180 N/mm ² / 350 HB
			gegossen / cast	156600 Psi / 1080 N/mm ² / 320 HB
	Titanlegierungen titanium alloys	Reintitan / pure titanium		58000 Psi / 400 N/mm ²
		Alpha- + Beta-Legierungen / -alloys	ausgehärtet / cured	152250 Psi / 1050 N/mm ²
H	Gehärteter Stahl hardened steel		gehärtet & angelassen / hardened & tempered	46-55 HRC
			gehärtet & angelassen / hardened & tempered	56-60 HRC
			gehärtet & angelassen / hardened & tempered	61-65 HRC
			gehärtet & angelassen / hardened & tempered	66-70 HRC
	Hartguss / chilled cast iron		gegossen / cast	400 HB
Gehärtetes Guss / hardened cast iron		gehärtet & angelassen / hardened & tempered	55 HRC	
O	Nichtmetallische Werkstoffe non-metallic materials	Kunststoffe, duroplastisch / plastics, duroplastic		≤ 21750 Psi / ≤ 150 N/mm ²
		Kunststoffe, thermoplastisch / plastics, thermoplastic		≤ 14500 Psi / ≤ 100 N/mm ²
		aramidfaserverstärkt / aramid fiber reinforced		≤ 145000 Psi / ≤ 1000 N/mm ²
		glas/kohlefaserverstärkt / glas/carbon fiber reinforced		≤ 145000 Psi / ≤ 1000 N/mm ²
		Graphit / graphite		

Richtige Schnittgeschwindigkeit ist in Abhängigkeit von Dimension und Anwendungssituation zu wählen.

The correct cutting speed must be selected depending on the dimension and application situation.

20 (10 - 50) bevorzugte Wahl / best choice
20 (10 - 50) bedingt möglich / conditionally possible

20 (10 - 50) empfohlener Startwert recommended starting value (bevorzugter Einsatzbereich) (preferred application area)

weitere Informationen zu Vorschub und Schnitttiefe:
• siehe Technische Hinweise:
Allgemeine Informationen über Schnitttiefe und Vorschub Typ DT

more informations about feed and cutting depth:
• look at the technical instructions:
General instructions about cutting depth and feed type DT

TYP DT

Multifunktionswerkzeug zum Bohren und Ausdrehen

Multifunctional tool drilling and boring

Technische Hinweise

Schnittdatenempfehlung:

Technical instructions, speed and feed recommendation: imperial

cutting speed (SFM): V_c (feet/min)
feed: f (inch/rev)

Typ DT

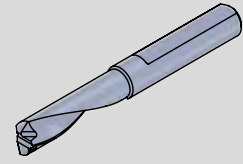

Werkstoffgruppe material group		Zusammensetzung composition		(Zug-)Festigkeit tensile strength	
ISO	Beschreibung / description	Gefüge / structure	Wärmebehandlung / heat treatment	Psi / N/mm ² (Rm) / HB / HRC	
P	Unlegierter Stahl unalloyed steel	ca.lapp. 0,15 % C	geglüht / annealed	61000 Psi / 420 N/mm ² / 125 HB	
		ca.lapp. 0,45 % C	geglüht / annealed	93000 Psi / 640 N/mm ² / 190 HB	
			vergütet / tempered	122000 Psi / 840 N/mm ² / 250 HB	
		ca.lapp. 0,75 % C	geglüht / annealed	132000 Psi / 910 N/mm ² / 270 HB	
			vergütet / tempered	146500 Psi / 1010 N/mm ² / 300 HB	
	Niedriglegierter Stahl low alloyed steel			geglüht / annealed	88500 Psi / 610 N/mm ² / 180 HB
				vergütet / tempered	135000 Psi / 930 N/mm ² / 275 HB
				vergütet / tempered	146500 Psi / 1010 N/mm ² / 300 HB
				vergütet / tempered	174000 Psi / 1200 N/mm ² / 375 HB
	Hochlegierter (Werkzeug-)Stahl highly alloyed steel			geglüht / annealed	99000 Psi / 680 N/mm ² / 200 HB
			gehärtet & angelassen / hardened & tempered	160000 Psi / 1100 N/mm ² / 300 HB	
Nichtrostender Stahl stainless steel			gehärtet & angelassen / hardened & tempered	189000 Psi / 1300 N/mm ² / 400 HB	
		ferritisch, martensitisch / ferritic, martensitic	geglüht / annealed	99000 Psi / 680 N/mm ² / 200 HB	
M	Nichtrostender Stahl stainless steel		martensitisch / martensitic	vergütet / tempered	117500 Psi / 810 N/mm ² / 250 HB
			austenitisch / austenitic	abgeschreckt / quenched	88500 Psi / 610 N/mm ² / 200 HB
			austenitisch / austenitic	vergütet / tempered	300 HB
K	Grauguss cast iron		austenitisch, ferritisch / ferritic, martensitic (Duplex)	113000 Psi / 780 N/mm ² / 230 HB	
			perlitisch, ferritisch / pearlitic, ferritic	51000 Psi / 350 N/mm ² / 180 HB	
	Gusseisen mit Kugelgraphit cast iron with nodular graphite		perlitisch (martensitisch) / pearlitic (martensitic)	72500 Psi / 500 N/mm ² / 260 HB	
			ferritisch / ferritic	72500 Psi / 500 N/mm ² / 160 HB	
			perlitisch / pearlitic	122500 Psi / 845 N/mm ² / 250 HB	
Temperguss malleable iron		ferritisch / ferritic	63800 Psi / 440 N/mm ² / 130 HB		
		perlitisch / pearlitic	113000 Psi / 780 N/mm ² / 230 HB		
N	Aluminium - Knetlegierungen wrought aluminum alloys		nicht aushärtbar / uncurable	60 HB	
			aushärtbar / curable	ausgehärtet / cured	49000 Psi / 340 N/mm ² / 100 HB
	Aluminium - Gusslegierungen cast aluminum alloys		≤ 12% Si, nicht aushärtbar / uncurable	36250 Psi / 250 N/mm ² / 75 HB	
			≤ 12% Si, aushärtbar / curable	ausgehärtet / cured	43500 Psi / 300 N/mm ² / 90 HB
			> 12% Si, nicht aushärtbar / uncurable	63800 Psi / 440 N/mm ² / 130 HB	
	Kupfer und Kupferlegierungen (Bronze / Messing) copper and copper alloys (bronze / brass)		PB > 1 %, Automatenlegierungen / free cutting alloys	54500 Psi / 375 N/mm ² / 110 HB	
		CuZn, CuSnZn	43500 Psi / 300 N/mm ² / 90 HB		
		CuSn, bleifrei & Elektrolitisch / lead free & electrolytic	49000 Psi / 340 N/mm ² / 100 HB		
Magnesium &-Legierungen / Mg-alloys		Magnesium und -Legierungen / and -alloys	70 HB		
S	Warmfeste Legierungen heat-resistant alloys		Fe-Basis / Fe base	geglüht / annealed	99000 Psi / 680 N/mm ² / 200 HB
				ausgehärtet / cured	137750 Psi / 950 N/mm ² / 280 HB
			Ni- oder Co-Basis / Ni- or Co-Base	geglüht / annealed	122000 Psi / 840 N/mm ² / 250 HB
				ausgehärtet / cured	171000 Psi / 1180 N/mm ² / 350 HB
				gegossen / cast	156600 Psi / 1080 N/mm ² / 320 HB
	Titanlegierungen titanium alloys		Reintitan / pure titanium	58000 Psi / 400 N/mm ²	
			Alpha- + Beta-Legierungen / -alloys	ausgehärtet / cured	152250 Psi / 1050 N/mm ²
H	Gehärteter Stahl hardened steel		Beta-Legierungen / -alloys	203000 Psi / 1400 N/mm ² / 410 HB	
				gehärtet & angelassen / hardened & tempered	46-55 HRC
				gehärtet & angelassen / hardened & tempered	56-60 HRC
				gehärtet & angelassen / hardened & tempered	61-65 HRC
	Hartguss / chilled cast iron			gehärtet & angelassen / hardened & tempered	66-70 HRC
Gehärtetes Guss / hardened cast iron			gegossen / cast	400 HB	
O	Nichtmetallische Werkstoffe non-metallic materials			gehärtet & angelassen / hardened & tempered	55 HRC
			Kunststoffe, duroplastisch / plastics, duroplastic	≤ 21750 Psi / ≤ 150 N/mm ²	
			Kunststoffe, thermoplastisch / plastics, thermoplastic	≤ 14500 Psi / ≤ 100 N/mm ²	
			aramidfaserverstärkt / aramid fiber reinforced	≤ 145000 Psi / ≤ 1000 N/mm ²	
			glas/kohlefaserverstärkt / glas/carbon fiber reinforced	≤ 145000 Psi / ≤ 1000 N/mm ²	
	Graphit / graphite				

20 (10 - 50) best choice
20 (10 - 50) conditionally possible

The correct cutting speed must be selected depending on the dimension and application situation.

20 (10 - 50)
recommended starting value (preferred application area)

more informations about feed and cutting depth:
• look at the technical instructions:
General instructions about cutting depth and feed type DT



duemmel.de



MINICUT

MINICUT: D min. $\geq \varnothing 7.0$ mm

TRICUT: D min. $\geq \varnothing 7.8$ mm

MINICUT

Bohrungsbearbeitung

grooving, boring and profiling

Übersicht

summary

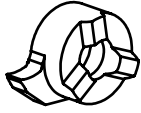

Allgemeine Beschreibung

general instructions

... 7

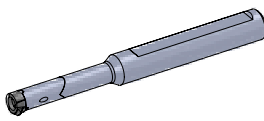

**Klemmhalter
Rundschaft**

**toolholder
straight shank**

**Maße
dimensions
[mm]**

**Seite
page**

**Typ 607 / 608 / 609
611**

Klemmhalter Stahl

toolholder steel

D min. 7.0

... 8

Typ 614 / 616 / 618

Klemmhalter Stahl

toolholder steel

D min. 14.0

... 9

Typ 607 / 608 / 609

Klemmhalter Hartmetall

toolholder carbide

D min. 7.0

... 10

Typ 611

Klemmhalter Hartmetall

toolholder carbide

D min. 11

... 11

Typ 614

Klemmhalter Hartmetall

toolholder carbide

D min. 14

... 12

Typ 616

Klemmhalter Hartmetall

toolholder carbide

D min. 16

... 13

Typ 618

Klemmhalter Hartmetall

toolholder carbide

D min. 18

... 14

Typ V08 / V11

Flexohalter V

Flexo-toolholder V

D min. 7.8 / 11

... 15

Typ 607.A06

Klemmhalter - Adapter Hartmetall
auf System Ultramini

toolholder - adapter carbide
on system Ultramini

D min. 7.0

... 16

Typ 614.A / 618.A

Klemmhalter Axialbearbeitung

toolholder face grooving

D min.
12 / 14 / 16 / 18

... 17

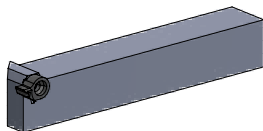

**Klemmhalter
Quadratschaft**

**toolholder
square shank**

**Maße
dimensions
[mm]**

**Seite
page**

Typ 614.SQ / 618.SQ

Klemmhalter Stahl, Quadratschaft,
Axialbearbeitung

toolholder steel, square shank,
face grooving

D min.
12 / 14 / 16 / 18

... 18

Typ 614.SQ.A / 618.SQ.A

Klemmhalter Stahl, Quadratschaft,
abgesetzte Version, Axialbearbeitung

toolholder steel, square shank,
with offset, face grooving

D min.
12 / 14 / 16 / 18

... 19

MINICUT

Bohrungsbearbeitung

grooving, boring and profiling

Übersicht

summary

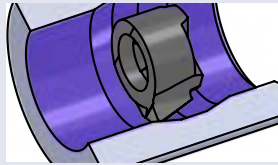

Schneideinsätze Ausdrehen und Kopieren

inserts boring and profiling

Maße dimensions [mm]

Seite page

Typ Ausdrehen und Kopieren	allgemein	type boring and profiling, general	D min. 7 - 15.5	... 21
Typ Ausdrehen und Kopieren	von gehärteten Teilen mit CBN	type boring and profiling, of hardened parts with CBN	D min. 7.8 - 15.5	... 22
Typ Ausdrehen und Kopieren	allgemein, Innenfreistiche DIN 509	type boring and profiling, general, undercuts DIN 509	D min. 7 - 20	... 23
Typ Ausdrehen und Kopieren	Ausdrehen mit spezieller Spantreppe	type boring and profiling, boring with special chipbreaker	D min. 7.8 / 9 / 11	... 24
Typ Ausdrehen und Kopieren	Rückwärtsdrehen	type boring and profiling, backboring	D min. 7.8 - 13.8	... 25

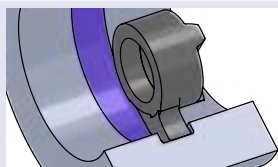
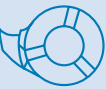

Schneideinsätze Stechdrehen

inserts grooving

Maße dimensions [mm]

Seite page

Typ Stechdrehen	Stechdrehen allgemein	type grooving, general use	D min. 7 / 7.8	... 27
Typ Stechdrehen	für Sicherungsringe DIN 471/472 und Stechdrehen allgemein	type grooving, for circlips DIN 471/472 and grooving	D min. 8	... 28
Typ Stechdrehen	für Sicherungsringe DIN 471/472 und Stechdrehen allgemein	type grooving, for circlips DIN 471/472 and grooving	D min. 9	... 29
Typ Stechdrehen	für Sicherungsringe DIN 471/472 und Stechdrehen allgemein	type grooving, for circlips DIN 471/472 and grooving	D min. 11	... 30
Typ Stechdrehen	für Sicherungsringe DIN 471/472 und Stechdrehen allgemein	type grooving, for circlips DIN 471/472 and grooving	D min. 14	... 31
Typ Stechdrehen	für Sicherungsringe DIN 471/472 und Stechdrehen allgemein	type grooving, for circlips DIN 471/472 and grooving	D min. 16	... 32
Typ Stechdrehen	Stechdrehen allgemein	type grooving, general use	D min. 18 / 20	... 34
Typ Stechdrehen	Stechdrehen allgemein, große Einstechtiefe	type grooving, general use, maximum depth of groove	D min. 16 / 17	... 35

↳ ...

MINICUT

Bohrungsbearbeitung

grooving, boring and profiling

Übersicht

summary

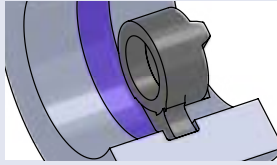

Schneideinsätze Stechdrehen

inserts grooving

Maße dimensions [mm]

Seite page

... ↴

	Typ Stechdrehen	NC-Feindrehen	type grooving, NC-profiling	D min. 7.8 - 20	... 36
	Typ Stechdrehen	NC-Feindrehen, große Einstechtiefe	type grooving, NC-profiling, maximum depth of groove	D min. 16 / 17	... 40
	Typ Stechdrehen	Stechdrehen und Kopieren Vollradius	type grooving, grooving and profiling, full radius	D min. 8 - 16 R 0.4 - 2.0	... 41
	Typ Stechdrehen	Ausdrehen und Fasen	type grooving, boring and chamfering	D min. 7 - 14	... 45
	Typ Stechdrehen	Vorstechen und Fasen	type grooving, pregrooving and chamfering	D min. 8 - 16	... 46

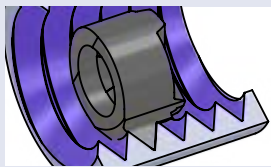

Schneideinsätze Gewindedrehen, innen

inserts threading, internal

Maße dimensions [mm]

Seite page

	Typ Gewindedrehen	metrisches ISO-Gewinde, Teilprofil, innen	type threading, metric ISO-thread, partial profile, internal	D min. 7 / 8 / 9 P = 0.5 - 3.5	... 48
	Typ Gewindedrehen	metrisches ISO-Gewinde, Teilprofil, innen	type threading, metric ISO-thread, partial profile, internal	D min. 11 / 14 / 16 P = 0.5 - 3.0	... 49
	Typ Gewindedrehen	metrisches ISO-Gewinde, Vollprofil, innen	type threading, metric ISO-thread, full profile, internal	D min. 9 / 11 P = 0.5 - 3.0	... 50
	Typ Gewindedrehen	metrisches ISO-Gewinde, Vollprofil, innen	type threading, metric ISO-thread, full profile, internal	D min. 14 / 16 P = 0.5 - 4.0	... 51
	Typ Gewindedrehen	NPT Vollprofil, innen	type threading, NPT full profile, internal	D min. 8	... 52
	Typ Gewindedrehen	Whitworth-Gewinde, Vollprofil, innen	type threading, Whitworth thread, full profile, internal	D min. 11 / 14 / 16	... 53
	Typ Gewindedrehen	Trapezgewinde, Teilprofil, innen	type threading, trapezoidal thread, partial profile, internal	D min. 9 / 10 / 11 P = 1.5 - 4.0	... 54
	Typ Gewindedrehen	Trapezgewinde, Teilprofil, innen	type threading, trapezoidal thread, partial profile, internal	D min. 14 / 16 P = 2.0 - 6.0	... 55

MINICUT

Bohrungsbearbeitung

grooving, boring and profiling

Übersicht

summary

	Schneideinsätze Axialstechen	inserts face grooving	Maße dimensions [mm]	Seite page
---	---------------------------------	--------------------------	----------------------------	---------------

Typ Axialstechen	allgemein	type face grooving	D min. 14 / 18	... 57
Typ Axialstechen	am Zapfen vorbei	type face grooving, in pivots,	D min. 12 / 16	... 58
Typ Axialstechen	Vollradius	type face grooving, full radius	D min. 14 t max. 5	... 59
Typ Axialstechen	am Zapfen vorbei, Vollradius	type face grooving, in pivots, full radius	D min. 12 t max. 5	... 60



	Sets Minicut Halter und Schneiden (Rechte Ausführung)	sets Minicut toolholder and inserts (righthand version)	Maße dimensions [mm]	Seite page
--	---	---	----------------------------	---------------

SET-MC08-LF/R	Auswahl RS008 / RS08	selection RS008 / RS08	D min. 8	... 61
SET-MC11-LF/R	Auswahl RS011 / RS11	selection RS011 / RS11	D min. 11	... 61
SET-MC14-LF/R	Auswahl RS014 / RS14	selection RS014 / RS14	D min. 14	... 62

	Technische Hinweise	Technical Instructions	Seite page
---	---------------------	------------------------	---------------

Schnittwerte und Anzahl der Schnitte beim Gewindedrehen	cutting data and number of passes for threading	... 68
Gewinde schneiden	threading	... 69
Hartmetallsorten und Beschichtungen	carbide grades and coatings	... 70
Schnittdatenempfehlung	speed and feed recommendation	... 72

TRICUT

Bohrungsbearbeitung

boring and profiling

Übersicht

summary

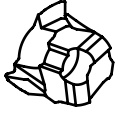

Allgemeine Beschreibung
Spangeometrien Tricut

general instructions
cutting geometries Tricut

... 64

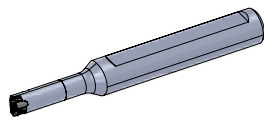

**Klemmhalter
Rundschaft**

**toolholder
straight shank**

**Maße
dimensions
[mm]**

**Seite
page**

Typ TC08. ... ST

Klemmhalter Stahl
mit Innenkühlung

toolholder steel
with internal cooling

D min. 7.8

... 65

Typ TC08. ... HM

Klemmhalter Hartmetall
mit Innenkühlung

toolholder carbide
with internal cooling

D min. 7.8

... 66

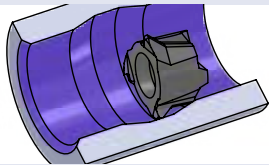

**Schneideinsätze
Ausdrehen und Kopieren**

**inserts
boring and profiling**

**Maße
dimensions
[mm]**

**Seite
page**

Typ RTC08.

Ausdrehen und Kopieren,
allgemein

boring and profiling,
general

D min. 7.8

... 67

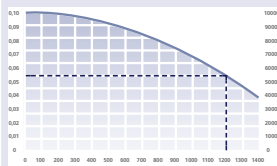

Technische Hinweise

Technical Instructions

**Seite
page**

Hartmetallsorten und
Beschichtungen

carbide grades and coatings

... 70

Schnittdatenempfehlung

speed and feed recommendation

... 72

MINICUT

Bohrungsbearbeitung

grooving, boring and profiling

Allgemeine Beschreibung

general instruction

Minicut:

Bei dem System Minicut werden die austauschbaren Hartmetallschneiden mittels der bewährten Dreirippenverzahnung stirnseitig verschraubt. Diese gewährleistet beste Wiederholgenauigkeit bei einfachster Handhabung.

Minicut:

In the system Minicut the indexible carbide inserts are frontal screwed by the proven interface. This guarantees best repeat accuracy by most simple handling.

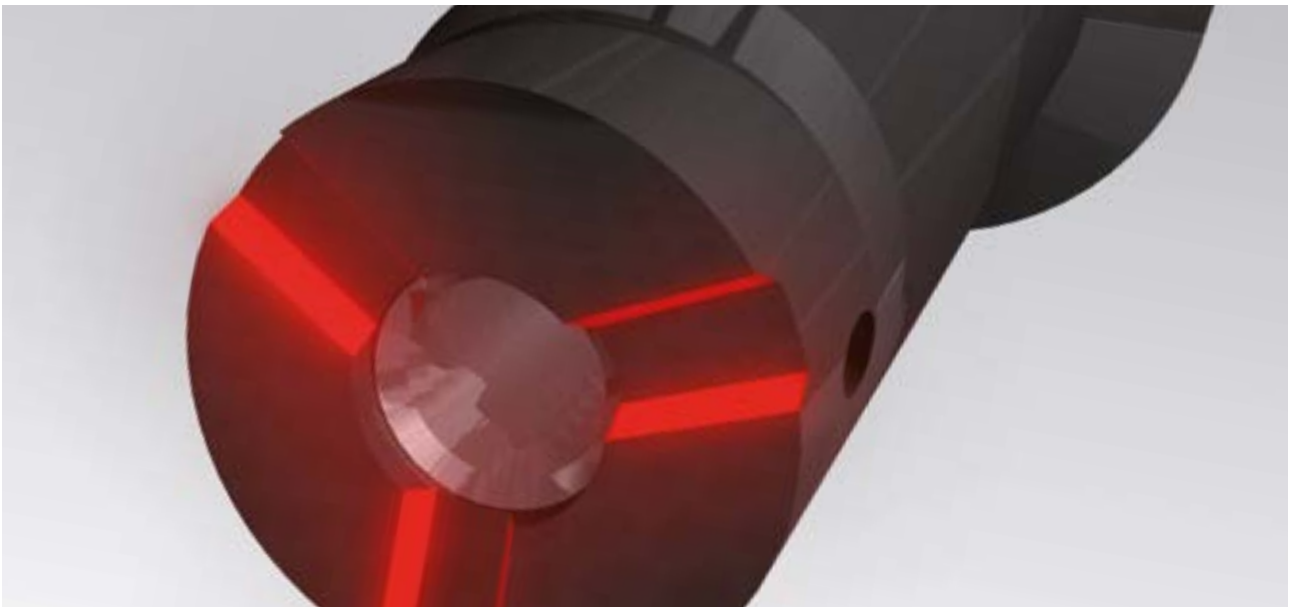
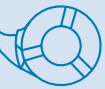

MINICUT

Bohrungsbearbeitung

grooving, boring and profiling

Typ 607 / 608 / 609 / 611

Klemmhalter Stahl

D min. 7.0 mm

toolholder steel

D min. 7.0 mm

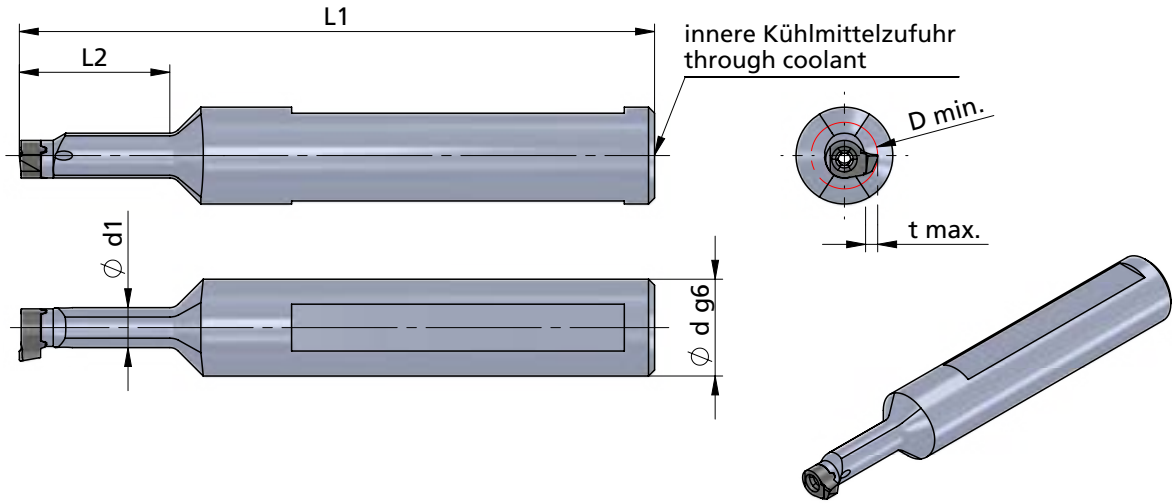

Beispielzeichnung
exemplary application

Abmessungen in mm

dimensions in mm



Bestellnummer part number	Ø d g6	Ø d (inch)	Ø d1	L1	L2	Typ: t max. / D min.	Spannschraube screw	Schraubenschlüssel wrench	Anzugs- drehmoment torque	für Schneidplatte use with insert
607.0016.1ST	16		4.8x6	80	12					
607.0016.1E.ST	16		4.8x6	85	21	R/L S007: 1.0 / ø7 R/L S007: 2.0 / ø7.8	A.SPS017	T7F-P	0.8 Nm	R/L S07 R/L S007
608.0158.1E.ST	15.87	5/8"	6x7	90	22					
608.0016.1ST	16		6	80	12					
608.0016.1E.ST	16		6x7	90	22	R/L S008: 1.0 / ø8				R/L S08 R/L S008
609.0158.1E.ST	15.87	5/8"	6.6x7.4	105	25					
609.0016.1ST	16		6.6x7.4	95	14					
609.0016.1E.ST	16		6.6x7.4	105	25	R/L S009: 1.8 / ø9 R/L S09: 2.8 / ø10	A.SPS016	T8F-P	1.2 Nm	R/L S09 R/L S009
611.0158.2E.ST	15.87	5/8"	8x9.5	110	29					
611.0016.2ST	16		8	97	16					
611.0016.2E.ST	16		8x9.5	110	29	R/L S011: 2.3 / ø11	A.SPS021	T10F-P	3.5 Nm	R/L S11 R/L S011

MINICUT

Bohrungsbearbeitung

grooving, boring and profiling

Typ 614 / 616 / 618

Klemmhalter Stahl

toolholder steel

D min. 14 mm

D min. 14 mm

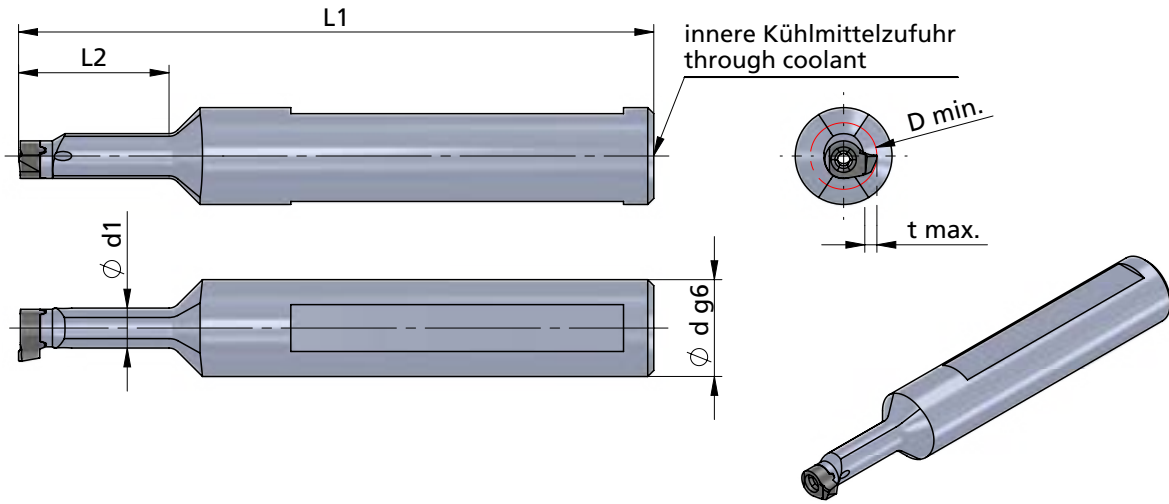

Beispielzeichnung
exemplary application

Abmessungen in mm

dimensions in mm



Bestellnummer part number	Ø d g6	Ø d (inch)	Ø d1	L1	L2	Typ: t max. / D min.	Spannschraube screw	Schraubenschlüssel wrench	Anzugs- drehmoment torque	für Schneidplatte use with insert
614.0127.3ST	12.7	1/2"	9.5x11	100	18					
614.0158.3E.ST	15.87	5/8"	9.5x11	120	38	R/L S014: 4.0 / Ø14				R/L S14 R/L S014
614.0016.3ST	16		9.5x11	100	18	R/L S55: 5.5 / Ø16	A.SPS026	T15F-P	4.5 Nm	R/L S55 R/L S65
614.0016.3E.ST	16		9.5x11	120	38	R/L S65: 6.5 / Ø17				
616.0158.3E.ST	15.87	5/8"	11x13.5	120	42					R/L S16 R/L S016
616.0016.3ST	16		11	100	22	R/L S016: 4.3 / Ø16				
616.0016.3E.ST	16		11x13.5	120	42					
618.0020.3ST	20		11.5x14.2	95	25					
618.0020.3E.ST	20		11.5x14.2	120	45	R/L S18: 6 / Ø18 R/L S20: 8 / Ø20	A.SPS029	T20F-P	7.0 Nm	R/L S18 R/L S20

Bestellbeispiel:
614.0127.3ST

order-example:
614.0127.3ST

MINICUT

Bohrungsbearbeitung

grooving, boring and profiling

Typ 607 / 608 / 609

Klemmhalter Hartmetall

D min. 7.0 mm

toolholder carbide

D min. 7.0 mm

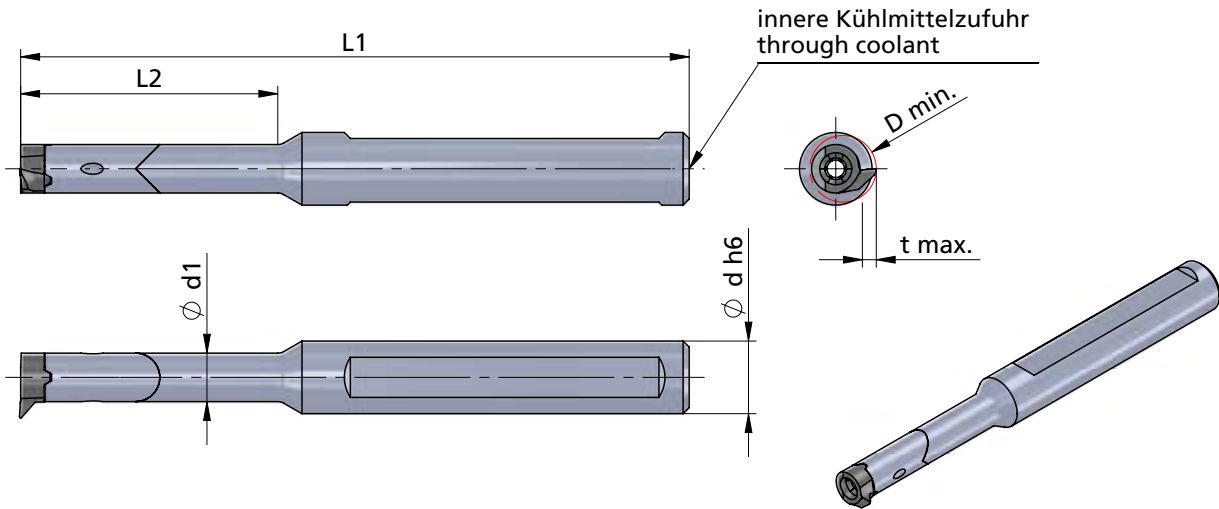

Beispielzeichnung
exemplary application

Abmessungen in mm

dimensions in mm



Bestellnummer part number	Ø d h6	Ø d (inch)	Ø d1	L1	L2	Typ: t max. / D min.	Spannschraube screw	Schraubenschlüssel wrench	Anzugs- drehmoment torque	für Schneidplatte use with insert
607.0012.1HM	12		4.8x6.0	80	21	R/L S007: 1.0 / ø7	A.SPS017	T7F-P	0.8 Nm	R/L S07 R/L S007
607.0012.2HM	12		4.8x6.0	90	30					
607.0012.3HM	12		4.8x6.0	100	42					
608.0012.1HM	12		6	80	21	R/L S008: 1.0 / ø8	A.SPS016	T8F-P	1.2 Nm	R/L S08 R/L S008
608.0012.2HM	12		6	90	30					
608.0012.3HM	12		6	100	42					
608.0012.4HM	12		6	115	50					
608.0127.1HM	12.7	1/2"	6	80	21	R/L S009: 1.8 / ø9	A.SPS016	T8F-P	1.2 Nm	R/L S09 R/L S009
608.0127.2HM	12.7	1/2"	6	90	30					
608.0127.3HM	12.7	1/2"	6	100	42					
609.0012.1HM	12		6.6x7.4	90	22	R/L S09.10: 2.8 / ø10				
609.0012.2HM	12		6.6x7.4	98	30					
609.0012.3HM	12		6.6x7.4	110	42					
609.0012.4HM	12		6.6x7.4	122	56					

Hinweis:
Hartmetall-Klemmhalter mit beschädigter
Schneidplattenaufnahme können durch unseren
Reparaturservice instand gesetzt werden.

note:
carbide-toolholder with damaged seating can be
repaired by Dümmel.

Bestellbeispiel:
607.0012.1HM

order-example:
607.0012.1HM

MINICUT

Bohrungsbearbeitung

grooving, boring and profiling

Typ 611

Klemhalter Hartmetall

toolholder carbide

D min. 11 mm

D min. 11 mm

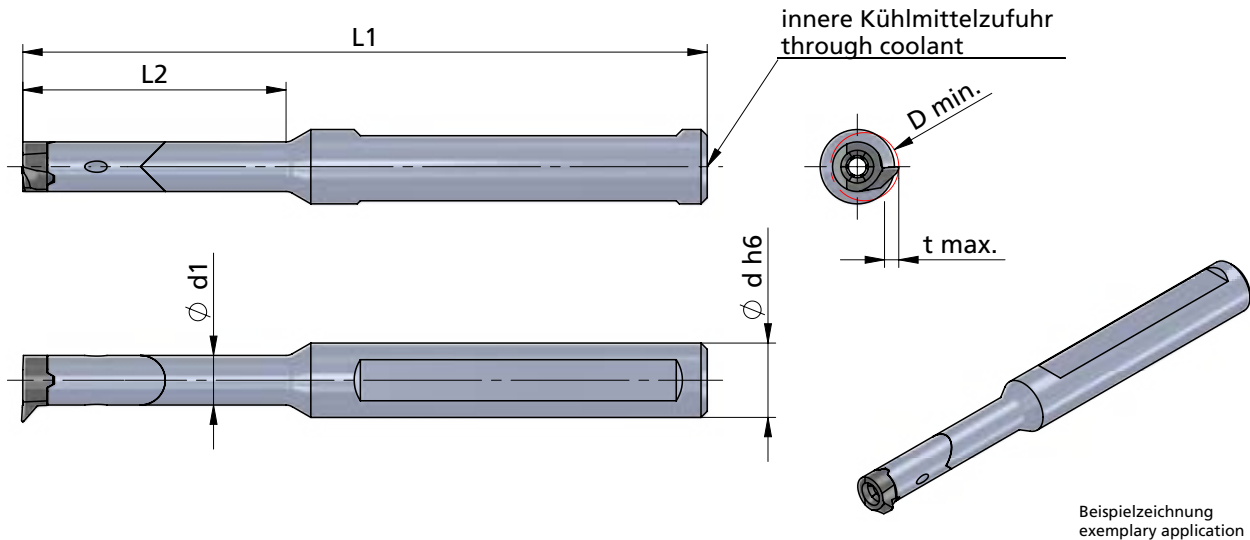
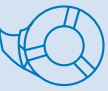

Beispielzeichnung
exemplary application

Abmessungen in mm

dimensions in mm

Bestellnummer part number	Ø d h6	Ø d (inch)	Ø d1	L1	L2	Typ: t max. / D min.	Spannschraube screw	Schraubenschlüssel wrench	Anzugs- drehmoment torque	für Schneidplatte use with insert
611.0012.1HM	12		8	95	29	R/L S011: 2.3 / Ø11	A.SPS021	T10F-P	3.5 Nm	R/L S11 R/L S011
611.0012.2HM	12		8	110	42					
611.0012.3HM	12		8	120	56					
611.0012.4HM	12		8	130	64					
611.0127.1HM	12.7	1/2"	8	95	29					
611.0127.2HM	12.7	1/2"	8	110	42					
611.0127.3HM	12.7	1/2"	8	120	56					

Hinweis:
Hartmetall-Klemhalter mit beschädigter Schneidplattenaufnahme können durch unseren Reparaturservice in stand gesetzt werden.

Bestellbeispiel:
611.0012.1HM

note:
carbide-toolholder with damaged seating can be repaired by Dümmel.

order-example:
611.0012.1HM

MINICUT

Bohrungsbearbeitung

grooving, boring and profiling

Typ 614

Klemmhalter Hartmetall

D min. 14 mm

toolholder carbide

D min. 14 mm

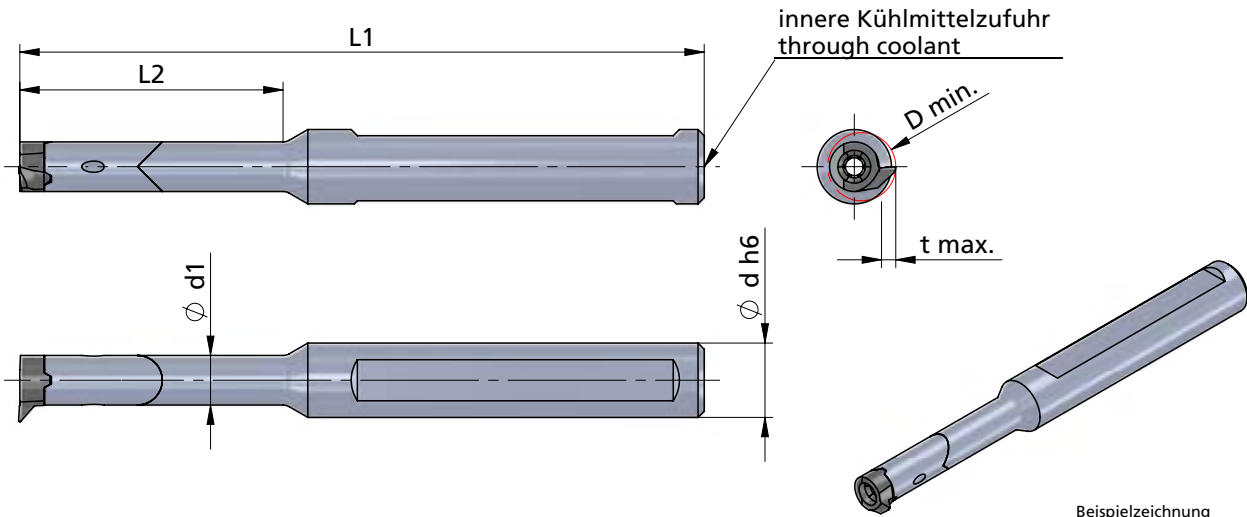

Beispielzeichnung
exemplary application

Abmessungen in mm

dimensions in mm



Bestellnummer part number	Ø d h6	Ø d (inch)	Ø d1	L1	L2	Typ: t max. / D min.	Spannschraube screw	Schraubenschlüssel wrench	Anzugs- drehmoment torque	für Schneidplatte use with insert
614.0012.1HM	12		9.5x11	100	34					
614.0012.2HM	12		9.5x11	110	45					
614.0012.3HM	12		9.5x11	130	64					
614.0127.1HM	12.7	1/2"	9.5x11	100	34					
614.0127.2HM	12.7	1/2"	9.5x11	110	45					
614.0127.3HM	12.7	1/2"	9.5x11	130	64					
614.0158.1HM	15.87	5/8"	9.5x11	100	34					
614.0158.2HM	15.87	5/8"	9.5x11	110	45					
614.0158.3HM	15.87	5/8"	9.5x11	130	64					
614.0016.1HM	16		9.5x11	100	34					
614.0016.2HM	16		9.5x11	110	45					
614.0016.3HM	16		9.5x11	130	64					
614.0016.4HM	16		9.5x11	140	75					

Hinweis:
Hartmetall-Klemmhalter mit beschädigter
Schneidplattenaufnahme können durch unseren
Reparaturservice instand gesetzt werden.

note:
carbide-toolholder with damaged seating can be
repaired by Dümmel.

Bestellbeispiel:
614.0012.1HM

order-example:
614.0012.1HM

MINICUT

Bohrungsbearbeitung

grooving, boring and profiling

Typ 616

Klemmhalter Hartmetall

toolholder carbide

D min. 16 mm

D min. 16 mm

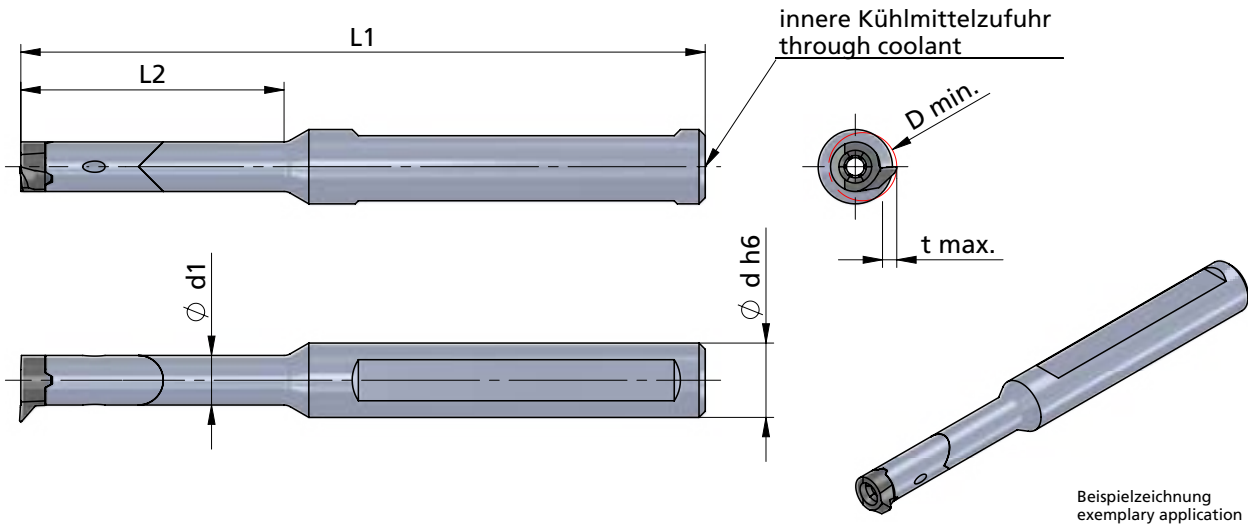

Abmessungen in mm

dimensions in mm



Bestellnummer part number	Ø d h6	Ø d (inch)	Ø d1	L1	L2	Typ: t max. / D min.	Spannschraube screw	Schraubenschlüssel wrench	Anzugs- drehmoment torque	für Schneidplatte use with insert
616.0012.1HM	12		11	130	40	R/L S016: 4.3 / ø16	A.SPS029	T20F-P	7.0 Nm	R/L S16 R/L S016
616.0012.2HM	12		11	130	56					
616.0012.3HM	12		11	150	80					
616.0127.1HM	12.7	1/2"	11	130	40					
616.0127.2HM	12.7	1/2"	11	130	56					
616.0127.3HM	12.7	1/2"	11	150	80					
616.0158.1HM	15.87	5/8"	11	130	40					
616.0158.2HM	15.87	5/8"	11	130	56					
616.0158.3HM	15.87	5/8"	11	150	80					
616.0016.1HM	16		11	130	40					
616.0016.2HM	16		11	130	56					
616.0016.3HM	16		11	150	80					

Hinweis:
Hartmetall-Klemmhalter mit beschädigter Schneidplattenaufnahme können durch unseren Reparaturservice in stand gesetzt werden.

Bestellbeispiel:
616.0012.1HM

note:
carbide-toolholder with damaged seating can be repaired by Dümmel.

order-example:
616.0012.1HM

MINICUT

Bohrungsbearbeitung

grooving, boring and profiling

Typ 618

Klemmhalter Hartmetall

D min. 18 mm

toolholder carbide

D min. 18 mm

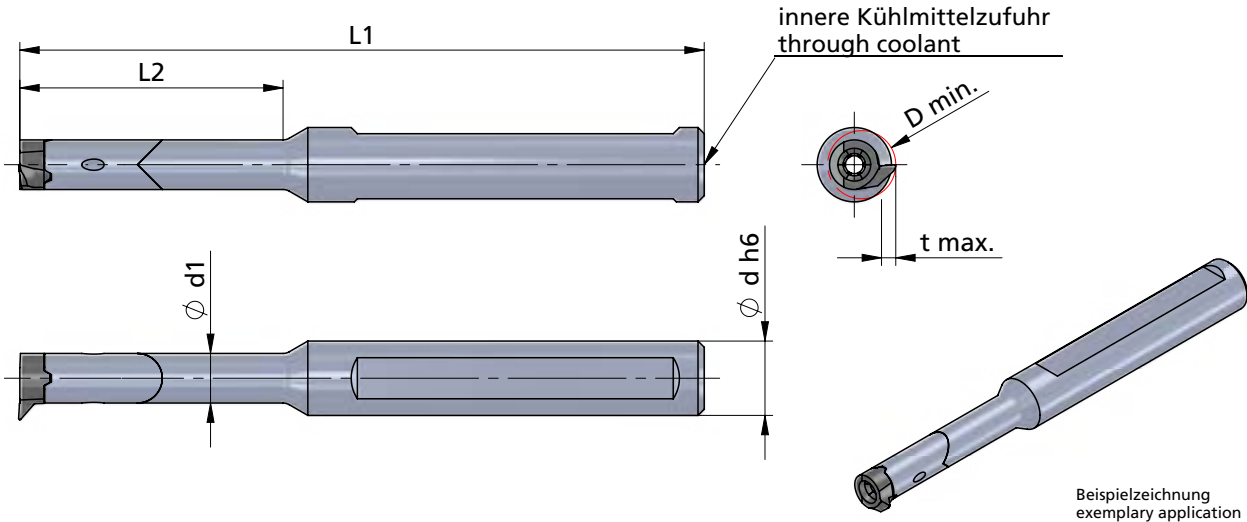

Beispielzeichnung
exemplary application

Abmessungen in mm

dimensions in mm



Bestellnummer part number	$\phi d h_6$	ϕd_1	L1	L2	Typ: t max. / D min.	Spannschraube screw	Schraubenschlüssel wrench	Anzugs- drehmoment torque	für Schneidplatte use with insert
618.0016.1HM	16	11.5x14.3	100	42					
618.0016.2HM	16	11.5x14.3	130	60	R/L S18: 6.0 / $\phi 18$	A.SPS029	T20F-P	7.0 Nm	R/L S18
618.0016.3HM	16	11.5x14.3	160	85	R/L S20: 8.0 / $\phi 20$				R/L S20
618.0020.3HM	20	11.5x14.3	160	85					

Hinweis:
Hartmetall-Klemmhalter mit beschädigter Schneidplattenaufnahme können durch unseren Reparaturservice in stand gesetzt werden.

note:
carbide-toolholder with damaged seating can be repaired by Dümmel.

Bestellbeispiel:
618.0016.1HM

order-example:
618.0016.1HM

MINICUT

Bohrungsbearbeitung

grooving, boring and profiling

Typ V08 / V11

Flexohalter V
Flexible Bearbeitungslänge L1

D min. 7.8 / 11 mm

Flexo-toolholder V
Flexible working length L1

D min. 7.8 / 11 mm

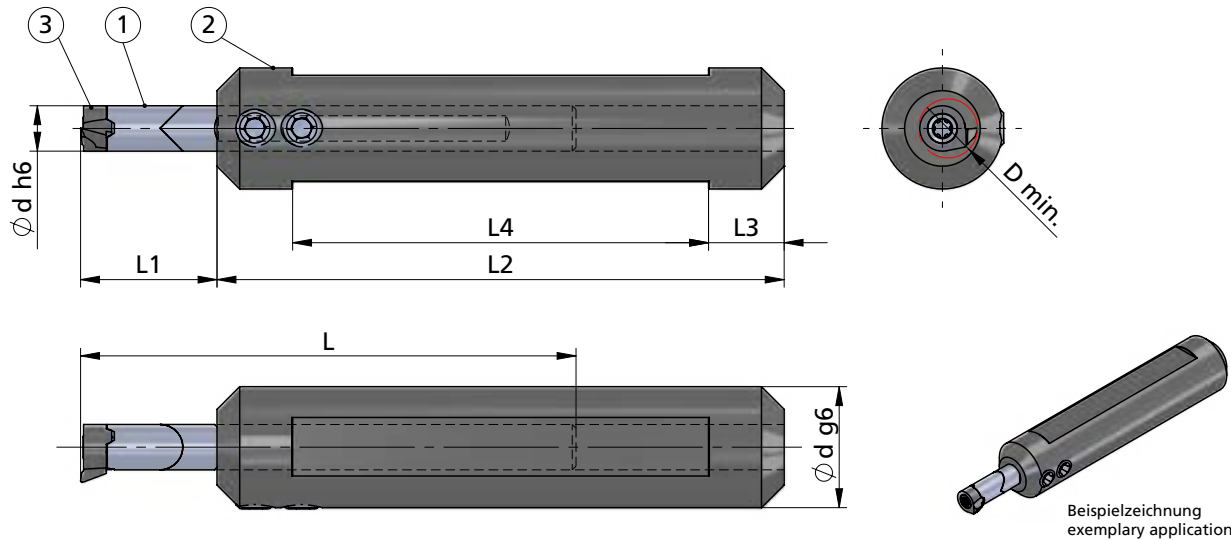

Beispielzeichnung
exemplary application

Halter für rechte und linke
Schneideinsätze einsetzbar

* V08... ohne IK!

Abmessungen in mm

toolholder for right and left
inserts usable

* V08... without IK!

dimensions in mm



Bestellnummer part number	Position	D min.	Ø d h6	L	L1 min.	L1 max.	Spannschraube screw	Schraubenschlüssel wrench	Anzugs- drehmoment torque	für Grundhalter for toolholder basic	für Schneidplatte use with insert	3
V08.0006.2HM *	1	7.8	6	65	18	42	A.SPS016	T8F-P	1.2 Nm	VG08	R/L S08 / R/L S008	
V08.0006.4HM *		7.8	6	103	40	80						
V11.0008.2HM		11	8	79	20	55	A.SPS021	T10F-P	3.5 Nm	VG11	R/L S11 / R/L S011	
V11.0008.4HM		11	8	129	50	105						
Bestellnummer part number	Position				Spannschraube screw	Schraubenschlüssel wrench			für Halter for holder			
VG08-16	2				A.GST008	111.645	1.2 Nm	V08				
VG08-20					A.GST008			V11				
VG11-16					A.GST007							
VG11-20					A.GST008							

Hinweis:
Hartmetall-Klemmhalter mit beschädigter
Schneidplattenaufnahme können durch unseren
Reparaturservice instand gesetzt werden.

Bestellbeispiel:
V08.0006.2HM

note:
carbide-toolholder with damaged seating can be
repaired by Dümmel.

order-example:
V08.0006.2HM

MINICUT

Bohrungsbearbeitung

grooving, boring and profiling

Typ 607.A06

Klemmhalter - Adapter Hartmetall auf System Ultramini

D min. 7.0 mm

toolholder - adapter carbide on system Ultramini

D min. 7.0 mm

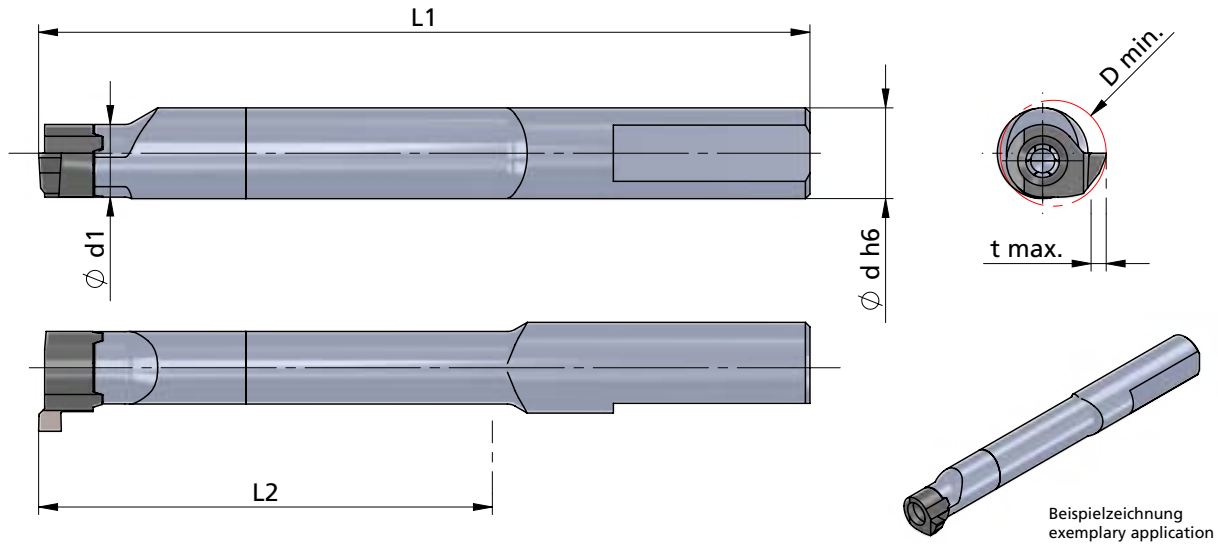

Abmessungen in mm

dimensions in mm

Bestellnummer part number	Ø d h6	Ø d1	L1	L2	Typ: t max. / D min.	Spannschraube screw	Schraubenschlüssel wrench	Anzugs- drehmoment torque	für Schneidplatte use with insert	für Ultramini - Klemmhalter Typ use with Ultramini - toolholder type
607.A06.20HM	6	4.8	41	20	R/L S007: 1.0 / ø7 R/L S007: 2.0 / ø7.8	A.SPS017	T7F-P	0.8 Nm	R/L S07 R/L S007	660,... ...6 676,...
607.A06.30HM	6	4.8	51	30						
607.A06.40HM	6	4.8	61	40						
607.A06.50HM	6	4.8	71	50						
607.A06.60HM	6	4.8	81	60						

Hinweis:
Hartmetall-Klemmhalter mit beschädigter
Schneidplattenaufnahme können durch unseren
Reparaturservice instand gesetzt werden.

note:
carbide-toolholder with damaged seating can be
repaired by Dümmel.

Bestellbeispiel:
607.A06.20HM

order-example:
607.A06.20HM

MINICUT

Bohrungsbearbeitung

grooving, boring and profiling

Typ 614.A / 618.A

Klemmhalter Axialbearbeitung

toolholder face grooving

D min. 12 / 14 / 16 / 18 mm

D min. 12 / 14 / 16 / 18 mm



Abbildung: Halter (R)
Schneideinsatz (R)

Rechter Halter - rechte Platte
Linker Halter - linke Platte

Abmessungen in mm

drawing: toolholder (R)
insert (R)

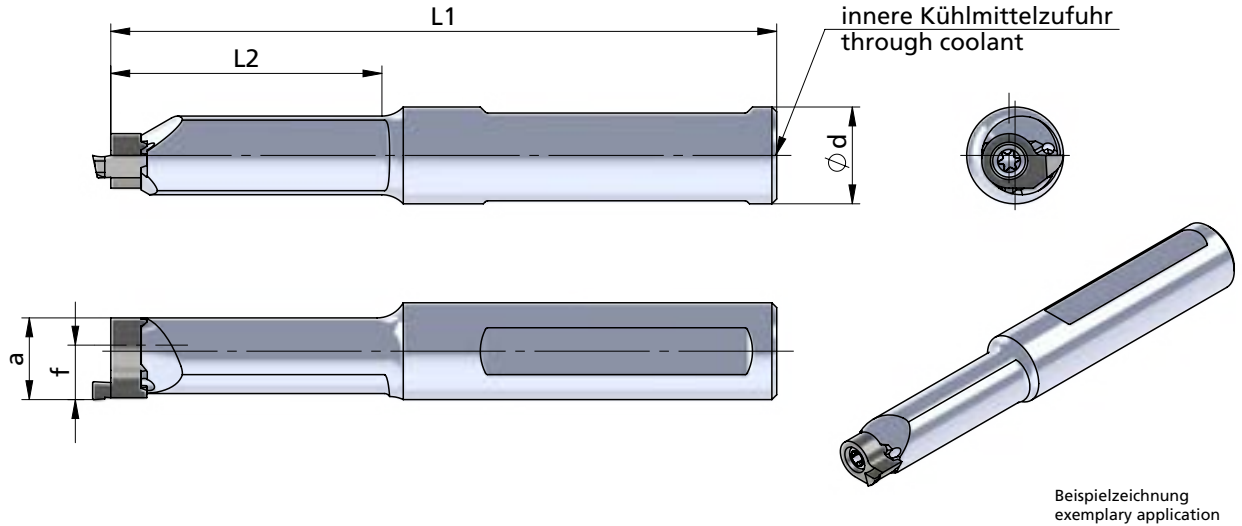
toolholder R - insert R
toolholder L - insert L

dimensions in mm



Bestellnummer part number	Ø d g6	Ø d (inch)	a	L1	L2	f	Spannschraube screw	Schraubenschlüssel wrench	Anzugsdrehmoment torque	für Schneidplatte use with insert
R/L 614.A016.3ST	16		13.5	90	25	*	A.SPS026	T15F-P	4.5 Nm	R/L S014
R/L 614.A016.3E.ST	16		13.5	110	45	*				
Bestellnummer part number	Ø d h6	Ø d (inch)	a	L1	L2	f	Spannschraube screw	Schraubenschlüssel wrench	Anzugsdrehmoment torque	für Schneidplatte use with insert
R/- 614.A158.3HM	15.87	5/8"	13.5	120	62	*	A.SPS026	T15F-P	4.5 Nm	R/L S014
R/L 614.A016.3HM	16		13.5	120	62	*				
Bestellnummer part number	Ø d g6	Ø d (inch)	a	L1	L2	f	Spannschraube screw	Schraubenschlüssel wrench	Anzugsdrehmoment torque	für Schneidplatte use with insert
R/L 618.A016.3ST	16		16.5/17	90	30	*	A.SPS029	T20F-P	7.0 Nm	R/L S018

Hinweis:
Hartmetall-Klemmhalter mit beschädigter Schneidplattenaufnahme können durch unseren Reparaturservice instand gesetzt werden.

Bestellbeispiel:
für rechte Ausführung
R614.A016.3ST

* f-Maß ist schneidenabhängig
f-measure is depending on the insert

note:
carbide-toolholder with damaged seating can be repaired by Dümmel.

order-example:
righthand version
R614.A016.3ST

MINICUT

Bohrungsbearbeitung

grooving, boring and profiling

Typ 614.SQ / 618.SQ

Klemhalter Stahl, Quadratschaft, Axialbearbeitung

toolholder steel, square shank, face grooving

D min. 12 / 14 / 16 / 18 mm

D min. 12 / 14 / 16 / 18 mm



Abbildung: Halter (R)
Schneideinsatz (L)
Bitte beachten: Rechter Halter wird mit linker Platte bestückt und umgekehrt.
Abmessungen in mm

drawing: toolholder (R)
insert (L)
Please notice: Use right hand toolholder with left hand insert and vice versa.
dimensions in mm

Beispielzeichnung
exemplary application

Bestellnummer part number	H	H (inch)	B	B (inch)	L1	c	Spannschraube screw	Schraubenschlüssel wrench	Anzugs- drehmoment torque	für Schneidplatte use with insert
R/L 614.SQ12.ST	12		12		100	2	A.SPS026	T15F-P	4.5 Nm	R/L S014 R/L S14 R/L S55 R/L S65
R/L 614.0.500.ST	12.7	1/2"	12.7	1/2"	100	2				
R/L 614.0.625.ST	15.87	5/8"	15.87	5/8"	100	6				
R/L 614.SQ16.ST	16		16		125	6				
R/L 614.SQ20.ST	20		20		125	10				
R/L 614.SQ25.ST	25		25		150	15				
Bestellnummer part number	H		B		L1	c	Spannschraube screw	Schraubenschlüssel wrench	Anzugs- drehmoment torque	für Schneidplatte use with insert
R/L 618.SQ20.ST	20		20		125	10	A.SPS029	T20F-P	7.0 Nm	R/L S018 R/L S18 R/L S20
R/L 618.SQ25.ST	25		25		150	15				

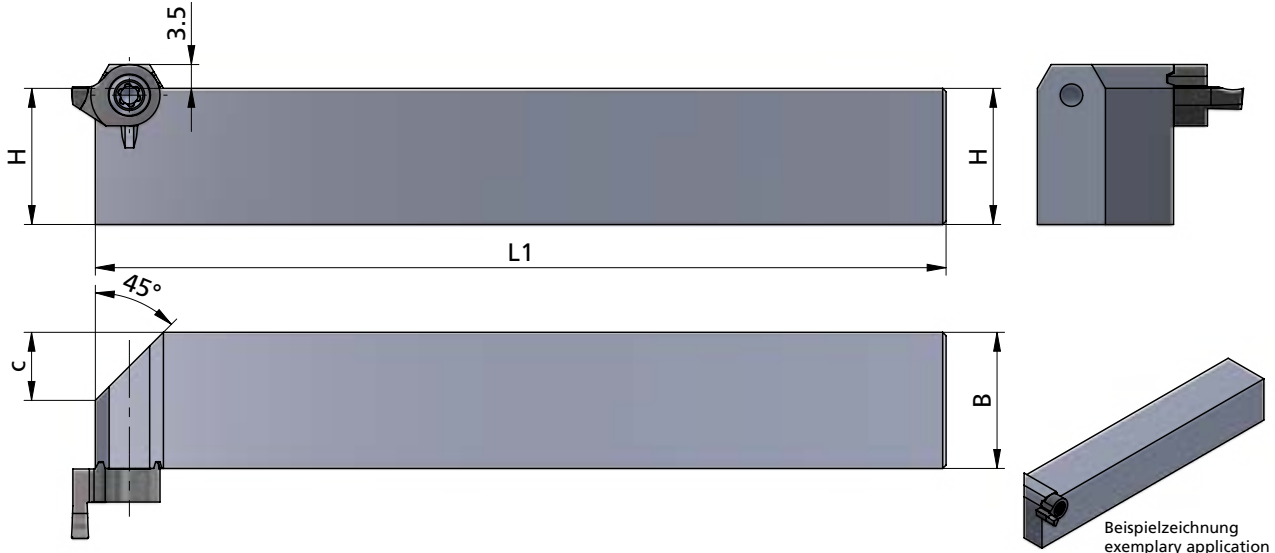
MINICUT

Bohrungsbearbeitung

grooving, boring and profiling

Typ 614.SQ.A / 618.SQ.A

Klemmhalter Stahl, Quadratschaft, abgesetzte Version, Axialbearbeitung

toolholder steel, square shank, with offset, face grooving

D min. 12 / 14 / 16 / 18 mm

D min. 12 / 14 / 16 / 18 mm

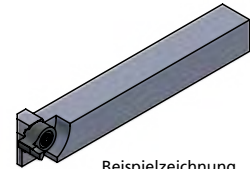
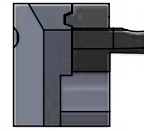
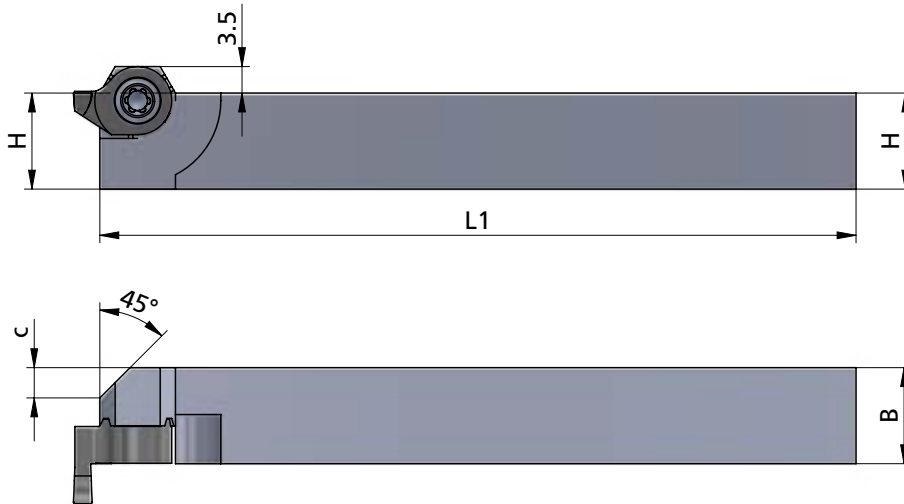

Beispielzeichnung
exemplary application

Abbildung: Halter (R)
Schneideinsatz (L)
Bitte beachten: Rechter Halter wird mit linker Platte bestückt und umgekehrt.
Abmessungen in mm

drawing: toolholder (R)
insert (L)
Please notice: Use right hand toolholder with left hand insert and vice versa.
dimensions in mm

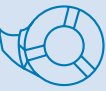

Bestellnummer part number	H	H (inch)	B	B (inch)	L1	c	Spannschraube screw	Schraubenschlüssel wrench	Anzugs- drehmoment torque	für Schneidplatte use with insert
R/L 614.SQ12.ST.A	12		12		100	4	A.SPS026	T15F-P	4.5 Nm	R/L S014 R/L S14 R/L S55 R/L S65
R/L 614.0.500.ST.A	12.7	1/2"	12.7	1/2"	100	4				
R/L 614.0.625.ST.A	15.87	5/8"	15.87	5/8"	100	5				
R/L 614.SQ16.ST.A	16		16		120	5				
R/L 614.SQ20.ST.A	20		20		120	5				
R/L 614.SQ25.ST.A	25		25		150	9				
Bestellnummer part number	H		B		L1	c	Spannschraube screw	Schraubenschlüssel wrench	Anzugs- drehmoment torque	für Schneidplatte use with insert
R/L 618.SQ20.ST.A	20		20		120	5	A.SPS029	T20F-P	7.0 Nm	R/L S018 R/L S18 R/L S20
R/L 618.SQ25.ST.A	25		25		150	9				

Bestellbeispiel:
für rechte Ausführung
R614.SQ12.ST.A

order-example:
righthand version
R614.SQ12.ST.A

MINICUT

Bohrungsbearbeitung

grooving, boring and profiling

Impressionen

impressions

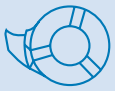

MINICUT

Bohrungsbearbeitung

grooving, boring and profiling

Typ Ausdrehen und Kopieren

allgemein

type boring and profiling,
general

D min. 7 - 15.5 mm

D min. 7 - 15.5 mm

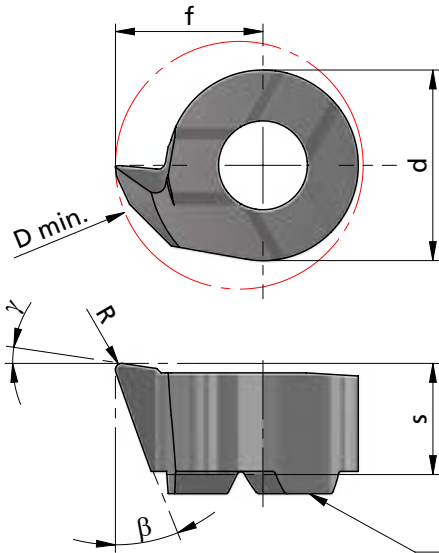

Klemmhalter Stirnseite
toolholder face

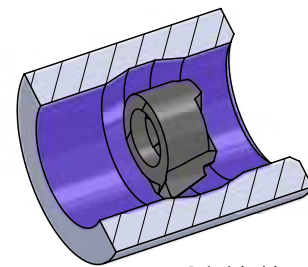

Beispielzeichnung
exemplary application

Rechts (R): wie gezeichnet
Links (L): spiegelbildlich

righthand (R): as shown
lefthand version (L): mirror image

Abmessungen in mm

dimensions in mm

Bestellnummer part number	β	γ	R	f	s	d	ap *	D min.				Klemmhalter Typ toolholder type
									K10F	AL41F	P18C	
R/L S07.1841.01	18°	8°	0.1	4.15	3.7	4.8	0.13	7	●			607...
R/L S07.1841.02	18°	8°	0.2	4.15	3.7	4.8	0.25	7		●		
R/L S08.1846.005	18°	8°	0.05	4.65	3.5	6	0.07	7.8	●			608...
R/L S08.1846.02	18°	8°	0.2	4.65	3.5	6	0.25	7.8		●		
R/L S08.2046.02	20°	20°	0.2	4.65	3.5	6	0.25	7.8		●		609...
R/L S09.1855.02	18°	8°	0.2	5.50	3.6	6.2	0.25	9	●			
R/L S09.2055.02	20°	20°	0.2	5.50	3.6	6.2	0.25	9		●		
R/L S11.1855.02	18°	8°	0.2	5.50	4.2	8	0.25	9.8	●			611...
R/L S11.1867.02	18°	8°	0.2	6.70	4.2	8	0.25	11		●		
R/L S11.2067.02	20°	20°	0.2	6.70	4.2	8	0.25	11		●		614...
R/L S14.1867.02	18°	8°	0.2	8.70	5.3	9	0.25	13.8	●			
R/L S14.2087.02	20°	20°	0.2	8.70	5.3	9	0.25	13.8		●		
R/L S16.1897.02	18°	8°	0.2	9.70	5.4	11	0.25	15.5		●		616...

* Schnitttiefe ap ist werkstoffabhängig.

Weitere HM Sorten können Sie in der Sortenübersicht im Kapitel "Technische Hinweise" und der Preisliste finden.

Bestellbeispiel: für rechte Ausführung und Sorte RS07.1841.01/AL41F

* Depth of cut ap is depending on material.

More carbide grades you can find in the grades summary in the chapter "technical instructions" and in the price list.

order-example: righthand version and grade RS07.1841.01/AL41F

MINICUT

Bohrungsbearbeitung

grooving, boring and profiling

Typ Ausdrehen und Kopieren

von gehärteten Teilen mit CBN

D min. 7.8 - 15.5 mm

type boring and profiling,
of hardened parts with CBN

D min. 7.8 - 15.5 mm

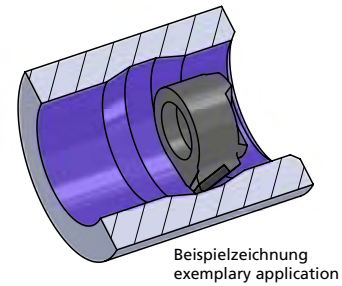
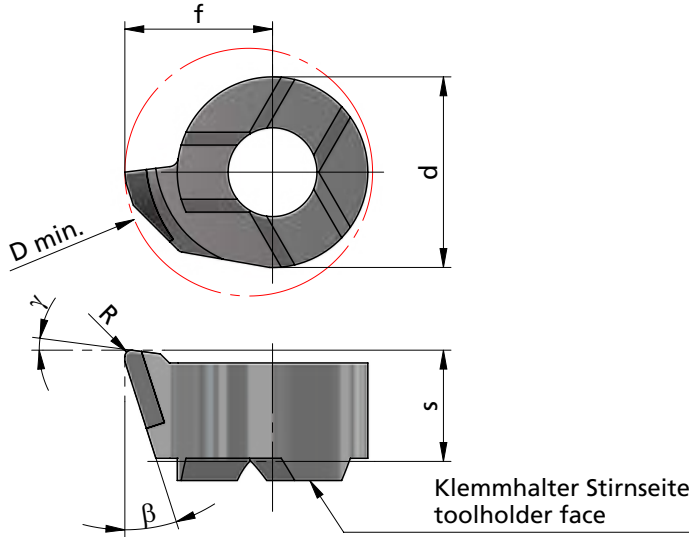

Rechts (R): wie gezeichnet
Links (L): spiegelbildlich

righthand (R): as shown
lefthand version (L): mirror image

Abmessungen in mm

dimensions in mm

Bestellnummer part number	β	γ	R	f	s	d	D min.	CBN	Klemmhalter Typ toolholder type
R/L S08.1846.02/CBN	18°	8°	0.2	4.65	3.5	6	7.8	●	608...
R/L S11.1867.02/CBN	18°	8°	0.2	6.70	4.2	8	11	●	611...
R/L S14.1867.02/CBN	18°	8°	0.2	8.70	5.3	9	13.8	●	614...
R/L S16.1897.02/CBN	18°	8°	0.2	9.70	5.4	11	15.5	●	616...

Weitere HM Sorten können Sie in der Sortenübersicht im Kapitel "Technische Hinweise" und der Preisliste finden.

More carbide grades you can find in the grades summary in the chapter "technical instructions" and in the price list.

Bestellbeispiel:
für rechte Ausführung und Sorte CBN
RS08.1846.02/CBN

order-example:
righthand version and grade CBN
RS08.1846.02/CBN

MINICUT

Bohrungsbearbeitung

grooving, boring and profiling

Typ Ausdrehen und Kopieren

allgemein,
Innenfreistriche DIN 509

D min. 7 - 20 mm

type boring and profiling,
general, undercuts DIN 509

D min. 7 - 20 mm

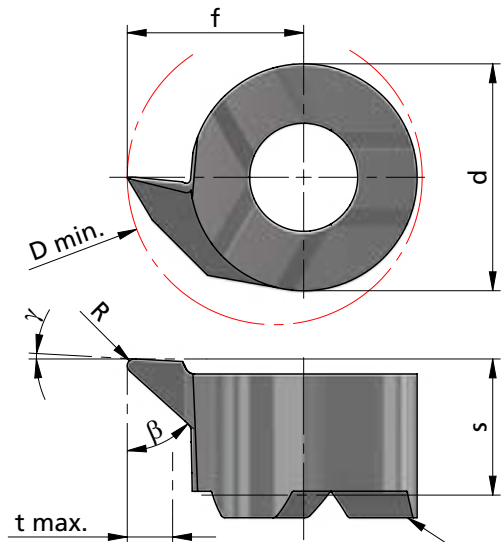

Klemmhalter Stirnseite
toolholder face

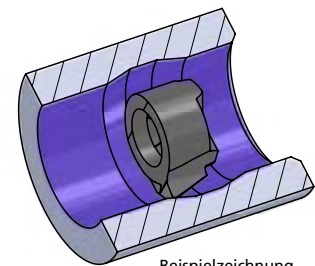

Beispielzeichnung
exemplary application

Rechts (R): wie gezeichnet
Links (L): spiegelbildlich

righthand (R): as shown
lefthand version (L): mirror image

Abmessungen in mm

dimensions in mm

Bestellnummer part number	β	γ	R	f	s	d	t max.	D min.				Klemmhalter Typ toolholder type
									K10F	AL41F	P18C	
R/L S07.4746.02	47°	3°	0.2	4.15	3.7	4.8	1.2	7	●			607...
R/L S08.4746.01	47°	3°	0.1	4.65	3.5	6	1.2	7.8	●			608...
R/L S08.4746.02	47°	3°	0.2	4.65	3.5	6	1.2	7.8	●			608...
R/L S09.4755.02	47°	3°	0.2	5.50	3.5	6.2	1.5	9	●			609...
R/L S11.4767.02	47°	3°	0.2	6.70	4.2	8	2.3	11	●			611...
R/L S14.4787.02	47°	3°	0.2	8.70	5.3	9	4.0	13.7	●			614...
R/L S14.4787.04	47°	3°	0.4	8.70	5.3	9	4.0	13.7	●			614...
R/L S16.4710.02	47°	3°	0.2	10.2	5.4	11	4.3	15.8	●			616...
R/L S18.4712.02	47°	3°	0.2	12.0	5.6	11	6.0	18	●			618...
R/L S20.4714.02	47°	3°	0.2	14.0	5.6	11	8.0	20	●			618...
R/L S08.2555.02	30°	5°	0.2	4.65	3.5	6	1.0	7.8	●	●		608...
R/L S11.2755.02	30°	5°	0.2	6.70	4.2	8	2.3	11	●	●		611...
R/L S14.3555.02	30°	5°	0.2	8.70	5.3	9	4.0	13.7	●			614...
R/L S16.4055.02	30°	5°	0.2	10.2	5.4	11	4.3	15.8	●			616...

Weitere HM Sorten können Sie in der Sortenübersicht im Kapitel "Technische Hinweise" und der Preisliste finden.

More carbide grades you can find in the grades summary in the chapter "technical instructions" and in the price list.

Bestellbeispiel: für rechte Ausführung und Sorte RS07.4746.02/AL41F

order-example: righthand version and grade RS07.4746.02/AL41F

MINICUT

Bohrungsbearbeitung

grooving, boring and profiling

Typ Ausdrehen und Kopieren

Ausdrehen mit spezieller Spantreppe

D min. 7.8 / 9 / 11 mm

type boring and profiling, boring with special chipbreaker

D min. 7.8 / 9 / 11 mm

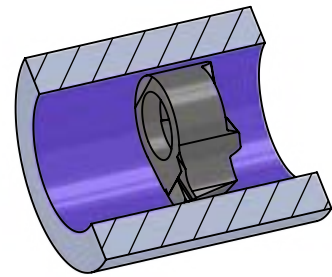
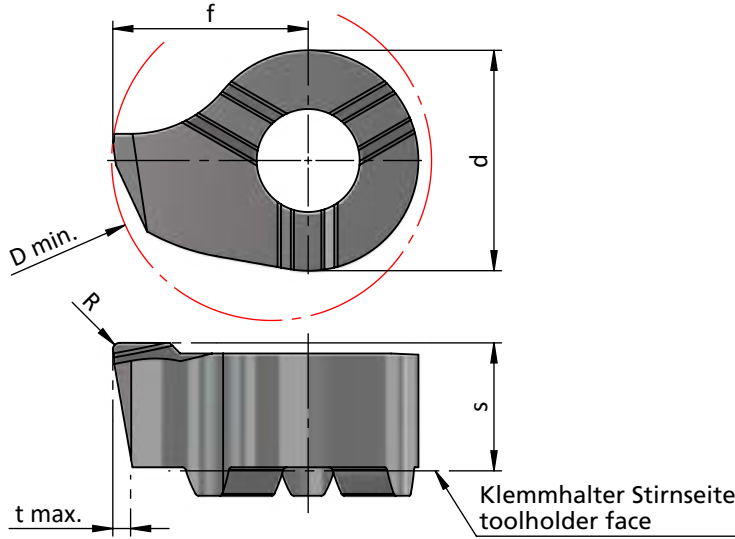

Beispielzeichnung
exemplary application

Rechts (R): wie gezeichnet
Links (L): spiegelbildlich

righthand (R): as shown
lefthand version (L): mirror image

Abmessungen in mm

dimensions in mm

Bestellnummer part number	R	f	s	d	t max.	D min.	Klemmhalter Typ toolholder type			
							K10F	AL41F	P18C	
R/L S08.046C.02	0.2	4.65	3.5	6.0	0.5	7.8	●			608...
R/L S09.055C.02	0.2	5.5	3.6	6.2	0.5	9		●		609...
R/L S11.067C.02	0.2	6.7	4.2	8.0	0.5	11			●	611...

Weitere HM Sorten können Sie in der Sortenübersicht im Kapitel "Technische Hinweise" und der Preisliste finden.

More carbide grades you can find in the grades summary in the chapter "technical instructions" and in the price list.

MINICUT

Bohrungsbearbeitung

grooving, boring and profiling

Typ Ausdrehen und Kopieren

Rückwärtsdrehen

D min. 7.8 - 13.8 mm

type boring and profiling,
backboring

D min. 7.8 - 13.8 mm

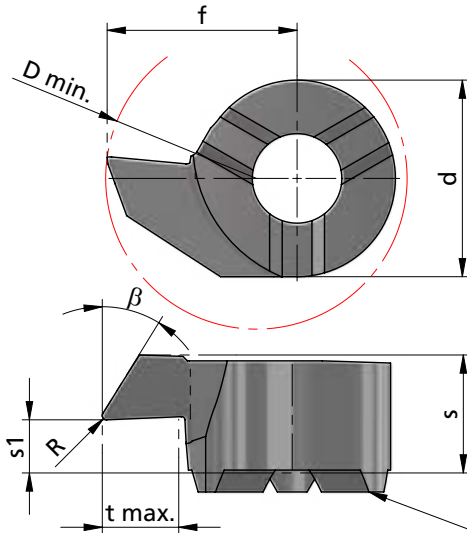

Klemhalter Stirnseite
toolholder face

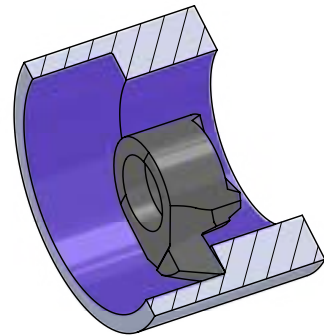

Beispielzeichnung
exemplary application

Rechts (R): wie gezeichnet
Links (L): spiegelbildlich

righthand (R): as shown
lefthand version (L): mirror image

Abmessungen in mm

dimensions in mm

Bestellnummer part number	β	R	f	s	s1	d	t max.	D min.	Klemhalter Typ toolholder type			
									K10F	AL41F	P18C	
R/L S08.3046.02	30°	0.2	4.65	3.3	1.0	6	1.3	7.8	●			608...
R/L S09.3055.02	30°	0.2	5.5	3.7	1.2	6.2	1.7	9		●		609...
R/L S09.3065.02	30°	0.2	6.5	3.7	1.2	6.2	2.3	10		●		609...
R/L S11.3067.02	30°	0.2	6.70	4.3	1.6	8	2.3	11		●		611...
R/L S14.3087.02	30°	0.2	8.70	5.4	2.4	9	3.5	13.8		●		614...

Weitere HM Sorten können Sie in der Sortenübersicht im Kapitel "Technische Hinweise" und der Preisliste finden.

More carbide grades you can find in the grades summary in the chapter "technical instructions" and in the price list.

Bestellbeispiel: für rechte Ausführung und Sorte RS08.3046.02/AL41F

order-example: righthand version and grade RS08.3046.02/AL41F

MINICUT

Bohrungsbearbeitung

grooving, boring and profiling

Impressionen

impressions

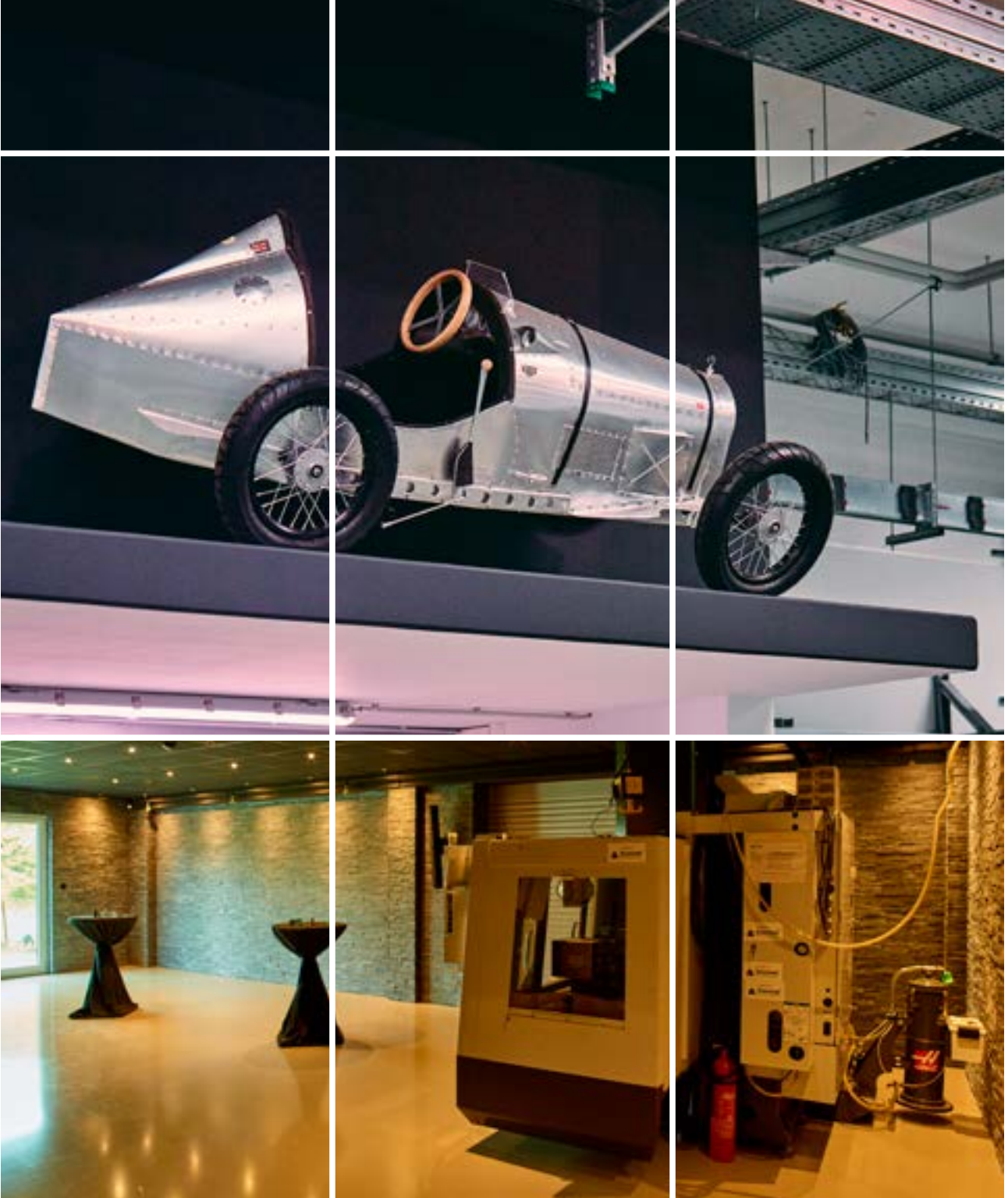
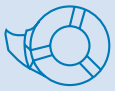

MINICUT

Bohrungsbearbeitung

grooving, boring and profiling

Typ Stechdrehen

Stechdrehen allgemein

type grooving,
general use

D min. 7 / 7.8 mm

D min. 7 / 7.8 mm

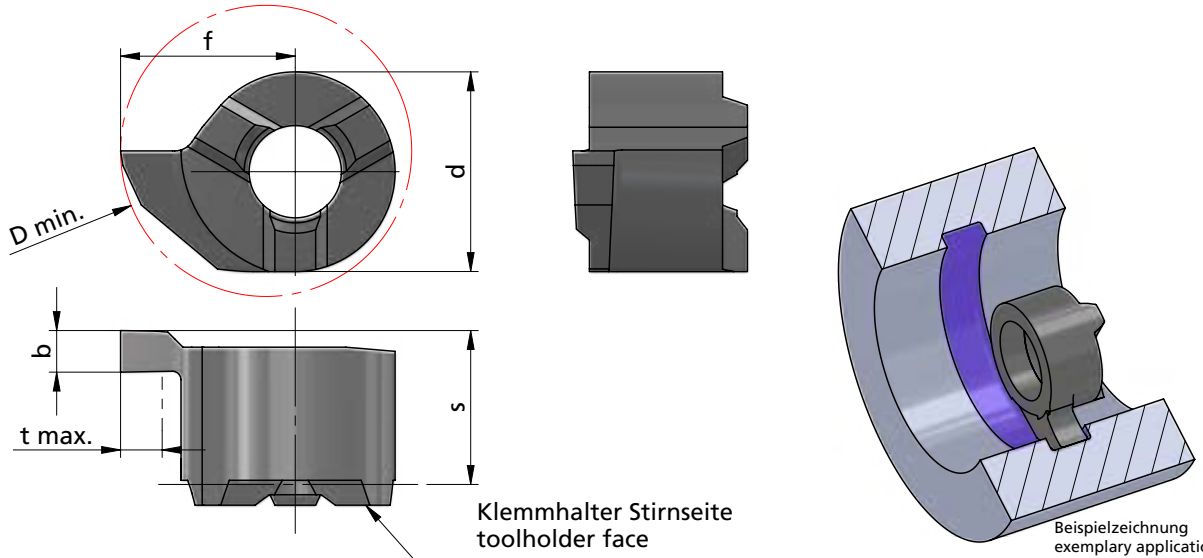

Rechts (R): wie gezeichnet
Links (L): spiegelbildlich

righthand (R): as shown
lefthand version (L): mirror image

Abmessungen in mm

dimensions in mm

Bestellnummer part number	b +0.03	f	s	d	t max.	D min.	Klemmhalter Typ toolholder type		
							K10F	AL41F	P18C
R/L S007.0100	1.0	4.2	3.7	4.8	1.0	7	●		
R/L S007.0150	1.5	4.2	3.7	4.8	1.0	7	●		
R/L S007.0100.8	1.0	5.2	3.7	4.8	2.0	7.8	●		607...
R/L S007.0150.8	1.5	5.2	3.7	4.8	2.0	7.8	●		

Weitere HM Sorten können Sie in der Sortenübersicht im Kapitel "Technische Hinweise" und der Preisliste finden.

Bestellbeispiel:
für rechte Ausführung und Sorte
RS007.0100/AL41F

More carbide grades you can find in the grades summary in the chapter "technical instructions" and in the price list.

order-example:
righthand version and grade
RS007.0100/AL41F

MINICUT

Bohrungsbearbeitung

grooving, boring and profiling

Typ Stechdrehen

für Sicherungsringe DIN 471 / 472
und Stechdrehen allgemein

D min. 8 mm

type grooving,
for circlips DIN 471 / 472
and grooving

D min. 8 mm

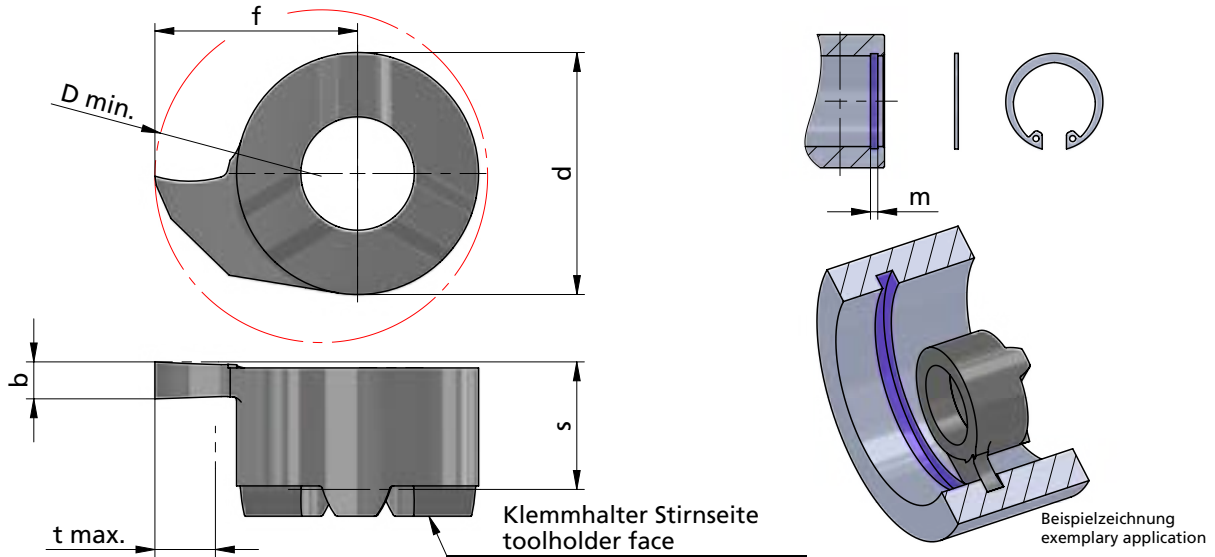

Rechts (R): wie gezeichnet
Links (L): spiegelbildlich

righthand (R): as shown
lefthand version (L): mirror image

Abmessungen in mm

dimensions in mm

Bestellnummer part number	Nut-Maß m groove dim. m DIN 471 / DIN 472	b +0.03	b (inch)	f	s	d	t max.	D min.	Klemmhalter Typ toolholder type			
									K10F	AL41F	P18C	
R/L S008.0070	0.7	0.73		4.8	3.3	6	1.0	8	●			608...
R/L S008.0079	-	0.79	0.031"	4.8	3.3	6	1.0	8		●		
R/L S008.0080	0.8	0.83		4.8	3.3	6	1.0	8		●		
R/L S008.0090	0.9	0.93		4.8	3.3	6	1.0	8		●		
R/L S008.0099	-	0.99	0.039"	4.8	3.3	6	1.0	8		●		
R/L S008.0100	-	1.00		4.8	3.3	6	1.0	8	●	●		
R/L S008.0110	1.1	1.20		4.8	3.3	6	1.0	8	●	●		
R/L S008.0117	-	1.17	0.046"	4.8	3.3	6	1.0	8		●		
R/L S008.0130	1.3	1.40		4.8	3.3	6	1.0	8		●		
R/L S008.0142	-	1.42	0.056"	4.8	3.3	6	1.0	8		●		
R/L S008.0150	-	1.50		4.8	3.3	6	1.0	8		●		
R/L S008.0157	-	1.57	0.062"	4.8	3.3	6	1.0	8		●		
R/L S008.0160	1.6	1.70		4.8	3.3	6	1.0	8		●		
R/L S008.0198	-	1.98	0.078"	4.8	3.3	6	1.0	8		●		
R/L S008.0200	-	2.00		4.8	3.3	6	1.0	8	●	●		

Weitere HM Sorten können Sie in der Sortenübersicht im Kapitel "Technische Hinweise" und der Preisliste finden.

More carbide grades you can find in the grades summary in the chapter "technical instructions" and in the price list.

MINICUT

Bohrungsbearbeitung

grooving, boring and profiling

Typ Stechdrehen

für Sicherungsringe DIN 471 / 472
und Stechdrehen allgemein

D min. 9 mm

type grooving,
for circlips DIN 471 / 472
and grooving

D min. 9 mm

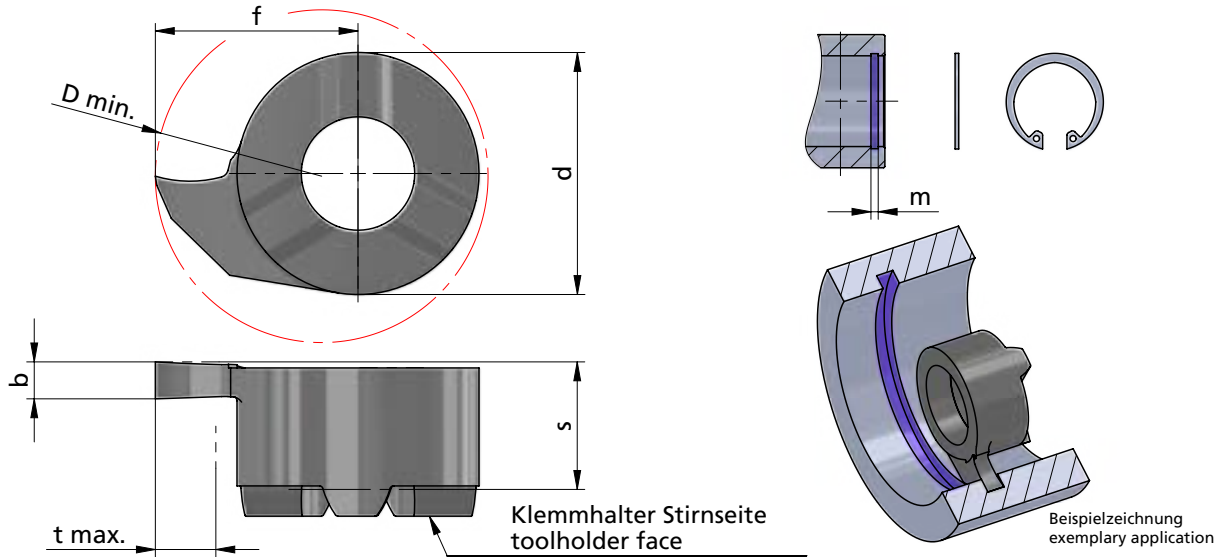

Rechts (R): wie gezeichnet
Links (L): spiegelbildlich

righthand (R): as shown
lefthand version (L): mirror image

Abmessungen in mm

dimensions in mm

Bestellnummer part number	Nut-Maß m groove dim. m DIN 471 / DIN 472	b +0.03	f	s	d	t max.	D min.	Klemmhalter Typ toolholder type		
								K10F	AL41F	P18C
R/L S009.0070	0.7	0.73	5.5	3.4	6.2	1.2	9	●		
R/L S009.0080	0.8	0.83	5.5	3.4	6.2	1.3	9	●		
R/L S009.0090	0.9	0.93	5.5	3.4	6.2	1.5	9	●		
R/L S009.0100	-	1.00	5.5	3.4	6.2	1.8	9	●		
R/L S009.0110	1.1	1.20	5.5	3.6	6.2	1.8	9	●		
R/L S009.0130	1.3	1.40	5.5	3.6	6.2	1.8	9	●		609...
R/L S009.0150	-	1.50	5.5	3.6	6.2	1.8	9	●		
R/L S009.0160	1.6	1.70	5.5	3.6	6.2	1.8	9	●		
R/L S009.0200	-	2.00	5.5	3.6	6.2	1.8	9	●		
R/L S009.0250	-	2.50	5.5	3.6	6.2	1.8	9	●		
R/L S009.0300	-	3.00	5.5	3.6	6.2	1.8	9	●		

Weitere HM Sorten können Sie in der Sortenübersicht im Kapitel "Technische Hinweise" und der Preisliste finden.

Bestellbeispiel:
für rechte Ausführung und Sorte
RS009.0070/AL41F

More carbide grades you can find in the grades summary in the chapter "technical instructions" and in the price list.

order-example:
righthand version and grade
RS009.0070/AL41F

MINICUT

Bohrungsbearbeitung

grooving, boring and profiling

Typ Stechdrehen

für Sicherungsringe DIN 471 / 472
und Stechdrehen allgemein

D min. 11 mm

type grooving,
for circlips DIN 471 / 472
and grooving

D min. 11 mm

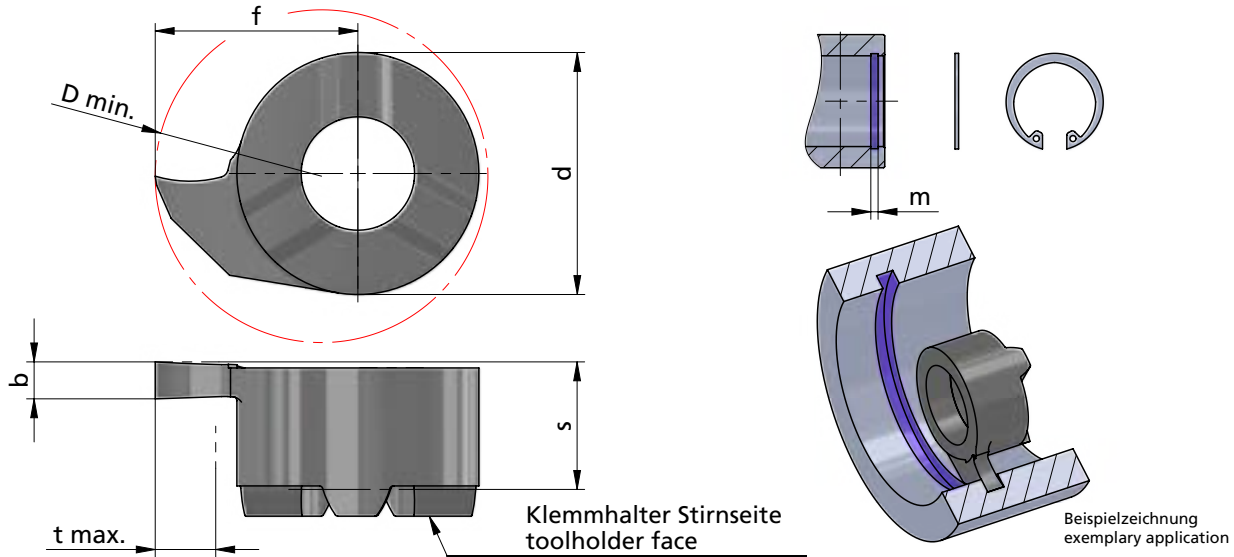

Rechts (R): wie gezeichnet
Links (L): spiegelbildlich

righthand (R): as shown
lefthand version (L): mirror image

Abmessungen in mm

dimensions in mm

Bestellnummer part number	Nut-Maß m groove dim. m DIN 471 / DIN 472	b +0.03	b (inch)	f	s	d	t max.	D min.	K10F	AL41F	P18C	Klemmhalter Typ toolholder type
R/L S011.0070	0.7	0.73		6.7	4.2	8	1.2	11	●			611...
R/L S011.0080	0.8	0.83		6.7	4.2	8	1.3	11		●		
R/L S011.0090	0.9	0.93		6.7	4.2	8	1.5	11		●		
R/L S011.0099	-	0.99	0.039"	6.7	4.2	8	1.5	11		●		
R/L S011.0100	-	1.00		6.7	4.2	8	2.3	11	●	●		
R/L S011.0110	1.1	1.20		6.7	4.2	8	2.3	11	●	●		
R/L S011.0117	-	1.17	0.046"	6.7	4.2	8	2.3	11		●		
R/L S011.0130	1.3	1.40		6.7	4.2	8	2.3	11	●	●		
R/L S011.0150	-	1.50		6.7	4.2	8	2.3	11	●	●		
R/L S011.0157	-	1.57	0.062"	6.7	4.2	8	2.3	11		●		
R/L S011.0160	1.6	1.70		6.7	4.2	8	2.3	11	●	●		
R/L S011.0200	-	2.00		6.7	4.2	8	2.3	11	●	●		
R/L S011.0238	-	2.38	0.094"	6.7	4.2	8	2.3	11		●		
R/L S011.0250	-	2.50		6.7	4.2	8	2.3	11	●	●		
R/L S011.0300	-	3.00		6.7	4.2	8	2.3	11	●	●		

Weitere HM Sorten können Sie in der Sortenübersicht im Kapitel "Technische Hinweise" und der Preisliste finden.

More carbide grades you can find in the grades summary in the chapter "technical instructions" and in the price list.

Bestellbeispiel:
für rechte Ausführung und Sorte
RS011.0070/AL41F

order-example:
righthand version and grade
RS011.0070/AL41F

MINICUT

Bohrungsbearbeitung

grooving, boring and profiling

Typ Stechdrehen

für Sicherungsringe DIN 471 / 472
und Stechdrehen allgemein

type grooving,
for circlips DIN 471 / 472
and grooving

D min. 14 mm

D min. 14 mm

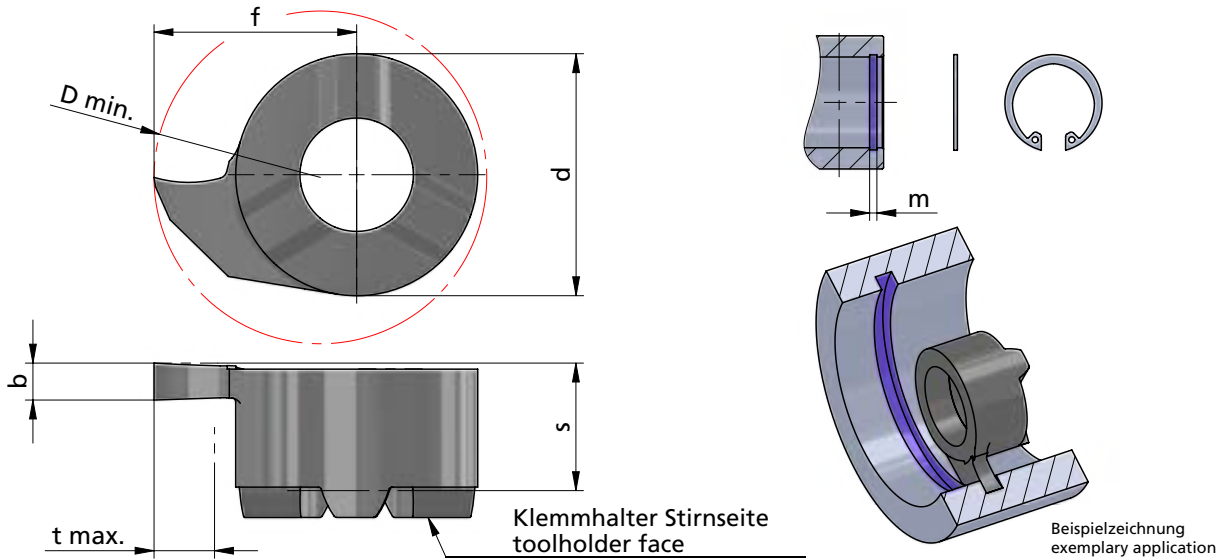

Rechts (R): wie gezeichnet
Links (L): spiegelbildlich

righthand (R): as shown
lefthand version (L): mirror image

Abmessungen in mm

dimensions in mm



Bestellnummer part number	Nut-Maß m groove dim. m DIN 471 / DIN 472	b +0.03	b (inch)	f	s	d	t max.	D min.	K10F	AL41F	P18C	Klemmhalter Typ toolholder type
R/L S014.0070	0.7	0.73		9.0	5.2	9	1.2	14	●			614...
R/L S014.0080	0.8	0.83		9.0	5.2	9	1.3	14		●		
R/L S014.0090	0.9	0.93		9.0	5.2	9	1.5	14	●	●		
R/L S014.0100	-	1.00		9.0	5.2	9	4.0	14		●		
R/L S014.0110	1.1	1.20		9.0	5.3	9	4.0	14	●	●		
R/L S014.0117	-	1.17	0.046"	9.0	5.3	9	4.0	14		●		
R/L S014.0130	1.3	1.40		9.0	5.3	9	4.0	14		●		
R/L S014.0150	-	1.50		9.0	5.3	9	4.0	14	●	●		
R/L S014.0157	-	1.57	0.062"	9.0	5.3	9	4.0	14		●		
R/L S014.0160	1.6	1.70		9.0	5.3	9	4.0	14	●	●		
R/L S014.0200	-	2.00		9.0	5.3	9	4.0	14	●	●		
R/L S014.0238	-	2.38	0.094"	9.0	5.3	9	4.0	14		●		
R/L S014.0250	-	2.50		9.0	5.3	9	4.0	14	●	●		
R/L S014.0300	-	3.00		9.0	5.3	9	4.0	14	●	●		
R/L S014.0318	-	3.18	0.125"	9.0	5.3	9	4.0	14		●		

Weitere HM Sorten können Sie in der Sortenübersicht im Kapitel "Technische Hinweise" und der Preisliste finden.

Bestellbeispiel:
für rechte Ausführung und Sorte
RS014.0070/AL41F

More carbide grades you can find in the grades summary in the chapter "technical instructions" and in the price list.

order-example:
righthand version and grade
RS014.0070/AL41F

MINICUT

Bohrungsbearbeitung

grooving, boring and profiling

Typ Stechdrehen

für Sicherungsringe DIN 471 / 472
und Stechdrehen allgemein

D min. 16 mm

type grooving,
for circlips DIN 471 / 472
and grooving

D min. 16 mm

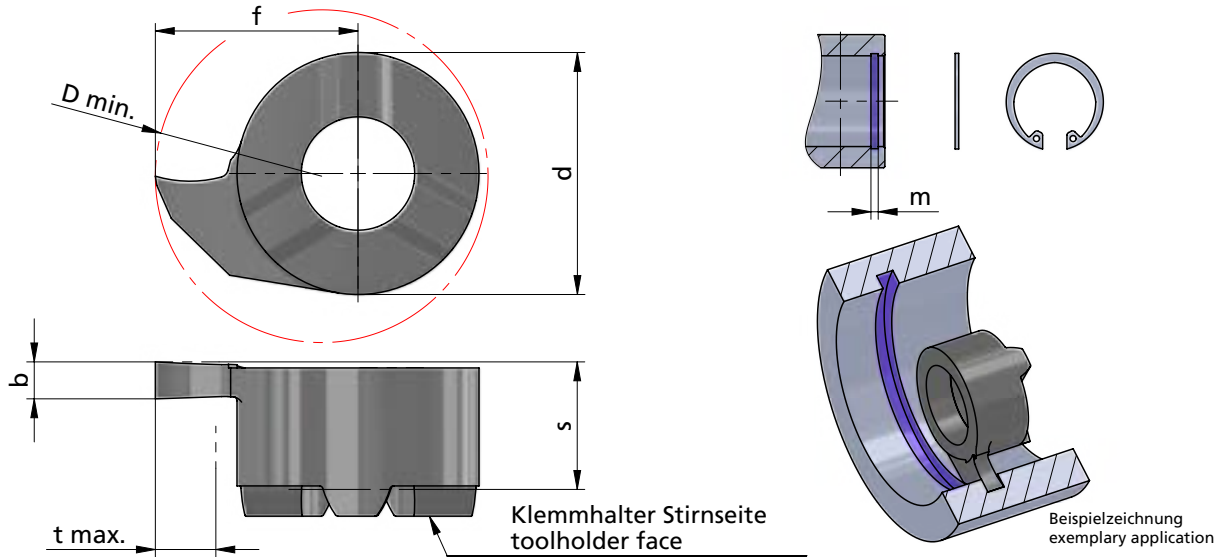

Rechts (R): wie gezeichnet
Links (L): spiegelbildlich

righthand (R): as shown
lefthand version (L): mirror image

Abmessungen in mm

dimensions in mm

Bestellnummer part number	Nut-Maß m groove dim. m DIN 471 / DIN 472	b +0.03	b (inch)	f	s	d	t max.	D min.	K10F	AL41F	P18C	Klemmhalter Typ toolholder type
R/L S016.0070	0.7	0.73		10.2	5.2	11	1.2	16	●			616...
R/L S016.0080	0.8	0.83		10.2	5.2	11	1.3	16		●		
R/L S016.0090	0.9	0.93		10.2	5.2	11	1.5	16		●		
R/L S016.0110	1.1	1.20		10.2	5.4	11	4.3	16	●	●		
R/L S016.0117	-	1.17	0.046"	10.2	5.4	11	4.3	16		●		
R/L S016.0130	1.3	1.40		10.2	5.4	11	4.3	16	●	●		
R/L S016.0150	-	1.50		10.2	5.4	11	4.3	16	●	●		
R/L S016.0157	-	1.57	0.062"	10.2	5.4	11	4.3	16		●		
R/L S016.0160	1.6	1.70		10.2	5.4	11	4.3	16	●	●		
R/L S016.0185	1.85	1.95		10.2	5.4	11	4.3	16	●	●		
↳ ...												

Weitere HM Sorten können Sie in der Sortenübersicht im Kapitel "Technische Hinweise" und der Preisliste finden.

More carbide grades you can find in the grades summary in the chapter "technical instructions" and in the price list.

Bestellbeispiel:
für rechte Ausführung und Sorte
RS016.0070/AL41F

order-example:
righthand version and grade
RS016.0070/AL41F

MINICUT

Bohrungsbearbeitung

grooving, boring and profiling

Typ Stechdrehen

für Sicherungsringe DIN 471 / 472
und Stechdrehen allgemein

type grooving,
for circlips DIN 471 / 472
and grooving

D min. 16 mm

D min. 16 mm

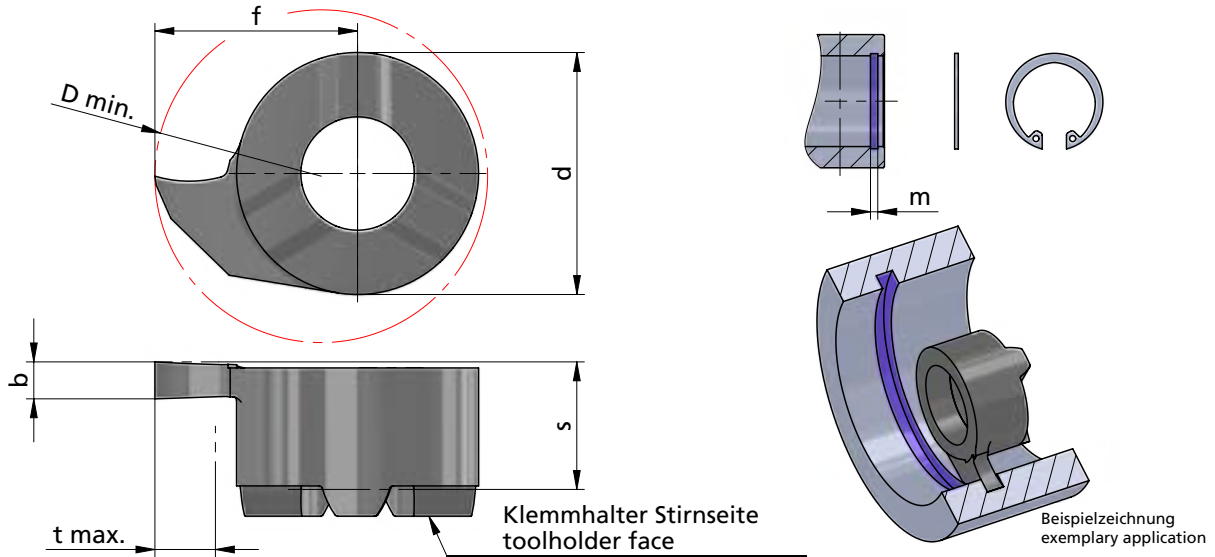

Rechts (R): wie gezeichnet
Links (L): spiegelbildlich

righthand (R): as shown
lefthand version (L): mirror image

Abmessungen in mm

dimensions in mm

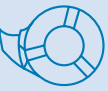

Bestellnummer part number	Nut-Maß m groove dim. m DIN 471 / DIN 472	b +0.03	b (inch)	f	s	d	t max.	D min.	Klemmhalter Typ toolholder type			
									K10F	AL41F	P18C	
⋮ ↙												
R/L S016.0200	-	2.00		10.2	5.4	11	4.3	16	●	●		616...
R/L S016.0215	2.15	2.25		10.2	5.4	11	4.3	16	●	●		
R/L S016.0238	-	2.38	0.094"	10.2	5.4	11	4.3	16		●		
R/L S016.0250	-	2.50		10.2	5.4	11	4.3	16	●	●		
R/L S016.0265	2.65	2.75		10.2	5.4	11	4.3	16	●	●		
R/L S016.0300	-	3.00		10.2	5.4	11	4.3	16	●	●		
R/L S016.0315	3.15	3.28		10.2	5.4	11	4.3	16	●	●		
R/L S016.0350	-	3.50		10.2	5.4	11	4.3	16		●		
R/L S016.0400	-	4.00		10.2	5.4	11	4.3	16		●		
R/L S016.0415	4.15	4.28		10.2	5.4	11	4.3	16	●	●		

Weitere HM Sorten können Sie in der Sortenübersicht im Kapitel "Technische Hinweise" und der Preisliste finden.

Bestellbeispiel:
für rechte Ausführung und Sorte
RS016.0200/AL41F

More carbide grades you can find in the grades summary in the chapter "technical instructions" and in the price list.

order-example:
righthand version and grade
RS016.0200/AL41F

MINICUT

Bohrungsbearbeitung

grooving, boring and profiling

Typ Stechdrehen

Stechdrehen allgemein

type grooving,
general use

D min. 18 / 20 mm

D min. 18 / 20 mm

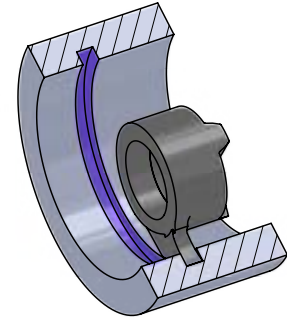
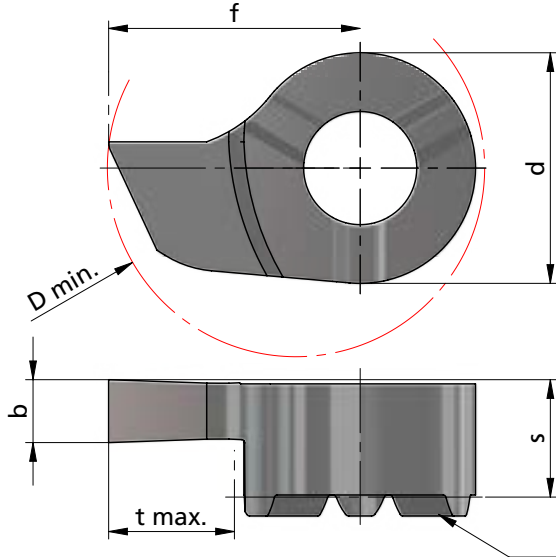

Klemhalter Stirnseite
toolholder face

Beispielzeichnung
exemplary application

Rechts (R): wie gezeichnet
Links (L): spiegelbildlich

righthand (R): as shown
lefthand version (L): mirror image

Abmessungen in mm

dimensions in mm

Bestellnummer part number	b +0.03	f	s	d	t max.	D min.	Klemhalter Typ toolholder type		
							K10F	AL41F	P18C
R/L S18.0150.00	1.5	12	5.6	11	6.0	18	●	●	618...
R/L S18.0200.00	2.0	12	5.6	11	6.0	18	●	●	
R/L S18.0250.00	2.5	12	5.6	11	6.0	18	●	●	
R/L S18.0300.00	3.0	12	5.6	11	6.0	18	●	●	
R/L S18.0350.00	3.5	12	5.6	11	6.0	18	●	●	
R/L S18.0400.00	4.0	12	5.6	11	6.0	18	●	●	
R/L S20.0150.00	1.5	14	5.6	11	8.0	20	●	●	
R/L S20.0200.00	2.0	14	5.6	11	8.0	20	●	●	
R/L S20.0250.00	2.5	14	5.6	11	8.0	20	●	●	
R/L S20.0300.00	3.0	14	5.6	11	8.0	20	●	●	
R/L S20.0350.00	3.5	14	5.6	11	8.0	20	●	●	
R/- S20.0400.00	4.0	14	5.6	11	8.0	20	●	●	

Weitere HM Sorten können Sie in der Sortenübersicht im Kapitel "Technische Hinweise" und der Preisliste finden.

More carbide grades you can find in the grades summary in the chapter "technical instructions" and in the price list.

Bestellbeispiel:
für rechte Ausführung und Sorte
RS20.0150.00/AL41F

order-example:
righthand version and grade
RS20.0150.00/AL41F

MINICUT

Bohrungsbearbeitung

grooving, boring and profiling

Typ Stechdrehen

Stechdrehen allgemein,
große Einstechtiefe

type grooving, general use,
maximum depth of groove

D min. 16 / 17 mm

D min. 16 / 17 mm

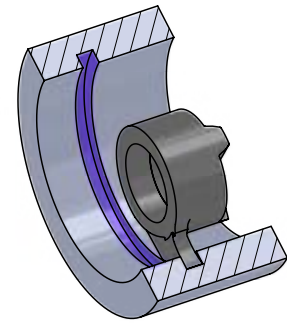
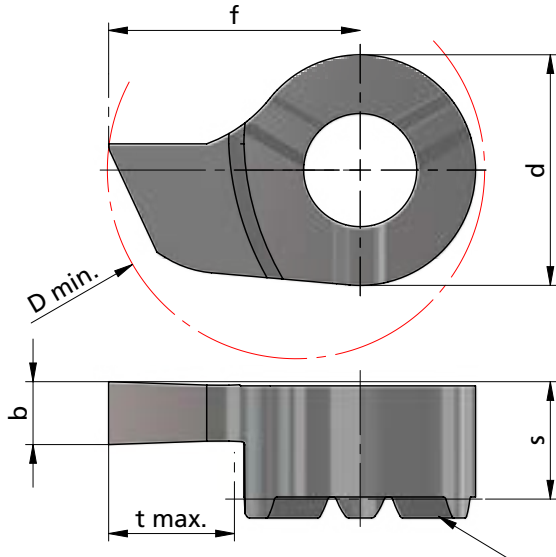

Klemhalter Stirnseite
toolholder face

Beispielzeichnung
exemplary application

Rechts (R): wie gezeichnet
Links (L): spiegelbildlich

righthand (R): as shown
lefthand version (L): mirror image

Abmessungen in mm

dimensions in mm

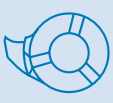

Bestellnummer part number	b +0.03	f	s	d	t max.	D min.	Klemmhalter Typ toolholder type			
							K10F	AL41F	P18C	
R/L S55.150.00	1.5	10.5	5.0	9	5.5	16		●		614...
R/L S55.200.00	2.0	10.5	5.2	9	5.5	16	●	●		
R/L S55.250.00	2.5	10.5	5.2	9	5.5	16		●		
R/L S55.300.00	3.0	10.5	5.2	9	5.5	16		●		
R/L S65.150.00	1.5	11.5	5.0	9	6.5	17		●		
R/L S65.200.00	2.0	11.5	5.2	9	6.5	17		●		
R/L S65.250.00	2.5	11.5	5.2	9	6.5	17		●		
R/L S65.300.00	3.0	11.5	5.2	9	6.5	17		●		

Weitere HM Sorten können Sie in der Sortenübersicht im Kapitel "Technische Hinweise" und der Preisliste finden.

Bestellbeispiel:
für rechte Ausführung und Sorte
RS55.150.00/AL41F

More carbide grades you can find in the grades summary in the chapter "technical instructions" and in the price list.

order-example:
righthand version and grade
RS55.150.00/AL41F

MINICUT

Bohrungsbearbeitung

grooving, boring and profiling

Typ Stechdrehen

NC-Feindrehen

type grooving,
NC-profiling

D min. 7.8 - 20 mm

D min. 7.8 - 20 mm

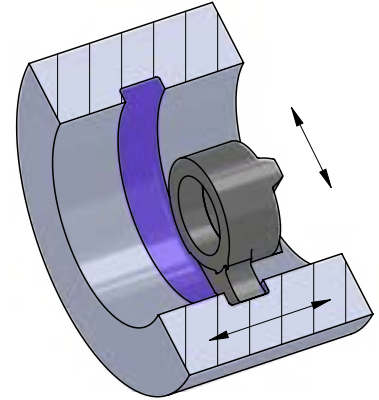
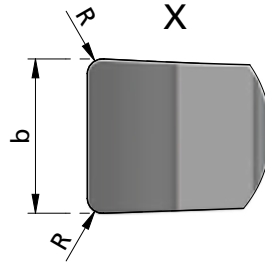
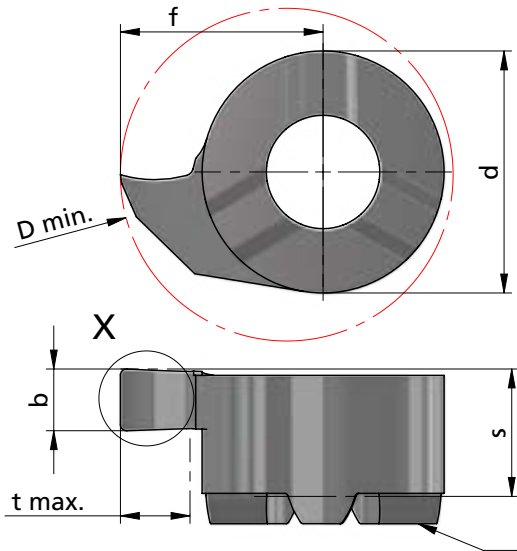

Klemmhalter Stirnseite
toolholder face

Beispielzeichnung
exemplary application

Rechts (R): wie gezeichnet
Links (L): spiegelbildlich

righthand (R): as shown
lefthand version (L): mirror image

Abmessungen in mm

dimensions in mm

Bestellnummer part number	b		R	f	s	d	ap *	t max.	D min.	K10F AL41F P18C	Klemmhalter Typ toolholder type
	+0.03	(inch)									
R/L S07.150.02.8	1.5		0.2	5.2	3.7	4.8	0.2	2.0	7.8	●	607...
R/L S08.079.02	0.79	0.031"	0.2	4.8	3.3	6	0.2	1.0	8	●	608...
R/L S08.117.02	1.17	0.046"	0.2	4.8	3.3	6	0.2	1.0	8	●	
R/L S08.150.02	1.50		0.2	4.8	3.3	6	0.2	1.0	8	●	
R/L S08.157.02	1.57	0.062"	0.2	4.8	3.3	6	0.2	1.0	8	●	
R/L S08.198.02	1.98	0.078"	0.2	4.8	3.3	6	0.2	1.0	8	●	
R/L S08.200.02	2.00		0.2	4.8	3.3	6	0.2	1.0	8	●	
R/L S09.150.02	1.50		0.2	5.5	3.6	6.2	0.2	1.8	9	●	609...
R/L S09.200.02	2.00		0.2	5.5	3.6	6.2	0.2	1.8	9	●	
R/L S09.150.02.10	1.50		0.2	6.5	3.6	6.2	0.2	2.8	10	●	
R/L S09.200.02.10	2.00		0.2	6.5	3.6	6.2	0.2	2.8	10	●	
↳ ...											

* Schnitttiefe ap ist werkstoffabhängig.

Weitere HM Sorten können Sie in der Sortenübersicht im Kapitel "Technische Hinweise" und der Preisliste finden.

Bestellbeispiel: für rechte Ausführung und Sorte RS07.150.02.8/AL41F

* Depth of cut ap is depending on material.

More carbide grades you can find in the grades summary in the chapter "technical instructions" and in the price list.

order-example: righthand version and grade RS07.150.02.8/AL41F

MINICUT

Bohrungsbearbeitung

grooving, boring and profiling

Typ Stechdrehen

NC-Feindrehen

type grooving,
NC-profiling

D min. 7.8 - 20 mm

D min. 7.8 - 20 mm

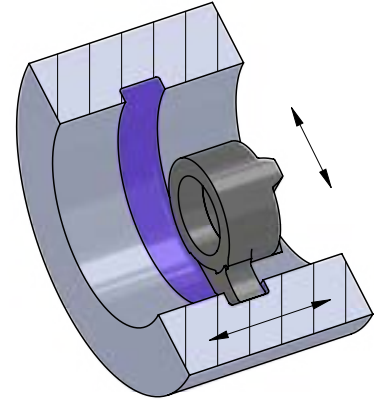
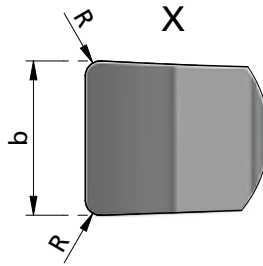
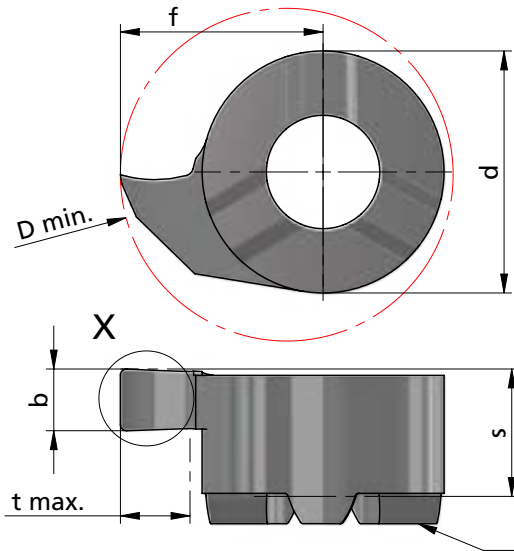

Klemhalter Stirnseite
toolholder face

Beispielzeichnung
exemplary application

Rechts (R): wie gezeichnet
Links (L): spiegelbildlich

righthand (R): as shown
lefthand version (L): mirror image

Abmessungen in mm

dimensions in mm

Bestellnummer part number	b		R	f	s	d	ap *	t max.	D min.	K10F AL41F P18C	Klemhalter Typ toolholder type
	+0.03	(inch)									
⋮ ↙											
R/L S11.079.02	0.79	0.031"	0.2	6.7	4.2	8	0.2	2.3	11	●	611...
R/L S11.100.02	1.00		0.2	6.7	4.2	8	0.2	2.3	11	●	
R/L S11.117.02	1.17	0.046"	0.2	6.7	4.2	8	0.2	2.3	11	●	
R/L S11.150.02	1.50		0.2	6.7	4.2	8	0.2	2.3	11	●	
R/L S11.157.02	1.57	0.062"	0.2	6.7	4.2	8	0.2	2.3	11	●	
R/L S11.198.02	1.98	0.078"	0.2	6.7	4.2	8	0.2	2.3	11	●	
R/L S11.200.02	2.00		0.2	6.7	4.2	8	0.2	2.3	11	●	
R/L S11.238.02	2.38	0.094"	0.2	6.7	4.2	8	0.2	2.3	11	●	
R/L S11.318.02	3.18	0.125"	0.2	6.7	4.2	8	0.2	2.3	11	●	
↘ ...											

* Schnitttiefe ap ist werkstoffabhängig.

Weitere HM Sorten können Sie in der Sortenübersicht im Kapitel "Technische Hinweise" und der Preisliste finden.

Bestellbeispiel: für rechte Ausführung und Sorte RS11.079.02/AL41F

* Depth of cut ap is depending on material.

More carbide grades you can find in the grades summary in the chapter "technical instructions" and in the price list.

order-example: righthand version and grade RS11.079.02/AL41F

MINICUT

Bohrungsbearbeitung

grooving, boring and profiling

Typ Stechdrehen

NC-Feindrehen

type grooving,
NC-profiling

D min. 7.8 - 20 mm

D min. 7.8 - 20 mm

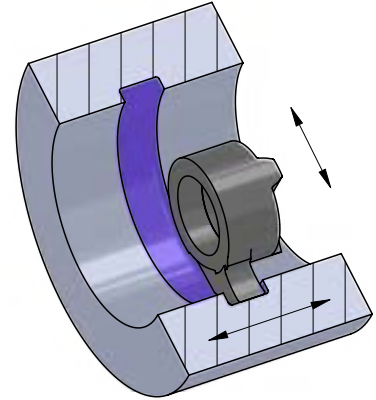
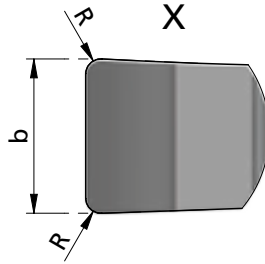
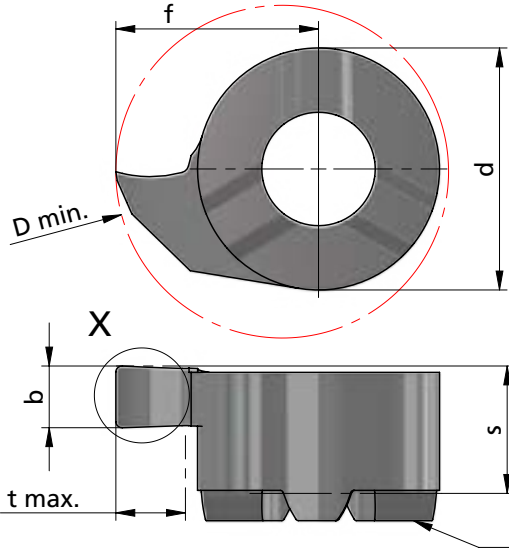

Klemhalter Stirnseite
toolholder face

Beispielzeichnung
exemplary application

Rechts (R): wie gezeichnet
Links (L): spiegelbildlich

righthand (R): as shown
lefthand version (L): mirror image

Abmessungen in mm

dimensions in mm

Bestellnummer part number	b +0.03	b (inch)	R	f	s	d	ap *	t max.	D min.	Klemhalter Typ toolholder type		
										K10F	AL41F	P18C
↙ ↘												
R/L S14.150.02	1.50		0.2	9.0	5.3	9	0.2	4.0	14	●	●	614...
R/L S14.157.02	1.57	0.062"	0.2	9.0	5.3	9	0.2	4.0	14		●	
R/L S14.157.04	1.57	0.062"	0.4	9.0	5.3	9	0.2	4.0	14		●	
R/L S14.200.02	2.00		0.2	9.0	5.3	9	0.2	4.0	14	●	●	
R/L S14.238.02	2.38	0.094"	0.2	9.0	5.3	9	0.2	4.0	14		●	
R/L S14.250.02	2.50		0.2	9.0	5.3	9	0.2	4.0	14		●	
R/L S14.318.02	3.18	0.125"	0.2	9.0	5.3	9	0.2	4.0	14		●	
R/L S16.157.02	1.57	0.062"	0.2	10.2	5.4	11	0.2	4.3	16		●	616...
R/L S16.200.02	2.00		0.2	10.2	5.4	11	0.2	4.3	16		●	
R/L S16.318.02	3.18	0.125"	0.2	10.2	5.4	11	0.2	4.3	16		●	
↘ ↙												

* Schnitttiefe ap ist werkstoffabhängig.

Weitere HM Sorten können Sie in der Sortenübersicht im Kapitel "Technische Hinweise" und der Preisliste finden.

Bestellbeispiel: für rechte Ausführung und Sorte RS14.150.02/AL41F

* Depth of cut ap is depending on material.

More carbide grades you can find in the grades summary in the chapter "technical instructions" and in the price list.

order-example: righthand version and grade RS14.150.02/AL41F

MINICUT

Bohrungsbearbeitung

grooving, boring and profiling

Typ Stechdrehen

NC-Feindrehen

type grooving,
NC-profiling

D min. 7.8 - 20 mm

D min. 7.8 - 20 mm

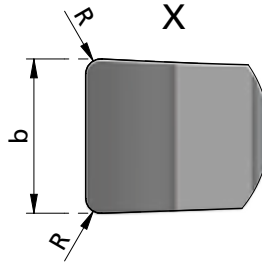
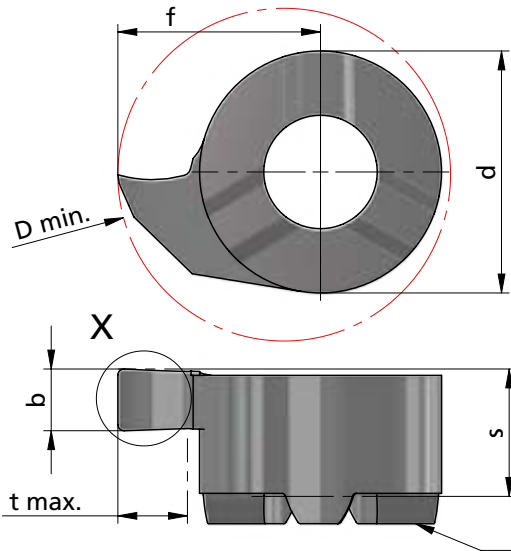

Klemmhalter Stirnseite
toolholder face

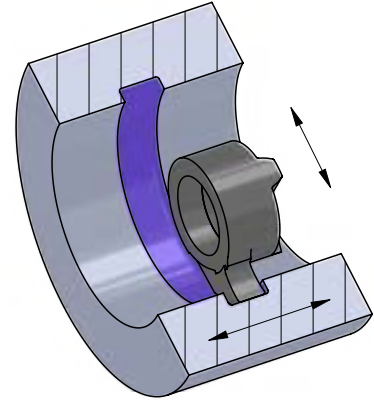

Beispielzeichnung
exemplary application

Rechts (R): wie gezeichnet
Links (L): spiegelbildlich

righthand (R): as shown
lefthand version (L): mirror image

Abmessungen in mm

dimensions in mm

Bestellnummer part number	b +0.03	b (inch)	R	f	s	d	ap *	t max.	D min.	Material			Klemmhalter Typ toolholder type
										K10F	AL41F	P18C	
R/L S18.200.02	2.00		0.2	12	5.6	11	0.2	6.0	18		●		618...
R/L S20.150.02	1.50		0.2	14	5.6	11	0.2	8.0	20		●		618...
R/L S20.200.02	2.00		0.2	14	5.6	11	0.2	8.0	20		●		
R/L S20.250.02	2.50		0.2	14	5.6	11	0.2	8.0	20		●		
R/L S20.300.02	3.00		0.2	14	5.6	11	0.2	8.0	20		●		
R/L S20.400.02	4.00		0.2	14	5.6	11	0.2	8.0	20		●		

* Schnitttiefe ap ist werkstoffabhängig.

Weitere HM Sorten können Sie in der Sortenübersicht im Kapitel "Technische Hinweise" und der Preisliste finden.

Bestellbeispiel: für rechte Ausführung und Sorte RS18.200.02/AL41F

* Depth of cut ap is depending on material.

More carbide grades you can find in the grades summary in the chapter "technical instructions" and in the price list.

order-example: righthand version and grade RS18.200.02/AL41F

MINICUT

Bohrungsbearbeitung

grooving, boring and profiling

Typ Stechdrehen

NC-Feindrehen,
große Einstechtiefe

D min. 16 / 17 mm

type grooving,
NC-profiling,
maximum depth of groove

D min. 16 / 17 mm

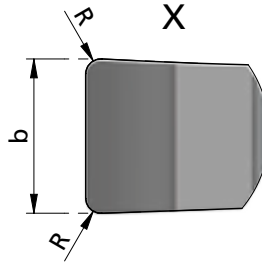
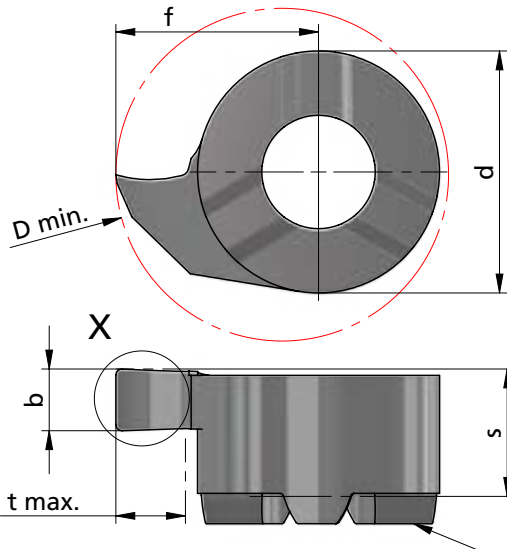

Klemmhalter Stirnseite
toolholder face

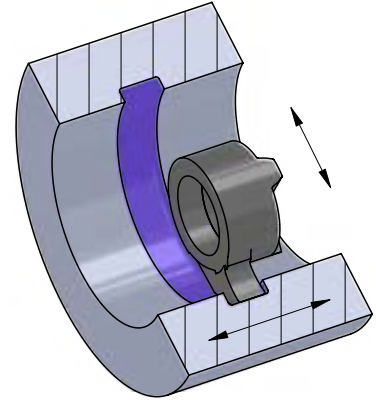

Beispielzeichnung
exemplary application

Rechts (R): wie gezeichnet
Links (L): spiegelbildlich

righthand (R): as shown
lefthand version (L): mirror image

Abmessungen in mm

dimensions in mm

Bestellnummer part number	b +0.03	R	f	s	d	t max.	D min.	Klemmhalter Typ toolholder type			
								K10F	AL41F	P18C	
R/L S55.150.02	1.5	0.2	10.5	5.2	9	5.5	16	●	●	●	614...
R/L S55.200.02	2.0	0.2	10.5	5.2	9	5.5	16	●	●	●	
R/L S55.250.02	2.5	0.2	10.5	5.2	9	5.5	16	●	●	●	
R/L S55.300.02	3.0	0.2	10.5	5.2	9	5.5	16	●	●	●	
R/L S65.150.02	1.5	0.2	11.5	5.2	9	6.5	17	●	●	●	
R/L S65.200.02	2.0	0.2	11.5	5.2	9	6.5	17	●	●	●	
R/L S65.250.02	2.5	0.2	11.5	5.2	9	6.5	17	●	●	●	
R/L S65.300.02	3.0	0.2	11.5	5.2	9	6.5	17	●	●	●	

Weitere HM Sorten können Sie in der Sortenübersicht im Kapitel "Technische Hinweise" und der Preisliste finden.

More carbide grades you can find in the grades summary in the chapter "technical instructions" and in the price list.

Bestellbeispiel:
für rechte Ausführung und Sorte
RS55.150.02/AL41F

order-example:
righthand version and grade
RS55.150.02/AL41F

MINICUT

Bohrungsbearbeitung

grooving, boring and profiling

Typ Stechdrehen

Stechdrehen und Kopieren
Vollradius

type grooving,
grooving and profiling
full radius

D min. 8 - 16 mm
Vollradius R 0.4 - 2.0

D min. 8 - 16 mm
full radius R 0.4 - 2.0

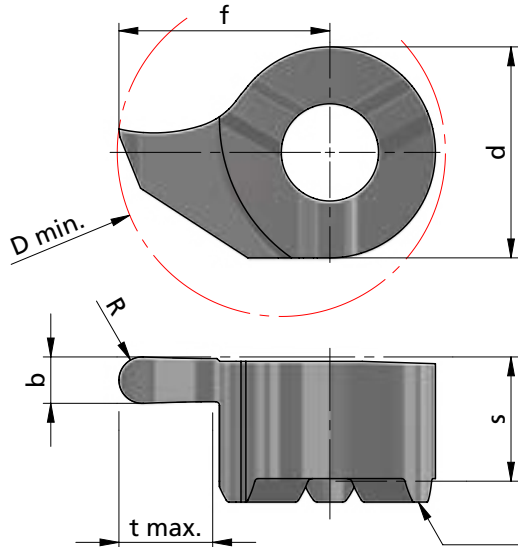

Klemmhalter Stirnseite
toolholder face

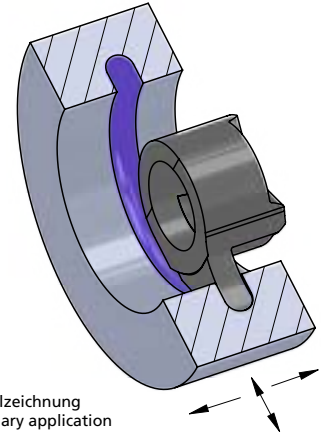

Beispielzeichnung
exemplary application

Rechts (R): wie gezeichnet
Links (L): spiegelbildlich

righthand (R): as shown
lefthand version (L): mirror image

Abmessungen in mm

dimensions in mm



Bestellnummer part number	b +0.05	b (inch)	R	f	s	d	t max.	D min.				Klemmhalter Typ toolholder type
									K10F	AL41F	P18C	
R/L S08.008R04	0.80		0.40	4.8	3.3	6.0	1.0	8	●	●		
R/L S08.012R06	1.20		0.60	4.8	3.3	6.0	1.0	8		●		
R/L S08.U15R08	1.57	0.062"	0.78	4.8	3.3	6.0	1.0	8		●		608...
R/L S08.018R09	1.80		0.90	4.8	3.3	6.0	1.0	8	●	●		
R/L S08.020R10	2.00		1.00	4.8	3.3	6.0	1.0	8		●		
R/L S09.008R04	0.80		0.40	5.5	3.5	6.2	1.6	9		●		
R/L S09.010R05	1.00		0.50	5.5	3.5	6.2	1.6	9		●		
R/L S09.012R06	1.20		0.60	5.5	3.5	6.2	1.6	9		●		609...
R/L S09.018R09	1.80		0.90	5.5	3.5	6.2	1.6	9		●		
R/L S09.020R10	2.00		1.00	5.5	3.5	6.2	1.6	9		●		
↳ ...												

Weitere HM Sorten können Sie in der Sortenübersicht im Kapitel "Technische Hinweise" und der Preisliste finden.

Bestellbeispiel:
für rechte Ausführung und Sorte
RS08.008R04/AL41F

More carbide grades you can find in the grades summary in the chapter "technical instructions" and in the price list.

order-example:
righthand version and grade
RS08.008R04/AL41F

MINICUT

Bohrungsbearbeitung

grooving, boring and profiling

Typ Stechdrehen

Stechdrehen und Kopieren
Vollradius

type grooving,
grooving and profiling
full radius

D min. 8 - 16 mm
Vollradius R 0.4 - 2.0

D min. 8 - 16 mm
full radius R 0.4 - 2.0

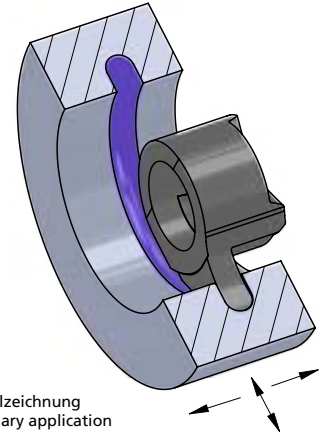
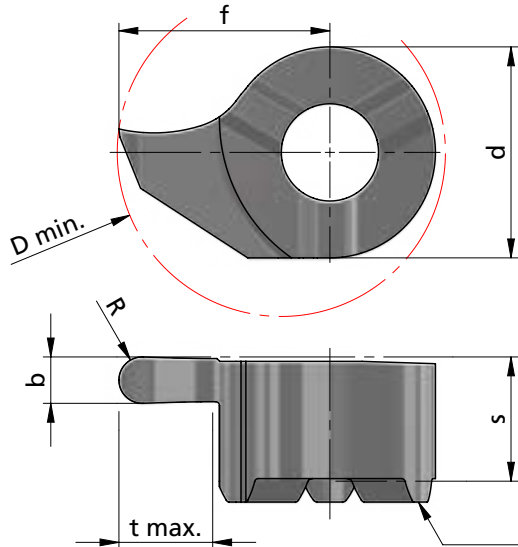

Rechts (R): wie gezeichnet
Links (L): spiegelbildlich

righthand (R): as shown
lefthand version (L): mirror image

Abmessungen in mm

dimensions in mm

Bestellnummer part number	b +0.05	b (inch)	R	f	s	d	t max.	D min.				Klemmhalter Typ toolholder type
									K10F	AL41F	P18C	
⋮ ↙												
R/L S11.008R04	0.80		0.40	6.7	4.2	8	2.3	11	●	●		611...
R/L S11.U11R05	1.17	0.046"	0.58	6.7	4.2	8	2.3	11	●	●		
R/L S11.012R06	1.20		0.60	6.7	4.2	8	2.3	11	●	●		
R/L S11.U15R08	1.57	0.062"	0.79	6.7	4.2	8	2.3	11	●	●		
R/L S11.016R08	1.60		0.80	6.7	4.2	8	2.3	11		●		
R/L S11.018R09	1.80		0.90	6.7	4.2	8	2.3	11		●		
R/L S11.020R10	2.00		1.00	6.7	4.2	8	2.3	11	●	●		
R/L S11.024R12	2.40		1.20	6.7	4.2	8	2.3	11		●		
R/L S11.030R15	3.00		1.50	6.7	4.2	8	2.3	11	●	●		
↘ ...												

Weitere HM Sorten können Sie in der Sortenübersicht im Kapitel "Technische Hinweise" und der Preisliste finden.

More carbide grades you can find in the grades summary in the chapter "technical instructions" and in the price list.

MINICUT

Bohrungsbearbeitung

grooving, boring and profiling

Typ Stechdrehen

Stechdrehen und Kopieren
Vollradius

type grooving,
grooving and profiling
full radius

D min. 8 - 16 mm
Vollradius R 0.4 - 2.0

D min. 8 - 16 mm
full radius R 0.4 - 2.0

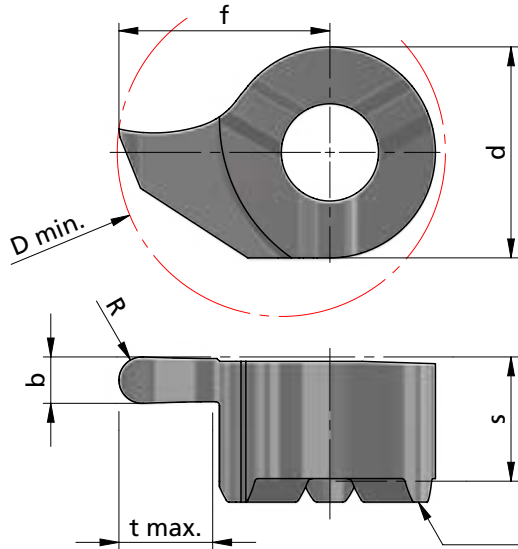

Klemmhalter Stirnseite
toolholder face

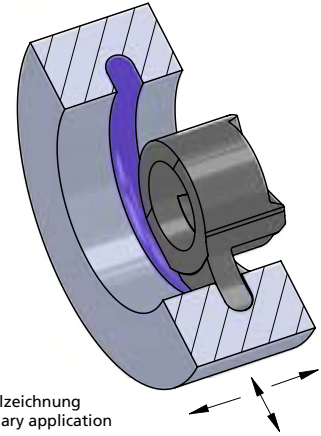

Beispielzeichnung
exemplary application

Rechts (R): wie gezeichnet
Links (L): spiegelbildlich

righthand (R): as shown
lefthand version (L): mirror image

Abmessungen in mm

dimensions in mm

Bestellnummer part number	b +0.05	b (inch)	R	f	s	d	t max.	D min.	Klemmhalter Typ toolholder type		
									K10F	AL41F	P18C
⋮ ↙											
R/L S14.008R04	0.80		0.40	9.0	5.2	9	4.0	14	●		
R/L S14.010R05	1.00		0.50	9.0	5.3	9	4.0	14	●		
R/L S14.012R06	1.20		0.60	9.0	5.3	9	4.0	14	●		
R/L S14.U15R08	1.57	0.062"	0.78	9.0	5.3	9	4.0	14	●		614...
R/L S14.018R09	1.80		0.90	9.0	5.3	9	4.0	14	●		
R/L S14.020R10	2.00		1.00	9.0	5.3	9	4.0	14	●		
R/L S14.022R11	2.20		1.10	9.0	5.3	9	4.0	14	●		
R/L S14.030R15	3.00		1.50	9.0	5.3	9	4.0	14	●	●	
↙ ...											

Weitere HM Sorten können Sie in der Sortenübersicht im Kapitel "Technische Hinweise" und der Preisliste finden.

Bestellbeispiel:
für rechte Ausführung und Sorte
RS14.008R04/AL41F

More carbide grades you can find in the grades summary in the chapter "technical instructions" and in the price list.

order-example:
righthand version and grade
RS14.008R04/AL41F

MINICUT

Bohrungsbearbeitung

grooving, boring and profiling

Typ Stechdrehen

Stechdrehen und Kopieren
Vollradius

type grooving,
grooving and profiling
full radius

D min. 8 - 16 mm
Vollradius R 0.4 - 2.0

D min. 8 - 16 mm
full radius R 0.4 - 2.0

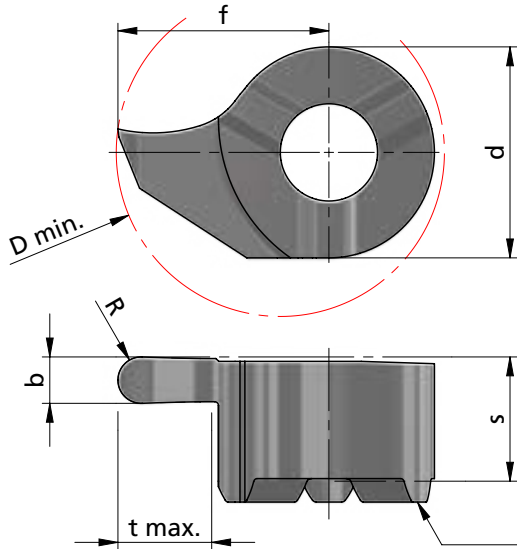

Klemmhalter Stirnseite
toolholder face

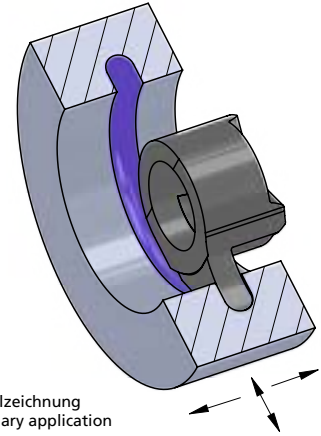

Rechts (R): wie gezeichnet
Links (L): spiegelbildlich

righthand (R): as shown
lefthand version (L): mirror image

Abmessungen in mm

dimensions in mm

Bestellnummer part number	b +0.05	b (inch)	R	f	s	d	t max.	D min.	Klemmhalter Typ toolholder type		
									K10F	AL41F	P18C
⋮ ↙											
R/L S16.016R08	1.60		0.80	10.2	5.4	11	4.3	16	●		
R/L S16.018R09	1.80		0.90	10.2	5.4	11	4.3	16	●		
R/L S16.U19R09	1.98	0.078"	0.99	10.2	5.4	11	4.3	16	●		
R/L S16.020R10	2.00		1.00	10.2	5.4	11	4.3	16	●		
R/L S16.022R11	2.20		1.10	10.2	5.4	11	4.3	16	●		
R/L S16.024R12	2.40		1.20	10.2	5.4	11	4.3	16	●		
R/L S16.030R15	3.00		1.50	10.2	5.4	11	4.3	16	●		
R/L S16.U31R15	3.18	0.125"	1.59	10.2	5.4	11	4.3	16	●		
R/L S16.032R16	3.20		1.60	10.2	5.4	11	4.3	16	●		
R/L S16.040R20	4.00		2.00	10.2	5.4	11	4.3	16	●		

616...

Weitere HM Sorten können Sie in der Sortenübersicht im Kapitel "Technische Hinweise" und der Preisliste finden.

More carbide grades you can find in the grades summary in the chapter "technical instructions" and in the price list.

Bestellbeispiel:
für rechte Ausführung und Sorte
RS16.016R08/AL41F

order-example:
righthand version and grade
RS16.016R08/AL41F

MINICUT

Bohrungsbearbeitung

grooving, boring and profiling

Typ Stechdrehen

Ausdrehen und Fasen

type grooving,
boring and chamfering

D min. 7 - 14 mm

D min. 7 - 14 mm

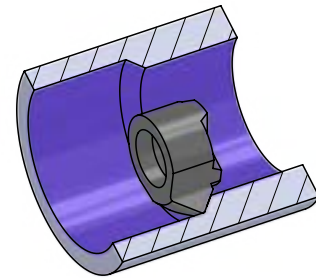
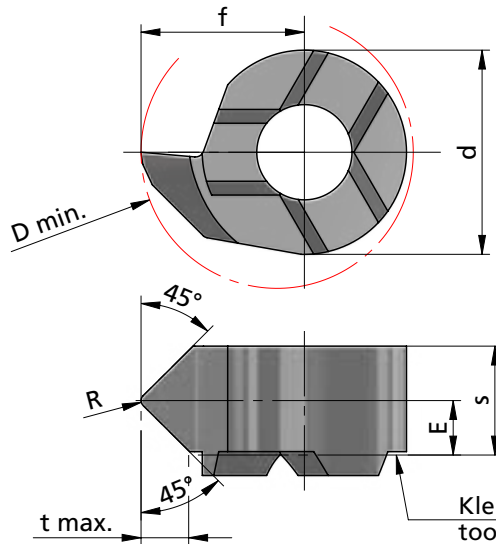

Beispielzeichnung
exemplary application

Rechts (R): wie gezeichnet
Links (L): spiegelbildlich

righthand (R): as shown
lefthand version (L): mirror image

Abmessungen in mm

dimensions in mm

Bestellnummer part number	R	f	s	E	d	t max.	D min.	Klemmhalter Typ toolholder type			
								K10F	AL41F	P18C	
R/L S07.4545.02	0.2	4.2	3.50	2.30	4.8	0.8	7	●			607...
R/L S08.4545.02	0.2	4.8	3.20	1.60	6.0	1.4	8		●		608...
R/L S09.4545.02	0.2	5.5	3.55	1.80	6.2	1.3	9		●		609...
R/L S11.4545.02	0.2	6.7	4.30	2.20	8.0	1.5	11	●	●		611...
R/L S14.4545.02	0.2	9.0	5.35	2.70	9.0	1.5	14	●	●		614...

Weitere HM Sorten können Sie in der Sortenübersicht im Kapitel "Technische Hinweise" und der Preisliste finden.

Bestellbeispiel: für rechte Ausführung und Sorte RS07.4545.02/AL41F

More carbide grades you can find in the grades summary in the chapter "technical instructions" and in the price list.

order-example: righthand version and grade RS07.4545.02/AL41F

MINICUT

Bohrungsbearbeitung

grooving, boring and profiling

Typ Stechdrehen

Vorstechen und Fasen

type grooving,
pregrooving and chamfering

D min. 8 - 16 mm

D min. 8 - 16 mm

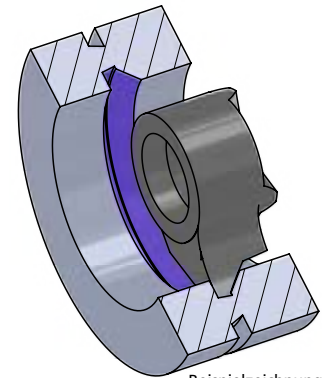
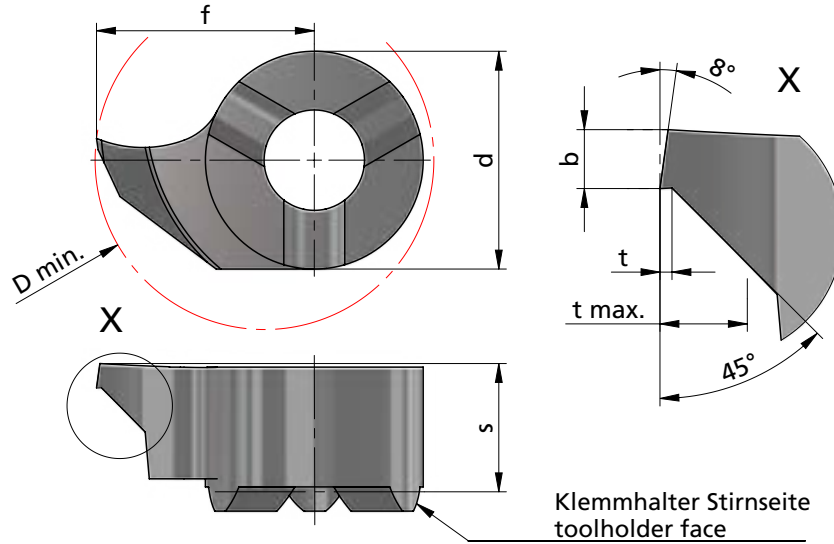

Beispielzeichnung
exemplary application

Rechts (R): wie gezeichnet
Links (L): spiegelbildlich

righthand (R): as shown
lefthand version (L): mirror image

Abmessungen in mm

dimensions in mm

Bestellnummer part number	b	t	f	s	d	t max.	D min.	Klemhalter Typ toolholder type			
								K10F	AL41F	P18C	
R/L S08.0810.45	1	0.2	4.8	3.3	6.0	1.0	8	●	●	●	608...
R/L S09.0810.45	1	0.2	5.5	3.6	6.2	1.5	9	●	●	●	609...
R/L S11.0810.45	1	0.2	6.7	4.2	8.0	1.5	11	●	●	●	611...
R/L S14.0815.45	1	0.2	9.0	5.3	9.0	1.5	14	●	●	●	614...
R/L S16.0815.45	1	0.2	10.2	5.4	11.0	1.5	16	●	●	●	616...

Weitere HM Sorten können Sie in der Sortenübersicht im Kapitel "Technische Hinweise" und der Preisliste finden.

More carbide grades you can find in the grades summary in the chapter "technical instructions" and in the price list.

Bestellbeispiel:
für rechte Ausführung und Sorte
RS14.0815.45/AL41F

order-example:
righthand version and grade
RS14.0815.45/AL41F

MINICUT

Bohrungsbearbeitung

grooving, boring and profiling

Impressionen

impressions



MINICUT

Bohrungsbearbeitung

grooving, boring and profiling

Typ Gewindedrehen

metrisches ISO-Gewinde,
Teilprofil, innen

type threading,
metric ISO-thread,
partial profile, internal

D min. 7 / 8 / 9 mm
Steigung P = 0.5 - 3.5

D min. 7 / 8 / 9 mm
pitch P = 0.5 - 3.5

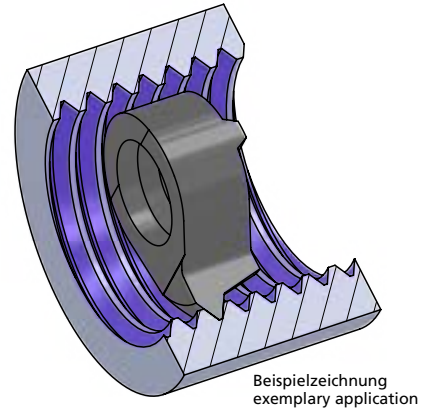
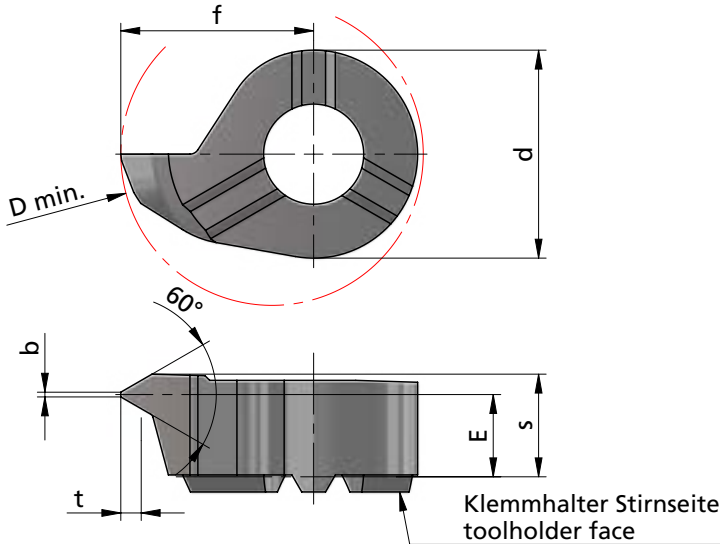

Beispielzeichnung
exemplary application

Rechts (R): wie gezeichnet
Links (L): spiegelbildlich

righthand (R): as shown
lefthand version (L): mirror image

Abmessungen in mm

dimensions in mm

Bestellnummer part number	Steigung P pitch P	t	b	f	s	d	E	D min.	K10F	AL41F	P18C	Klemmhalter Typ toolholder type
R/L S07.0205.01	0.5-0.75	0.44	0.06	4.15	3.3	4.8	2.9	7	●			607...
R/L S07.0510.01	1.0-1.25	0.70	0.12	3.80	3.3	4.8	2.7	7		●		
R/L S07.0815.01	1.5-1.75	0.97	0.18	4.15	3.3	4.8	2.5	7			●	
R/L S08.0205.01	0.5-0.75	0.43	0.06	4.8	3.40	6.0	2.95	8			●	608...
R/L S08.0510.01	1.0-1.25	0.70	0.12	4.8	3.40	6.0	2.60	8	●	●		
R/L S08.0815.01	1.5-1.75	0.98	0.18	4.8	3.40	6.0	2.10	8	●	●		
R/L S09.0205.01	0.5-0.75	0.44	0.06	5.5	3.55	6.2	3.20	9			●	609...
R/L S09.0510.01	1.0-1.25	0.54	0.12	5.5	3.55	6.2	3.00	9			●	
R/L S09.0815.01	1.5-1.75	0.81	0.18	5.5	3.55	6.2	2.80	9			●	
R/L S09.0917.01	1.75-2.0	0.95	0.20	5.5	3.55	6.2	2.60	9			●	
R/L S09.1020.01	2.0-2.5	1.08	0.25	5.5	3.55	6.2	2.50	9			●	
R/L S09.1325.01	2.5-3.0	1.35	0.31	5.5	3.55	6.2	2.10	9			●	
R/L S09.1630.01	3.0-3.5	1.62	0.37	5.5	3.55	6.2	1.90	9			●	

Weitere HM Sorten können Sie in der Sortenübersicht im Kapitel "Technische Hinweise" und der Preisliste finden.

More carbide grades you can find in the grades summary in the chapter "technical instructions" and in the price list.

Bestellbeispiel:
für rechte Ausführung und Sorte
RS07.0205.01/AL41F

order-example:
righthand version and grade
RS07.0205.01/AL41F

MINICUT

Bohrungsbearbeitung

grooving, boring and profiling

Typ Gewindedrehen

metrisches ISO-Gewinde,
Teilprofil, innen

type threading,
metric ISO-thread,
partial profile, internal

D min. 11 / 14 / 16 mm
Steigung P = 0.5 - 3.0

D min. 11 / 14 / 16 mm
pitch P = 0.5 - 3.0

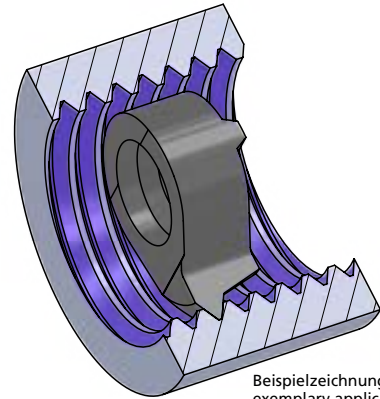
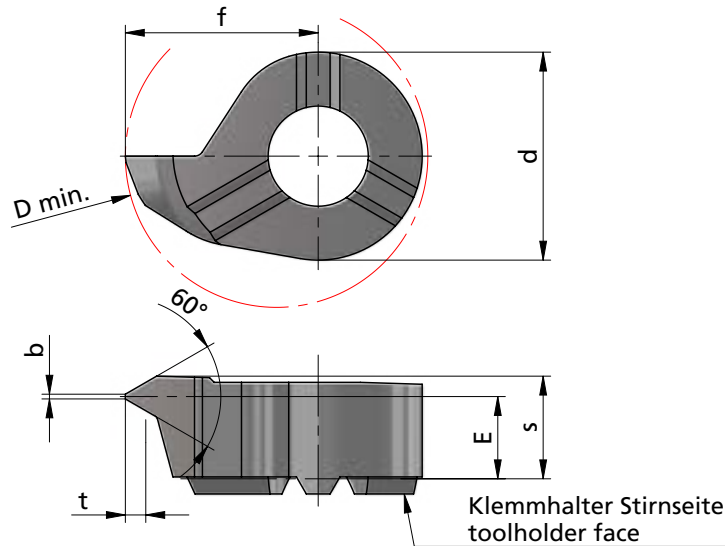

Rechts (R): wie gezeichnet
Links (L): spiegelbildlich

righthand (R): as shown
lefthand version (L): mirror image

Abmessungen in mm

dimensions in mm



Bestellnummer part number	Steigung P pitch P	t	b	f	s	d	E	D min.				Klemmhalter Typ toolholder type
									K10F	AL41F	P18C	
R/L S11.0205.01	0.5-0.75	0.43	0.06	6.7	4.2	8	3.75	11		●		
R/L S11.0510.01	1.0-1.25	0.70	0.12	6.7	4.2	8	3.60	11		●		
R/L S11.0815.01	1.5-1.75	0.98	0.18	6.7	4.2	8	3.20	11		●		611...
R/L S11.1020.01	2.0-2.5	1.41	0.25	6.7	4.2	8	2.90	11		●		
R/L S11.1325.01	2.5-3.0	1.68	0.31	6.7	4.2	8	2.80	11		●		
R/L S14.0510.01	1.0-1.25	0.55	0.12	9.0	5.4	9	4.60	14		●		
R/L S14.0815.01	1.5-1.75	0.81	0.18	9.0	5.4	9	4.30	14		●		614...
R/L S14.1020.01	2.0-2.5	1.08	0.25	9.0	5.4	9	3.90	14		●		
R/L S14.1325.01	2.5-3.0	1.35	0.31	9.0	5.4	9	3.55	14		●		
R/L S16.0510.01	1.0-1.25	0.70	0.12	10.2	5.4	11	4.80	16		●		
R/L S16.0815.01	1.5-1.75	0.98	0.18	10.2	5.4	11	4.60	16		●		616...
R/L S16.1020.01	2.0-2.5	1.41	0.25	10.2	5.4	11	4.35	16		●		
R/L S16.1325.01	2.5-3.0	1.68	0.31	10.2	5.4	11	4.15	16		●		

Weitere HM Sorten können Sie in der Sortenübersicht im Kapitel "Technische Hinweise" und der Preisliste finden.

Bestellbeispiel:
für rechte Ausführung und Sorte
RS14.0510.01/AL41F

More carbide grades you can find in the grades summary in the chapter "technical instructions" and in the price list.

order-example:
righthand version and grade
RS14.0510.01/AL41F

MINICUT

Bohrungsbearbeitung

grooving, boring and profiling

Typ Gewindedrehen

metrisches ISO-Gewinde,
Vollprofil, innen

type threading,
metric ISO-thread,
full profile, internal

D min. 9 / 11 mm
Steigung P = 0.5 - 3.0

D min. 9 / 11 mm
pitch P = 0.5 - 3.0

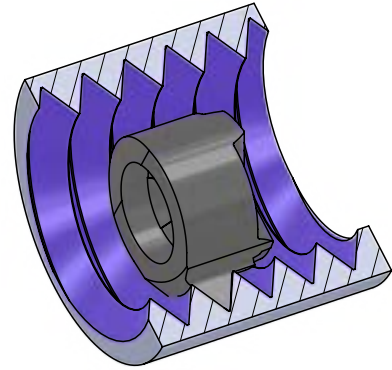
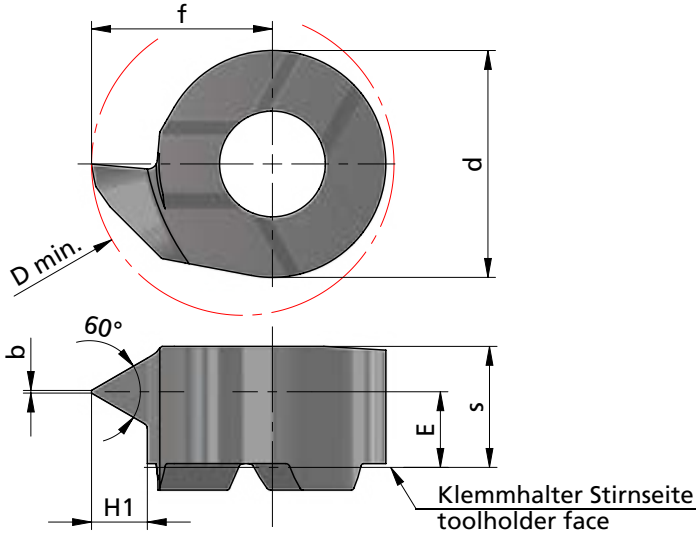

Beispielzeichnung
exemplary application

Rechts (R): wie gezeichnet
Links (L): spiegelbildlich

righthand (R): as shown
lefthand version (L): mirror image

Abmessungen in mm

dimensions in mm

Bestellnummer part number	Steigung P pitch P	H1	b	f	s	d	E	D min.	Klemhalter Typ toolholder type			
									K10F	AL41F	P18C	
R/L S09.0205.02	0.50	0.27	0.06	5.5	3.65	6.2	3.25	9	●	●	●	609...
R/L S09.0510.02	1.00	0.54	0.12	5.5	3.65	6.2	3.00	9	●	●	●	
R/L S09.0815.02	1.50	0.81	0.18	5.5	3.60	6.2	2.80	9	●	●	●	
R/L S09.0917.02	1.75	0.95	0.20	5.5	3.60	6.2	2.70	9	●	●	●	
R/L S09.1020.02	2.00	1.08	0.25	5.5	3.55	6.2	2.60	9	●	●	●	
R/L S09.1325.02	2.50	1.35	0.31	5.5	3.55	6.2	2.50	9	●	●	●	
R/L S09.1630.02	3.00	1.62	0.37	5.5	3.55	6.2	2.20	9	●	●	●	611...
R/L S11.0510.02	1.00	0.54	0.12	6.7	4.30	8.0	3.60	11	●	●	●	
R/L S11.0815.02	1.50	0.81	0.18	6.7	4.30	8.0	3.30	11	●	●	●	
R/L S11.1020.02	2.00	1.08	0.25	6.7	4.30	8.0	2.90	11	●	●	●	
R/L S11.1325.02	2.50	1.35	0.31	6.7	4.30	8.0	2.95	11	●	●	●	
R/L S11.1630.02	3.00	1.62	0.37	6.7	4.30	8.0	2.90	11	●	●	●	

Weitere HM Sorten können Sie in der Sortenübersicht im Kapitel "Technische Hinweise" und der Preisliste finden.

More carbide grades you can find in the grades summary in the chapter "technical instructions" and in the price list.

Bestellbeispiel:
für rechte Ausführung und Sorte
RS11.1630.02/AL41F

order-example:
righthand version and grade
RS11.1630.02/AL41F

MINICUT

Bohrungsbearbeitung

grooving, boring and profiling

Typ Gewindedrehen

metrisches ISO-Gewinde,
Vollprofil, innen

type threading,
metric ISO-thread,
full profile, internal

D min. 14 / 16 mm
Steigung P = 0.5 - 4.0

D min. 14 / 16 mm
pitch P = 0.5 - 4.0

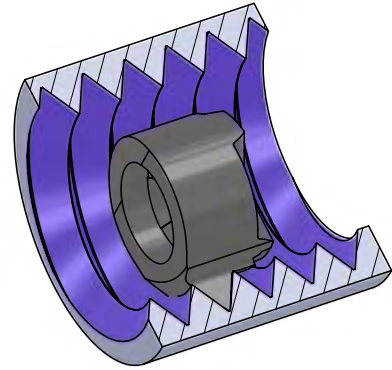
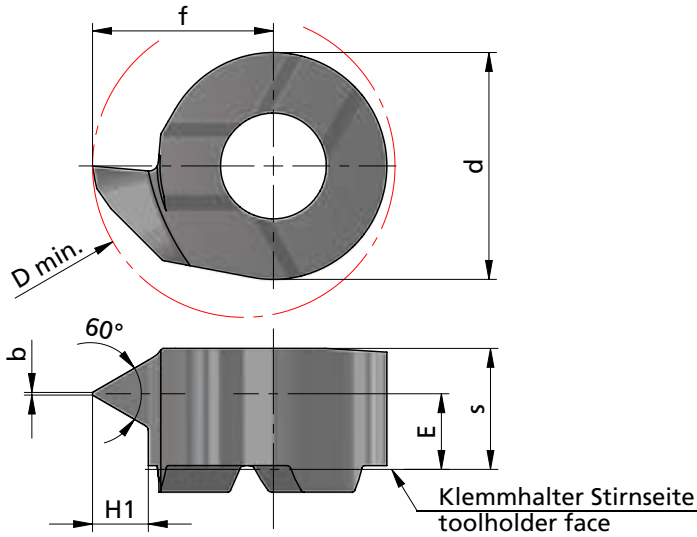

Beispielzeichnung
exemplary application

Rechts (R): wie gezeichnet
Links (L): spiegelbildlich

righthand (R): as shown
lefthand version (L): mirror image

Abmessungen in mm

dimensions in mm

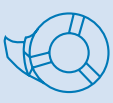

Bestellnummer part number	Steigung P pitch P	H1	b	f	s	d	E	D min.				Klemhalter Typ toolholder type
									K10F	AL41F	P18C	
R/L S14.0205.02	0.5	0.27	0.06	9.0	5.4	9	4.80	14		●		614...
R/L S14.0510.02	1.0	0.54	0.12	9.0	5.4	9	4.70	14		●		
R/L S14.0815.02	1.5	0.81	0.18	9.0	5.4	9	4.30	14		●		
R/L S14.1020.02	2.0	1.08	0.25	9.0	5.4	9	4.20	14		●		
R/L S14.1325.02	2.5	1.35	0.31	9.0	5.4	9	3.65	14		●		
R/L S16.0510.02	1.0	0.54	0.12	10.2	5.5	11	4.80	16		●		616...
R/L S16.0815.02	1.5	0.81	0.18	10.2	5.5	11	4.30	16		●		
R/L S16.1020.02	2.0	1.08	0.25	10.2	5.5	11	4.05	16		●		
R/L S16.1325.02	2.5	1.35	0.31	10.2	5.5	11	4.20	16		●		
R/L S16.1630.02	3.0	1.62	0.37	10.2	5.5	11	4.00	16		●		
R/L S16.1835.02	3.5	1.89	0.43	10.2	5.5	11	3.90	16		●		
R/L S16.2140.02	4.0	2.16	0.50	10.2	5.5	11	3.60	16		●		

Weitere HM Sorten können Sie in der Sortenübersicht im Kapitel "Technische Hinweise" und der Preisliste finden.

Bestellbeispiel:
für rechte Ausführung und Sorte
RS16.0510.02/AL41F

More carbide grades you can find in the grades summary in the chapter "technical instructions" and in the price list.

order-example:
righthand version and grade
RS16.0510.02/AL41F

MINICUT

Bohrungsbearbeitung

grooving, boring and profiling

Typ Gewindedrehen

NPT Vollprofil,
innen

D min. 8 mm

type threading,
NPT full profile, internal

D min. 8 mm

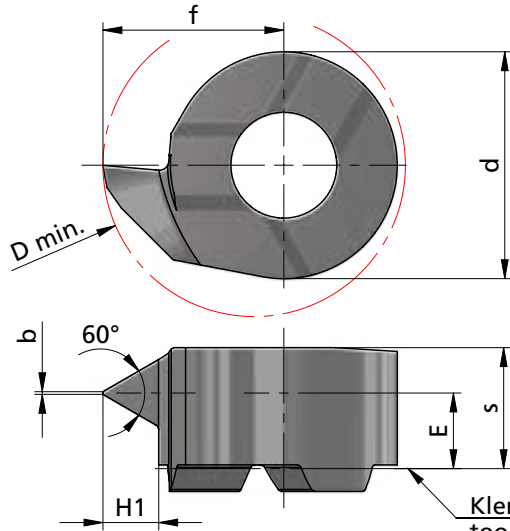

Klemhalter Stirnseite
toolholder face

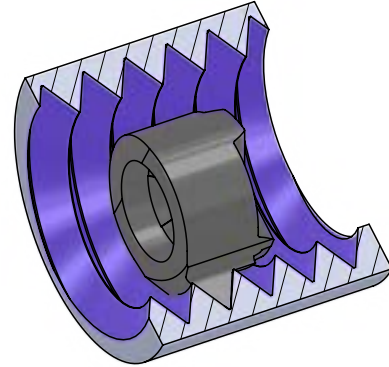

Beispielzeichnung
exemplary application

Rechts (R): wie gezeichnet
Links (L): spiegelbildlich

righthand (R): as shown
lefthand version (L): mirror image

Abmessungen in mm

dimensions in mm

Bestellnummer part number	Steigung P pitch P	H1	Gang / Zoll threads / inch	b	f	s	d	E	D min.	Klemhalter Typ toolholder type		
										K10F	AL41F	P18C
R/L S08.NP14.02	1.814	1.48	14	0.07	4.8	3.2	6	2.0	8	●		
R/L S08.NP18.02	1.411	1.19	18	0.05	4.8	3.5	6	2.6	8	●		608...
R/L S08.NP27.02	0.940	0.80	27	0.04	4.8	3.5	6	2.8	8	●		

Weitere HM Sorten können Sie in der Sortenübersicht im Kapitel "Technische Hinweise" und der Preisliste finden.

More carbide grades you can find in the grades summary in the chapter "technical instructions" and in the price list.

Bestellbeispiel:
für rechte Ausführung und Sorte
RS08.NP14.02/AL41F

order-example:
righthand version and grade
RS08.NP14.02/AL41F

MINICUT

Bohrungsbearbeitung

grooving, boring and profiling

Typ Gewindedrehen

Whitworth-Gewinde,
Vollprofil, innen

type threading,
Whitworth thread,
full profile, internal

D min. 11 / 14 / 16 mm

D min. 11 / 14 / 16 mm

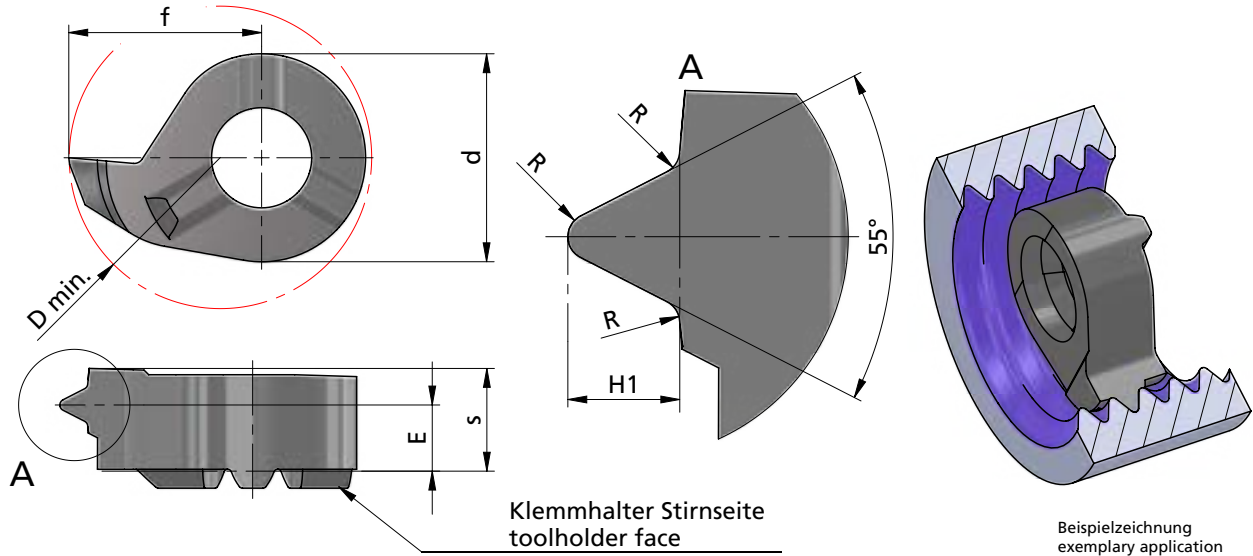

Klemhalter Stirnseite
toolholder face

Beispielzeichnung
exemplary application

Rechts (R): wie gezeichnet
Links (L): spiegelbildlich

righthand (R): as shown
lefthand version (L): mirror image

Abmessungen in mm

dimensions in mm

Bestellnummer part number	Steigung P pitch P		Gang / Zoll threads / inch	R	f	s	d	E	D min.	K10F	AL41F	P18C	Klemhalter Typ toolholder type
	H1	R											
R/L S11.0813.19	1.337	0.85	19	0.18	6.7	4.3	8	2.7	11	●			
R/L S11.1118.14	1.814	1.16	14	0.24	6.7	4.3	8	3.0	11	●			611...
R/L S14.0813.19	1.337	0.85	19	0.18	9.0	5.35	9	3.8	14	●			614...
R/L S14.1118.14	1.814	1.16	14	0.24	9.0	5.40	9	3.6	14	●			
R/L S16.1118.14	1.814	1.16	14	0.24	10.2	5.4	11	3.9	16	●			616...
R/L S16.1423.11	2.309	1.48	11	0.31	10.2	5.4	11	3.5	16	●			

Weitere HM Sorten können Sie in der Sortenübersicht im Kapitel "Technische Hinweise" und der Preisliste finden.

Bestellbeispiel:
für rechte Ausführung und Sorte
RS16.1423.11/AL41F

More carbide grades you can find in the grades summary in the chapter "technical instructions" and in the price list.

order-example:
righthand version and grade
RS16.1423.11/AL41F

MINICUT

Bohrungsbearbeitung

grooving, boring and profiling

Typ Gewindedrehen

Trapezgewinde,
Teilprofil, innen

type threading,
trapezoidal thread,
partial profile, internal

D min. 9 / 10 / 11 mm
Steigung P = 1.5 - 4.0

D min. 9 / 10 / 11 mm
pitch P = 1.5 - 4.0

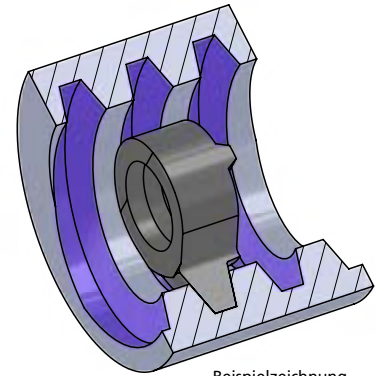
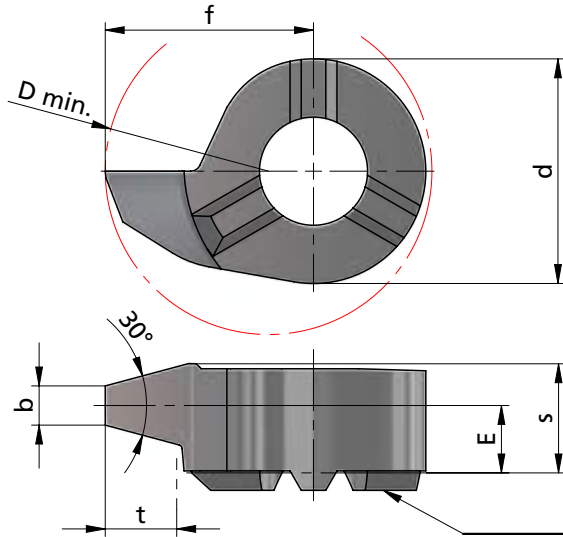

Beispielzeichnung
exemplary application

Rechts (R): wie gezeichnet
Links (L): spiegelbildlich

righthand (R): as shown
lefthand version (L): mirror image

Abmessungen in mm

dimensions in mm

Bestellnummer part number	Steigung P pitch P	t	b	f	s	d	E	D min.	Klemmhalter Typ toolholder type			
									K10F	AL41F	P18C	
R/L S09.1015.01	1.5	0.90	0.47	5.5	3.55	6.2	3.00	9	●	●	●	609...
R/L S09.1220.01	2.0	1.25	0.60	5.5	3.55	6.2	2.85	9	●	●	●	
R/L S09.1730.01	3.0	1.75	0.96	5.5	3.55	6.2	2.25	9	●	●	●	
R/L S09.2240.01	4.0	2.25	1.33	6.5	3.55	6.2	2.25	10	●	●	●	
R/L S11.1015.01	1.5	0.90	0.47	6.7	4.30	8.0	3.7	11	●	●	●	611...
R/L S11.1220.01	2.0	1.25	0.60	6.7	4.30	8.0	3.5	11	●	●	●	
R/L S11.1730.01	3.0	1.75	0.96	6.7	4.30	8.0	3.2	11	●	●	●	
R/L S11.2240.01	4.0	2.25	1.33	6.7	4.00	8.0	2.6	11	●	●	●	

Weitere HM Sorten können Sie in der Sortenübersicht im Kapitel "Technische Hinweise" und der Preisliste finden.

More carbide grades you can find in the grades summary in the chapter "technical instructions" and in the price list.

Bestellbeispiel:
für rechte Ausführung und Sorte
RS09.1015.01/AL41F

order-example:
righthand version and grade
RS09.1015.01/AL41F

MINICUT

Bohrungsbearbeitung

grooving, boring and profiling

Typ Gewindedrehen

Trapezgewinde,
Teilprofil, innen

type threading,
trapezoidal thread,
partial profile, internal

D min. 14 / 16 mm
Steigung P = 2.0 - 6.0

D min. 14 / 16 mm
pitch P = 2.0 - 6.0

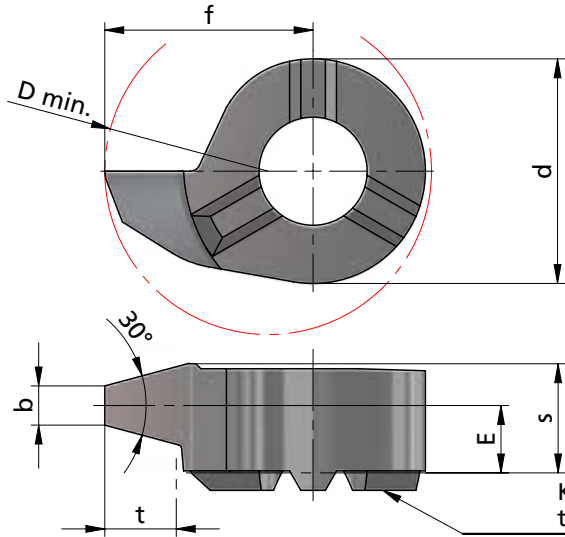

Klemmhalter Stirnseite
toolholder face

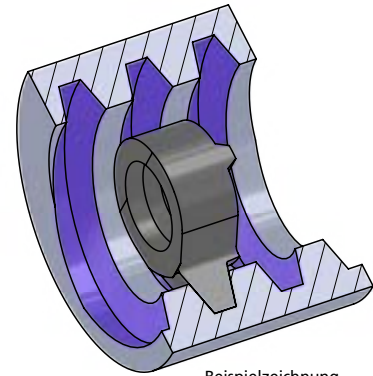

Beispielzeichnung
exemplary application

Rechts (R): wie gezeichnet
Links (L): spiegelbildlich

righthand (R): as shown
lefthand version (L): mirror image

Abmessungen in mm

dimensions in mm

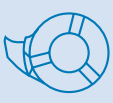

Bestellnummer part number	Steigung P pitch P	t	b	f	s	d	E	D min.	Klemmhalter Typ toolholder type		
									K10F	AL41F	P18C
R/L S14.1220.01	2.0	1.25	0.60	9.0	5.3	9.0	4.3	14	●		
R/L S14.1730.01	3.0	1.75	0.96	9.0	5.3	9.0	4.0	14	●		614...
R/L S14.2240.01	4.0	2.25	1.33	9.0	5.3	9.0	4.0	14	●		
R/L S14.2750.01	5.0	2.75	1.69	9.0	5.3	9.0	3.55	14	●		
R/L S16.1220.01	2.0	1.25	0.60	9.7	5.5	11	4.5	16	●		
R/L S16.1730.01	3.0	1.75	0.96	9.7	5.5	11	4.3	16	●		616...
R/L S16.2240.01	4.0	2.25	1.33	9.7	5.5	11	4.0	16	●		
R/L S16.2750.01	5.0	2.75	1.69	10.2	5.5	11	3.6	16	●		
R/L S16.3560.01	6.0	3.50	1.92	10.2	5.5	11	3.3	16	●		

Weitere HM Sorten können Sie in der Sortenübersicht im Kapitel "Technische Hinweise" und der Preisliste finden.

Bestellbeispiel:
für rechte Ausführung und Sorte
RS14.1220.01AL41F

More carbide grades you can find in the grades summary in the chapter "technical instructions" and in the price list.

order-example:
righthand version and grade
RS14.1220.01AL41F

MINICUT

Bohrungsbearbeitung

grooving, boring and profiling

Impressionen

impressions

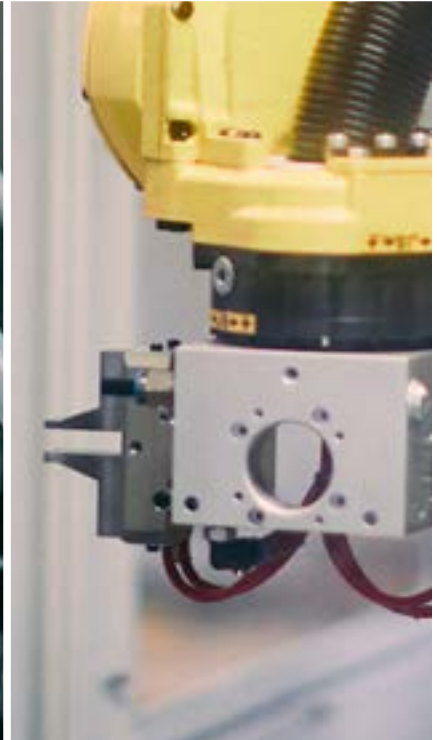

MINICUT

Bohrungsbearbeitung

grooving, boring and profiling

Typ Axialstechen

allgemein

type face grooving

D min. 14 / 18 mm
 Stechtiefe t max. 6 / 10 mm
 Nutbreite bis 3.0 / 4.0 mm

D min. 14 / 18 mm
 depth of groove t max. 6 / 10 mm
 width of groove up to 3.0 / 4.0 mm

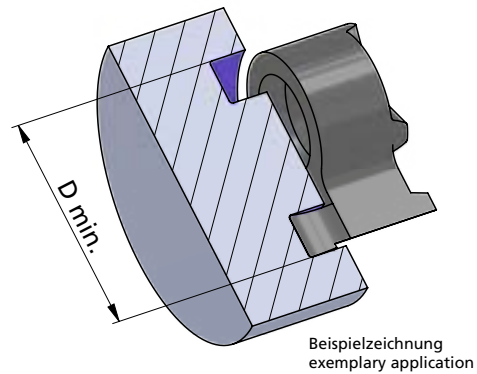
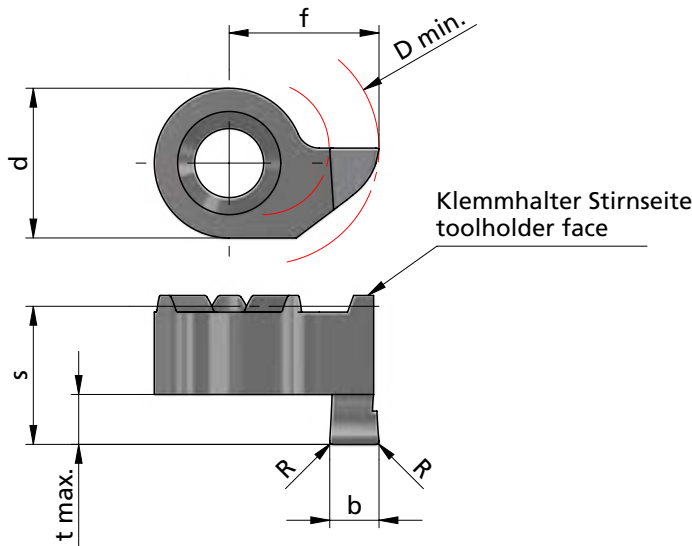

Rechts (R): wie gezeichnet
 Links (L): spiegelbildlich

righthand (R): as shown
 lefthand version (L): mirror image

Abmessungen in mm

dimensions in mm

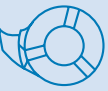

Bestellnummer part number	b		f	R	s	d	t max.	D min.	K10F	AL41F	P18C	Klemmhalter Typ toolholder type
	b+0.03	b (inch)										
R/L S014.1410.00	1.0	9	-	8.3	9	1.5	14		●			
R/L S014.U411.00	1.17	0.046"	9	-	8.3	9	1.5	14		●		
R/L S014.1415.02	1.5	9	0.2	8.3	9	2.5	14		●	●		
R/L S014.1420.02	2.0	9	0.2	8.3	9	3.0	14		●	●		
R/L S014.1425.02	2.5	9	0.2	8.3	9	3.0	14		●	●		614... 614.A...
R/L S014.1430.02	3.0	9	0.2	8.3	9	3.0	14			●		
R/L S014.1420.52	2.0	9	0.2	10.3	9	5.0	14		●	●		
R/L S014.1425.52	2.5	9	0.2	10.3	9	5.0	14		●	●		
R/L S014.1430.52	3.0	9	0.2	10.3	9	5.0	14		●	●		
R/- S014.1430.62	3.0	9	0.2	11.3	9	6.0	14			●		
R/L S018.1830.02	3.0	11	0.2	15.8	11	10	18		●			618...
R/L S018.1840.02	4.0	11.5	0.2	15.8	11	10	18		●			618.A...

Weitere HM Sorten können Sie in der Sortenübersicht im Kapitel "Technische Hinweise" und der Preisliste finden.

Bestellbeispiel:
 für rechte Ausführung und Sorte
 RS014.1410.00/AL41F

More carbide grades you can find in the grades summary in the chapter "technical instructions" and in the price list.

order-example:
 righthand version and grade
 RS014.1410.00/AL41F

MINICUT

Bohrungsbearbeitung

grooving, boring and profiling

Typ Axialstechen

am Zapfen vorbei

type face grooving,
in pivots

D min. 12 / 16 mm
Stechtiefe t max. 6 / 10 mm
Nutbreite bis 3.0 / 4.0 mm

D min. 12 / 16 mm
depth of groove t max. 6 / 10 mm
width of groove up to 3.0 / 4.0 mm

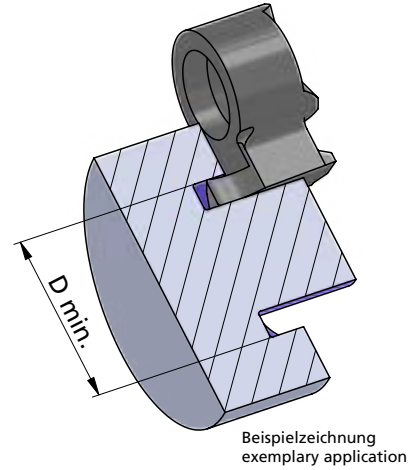
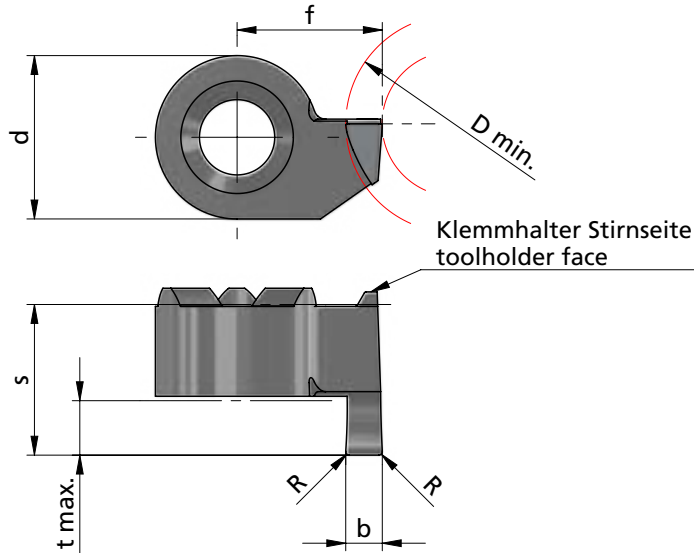

Rechts (R): wie gezeichnet
Links (L): spiegelbildlich

righthand (R): as shown
lefthand version (L): mirror image

Abmessungen in mm

dimensions in mm

Bestellnummer part number	b		f	R	s	d	t max.	D min.	K10F AL41F P18C	Klemmhalter Typ toolholder type
	b+0.03	b (inch)								
R/L S014.1210.00	1.0		7.0	-	8.3	9	1.5	12	● ●	614... 614.A...
R/L S014.1215.02	1.5		7.5	0.2	8.3	9	2.5	12	● ●	
R/L S014.U219.02	1.98	0.078"	8.0	0.2	8.3	9	3.0	12	● ●	
R/L S014.1220.02	2.0		8.0	0.2	8.3	9	3.0	12	● ●	
R/L S014.U223.02	2.39	0.094"	8.4	0.2	8.3	9	3.0	12	● ●	
R/L S014.1225.02	2.5		8.5	0.2	8.3	9	3.0	12	● ●	
R/L S014.1230.02	3.0		9.0	0.2	8.3	9	3.0	12	● ●	
R/L S014.U231.02	3.18	0.125"	9.2	0.2	8.3	9	3.0	12	● ●	
R/L S014.1220.52	2.0		8.0	0.2	10.3	9	5.0	12	● ●	
R/L S014.U223.52	2.39	0.094"	8.4	0.2	10.3	9	5.0	12	● ●	
R/L S014.1225.52	2.5		8.5	0.2	10.3	9	5.0	12	● ●	
R/L S014.1230.52	3.0		9.0	0.2	10.3	9	5.0	12	● ●	
R/- S014.1230.62	3.0		9.0	0.2	11.3	9	6.0	12	● ●	
R/L S018.1630.02	3.0		11	0.2	15.8	11	10	16	● ●	618... 618.A...
R/L S018.1640.02	4.0		12	0.2	15.8	11	10	16	● ●	

Weitere HM Sorten können Sie in der Sortenübersicht im Kapitel "Technische Hinweise" und der Preisliste finden.

More carbide grades you can find in the grades summary in the chapter "technical instructions" and in the price list.

MINICUT

Bohrungsbearbeitung

grooving, boring and profiling

Typ Axialstechen

Vollradius

type face grooving,
full radius

D min. 14 mm
Stechtiefe t max. 5 mm
Nutbreite bis 3.0 mm

D min. 14 mm
depth of groove t max. 5 mm
width of groove up to 3.0 mm

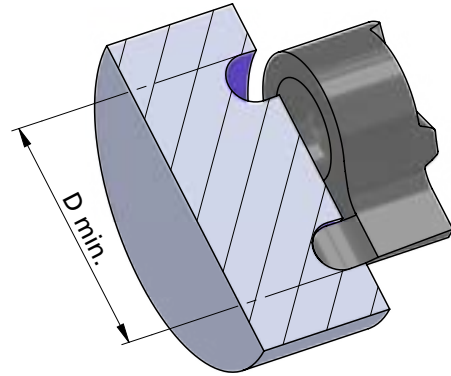
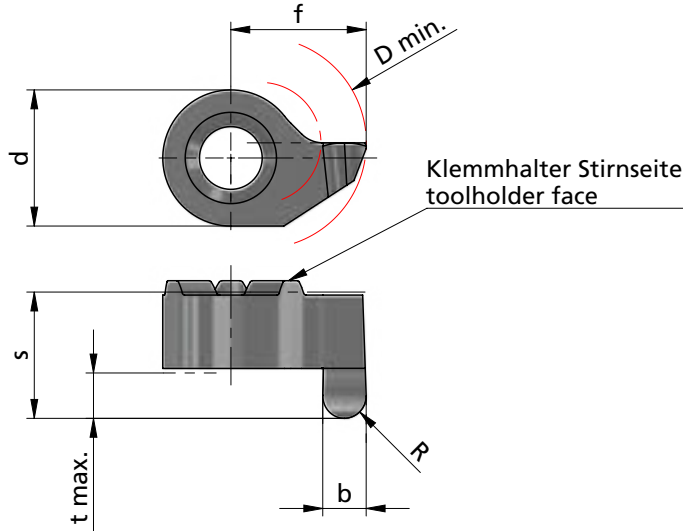

Beispielzeichnung
exemplary application

Rechts (R): wie gezeichnet
Links (L): spiegelbildlich

righthand (R): as shown
lefthand version (L): mirror image

Abmessungen in mm

dimensions in mm



Bestellnummer part number	b		f	R	s	d	t max.	D min.	K10F AL41F P18C	Klemmhalter Typ toolholder type
	b+0.03	b (inch)								
R/L S014.1410.05	1.0		9	0.5	8.3	9	1.5	14	●	614... 614A...
R/L S014.U411.05	1.17	0.046"	9	0.58	8.3	9	1.5	14	●	
R/L S014.1416.08	1.6		9	0.8	8.3	9	2.5	14	●	
R/L S014.1420.10	2.0		9	1.0	8.3	9	3.0	14	●	
R/L S014.1425.12	2.5		9	1.25	8.3	9	3.0	14	●	
R/L S014.1430.15	3.0		9	1.5	8.3	9	3.0	14	●	
R/L S014.1420.50	2.0		9	1.0	10.3	9	5.0	14	●	
R/L S014.1425.50	2.5		9	1.25	10.3	9	5.0	14	●	
R/L S014.1430.50	3.0		9	1.5	10.3	9	5.0	14	●	

Weitere HM Sorten können Sie in der Sortenübersicht im Kapitel "Technische Hinweise" und der Preisliste finden.

More carbide grades you can find in the grades summary in the chapter "technical instructions" and in the price list.

Bestellbeispiel:
für rechte Ausführung und Sorte
RS014.1410.05/AL41F

order-example:
righthand version and grade
RS014.1410.05/AL41F

MINICUT

Bohrungsbearbeitung

grooving, boring and profiling

Typ Axialstechen

am Zapfen vorbei,
Vollradius

type face grooving,
in pivots, full radius

D min. 12 mm
Stechtiefe t max. 5 mm
Nutbreite bis 3.0 mm

D min. 12 mm
depth of groove t max. 5 mm
width of groove up to 3.0 mm

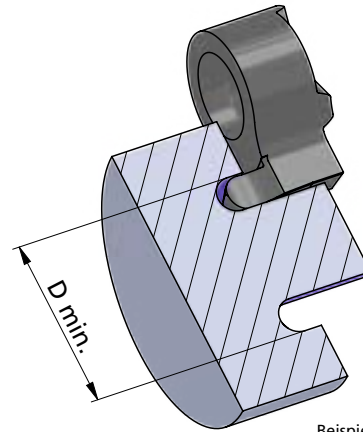
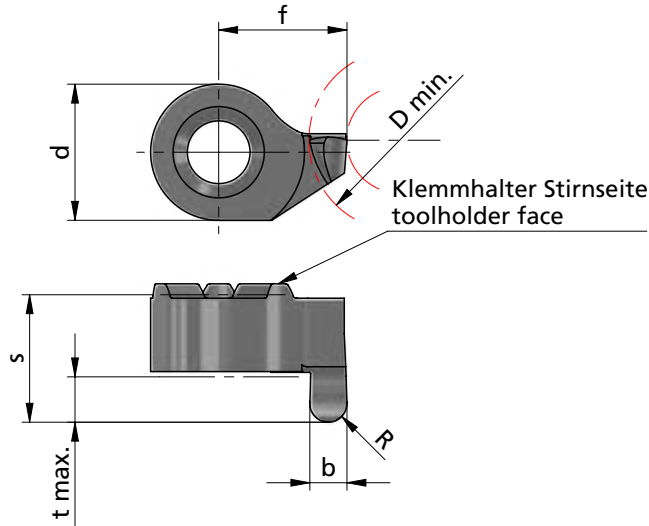

Beispielzeichnung
exemplary application

Rechts (R): wie gezeichnet
Links (L): spiegelbildlich

righthand (R): as shown
lefthand version (L): mirror image

Abmessungen in mm

dimensions in mm

Bestellnummer part number	b+0.03	f	R	s	d	t max.	D min.				Klemhalter Typ toolholder type
								K10F	AL41F	P18C	
R/L S014.1210.05	1.0	7.0	0.5	8.3	9	1.5	12	●			
R/L S014.1216.08	1.6	7.6	0.8	8.3	9	2.5	12	●			614...
R/L S014.1220.10	2.0	8.0	1.0	8.3	9	3.0	12	●			
R/L S014.1225.12	2.5	8.5	1.25	8.3	9	3.0	12	●			
R/L S014.1230.15	3.0	9.0	1.5	8.3	9	3.0	12	●			
R/L S014.1220.50	2.0	8.0	1.0	10.3	9	5.0	12	●			614... 614A...
R/L S014.1225.50	2.5	8.5	1.25	10.3	9	5.0	12	●			
R/L S014.1230.50	3.0	9.0	1.5	10.3	9	5.0	12	●			

Weitere HM Sorten können Sie in der Sortenübersicht im Kapitel "Technische Hinweise" und der Preisliste finden.

More carbide grades you can find in the grades summary in the chapter "technical instructions" and in the price list.

Bestellbeispiel:
für rechte Ausführung und Sorte
RS014.1210.05/AL41F

order-example:
righthand version and grade
RS014.1210.05/AL41F

MINICUT

Bohrungsbearbeitung

grooving, boring and profiling

Sets

D min. 8 mm

D min. 11 mm

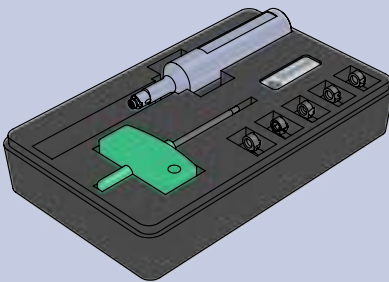
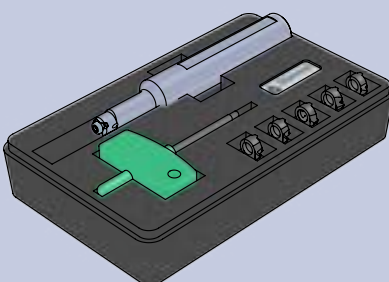

	Bestellnummer part number	Inhalt Content	K10F AL41F P18C CN45F
	<p>SET-MC08-LF/R</p> <ul style="list-style-type: none"> • Ausdrehen und Kopieren (Rechte Ausführung) • Stechdrehen (Rechte Ausführung) • Gewindedrehen (Rechte Ausführung) • boring and profiling (righthand version) • grooving (righthand version) • threading (righthand version) 	<p>Halter / toolholder: 1 x 608.0016.1E.ST</p> <p>Schneideinsatz / insert: 1 x RS008.0090 1 x RS08.008R04 1 x RS08.1846.02 1 x RS08.3046.02 1 x RS08.0815.01</p>	<p>● ● ● ●</p>
	<p>SET-MC11-LF/R</p> <ul style="list-style-type: none"> • Ausdrehen und Kopieren (Rechte Ausführung) • Stechdrehen (Rechte Ausführung) • Gewindedrehen (Rechte Ausführung) • boring and profiling (righthand version) • grooving (righthand version) • threading (righthand version) 	<p>Halter / toolholder: 1 x 611.0016.2E.ST</p> <p>Schneideinsatz / insert: 1 x RS011.0090 1 x RS11.008R04 1 x RS11.1867.02 1 x RS11.3067.02 1 x RS11.1020.01</p>	<p>● ● ● ●</p>
<p>Bestellbeispiel: SET-MC08-LF/R</p>		<p>order-example: SET-MC08-LF/R</p>	

MINICUT

Bohrungsbearbeitung

grooving, boring and profiling

Sets

D min. 14 mm

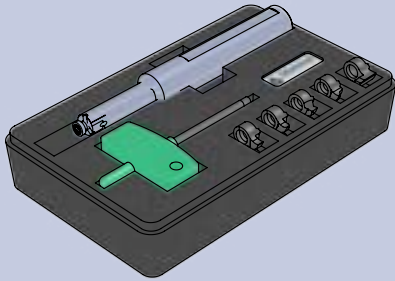

Bestellnummer
part number

SET-MC14-LF/R

- Ausdrehen und Kopieren (Rechte Ausführung)
- Stechdrehen (Rechte Ausführung)
- Vorstechen und Fasen (Rechte Ausführung)
- Axialstechen (Rechte Ausführung)
- boring and profiling (righthand version)
- grooving (righthand version)
- pregrooving and chamfering (righthand version)
- face grooving (righthand version)

Inhalt
Content

Halter / toolholder:

1 x 614.0016.3E.ST

Schneideinsatz / insert:

- 1 x RS014.0300
- 1 x RS14.030R15
- 1 x RS14.1867.02
- 1 x RS14.0815.45
- 1 x RS014.1430.52

K10F
AL41F
P18C
CN45F



MINICUT

Bohrungsbearbeitung

grooving, boring and profiling

Impressionen

impressions



TRICUT

Bohrungsbearbeitung

boring and profiling

Allgemeine Beschreibung

Spangeometrien Tricut

general instruction
cutting geometries Tricut

S - Spangeometrie / S - Cutting geometry

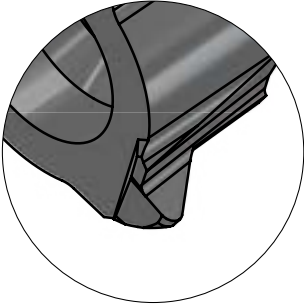

S

- für allgemeines Ausdrehen empfohlen
- recommended for general boring

C - Spangeometrie / C - Cutting geometry

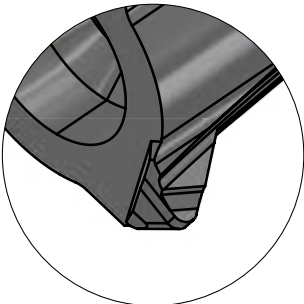

C

- optimierte Spanbildung durch Spantreppe
- optimized chip control caused by special cutting edge

F - Spangeometrie / F - Cutting geometry

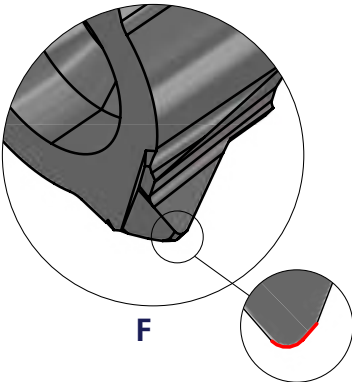

F

- Ausdrehen für perfekte Oberflächen
- boring for perfect surface quality

TRICUT

Bohrungsbearbeitung

boring and profiling

Typ TC08. ... ST

Klemmhalter Stahl
mit Innenkühlung

toolholder steel
with internal cooling

D min. 7.8 mm

D min. 7.8 mm

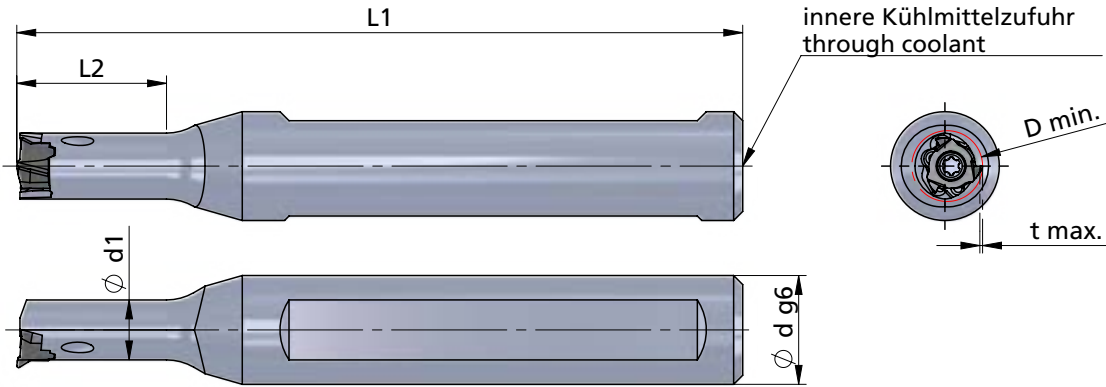

Innenkühlung B*:
Ausschließlich
empfohlen für
Sacklochbohrungen!

internal cooling B*:
Only recommended
for the boring of
blind holes!

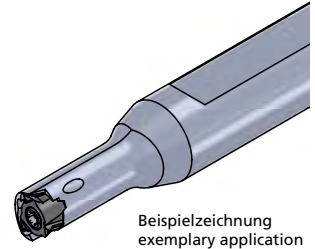

Abmessungen in mm

dimensions in mm



Bestellnummer part number	Ø d g6	Ø d1	L1	L2	Innenkühlung B* intern. cooling B*	Innenkühlung F* intern. cooling F*	Typ: t max. / D min.	Spannschraube screw	Schraubenschlüssel wrench	Anzugs- drehmoment torque	für Schneidplatte use with insert
TC08.B012.1ST	12	6.6	80	6.6	●		RTC08... 0.3/7.8	A.SPS017	T7F-P	0.8 Nm	RTC08..
TC08.B012.2ST	12	6.6	80	16.5	●						
TC08.F012.1ST	12	6.6	80	6.6		●					
TC08.F012.2ST	12	6.6	80	16.5		●					

Bestellbeispiel:
TC08.B012.1ST

order-example:
TC08.B012.1ST

TRICUT

Bohrungsbearbeitung

boring and profiling

Typ TC08. ... HM

Klemmhalter Hartmetall
mit Innenkühlung

D min. 7.8 mm

toolholder carbide
with internal cooling

D min. 7.8 mm

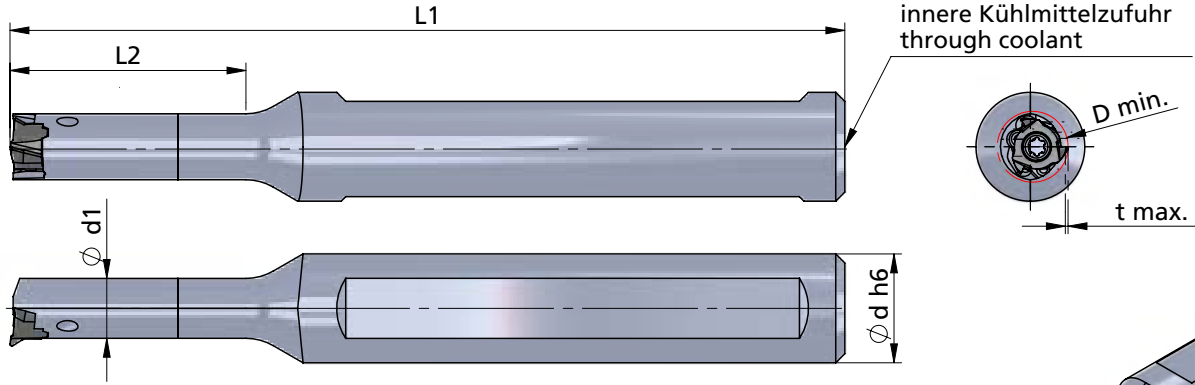

Innenkühlung B*:
Ausschließlich
empfohlen für
Sacklochbohrungen!

internal cooling B*:
Only recommended
for the boring of
blind holes!

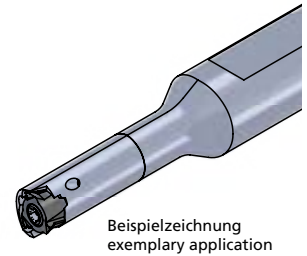

Abmessungen in mm

dimensions in mm

Bestellnummer part number	Ø d h6	Ø d1	L1	L2	Innenkühlung B* intern. cooling B*	Innenkühlung F* intern. cooling F*	Typ: t max. / D min.	Spannschraube screw	Schraubenschlüssel wrench	Anzugs- drehmoment torque	für Schneidplatte use with insert
TC08.B012.1HM	12	6.6	92	26	●		RTC08...; 0.3 / 7.8	A.SPS017	T7F-P	0.8 Nm	RTC08...
TC08.B012.2HM	12	6.6	107	39	●						
TC08.B012.3HM	12	6.6	117	53	●						
TC08.F012.1HM	12	6.6	92	26		●					
TC08.F012.2HM	12	6.6	107	39		●					
TC08.F012.3HM	12	6.6	117	53		●					

Hinweis:
Hartmetall-Klemmhalter mit beschädigter
Schneidplattenaufnahme können durch unseren
Reparaturservice instand gesetzt werden.

note:
carbide-toolholder with damaged seating can be
repaired by Dümmel.

Bestellbeispiel:
TC08.B012.1HM

order-example:
TC08.B012.1HM

TRICUT

Bohrungsbearbeitung

boring and profiling

Typ RTC08.

Ausdrehen und Kopieren,
allgemein

boring and profiling,
general

D min. 7.8 mm

D min. 7.8 mm

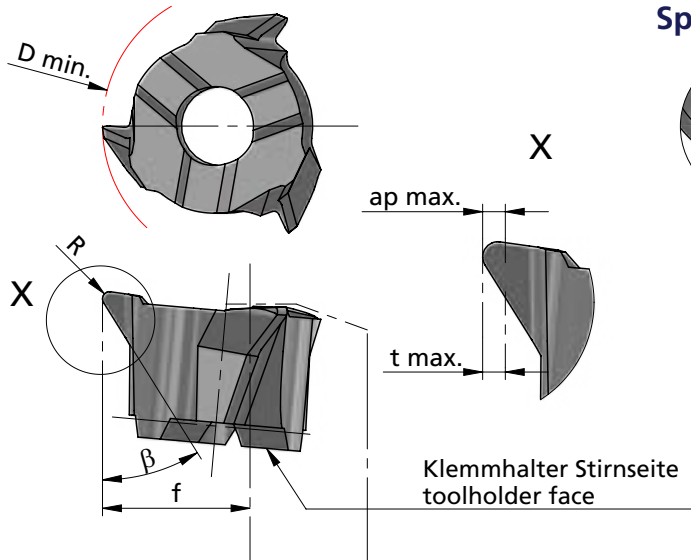

Spangeometrien / Cutting geometries*

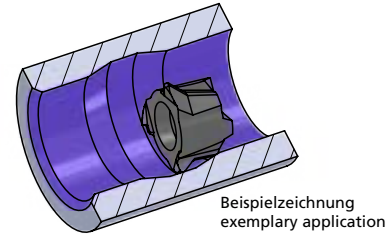
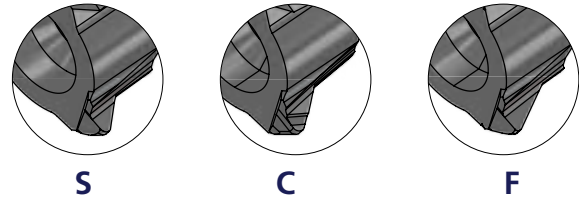

Rechts (R): wie gezeichnet

righthand (R): as shown

Abmessungen in mm

dimensions in mm

Bestellnummer part number	Abmessungen in mm						Spangeometrien* cutting geometries*				Klemmhalter Typ toolholder type
	f	R	β	ap max.**	t max.	D min.	S	C	F	P04C	
R/ TC08.2035F01	4.15	0.1	20°	0.30	0.3	7.8			●	●	
R/ TC08.1835C02	4.15	0.2	18°	0.25	0.3	7.8		●		●	
R/ TC08.1835S02	4.15	0.2	18°	0.30	0.3	7.8	●			●	
R/ TC08.3235C02	4.15	0.2	32°	0.25	0.3	7.8		●		●	TC08....
R/ TC08.3235S02	4.15	0.2	32°	0.30	0.3	7.8	●			●	
R/ TC08.4735C02	4.15	0.2	47°	0.25	0.3	7.8		●		●	
R/ TC08.4735S02	4.15	0.2	47°	0.30	0.3	7.8	●			●	

** ap max. = max. Schnitttiefe
(werkstoffabhängig)

Weitere HM Sorten können Sie in der Sortenübersicht im Kapitel "Technische Hinweise" und der Preisliste finden.
Bestellbeispiel: für rechte Ausführung und Sorte RTC08.2035F01/P04C

* weitere Informationen:
• siehe Allgemeine Beschreibung

* more informations:
• look at the general instruction

** ap max. = max. depth of cut
(depending on material)

More carbide grades you can find in the grades summary in the chapter "technical instructions" and in the price list.
order example: right hand version and grade RTC08.2035F01/P04C

MINICUT

Bohrungsbearbeitung

grooving, boring and profiling

Technische Hinweise

Schnittwerte und Anzahl der Schnitte beim Gewindedrehen

Technical instructions, cutting data and number of passes for threading

Empfohlene Anzahl der Schnitte

Die Anzahl der Schnitte ist nur ein Richtwert für das Gewindedrehen. Um eine möglichst lange Standzeit der Schneide zu erreichen beachten Sie bitte die Erklärungen für die Zustellung. Leerschnitte zum Fertigschneiden sind in dieser Tabelle nicht berücksichtigt.

Recommended number of passes

The number of passes is only a recommendation for threading. To reach a good tool life you have to mention the explanation for the infeed. Finishing passes are not considered in that chart.



		Stahl (Festigkeit N/mm ²) Steel (N/mm ² tensile strength)					rostfreier Stahl stainless steel	Guss cast iron	Alumini- um alumini- um
		400-500	500-700	700-850	850-1150	>1150			
V m/min		160	140	120	90	70	90	100	300
Steigung P Pitch P		Anzahl der Schnitte number of passes							
mm	Gg/" TPI								
0,5	48	5	5	5	5	8	8	5	5
0,8	32	6	6	6	6	8	8	6	6
1	24	7	7	7	7	8	8	7	7
1,25	20-19	8	8	8	8	10	10	8	8
1,5	16	10	10	10	10	12	12	10	10
1,75	14	12	12	12	12	14	14	12	12
2	12-11	13	13	13	13	15	15	13	13
2,5	10	15	15	16	16	18	18	16	15
3 - 3,5	8	16	16	17	17	20	20	17	16
4		18	18	19	19	22	22	19	18
5		20	20	21	21	24	24	21	20
6		22	22	23	23	26	26	23	22

MINICUT

Bohrungsbearbeitung

grooving, boring and profiling

Technische Hinweise

Gewinde schneiden

Technical instructions,
threading

Vorschubrichtung

Mit jedem Schneideinsatz für das Gewindedrehen kann sowohl ein Rechts- wie auch ein Linksgewinde geschnitten werden. Hierbei ist folgende Vorschubrichtung zu beachten:

Feed direction

Every insert can be used for right- and lefthand thread. You only have to consider the following feed direction:

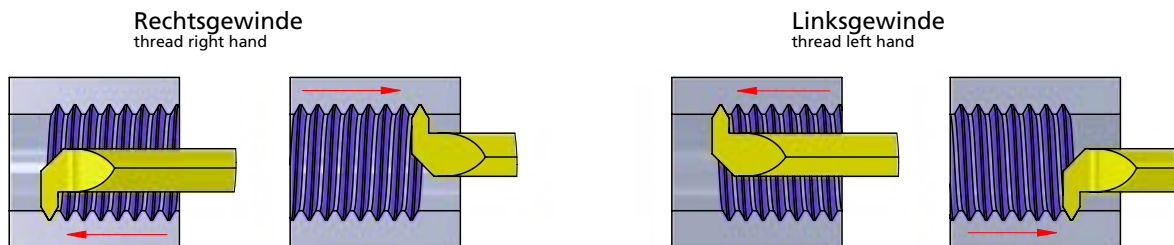

Zustellungsvarianten

Radiale Zustellung	wechselnde Flankenzustellung	einseitige Flankenzustellung
Die meist verwendete Methode um Gewinde herstellen. Beide Schneiden sind gleichzeitig im Eingriff.	Die Schneiden werden wechselnd eingesetzt.	Nur eine Schneidewird für die komplette Gewindeerstellung eingesetzt.
Problematische Spanbildung, dadurch hohe Schnittkräfte und Verschleiß am Werkzeug und Bauteil.	Reduzierung des Schnittdrucks, höhere Standzeit und bessere Spanbildung.	Reduzierung des Schnittdrucks und bessere Spanbildung, aber einseitige Abnutzung des Werkzeugs.

Infeed possibilities

Radial infeed	alternating flank infeed	flank infeed
The most used method for threading. both sides are at the same time in process.	The flanks are alternating used.	Only one cutting edge is used for the complete thread.
Problematic chip forming, high cutting force and weariness at insert and work piece.	Reduced cutting force, higher tool life and chip forming.	Reduced cutting force and better chip forming, but one-sided weariness.

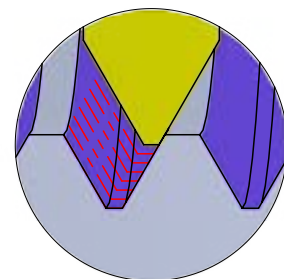
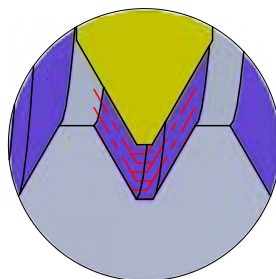
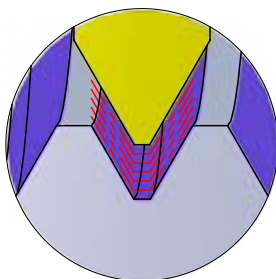

MINICUT

Bohrungsbearbeitung

grooving, boring and profiling

TRICUT

Bohrungsbearbeitung

boring and profiling

Technische Hinweise

Hartmetallsorten und Beschichtungen

Technical instructions,
carbide grades and coatings

K10F

Universell einsetzbares Feinkornhartmetall mit guter Verschleißfestigkeit. Unbeschichtet geeignet für Anwendungen mit niedrigen und mittleren Schnittgeschwindigkeiten, sowie die Bearbeitung von NE-Metallen.

All purpose micrograin carbide with good abrasion resistance. Uncoated for applications with low or medium cutting speeds and machining of non-ferrous materials.

P04C

Optimierte, sehr universell einsetzbare TIALN-Beschichtung mit hoher Temperaturbeständigkeit bei hoher Härte. Sehr gut geeignet auch für NE-Metalle.

Optimized TIALN coating - very universal with a high resistance to high temperature and hardness. Very suitable also for non-ferrous metals.

AL41F

Sehr universell einsetzbare TIALN-Beschichtung mit hoher Temperaturbeständigkeit bei hoher Härte. Sehr gut geeignet auch für NE-Metalle.

TIALN coating - very universal with a high resistance to high temperature and hardness. Very suitable also for non-ferrous metals.

CN45F

Universell einsetzbare PVD-TIN-Beschichtung. Diese Allround-Sorte ist für niedrige und mittlere Schnittgeschwindigkeiten mit Einschränkung bei NE-Metallen.

PVD-TIN coating - all purpose, all around grade is suitable for low and medium cutting speed with restrictions on non-ferrous materials.

P18C

Universell einsetzbare Hochleistungsschicht mit hoher Oxidationsbeständigkeit, Verschleißfestigkeit und Warmhärte.

Very universal high performance coating with high oxidation resistance, wear resistance and hot hardness resistance.

P07C

Beschichtung für die Bearbeitung von Titan, Edelstahl und Molybdän.

Coating to machine titanium, stainless steel and molybdenum.

MINICUT

Bohrungsbearbeitung

grooving, boring and profiling

TRICUT

Bohrungsbearbeitung

boring and profiling

Technische Hinweise

Hartmetallsorten und Beschichtungen

Technical instructions,
carbide grades and coatings

XC2A

Beschichtung mit einer exzellenten Warmhärte, Oxidationsbeständigkeit und thermischen Isolationsfähigkeit. Ideal für Hartzerspanung >60HRC

Coating with excellent hot hardness, high oxidation resistance and thermal insulation capacity. Ideal for hard machining >60 HRC.

P03C

Beschichtung für die Bearbeitung von schwer zerspanbaren Materialien. Sehr gut auch für die Trockenbearbeitung geeignet.

Coating for materials which are difficult to machine. Perfect to use for dry machining.

PD2F

Beschichtung für den universellen Einsatz bei niedrigen und mittleren Schnittgeschwindigkeiten.

Coating for universal use with medium and low speed.

NEME

Beschichtung für die Bearbeitung von Aluminium, Al-Legierungen, NE-Metallen und Kompositwerkstoffen.

Coating for machining aluminium, Al alloys, non-ferrous metals and composite materials.

CBN

Zähe CBN-Sorte für Anwendungen mit niedrigen Schnittgeschwindigkeiten. Geeignet für gehärtete Stähle, unterbrochene Schnitte und Grauguss.

Ductile CBN grade for applications with lower cutting speed. Suitable for hardened steel, interrupted cuts and cast iron.



MINICUT

Bohrungsbearbeitung
grooving, boring and profiling

TRICUT

Bohrungsbearbeitung
boring and profiling

Technische Hinweise

Schnittdatenempfehlung:
metrisch

Schnittgeschwindigkeit: V_c (m/min)
Vorschub: f (mm/U)

Technical instructions,
speed and feed recommendation:
metric

cutting speed: V_c (m/min)
feed: f (mm/rev)



Werkstoffgruppe material group		Zusammensetzung composition		(Zug-)Festigkeit tensile strength	
ISO	Beschreibung / description	Gefüge / structure	Wärmebehandlung / heat treatment	Psi / N/mm ² (Rm) / HB / HRC	
P	Unlegierter Stahl unalloyed steel	ca.Japp. 0,15 % C	geglüht / annealed	61000 Psi / 420 N/mm ² / 125 HB	
		ca.Japp. 0,45 % C	geglüht / annealed	93000 Psi / 640 N/mm ² / 190 HB	
			vergütet / tempered	122000 Psi / 840 N/mm ² / 250 HB	
		ca.Japp. 0,75 % C	geglüht / annealed	132000 Psi / 910 N/mm ² / 270 HB	
	Niedriglegierter Stahl low alloyed steel		vergütet / tempered	146500 Psi / 1010 N/mm ² / 300 HB	
			geglüht / annealed	88500 Psi / 610 N/mm ² / 180 HB	
			vergütet / tempered	135000 Psi / 930 N/mm ² / 275 HB	
			vergütet / tempered	146500 Psi / 1010 N/mm ² / 300 HB	
	Hochlegierter (Werkzeug)-Stahl highly alloyed steel		geglüht / annealed	174000 Psi / 1200 N/mm ² / 375 HB	
			geglüht / annealed	99000 Psi / 680 N/mm ² / 200 HB	
		gehärtet & angelassen / hardened & tempered	160000 Psi / 1100 N/mm ² / 300 HB		
Nichtrostender Stahl stainless steel		gehärtet & angelassen / hardened & tempered	189000 Psi / 1300 N/mm ² / 400 HB		
		ferritisch, martensitisch / ferritic, martensitic	geglüht / annealed	99000 Psi / 610 N/mm ² / 200 HB	
M	Nichtrostender Stahl stainless steel		martensitisch / martensitic	vergütet / tempered	117500 Psi / 810 N/mm ² / 250 HB
			austenitisch / austenitic	abgeschreckt / quenched	88500 Psi / 610 N/mm ² / 200 HB
			austenitisch / austenitic	vergütet / tempered	300 HB
K	Grauguss cast iron		austenitisch, ferritisch / ferritic, martensitic (Duplex)	113000 Psi / 780 N/mm ² / 230 HB	
			perlitisch, ferritisch / pearlitic, ferritic	51000 Psi / 350 N/mm ² / 180 HB	
	Gusseisen mit Kugelgraphit cast iron with nodular graphite		perlitisch (martensitisch) / pearlitic (martensitic)	72500 Psi / 500 N/mm ² / 260 HB	
			ferritisch / ferritic	72500 Psi / 500 N/mm ² / 160 HB	
Temperguss malleable iron		perlitisch / pearlitic	122500 Psi / 845 N/mm ² / 250 HB		
		ferritisch / ferritic	63800 Psi / 440 N/mm ² / 130 HB		
N	Aluminium - Knetlegierungen wrought aluminum alloys		perlitisch / pearlitic	113000 Psi / 780 N/mm ² / 230 HB	
			nicht aushärtbar / uncurable	60 HB	
			aushärtbar / curable	ausgehärtet / cured	49000 Psi / 340 N/mm ² / 100 HB
	Aluminium - Gusslegierungen cast aluminum alloys		≤ 12% Si, nicht aushärtbar / uncurable	ausgehärtet / cured	36250 Psi / 250 N/mm ² / 75 HB
			≤ 12% Si, aushärtbar / curable	ausgehärtet / cured	43500 Psi / 300 N/mm ² / 90 HB
			> 12% Si, nicht aushärtbar / uncurable	ausgehärtet / cured	63800 Psi / 440 N/mm ² / 130 HB
Kupfer und Kupferlegierungen (Bronze / Messing) copper and copper alloys (bronze / brass)		PB > 1 %, Automatenlegierungen / free cutting alloys	ausgehärtet / cured	54500 Psi / 375 N/mm ² / 110 HB	
		CuZn, CuSnZn	ausgehärtet / cured	43500 Psi / 300 N/mm ² / 90 HB	
		CuSn, bleifrei & Elektrolytisch / lead free & electrolytic	ausgehärtet / cured	49000 Psi / 340 N/mm ² / 100 HB	
S	Magnesium & -Legierungen / Mg-alloys		Magnesium und -Legierungen / and -alloys	70 HB	
			Fe-Basis / Fe base	geglüht / annealed	99000 Psi / 680 N/mm ² / 200 HB
H	Warmfeste Legierungen heat-resistant alloys		ausgehärtet / cured	137750 Psi / 950 N/mm ² / 280 HB	
			Ni- oder Co-Basis / Ni- or Co-Base	geglüht / annealed	122000 Psi / 840 N/mm ² / 250 HB
			ausgehärtet / cured	171000 Psi / 1180 N/mm ² / 350 HB	
			gegossen / cast	156600 Psi / 1080 N/mm ² / 320 HB	
	Titanlegierungen titanium alloys		Reintitan / pure titanium	ausgehärtet / cured	58000 Psi / 400 N/mm ²
			Alpha- + Beta-Legierungen / -alloys	ausgehärtet / cured	152250 Psi / 1050 N/mm ²
O	Gehärteter Stahl hardened steel		Beta-Legierungen / -alloys	203000 Psi / 1400 N/mm ² / 410 HB	
			gehärtet & angelassen / hardened & tempered	46-55 HRC	
			gehärtet & angelassen / hardened & tempered	56-60 HRC	
			gehärtet & angelassen / hardened & tempered	61-65 HRC	
			gehärtet & angelassen / hardened & tempered	66-70 HRC	
O	Hartguss / chilled cast iron		gegossen / cast	400 HB	
			gehärtet & angelassen / hardened & tempered	55 HRC	
		Gehärtetes Guss / hardened cast iron		Kunststoffe, duroplastisch / plastics, duroplastic	≤ 21750 Psi / ≤ 150 N/mm ²
				Kunststoffe, thermoplastisch / plastics, thermoplastic	≤ 14500 Psi / ≤ 100 N/mm ²
	aramidfaserverstärkt / aramid fiber reinforced		≤ 145000 Psi / ≤ 1000 N/mm ²		
O	Nichtmetallische Werkstoffe non-metallic materials		glas/kohlefaserverstärkt / glas/carbon fiber reinforced	≤ 145000 Psi / ≤ 1000 N/mm ²	
			Graphit / graphite		

Richtige Schnittgeschwindigkeit ist in Abhängigkeit von Dimension und Anwendungssituation zu wählen.
The correct cutting speed must be selected depending on the dimension and application situation.

20 (10 - 50) bevorzugte Wahl / best choice
20 (10 - 50) bedingt möglich / conditionally possible

20 (10 - 50) empfohlener Startwert recommended starting value (bevorzugter Einsatzbereich) (preferred application area)

Vorschub: feed f: [mm/U] [mm/rev]

Stechdrehen: grooving: 0.01 - 0.03 mm/U
0.01 - 0.03 mm/rev

Ausdrehen / Kopieren: boring / profiling: 0.03 - 0.10 mm/U
0.03 - 0.10 mm/rev

Axialstechen: face grooving: 0.02 - 0.06 mm/U
0.02 - 0.06 mm/rev

MINICUT

Bohrungsbearbeitung

grooving, boring and profiling

TRICUT

Bohrungsbearbeitung

boring and profiling

Technische Hinweise

Schnittdatenempfehlung:
metrisch

Technical instructions,
speed and feed recommendation:
metric

Schnittgeschwindigkeit: V_c (m/min)
Vorschub: f (mm/U)

cutting speed: V_c (m/min)
feed: f (mm/rev)



beispielhafte Werkstoffe exemplary materials				V_c Start (min. - max.)			
DIN	DIN-Code	DIN	DIN-Code	P04C / AL41F [m/min]	CBN [m/min]		
1.0401	C15	1.1141	Ck 15	160 (100 - 260)			
1.1191	C45E	1.0718	9 SMnPb 28	140 (80 - 230)			
1.1191	C45E	1.0535	C 55	140 (80 - 180)			
1.1223	C60R	1.0535	C 55	110 (70 - 180)			
1.1223	C60R	1.0727	45 S 20	100 (60 - 150)			
1.7131	16 MnCr 5	1.6587	17 CrNiMo6	110 (70 - 180)			
1.7131	16 MnCr 5	1.6587	17 CrNiMo6	100 (60 - 150)			
1.7225	42 CrMo 4	1.3505	100Cr6	90 (50 - 140)			
1.7225	42 CrMo 4	1.3505	100Cr6	80 (50 - 130)			
1.4021	X20Cr13	1.4034	X46Cr13	80 (50 - 130)			
1.2343	X 38 CrMoV 5 1	1.4034	X46Cr13	70 (40 - 100)			
1.2343	X 38 CrMoV 5 1	1.4034	X46Cr13	50 (30 - 80)			
1.4016	X 6 Cr 17	1.2316	X36 CrMo 16	100 (60 - 160)			
1.4112	X90CrMoV18	1.2316	X36 CrMo 16	90 (50 - 140)			
1.4301	X 5 CrNi 18 10	1.4571	X2CrNiMo17-12-2	80 (50 - 180)			
1.4841	X15CrNiSi25-21	1.4539	X1NiCrMoCu25-20-5	70 (40 - 140)			
1.4462	X2CrNiMoN22-5-3	1.4501	X2CrNiMoCuWN25-7-4	60 (40 - 110)			
0.6010	GG-10	0.6025	GG-25	90 (50 - 230)			
0.6030	GG-30	0.6045	GG-45	100 (50 - 160)			
0.7040	GGG-40	0.7060	GGG-60	80 (50 - 150)			
0.7070	GGG-70	0.7080	GGG-80	70 (40 - 130)			
0.8035	GTW-35-04	0.8045	GTW-45	120 (70 - 230)			
0.8165	GTS-65-02	0.8170	GTS-70-02	100 (60 - 190)			
3.0255	Al99,5	3.3315	AlMg 1	290 (180 - 540)			
3.1355	AlCuMg2	3.2315	AlMgSi1	280 (170 - 510)			
3.2581	G-AlSi12	3.2163	G-AlSi9Cu3	240 (140 - 440)			
3.2134	G-AlSi5Cu1Mg	3.2373	G-AlSi9Mg	200 (120 - 380)			
-	G-AlSi17Cu4Mg (Silafont-90)	-	G-AlSi18CuNiMg (Silafont-92)	120 (70 - 230)			
2.0380	CuZn39Pb2 (Ms58)	2.0410	CuZn44Pb2	210 (130 - 390)			
2.0331	CuZn15	2.4070	CuZn28Sn1As	180 (110 - 330)			
2.0060	E-Cu57	2.0590	CuZn40Fe	130 (90 - 290)			
3.5612	MgAl6Zn	3.5312	MgAl3Zn	100 (70 - 290)			
1.4864	X12NiCrSi 36-16	1.4865	G-X40NiCrSi38-18	50 (30 - 100)			
1.4980	X6NiCrTiMoVB25-15-2	1.4876	X10NiCrAlTi32-20	30 (20 - 70)	30 (10 - 70)		
2.4631	NiCr20TiAl (Nimonic 80A)	2.4856	NiCr22Mo9Nb (Inconel 625)	50 (30 - 100)	50 (20 - 100)		
2.4668	NiCr19Nb5Mo3 (Inconel 718)	2.4955	NiFe25Cr20NbTi	40 (20 - 80)	30 (10 - 80)		
2.4765	CoCr20W15Ni	1.3401	G-X120Mn12	30 (20 - 60)	30 (10 - 60)		
3.7025	Ti99,8	3.7035	Ti99,7	50 (30 - 100)			
3.7164	TiAl6V4	Ti-6246	Ti-6Al-2Sn-4Zr-6Mo	40 (20 - 60)			
Ti5553	Ti-5Al-5V-5Mo-3Cr	Ti-1023	Ti-10V-2Fe-3Al	30 (20 - 50)	20 (10 - 50)		
				50 (30 - 90)	40 (10 - 90)		
				40 (20 - 80)	30 (10 - 80)		
					30 (10 - 60)		
				40 (20 - 60)	30 (10 - 60)		
				150 (90 - 260)			
				150 (90 - 290)			
				130 (80 - 240)			
				100 (60 - 180)			
				150 (90 - 280)			

Richtige Schnittgeschwindigkeit ist in Abhängigkeit von Dimension und Anwendungssituation zu wählen.

The correct cutting speed must be selected depending on the dimension and application situation.

20 (10 - 50) bevorzugte Wahl / best choice
20 (10 - 50) bedingt möglich / conditionally possible

20 (10 - 50) empfohlener Startwert recommended starting value (bevorzugter Einsatzbereich) (preferred application area)

Vorschub: feed f: [mm/U] [mm/rev]

Stechdrehen: grooving:	0.01 - 0.03 mm/U 0.01 - 0.03 mm/rev
Ausdrehen / Kopieren: boring / profiling:	0.03 - 0.10 mm/U 0.03 - 0.10 mm/rev
Axialstechen: face grooving:	0.02 - 0.06 mm/U 0.02 - 0.06 mm/rev

MINICUT

Bohrungsbearbeitung

grooving, boring and profiling

TRICUT

Bohrungsbearbeitung

boring and profiling

Technische Hinweise

Schnittdatenempfehlung:

Technical instructions,
speed and feed recommendation:
imperial

cutting speed (SFM):
feed:

V_c (feet/min)
 f (inch/rev)



Werkstoffgruppe material group		Zusammensetzung composition		(Zug-)Festigkeit tensile strength	
ISO	Beschreibung / description	Gefüge / structure	Wärmebehandlung / heat treatment	Psi / N/mm ² (Rm) / HB / HRC	
P	Unlegierter Stahl unalloyed steel	ca.lapp. 0,15 % C	geglüht / annealed	61000 Psi / 420 N/mm ² / 125 HB	
		ca.lapp. 0,45 % C	geglüht / annealed	93000 Psi / 640 N/mm ² / 190 HB	
			vergütet / tempered	122000 Psi / 840 N/mm ² / 250 HB	
		ca.lapp. 0,75 % C	geglüht / annealed	132000 Psi / 910 N/mm ² / 270 HB	
	Niedriglegierter Stahl low alloyed steel		vergütet / tempered	146500 Psi / 1010 N/mm ² / 300 HB	
			geglüht / annealed	88500 Psi / 610 N/mm ² / 180 HB	
			vergütet / tempered	135000 Psi / 930 N/mm ² / 275 HB	
			vergütet / tempered	146500 Psi / 1010 N/mm ² / 300 HB	
	Hochlegierter (Werkzeug)-Stahl highly alloyed steel		geglüht / annealed	174000 Psi / 1200 N/mm ² / 375 HB	
			geglüht / annealed	99000 Psi / 680 N/mm ² / 200 HB	
		gehärtet & angelassen / hardened & tempered	160000 Psi / 1100 N/mm ² / 300 HB		
Nichtrostender Stahl stainless steel		gehärtet & angelassen / hardened & tempered	189000 Psi / 1300 N/mm ² / 400 HB		
		ferritisch, martensitisch / ferritic, martensitic	geglüht / annealed	99000 Psi / 680 N/mm ² / 200 HB	
M	Nichtrostender Stahl stainless steel		martensitisch / martensitic	vergütet / tempered	117500 Psi / 810 N/mm ² / 250 HB
			austenitisch / austenitic	abgeschreckt / quenched	88500 Psi / 610 N/mm ² / 200 HB
			austenitisch / austenitic	vergütet / tempered	300 HB
K	Grauguss cast iron		austenitisch, ferritisch / ferritic, martensitic (Duplex)	113000 Psi / 780 N/mm ² / 230 HB	
			perlitisch, ferritisch / pearlitic, ferritic	51000 Psi / 350 N/mm ² / 180 HB	
	Gusseisen mit Kugelgraphit cast iron with nodular graphite		perlitisch (martensitisch) / pearlitic (martensitic)	72500 Psi / 500 N/mm ² / 260 HB	
			ferritisch / ferritic	72500 Psi / 500 N/mm ² / 160 HB	
Temperguss malleable iron		perlitisch / pearlitic	122500 Psi / 845 N/mm ² / 250 HB		
		ferritisch / ferritic	63800 Psi / 440 N/mm ² / 130 HB		
N	Aluminium - Knetlegierungen wrought aluminum alloys		perlitisch / pearlitic	113000 Psi / 780 N/mm ² / 230 HB	
			nicht aushärtbar / uncurable	60 HB	
			aushärtbar / curable	ausgehärtet / cured	49000 Psi / 340 N/mm ² / 100 HB
	Aluminium - Gusslegierungen cast aluminum alloys		≤ 12% Si, nicht aushärtbar / uncurable	ausgehärtet / cured	36250 Psi / 250 N/mm ² / 75 HB
			≤ 12% Si, aushärtbar / curable	ausgehärtet / cured	43500 Psi / 300 N/mm ² / 90 HB
			> 12% Si, nicht aushärtbar / uncurable	ausgehärtet / cured	63800 Psi / 440 N/mm ² / 130 HB
Kupfer und Kupferlegierungen (Bronze / Messing) copper and copper alloys (bronze / brass)		PB > 1 %, Automatenlegierungen / free cutting alloys		54500 Psi / 375 N/mm ² / 110 HB	
		CuZn, CuSnZn		43500 Psi / 300 N/mm ² / 90 HB	
		CuSn, bleifrei & Elektrolytisch / lead free & electrolytic		49000 Psi / 340 N/mm ² / 100 HB	
S	Magnesium & -Legierungen / Mg-alloys		Magnesium und -Legierungen / and -alloys	70 HB	
			Fe-Basis / Fe base	geglüht / annealed	99000 Psi / 680 N/mm ² / 200 HB
H	Warmfeste Legierungen heat-resistant alloys		ausgehärtet / cured	137750 Psi / 950 N/mm ² / 280 HB	
			Ni- oder Co-Basis / Ni- or Co-Base	geglüht / annealed	122000 Psi / 840 N/mm ² / 250 HB
			ausgehärtet / cured	171000 Psi / 1180 N/mm ² / 350 HB	
			gegossen / cast	156600 Psi / 1080 N/mm ² / 320 HB	
			Reintitan / pure titanium		58000 Psi / 400 N/mm ²
		Alpha- + Beta-Legierungen / -alloys	ausgehärtet / cured	152250 Psi / 1050 N/mm ²	
O	Titanlegierungen titanium alloys		Beta-Legierungen / -alloys	203000 Psi / 1400 N/mm ² / 410 HB	
		Gehärteter Stahl hardened steel		gehärtet & angelassen / hardened & tempered	46-55 HRC
				gehärtet & angelassen / hardened & tempered	56-60 HRC
				gehärtet & angelassen / hardened & tempered	61-65 HRC
Hartguss / chilled cast iron		gehärtet & angelassen / hardened & tempered	66-70 HRC		
		gegossen / cast	400 HB		
O	Gehärtetes Guss / hardened cast iron		gehärtet & angelassen / hardened & tempered	55 HRC	
		Nichtmetallische Werkstoffe non-metallic materials		Kunststoffe, duroplastisch / plastics, duroplastic	≤ 21750 Psi / ≤ 150 N/mm ²
				Kunststoffe, thermoplastisch / plastics, thermoplastic	≤ 14500 Psi / ≤ 100 N/mm ²
				aramidfaserverstärkt / aramid fiber reinforced	≤ 145000 Psi / ≤ 1000 N/mm ²
				glas/kohlefaserverstärkt / glas/carbon fiber reinforced	≤ 145000 Psi / ≤ 1000 N/mm ²
	Graphit / graphite				

<p>The correct cutting speed must be selected depending on the dimension and application situation.</p>	<p>20 (10 - 50) best choice</p> <p>20 (10 - 50) conditionally possible</p>	<p>feed f: [inch/rev]</p> <p>grooving: 0.0004 - 0.0012 in/rev</p> <p>boring / profiling: 0.0012 - 0.0039 in/rev</p> <p>face grooving: 0.0008 - 0.0024 in/rev</p>
	<p>20 (10 - 50) recommended starting value (preferred application area)</p>	

MINICUT

Bohrungsbearbeitung

grooving, boring and profiling

TRICUT

Bohrungsbearbeitung

boring and profiling

Technische Hinweise

Schnittdatenempfehlung:

Technical instructions,
speed and feed recommendation:
imperial

cutting speed (SFM):
feed:

V_c (feet/min)
f (inch/rev)

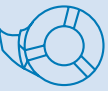

beispielhafte Werkstoffe exemplary materials					V _c Start (min. - max.)			
AISI	DIN-Code	AISI	DIN-Code	AL41F / P04C [SFM]	CBN [SFM]			
1015	C15	1015	Ck 15	520 (330 - 850)				
1045	C45E	12L13	9 SMnPb 28	460 (260 - 750)				
1045	C45E	1055	C 55	460 (260 - 590)				
1060	C60R	1055	C 55	360 (230 - 590)				
1060	C60R	1146	45 S 20	330 (200 - 490)				
5115	16 MnCr 5	4820	17 CrNiMo6	360 (230 - 590)				
5115	16 MnCr 5	4820	17 CrNiMo6	330 (200 - 490)				
4140	42 CrMo 4	E52100	100Cr6	300 (160 - 460)				
4140	42 CrMo 4	E52100	100Cr6	260 (160 - 430)				
420	X20Cr13	420	X46Cr13	260 (160 - 430)				
H11	X 38 CrMoV 5 1	420	X46Cr13	230 (130 - 330)				
H11	X 38 CrMoV 5 1	420	X46Cr13	160 (100 - 260)				
430/1	X 6 Cr 17	422	X36 CrMo 16	330 (200 - 520)				
440B	X90CrMoV18	422	X36 CrMo 16	300 (160 - 460)				
304	X 5 CrNi 18 10	316Ti	X2CrNiMo17-12-2	260 (160 - 590)				
314	X15CrNiSi25-21	904L	X1NiCrMoCu25-20-5	230 (130 - 460)				
318	X2CrNiMoN22-5-3	A790	X2CrNiMoCuWN25-7-4	200 (130 - 360)				
No 20B	GG-10	No 35B	GG-25	300 (160 - 750)				
No 45B	GG-30	-	GG-45	330 (160 - 520)				
60-40-18	GGG-40	80-55-06	GGG-60	260 (160 - 490)				
100-70-03	GGG-70	120-90-02	GGG-80	230 (130 - 430)				
-	GTW-35-04	-	GTW-45	390 (230 - 750)				
A220-70003	GTS-65-02	A220-80002	GTS-70-02	330 (200 - 620)				
A91060	Al99,5	5005A	AlMg 1	950 (590 - 1770)				
2024	AlCuMg2	6082	AlMgSi1	920 (560 - 1670)				
A04130	G-AlSi12	-	G-AlSi9Cu3	790 (460 - 1440)				
355.1	G-AlSi5Cu1Mg	-	G-AlSi9Mg	660 (390 - 1250)				
-	G-AlSi17Cu4Mg (Silafont-90)	-	G-AlSi18CuNiMg (Silafont-92)	390 (230 - 750)				
C37700	CuZn39Pb2 (Ms58)	C38500	CuZn44Pb2	690 (430 - 1280)				
C34000	CuZn15	-	CuZn28Sn1As	590 (360 - 1080)				
C11000	E-Cu57	-	CuZn40Fe	430 (300 - 950)				
AZ61A	MgAl6Zn	AZ31B	MgAl3Zn	330 (230 - 950)				
330	X12NiCrSi 36-16	-	G-X40NiCrSi38-18	160 (100 - 330)				
A286	X6NiCrTiMoVB25-15-2	B163	X10NiCrAlTi32-20	100 (70 - 230)	100 (30 - 230)			
-	NiCr20TiAl (Nimonic 80A)	SB443	NiCr22Mo9Nb (Inconel 625)	160 (100 - 330)	160 (70 - 330)			
-	NiCr19Nb5Mo3 (Inconel 718)	-	NiFe25Cr20NbTi	130 (70 - 260)	100 (30 - 260)			
-	CoCr20W15Ni	A 128 75	G-X120Mn12	100 (70 - 200)	100 (30 - 200)			
R 50250	Ti99,8	R 50400	Ti99,7	160 (100 - 330)				
R 56400	TiAl6V4	R 56260	Ti-6Al-2Sn-4Zr-6Mo	130 (70 - 200)				
-	Ti-5Al-5V-5Mo-3Cr	R 56410	Ti-10V-2Fe-3Al	100 (70 - 160)	70 (30 - 160)			
				160 (100 - 300)	130 (30 - 300)			
				130 (70 - 260)	100 (30 - 260)			
					100 (30 - 200)			
				130 (70 - 200)	100 (30 - 200)			
				490 (300 - 850)				
				490 (300 - 950)				
				430 (260 - 790)				
				330 (200 - 590)				
				490 (300 - 920)				

The correct cutting speed must be selected depending on the dimension and application situation.

20 (10 - 50) best choice
20 (10 - 50) conditionally possible

20 (10 - 50) recommended starting value (preferred application area)

feed f: [inch/rev]

grooving: 0.0004 - 0.0012 in/rev

boring / profiling: 0.0012 - 0.0039 in/rev

face grooving: 0.0008 - 0.0024 in/rev



duemmel.de



M F T O O L S

Typ DT: D min. $\geq \varnothing 2.00$ mm

Typ DT MAX: D min. $\geq \varnothing 7.85$ mm

MF TOOLS

Multifunktionswerkzeug
zum Bohren und Ausdrehen

Multifunctional tool
drilling and boring

Übersicht

summary

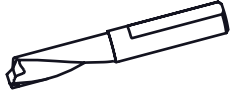

Allgemeine Beschreibung
Typ DT

general instructions
type DT

... 4

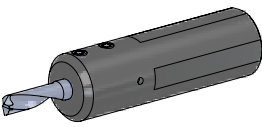

**Klemmhalter
Typ DT**

**toolholder
type DT**

**Maße
dimensions
[mm]**

**Seite
page**

Typ 640P.DT / 650P.DT /

Klemmhalter,
durch tiefere Werkzeugspannung
optimiert für Schneideinsatz Typ DT

toolholder,
by deeper insert clamping
optimized for insert type DT

∅ 12 - 25.4
D min. 2.9 - 4.7

... 6

Typ 660P.DT / 670P.DT /

Klemmhalter,
durch tiefere Werkzeugspannung
optimiert für Schneideinsatz Typ DT

toolholder,
by deeper insert clamping
optimized for insert type DT

∅ 12 - 25.4
D min. 5.7 - 6.7

... 7

Typ 680P.DT

Klemmhalter,
durch tiefere Werkzeugspannung
optimiert für Schneideinsatz Typ DT

toolholder,
by deeper insert clamping
optimized for insert type DT

∅ 12 - 25.4
D min. 7.7

... 8

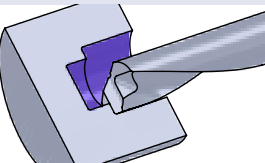

**Schneideinsätze Typ DT
Bohren und
Ausdrehen**

**inserts type DT
drilling and
boring**

**Maße
dimensions
[mm]**

**Seite
page**

Typ DT

Bohren und Ausdrehen

drilling and boring

D min. 2.0 - 7.7

... 9

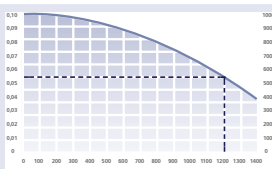

Technische Hinweise

Technical Instructions

**Seite
page**

Hartmetallsorten und Beschichtungen
für Typ DT

carbide grades and coatings
of type DT

... 18

Allgemeine Informationen über
Schnitttiefe und Vorschub
für Typ DT

General instructions about
cutting depth and feed
of type DT

... 21

Schnittdatenempfehlung
für Typ DT

speed and feed recommendation
of type DT

... 24

MF TOOLS

Multifunktionswerkzeug
zum Bohren und Ausdrehen

Multifunctional tool
drilling and boring

Übersicht

summary



Allgemeine Beschreibung
Typ DT MAX

general instructions
type DT MAX

... 4

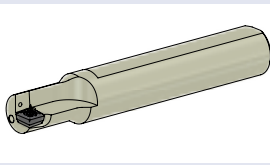

**Klemmhalter
Typ DT MAX**

**toolholder
type DT MAX**

**Maße
dimensions
[mm]**

**Seite
page**

Typ H.MDT

Klemmhalter,
Stechtiefe 1,5 x D

toolholder,
cutting depth 1,5 x D

D min. 7.85 -
D max. 33

... 12

Typ H.MDT

Klemmhalter,
Stechtiefe 2.25 x D

toolholder,
cutting depth 2.25 x D

D min. 7.85 -
D max. 33

... 14

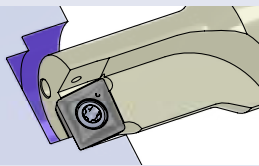

**Wendeschneidplatten Typ DT MAX
Bohren und
Ausdrehen**

**indexable inserts type DT MAX
drilling and
boring**

**Maße
dimensions
[mm]**

**Seite
page**

**Typ MDR.E / MDL.E /
MDN.E**

Bohren und Ausdrehen

drilling and boring

D min. 7.85 -
D max. 33

... 16

Typ MDN.F

Bohren und Ausdrehen
für Aluminium

drilling and boring
for aluminium

D min. 7.85 -
D max. 33

... 17

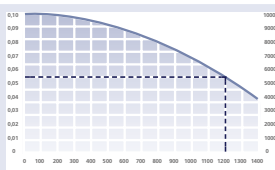

Technische Hinweise

Technical Instructions

**Seite
page**

Hartmetallsorten und Beschichtungen
Typ DT MAX

carbide grades and coatings
type DT MAX

... 20

Allgemeine Informationen über
Schnitttiefe und Vorschub
für Typ DT MAX

General instructions about cutting
depth and feed
for type DT MAX

... 22

Schnittdatenempfehlung
Typ DT MAX

speed and feed recommendation
type DT MAX

... 28

MF TOOLS

Multifunktionswerkzeug
zum Bohren und Ausdrehen

Multifunctional tool
drilling and boring

Allgemeine Beschreibung

general instruction

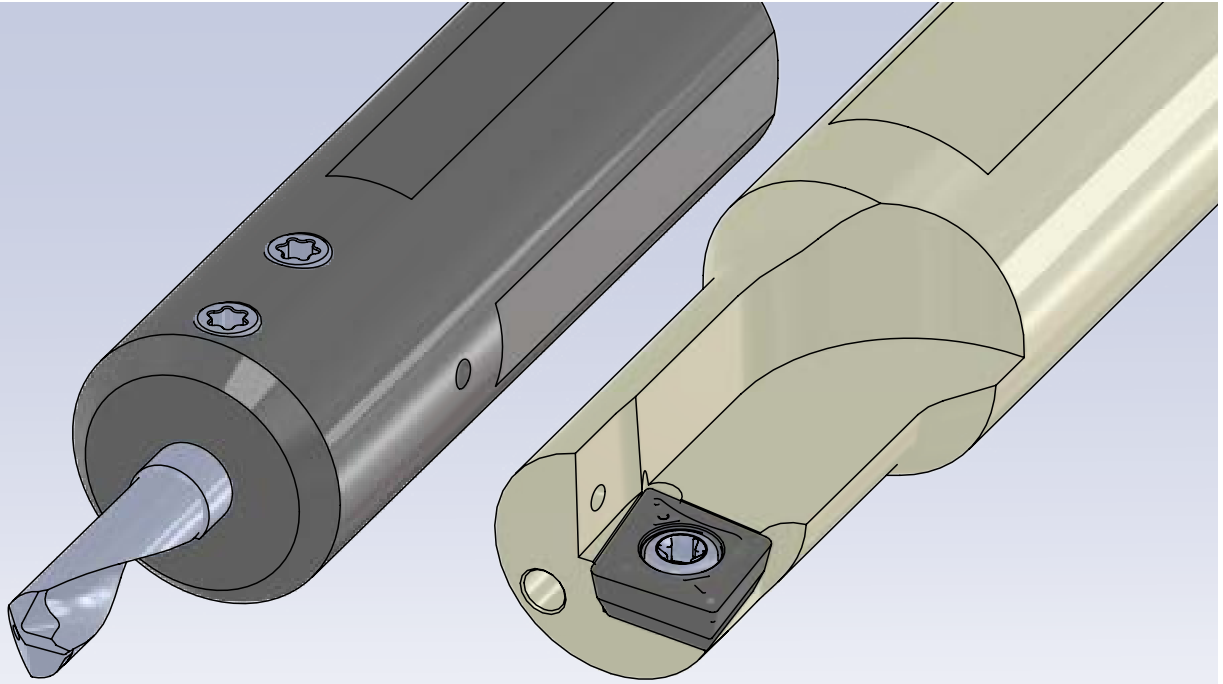

**Typ DT und Typ DT MAX :
Einfacher, komfortabler und produktiver arbeiten, dank MF Tools.**

Type DT and DT MAX :
Simple, comfortable and productive work, thanks to MF Tools.

Vorteile	advantages
<ul style="list-style-type: none"> • geringere Bearbeitungszeit • geringerer Bedarf an Werkzeugplätzen • erzeugt ebenen Bohrungsgrund • weniger Programmieraufwand • niedrigere Rüstkosten / reduzierte Voreinstellzeit • Zeitgewinn durch weniger Werkzeugwechsel 	<ul style="list-style-type: none"> • reduced machining time • reduced need for tool positions • generates flat bottom of hole • less programming • lower set-up costs / reduced setting time • time savings due to fewer tool changes

MF TOOLS

Multifunktionswerkzeug
zum Bohren und Ausdrehen

Multifunctional tool
drilling and boring





Allgemeine Beschreibung

general instruction

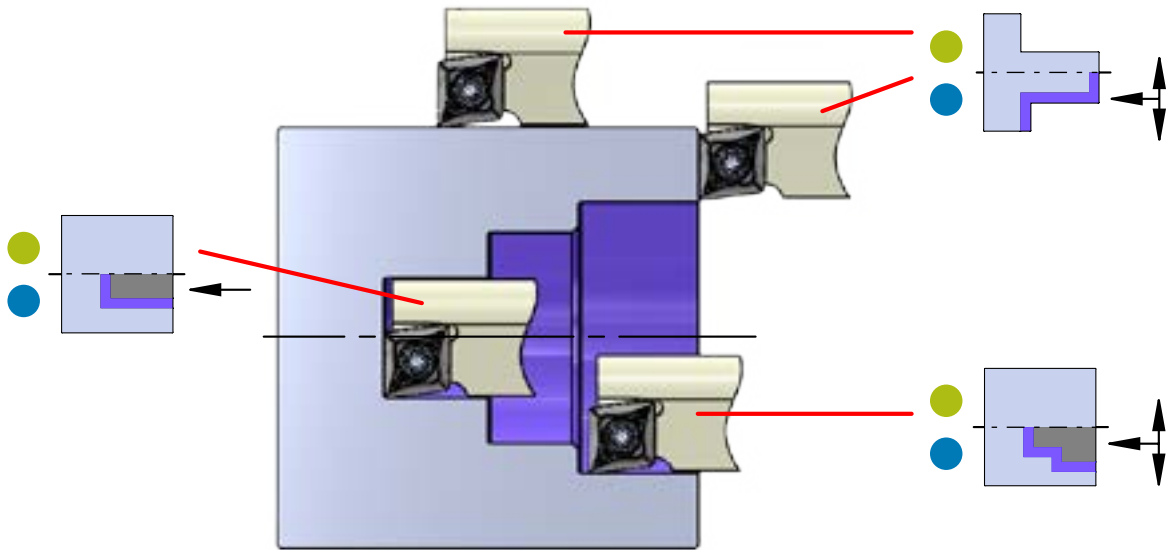
Anwendungsmöglichkeiten :

application possibilities :

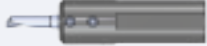

Werkzeuge / tools			Anwendungen / applications			Seite / page
Dimension	Bohren Ø mm	max. Bohrtiefe mm				
dimension	drilling Ø mm	max. depth of bore mm				
 Typ DT	2.25 x D	3 - 8	10 - 20	✓	✓	03-6
	4 x D	2 - 8	8 - 35	✓	✓	
 Typ DT MAX	1.5 x D	8 - 32	12 - 48	✓	✓	03-12
	2.25 x D	8 - 32	18 - 72	✓	✓	

TYP DT

Multifunktionswerkzeug
zum Bohren und Ausdrehen

Multifunctional tool
drilling and boring

Typ 640P.DT / 650P.DT

Klemmhalter,
durch tiefere Werkzeugspannung
optimiert für Schneideinsatz Typ DT

toolholder,
by deeper insert clamping
optimized for insert type DT

Ø 12 - 25.4 mm
für Schneideinsatz mit
D min. 2.9 - 4.7 mm

Ø 12 - 25.4 mm
for insert with
D min. 2.9 - 4.7 mm

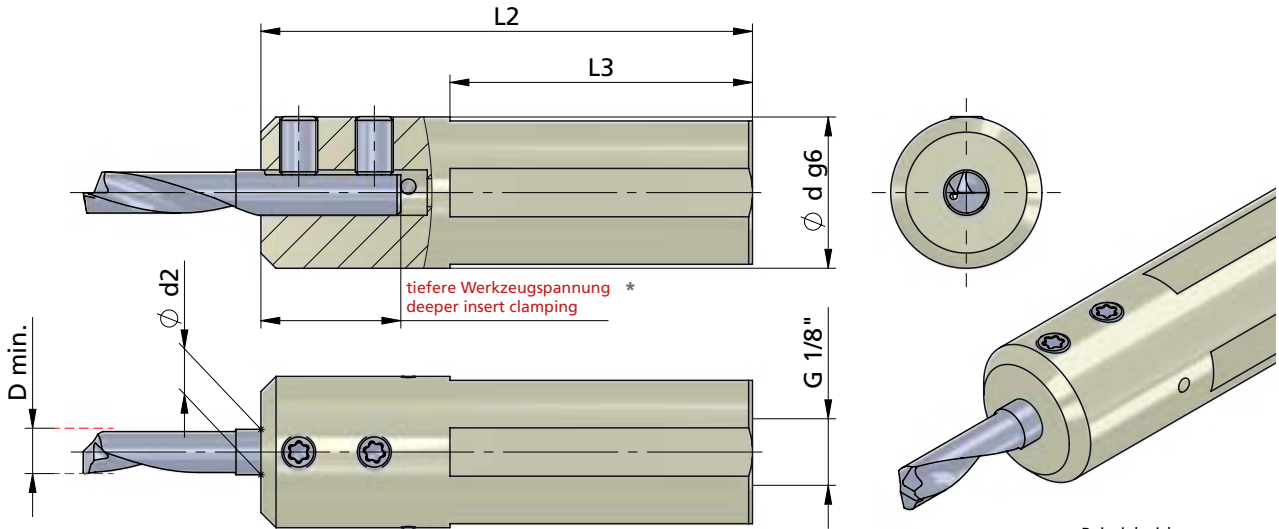

Beispielzeichnung
exemplary application

Klemmhalter für rechte und linke
Schneideinsätze einsetzbar

toolholder for right and left
inserts usable

Abmessungen in mm

dimensions in mm



Bestellnummer part number	Ø d g6	Ø d (inch)	L2	L3	Spannschraube screw	Schraubenschlüssel wrench	Anzugs- drehmoment torque	Ø d2 ≤ Ø d h6	Schneideinsatz Typ insert type
640P.DT12	12		65	40	A.GST010	T10F	1.2 Nm	4	
640P.DT16	16		65	40	A.GST011	T10F	1.2 Nm	4	
640P.DT1905	19.05	3/4"	65	40	A.GST011	T10F	1.2 Nm	4	
640P.DT20	20		65	40	A.GST012	T10F	1.2 Nm	4	R/L DT.4 ...
640P.DT22	22		65	40	A.GST012	T10F	1.2 Nm	4	
640P.DT25	25		65	40	A.GST013	T10F	1.2 Nm	4	
640P.DT254	25.4	1"	65	40	A.GST013	T10F	1.2 Nm	4	
650P.DT12	12		65	40	A.GST010	T10F	1.2 Nm	5	
650P.DT16	16		65	40	A.GST011	T10F	1.2 Nm	5	
650P.DT1905	19.05	3/4"	65	40	A.GST011	T10F	1.2 Nm	5	
650P.DT20	20		65	40	A.GST012	T10F	1.2 Nm	5	R/L DT.5 ...
650P.DT22	22		65	40	A.GST012	T10F	1.2 Nm	5	
650P.DT25	25		65	40	A.GST013	T10F	1.2 Nm	5	
650P.DT254	25.4	1"	65	40	A.GST013	T10F	1.2 Nm	5	

Achtung: nur für Schneiden Typ DT geeignet

attention: only usable for inserts type DT

* Achtung: nicht für Ultramini geeignet
attention: not suitable for Ultramini

TYP DT

Multifunktionswerkzeug
zum Bohren und Ausdrehen

Multifunctional tool
drilling and boring

Typ 660P.DT / 670P.DT

Klemmhalter,
durch tiefere Werkzeugspannung
optimiert für Schneideinsatz Typ DT

toolholder,
by deeper insert clamping
optimized for insert type DT

Ø 12 - 25.4 mm
für Schneideinsatz mit
D min. 5.7 - 6.7 mm

Ø 12 - 25.4 mm
for insert with
D min. 5.7 - 6.7 mm

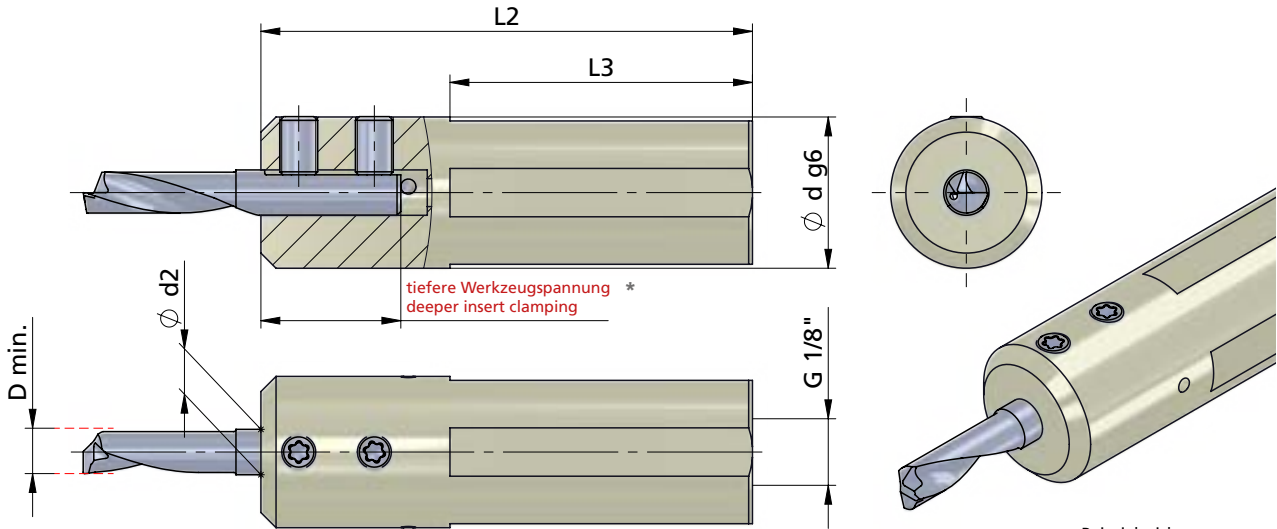

Beispielzeichnung
exemplary application

Klemmhalter für rechte und linke
Schneideinsätze einsetzbar

toolholder for right and left
inserts usable

Abmessungen in mm

dimensions in mm



Bestellnummer part number	Ø d g6	Ø d (inch)	L2	L3	Spannschraube screw	Schraubenschlüssel wrench	Anzugs- drehmoment torque	Ø d2 ≤ Ø d h6	Schneideinsatz Typ insert type
660P.DT12	12		65	40	A.GST011	T10F	1.2 Nm	6	
660P.DT16	16		65	40	A.GST011	T10F	1.2 Nm	6	
660P.DT1905	19.05	3/4"	65	40	A.GST011	T10F	1.2 Nm	6	
660P.DT20	20		65	40	A.GST012	T10F	1.2 Nm	6	R/L DT.6 ...
660P.DT22	22		65	40	A.GST012	T10F	1.2 Nm	6	
660P.DT25	25		65	40	A.GST013	T10F	1.2 Nm	6	
660P.DT254	25.4	1"	65	40	A.GST013	T10F	1.2 Nm	6	
670P.DT12	12		65	40	A.GST011	T10F	1.2 Nm	7	
670P.DT16	16		65	40	A.GST011	T10F	1.2 Nm	7	
670P.DT1905	19.05	3/4"	65	40	A.GST011	T10F	1.2 Nm	7	
670P.DT20	20		65	40	A.GST012	T10F	1.2 Nm	7	R/L DT.7 ...
670P.DT22	22		65	40	A.GST012	T10F	1.2 Nm	7	
670P.DT25	25		65	40	A.GST013	T10F	1.2 Nm	7	
670P.DT254	25.4	1"	65	40	A.GST013	T10F	1.2 Nm	7	

Achtung: nur für Schneiden Typ DT geeignet

attention: only usable for inserts type DT

* Achtung: nicht für Ultramini geeignet
attention: not suitable for Ultramini

Bestellbeispiel:
660P.DT12

order-example:
660P.DT12

TYP DT

Multifunktionswerkzeug
zum Bohren und Ausdrehen

Multifunctional tool
drilling and boring

Typ 680P.DT

Klemmhalter,
durch tiefere Werkzeugspannung
optimiert für Schneideinsatz Typ DT

toolholder,
by deeper insert clamping
optimized for insert type DT

Ø 12 - 25.4 mm
für Schneideinsatz mit
D min. 7.7 mm

Ø 12 - 25.4 mm
for insert with
D min. 7.7 mm

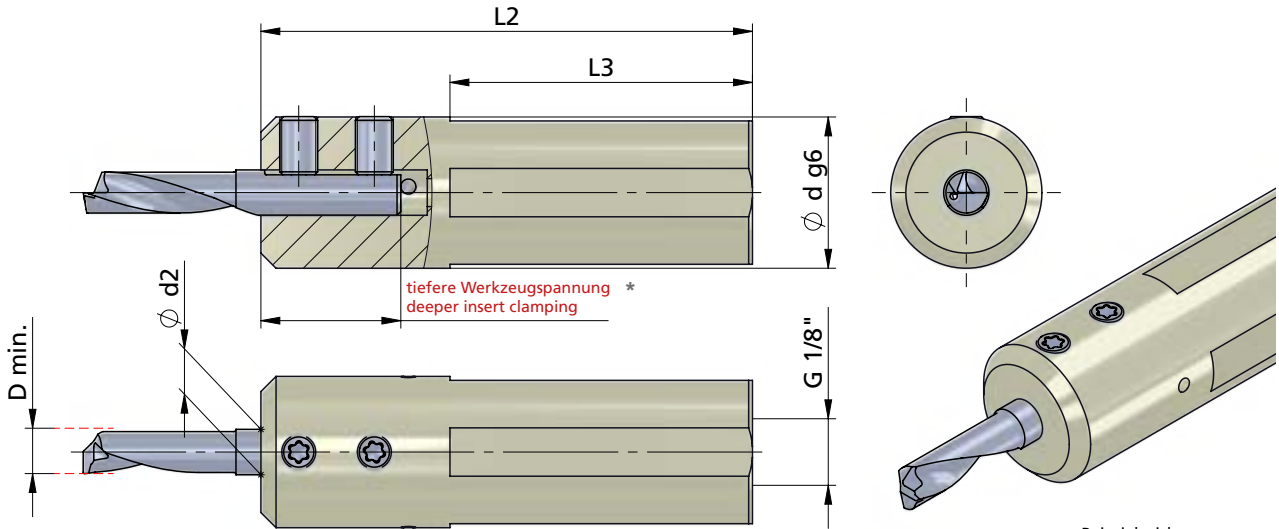

Beispielzeichnung
exemplary application

Klemmhalter für rechte und linke
Schneideinsätze einsetzbar

toolholder for right and left
inserts usable

Abmessungen in mm

dimensions in mm



Bestellnummer part number	Ø d g6	Ø d (inch)	L2	L3	Spannschraube screw	Schraubenschlüssel wrench	Anzugs- drehmoment torque	Ø d2 ≤ Ø d h6	Schneideinsatz Typ insert type
680P.DT12	12		65	35	A.GST011	T10F	1.2 Nm	8	
680P.DT16	16		65	38	A.GST010	T10F	1.2 Nm	8	
680P.DT1905	19.05	3/4"	65	38	A.GST011	T10F	1.2 Nm	8	
680P.DT20	20		65	38	A.GST011	T10F	1.2 Nm	8	R/L DT.8 ...
680P.DT22	22		65	38	A.GST011	T10F	1.2 Nm	8	
680P.DT25	25		65	38	A.GST012	T10F	1.2 Nm	8	
680P.DT25.4	25.4	1"	65	38	A.GST013	T10F	1.2 Nm	8	

Achtung: nur für Schneiden Typ DT geeignet

attention: only usable for inserts type DT

* Achtung: nicht für Ultramini geeignet
attention: not suitable for Ultramini

TYP DT

Multifunktionswerkzeug
zum Bohren und Ausdrehen

Multifunctional tool
drilling and boring

Typ DT

Bohren und Ausdrehen

D min. 2.0 - 7.7 mm

drilling and boring

D min. 2.0 - 7.7 mm

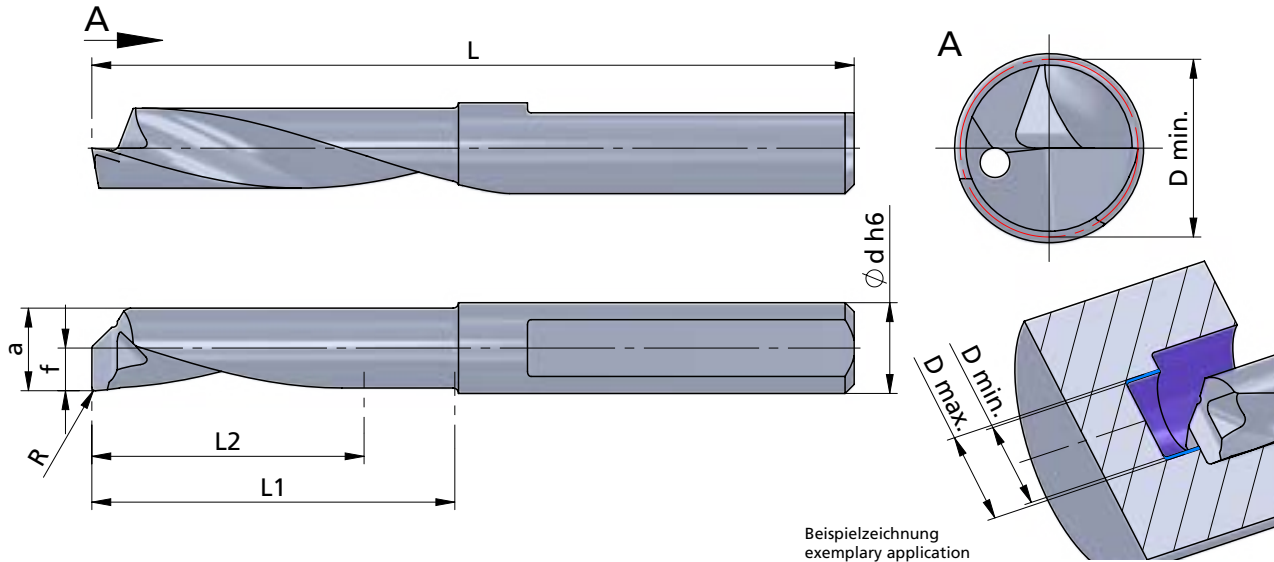

Beispielzeichnung
exemplary application

Rechts (R): wie gezeichnet
Links (L): spiegelbildlich

righthand (R): as shown
lefthand version (L): mirror image

Abmessungen in mm

dimensions in mm



Bestellnummer part number	R	f	a	L	L1 max. Ausdrehtiefe max. boring depth	L2 max. Bohrungstiefe max. drilling depth	D min. (Bohren / drilling)	D max. (Bohren / drilling)	Ø d h6	K10F CN45F AL41F P07C	Klemmhalter Typ toolholder type
R/ DT.2-8R05	0.05	1.0	1.9	40	8	8	2.0	2.0	4	●	640.DT ... 640P.DT ... UM600H...4
R/ DT.2-8R10	0.10	1.0	1.9	40	8	8	2.0	2.0	4	●	
R/ DT.3-10R05	0.05	0.9	2.72	37	10	10	2.9	3.0	4	●	
R/ DT.3-10R10	0.10	0.9	2.72	37	10	10	2.9	3.0	4	●	
R/L DT.3-10	0.20	0.9	2.72	37	10	10	2.9	3.0	4	●	
R/ DT.3-13R05	0.05	0.9	2.72	40	13	13	2.9	3.0	4	●	
R/ DT.3-13R10	0.10	0.9	2.72	40	13	13	2.9	3.0	4	●	
R/L DT.3-13	0.20	0.9	2.72	40	13	13	2.9	3.0	4	●	
R/ DT.4-15R10	0.10	1.85	3.55	37	15	10	3.7	4.0	4	●	
R/L DT.4-15	0.20	1.85	3.55	37	15	10	3.7	4.0	4	●	
R/L DT.4-20	0.20	1.85	3.55	42	20	16	3.7	4.0	4	●	
↳ ...											

Weitere HM Sorten können Sie in der Sortenübersicht im Kapitel "Technische Hinweise" und der Preisliste finden.

Bestellbeispiel:
für rechte Ausführung und Sorte
RDT.2-8R05/AL41F

weitere Informationen:

- siehe Technische Hinweise

more informations:

- look at the Technical Instructions

More carbide grades you can find in the grades summary in the chapter "technical instructions" and in the price list.

order-example:
righthand version and grade
RDT.2-8R05/AL41F

TYP DT

Multifunktionswerkzeug
zum Bohren und Ausdrehen

Multifunctional tool
drilling and boring

Typ DT

Bohren und Ausdrehen

D min. 2.0 - 7.7 mm

drilling and boring

D min. 2.0 - 7.7 mm

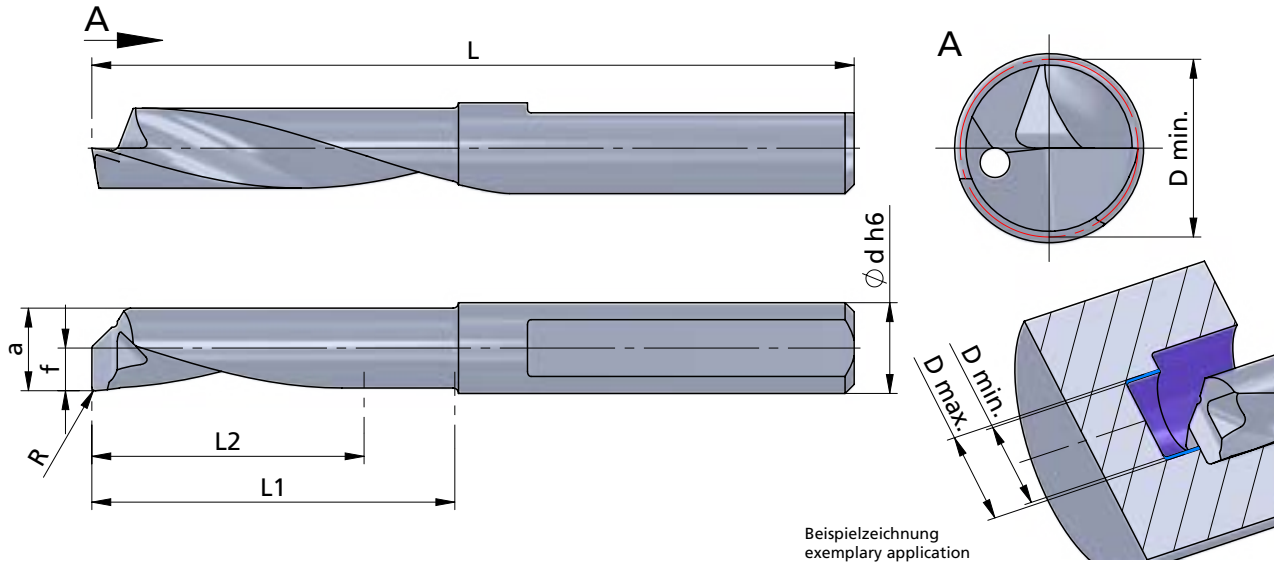

Beispielzeichnung
exemplary application

Rechts (R): wie gezeichnet
Links (L): spiegelbildlich

righthand (R): as shown
lefthand version (L): mirror image

Abmessungen in mm

dimensions in mm



Bestellnummer part number	R	f	a	L	L1 max. Ausdrehtiefe max. boring depth	L2 max. Bohrungstiefe max. drilling depth	D min. (Bohren / drilling)	D max. (Bohren / drilling)	Ø d h6	K10F	CN45F	AL41F	P07C	Klemmhalter Typ toolholder type
R/ DT.5-15R10	0.10	2.35	4.55	37	15	10	4.7	5.0	5		●			
R/L DT.5-15	0.20	2.35	4.55	37	15	10	4.7	5.0	5		●			650.DT ... 650P.DT ... UM600H...5
R/ DT.5-20R10	0.10	2.35	4.55	42	20	15	4.7	5.0	5		●			
R/L DT.5-20	0.20	2.35	4.55	42	20	15	4.7	5.0	5		●			
R/L DT.5-25	0.20	2.35	4.55	47	25	20	4.7	5.0	5		●			
R/ DT.6-15R10	0.10	2.85	5.55	37	15	10	5.7	6.0	6		●			
R/L DT.6-15	0.20	2.85	5.55	37	15	10	5.7	6.0	6		●			
R/ DT.6-20R10	0.10	2.85	5.55	42	20	15	5.7	6.0	6		●			
R/L DT.6-20	0.20	2.85	5.55	42	20	15	5.7	6.0	6		●			660.DT ... 660P.DT ... UM600H...6
R/L DT.6-25	0.20	2.85	5.55	47	25	20	5.7	6.0	6		●			
R/L DT.6-30	0.20	2.85	5.55	52	30	25	5.7	6.0	6		●			
↳ ...														

Weitere HM Sorten können Sie in der Sortenübersicht im Kapitel "Technische Hinweise" und der Preisliste finden.

weitere Informationen:

- siehe Technische Hinweise

More carbide grades you can find in the grades summary in the chapter "technical instructions" and in the price list.

more informations:

- look at the Technical Instructions

order-example:
righthand version and grade
RDT.5-15R10/AL41F

Bestellbeispiel:
für rechte Ausführung und Sorte
RDT.5-15R10/AL41F

TYP DT

Multifunktionswerkzeug
zum Bohren und Ausdrehen

Multifunctional tool
drilling and boring

Typ DT

Bohren und Ausdrehen

D min. 2.0 - 7.7 mm

drilling and boring

D min. 2.0 - 7.7 mm

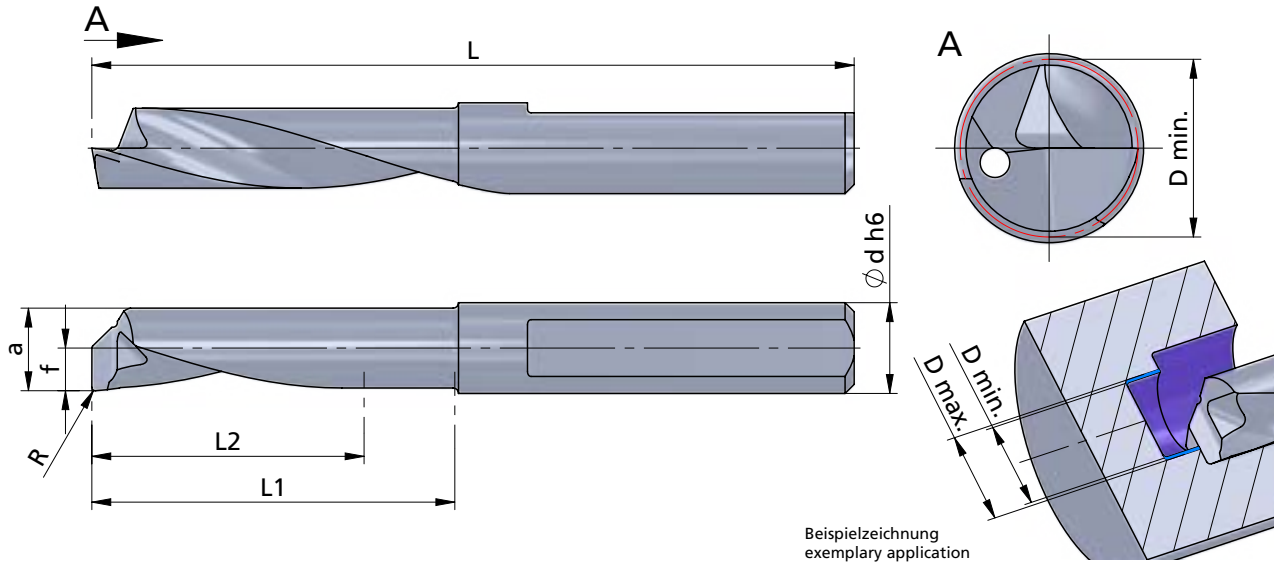

Beispielzeichnung
exemplary application

Rechts (R): wie gezeichnet
Links (L): spiegelbildlich

righthand (R): as shown
lefthand version (L): mirror image

Abmessungen in mm

dimensions in mm



Bestellnummer part number	R	f	a	L	L1 max. Ausdrehtiefe max. boring depth	L2 max. Bohrungstiefe max. drilling depth	D min. (Bohren / drilling)	D max. (Bohren / drilling)	Ø d h6	K10F CN45F AL41F P07C	Klemmhalter Typ toolholder type
R/L DT.7-20	0.2	3.35	6.55	42	20	15	6.7	7.0	7	●	670.DT ... 670P.DT ... UM600H...7
R/L DT.7-25	0.2	3.35	6.55	47	25	20	6.7	7.0	7	●	
R/L DT.7-30	0.2	3.35	6.55	52	30	25	6.7	7.0	7	●	
R/L DT.7-35	0.2	3.35	6.55	57	35	30	6.7	7.0	7	●	
R/L DT.8-25	0.2	3.85	7.55	50	25	20	7.7	8.0	8	●	680.DT ... 680P.DT ...
R/L DT.8-30	0.2	3.85	7.55	55	30	25	7.7	8.0	8	●	
R/L DT.8-35	0.2	3.85	7.55	60	35	30	7.7	8.0	8	●	
R/L DT.8-40	0.2	3.85	7.55	65	40	35	7.7	8.0	8	●	

Weitere HM Sorten können Sie in der Sortenübersicht im Kapitel "Technische Hinweise" und der Preisliste finden.

weitere Informationen:

- siehe Technische Hinweise

More carbide grades you can find in the grades summary in the chapter "technical instructions" and in the price list.

Bestellbeispiel:
für rechte Ausführung und Sorte
RDT.7-20/AL41F

more informations:

- look at the Technical Instructions

order-example:
righthand version and grade
RDT.7-20/AL41F

TYP DT MAX

Multifunktionswerkzeug
zum Bohren und Ausdrehen

Multifunctional tool
drilling and boring

Typ H.MDT

Klemmhalter,
Stechtiefe 1,5 x D

toolholder,
cutting depth 1,5 x D

D min. 7.85 bis D max. 33 mm
Stechtiefe 12 - 48 mm

D min. 7.85 up to D max. 33 mm
cutting depth 12 - 48 mm

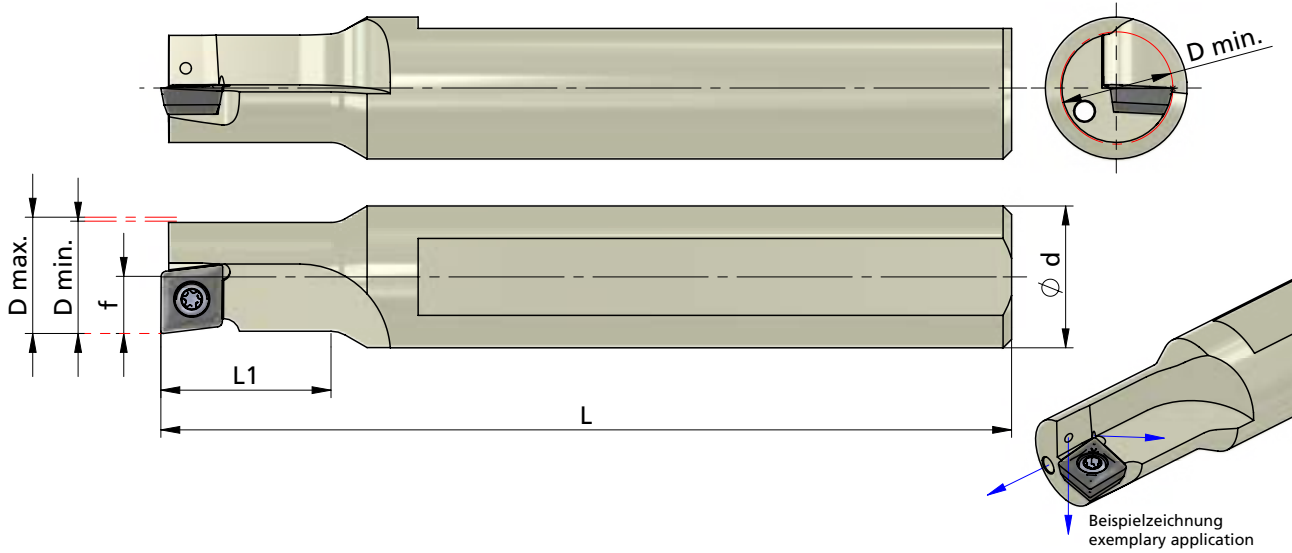

Rechts (R): wie gezeichnet
Links (L): spiegelbildlich

Rechte Schneidpl. in rechtem Halter
Linke Schneidpl. in linkem Halter *

Abmessungen in mm

righthand version (R): as shown
lefthand version (L): mirror image

use RH insert in RH tool holder and
LH insert in LH tool holder *

dimensions in mm



Bestellnummer part number	D min.	D max.	$\varnothing d$	L	L1	f	Spannschraube screw	Schraubenschlüssel wrench	Anzugs- drehmoment torque	für Schneideinsatz use with insert
R/L H.MDT08.150.04	7.85	8.3	12	80	12.0	4.0	A.SPS012	T6F-P	0.4 Nm	* MDR.E040204 / * MDL.E040204
R/L H.MDT10.150.05	9.85	10.5	12	90	15.0	5.0	A.SPS013	T6F-P	0.7 Nm	MDN.E050204 / MDN.F050204
R/L H.MDT12.150.06	11.85	12.5	16	100	18.0	6.0	A.SPS014	T7F-P	1.0 Nm	MDN.E060204 / MDN.F060204
R/L H.MDT14.150.07	13.85	14.5	16	110	21.0	7.0	A.SPS015	T8F-P	1.2 Nm	MDN.E070304 / MDN.F070304
R/L H.MDT16.150.08	15.85	16.5	20	125	24.0	8.0	A.SPS019	T9F-P	2.2 Nm	MDN.E080304 / MDN.F080304
↳ ...										

TYP DT MAX

Multifunktionswerkzeug
zum Bohren und Ausdrehen

Multifunctional tool
drilling and boring

Typ H.MDT

Klemmhalter,
Stechtiefe 1,5 x D

toolholder,
cutting depth 1,5 x D

D min. 7.85 bis D max. 33 mm
Stechtiefe 12 - 48 mm

D min. 7.85 up to D max. 33 mm
cutting depth 12 - 48 mm

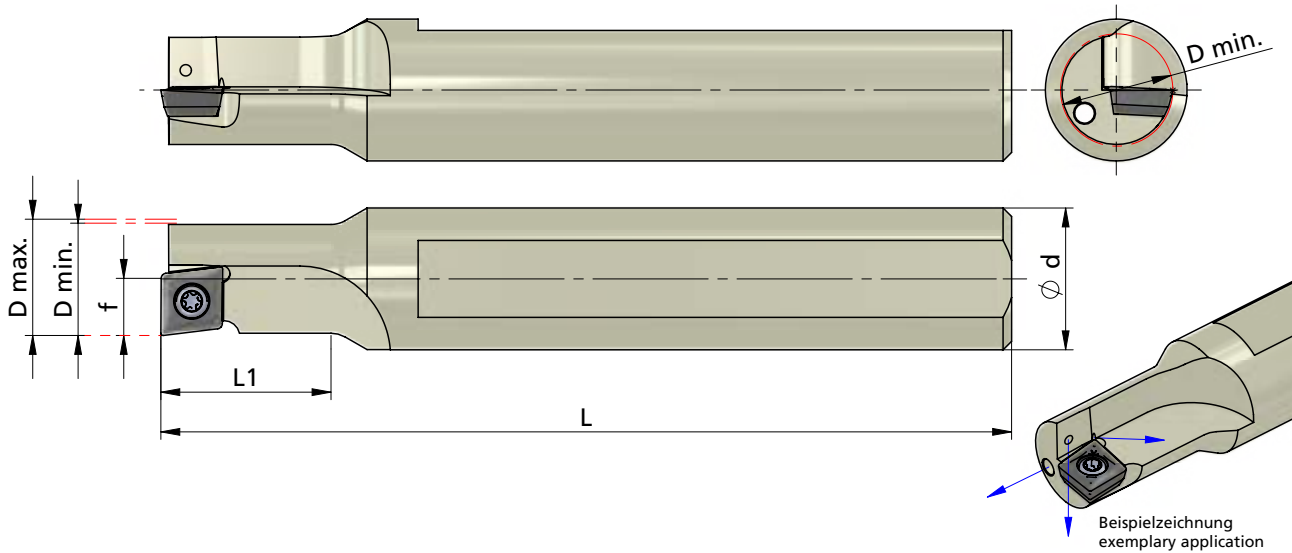

Rechts (R): wie gezeichnet
Links (L): spiegelbildlich

righthand version (R): as shown
lefthand version (L): mirror image

Abmessungen in mm

dimensions in mm



Bestellnummer part number	D min.	D max.	Ø d	L	L1	f	Spannschraube screw	Schraubenschlüssel wrench	Anzugs- drehmoment torque	für Schneideinsatz use with insert
⋮ ↘										
R/L H.MDT18.150.09	17.85	18.5	25	135	27.0	9.0	A.SPS019	T9F-P	2.2 Nm	MDN.E090404 / MDN.F090404
R/L H.MDT20.150.10	19.8	20.5	25	150	30.0	10.0	A.SPS020	T15F-P	3.2 Nm	MDN.E100404 / MDN.E100408 / MDN.F100404
R/L H.MDT25.150.13	24.8	25.8	32	180	37.5	12.5	A.SPS025	T20F-P	5.0 Nm	MDN.E130504 / MDN.E130508 / MDN.F130504
R/L H.MDT32.150.16	31.8	33.0	40	200	48.0	16.0	A.SPS025	T20F-P	5.0 Nm	MDN.E170608 / MDN.F170608

TYP DT MAX

Multifunktionswerkzeug
zum Bohren und Ausdrehen

Multifunctional tool
drilling and boring

Typ H.MDT

Klemmhalter,
Stechtiefe 2.25 x D

toolholder,
cutting depth 2.25 x D

D min. 7.85 bis D max. 33 mm
Stechtiefe 18 - 72 mm

D min. 7.85 up to D max. 33 mm
cutting depth 18 - 72 mm

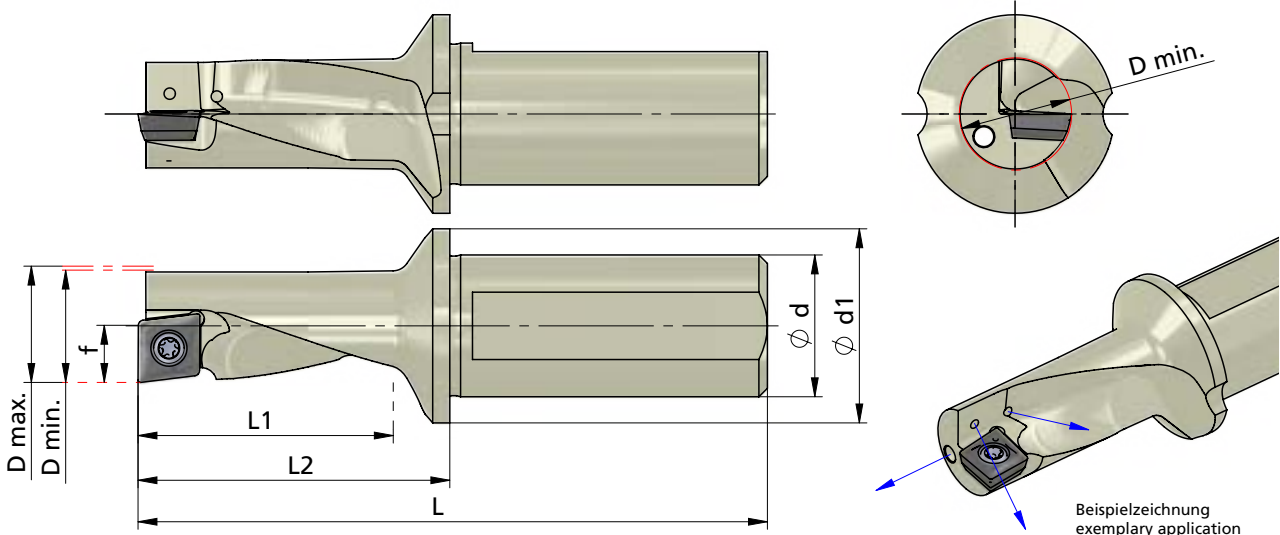

Rechts (R): wie gezeichnet
Links (L): spiegelbildlich

Rechte Schneidpl. in rechtem Halter
Linke Schneidpl. in linkem Halter *

Abmessungen in mm

righthand version (R): as shown
lefthand version (L): mirror image

use RH insert in RH tool holder and
LH insert in LH tool holder *

dimensions in mm



Bestellnummer part number	D min.	D max.	Ø d	Ø d1	L	L1	L2	f	Spannschraube screw	Schraubenschlüssel wrench	Anzugs- drehmoment torque	für Schneideinsatz use with insert
R/L H.MDT08.225.04	7.85	8.3	10	15	60.0	18.0	22	4.0	A.SPS012	T6F-P	0.4 Nm	* MDR.E040204 / * MDL.E040204
R/L H.MDT10.225.05	9.85	10.5	12	18	69.5	22.5	27.5	5.0	A.SPS013	T6F-P	0.7 Nm	MDN.E050204 / MDN.F050204
R/L H.MDT12.225.06	11.85	12.5	16	22	78.0	27.0	33	6.0	A.SPS014	T7F-P	1.0 Nm	MDN.E060204 / MDN.F060204
R/L H.MDT14.225.07	13.85	14.5	16	23	83.5	31.5	38.5	7.0	A.SPS015	T8F-P	1.2 Nm	MDN.E070304 / MDN.F070304
R/L H.MDT16.225.08	15.85	16.5	20	28	94.0	36.0	44	8.0	A.SPS019	T9F-P	2.2 Nm	MDN.E080304 / MDN.F080304
↳ ...												

TYP DT MAX

Multifunktionswerkzeug
zum Bohren und Ausdrehen

Multifunctional tool
drilling and boring

Typ H.MDT

Klemmhalter,
Stechtiefe 2.25 x D

toolholder,
cutting depth 2.25 x D

D min. 7.85 bis D max. 33 mm
Stechtiefe 18 - 72 mm

D min. 7.85 up to D max. 33 mm
cutting depth 18 - 72 mm

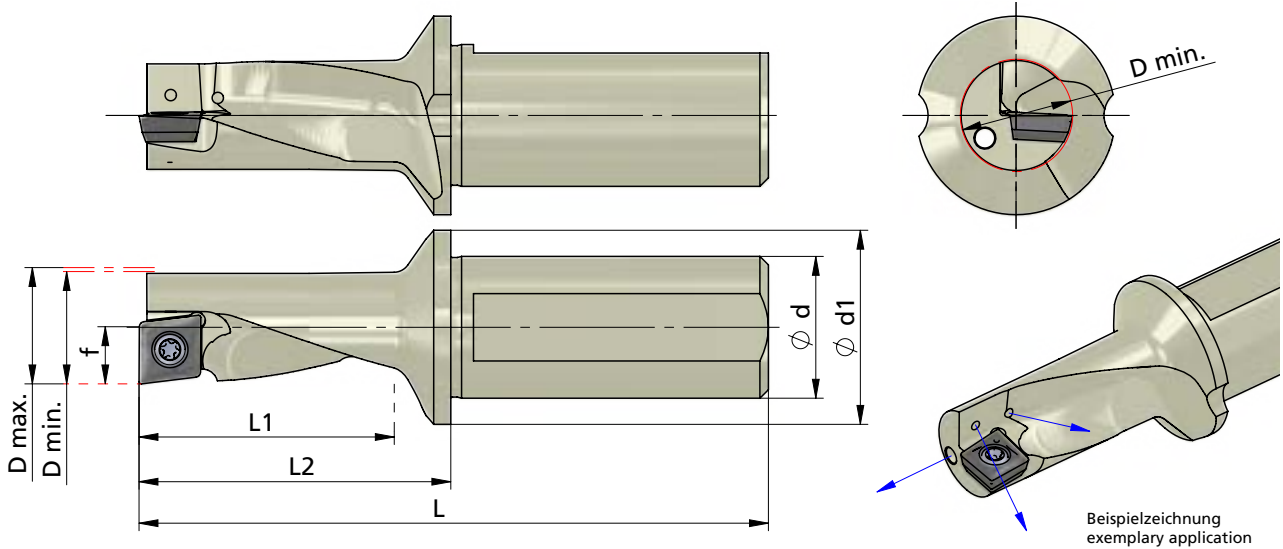

Rechts (R): wie gezeichnet
Links (L): spiegelbildlich

righthand version (R): as shown
lefthand version (L): mirror image

Abmessungen in mm

dimensions in mm



Bestellnummer part number	D min.	D max.	Ø d	Ø d1	L	L1	L2	f	Spannschraube screw	Schraubenschlüssel wrench	Anzugs- drehmoment torque	für Schneideinsatz use with insert
⋮ ↘												
R/L H.MDT18.225.09	17.85	18.5	25	36	109.5	40.5	53.5	9.0	A.SPS019	T9F-P	2.2 Nm	MDN.E090404 / MDN.F090404
R/L H.MDT20.225.10	19.8	20.5	25	35	111.0	45.0	55	10.0	A.SPS020	T15F-P	3.2 Nm	MDN.E100404 / MDN.E100408 / MDN.F100404
R/L H.MDT25.225.13	24.8	25.8	32	44	129.0	56.5	69	12.5	A.SPS025	T20F-P	5.0 Nm	MDN.E130504 / MDN.E130508 / MDN.F130504
R/L H.MDT32.225.16	31.8	33.0	40	54	158.0	72.0	88	16.0	A.SPS025	T20F-P	5.0 Nm	MDN.E170608 / MDN.F170608

TYP DT MAX

Multifunktionswerkzeug
zum Bohren und Ausdrehen

Multifunctional tool
drilling and boring

Typ MDR.E / MDL.E / MDN.E

Bohren und Ausdrehen

D min. 7.85 bis D max. 33 mm

drilling and boring

D min. 7.85 up to D max. 33 mm

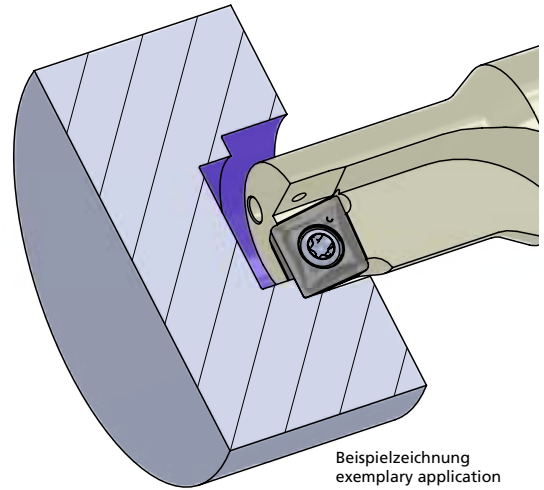
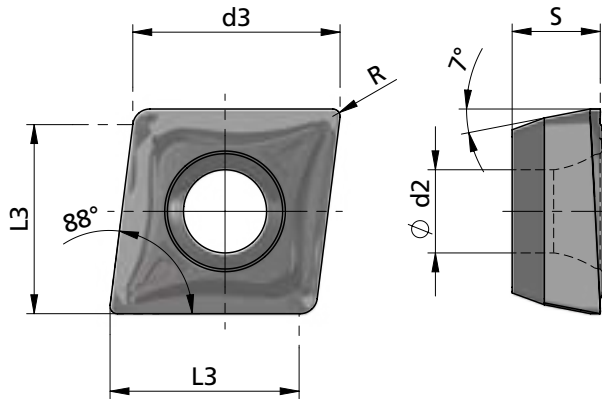

Beispielzeichnung
exemplary application

Rechts (R): wie gezeichnet
Links (L): spiegelbildlich

Rechte Schneidpl. in rechtem Halter
Linke Schneidpl. in linkem Halter *

Abmessungen in mm

righthand version (R): as shown
lefthand version (L): mirror image

use RH insert in RH tool holder and
LH insert in LH tool holder *

dimensions in mm

Bestellnummer part number	d3	L3	S	R	d2	P04C	VC10	Klemhalter Typ toolholder type	
MDR.E040204 * (rechts / right)	4.5	4.0	1.80	0.4	2.10	●	●	RH.MDT08.150.04	(rechts / right)
								RH.MDT08.225.04	(rechts / right)
MDL.E040204 * (links / left)	4.5	4.0	1.80	0.4	2.10	●	●	LH.MDT08.150.04	(links / left)
								LH.MDT08.225.04	(links / left)
MDN.E050204	5.8	5.0	2.10	0.4	2.25	●	●	R/L H.MDT10.150.05 /	R/L H.MDT10.225.05
MDN.E060204	6.5	6.0	2.92	0.4	2.50	●	●	R/L H.MDT12.150.06 /	R/L H.MDT12.225.06
MDN.E070304	7.6	7.0	3.87	0.4	2.80	●	●	R/L H.MDT14.150.07 /	R/L H.MDT14.225.07
MDN.E080304	8.5	8.0	3.87	0.4	3.40	●	●	R/L H.MDT16.150.08 /	R/L H.MDT16.225.08
MDN.E090404	9.6	9.0	4.66	0.4	3.40	●	●	R/L H.MDT18.150.09 /	R/L H.MDT18.225.09
MDN.E100404	10.6	10.0	4.66	0.4	4.40	●	●	R/L H.MDT20.150.10 /	R/L H.MDT20.225.10
MDN.E100408	10.6	10.0	4.66	0.8	4.40	●	●	R/L H.MDT20.150.10 /	R/L H.MDT20.225.10
MDN.E130504	13.5	12.5	5.45	0.4	5.30	●	●	R/L H.MDT25.150.13 /	R/L H.MDT25.225.13
MDN.E130508	13.5	12.5	5.45	0.8	5.30	●	●	R/L H.MDT25.150.13 /	R/L H.MDT25.225.13
MDN.E170608	17.5	16.0	6.25	0.8	5.30	●	●	R/L H.MDT32.150.16 /	R/L H.MDT32.225.16

Weitere HM Sorten können Sie in der Sortenübersicht im Kapitel "Technische Hinweise" und der Preisliste finden.

weitere Informationen:

- siehe Technische Hinweise

More carbide grades you can find in the grades summary in the chapter "technical instructions" and in the price list.

Bestellbeispiel:
für rechte Ausführung und Sorte
MDR.E040204/P04C

more informations:

- look at the Technical Instructions

order-example:
righthand version and grade
MDR.E040204/P04C

TYP DT MAX

Multifunktionswerkzeug
zum Bohren und Ausdrehen

Multifunctional tool
drilling and boring

Typ MDN.F

Bohren und Ausdrehen
für Aluminium

drilling and boring
for aluminium

D min. 7.85 bis D max. 33 mm

D min. 7.85 up to D max. 33 mm

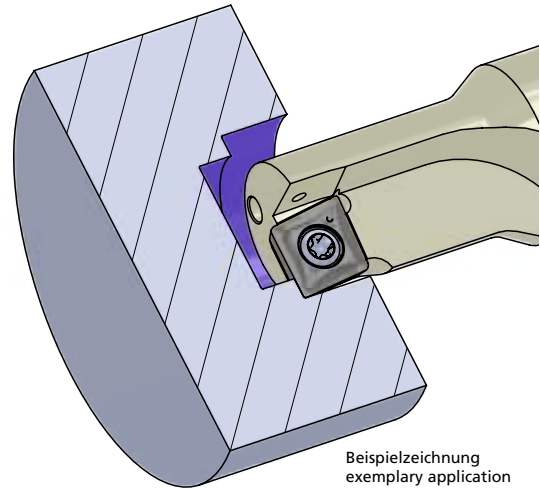
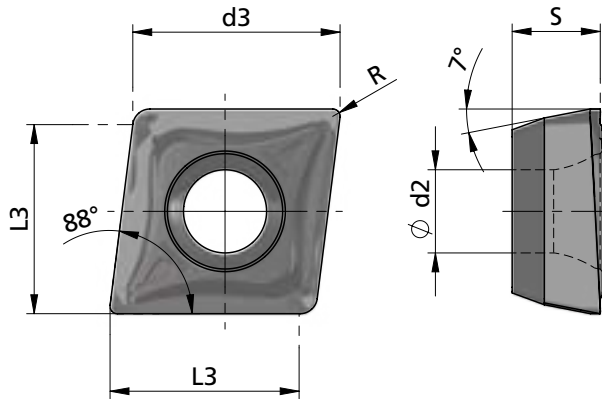

Rechts (R): wie gezeichnet
Links (L): spiegelbildlich

righthand version (R): as shown
lefthand version (L): mirror image

Abmessungen in mm

dimensions in mm



Bestellnummer part number	d3	L3	S	R	d2	K06P	Klemmhalter Typ toolholder type
MDN.F050204	5.8	5.0	2.10	0.4	2.25	●	R/L H.MDT10.150.05 / R/L H.MDT10.225.05
MDN.F060204	6.5	6.0	2.92	0.4	2.50	●	R/L H.MDT12.150.06 / R/L H.MDT12.225.06
MDN.F070304	7.6	7.0	3.87	0.4	2.80	●	R/L H.MDT14.150.07 / R/L H.MDT14.225.07
MDN.F080304	8.5	8.0	3.87	0.4	3.40	●	R/L H.MDT16.150.08 / R/L H.MDT16.225.08
MDN.F090404	9.6	9.0	4.66	0.4	3.40	●	R/L H.MDT18.150.09 / R/L H.MDT18.225.09
MDN.F100404	10.6	10.0	4.66	0.4	4.40	●	R/L H.MDT20.150.10 / R/L H.MDT20.225.10
MDN.F130504	13.5	12.5	5.45	0.4	5.30	●	R/L H.MDT25.150.13 / R/L H.MDT25.225.13
MDN.F170608	17.5	16.0	6.25	0.8	5.30	●	R/L H.MDT32.150.16 / R/L H.MDT32.225.16

Weitere HM Sorten können Sie in der Sortenübersicht im Kapitel "Technische Hinweise" und der Preisliste finden.

weitere Informationen:

- siehe Technische Hinweise

more informations:

- look at the Technical Instructions

More carbide grades you can find in the grades summary in the chapter "technical instructions" and in the price list.

Bestellbeispiel:
MDR.F040204/K060P

order-example:
MDR.F040204/K060P

TYP DT

Multifunktionswerkzeug
zum Bohren und Ausdrehen

Multifunctional tool
drilling and boring

Technische Hinweise

Hartmetallsorten und Beschichtungen

Technical instructions,
carbide grades and coatings

Typ DT

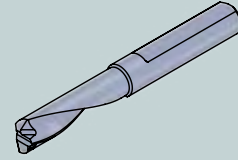

K10F

Universell einsetzbares Feinkornhartmetall mit guter Verschleißfestigkeit. Unbeschichtet geeignet für Anwendungen mit niedrigen und mittleren Schnittgeschwindigkeiten, sowie die Bearbeitung von NE-Metallen.

All purpose micrograin carbide with good abrasion resistance. Uncoated for applications with low or medium cutting speeds and machining of non-ferrous materials.

P04C

Optimierte, sehr universell einsetzbare TIALN-Beschichtung mit hoher Temperaturbeständigkeit bei hoher Härte. Sehr gut geeignet auch für NE-Metalle.

Optimized TIALN coating - very universal with a high resistance to high temperature and hardness. Very suitable also for non-ferrous metals.

AL41F

Sehr universell einsetzbare TIALN-Beschichtung mit hoher Temperaturbeständigkeit bei hoher Härte. Sehr gut geeignet auch für NE-Metalle.

TIALN coating - very universal with a high resistance to high temperature and hardness. Very suitable also for non-ferrous metals.

CN45F

Universell einsetzbare PVD-TIN-Beschichtung. Diese Allround-Sorte ist für niedrige und mittlere Schnittgeschwindigkeiten mit Einschränkung bei NE-Metallen.

PVD-TIN coating - all purpose, all around grade is suitable for low and medium cutting speed with restrictions on non-ferrous materials.

P18C

Universell einsetzbare Hochleistungsschicht mit hoher Oxidationsbeständigkeit, Verschleißfestigkeit und Warmhärte.

Very universal high performance coating with high oxidation resistance, wear resistance and hot hardness resistance.

P07C

Beschichtung für die Bearbeitung von Titan, Edelstahl und Molybdän.

Coating to machine titanium, stainless steel and molybdenum.



TYP DT

Multifunktionswerkzeug
zum Bohren und Ausdrehen

Multifunctional tool
drilling and boring

Technische Hinweise

Hartmetallsorten und Beschichtungen

Technical instructions,
carbide grades and coatings

Typ DT

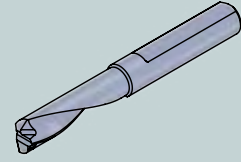

XC2A

Beschichtung mit einer exzellenten Warmhärte, Oxidationsbeständigkeit und thermischen Isolationsfähigkeit. Ideal für Hartzerspannung >60HRC

Coating with excellent hot hardness, high oxidation resistance and thermal insulation capacity. Ideal for hard machining >60 HRC.

P03C

Beschichtung für die Bearbeitung von schwer zerspanbaren Materialien. Sehr gut auch für die Trockenbearbeitung geeignet.

Coating for materials which are difficult to machine. Perfect to use for dry machining.

PD2F

Beschichtung für den universellen Einsatz bei niedrigen und mittleren Schnittgeschwindigkeiten.

Coating for universal use with medium and low speed.

NEME

Beschichtung für die Bearbeitung von Aluminium, Al-Legierungen, NE-Metallen und Kompositwerkstoffen.

Coating for machining aluminium, Al alloys, non-ferrous metals and composite materials.



TYP DT MAX

Multifunktionswerkzeug
zum Bohren und Ausdrehen

Multifunctional tool
drilling and boring

Technische Hinweise

Hartmetallsorten und Beschichtungen

Technical instructions,
carbide grades and coatings

Typ DT MAX

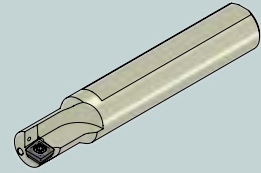

K06P

Unbeschichtete Hartmetallsorte mit 6% Kobalt. Geeignet für Aluminium und NE-Metallbearbeitung, mit polierter Spanfläche. (Aktuell nur für System DT MAX erhältlich.)

Uncoated carbide grade with 6% cobalt. For machining aluminium and non-ferrous materials, with polished cutting surface. (Only for the system DT MAX available.)

P04C

Optimierte, sehr universell einsetzbare TIALN-Beschichtung mit hoher Temperaturbeständigkeit bei hoher Härte. Sehr gut geeignet auch für NE-Metalle.

Optimized TIALN coating - very universal with a high resistance to high temperature and hardness. Very suitable also for non-ferrous metals.

VC10

Verschleißfeste CVD-Beschichtung für die Guss- und Stahlbearbeitung. Feinkornsorte mit 10.5% Kobalt.

Wear-resistant CVD-coating for machining steel and cast iron. Fine grain carbide with 10.5% cobalt.



TYP DT

Multifunktionswerkzeug
zum Bohren und Ausdrehen

Multifunctional tool
drilling and boring

Technische Hinweise

Allgemeine Informationen über
Schnitttiefe und Vorschub für Typ DT

General instructions about
cutting depth and feed of type DT

Schnitttiefe und Vorschub für Typ DT

Cutting depth and feed of type DT

		Bohren / drilling							
Typ DT Größe / size		Vorschub f in mm/U / feed f in mm/Rev.							
R/ DT.2-	8	0.002 - 0.008							
R/L DT.3-	10	0.0025 - 0.0125							
	13	0.0025 - 0.010							
R/L DT.4-	15	0.005 - 0.030							
	20	0.005 - 0.015							
R/L DT.5-	15	0.005 - 0.040							
	25	0.005 - 0.020							
R/L DT.6-	15	0.005 - 0.030							
	30	0.005 - 0.020							
R/L DT.7-	20	0.005 - 0.035							
	35	0.005 - 0.025							
R/L DT.8-	25	0.005 - 0.040							
	40	0.005 - 0.030							



		Ausdrehen / boring								
Typ DT Größe / size		Spantiefe a _p in mm / cutting depth a _p in mm								
		0.2	0.5	1,0	1,5	2.0	2.5	3.0	3.5	4.0
		Vorschub f in mm/U / feed f in mm/Rev.								
R/ DT.2-	8	0.01 - 0.04	0.01 - 0.02	(0.003-0.006)						
R/L DT.3-	10	0.02 - 0.07	0.02 - 0.07	0.02 - 0.05	0.005 - 0.01					
	13	0.02 - 0.05	0.02 - 0.05	0.005 - 0.03	0.005 - 0.01					
R/L DT.4-	15	0.04 - 0.1	0.04 - 0.1	0.04 - 0.1	0.03 - 0.07	0.01 - 0.05				
	20	0.04 - 0.1	0.04 - 0.1	0.03 - 0.08	0.01 - 0.05	0.005 - 0.025				
R/L DT.5-	15	0.04 - 0.1	0.04 - 0.1	0.04 - 0.1	0.03 - 0.08	0.02 - 0.06	0.01 - 0.04			
	25	0.04 - 0.1	0.04 - 0.1	0.03 - 0.09	0.02 - 0.06	0.01 - 0.04	0.005 - 0.025			
R/L DT.6-	15	0.04 - 0.1	0.04 - 0.1	0.04 - 0.1	0.04 - 0.1	0.03 - 0.08	0.02 - 0.06	0.01 - 0.04		
	30	0.04 - 0.1	0.04 - 0.1	0.03 - 0.09	0.02 - 0.06	0.01 - 0.04	0.01 - 0.03	0.005 - 0.03		
R/L DT.7-	20	0.04 - 0.1	0.04 - 0.1	0.04 - 0.1	0.04 - 0.1	0.04 - 0.1	0.03 - 0.08	0.02 - 0.06	0.01 - 0.04	
	35	0.04 - 0.1	0.04 - 0.1	0.04 - 0.1	0.03 - 0.08	0.02 - 0.06	0.01 - 0.04	0.01 - 0.03	0.01 - 0.02	
R/L DT.8-	25	0.04 - 0.1	0.04 - 0.1	0.04 - 0.1	0.04 - 0.1	0.04 - 0.1	0.04 - 0.1	0.03 - 0.08	0.02 - 0.06	0.01 - 0.04
	40	0.04 - 0.1	0.04 - 0.1	0.04 - 0.1	0.04 - 0.095	0.03 - 0.08	0.02 - 0.06	0.01 - 0.04	0.01 - 0.03	0.01 - 0.02

- f - Werte sind IK - Druck abhängig: - IK - Druck 10 - 30 bar → unterer Bereich der f - Werte auswählen
- IK - Druck 30 - 70 bar → obere Bereich der f - Werte auswählen

- außerdem sind die f - Werte materialabhängig

- f - measures are depending on cooling pressure: - cooling pressure 10 - 30 bar → choose lower range of f - measures
- cooling pressure 30 - 70 bar → choose upper range of f - measures

- furthermore f - measures are depending on material

TYP DT MAX

Multifunktionswerkzeug
zum Bohren und Ausdrehen

Multifunctional tool
drilling and boring

Technische Hinweise

Allgemeine Informationen über
Vorschub für Typ DT MAX

General instructions about
feed of type DT MAX

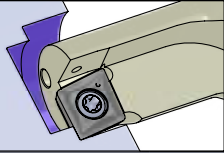

Vorschub für Typ DT MAX / feed of type DT MAX

Bohren / drilling

Typ DT MAX Größe / size		Vorschub f in mm/U / feed f in mm/Rev.					
R/L H.MDT08.	150.	0.01 - 0.04					
	225.	0.01 - 0.04					
R/L H.MDT10.	150.	0.01 - 0.05					
	225.	0.01 - 0.05					
R/L H.MDT12.	150.	0.01 - 0.05					
	225.	0.01 - 0.05					
R/L H.MDT14.	150.	0.01 - 0.07					
	225.	0.01 - 0.07					
R/L H.MDT16.	150.	0.02 - 0.08					
	225.	0.02 - 0.08					
R/L H.MDT18.	150.	0.03 - 0.09					
	225.	0.03 - 0.09					
R/L H.MDT20.	150.	0.03 - 0.10					
	225.	0.03 - 0.10					
R/L H.MDT25.	150.	0.03 - 0.12					
	225.	0.03 - 0.12					
R/L H.MDT32.	150.	0.05 - 0.15					
	225.	0.05 - 0.15					

- f - Werte sind IK - Druck abhängig: - IK - Druck 10 - 30 bar → unteres 1/3 der f - Werte auswählen
- IK - Druck 30 - 70 bar → obere Hälfte der f - Werte auswählen
- außerdem sind die f - Werte materialabhängig
- f - measures are depending on cooling pressure: - cooling pressure 10 - 30 bar → choose lower third of f - measures
- cooling pressure 30 - 70 bar → choose upper half of f - measures
- furthermore f - measures are depending on material

TYP DT MAX

Multifunktionswerkzeug
zum Bohren und Ausdrehen

Multifunctional tool
drilling and boring

Technische Hinweise

Allgemeine Informationen über
Schnitttiefe für Typ DT MAX

General instructions about
cutting depth of type DT MAX

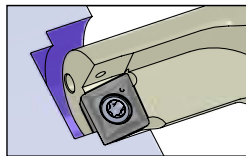

Schnitttiefe für Typ DT MAX / cutting depth of type DT MAX

Ausdrehen / boring

Typ DT MAX Größe / size		Spantiefe a_p in mm / cutting depth a_p in mm									
		1.0	2.0	2.5	3.0	3.5	4.0	4.5	5.0		
		Vorschub f in mm/U / feed f in mm/Rev.									
R/L H.MDT08.	150.	0.06 - 0.12	0.06 - 0.12	0.04 - 0.10	0.04 - 0.10	0.02 - 0.08	0.02 - 0.08				
	225.	0.06 - 0.12	0.04 - 0.10	0.02 - 0.08							
R/L H.MDT10.	150.	0.07 - 0.15	0.07 - 0.15	0.05 - 0.13	0.05 - 0.13	0.04 - 0.11	0.04 - 0.11	0.02 - 0.09	0.02 - 0.09		
	225.	0.07 - 0.15	0.05 - 0.13	0.03 - 0.11	0.02 - 0.09						
R/L H.MDT12.	150.	0.08 - 0.16	0.08 - 0.16	0.08 - 0.16	0.08 - 0.16	0.06 - 0.14	0.06 - 0.14	0.04 - 0.12	0.04 - 0.12		
	225.	0.08 - 0.16	0.08 - 0.16	0.06 - 0.14	0.04 - 0.12	0.02 - 0.10					
R/L H.MDT14.	150.	0.09 - 0.18	0.09 - 0.18	0.09 - 0.18	0.09 - 0.18	0.09 - 0.18	0.09 - 0.18	0.07 - 0.16	0.07 - 0.16		
	225.	0.09 - 0.18	0.09 - 0.18	0.07 - 0.16	0.05 - 0.14	0.04 - 0.13	0.02 - 0.11				
R/L H.MDT16.	150.	0.10 - 0.20	0.10 - 0.20	0.10 - 0.20	0.10 - 0.20	0.10 - 0.20	0.10 - 0.20	0.08 - 0.18	0.08 - 0.18		
	225.	0.10 - 0.20	0.10 - 0.20	0.09 - 0.19	0.07 - 0.17	0.05 - 0.15	0.03 - 0.13				
R/L H.MDT18.	150.	0.11 - 0.22	0.11 - 0.22	0.11 - 0.22	0.11 - 0.22	0.11 - 0.22	0.11 - 0.22	0.11 - 0.22	0.11 - 0.22		
	225.	0.11 - 0.22	0.11 - 0.22	0.11 - 0.22	0.09 - 0.20	0.07 - 0.18	0.05 - 0.16	0.03 - 0.14			
R/L H.MDT20.	150.	0.12 - 0.24	0.12 - 0.24	0.12 - 0.24	0.12 - 0.24	0.12 - 0.24	0.12 - 0.24	0.12 - 0.24	0.12 - 0.24		
	225.	0.12 - 0.24	0.12 - 0.24	0.12 - 0.24	0.12 - 0.24	0.10 - 0.22	0.08 - 0.20	0.06 - 0.18	0.04 - 0.16		
R/L H.MDT25.	150.	0.13 - 0.26	0.13 - 0.26	0.13 - 0.26	0.13 - 0.26	0.13 - 0.26	0.13 - 0.26	0.13 - 0.26	0.13 - 0.26		
	225.	0.13 - 0.26	0.13 - 0.26	0.13 - 0.26	0.13 - 0.26	0.13 - 0.26	0.12 - 0.25	0.10 - 0.23	0.08 - 0.21		
R/L H.MDT32.	150.	0.15 - 0.30	0.15 - 0.30	0.15 - 0.30	0.15 - 0.30	0.15 - 0.30	0.15 - 0.30	0.15 - 0.30	0.15 - 0.30		
	225.	0.15 - 0.30	0.15 - 0.30	0.15 - 0.30	0.15 - 0.30	0.15 - 0.30	0.15 - 0.30	0.14 - 0.29	0.12 - 0.27		

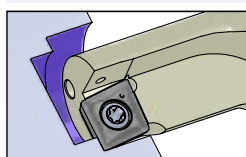

Schnitttiefe für Typ DT MAX / cutting depth of type DT MAX

Ausdrehen / boring

Typ DT MAX Größe / size		Spantiefe a_p in mm / cutting depth a_p in mm									
		5.5	6.0	7.0	8.0	9.0	10.0	12.0	14.0		
		Vorschub f in mm/U / feed f in mm/Rev.									
R/L H.MDT08.	150.										
	225.										
R/L H.MDT10.	150.										
	225.										
R/L H.MDT12.	150.	0.02 - 0.10	0.02 - 0.10								
	225.										
R/L H.MDT14.	150.	0.05 - 0.14	0.05 - 0.14	0.02 - 0.11							
	225.										
R/L H.MDT16.	150.	0.06 - 0.16	0.06 - 0.16	0.04 - 0.14	0.02 - 0.12						
	225.										
R/L H.MDT18.	150.	0.09 - 0.20	0.09 - 0.20	0.07 - 0.18	0.05 - 0.16	0.03 - 0.13					
	225.										
R/L H.MDT20.	150.	0.11 - 0.23	0.11 - 0.23	0.09 - 0.21	0.07 - 0.19	0.05 - 0.17	0.03 - 0.15				
	225.										
R/L H.MDT25.	150.	0.13 - 0.26	0.13 - 0.26	0.13 - 0.26	0.11 - 0.24	0.09 - 0.22	0.07 - 0.20	0.03 - 0.16			
	225.	0.06 - 0.19	0.04 - 0.17								
R/L H.MDT32.	150.	0.15 - 0.30	0.15 - 0.30	0.15 - 0.30	0.15 - 0.30	0.13 - 0.28	0.11 - 0.26	0.07 - 0.22	0.03 - 0.18		
	225.	0.10 - 0.25	0.08 - 0.23	0.05 - 0.20							





TYP DT

Multifunktionswerkzeug zum Bohren und Ausdrehen

Multifunctional tool drilling and boring

Technische Hinweise

Schnittdatenempfehlung: metrisch

Schnittgeschwindigkeit: V_c (m/min)
Vorschub: f (mm/U)

Technical instructions, speed and feed recommendation: metric

cutting speed: V_c (m/min)
feed: f (mm/rev)

Typ DT

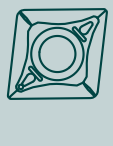
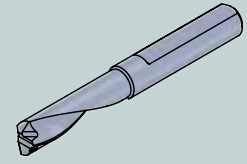

Werkstoffgruppe material group		Zusammensetzung composition		(Zug-)Festigkeit tensile strength	
ISO	Beschreibung / description	Gefüge / structure	Wärmebehandlung / heat treatment	Psi / N/mm ² (Rm) / HB / HRC	
P	Unlegierter Stahl unalloyed steel	ca.lapp. 0,15 % C	geglüht / annealed	61000 Psi / 420 N/mm ² / 125 HB	
		ca.lapp. 0,45 % C	geglüht / annealed	93000 Psi / 640 N/mm ² / 190 HB	
			vergütet / tempered	122000 Psi / 840 N/mm ² / 250 HB	
		ca.lapp. 0,75 % C	geglüht / annealed	132000 Psi / 910 N/mm ² / 270 HB	
			vergütet / tempered	146500 Psi / 1010 N/mm ² / 300 HB	
	Niedriglegierter Stahl low alloyed steel			geglüht / annealed	88500 Psi / 610 N/mm ² / 180 HB
				vergütet / tempered	135000 Psi / 930 N/mm ² / 275 HB
				vergütet / tempered	146500 Psi / 1010 N/mm ² / 300 HB
				vergütet / tempered	174000 Psi / 1200 N/mm ² / 375 HB
	Hochlegierter (Werkzeug-)Stahl highly alloyed steel			geglüht / annealed	99000 Psi / 680 N/mm ² / 200 HB
			gehärtet & angelassen / hardened & tempered	160000 Psi / 1100 N/mm ² / 300 HB	
Nichtrostender Stahl stainless steel			gehärtet & angelassen / hardened & tempered	189000 Psi / 1300 N/mm ² / 400 HB	
		ferritisch, martensitisch / ferritic, martensitic	geglüht / annealed	99000 Psi / 680 N/mm ² / 200 HB	
M	Nichtrostender Stahl stainless steel		martensitisch / martensitic	vergütet / tempered	117500 Psi / 810 N/mm ² / 250 HB
			austenitisch / austenitic	abgeschreckt / quenched	88500 Psi / 610 N/mm ² / 200 HB
			austenitisch / austenitic	vergütet / tempered	300 HB
			austenitisch, ferritisch / ferritic, martensitic (Duplex)		113000 Psi / 780 N/mm ² / 230 HB
K	Grauguss cast iron		perlitisch, ferritisch / pearlitic, ferritic	51000 Psi / 350 N/mm ² / 180 HB	
			perlitisch (martensitisch) / pearlitic (martensitic)	72500 Psi / 500 N/mm ² / 260 HB	
	Gusseisen mit Kugelgraphit cast iron with nodular graphite		ferritisch / ferritic		72500 Psi / 500 N/mm ² / 160 HB
			perlitisch / pearlitic		122500 Psi / 845 N/mm ² / 250 HB
	Temperguss malleable iron		ferritisch / ferritic		63800 Psi / 440 N/mm ² / 130 HB
		perlitisch / pearlitic		113000 Psi / 780 N/mm ² / 230 HB	
N	Aluminium - Knetlegierungen wrought aluminum alloys		nicht aushärtbar / uncurable	60 HB	
			aushärtbar / curable	ausgehärtet / cured	49000 Psi / 340 N/mm ² / 100 HB
	Aluminium - Gusslegierungen cast aluminum alloys		≤ 12% Si, nicht aushärtbar / uncurable		36250 Psi / 250 N/mm ² / 75 HB
			≤ 12% Si, aushärtbar / curable	ausgehärtet / cured	43500 Psi / 300 N/mm ² / 90 HB
			> 12% Si, nicht aushärtbar / uncurable		63800 Psi / 440 N/mm ² / 130 HB
	Kupfer und Kupferlegierungen (Bronze / Messing) copper and copper alloys (bronze / brass)		PB > 1 %, Automatenlegierungen / free cutting alloys		54500 Psi / 375 N/mm ² / 110 HB
		CuZn, CuSnZn		43500 Psi / 300 N/mm ² / 90 HB	
		CuSn, bleifrei & Elektrolitisch / lead free & electrolytic		49000 Psi / 340 N/mm ² / 100 HB	
	Magnesium &-Legierungen / Mg-alloys	Magnesium und -Legierungen / and -alloys		70 HB	
S	Warmfeste Legierungen heat-resistant alloys		Fe-Basis / Fe base	geglüht / annealed	99000 Psi / 680 N/mm ² / 200 HB
				ausgehärtet / cured	137750 Psi / 950 N/mm ² / 280 HB
			Ni- oder Co-Basis / Ni- or Co-Base	geglüht / annealed	122000 Psi / 840 N/mm ² / 250 HB
				ausgehärtet / cured	171000 Psi / 1180 N/mm ² / 350 HB
				gegossen / cast	156600 Psi / 1080 N/mm ² / 320 HB
	Titanlegierungen titanium alloys		Reintitan / pure titanium		58000 Psi / 400 N/mm ²
			Alpha- + Beta-Legierungen / -alloys	ausgehärtet / cured	152250 Psi / 1050 N/mm ²
		Beta-Legierungen / -alloys		203000 Psi / 1400 N/mm ² / 410 HB	
H	Gehärteter Stahl hardened steel		gehärtet & angelassen / hardened & tempered	46-55 HRC	
			gehärtet & angelassen / hardened & tempered	56-60 HRC	
			gehärtet & angelassen / hardened & tempered	61-65 HRC	
			gehärtet & angelassen / hardened & tempered	66-70 HRC	
	Hartguss / chilled cast iron		gegossen / cast	400 HB	
Gehärtetes Guss / hardened cast iron		gehärtet & angelassen / hardened & tempered	55 HRC		
O	Nichtmetallische Werkstoffe non-metallic materials		Kunststoffe, duroplastisch / plastics, duroplastic	≤ 21750 Psi / ≤ 150 N/mm ²	
			Kunststoffe, thermoplastisch / plastics, thermoplastic	≤ 14500 Psi / ≤ 100 N/mm ²	
			aramidfaserverstärkt / aramid fiber reinforced	≤ 145000 Psi / ≤ 1000 N/mm ²	
			glas/kohlefaserverstärkt / glas/carbon fiber reinforced	≤ 145000 Psi / ≤ 1000 N/mm ²	
			Graphit / graphite		

Richtige Schnittgeschwindigkeit ist in Abhängigkeit von Dimension und Anwendungssituation zu wählen.

The correct cutting speed must be selected depending on the dimension and application situation.

20 (10 - 50) bevorzugte Wahl / best choice
20 (10 - 50) bedingt möglich / conditionally possible

20 (10 - 50)
empfohlener Startwert
recommended starting value (bevorzugter Einsatzbereich)
(preferred application area)

weitere Informationen zu Vorschub und Schnitttiefe:
• siehe Technische Hinweise:
Allgemeine Informationen über Schnitttiefe und Vorschub Typ DT

more informations about feed and cutting depth:
• look at the technical instructions:
General instructions about cutting depth and feed type DT

TYP DT

Multifunktionswerkzeug zum Bohren und Ausdrehen

Multifunctional tool drilling and boring

Technische Hinweise

Schnittdatenempfehlung: metrisch

Technical instructions, speed and feed recommendation: metric

Schnittgeschwindigkeit: V_c (m/min)
Vorschub: f (mm/U)

cutting speed: V_c (m/min)
feed: f (mm/rev)

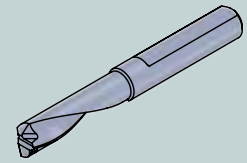

Typ DT

beispielhafte Werkstoffe exemplary materials

beispielhafte Werkstoffe exemplary materials				V_c Start (min. - max.)			
DIN	DIN-Code	DIN	DIN-Code	Bohren/drilling AL41F [m/min]	Drehen/boring AL41F [m/min]		
1.0401	C15	1.1141	Ck 15	90 (80 - 110)	140 (80 - 260)		
1.1191	C45E	1.0718	9 SMnPb 28	80 (70 - 90)	120 (70 - 230)		
1.1191	C45E	1.0535	C 55	60 (50 - 70)	90 (50 - 180)		
1.1223	C60R	1.0535	C 55	60 (50 - 70)	90 (50 - 180)		
1.1223	C60R	1.0727	45 S 20	50 (50 - 60)	80 (50 - 150)		
1.7131	16 MnCr 5	1.6587	17 CrNiMo6	60 (50 - 70)	90 (50 - 180)		
1.7131	16 MnCr 5	1.6587	17 CrNiMo6	50 (50 - 60)	80 (50 - 150)		
1.7225	42 CrMo 4	1.3505	100Cr6	50 (40 - 60)	70 (40 - 140)		
1.7225	42 CrMo 4	1.3505	100Cr6	40 (40 - 50)	70 (40 - 130)		
1.4021	X20Cr13	1.4034	X46Cr13	40 (40 - 50)	70 (40 - 130)		
1.2343	X 38 CrMoV 5 1	1.4034	X46Cr13	30 (30 - 40)	50 (30 - 100)		
1.2343	X 38 CrMoV 5 1	1.4034	X46Cr13	20 (20 - 30)	40 (20 - 80)		
1.4016	X 6 Cr 17	1.2316	X36 CrMo 16	50 (50 - 60)	90 (50 - 160)		
1.4112	X90CrMoV18	1.2316	X36 CrMo 16	50 (40 - 60)	70 (40 - 140)		
1.4301	X 5 CrNi 18 10	1.4571	X2CrNiMo17-12-2	60 (50 - 70)	90 (50 - 180)		
1.4841	X15CrNiSi25-21	1.4539	X1NiCrMoCu25-20-5	50 (40 - 60)	70 (40 - 140)		
1.4462	X2CrNiMoN22-5-3	1.4501	X2CrNiMoCuWN25-7-4	40 (30 - 50)	60 (30 - 110)		
0.6010	GG-10	0.6025	GG-25	80 (70 - 90)	120 (70 - 230)		
0.6030	GG-30	0.6045	GG-45	60 (50 - 70)	90 (50 - 160)		
0.7040	GGG-40	0.7060	GGG-60	50 (50 - 60)	80 (50 - 150)		
0.7070	GGG-70	0.7080	GGG-80	40 (40 - 50)	70 (40 - 130)		
0.8035	GTW-35-04	0.8045	GTW-45	80 (70 - 90)	120 (70 - 230)		
0.8165	GTS-65-02	0.8170	GTS-70-02	70 (60 - 80)	100 (60 - 190)		
3.0255	Al99,5	3.3315	AlMg 1	100 (90 - 110)	160 (90 - 290)		
3.1355	AlCuMg2	3.2315	AlMgSi1	90 (80 - 110)	140 (80 - 270)		
3.2581	G-AlSi12	3.2163	G-AlSi9Cu3	80 (70 - 90)	120 (70 - 230)		
3.2134	G-AlSi5Cu1Mg	3.2373	G-AlSi9Mg	70 (60 - 80)	110 (60 - 200)		
-	G-AlSi17Cu4Mg (Silafont-90)	-	G-AlSi18CuNiMg (Silafont-92)	40 (40 - 50)	70 (40 - 120)		
2.0380	CuZn39Pb2 (Ms58)	2.0410	CuZn44Pb2	70 (60 - 80)	110 (60 - 210)		
2.0331	CuZn15	2.4070	CuZn28Sn1As	60 (50 - 70)	90 (50 - 170)		
2.0060	E-Cu57	2.0590	CuZn40Fe	50 (50 - 60)	80 (50 - 150)		
3.5612	MgAl6Zn	3.5312	MgAl3Zn	50 (50 - 60)	80 (50 - 150)		
1.4864	X12NiCrSi 36-16	1.4865	G-X40NiCrSi38-18	30 (30 - 40)	50 (30 - 100)		
1.4980	X6NiCrTiMoVB25-15-2	1.4876	X10NiCrAlTi32-20	20 (20 - 30)	40 (20 - 70)		
2.4631	NiCr20TiAl (Nimonic 80A)	2.4856	NiCr22Mo9Nb (Inconel 625)	30 (30 - 40)	50 (30 - 100)		
2.4668	NiCr19Nb5Mo3 (Inconel 718)	2.4955	NiFe25Cr20NbTi	20 (20 - 30)	40 (20 - 80)		
2.4765	CoCr20W15Ni	1.3401	G-X120Mn12	20 (20 - 30)	30 (20 - 60)		
3.7025	Ti99,8	3.7035	Ti99,7	30 (30 - 40)	50 (30 - 100)		
3.7164	TiAl6V4	Ti-6246	Ti-6Al-2Sn-4Zr-6Mo	20 (20 - 30)	30 (20 - 60)		
Ti5553	Ti-5Al-5V-5Mo-3Cr	Ti-1023	Ti-10V-2Fe-3Al	20 (20 - 20)	30 (20 - 50)		
					50 (30 - 90)		
					30 (20 - 60)		
				90 (80 - 110)	140 (80 - 260)		
				100 (90 - 120)	160 (90 - 290)		
				80 (70 - 100)	130 (70 - 240)		
				60 (50 - 70)	90 (50 - 180)		
				90 (80 - 110)	150 (80 - 280)		



Richtige Schnittgeschwindigkeit ist in Abhängigkeit von Dimension und Anwendungssituation zu wählen.

The correct cutting speed must be selected depending on the dimension and application situation.

20 (10 - 50) bevorzugte Wahl / best choice
20 (10 - 50) bedingt möglich / conditionally possible

20 (10 - 50)
empfohlener Startwert (recommended starting value) (bevorzugter Einsatzbereich) (preferred application area)

weitere Informationen zu Vorschub und Schnitttiefe:
• siehe Technische Hinweise:
Allgemeine Informationen über Schnitttiefe und Vorschub Typ DT

more informations about feed and cutting depth:
• look at the technical instructions:
General instructions about cutting depth and feed type DT



TYP DT

Multifunktionswerkzeug zum Bohren und Ausdrehen

Multifunctional tool drilling and boring

Technische Hinweise

Schnittdatenempfehlung:

Technical instructions, speed and feed recommendation: imperial

cutting speed (SFM): V_c (feet/min)
feed: f (inch/rev)

Typ DT

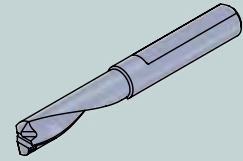

Werkstoffgruppe material group		Zusammensetzung composition		(Zug-)Festigkeit tensile strength	
ISO	Beschreibung / description	Gefüge / structure	Wärmebehandlung / heat treatment	Psi / N/mm ² (Rm) / HB / HRC	
P	Unlegierter Stahl unalloyed steel	ca.lapp. 0,15 % C	geglüht / annealed	61000 Psi / 420 N/mm ² / 125 HB	
		ca.lapp. 0,45 % C	geglüht / annealed	93000 Psi / 640 N/mm ² / 190 HB	
			vergütet / tempered	122000 Psi / 840 N/mm ² / 250 HB	
		ca.lapp. 0,75 % C	geglüht / annealed	132000 Psi / 910 N/mm ² / 270 HB	
			vergütet / tempered	146500 Psi / 1010 N/mm ² / 300 HB	
	Niedriglegierter Stahl low alloyed steel			geglüht / annealed	88500 Psi / 610 N/mm ² / 180 HB
				vergütet / tempered	135000 Psi / 930 N/mm ² / 275 HB
				vergütet / tempered	146500 Psi / 1010 N/mm ² / 300 HB
				vergütet / tempered	174000 Psi / 1200 N/mm ² / 375 HB
				geglüht / annealed	99000 Psi / 680 N/mm ² / 200 HB
Hochlegierter (Werkzeug-)Stahl highly alloyed steel			gehärtet & angelassen / hardened & tempered	160000 Psi / 1100 N/mm ² / 300 HB	
			gehärtet & angelassen / hardened & tempered	189000 Psi / 1300 N/mm ² / 400 HB	
Nichtrostender Stahl stainless steel		ferritisch, martensitisch / ferritic, martensitic	geglüht / annealed	99000 Psi / 680 N/mm ² / 200 HB	
		martensitisch / martensitic	vergütet / tempered	117500 Psi / 810 N/mm ² / 250 HB	
M	Nichtrostender Stahl stainless steel	austenitisch / austenitic	abgeschreckt / quenched	88500 Psi / 610 N/mm ² / 200 HB	
		austenitisch / austenitic	vergütet / tempered	300 HB	
		austenitisch, ferritisch / ferritic, martensitic (Duplex)		113000 Psi / 780 N/mm ² / 230 HB	
K	Grauguss cast iron	perlitisches, ferritisch / pearlitic, ferritic		51000 Psi / 350 N/mm ² / 180 HB	
		perlitisches (martensitisch) / pearlitic (martensitic)		72500 Psi / 500 N/mm ² / 260 HB	
	Gusseisen mit Kugelgraphit cast iron with nodular graphite	ferritisch / ferritic		72500 Psi / 500 N/mm ² / 160 HB	
		perlitisches / pearlitic		122500 Psi / 845 N/mm ² / 250 HB	
Temperguss malleable iron	ferritisch / ferritic		63800 Psi / 440 N/mm ² / 130 HB		
	perlitisches / pearlitic		113000 Psi / 780 N/mm ² / 230 HB		
N	Aluminium - Knetlegierungen wrought aluminum alloys	nicht aushärtbar / uncurable		60 HB	
		aushärtbar / curable	ausgehärtet / cured	49000 Psi / 340 N/mm ² / 100 HB	
	Aluminium - Gusslegierungen cast aluminum alloys	≤ 12% Si, nicht aushärtbar / uncurable		36250 Psi / 250 N/mm ² / 75 HB	
		≤ 12% Si, aushärtbar / curable	ausgehärtet / cured	43500 Psi / 300 N/mm ² / 90 HB	
		> 12% Si, nicht aushärtbar / uncurable		63800 Psi / 440 N/mm ² / 130 HB	
Kupfer und Kupferlegierungen (Bronze / Messing) copper and copper alloys (bronze / brass)	PB > 1 %, Automatenlegierungen / free cutting alloys		54500 Psi / 375 N/mm ² / 110 HB		
	CuZn, CuSnZn		43500 Psi / 300 N/mm ² / 90 HB		
	CuSn, bleifrei & Elektrolitisch / lead free & electrolytic		49000 Psi / 340 N/mm ² / 100 HB		
Magnesium &-Legierungen / Mg-alloys	Magnesium und -Legierungen / and -alloys		70 HB		
S	Warmfeste Legierungen heat-resistant alloys	Fe-Basis / Fe base	geglüht / annealed	99000 Psi / 680 N/mm ² / 200 HB	
			ausgehärtet / cured	137750 Psi / 950 N/mm ² / 280 HB	
		Ni- oder Co-Basis / Ni- or Co-Base	geglüht / annealed	122000 Psi / 840 N/mm ² / 250 HB	
			ausgehärtet / cured	171000 Psi / 1180 N/mm ² / 350 HB	
			gegossen / cast	156600 Psi / 1080 N/mm ² / 320 HB	
	Titanlegierungen titanium alloys	Reintitan / pure titanium		58000 Psi / 400 N/mm ²	
	Alpha- + Beta-Legierungen / -alloys	ausgehärtet / cured	152250 Psi / 1050 N/mm ²		
	Beta-Legierungen / -alloys		203000 Psi / 1400 N/mm ² / 410 HB		
H	Gehärteter Stahl hardened steel		gehärtet & angelassen / hardened & tempered	46-55 HRC	
			gehärtet & angelassen / hardened & tempered	56-60 HRC	
			gehärtet & angelassen / hardened & tempered	61-65 HRC	
			gehärtet & angelassen / hardened & tempered	66-70 HRC	
	Hartguss / chilled cast iron		gegossen / cast	400 HB	
Gehärtetes Guss / hardened cast iron		gehärtet & angelassen / hardened & tempered	55 HRC		
O	Nichtmetallische Werkstoffe non-metallic materials	Kunststoffe, duroplastisch / plastics, duroplastic		≤ 21750 Psi / ≤ 150 N/mm ²	
		Kunststoffe, thermoplastisch / plastics, thermoplastic		≤ 14500 Psi / ≤ 100 N/mm ²	
		aramidfaserverstärkt / aramid fiber reinforced		≤ 145000 Psi / ≤ 1000 N/mm ²	
		glas/kohlefaserverstärkt / glas/carbon fiber reinforced		≤ 145000 Psi / ≤ 1000 N/mm ²	
		Graphit / graphite			

The correct cutting speed must be selected depending on the dimension and application situation.

20 (10 - 50) best choice
20 (10 - 50) conditionally possible

20 (10 - 50) recommended starting value (preferred application area)

more informations about feed and cutting depth:
• look at the technical instructions:
General instructions about cutting depth and feed type DT

TYP DT MAX

Multifunktionswerkzeug zum Bohren und Ausdrehen

Multifunctional tool drilling and boring

Technische Hinweise

Schnittdatenempfehlung: metrisch

Schnittgeschwindigkeit: V_c (m/min)
Vorschub: f (mm/U)

Technical instructions, speed and feed recommendation: metric

cutting speed: V_c (m/min)
feed: f (mm/rev)

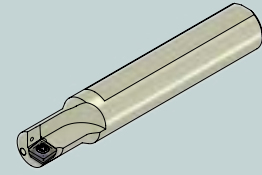

Typ DT MAX



Werkstoffgruppe material group		Zusammensetzung composition		(Zug-)Festigkeit tensile strength	
ISO	Beschreibung / description	Gefüge / structure	Wärmebehandlung / heat treatment	Psi / N/mm ² (Rm) / HB / HRC	
P	Unlegierter Stahl unalloyed steel	ca.lapp. 0,15 % C	geglüht / annealed	61000 Psi / 420 N/mm ² / 125 HB	
		ca.lapp. 0,45 % C	geglüht / annealed	93000 Psi / 640 N/mm ² / 190 HB	
			vergütet / tempered	122000 Psi / 840 N/mm ² / 250 HB	
		ca.lapp. 0,75 % C	geglüht / annealed	132000 Psi / 910 N/mm ² / 270 HB	
			vergütet / tempered	146500 Psi / 1010 N/mm ² / 300 HB	
	Niedriglegierter Stahl low alloyed steel			geglüht / annealed	88500 Psi / 610 N/mm ² / 180 HB
				vergütet / tempered	135000 Psi / 930 N/mm ² / 275 HB
				vergütet / tempered	146500 Psi / 1010 N/mm ² / 300 HB
				vergütet / tempered	174000 Psi / 1200 N/mm ² / 375 HB
	Hochlegierter (Werkzeug)-Stahl highly alloyed steel			geglüht / annealed	99000 Psi / 680 N/mm ² / 200 HB
			gehärtet & angelassen / hardened & tempered	160000 Psi / 1100 N/mm ² / 300 HB	
Nichtrostender Stahl stainless steel			gehärtet & angelassen / hardened & tempered	189000 Psi / 1300 N/mm ² / 400 HB	
		ferritisch, martensitisch / ferritic, martensitic	geglüht / annealed	99000 Psi / 680 N/mm ² / 200 HB	
M	Nichtrostender Stahl stainless steel		vergütet / tempered	117500 Psi / 810 N/mm ² / 250 HB	
			abgeschreckt / quenched	88500 Psi / 610 N/mm ² / 200 HB	
			vergütet / tempered	300 HB	
			austenitisch, ferritisch / ferritic, martensitic (Duplex)		113000 Psi / 780 N/mm ² / 230 HB
K	Grauguss cast iron		perlitisch, ferritisch / pearlitic, ferritic	51000 Psi / 350 N/mm ² / 180 HB	
			perlitisch (martensitisch) / pearlitic (martensitic)	72500 Psi / 500 N/mm ² / 260 HB	
	Gusseisen mit Kugelgraphit cast iron with nodular graphite		ferritisch / ferritic	72500 Psi / 500 N/mm ² / 160 HB	
			perlitisch / pearlitic	122500 Psi / 845 N/mm ² / 250 HB	
	Temperguss malleable iron		ferritisch / ferritic	63800 Psi / 440 N/mm ² / 130 HB	
		perlitisch / pearlitic	113000 Psi / 780 N/mm ² / 230 HB		
N	Aluminium - Knetlegierungen wrought aluminum alloys		nicht aushärtbar / uncurable	60 HB	
			aushärtbar / curable	ausgehärtet / cured	49000 Psi / 340 N/mm ² / 100 HB
	Aluminium - Gusslegierungen cast aluminum alloys		≤ 12% Si, nicht aushärtbar / uncurable		36250 Psi / 250 N/mm ² / 75 HB
			≤ 12% Si, aushärtbar / curable	ausgehärtet / cured	43500 Psi / 300 N/mm ² / 90 HB
			> 12% Si, nicht aushärtbar / uncurable		63800 Psi / 440 N/mm ² / 130 HB
	Kupfer und Kupferlegierungen (Bronze / Messing) copper and copper alloys (bronze / brass)		PB > 1 %, Automatenlegierungen / free cutting alloys		54500 Psi / 375 N/mm ² / 110 HB
		CuZn, CuSnZn		43500 Psi / 300 N/mm ² / 90 HB	
		CuSn, bleifrei & Elektrolitisch / lead free & electrolytic		49000 Psi / 340 N/mm ² / 100 HB	
	Magnesium &-Legierungen / Mg-alloys	Magnesium und -Legierungen / and -alloys		70 HB	
S	Warmfeste Legierungen heat-resistant alloys		Fe-Basis / Fe base	geglüht / annealed	99000 Psi / 680 N/mm ² / 200 HB
				ausgehärtet / cured	137750 Psi / 950 N/mm ² / 280 HB
			Ni- oder Co-Basis / Ni- or Co-Base	geglüht / annealed	122000 Psi / 840 N/mm ² / 250 HB
				ausgehärtet / cured	171000 Psi / 1180 N/mm ² / 350 HB
				gegossen / cast	156600 Psi / 1080 N/mm ² / 320 HB
	Titanlegierungen titanium alloys		Reintitan / pure titanium		58000 Psi / 400 N/mm ²
			Alpha- + Beta-Legierungen / -alloys	ausgehärtet / cured	152250 Psi / 1050 N/mm ²
		Beta-Legierungen / -alloys		203000 Psi / 1400 N/mm ² / 410 HB	
H	Gehärteter Stahl hardened steel		gehärtet & angelassen / hardened & tempered	46-55 HRC	
			gehärtet & angelassen / hardened & tempered	56-60 HRC	
			gehärtet & angelassen / hardened & tempered	61-65 HRC	
			gehärtet & angelassen / hardened & tempered	66-70 HRC	
	Hartguss / chilled cast iron		gegossen / cast	400 HB	
Gehärtetes Guss / hardened cast iron		gehärtet & angelassen / hardened & tempered	55 HRC		
O	Nichtmetallische Werkstoffe non-metallic materials		Kunststoffe, duroplastisch / plastics, duroplastic	≤ 21750 Psi / ≤ 150 N/mm ²	
			Kunststoffe, thermoplastisch / plastics, thermoplastic	≤ 14500 Psi / ≤ 100 N/mm ²	
			aramidfaserverstärkt / aramid fiber reinforced	≤ 145000 Psi / ≤ 1000 N/mm ²	
			glas/kohlefaserverstärkt / glas/carbon fiber reinforced	≤ 145000 Psi / ≤ 1000 N/mm ²	
			Graphit / graphite		

Richtige Schnittgeschwindigkeit ist in Abhängigkeit von Dimension und Anwendungssituation zu wählen.

The correct cutting speed must be selected depending on the dimension and application situation.

20 (10 - 50) bevorzugte Wahl / best choice
20 (10 - 50) bedingt möglich / conditionally possible

20 (10 - 50)
empfohlener Startwert
recommended starting value
(bevorzugter Einsatzbereich)
(preferred application area)

weitere Informationen zu Vorschub und Schnitttiefe:
• siehe Technische Hinweise:
Allgemeine Informationen über Schnitttiefe und Vorschub Typ DT MAX

more informations about feed and cutting depth:
• look at the technical instructions:
General instructions about cutting depth and feed type DT MAX



TYP DT MAX

Multifunktionswerkzeug zum Bohren und Ausdrehen

Multifunctional tool drilling and boring

Technische Hinweise

Schnittdatenempfehlung:

Technical instructions, speed and feed recommendation: imperial

cutting speed (SFM): V_c (feet/min)
feed: f (inch/rev)

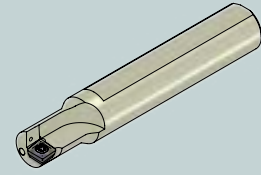

Typ DT MAX



Werkstoffgruppe material group		Zusammensetzung composition		(Zug-)Festigkeit tensile strength	
ISO	Beschreibung / description	Gefüge / structure	Wärmebehandlung / heat treatment	Psi / N/mm ² (Rm) / HB / HRC	
P	Unlegierter Stahl unalloyed steel	ca.lapp. 0,15 % C	geglüht / annealed	61000 Psi / 420 N/mm ² / 125 HB	
		ca.lapp. 0,45 % C	geglüht / annealed	93000 Psi / 640 N/mm ² / 190 HB	
			vergütet / tempered	122000 Psi / 840 N/mm ² / 250 HB	
		ca.lapp. 0,75 % C	geglüht / annealed	132000 Psi / 910 N/mm ² / 270 HB	
			vergütet / tempered	146500 Psi / 1010 N/mm ² / 300 HB	
	Niedriglegierter Stahl low alloyed steel			geglüht / annealed	88500 Psi / 610 N/mm ² / 180 HB
				vergütet / tempered	135000 Psi / 930 N/mm ² / 275 HB
				vergütet / tempered	146500 Psi / 1010 N/mm ² / 300 HB
				vergütet / tempered	174000 Psi / 1200 N/mm ² / 375 HB
	Hochlegierter (Werkzeug-)Stahl highly alloyed steel			geglüht / annealed	99000 Psi / 680 N/mm ² / 200 HB
			gehärtet & angelassen / hardened & tempered	160000 Psi / 1100 N/mm ² / 300 HB	
Nichtrostender Stahl stainless steel			gehärtet & angelassen / hardened & tempered	189000 Psi / 1300 N/mm ² / 400 HB	
		ferritisch, martensitisch / ferritic, martensitic	geglüht / annealed	99000 Psi / 680 N/mm ² / 200 HB	
M	Nichtrostender Stahl stainless steel	martensitisch / martensitic	vergütet / tempered	117500 Psi / 810 N/mm ² / 250 HB	
		austenitisch / austenitic	abgeschreckt / quenched	88500 Psi / 610 N/mm ² / 200 HB	
		austenitisch / austenitic	vergütet / tempered	300 HB	
K	Grauguss cast iron	austenitisch, ferritisch / ferritic, martensitic (Duplex)		113000 Psi / 780 N/mm ² / 230 HB	
		perlitisches, ferritisch / pearlitic, ferritic		51000 Psi / 350 N/mm ² / 180 HB	
	Gusseisen mit Kugelgraphit cast iron with nodular graphite	perlitisches (martensitisch) / pearlitic (martensitic)		72500 Psi / 500 N/mm ² / 260 HB	
		ferritisch / ferritic		72500 Psi / 500 N/mm ² / 160 HB	
Temperguss malleable iron	perlitisches / pearlitic		122500 Psi / 845 N/mm ² / 250 HB		
	ferritisch / ferritic		63800 Psi / 440 N/mm ² / 130 HB		
N	Aluminium - Knetlegierungen wrought aluminum alloys	Magnesium und -Legierungen / and -alloys		113000 Psi / 780 N/mm ² / 230 HB	
		nicht aushärtbar / uncurable		60 HB	
	Aluminium - Gusslegierungen cast aluminum alloys	aushärtbar / curable	ausgehärtet / cured	49000 Psi / 340 N/mm ² / 100 HB	
		≤ 12% Si, nicht aushärtbar / uncurable		36250 Psi / 250 N/mm ² / 75 HB	
		≤ 12% Si, aushärtbar / curable	ausgehärtet / cured	43500 Psi / 300 N/mm ² / 90 HB	
	Kupfer und Kupferlegierungen (Bronze / Messing) copper and copper alloys (bronze / brass)	> 12% Si, nicht aushärtbar / uncurable		63800 Psi / 440 N/mm ² / 130 HB	
PB > 1 %, Automatenlegierungen / free cutting alloys			54500 Psi / 375 N/mm ² / 110 HB		
Magnesium &-Legierungen / Mg-alloys	CuZn, CuSnZn		43500 Psi / 300 N/mm ² / 90 HB		
	CuSn, bleifrei & Elektrolitisch / lead free & electrolytic		49000 Psi / 340 N/mm ² / 100 HB		
S	Warmfeste Legierungen heat-resistant alloys	Fe-Basis / Fe base	geglüht / annealed	99000 Psi / 680 N/mm ² / 200 HB	
			ausgehärtet / cured	137750 Psi / 950 N/mm ² / 280 HB	
		Ni- oder Co-Basis / Ni- or Co-Base	geglüht / annealed	122000 Psi / 840 N/mm ² / 250 HB	
			ausgehärtet / cured	171000 Psi / 1180 N/mm ² / 350 HB	
	Titanlegierungen titanium alloys	gegossen / cast		156600 Psi / 1080 N/mm ² / 320 HB	
		Reintitan / pure titanium		58000 Psi / 400 N/mm ²	
		Alpha- + Beta-Legierungen / -alloys	ausgehärtet / cured	152250 Psi / 1050 N/mm ²	
H	Gehärteter Stahl hardened steel	Beta-Legierungen / -alloys		203000 Psi / 1400 N/mm ² / 410 HB	
			gehärtet & angelassen / hardened & tempered	46-55 HRC	
			gehärtet & angelassen / hardened & tempered	56-60 HRC	
			gehärtet & angelassen / hardened & tempered	61-65 HRC	
	Hartguss / chilled cast iron		gehärtet & angelassen / hardened & tempered	66-70 HRC	
Gehärtetes Guss / hardened cast iron		gegossen / cast	400 HB		
O	Nichtmetallische Werkstoffe non-metallic materials		gehärtet & angelassen / hardened & tempered	55 HRC	
		Kunststoffe, duroplastisch / plastics, duroplastic		≤ 21750 Psi / ≤ 150 N/mm ²	
		Kunststoffe, thermoplastisch / plastics, thermoplastic		≤ 14500 Psi / ≤ 100 N/mm ²	
		aramidfaserverstärkt / aramid fiber reinforced		≤ 145000 Psi / ≤ 1000 N/mm ²	
		glas/kohlefaserverstärkt / glas/carbon fiber reinforced		≤ 145000 Psi / ≤ 1000 N/mm ²	
Graphit / graphite					

20 (10 - 50) best choice
20 (10 - 50) conditionally possible

The correct cutting speed must be selected depending on the dimension and application situation.

20 (10 - 50)
recommended starting value (preferred application area)

more informations about feed and cutting depth:
• look at the technical instructions:
General instructions about cutting depth and feed type DT MAX



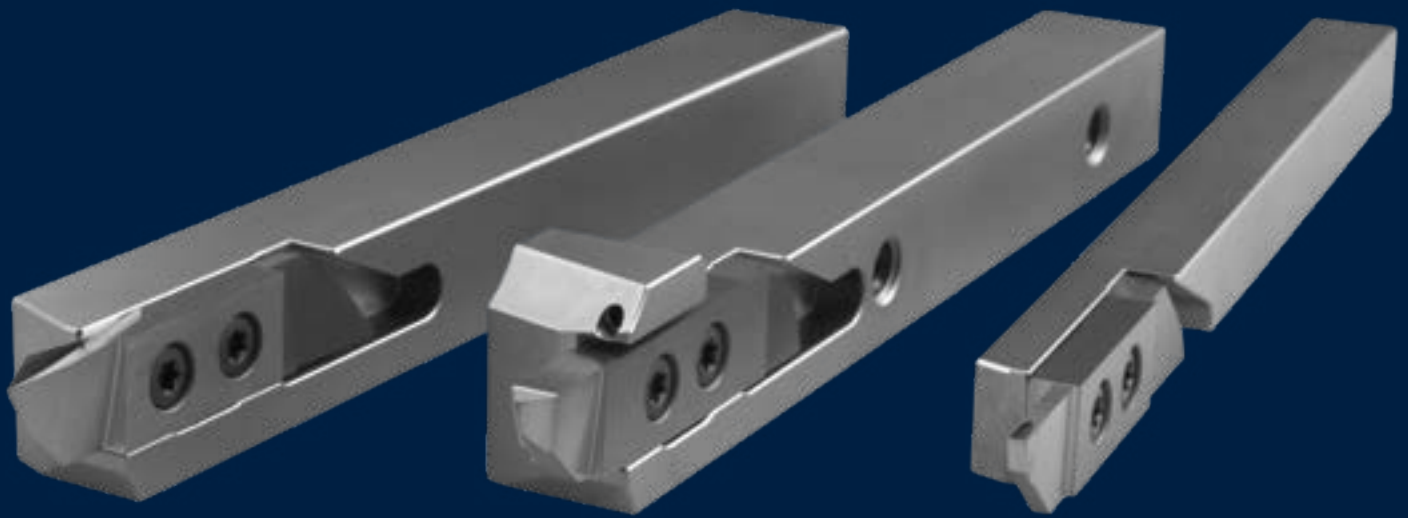

SWISSLINE

$b \geq 0.5 \text{ mm}$

SWISSLINE

Miniatúraußenbearbeitung,
zweischneidig

miniature external machining,
two-cutting edges

Übersicht

summary

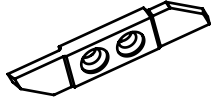

Allgemeine Beschreibung

general instructions

... 6

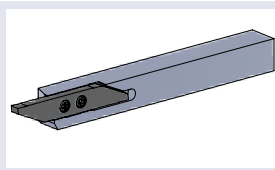

Klemmhalter

toolholder

**Maße
dimensions
[mm]**

**Seite
page**

Typ HW10

Klemmhalter

toolholder

... 7

Typ HW15

Klemmhalter
mit Innenkühlung

toolholder
with internal cooling

... 8

Typ HW20

Klemmhalter,
abgesetzte Version

toolholder,
offset version

... 9



**Schneidplattenhalter
für Rückseitenbearbeitung
auf Langdrehautomaten**

**toolholder
for rear end machining
on Swiss type lathes**

**Maße
dimensions
[mm]**

**Seite
page**

Typ UMHV

Schneidplattenhalter

toolholder

... 10

SWISSLINE

Miniatúraußenbearbeitung,
zweischneidig

miniature external machining,
two-cutting edges

Übersicht

summary

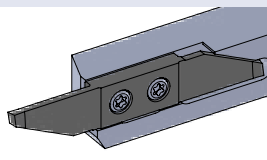

Wendeschneidplatten
Abstechen

indexable inserts
parting off

Maße
dimensions
[mm]

Seite
page

Typ ZW10	Abstechen	parting off	t max. = 6 - 16 b = 0.8 - 3	... 11
Typ ZW11	Abstechen, Schneide versetzt	parting off, offset cutting edge	t max. = 6 - 16 b = 0.8 - 3	... 12
Typ ZW12	Abstechen mit Gegenspindel	parting off with counter spindle	t max. = 6 b = 0.8 / 1.2	... 13
Typ ZW13	Abstechen mit Gegenspindel, Schneide versetzt	parting off with counter spindle, offset cutting edge	t max. = 6 b = 0.8 / 1.2	... 14
Typ ZW14	Abstechen, mit Spanformer	parting off, with chip former	t max. = 8 - 16 b = 1.5 - 3	... 15
Typ ZW15	Abstechen, Schneide versetzt, mit Spanformer	parting off, offset cutting edge, with chip former	t max. = 8 - 16 b = 1.5 - 3	... 16
Typ ZW16	Abstechen, mit Spantreppe	parting off, with chip breaker	t max. = 8 - 16 b = 1.5 - 3	... 17
Typ ZW17	Abstechen, Schneide versetzt, mit Spantreppe	parting off, offset cutting edge, with chip breaker	t max. = 8 - 16 b = 1.5 - 3	... 18
Typ ZW18	Abstechen unter 0°, mit Spanformer	parting off with 0°, with chipformer	t max. = 10 - 16 b = 1.5 - 3	... 19
Typ ZW19	Abstechen unter 0°, mit Spantreppe	parting off with 0°, with chip breaker	t max. = 10 - 16 b = 1.5 - 3	... 20
Typ ZW1A	Abstechen, mit gesintertem Spanformer	parting off, with sintered chipformer	t max. = 10 b = 2	... 21
Typ ZW1B	Abstechen, Schneide versetzt, mit gesintertem Spanformer	parting off, offset cutting edge, with sintered chipformer	t max. = 10 b = 2	... 22
Typ ZW1C	Abstechen unter 0°, mit gesintertem Spanformer	parting off with 0°, with sintered chip former	t max. = 10 b = 2	... 23



SWISSLINE

Miniatúraußenbearbeitung,
zweischneidig

miniature external machining,
two-cutting edges

Übersicht

summary

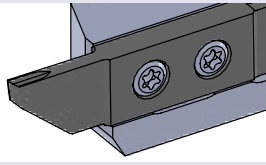

Wendeschneidplatten Drehen und Abstechen

indexable inserts turning and parting off

Maße dimensions [mm]

Seite page

Typ ZW20	Drehen und Abstechen, Wipergeometrie	turning and parting off, wiper geometry	t max. = 10 b = 2	... 24
Typ ZW21	Drehen und Abstechen, Schneide versetzt, Wipergeometrie	turning and parting off, offset cutting edge, wiper geometry	t max. = 10 b = 2	... 25
Typ ZW22	Drehen und Abstechen, mit Spanformer, Wipergeometrie	turning and parting off, with chipformer, wiper geometry	t max. = 10 b = 2	... 26
Typ ZW23	Drehen und Abstechen, Schneide versetzt, mit Spanformer, Wipergeometrie	turning and parting off, offset cutting edge, with chipformer, wiper geometry	t max. = 10 b = 2	... 27

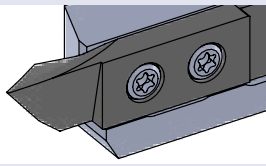

Wendeschneidplatten Drehen

indexable inserts turning

Maße dimensions [mm]

Seite page

Typ ZW30	Vornedrehen	turning in front	t max. = 8 b = 3.4	... 28
Typ ZW31	Vornedrehen, mit Spanformer, Wipergeometrie	turning in front, with chipformer, wiper geometry	t max. = 8 b = 3.4	... 29
Typ ZW40	Kopierdrehen vorne, Schneide versetzt, mit Spanformer	profiling in front, offset cutting edge, with chipformer	t max. = 11 b = 3.2	... 30
Typ ZW41	Kopierdrehen hinten, mit Spanformer	profiling at the back, with chipformer	t max. = 11 b = 3.2	... 31
Typ ZW50	Hintendrehen, Wipergeometrie	turning at the back, wiper geometry	t max. = 6 - 8 b = 0.8 - 1.8	... 32
Typ ZW51	Kopierdrehen hinten, mit Spanformer, Wipergeometrie	profiling at the back, with chip former, wiper geometry	t max. = 6 b = 0.5	... 33
Typ ZW52	Hintendrehen, mit Spantreppe	turning at the back, with chip breaker	t max. = 4.5 b = 0.8	... 34
Typ ZW60	Einstecken und Längsdrehen	grooving and turning	t max. = 2.5 - 6 b = 1 - 3	... 35
Typ ZW61	Einstecken und Längsdrehen, mit Spantreppe	grooving and turning, with chip breaker	t max. = 2.5 - 6 b = 0.8 - 3	... 36

SWISSLINE

Miniaturaußenbearbeitung,
zweischneidig

miniature external machining,
two-cutting edges

Übersicht

summary

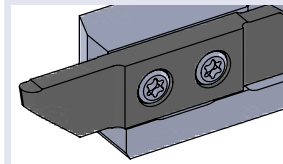

**Wendeschneidplatten
Stechdrehen**

**indexable inserts
grooving**

**Maße
dimensions
[mm]**

**Seite
page**

Typ ZW70

Stechdrehen,
Vollradius mit Spantreppe

grooving,
full radius with chip breaker

t max. = 2 - 16
b = 0.5 - 3.0

... 37

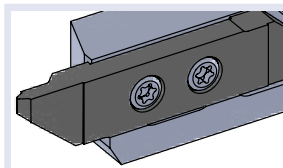

**Wendeschneidplatten
Gewindedrehen**

**indexable inserts
threading**

**Maße
dimensions
[mm]**

**Seite
page**

Typ ZW90

Gewindedrehen,
Vollprofil, 60°

threading,
full profile, 60°

M1 - M4.5
P = 0.25 - 0.75

... 38

Typ ZW90

Gewindedrehen,
Vollprofil, 60°

threading,
full profile, 60°

M5 - M27
P = 0.8 - 3.0

... 39

Typ ZW90

Gewindedrehen,
Whitworth, Vollprofil, 55°

threading,
Whitworth, full profile, 55°

threads / inch
28 - 11
P = 0.907 - 2.309

... 40

Typ ZW94

Gewindedrehen,
Teilprofil, 55° / 60°

threading,
partial profile, 55° / 60°

P = 0.25 - 2.0

... 41

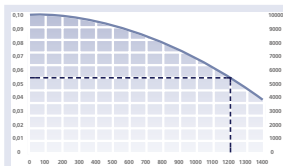

Technische Hinweise

Technical Instructions

**Seite
page**

Beschreibung der
Schneidenausführungen

Description of the cutting types

... 43

Allgemeine Informationen zum
Gewindeschneiden

General informations about threading

... 44

Hartmetallsorten und Beschichtungen

carbide grades and coatings

... 46

Schnittdatenempfehlung

speed and feed recommendation

... 48



SWISSLINE

Miniatúraußenbearbeitung,
zweischneidig

miniature external machining,
two-cutting edges

Allgemeine Beschreibung

general instruction

Swissline

Unser Programm Swissline bietet ein Stech-Drehwerkzeug für Langdrehautomaten mit einem Stangendurchlass von maximal 32 mm. Schneiden für das Abstechen, Stechdrehen, Überdrehen, Kopierdrehen und Gewindeschneiden sind im Standard verfügbar. Ein breites Angebot von geschliffenen Haltern mit veredelter Oberfläche und Schaftquerschnitten von 8 - 25 mm runden das Programm ab.

Swissline

A turn and parting off tool system for Swiss type lathes up to \varnothing 32 mm. Inserts for parting off, grooving, turning, profiling and threading are in standard available. A wide range of refined tool holders and shank sizes between 8 - 25 mm completes our product line.

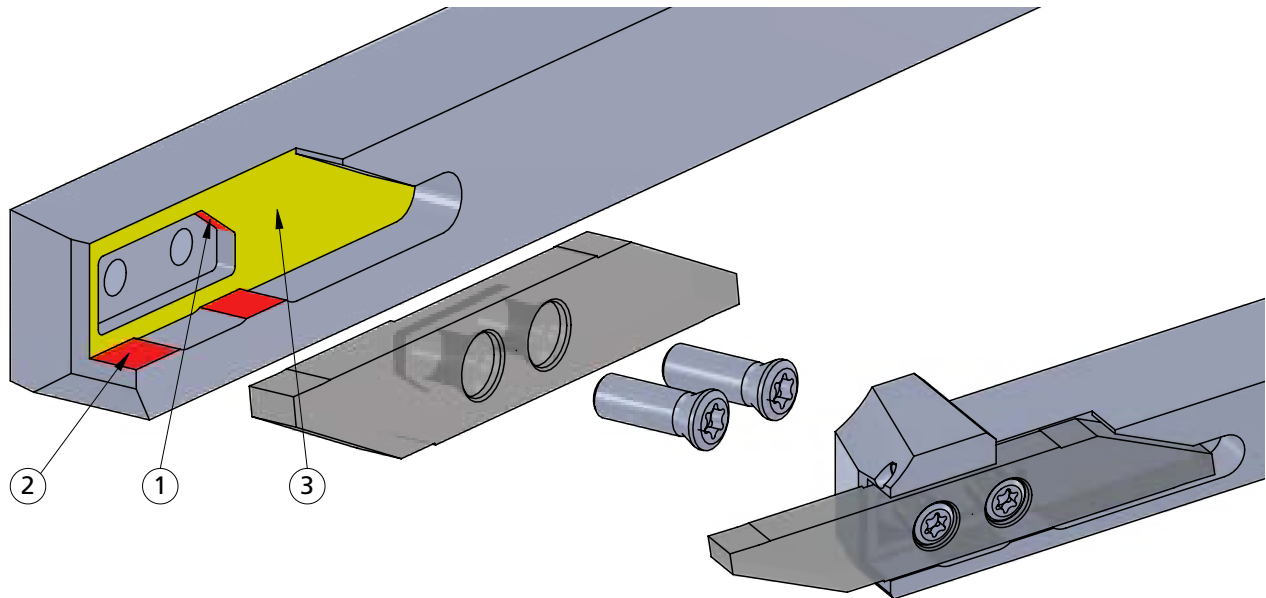

Vorteile:	Advantages:
Große Auswahl an Schneidgeometrien mit speziellen Spanleitstufen für die Bearbeitung	Large selection of insert geometries with different chip breaker geometries
Exakte Positionierung durch 2 Schrauben mit Anschlag (1 + 2) für die axiale Ausrichtung	Special chip breaker design for machining of small- to mid-sized work pieces
Die große Auflagefläche garantiert eine senkrechte Ausrichtung (3)	Perpendicularity guaranteed by two fixing screws, large support face and a genuine stop face for axial positioning
Schnittkräfte werden direkt von der Wendepatte auf den Halter übertragen, sodass keine Abscherkräfte auf die Schrauben wirken	The cutting forces are transferred directly from the insert to the holder; the screws are therefore not exposed to shear stress
Wendeschneidplatten bedingt nachschleifbar	limited regrinding possibility
Bei Schneidenbruch ist die zweite intakte Schneide trotzdem einsetzbar	If first cutting edge has crashed the second is still usable

SWISSLINE

Miniaturaußenbearbeitung,
zweischneidig

miniature external machining,
two-cutting edges

Typ HW10

Klemmhalter

toolholder

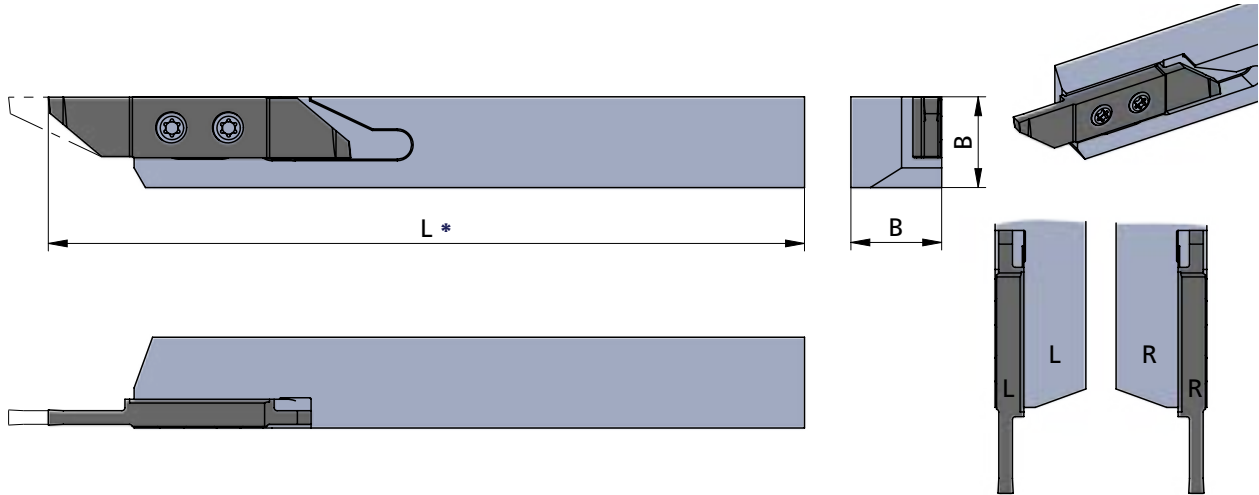

Beispielzeichnung
exemplary application

Rechts (R): wie gezeichnet
Links (L): spiegelbildlich

Rechte Schneidpl. in rechtem Halter
Linke Schneidpl. in linkem Halter

Abmessungen in mm

righthand version (R): as shown
lefthand version (L): mirror image

use RH insert in RH tool holder and
LH insert in LH tool holder

dimensions in mm



Bestellnummer part number	B	B (inch)	L	Spannschraube screw	Schraubenschlüssel wrench	Anzugs- drehmoment torque	für Schneidplatte for insert
R/L HW10.0808080	8		80	A.SPS022	T8F-P	1.2 Nm	R/L ZW...
R/L HW10.0808100	8		100				
R/L HW10.1010080	10		80				
R/L HW10.1010100	10		100				
R/L HW10.1212100	12		100				
R/L HW10.1616125	16		125				
R/L HW10.2020125	20		125				
R/L HW10.2525150	25		150				
R/L HW10.Z0909080	9.53	3/8"	80	A.SPS023	T8F-P	1.2 Nm	R/L ZW...
R/L HW10.Z0909100	9.53	3/8"	100				
R/L HW10.Z1212100	12.7	1/2"	100				
R/L HW10.Z1515125	15.87	5/8"	125				
R/L HW10.Z1919125	19.05	3/4"	125				

* L gemessen mit Schneidplatte
t max. ≤ 10 mm

L measured with insert
t max. ≤ 10 mm

Bestellbeispiel:
für rechte Ausführung
RHW10.0808080

order-example:
righthand version
RHW10.0808080

SWISSLINE

Miniatúraußenbearbeitung,
zweischneidig

miniature external machining,
two-cutting edges

Typ HW15

Klemmhalter
mit Innenkühlung

toolholder
with internal cooling

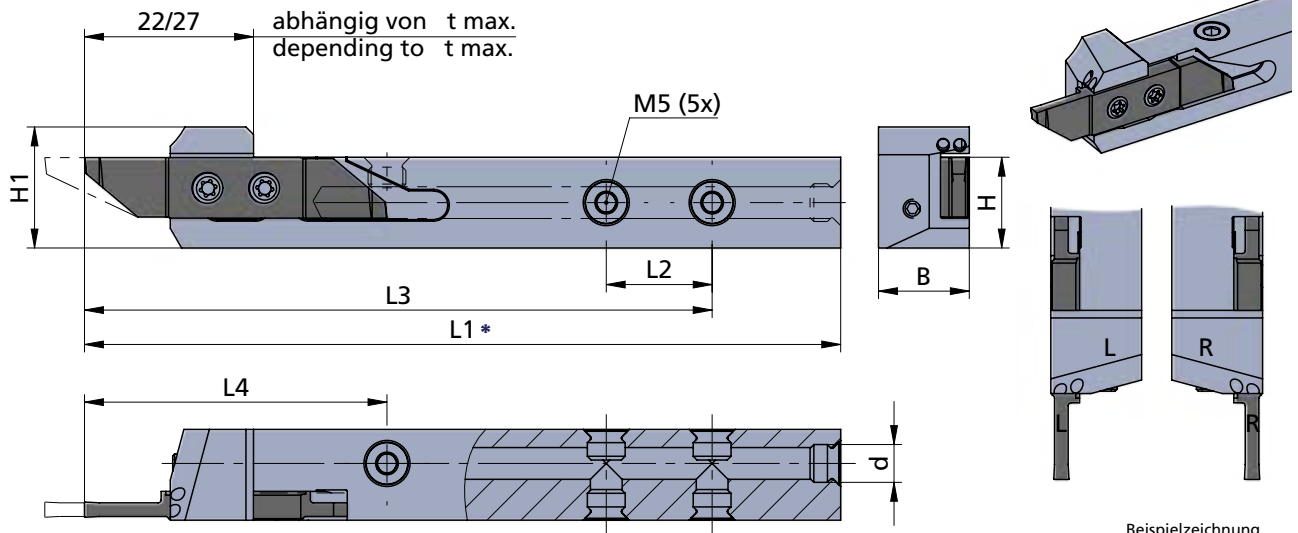

Rechts (R): wie gezeichnet
Links (L): spiegelbildlich

Rechte Schneidpl. in rechtem Halter
Linke Schneidpl. in linkem Halter

Abmessungen in mm

righthand version (R): as shown
lefthand version (L): mirror image

use RH insert in RH tool holder and
LH insert in LH tool holder

dimensions in mm



Bestellnummer part number	B	B (inch)	H	H (inch)	L1	L2	L3	L4	H1	d	Spannschraube screw	Schraubenschlüssel wrench	Anzugs- drehmoment torque	für Schneidplatte for insert
R/L HW15.1208100	12		8		100	14	83	40	12.2	M5	A.SPS023	T8F-P	1.2 Nm	R/L ZW....
R/L HW15.1210100	12		10		100	14	83	40	14	M5				
R/L HW15.1212100	12		12		100	14	83	40	16	M5				
R/L HW15.1616125	16		16		125	14	100	50	20	G1/8"				
R/L HW15.2020125	20		20		125	14	100	50	24	G1/8"				
R/L HW15.2525125	25		25		125	14	100	50	29	G1/8"				
R/L HW15.Z0909100	12.0		9.53	3/8"	100	14	83	40	13.5	M5				
R/L HW15.Z1212100	12.7	1/2"	12.7	1/2"	100	14	83	40	16.7	M5				
R/L HW15.Z1515125	15.87	5/8"	15.87	5/8"	125	14	100	50	19.9	G1/8"				
R/L HW15.Z1919125	19.05	3/4"	19.05	3/4"	125	14	100	50	23	G1/8"				

Lieferumfang:
Halter ohne Kühlmittelanschluss

* L1 gemessen mit Schneidplatte
t max. ≤ 10 mm

L1 measured with insert
t max. ≤ 10 mm

Scope of delivery:
Holder without coolant connector

order-example:
righthand version
RHW15.1208100

Bestellbeispiel:
für rechte Ausführung
RHW15.1208100

SWISSLINE

Miniatúraußenbearbeitung,
zweischneidig

miniature external machining,
two-cutting edges

Typ HW20

Klemhalter,
abgesetzte Version

toolholder,
offset version

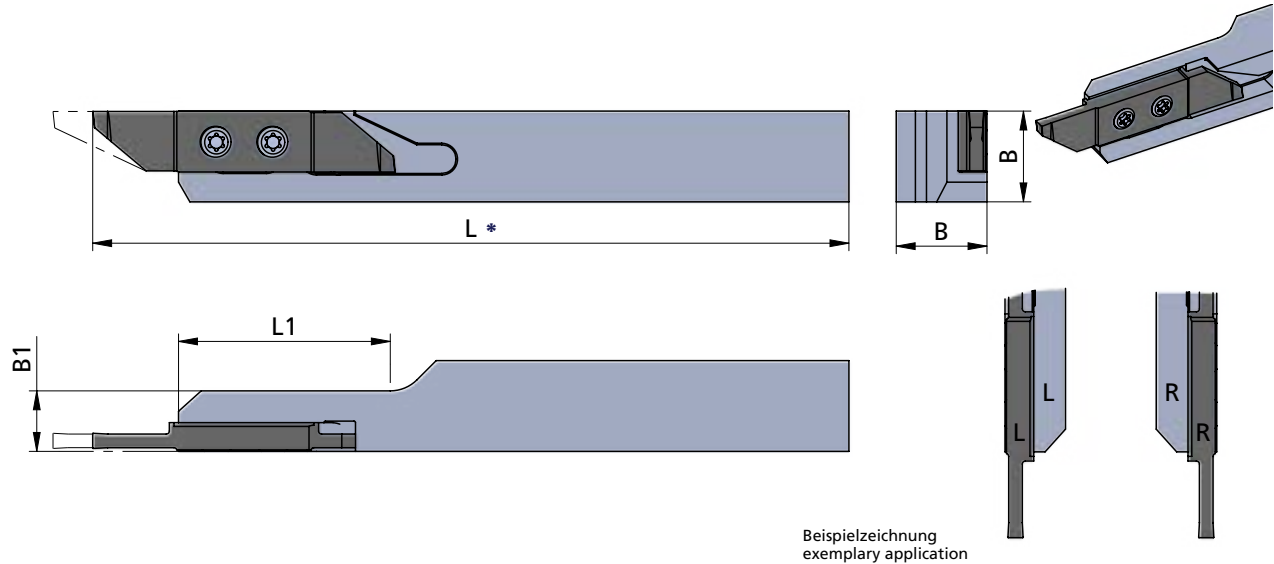

Beispielzeichnung
exemplary application

Rechts (R): wie gezeichnet
Links (L): spiegelbildlich

Rechte Schneidpl. in rechtem Halter
Linke Schneidpl. in linkem Halter

Abmessungen in mm

righthand version (R): as shown
lefthand version (L): mirror image

use RH insert in RH tool holder and
LH insert in LH tool holder

dimensions in mm



Bestellnummer part number	B	B (inch)	L	L1	B1	Spannschraube screw	Schraubenschlüssel wrench	Anzugs- drehmoment torque	für Schneidplatte for insert
R/L HW20.1010080	10		80	28	8	A.SPS022	T8F-P	1.2 Nm	R/L ZW....
R/L HW20.1010100	10		100	28	8				
R/L HW20.1212100	12		100	28	8				
R/L HW20.1616125	16		125	28	8				
R/L HW20.Z0909080	9.53	3/8"	80	28	8				
R/L HW20.Z0909100	9.53	3/8"	100	28	8				
R/L HW20.Z1212100	12.7	1/2"	100	28	8				
R/L HW20.Z1515125	15.87	5/8"	125	28	8				

* L gemessen mit Schneidplatte
t max. ≤ 10 mm

L measured with insert
t max. ≤ 10 mm

Bestellbeispiel:
für rechte Ausführung
RHW20.1010080

order-example:
righthand version
RHW20.1010080

SWISSLINE

Miniatúraußenbearbeitung,
zweischneidig

miniature external machining,
two-cutting edges

Typ UMHV

Schneidplattenhalter
für Rückseitenbearbeitung
auf Langdrehautomaten

toolholder
for rear end machining
on Swiss type lathes

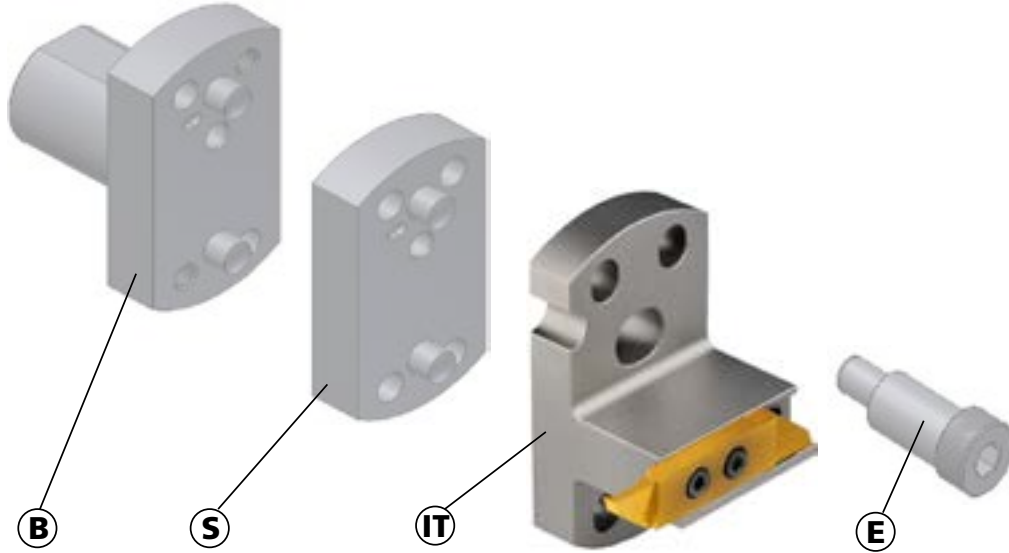

Klemmhalter für rechte und linke
Schneideinsätze einsetzbar

toolholder for right and left
inserts usable

Abmessungen in mm

dimensions in mm



Bestellnummer part number	Position	Bezeichnung description	Schneideinsatz insert
UMHV-I0201SWISSRL	IT	Schneidplattenhalter / toolholder	RL ZW...
auf Anfrage / on request	B	Grundhalter / basic toolholder	
auf Anfrage / on request	S	Zwischenplatte / spacer	
auf Anfrage / on request	E	Excenter / excenter	

SWISSLINE

Miniatúraußenbearbeitung,
zweischneidig

miniature external machining,
two-cutting edges

Typ ZW10

Wendeschneidplatten,
zum Abstechen

indexable inserts
for parting off

Stechtiefe t max. = 6 - 16 mm
Stechbreite b = 0.8 - 3.0 mm

depth of groove t max. = 6 - 16 mm
width of groove b = 0.8 - 3.0 mm

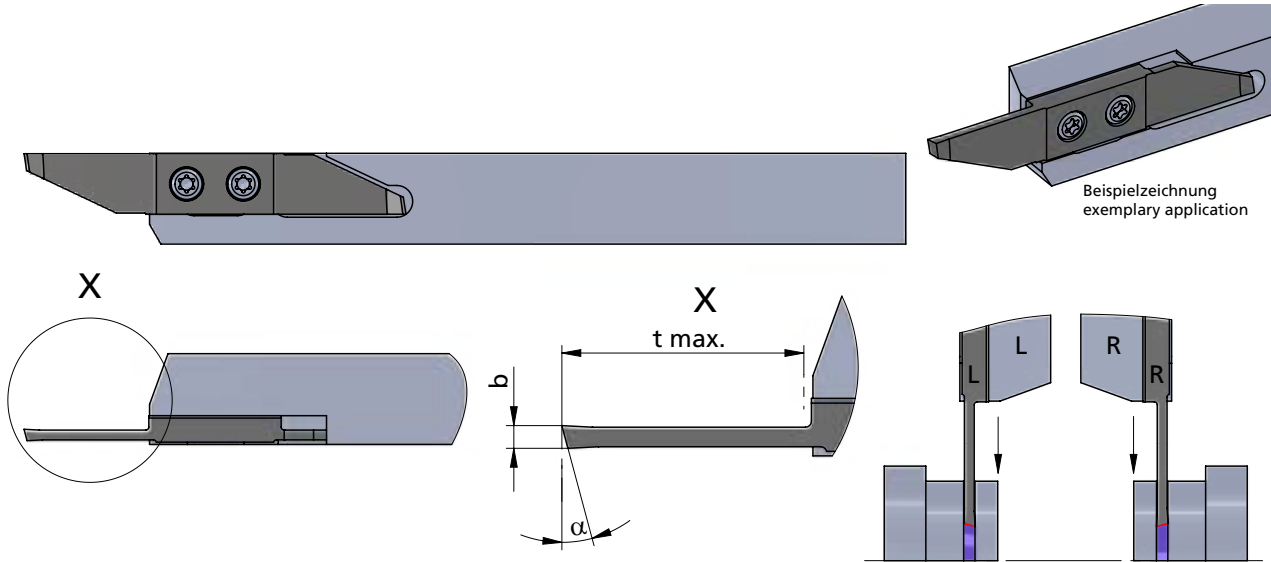

Rechts (R): wie gezeichnet
Links (L): spiegelbildlich

Rechte Schneidpl. in rechtem Halter
Linke Schneidpl. in linkem Halter

Abmessungen in mm

righthand version (R): as shown
lefthand version (L): mirror image

use RH insert in RH tool holder and
LH insert in LH tool holder

dimensions in mm



Bestellnummer part number	b	t max.	α	Klemmhalter Typ toolholder type			
				K10F	CN45F	AL41F	P18C
R/L ZW10.08061500	0.8	6	15°	●			●
R/L ZW10.08101500	0.8	10	15°	●			●
R/L ZW10.10061500	1.0	6	15°	●			●
R/L ZW10.10131500	1.0	13	15°	●			●
R/L ZW10.12061500	1.2	6	15°	●			●
R/L ZW10.15081500	1.5	8	15°	●			●
R/L ZW10.15161500	1.5	16	15°	●			●
R/L ZW10.18081500	1.8	8	15°	●			●
R/L ZW10.20101500	2.0	10	15°	●			●
R/L ZW10.20161500	2.0	16	15°	●			●
R/L ZW10.25131500	2.5	13	15°	●			●
R/L ZW10.25161500	2.5	16	15°	●			●
R/L ZW10.30161500	3.0	16	15°	●			●

Weitere HM Sorten können Sie in der Sortenübersicht im Kapitel "Technische Hinweise" und der Preisliste finden.

Bestellbeispiel:
für rechte Ausführung und Sorte
RZW10.08061500/P18C

More carbide grades you can find in the grades summary in the chapter "technical instructions" and in the price list.

order-example:
righthand version and grade
RZW10.08061500/P18C

SWISSLINE

Miniatúraußenbearbeitung,
zweischneidig

miniature external machining,
two-cutting edges

Typ ZW11

Wendeschneidplatten,
zum Abstechen,
Schneide versetzt

indexable inserts,
for parting off,
offset cutting edge

Stechtiefe t max. = 6 - 16 mm
Stechbreite b = 0.8 - 3.0 mm

depth of groove t max. = 6 - 16 mm
width of groove b = 0.8 - 3.0 mm

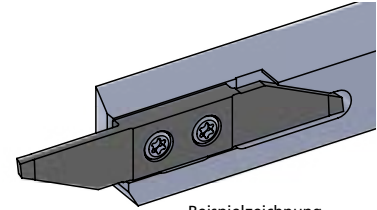
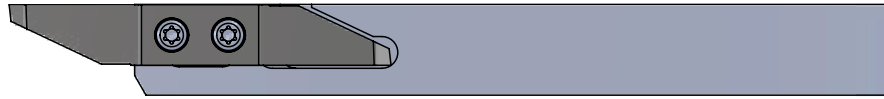

Beispielzeichnung
exemplary application

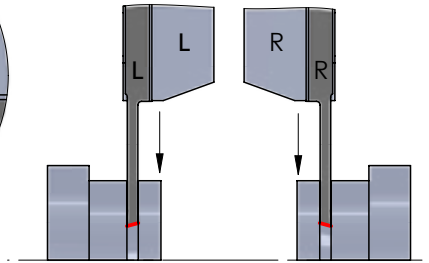
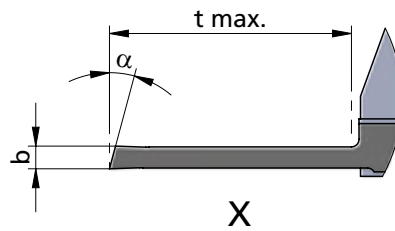
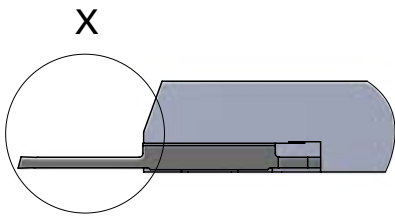

Rechts (R): wie gezeichnet
Links (L): spiegelbildlich

Rechte Schneidpl. in rechtem Halter
Linke Schneidpl. in linkem Halter

Abmessungen in mm

righthand version (R): as shown
lefthand version (L): mirror image

use RH insert in RH tool holder and
LH insert in LH tool holder

dimensions in mm



Bestellnummer part number	b	t max.	α	Klemmhalter Typ toolholder type			
				K10F	CN45F	AL41F	P18C
R/L ZW11.08061500	0.8	6	15°	●			●
R/L ZW11.08101500	0.8	10	15°	●			●
R/L ZW11.10061500	1.0	6	15°	●			●
R/L ZW11.10131500	1.0	13	15°	●			●
R/L ZW11.12061500	1.2	6	15°	●			●
R/L ZW11.15081500	1.5	8	15°	●			●
R/L ZW11.15161500	1.5	16	15°	●			●
R/L ZW11.18081500	1.8	8	15°	●			●
R/L ZW11.20101500	2.0	10	15°	●			●
R/L ZW11.20161500	2.0	16	15°	●			●
R/L ZW11.25131500	2.5	13	15°	●			●
R/L ZW11.25161500	2.5	16	15°	●			●
R/L ZW11.30161500	3.0	16	15°	●			●

R/L HW10...
R/L HW15...
R/L HW20...

Weitere HM Sorten können Sie in der Sorten-
übersicht im Kapitel "Technische Hinweise" und
der Preisliste finden.

Bestellbeispiel:
für rechte Ausführung und Sorte
RZW11.08061500/P18C

More carbide grades you can find in the grades
summary in the chapter "technical instructions"
and in the price list.

order-example:
righthand version and grade
RZW11.08061500/P18C

SWISSLINE

Miniatúraußenbearbeitung,
zweischneidig

miniature external machining,
two-cutting edges

Typ ZW12

Wendeschneidplatten,
zum Abstechen
mit Gegenspindel

indexable inserts,
for parting off
with counter spindle

Stechtiefe t max. = 6 mm
Stechbreite b = 0.8 / 1.2 mm

depth of groove t max. = 6 mm
width of groove b = 0.8 / 1.2 mm

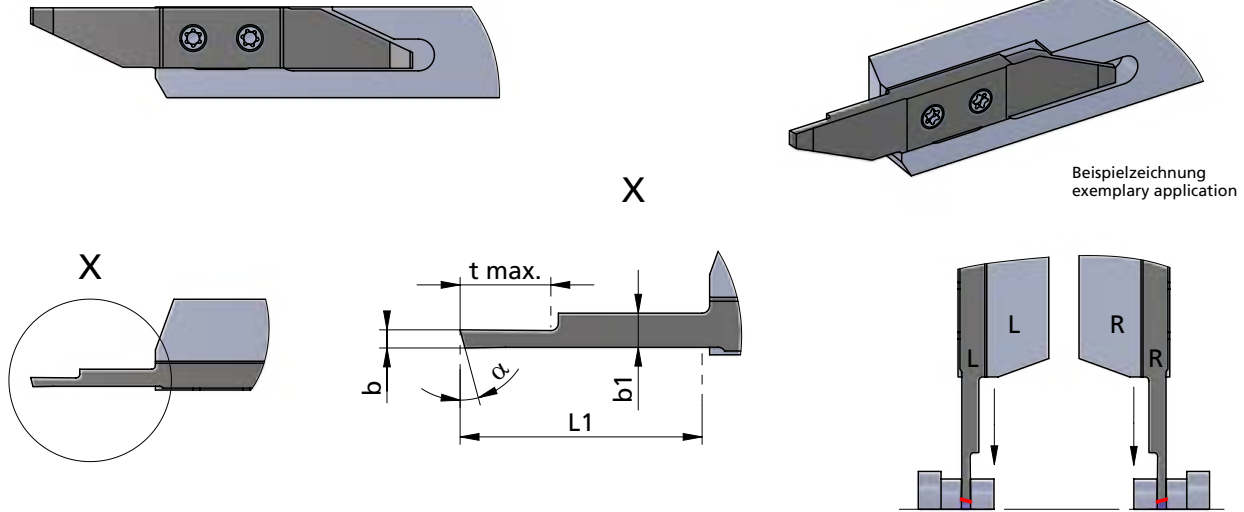

Rechts (R): wie gezeichnet
Links (L): spiegelbildlich

Rechte Schneidpl. in rechtem Halter
Linke Schneidpl. in linkem Halter

Abmessungen in mm

righthand version (R): as shown
lefthand version (L): mirror image

use RH insert in RH tool holder and
LH insert in LH tool holder

dimensions in mm



Bestellnummer part number	b	t max.	α	L1	b1	Klemmhalter Typ toolholder type				
						K10F	CN45F	AL41F	P18C	
R/L ZW12.08061500	0.8	6	15°	16	2.0	●		●		R/L HW10... R/L HW15... R/L HW20...
R/L ZW12.12061500	1.2	6	15°	16	2.4	●		●		

Weitere HM Sorten können Sie in der Sortenübersicht im Kapitel "Technische Hinweise" und der Preisliste finden.

Bestellbeispiel:
für rechte Ausführung und Sorte
RZW12.08061500/P18C

More carbide grades you can find in the grades summary in the chapter "technical instructions" and in the price list.

order-example:
righthand version and grade
RZW12.08061500/P18C

SWISSLINE

Miniatöraußenbearbeitung,
zweischneidig

miniature external machining,
two-cutting edges

Typ ZW13

Wendeschneidplatten,
zum Abstechen mit Gegenspindel,
Schneide versetzt

indexable inserts,
for parting off with counter spindle,
offset cutting edge

Stechtiefe t max. = 6 mm
Stechbreite b = 0.8 / 1.2 mm

depth of groove t max. = 6 mm
width of groove b = 0.8 / 1.2 mm

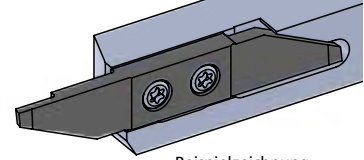
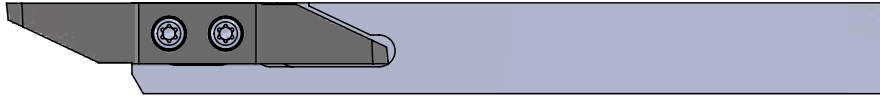

Beispielzeichnung
exemplary application

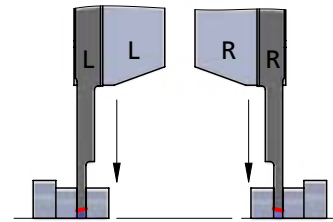
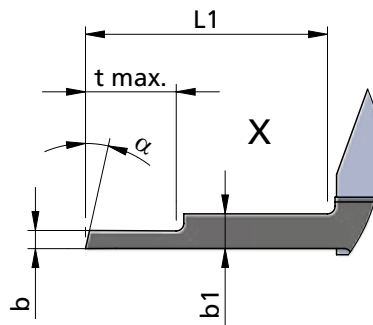
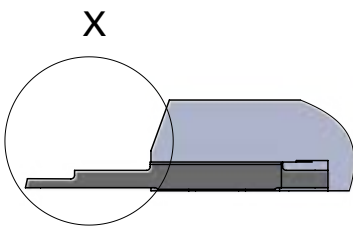

Rechts (R): wie gezeichnet
Links (L): spiegelbildlich

Rechte Schneidpl. in rechtem Halter
Linke Schneidpl. in linkem Halter

Abmessungen in mm

righthand version (R): as shown
lefthand version (L): mirror image

use RH insert in RH tool holder and
LH insert in LH tool holder

dimensions in mm



Bestellnummer part number	b	t max.	α	L1	b1	Klemmhalter Typ toolholder type				
						K10F	CN45F	AL41F	P18C	
R/L ZW13.08061500	0.8	6	15°	16	2.0	●		●		R/L HW10... R/L HW15... R/L HW20...
R/L ZW13.12061500	1.2	6	15°	16	2.4	●		●		

Weitere HM Sorten können Sie in der Sorten-
übersicht im Kapitel "Technische Hinweise" und
der Preisliste finden.

Bestellbeispiel:
für rechte Ausführung und Sorte
RZW13.08061500/P18C

More carbide grades you can find in the grades
summary in the chapter "technical instructions"
and in the price list.

order-example:
righthand version and grade
RZW13.08061500/P18C

SWISSLINE

Miniatúraußenbearbeitung,
zweischneidig

miniature external machining,
two-cutting edges

Typ ZW14

Wendeschneidplatten,
zum Abstechen,
mit Spanformer

indexable inserts,
for parting off,
with chip former

Stechtiefe t max. = 8 - 16 mm
Stechbreite b = 1.5 - 3 mm

depth of groove t max. = 8 - 16 mm
width of groove b = 1.5 - 3 mm

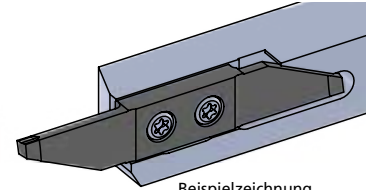
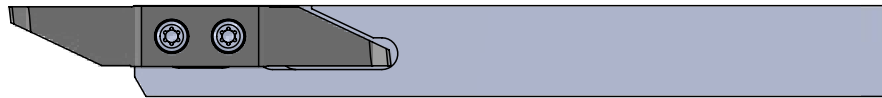

Beispielzeichnung
exemplary application

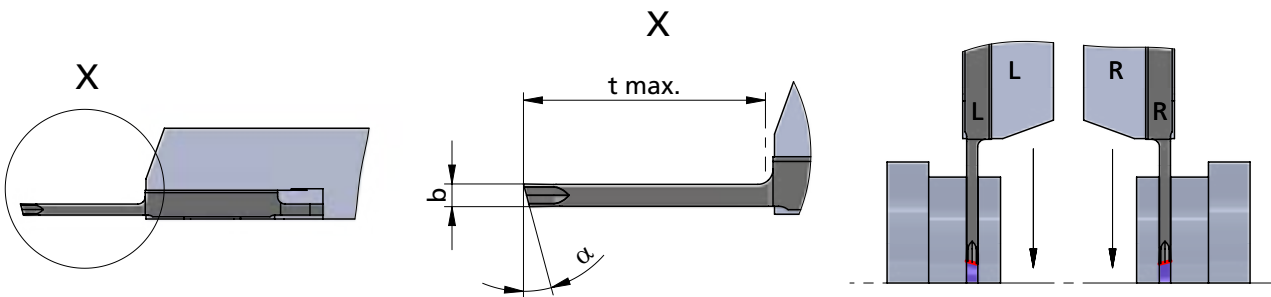

Rechts (R): wie gezeichnet
Links (L): spiegelbildlich

Rechte Schneidpl. in rechtem Halter
Linke Schneidpl. in linkem Halter

Abmessungen in mm

righthand version (R): as shown
lefthand version (L): mirror image

use RH insert in RH tool holder and
LH insert in LH tool holder

dimensions in mm



Bestellnummer part number	b	t max.	α					Klemmhalter Typ toolholder type
				K10F	CN45F	AL41F	P18C	
R/L ZW14.15081500	1.5	8	15°	●			●	R/L HW10... R/L HW15... R/L HW20...
R/L ZW14.15161500	1.5	16	15°	●			●	
R/L ZW14.20101500	2.0	10	15°	●			●	
R/L ZW14.20161500	2.0	16	15°	●			●	
R/L ZW14.25131500	2.5	13	15°	●			●	
R/L ZW14.25161500	2.5	16	15°	●			●	
R/L ZW14.30161500	3.0	16	15°	●			●	

Weitere HM Sorten können Sie in der Sorten-
übersicht im Kapitel "Technische Hinweise" und
der Preisliste finden.

Bestellbeispiel:
für rechte Ausführung und Sorte
RZW14.15081500/P18C

More carbide grades you can find in the grades
summary in the chapter "technical instructions"
and in the price list.

order-example:
righthand version and grade
RZW14.15081500/P18C

SWISSLINE

Miniatúraußenbearbeitung,
zweischneidig

miniature external machining,
two-cutting edges

Typ ZW15

Wendeschneidplatten,
zum Abstechen,
Schneide versetzt, mit Spanformer

indexable inserts,
for parting off,
offset cutting edge, with chip former

Stechtiefe t max. = 8 - 16 mm
Stechbreite b = 1.5 - 3 mm

depth of groove t max. = 8 - 16 mm
width of groove b = 1.5 - 3 mm

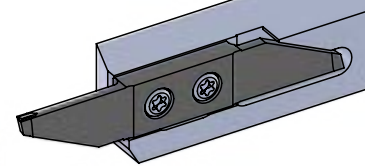
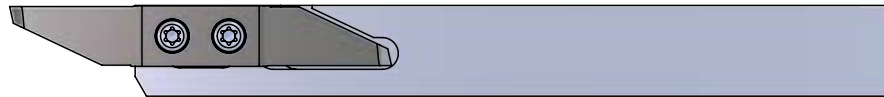

Beispielzeichnung
exemplary application

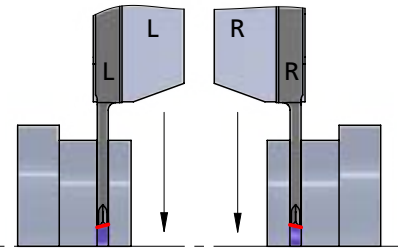
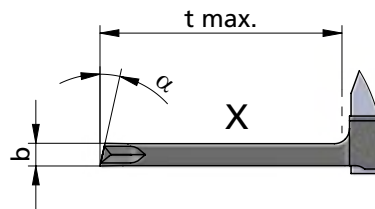
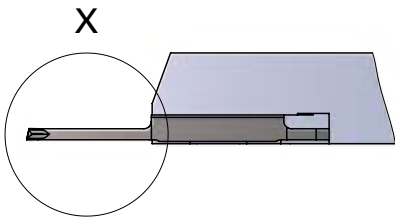

Rechts (R): wie gezeichnet
Links (L): spiegelbildlich

Rechte Schneidpl. in rechtem Halter
Linke Schneidpl. in linkem Halter

Abmessungen in mm

righthand version (R): as shown
lefthand version (L): mirror image

use RH insert in RH tool holder and
LH insert in LH tool holder

dimensions in mm



Bestellnummer part number	b	t max.	α	Klemmhalter Typ toolholder type			
				K10F	CN45F	AL41F	P18C
R/L ZW15.15081500	1.5	8	15°	●			●
R/L ZW15.15161500	1.5	16	15°	●			●
R/L ZW15.20101500	2.0	10	15°	●			●
R/L ZW15.20161500	2.0	16	15°	●			●
R/L ZW15.25131500	2.5	13	15°	●			●
R/L ZW15.25161500	2.5	16	15°	●			●
R/L ZW15.30161500	3.0	16	15°	●			●

Weitere HM Sorten können Sie in der Sorten-
übersicht im Kapitel "Technische Hinweise" und
der Preisliste finden.

Bestellbeispiel:
für rechte Ausführung und Sorte
RZW15.15081500/P18C

More carbide grades you can find in the grades
summary in the chapter "technical instructions"
and in the price list.

order-example:
righthand version and grade
RZW15.15081500/P18C

SWISSLINE

Miniatúraußenbearbeitung,
zweischneidig

miniature external machining,
two-cutting edges

Typ ZW16

Wendeschneidplatten,
zum Abstechen,
mit Spantreppe

indexable inserts,
for parting off,
with chip breaker

Stechtiefe t max. = 8 - 16 mm
Stechbreite b = 1.5 - 3 mm

depth of groove t max. = 8 - 16 mm
width of groove b = 1.5 - 3 mm

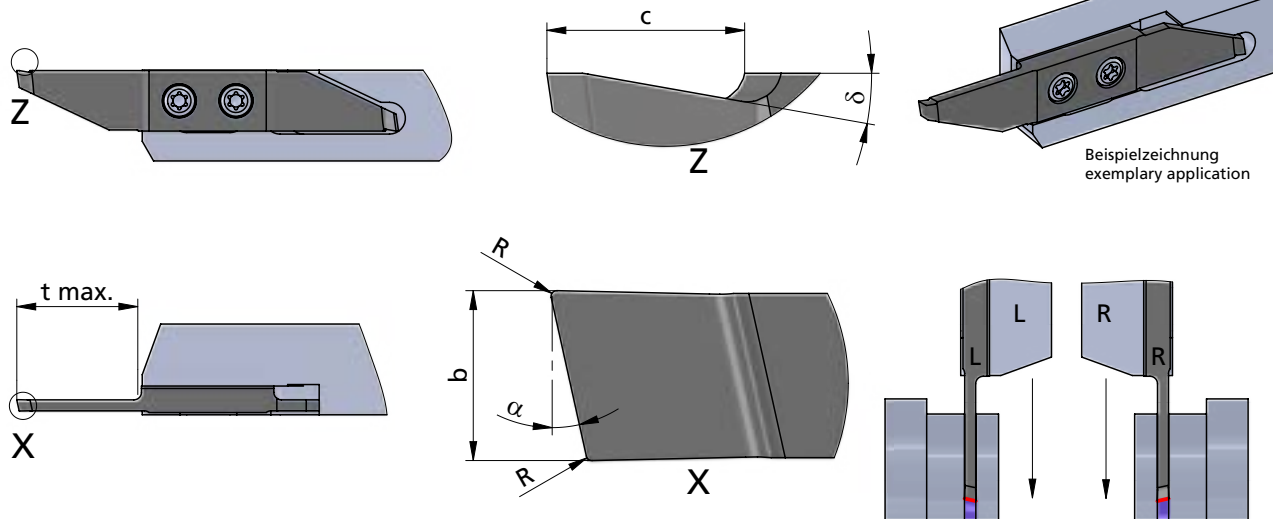

Rechts (R): wie gezeichnet
Links (L): spiegelbildlich

Rechte Schneidpl. in rechtem Halter
Linke Schneidpl. in linkem Halter

Abmessungen in mm

righthand version (R): as shown
lefthand version (L): mirror image

use RH insert in RH tool holder and
LH insert in LH tool holder

dimensions in mm



Bestellnummer part number	b	t max.	δ	R	α	c	Klemmhalter Typ toolholder type				
							K10F	CN45F	AL41F	P18C	
R/L ZW16.15080605	1.5	8	6°	0.05	15°	2	●				
R/L ZW16.15081205	1.5	8	12°	0.05	15°	2	●				
R/L ZW16.20100605	2.0	10	6°	0.05	15°	2	●				
R/L ZW16.20101205	2.0	10	12°	0.05	15°	2	●				
R/L ZW16.20102000	2.0	10	20°	-	15°	2	●				
R/L ZW16.20160605	2.0	16	6°	0.05	15°	2	●				
R/L ZW16.20161205	2.0	16	12°	0.05	15°	2	●				R/L HW10... R/L HW15... R/L HW20...
R/L ZW16.25130605	2.5	13	6°	0.05	15°	2	●				
R/L ZW16.25131205	2.5	13	12°	0.05	15°	2	●				
R/L ZW16.25160605	2.5	16	6°	0.05	15°	2	●				
R/L ZW16.25161205	2.5	16	12°	0.05	15°	2	●				
R/L ZW16.30160605	3.0	16	6°	0.05	15°	2	●				
R/L ZW16.30161205	3.0	16	12°	0.05	15°	2	●				

Weitere HM Sorten können Sie in der Sortenübersicht im Kapitel "Technische Hinweise" und der Preisliste finden.

Bestellbeispiel:
für rechte Ausführung und Sorte
RZW16.15080605/P18C

More carbide grades you can find in the grades summary in the chapter "technical instructions" and in the price list.

order-example:
righthand version and grade
RZW16.15080605/P18C

SWISSLINE

Miniatúraußenbearbeitung,
zweischneidig

miniature external machining,
two-cutting edges

Typ ZW17

Wendeschneidplatten,
zum Abstechen,
Schneide versetzt, mit Spantreppe

indexable inserts,
for parting off,
offset cutting edge, with chip breaker

Stechtiefe t max. = 8 - 16 mm
Stechbreite b = 1.5 - 3 mm

depth of groove t max. = 8 - 16 mm
width of groove b = 1.5 - 3 mm

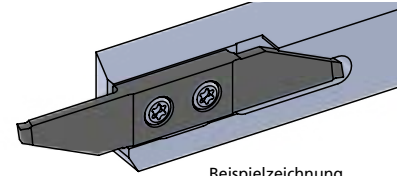
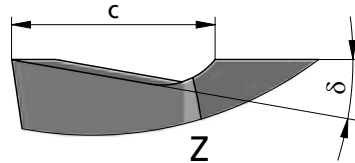
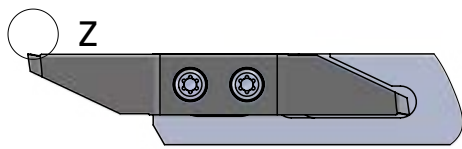

Beispielzeichnung
exemplary application

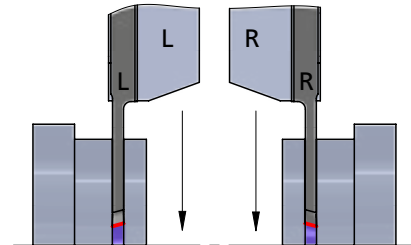
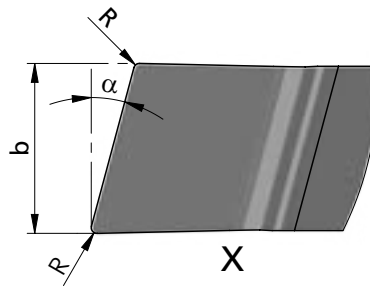
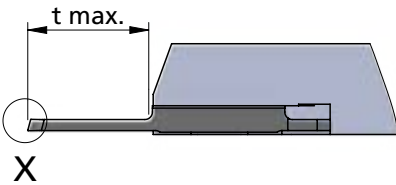

Rechts (R): wie gezeichnet
Links (L): spiegelbildlich

Rechte Schneidpl. in rechtem Halter
Linke Schneidpl. in linkem Halter

Abmessungen in mm

righthand version (R): as shown
lefthand version (L): mirror image

use RH insert in RH tool holder and
LH insert in LH tool holder

dimensions in mm



Bestellnummer part number	b	t max.	delta	R	alpha	c	Klemmhalter Typ toolholder type				
							K10F	CN45F	AL41F	P18C	
R/L ZW17.15080605	1.5	8	6°	0.05	15°	2	●				
R/L ZW17.15081205	1.5	8	12°	0.05	15°	2	●				
R/L ZW17.20100605	2.0	10	6°	0.05	15°	2	●				
R/L ZW17.20101205	2.0	10	12°	0.05	15°	2	●				
R/L ZW17.20160605	2.0	16	6°	0.05	15°	2	●				
R/L ZW17.20161205	2.0	16	12°	0.05	15°	2	●				
R/L ZW17.25130605	2.5	13	6°	0.05	15°	2	●				
R/L ZW17.25131205	2.5	13	12°	0.05	15°	2	●				
R/L ZW17.25160605	2.5	16	6°	0.05	15°	2	●				
R/L ZW17.25161205	2.5	16	12°	0.05	15°	2	●				
R/L ZW17.30160605	3.0	16	6°	0.05	15°	2	●				
R/L ZW17.30161205	3.0	16	12°	0.05	15°	2	●				

Weitere HM Sorten können Sie in der Sortenübersicht im Kapitel "Technische Hinweise" und der Preisliste finden.

Bestellbeispiel:
für rechte Ausführung und Sorte
RZW17.15080605/P18C

More carbide grades you can find in the grades summary in the chapter "technical instructions" and in the price list.

order-example:
righthand version and grade
RZW17.15080605/P18C

SWISSLINE

Miniatúraußenbearbeitung,
zweischneidig

miniature external machining,
two-cutting edges

Typ ZW18

Wendeschneidplatten,
zum Abstechen unter 0°,
mit Spanformer

indexable inserts,
for parting off with 0°,
with chip former

Stechtiefe t max. = 10 - 16 mm
Stechbreite b = 1.5 - 3 mm

depth of groove t max. = 10 - 16 mm
width of groove b = 1.5 - 3 mm

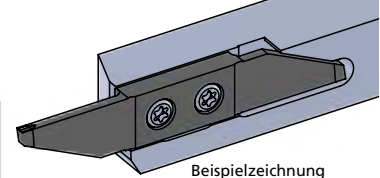
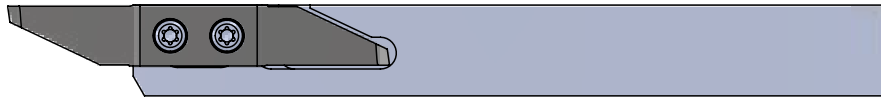

Beispielzeichnung
exemplary application

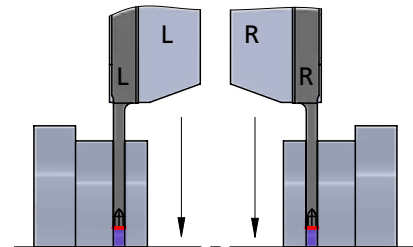
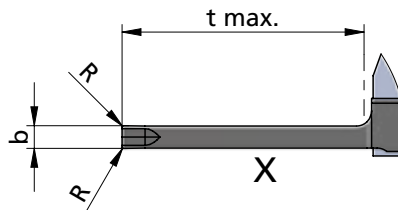
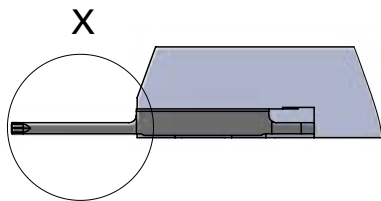

Rechts (R): wie gezeichnet
Links (L): spiegelbildlich

Rechte Schneidpl. in rechtem Halter
Linke Schneidpl. in linkem Halter

Abmessungen in mm

righthand version (R): as shown
lefthand version (L): mirror image

use RH insert in RH tool holder and
LH insert in LH tool holder

dimensions in mm



Bestellnummer part number	b	t max.	R	Klemmhalter Typ toolholder type			
				K10F	CN45F	AL41F	P18C
R/L ZW18.15100008	1.5	10	0.08	●			●
R/L ZW18.15160008	1.5	16	0.08	●			●
R/L ZW18.20100008	2.0	10	0.08	●			●
R/L ZW18.20160008	2.0	16	0.08	●			●
R/L ZW18.25130008	2.5	13	0.08	●			●
R/L ZW18.25160008	2.5	16	0.08	●			●
R/L ZW18.30160008	3.0	16	0.08	●			●

Weitere HM Sorten können Sie in der Sorten-
übersicht im Kapitel "Technische Hinweise" und
der Preisliste finden.

Bestellbeispiel:
für rechte Ausführung und Sorte
RZW18.15100008/P18C

More carbide grades you can find in the grades
summary in the chapter "technical instructions"
and in the price list.

order-example:
righthand version and grade
RZW18.15100008/P18C

SWISSLINE

Miniatúraußenbearbeitung,
zweischneidig

miniature external machining,
two-cutting edges

Typ ZW19

Wendeschneidplatten,
zum Abstechen unter 0°,
mit Spantrepe

indexable inserts,
for parting off with 0°,
with chip breaker

Stechtiefe t max. = 10 - 16 mm
Stechbreite b = 1.5 - 3 mm

depth of groove t max. = 10 - 16 mm
width of groove b = 1.5 - 3 mm

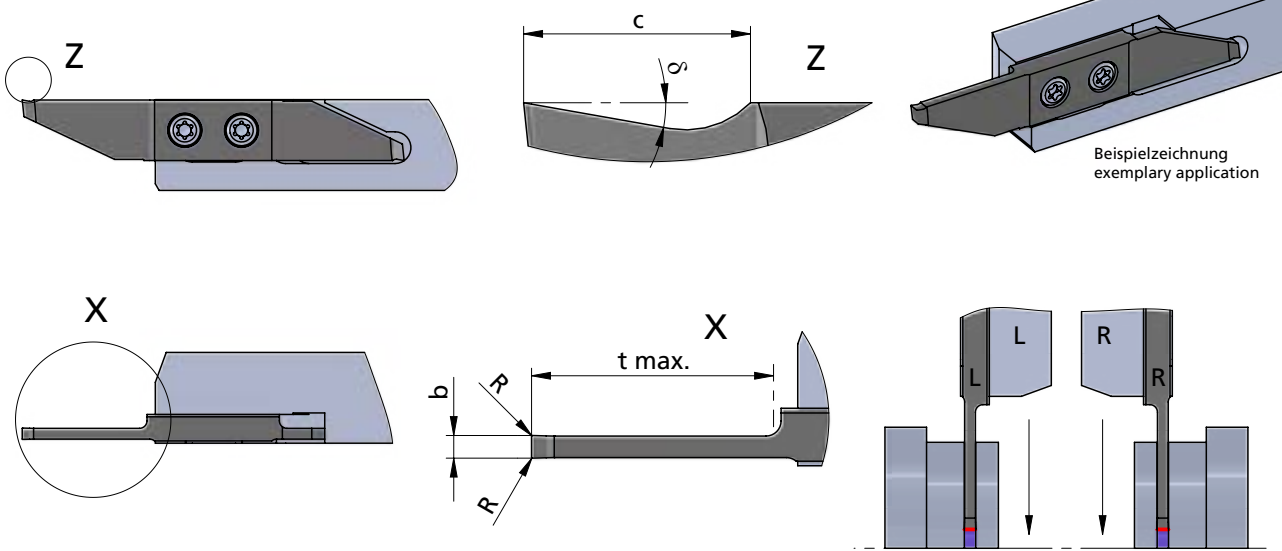

Rechts (R): wie gezeichnet
Links (L): spiegelbildlich

Rechte Schneidpl. in rechtem Halter
Linke Schneidpl. in linkem Halter

Abmessungen in mm

righthand version (R): as shown
lefthand version (L): mirror image

use RH insert in RH tool holder and
LH insert in LH tool holder

dimensions in mm



Bestellnummer part number	b	t max.	φ	R	c	Klemmhalter Typ toolholder type			
						K10F	CN45F	AL41F	P18C
R/L ZW19.15100605	1.5	10	6°	0.05	2	●			
R/L ZW19.15101205	1.5	10	12°	0.05	2	●			
R/L ZW19.20100605	2.0	10	6°	0.05	2	●			
R/L ZW19.20101205	2.0	10	12°	0.05	2	●			
R/L ZW19.20160605	2.0	16	6°	0.05	2	●			
R/L ZW19.20161205	2.0	16	12°	0.05	2	●			
R/L ZW19.25130605	2.5	13	6°	0.05	2	●			
R/L ZW19.25131205	2.5	13	12°	0.05	2	●			
R/L ZW19.25160605	2.5	16	6°	0.05	2	●			
R/L ZW19.25161205	2.5	16	12°	0.05	2	●			
R/L ZW19.30160605	3.0	16	6°	0.05	2	●			
R/L ZW19.30161205	3.0	16	12°	0.05	2	●			

R/L HW10, ...
R/L HW15, ...
R/L HW20, ...

Weitere HM Sorten können Sie in der Sorten-
übersicht im Kapitel "Technische Hinweise" und
der Preisliste finden.

Bestellbeispiel:
für rechte Ausführung und Sorte
RZW19.15100605/P18C

More carbide grades you can find in the grades
summary in the chapter "technical instructions"
and in the price list.

order-example:
righthand version and grade
RZW19.15100605/P18C

SWISSLINE

Miniatúraußenbearbeitung,
zweischneidig

miniature external machining,
two-cutting edges

Typ ZW1A

Wendeschneidplatten,
zum Abstechen,
mit gesintertem Spanformer

indexable inserts,
for parting off,
with sintered chipformer

Stechtiefe t max. = 10 mm
Stechbreite b = 2 mm

depth of groove t max. = 10 mm
width of groove b = 2 mm



R/L ZW1A.201015GS: Schneide mit scharfer Schneidkante /
insert with sharp cutting edge

R/L ZW1A.201015GX: Schneide mit gerundeter Schneidkante /
insert with rounded cutting edge

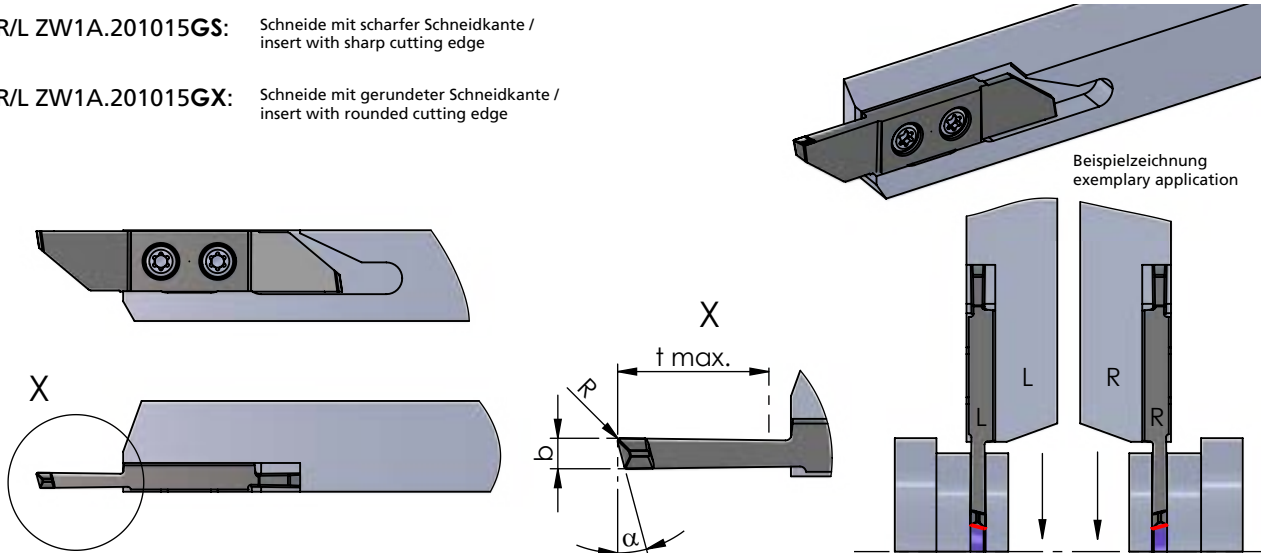

Rechts (R): wie gezeichnet
Links (L): spiegelbildlich

Rechte Schneidpl. in rechtem Halter
Linke Schneidpl. in linkem Halter

Abmessungen in mm

righthand version (R): as shown
lefthand version (L): mirror image

use RH insert in RH tool holder and
LH insert in LH tool holder

dimensions in mm



Bestellnummer part number	b	t max.	α	R	Klemmhalter Typ toolholder type			
					K10F	CN45F	AL41F	P18C
R/L ZW1A.201015GS	2.0	10	15°	0.2	●		●	R/L HW10... R/L HW15... R/L HW20...
R/L ZW1A.201015GX	2.0	10	15°	0.2	●		●	

Weitere HM Sorten können Sie in der Sorten-
übersicht im Kapitel "Technische Hinweise" und
der Preisliste finden.

Bestellbeispiel:
für rechte Ausführung und Sorte
RZW1A.201015GS/P18C

More carbide grades you can find in the grades
summary in the chapter "technical instructions"
and in the price list.

order-example:
righthand version and grade
RZW1A.201015GS/P18C

SWISSLINE

Miniatöraußenbearbeitung,
zweischneidig

miniature external machining,
two-cutting edges

Typ ZW1B

Wendeschneidplatten,
zum Abstechen, Schneide versetzt,
mit gesintertem Spanformer

indexable inserts,
for parting off, offset cutting edge,
with sintered chipformer

Stechtiefe $t \text{ max.} = 10 \text{ mm}$
Stechbreite $b = 2 \text{ mm}$

depth of groove $t \text{ max.} = 10 \text{ mm}$
width of groove $b = 2 \text{ mm}$

R/L ZW1B.201015GS: Schneide mit scharfer Schneidkante /
insert with sharp cutting edge

R/L ZW1B.201015GX: Schneide mit gerundeter Schneidkante /
insert with rounded cutting edge

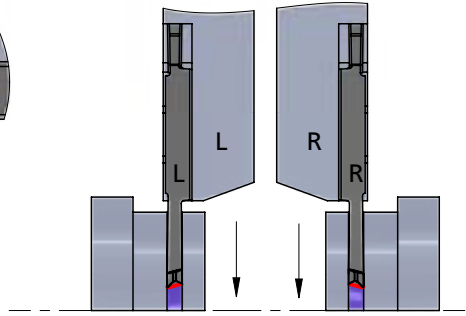
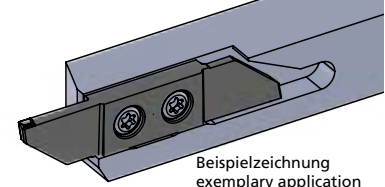
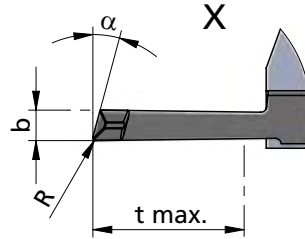
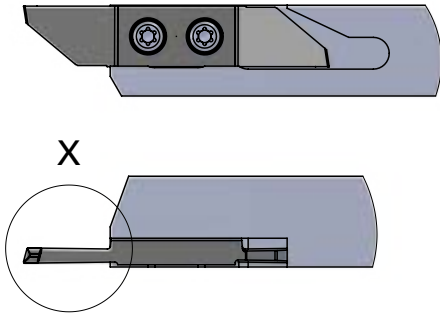

Rechts (R): wie gezeichnet
Links (L): spiegelbildlich

Rechte Schneidpl. in rechtem Halter
Linke Schneidpl. in linkem Halter

Abmessungen in mm

righthand version (R): as shown
lefthand version (L): mirror image

use RH insert in RH tool holder and
LH insert in LH tool holder

dimensions in mm



Bestellnummer part number	b	t max.	α	R	Klemmhalter Typ toolholder type				
					K10F	CN45F	AL41F	P18C	
R/L ZW1B.201015GS	2.0	10	15°	0.2	●	●	●	●	R/L HW10... R/L HW15... R/L HW20...
R/L ZW1B.201015GX	2.0	10	15°	0.2	●	●	●	●	

Weitere HM Sorten können Sie in der Sorten-
übersicht im Kapitel "Technische Hinweise" und
der Preisliste finden.

Bestellbeispiel:
für rechte Ausführung und Sorte
RZW1B.201015GS/P18C

More carbide grades you can find in the grades
summary in the chapter "technical instructions"
and in the price list.

order-example:
righthand version and grade
RZW1B.201015GS/P18C

SWISSLINE

Miniatöraußenbearbeitung,
zweischneidig

miniature external machining,
two-cutting edges

Typ ZW1C

Wendeschneidplatten,
zum Abstechen unter 0°,
mit gesintertem Spanformer

indexable inserts,
for parting off with 0°,
with sintered chip former

Stechtiefe t max. = 10 mm
Stechbreite b = 2 mm

depth of groove t max. = 10 mm
width of groove b = 2 mm



R/L ZW1C.201000GS: Schneide mit scharfer Schneidkante /
insert with sharp cutting edge

R/L ZW1C.201000GX: Schneide mit gerundeter Schneidkante /
insert with rounded cutting edge

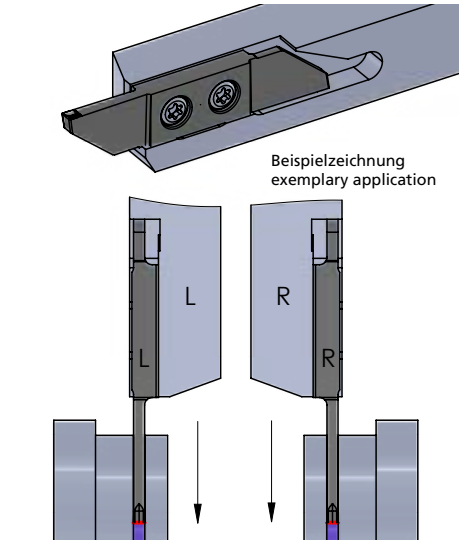
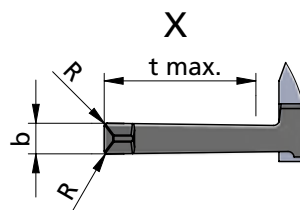
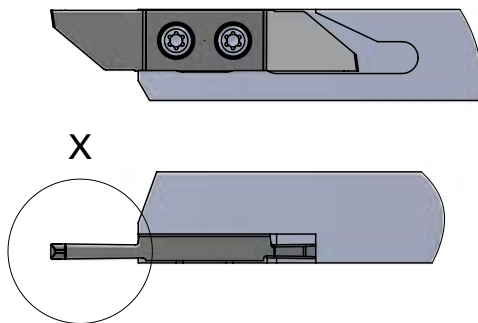

Rechts (R): wie gezeichnet
Links (L): spiegelbildlich

Rechte Schneidpl. in rechtem Halter
Linke Schneidpl. in linkem Halter

Abmessungen in mm

righthand version (R): as shown
lefthand version (L): mirror image

use RH insert in RH tool holder and
LH insert in LH tool holder

dimensions in mm



Bestellnummer part number	b	t max.	R	Klemmhalter Typ toolholder type			
				K10F	CN45F	AL41F	P18C
R/L ZW1C.201000GS	2.0	10	0.2	●	●	●	●
R/L ZW1C.201000GX	2.0	10	0.2	●	●	●	●

Weitere HM Sorten können Sie in der Sorten-
übersicht im Kapitel "Technische Hinweise" und
der Preisliste finden.

Bestellbeispiel:
für rechte Ausführung und Sorte
RZW1C.201000GS/P18C

More carbide grades you can find in the grades
summary in the chapter "technical instructions"
and in the price list.

order-example:
righthand version and grade
RZW1C.201000GS/P18C

SWISSLINE

Miniaturaußenbearbeitung,
zweischneidig

miniature external machining,
two-cutting edges

Typ ZW20

Wendeschneidplatten,
Drehen und Abstechen,
Wipergeometrie

indexable inserts,
turning and parting off,
wiper geometry

Stechtiefe t max. = 10 mm
Stechbreite b = 2 mm

depth of groove t max. = 10 mm
width of groove b = 2 mm

Wipergeometrie
siehe: Beschreibung
Schneidenausführung

wiper geometry
see: description of
the cutting types

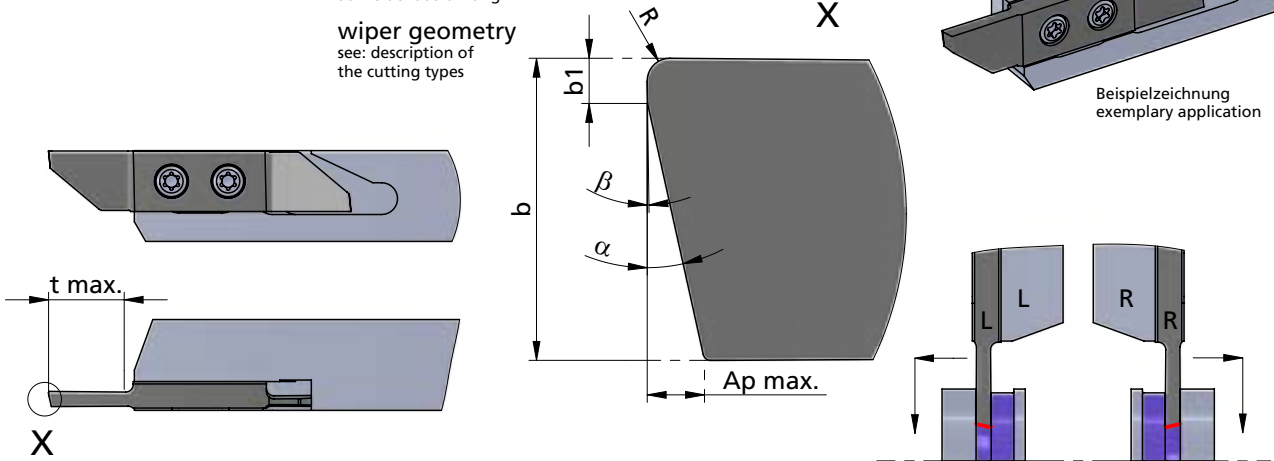

Beispielzeichnung
exemplary application

Rechts (R): wie gezeichnet
Links (L): spiegelbildlich

Rechte Schneidpl. in rechtem Halter
Linke Schneidpl. in linkem Halter

Abmessungen in mm

righthand version (R): as shown
lefthand version (L): mirror image

use RH insert in RH tool holder and
LH insert in LH tool holder

dimensions in mm

Bestellnummer part number	b	t max.	α	R	β	b1	Ap max. *	Klemmhalter Typ toolholder type				
								K10F	CN45F	AL41F	P18C	
R/L ZW20.20101515	2	10	15°	0.15	1.5°	0.3	0.45	●		●		R/L HW10... R/L HW15... R/L HW20...

*Ap max. = max. Schnitttiefe(werkstoffabhängig)

Weitere HM Sorten können Sie in der Sorten-
übersicht im Kapitel "Technische Hinweise" und
der Preisliste finden.

Bestellbeispiel: für rechte Ausführung und Sorte
RZW20.20101515/P18C

*Ap max. = maximum depth of cut
(depending on material)

More carbide grades you can find in the grades
summary in the chapter "technical instructions"
and in the price list.
order-example: righthand version and grade
RZW20.20101515/P18C

SWISSLINE

Miniaturaußenbearbeitung,
zweischneidig

miniature external machining,
two-cutting edges

Typ ZW21

Wendeschneidplatten,
Drehen und Abstechen,
Schneide versetzt, Wipergeometrie

indexable inserts,
turning and parting off,
offset cutting edge, wiper geometry

Stechtiefe $t \text{ max.} = 10 \text{ mm}$
Stechbreite $b = 2 \text{ mm}$

depth of groove $t \text{ max.} = 10 \text{ mm}$
width of groove $b = 2 \text{ mm}$

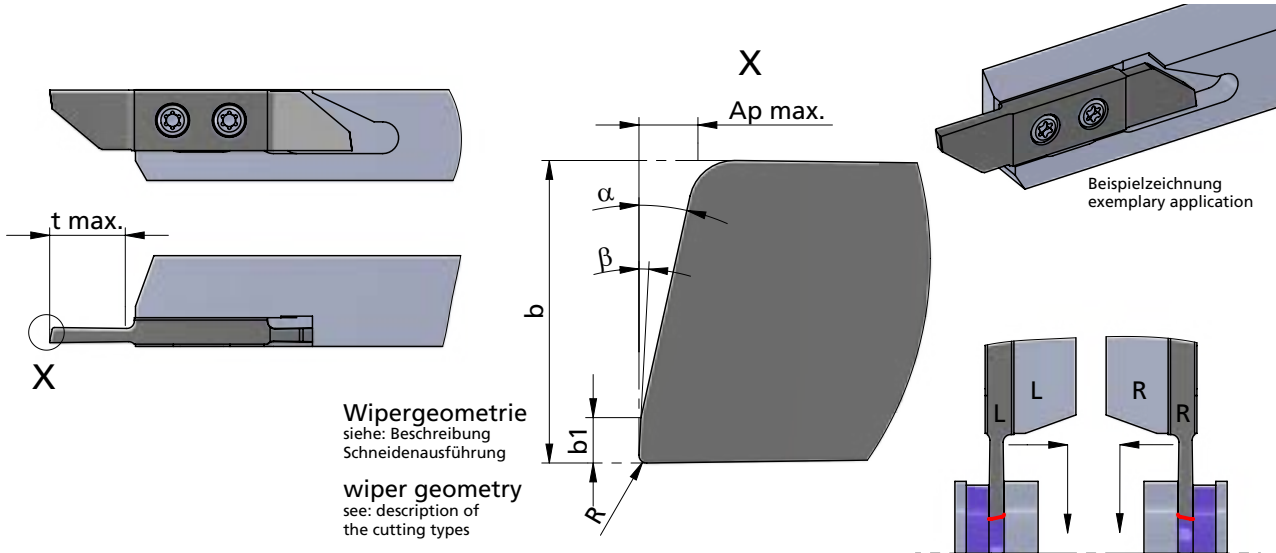

Rechts (R): wie gezeichnet
Links (L): spiegelbildlich

Rechte Schneidpl. in rechtem Halter
Linke Schneidpl. in linkem Halter

Abmessungen in mm

righthand version (R): as shown
lefthand version (L): mirror image

use RH insert in RH tool holder and
LH insert in LH tool holder

dimensions in mm

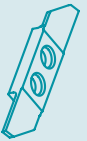

Bestellnummer part number	b	t max.	α	R	β	b1	Ap max. *	Klemmhalter Typ toolholder type			
								K10F	CN45F	AL41F	P18C
R/L ZW21.20101515	2	10	15°	0.15	1.5°	0.3	0.45	●		●	R/L HW10... R/L HW15... R/L HW20...

*Ap max. = max. Schnitttiefe(werkstoffabhängig)

Weitere HM Sorten können Sie in der Sorten-
übersicht im Kapitel "Technische Hinweise" und
der Preisliste finden.

Bestellbeispiel: für rechte Ausführung und Sorte
RZW21.20101515/P18C

*Ap max. = maximum depth of cut
(depending on material)

More carbide grades you can find in the grades
summary in the chapter "technical instructions"
and in the price list.
order-example: righthand version and grade
RZW21.20101515/P18C

SWISSLINE

Miniaturaußenbearbeitung,
zweischneidig

miniature external machining,
two-cutting edges

Typ ZW22

Wendeschneidplatten,
Drehen und Abstechen,
mit Spanformer, Wipergeometrie

indexable inserts,
turning and parting off,
with chipformer, wiper geometry

Stechtiefe t max. = 10 mm
Stechbreite b = 2 mm

depth of groove t max. = 10 mm
width of groove b = 2 mm

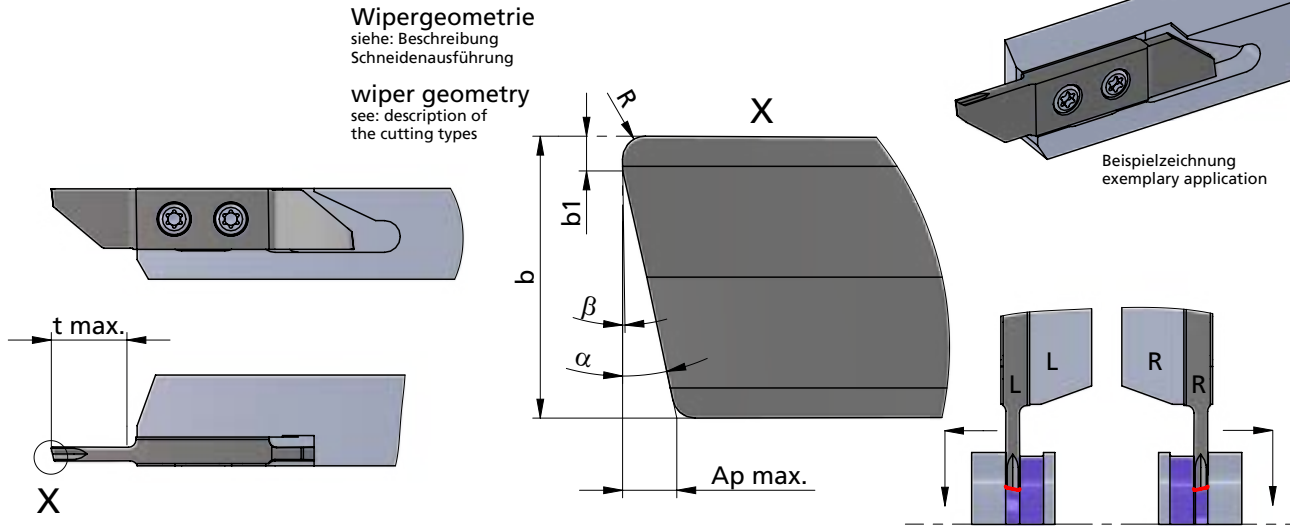

Rechts (R): wie gezeichnet
Links (L): spiegelbildlich

Rechte Schneidpl. in rechtem Halter
Linke Schneidpl. in linkem Halter

Abmessungen in mm

righthand version (R): as shown
lefthand version (L): mirror image

use RH insert in RH tool holder and
LH insert in LH tool holder

dimensions in mm

Bestellnummer part number	b	t max.	α	R	β	b1	Ap max. *	Klemmhalter Typ toolholder type			
								K10F	CN45F	AL41F	P18C
R/L ZW22.20101515	2	10	15°	0.15	1.5°	0.3	0.45	●		●	R/L HW10... R/L HW15... R/L HW20...

*Ap max. = max. Schnitttiefe(werkstoffabhängig)

Weitere HM Sorten können Sie in der Sorten-
übersicht im Kapitel "Technische Hinweise" und
der Preisliste finden.

Bestellbeispiel: für rechte Ausführung und Sorte
RZW22.20101515/P18C

*Ap max. = maximum depth of cut
(depending on material)

More carbide grades you can find in the grades
summary in the chapter "technical instructions"
and in the price list.
order-example: righthand version and grade
RZW22.20101515/P18C

SWISSLINE

Miniatöraußenbearbeitung,
zweischneidig

miniature external machining,
two-cutting edges

Typ ZW23

Wendeschneidplatten,
Drehen u. Abstechen, Schneide versetzt,
mit Spanformer, Wipergeometrie

indexable inserts,
turning and parting off,
offset cutting edge, with chipformer,
wiper geometry

Stechtiefe $t \text{ max.} = 10 \text{ mm}$
Stechbreite $b = 2 \text{ mm}$

depth of groove $t \text{ max.} = 10 \text{ mm}$
width of groove $b = 2 \text{ mm}$

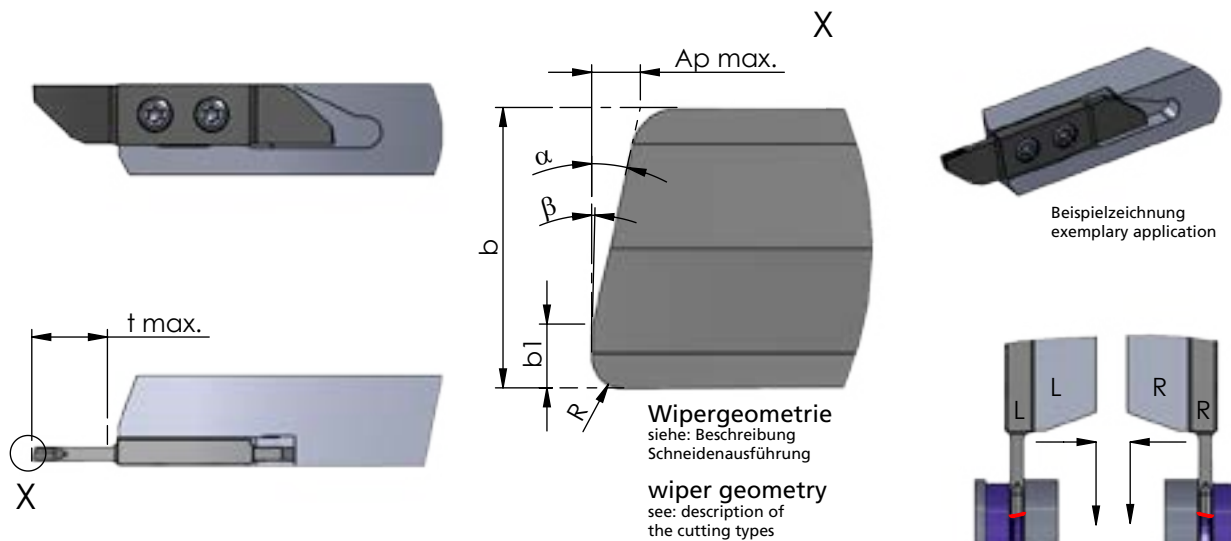

Rechts (R): wie gezeichnet
Links (L): spiegelbildlich

Rechte Schneidpl. in rechtem Halter
Linke Schneidpl. in linkem Halter

Abmessungen in mm

righthand version (R): as shown
lefthand version (L): mirror image

use RH insert in RH tool holder and
LH insert in LH tool holder

dimensions in mm

Bestellnummer part number	b	t max.	α	R	β	b1	Ap max. *	Klemmhalter Typ toolholder type			
								K10F	CN45F	AL41F	P18C
R/L ZW23.20101515	2	10	15°	0.15	1.5°	0.3	0.45	●		●	R/L HW10... R/L HW15... R/L HW20...

*Ap max. = max. Schnitttiefe(werkstoffabhängig)

Weitere HM Sorten können Sie in der Sorten-
übersicht im Kapitel "Technische Hinweise" und
der Preisliste finden.

Bestellbeispiel: für rechte Ausführung und Sorte
RZW23.20101515/P18C

*Ap max. = maximum depth of cut
(depending on material)

More carbide grades you can find in the grades
summary in the chapter "technical instructions"
and in the price list.
order-example: righthand version and grade
RZW23.20101515/P18C



SWISSLINE

Miniaturaußenbearbeitung,
zweischneidig

miniature external machining,
two-cutting edges

Typ ZW30

Wendeschneidplatten,
Vornedrehen

indexable inserts,
turning in front

Stechtiefe t max. = 8 mm
Stechbreite b = 3.4 mm

depth of groove t max. = 8 mm
width of groove b = 3.4 mm

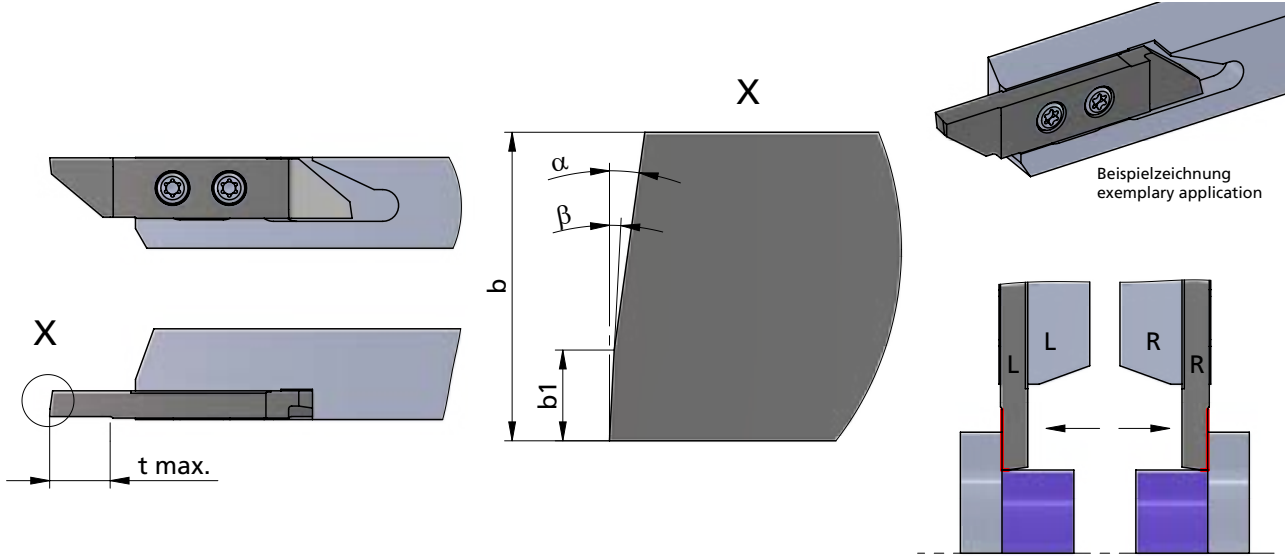

Rechts (R): wie gezeichnet
Links (L): spiegelbildlich

Rechte Schneidpl. in rechtem Halter
Linke Schneidpl. in linkem Halter

Abmessungen in mm

righthand version (R): as shown
lefthand version (L): mirror image

use RH insert in RH tool holder and
LH insert in LH tool holder

dimensions in mm

Bestellnummer part number	b	t max.	α	b1	β	Klemmhalter Typ toolholder type				
						K10F	CN45F	AL41F	P18C	
R/L ZW30.34080800	3.4	8	20°	1	3°	●		●		R/L HW10... R/L HW15... R/L HW20...

Weitere HM Sorten können Sie in der Sorten-
übersicht im Kapitel "Technische Hinweise" und
der Preisliste finden.

Bestellbeispiel:
für rechte Ausführung und Sorte
RZW30.34080800/P18C

More carbide grades you can find in the grades
summary in the chapter "technical instructions"
and in the price list.

order-example:
righthand version and grade
RZW30.34080800/P18C

SWISSLINE

Miniatöraußenbearbeitung,
zweischneidig

miniature external machining,
two-cutting edges

Typ ZW31

Wendeschneidplatten,
Vornedrehen,
mit Spanformer, Wipergeometrie

indexable inserts,
turning in front,
with chip former, wiper geometry

Stechtiefe t max. = 8 mm
Stechbreite b = 3.4 mm

depth of groove t max. = 8 mm
width of groove b = 3.4 mm

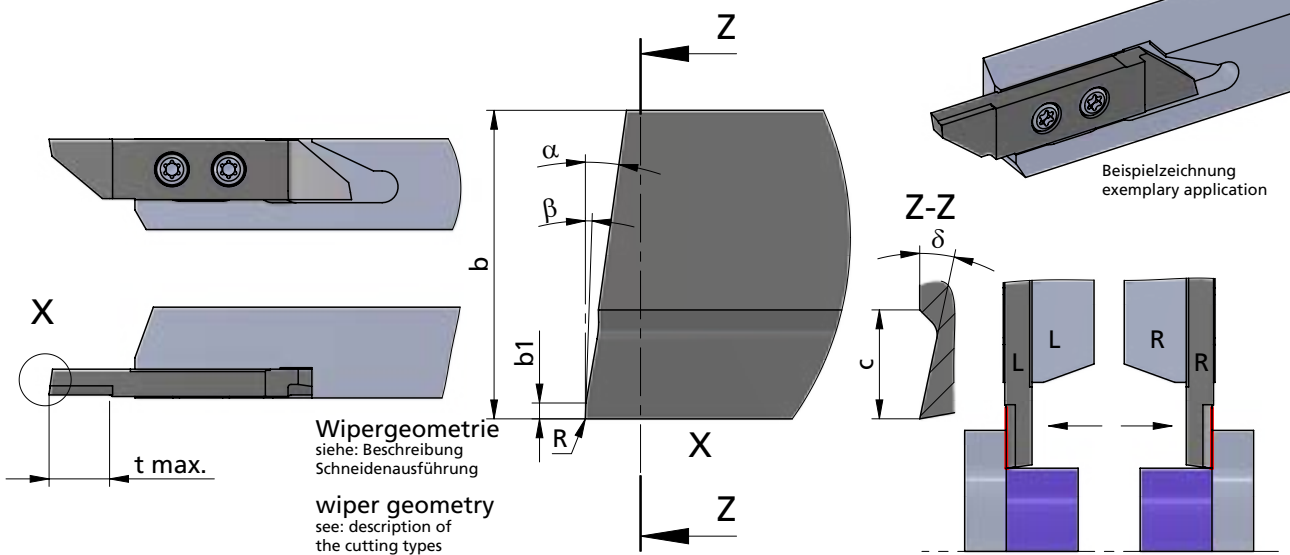

Rechts (R): wie gezeichnet
Links (L): spiegelbildlich

Rechte Schneidpl. in rechtem Halter
Linke Schneidpl. in linkem Halter

Abmessungen in mm

righthand version (R): as shown
lefthand version (L): mirror image

use RH insert in RH tool holder and
LH insert in LH tool holder

dimensions in mm



Bestellnummer part number	b	t max.	α	R	b1	β	c	δ	K10F	CN45F	AL41F	P18C	Klemmhalter Typ	toolholder type
R/L ZW31.34080800	3.4	8	8°	0	0.2	1°	1.2	12°	●			●		R/L HW10...
R/L ZW31.34084508	3.4	8	45°	0.08	1.2	1°	1.2	12°	●			●		R/L HW15...
R/L ZW31.34084515	3.4	8	45°	0.15	1.2	1°	1.2	12°	●			●		R/L HW20...

Weitere HM Sorten können Sie in der Sorten-
übersicht im Kapitel "Technische Hinweise" und
der Preisliste finden.

Bestellbeispiel:
für rechte Ausführung und Sorte
RZW31.34080800/P18C

More carbide grades you can find in the grades
summary in the chapter "technical instructions"
and in the price list.

order-example:
righthand version and grade
RZW31.34080800/P18C

SWISSLINE

Miniatöraußenbearbeitung,
zweischneidig

miniature external machining,
two-cutting edges

Typ ZW40

Wendeschneidplatten,
Kopierdrehen vorne,
Schneide versetzt, mit Spanformer

indexable inserts,
profiling in front,
offset cutting edge, with chip former

Stechtiefe t max. = 11 mm
Stechbreite b = 3.2 mm

depth of groove t max. = 11 mm
width of groove b = 3.2 mm

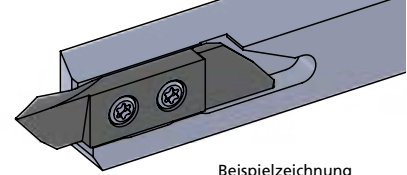
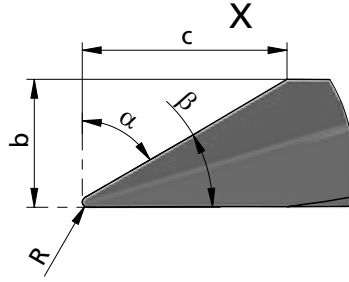
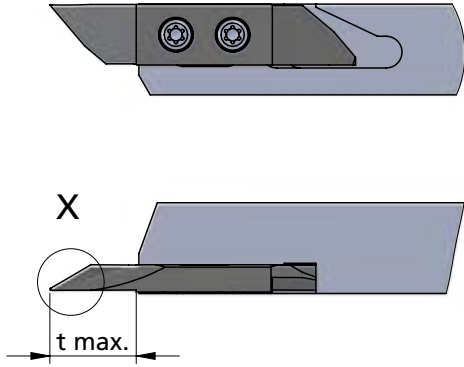

Beispielzeichnung
exemplary application

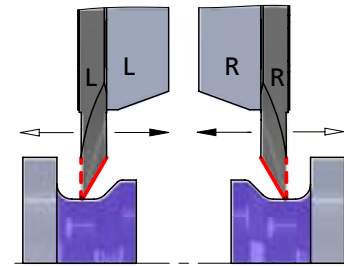

Rechts (R): wie gezeichnet
Links (L): spiegelbildlich

Rechte Schneidpl. in rechtem Halter
Linke Schneidpl. in linkem Halter

Abmessungen in mm

righthand version (R): as shown
lefthand version (L): mirror image

use RH insert in RH tool holder and
LH insert in LH tool holder

dimensions in mm



Bestellnummer part number	b	t max.	α	R	β	c	Klemmhalter Typ toolholder type			
							K10F	CN45F	AL41F	P18C
R/L ZW40.32116108	3.2	11	61°	0.08	29°	5	●		●	
R/L ZW40.32116115	3.2	11	61°	0.15	29°	5	●		●	R/L HW10... R/L HW15... R/L HW20...
R/L ZW40.32116135	3.2	11	61°	0.35	29°	5	●		●	
R/L ZW40.32116175	3.2	11	61°	0.75	29°	5	●		●	

Weitere HM Sorten können Sie in der Sorten-
übersicht im Kapitel "Technische Hinweise" und
der Preisliste finden.

Bestellbeispiel:
für rechte Ausführung und Sorte
RZW40.32116108/P18C

More carbide grades you can find in the grades
summary in the chapter "technical instructions"
and in the price list.

order-example:
righthand version and grade
RZW40.32116108/P18C

SWISSLINE

Miniatúraußenbearbeitung,
zweischneidig

miniature external machining,
two-cutting edges

Typ ZW41

Wendeschneidplatten,
Kopierdrehen hinten,
mit Spanformer

indexable inserts,
profiling at the back,
with chipformer

Stechtiefe t max. = 11 mm
Stechbreite b = 3.2 mm

depth of groove t max. = 11 mm
width of groove b = 3.2 mm

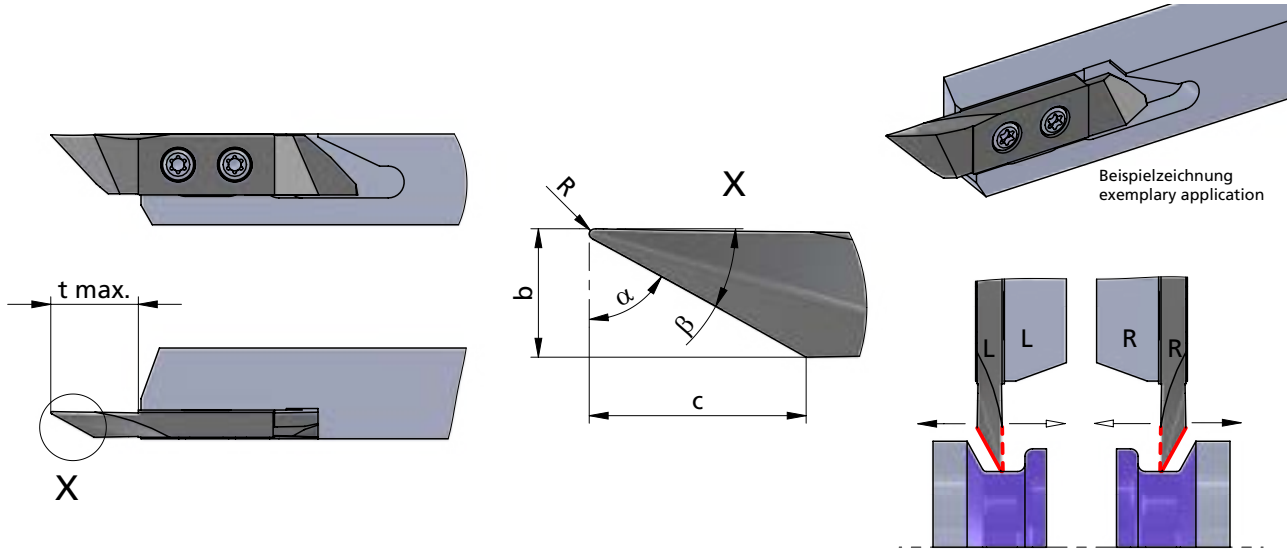

Rechts (R): wie gezeichnet
Links (L): spiegelbildlich

Rechte Schneidpl. in rechtem Halter
Linke Schneidpl. in linkem Halter

Abmessungen in mm

righthand version (R): as shown
lefthand version (L): mirror image

use RH insert in RH tool holder and
LH insert in LH tool holder

dimensions in mm



Bestellnummer part number	b	t max.	α	R	β	c					Klemmhalter Typ toolholder type
							K10F	CN45F	AL41F	P18C	
R/L ZW41.32115515	3.2	11	54°	0.15	35°	4	●				
R/L ZW41.32115535	3.2	11	54°	0.35	35°	4	●				
R/L ZW41.32116108	3.2	11	60°	0.08	29°	5	●		●	R/L HW10,...	
R/L ZW41.32116115	3.2	11	60°	0.15	29°	5	●		●	R/L HW15,...	
R/L ZW41.32116135	3.2	11	60°	0.35	29°	5	●		●	R/L HW20,...	
R/L ZW41.32116175	3.2	11	60°	0.75	29°	5	●		●		

Weitere HM Sorten können Sie in der Sorten-
übersicht im Kapitel "Technische Hinweise" und
der Preisliste finden.

Bestellbeispiel:
für rechte Ausführung und Sorte
RZ41.32115515/P18C

More carbide grades you can find in the grades
summary in the chapter "technical instructions"
and in the price list.

order-example:
righthand version and grade
RZ41.32115515/P18C

SWISSLINE

Miniatúraußenbearbeitung,
zweischneidig

miniature external machining,
two-cutting edges

Typ ZW50

Wendeschneidplatten,
Hintendreher, Wipergeometrie

indexable inserts,
turning at the back, wiper geometry

Stechtiefe t max. = 6 - 8 mm
Stechbreite b = 0.8 - 1.8 mm

depth of groove t max. = 6 - 8 mm
width of groove b = 0.8 - 1.8 mm

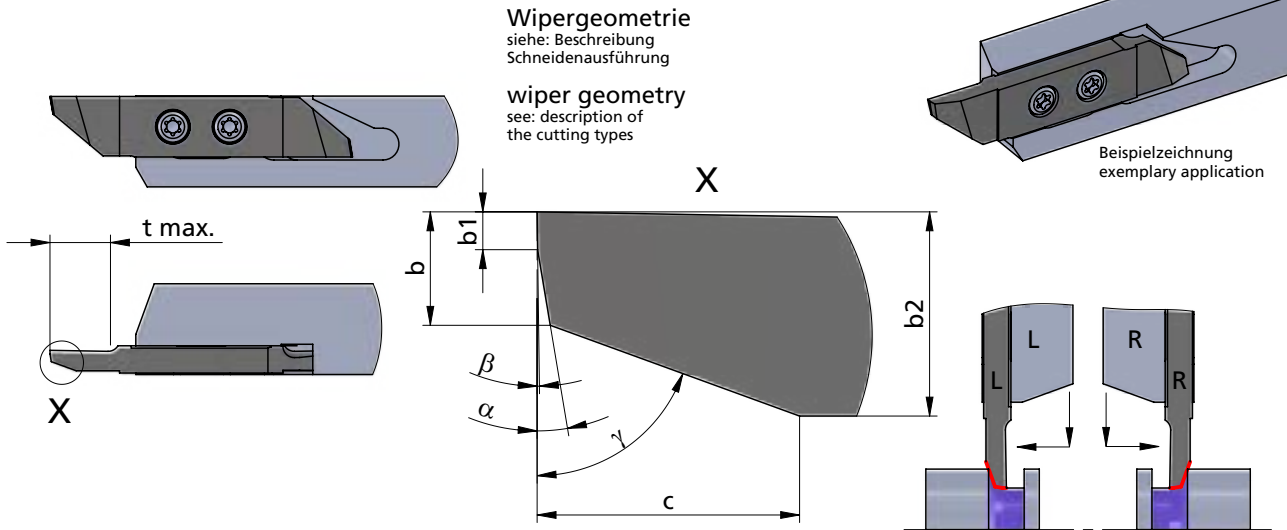

Wipergeometrie
siehe: Beschreibung
Schneidenausführung

wiper geometry
see: description of
the cutting types

Beispielzeichnung
exemplary application

Rechts (R): wie gezeichnet
Links (L): spiegelbildlich

Rechte Schneidpl. in rechtem Halter
Linke Schneidpl. in linkem Halter

Abmessungen in mm

righthand version (R): as shown
lefthand version (L): mirror image

use RH insert in RH tool holder and
LH insert in LH tool holder

dimensions in mm

Bestellnummer part number	b	t max.	α	b1	b2	β	γ	c	K10F	CN45F	AL41F	P18C	Klemmhalter Typ	toolholder type
R/L ZW50.08060800	0.8	6	8°	0.5	2	1°	70°	3	●			●		
R/L ZW50.10060800	1.0	6	8°	0.5	2.2	1°	70°	3	●			●		
R/L ZW50.12080800	1.2	8	8°	0.5	2.4	1°	70°	3	●			●		R/L HW10.... R/L HW15.... R/L HW20....
R/L ZW50.15080800	1.5	8	8°	0.5	2.7	1°	70°	3	●			●		
R/L ZW50.18080800	1.8	8	8°	0.5	3.0	1°	70°	3	●			●		

Weitere HM Sorten können Sie in der Sorten-
übersicht im Kapitel "Technische Hinweise" und
der Preisliste finden.

Bestellbeispiel:
für rechte Ausführung und Sorte
RZW50.08060800/P18C

More carbide grades you can find in the grades
summary in the chapter "technical instructions"
and in the price list.

order-example:
righthand version and grade
RZW50.08060800/P18C

SWISSLINE

Miniatúraußenbearbeitung,
zweischneidig

miniature external machining,
two-cutting edges

Typ ZW51

Wendeschneidplatten,
Kopierdrehen hinten,
mit Spanformer, Wipergeometrie

indexable inserts,
profiling at the back,
with chip former, wiper geometry

Stechtiefe $t \text{ max.} = 6 \text{ mm}$
Stechbreite $b = 0.5 \text{ mm}$

depth of groove $t \text{ max.} = 6 \text{ mm}$
width of groove $b = 0.5 \text{ mm}$



Wipergeometrie

siehe: Beschreibung
Schneidenausführung
wiper geometry
see: description of
the cutting types

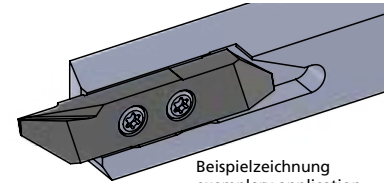
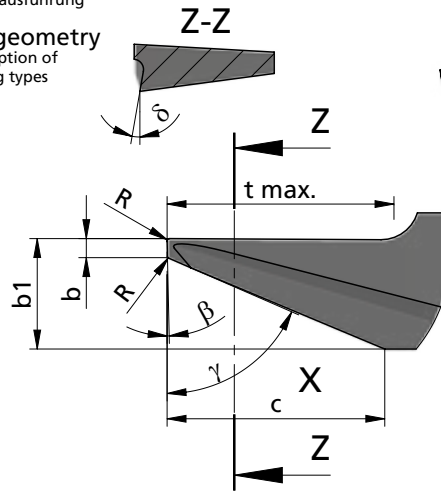
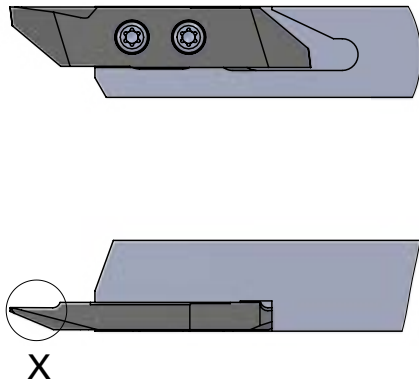

Beispielzeichnung
exemplary application

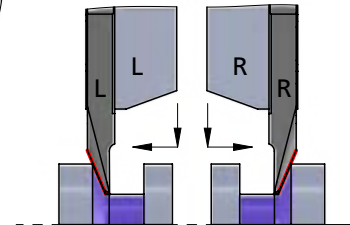

Rechts (R): wie gezeichnet
Links (L): spiegelbildlich

Rechte Schneidpl. in rechtem Halter
Linke Schneidpl. in linkem Halter

Abmessungen in mm

righthand version (R): as shown
lefthand version (L): mirror image

use RH insert in RH tool holder and
LH insert in LH tool holder

dimensions in mm



Bestellnummer part number	b	t max.	γ	R	b1	β	δ	c					Klemmhalter Typ toolholder type
									K10F	CN45F	AL41F	P18C	
R/L ZW51.05067000	0.5	6	70°	0	2.4	1.5°	15°	5	●			●	R/L HW10...
R/L ZW51.05067008	0.5	6	70°	0.08	2.4	1.5°	15°	5	●			●	R/L HW15...
R/L ZW51.05067015	0.5	6	70°	0.15	2.4	1.5°	15°	5	●			●	R/L HW20...

Weitere HM Sorten können Sie in der Sorten-
übersicht im Kapitel "Technische Hinweise" und
der Preisliste finden.

Bestellbeispiel:
für rechte Ausführung und Sorte
RZW51.05067000/P18C

More carbide grades you can find in the grades
summary in the chapter "technical instructions"
and in the price list.

order-example:
righthand version and grade
RZW51.05067000/P18C

SWISSLINE

Miniatöraußenbearbeitung,
zweischneidig

miniature external machining,
two-cutting edges

Typ ZW52

Wendeschneidplatten,
Hintendreher,
mit Spantreppe

indexable inserts,
turning at the back,
with chip breaker

Stechtiefe $t \text{ max.} = 4.5 \text{ mm}$
Stechbreite $b = 0.8 \text{ mm}$

depth of groove $t \text{ max.} = 4.5 \text{ mm}$
width of groove $b = 0.8 \text{ mm}$

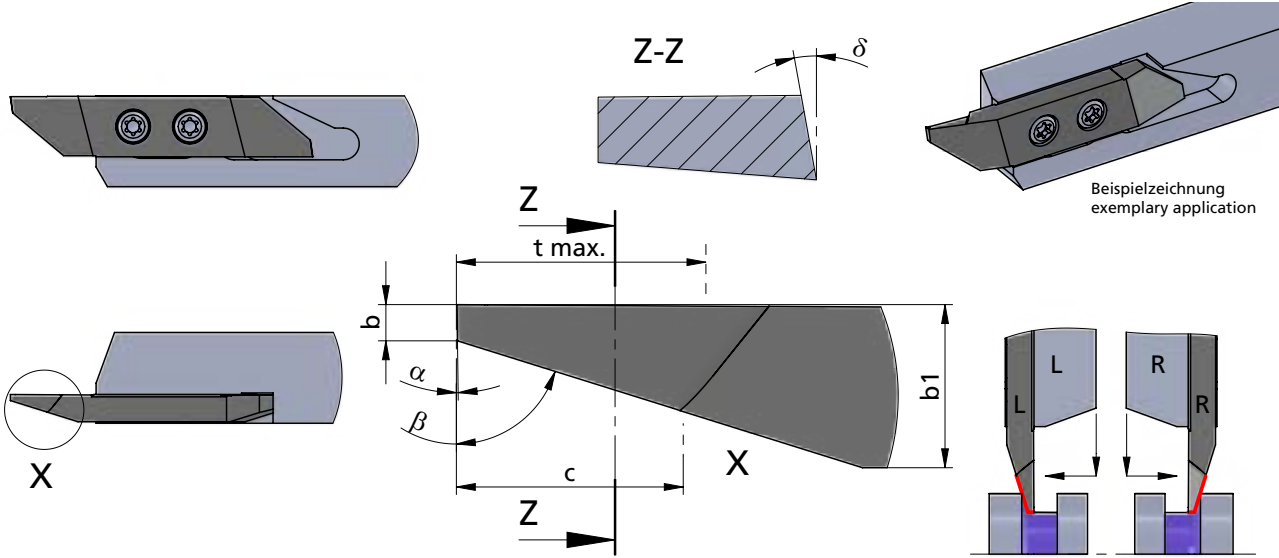

Beispielzeichnung
exemplary application

Rechts (R): wie gezeichnet
Links (L): spiegelbildlich

Rechte Schneidpl. in rechtem Halter
Linke Schneidpl. in linkem Halter

Abmessungen in mm

righthand version (R): as shown
lefthand version (L): mirror image

use RH insert in RH tool holder and
LH insert in LH tool holder

dimensions in mm



Bestellnummer part number	b	t max.	β	b1	α	δ	c	K10F	CN45F	AL41F	P18C	Klemmhalter Typ	toolholder type
												R/L HW10...	R/L HW15...
R/L ZW52.08047000	0.8	4.5	70°	3.2	2°	7°	4	●			●		

Weitere HM Sorten können Sie in der Sorten-
übersicht im Kapitel "Technische Hinweise" und
der Preisliste finden.

Bestellbeispiel:
für rechte Ausführung und Sorte
RZW52.08047000/P18C

More carbide grades you can find in the grades
summary in the chapter "technical instructions"
and in the price list.

order-example:
righthand version and grade
RZW52.08047000/P18C

SWISSLINE

Miniatúraußenbearbeitung,
zweischneidig

miniature external machining,
two-cutting edges

Typ ZW60

Wendeschneidplatten,
Einstechen und Längsdrehen

indexable inserts,
grooving and turning

Stechtiefe t max. = 2.5 - 6 mm
Stechbreite b = 1 - 3 mm

depth of groove t max. = 2.5 - 6 mm
width of groove b = 1 - 3 mm

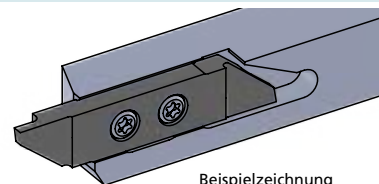
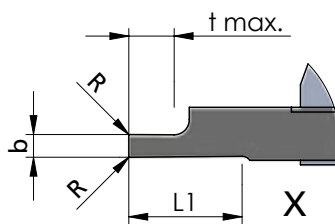
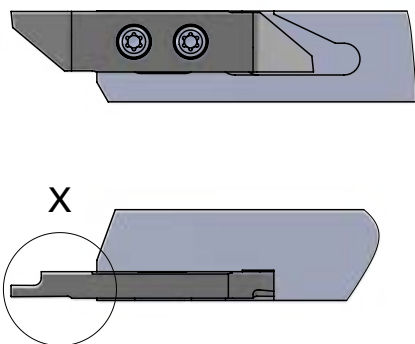

Beispielzeichnung
exemplary application

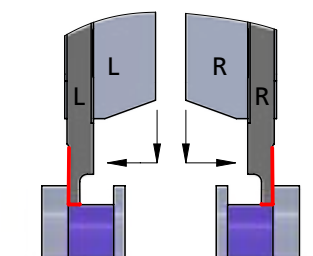

Rechts (R): wie gezeichnet
Links (L): spiegelbildlich

Rechte Schneidpl. in rechtem Halter
Linke Schneidpl. in linkem Halter

Abmessungen in mm

righthand version (R): as shown
lefthand version (L): mirror image

use RH insert in RH tool holder and
LH insert in LH tool holder

dimensions in mm

Bestellnummer part number	b	t max.	R	L1	Klemmhalter Typ toolholder type			
					K10F	CN45F	AL41F	P18C
R/L ZW60.10250005	1.0	2.5	0.05	8	●			●
R/L ZW60.15300005	1.5	3.0	0.05	8	●			●
R/L ZW60.20400005	2.0	4.0	0.05	8	●			●
R/L ZW60.25500005	2.5	5.0	0.05	8	●			●
R/L ZW60.30600005	3.0	6.0	0.05	8	●			●

Weitere HM Sorten können Sie in der Sorten-
übersicht im Kapitel "Technische Hinweise" und
der Preisliste finden.

Bestellbeispiel:
für rechte Ausführung und Sorte
RZW60.10250005/P18C

More carbide grades you can find in the grades
summary in the chapter "technical instructions"
and in the price list.

order-example:
righthand version and grade
RZW60.10250005/P18C



SWISSLINE

Miniatúraußenbearbeitung,
zweischneidig

miniature external machining,
two-cutting edges

Typ ZW61

Wendeschneidplatten,
Einstechen und Längsdrehen,
mit Spantreppe

indexable inserts,
grooving and turning,
with chip breaker

Stechtiefe t max. = 2.5 - 6 mm
Stechbreite b = 0.8 - 3 mm

depth of groove t max. = 2.5 - 6 mm
width of groove b = 0.8 - 3 mm

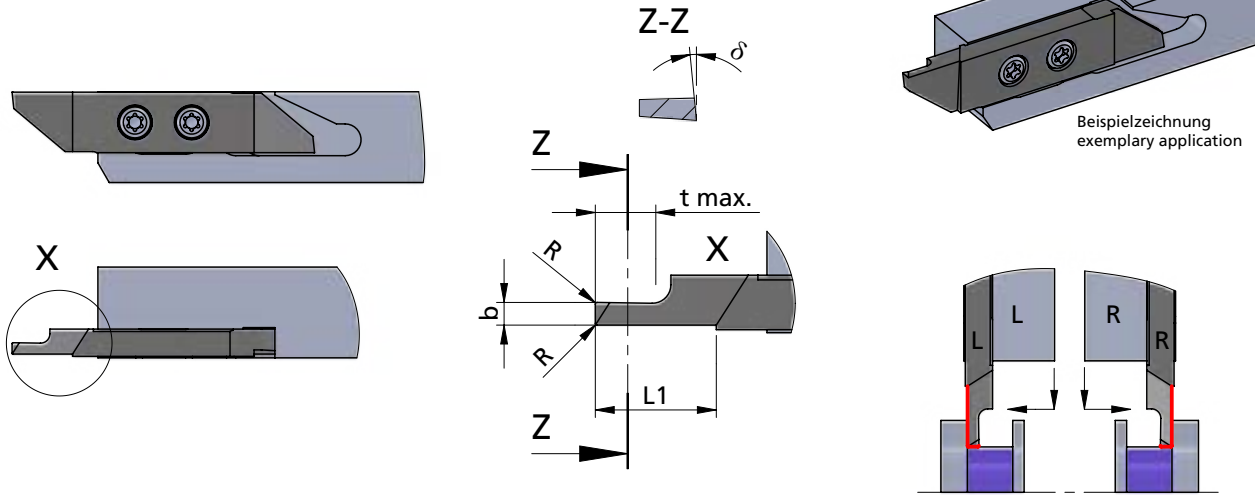

Rechts (R): wie gezeichnet
Links (L): spiegelbildlich

Rechte Schneidpl. in rechtem Halter
Linke Schneidpl. in linkem Halter

Abmessungen in mm

righthand version (R): as shown
lefthand version (L): mirror image

use RH insert in RH tool holder and
LH insert in LH tool holder

dimensions in mm

Bestellnummer part number	b	t max.	R	L1	α	Klemmhalter Typ toolholder type			
						K10F	CN45F	AL41F	P18C
R/L ZW61.08250000	0.8	2.5	0	8	10°	●			
R/L ZW61.10350000	1.0	3.5	0	8	10°	●			
R/L ZW61.15400000	1.5	4.0	0	8	10°	●			
R/L ZW61.15400008	1.5	4.0	0.08	8	10°	●			
R/L ZW61.20500000	2.0	5.0	0	8	10°	●			
R/L ZW61.20500008	2.0	5.0	0.08	8	10°	●			
R/L ZW61.20500015	2.0	5.0	0.15	8	10°	●			R/L HW10... R/L HW15... R/L HW20...
R/L ZW61.25600000	2.5	6.0	0	8	10°	●			
R/L ZW61.25600008	2.5	6.0	0.08	8	10°	●			
R/L ZW61.25600015	2.5	6.0	0.15	8	10°	●			
R/L ZW61.30600000	3.0	6.0	0	8	10°	●			
R/L ZW61.30600008	3.0	6.0	0.08	8	10°	●			
R/L ZW61.30600015	3.0	6.0	0.15	8	10°	●			

Weitere HM Sorten können Sie in der Sorten-
übersicht im Kapitel "Technische Hinweise" und
der Preisliste finden.

Bestellbeispiel:
für rechte Ausführung und Sorte
RZW61.08250000/P18C

More carbide grades you can find in the grades
summary in the chapter "technical instructions"
and in the price list.

order-example:
righthand version and grade
RZW61.08250000/P18C

SWISSLINE

Miniatöraußenbearbeitung,
zweischneidig

miniature external machining,
two-cutting edges

Typ ZW70

Wendeschneidplatten,
Stechdrehen,
Vollradius mit Spantreppe

indexable inserts,
grooving,
full radius with chip breaker

Stechtiefe t max. = 2 - 16 mm
Stechbreite b = 0.5 - 3 mm

depth of groove t max. = 2 - 16 mm
width of groove b = 0.5 - 3 mm

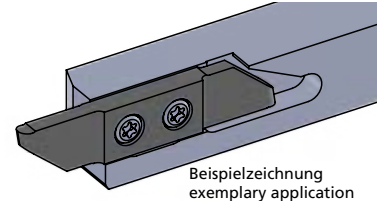
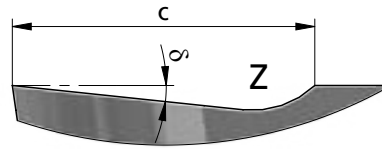
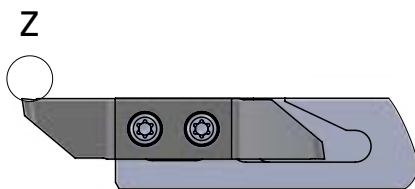

Beispielzeichnung
exemplary application

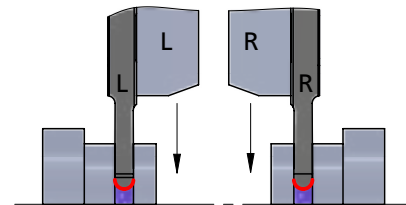
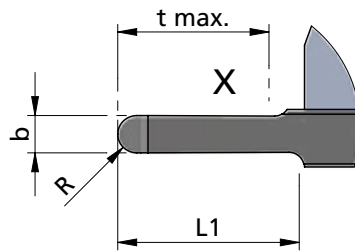
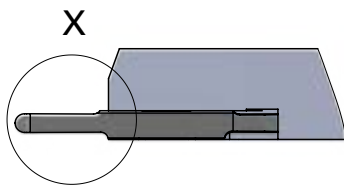

Rechts (R): wie gezeichnet
Links (L): spiegelbildlich

Rechte Schneidpl. in rechtem Halter
Linke Schneidpl. in linkem Halter

Abmessungen in mm

righthand version (R): as shown
lefthand version (L): mirror image

use RH insert in RH tool holder and
LH insert in LH tool holder

dimensions in mm



Bestellnummer part number	b	R	t max.	L1	\varnothing	c					Klemmhalter Typ toolholder type
							K10F	CN45F	AL41F	P18C	
R/L ZW70.0502020	0.5	0.25	2.0	12	6°	2	●			●	R/L HW10... R/L HW15... R/L HW20...
R/L ZW70.1005025	1.0	0.50	2.5	12	6°	2	●			●	
R/L ZW70.1206025	1.2	0.60	2.5	12	6°	2	●			●	
R/L ZW70.1507030	1.5	0.75	3.0	12	6°	2	●			●	
R/L ZW70.1608030	1.6	0.80	3.0	12	6°	2	●			●	
R/L ZW70.2010100	2.0	1.00	10	12	6°	2	●			●	
R/L ZW70.3015100	3.0	1.50	10	12	6°	2	●			●	
R/L ZW70.3015160	3.0	1.50	16	17	6°	2	●			●	

Weitere HM Sorten können Sie in der Sorten-
übersicht im Kapitel "Technische Hinweise" und
der Preisliste finden.

Bestellbeispiel:
für rechte Ausführung und Sorte
RZW70.0502020/P18C

More carbide grades you can find in the grades
summary in the chapter "technical instructions"
and in the price list.

order-example:
righthand version and grade
RZW70.0502020/P18C

SWISSLINE

Miniatúraußenbearbeitung,
zweischneidig

miniature external machining,
two-cutting edges

Typ ZW90

Wendeschneidplatten,
Gewindedrehen,
Vollprofil, 60°

indexable inserts,
threading,
full profile, 60°

Gewinde M1 - M4.5
Steigung P = 0.25 - 0.75

thread M1 - M4.5
pitch P = 0.25 - 0.75

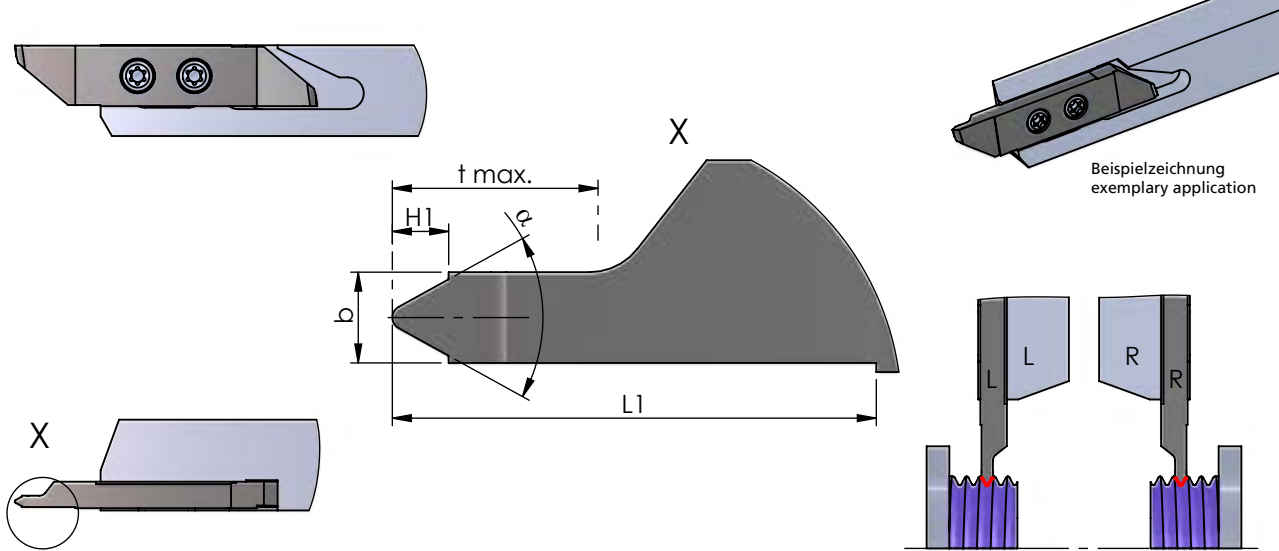

Rechts (R): wie gezeichnet
Links (L): spiegelbildlich

Rechte Schneidpl. in rechtem Halter
Linke Schneidpl. in linkem Halter

Abmessungen in mm

righthand version (R): as shown
lefthand version (L): mirror image

use RH insert in RH tool holder and
LH insert in LH tool holder

dimensions in mm

Bestellnummer part number	Gewindegröße thread size	Steigung P pitch P	α	t max.	H1	b	L1	K10F	CN45F	AL41F	P18C	Klemmhalter Typ toolholder type
R/L ZW90.VP60025	M1 / M1.2	0.25	60°	0	0.140	0.29	8	●			●	R/L HW10... R/L HW15... R/L HW20...
R/L ZW90.VP60030	M1.4	0.30	60°	0	0.168	0.35	8	●			●	
R/L ZW90.VP60035	M1.6 / M1.8	0.35	60°	0	0.215	0.40	8	●			●	
R/L ZW90.VP60040	M2	0.4	60°	0	0.245	0.46	8	●			●	
R/L ZW90.VP60045	M2.2 / M2.5	0.45	60°	0	0.276	0.52	8	●			●	
R/L ZW90.VP60050	M3	0.5	60°	1.3	0.307	0.56	8	●			●	
R/L ZW90.VP60060	M3.5	0.6	60°	1.5	0.368	0.66	8	●			●	
R/L ZW90.VP60070	M4	0.7	60°	1.8	0.429	0.78	8	●			●	
R/L ZW90.VP60075	M4.5	0.75	60°	1.9	0.460	0.82	8	●			●	

Weitere HM Sorten können Sie in der Sortenübersicht im Kapitel "Technische Hinweise" und der Preisliste finden.

Bestellbeispiel:
für rechte Ausführung und Sorte
RZW90.VP60025/P18C

More carbide grades you can find in the grades summary in the chapter "technical instructions" and in the price list.

order-example:
righthand version and grade
RZW90.VP60025/P18C

SWISSLINE

Miniatúraußenbearbeitung,
zweischneidig

miniature external machining,
two-cutting edges

Typ ZW90

Wendeschneidplatten,
Gewindedrehen,
Vollprofil, 60°

indexable inserts,
threading,
full profile, 60°

Gewinde M5 - M27
Steigung P = 0.8 - 3

thread M5 - M27
pitch P = 0.8 - 3

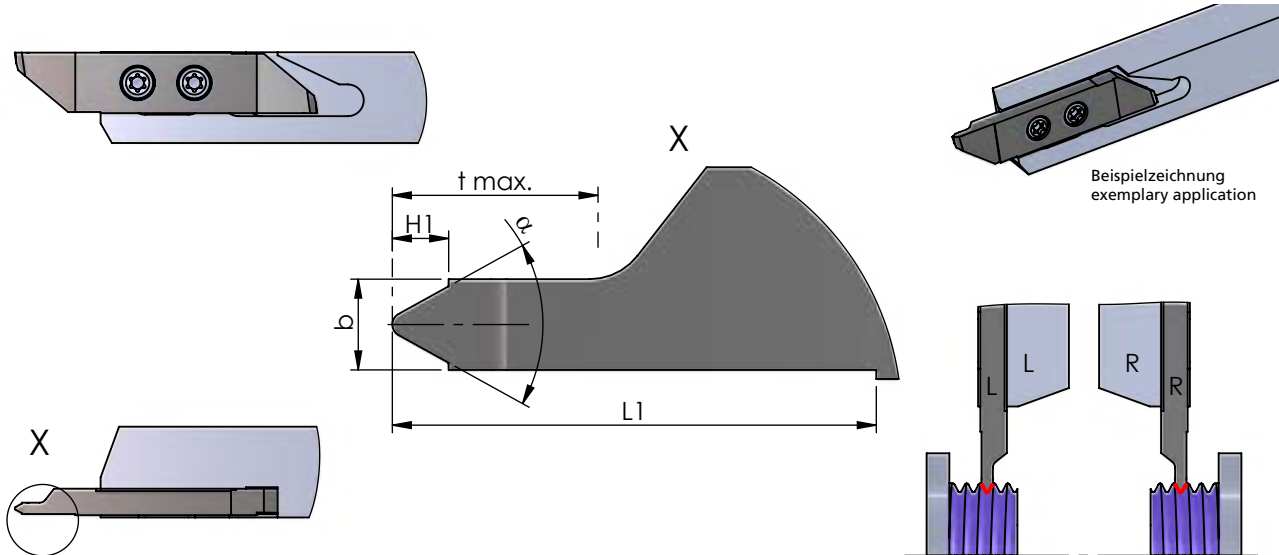

Rechts (R): wie gezeichnet
Links (L): spiegelbildlich

Rechte Schneidpl. in rechtem Halter
Linke Schneidpl. in linkem Halter

Abmessungen in mm

righthand version (R): as shown
lefthand version (L): mirror image

use RH insert in RH tool holder and
LH insert in LH tool holder

dimensions in mm



Bestellnummer part number	Gewindegröße thread size	Steigung P pitch P	α	t max.	H1	b	L1	K10F	CN45F	AL41F	P18C	Klemmhalter Typ	toolholder type
												R/L HW10... R/L HW15... R/L HW20...	
R/L ZW90.VP60080	M5	0.8	60°	2.0	0.491	0.88	8	●			●	R/L HW10... R/L HW15... R/L HW20...	
R/L ZW90.VP60100	M6 / M7	1.0	60°	2.5	0.613	1.10	8	●			●		
R/L ZW90.VP60125	M8 / M9	1.25	60°	3.0	0.767	1.38	8	●			●		
R/L ZW90.VP60150	M10 / M11	1.50	60°	3.8	0.920	1.66	8	●			●		
R/L ZW90.VP60175	M12	1.75	60°	4.4	1.074	1.92	8	●			●		
R/L ZW90.VP60200	M14 / M16	2.00	60°	5.0	1.227	2.20	8	●			●		
R/L ZW90.VP60250	M18 / M20 / M22	2.50	60°	5.0	1.534	2.76	8	●			●		
R/L ZW90.VP60300	M24 / M27	3.00	60°	5.0	1.840	3.30	8	●			●		

Weitere HM Sorten können Sie in der Sortenübersicht im Kapitel "Technische Hinweise" und der Preisliste finden.

Bestellbeispiel:
für rechte Ausführung und Sorte
RZW90.VP60080/P18C

More carbide grades you can find in the grades summary in the chapter "technical instructions" and in the price list.

order-example:
righthand version and grade
RZW90.VP60080/P18C

SWISSLINE

Miniatöraußenbearbeitung,
zweischneidig

miniature external machining,
two-cutting edges

Typ ZW90

Wendeschneidplatten,
Gewindedrehen,
Whitworth, Vollprofil, 55°

indexable inserts,
threading,
Whitworth, full profile, 55°

Steigung P = 11 - 28 Gang / Zoll

pitch P = 11 - 28 threads / inch

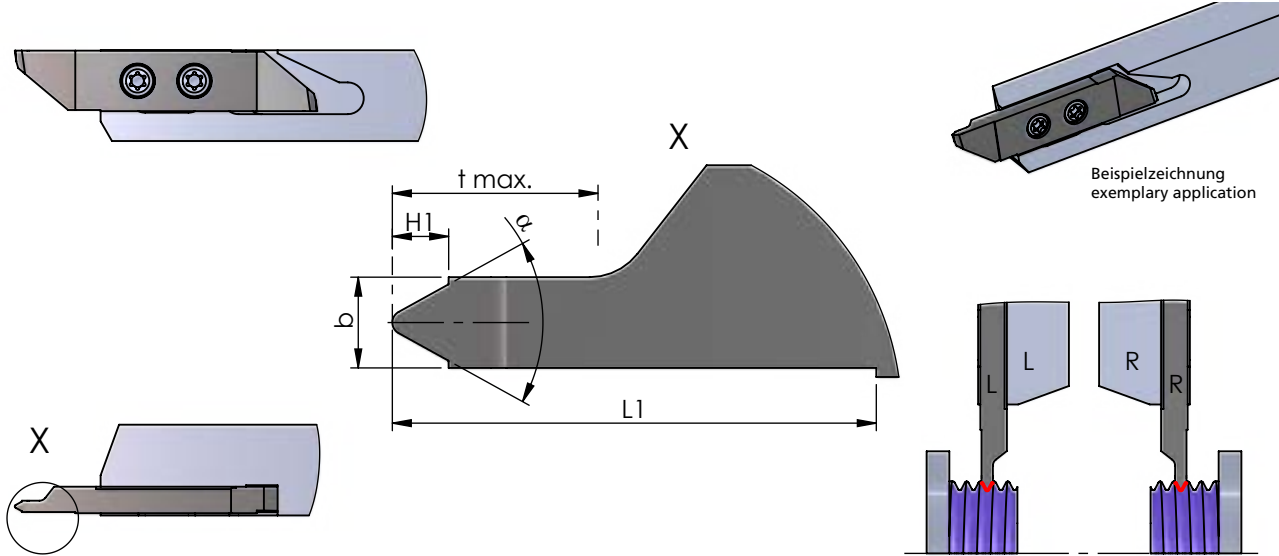

Rechts (R): wie gezeichnet
Links (L): spiegelbildlich

Rechte Schneidpl. in rechtem Halter
Linke Schneidpl. in linkem Halter

Abmessungen in mm

righthand version (R): as shown
lefthand version (L): mirror image

use RH insert in RH tool holder and
LH insert in LH tool holder

dimensions in mm

Bestellnummer part number	Gang / Zoll threads / inch	Steigung P pitch P	α	t max.	H1	b	L1	Klemmhalter Typ toolholder type					
								K10F	CN45F	AL41F	P18C		
R/L ZW90.VP55.11	11	2.309	55°	5.0	1.479	2.54	8						
R/L ZW90.VP55.14	14	1.814	55°	4.5	1.162	2.00	8						R/L HW10.... R/L HW15.... R/L HW20....
R/L ZW90.VP55.19	19	1.337	55°	3.3	0.856	1.48	8						
R/L ZW90.VP55.28	28	0.907	55°	2.3	0.581	1.00	8						

Weitere HM Sorten können Sie in der Sorten-
übersicht im Kapitel "Technische Hinweise" und
der Preisliste finden.

Bestellbeispiel:
für rechte Ausführung und Sorte
RZW90.VP55.11/P18C

More carbide grades you can find in the grades
summary in the chapter "technical instructions"
and in the price list.

order-example:
righthand version and grade
RZW90.VP55.11/P18C

SWISSLINE

Miniatúraußenbearbeitung,
zweischneidig

miniature external machining,
two-cutting edges

Typ ZW94

Wendeschneidplatten,
Gewindedrehen,
Teilprofil, 55° / 60°

indexable inserts,
threading,
partial profile, 55° / 60°

Steigung P = 0.25 - 2

pitch P = 0.25 - 2

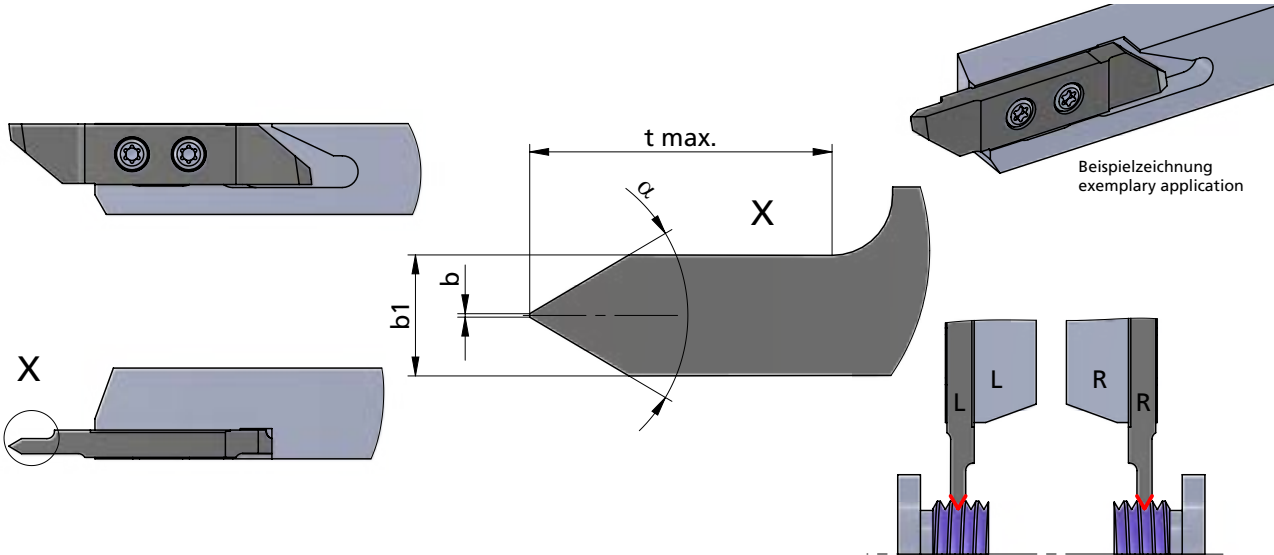

Rechts (R): wie gezeichnet
Links (L): spiegelbildlich

Rechte Schneidpl. in rechtem Halter
Linke Schneidpl. in linkem Halter

Abmessungen in mm

righthand version (R): as shown
lefthand version (L): mirror image

use RH insert in RH tool holder and
LH insert in LH tool holder

dimensions in mm



Bestellnummer part number	Steigung P pitch P	α	t max.	b	b1	Klemmhalter Typ toolholder type			
						K10F	CN45F	AL41F	P18C
R/L ZW94.TP5506	0.25 - 2	55°	6	0.035	2	●		●	
R/L ZW94.TP5510	0.25 - 2	55°	10	0.035	3	●		●	
R/L ZW94.TP6006	0.25 - 2	60°	6	0.035	2	●		●	R/L HW10... R/L HW15... R/L HW20...
R/L ZW94.TP6010	0.25 - 2	60°	10	0.035	3	●		●	

Weitere HM Sorten können Sie in der Sortenübersicht im Kapitel "Technische Hinweise" und der Preisliste finden.

Bestellbeispiel:
für rechte Ausführung und Sorte
RZW94.TP5506/P18C

More carbide grades you can find in the grades summary in the chapter "technical instructions" and in the price list.

order-example:
righthand version and grade
RZW94.TP5506/P18C

SWISSLINE

Miniatúraußenbearbeitung,
zweischneidig

miniature external machining,
two-cutting edges

Impressionen

impressions



SWISSLINE

Miniaturaußenbearbeitung,
zweischneidig

miniature external machining,
two-cutting edges

Technische Hinweise

Beschreibung der Schneidenausführungen

Technical instructions,
Description of the cutting types

Bezeichnung Schneide

Das Merkmal "vorne" und "hinten" bezieht sich nicht auf die Richtung der Bearbeitung, sondern zeigt an, auf welcher Seite eine senkrechte Flanke erstellt werden kann mit der entsprechenden Schneide.

Description cutting edge

The description "front" or "back" means not the cutting direction, this shows the side which can produce an upright flank.

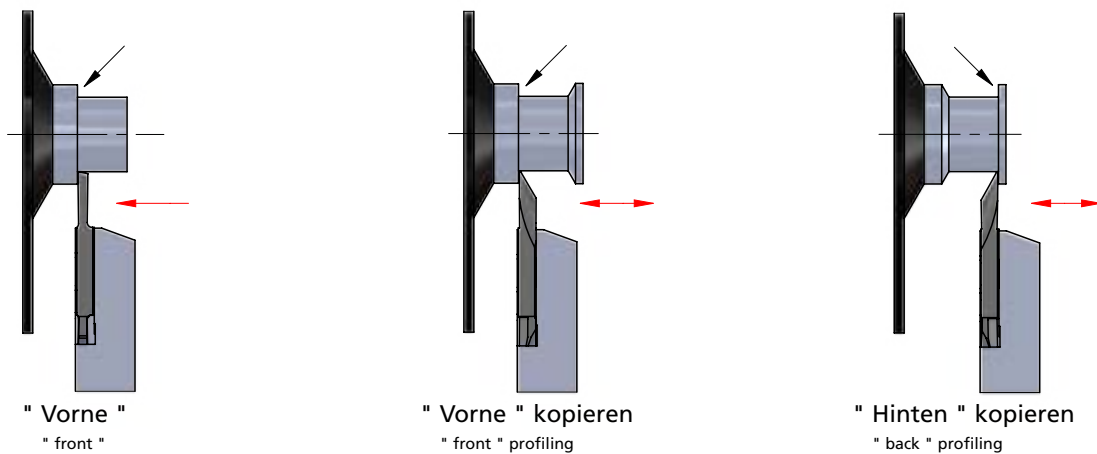

Wiper-Geometrie

Durch Einsatz einer Schneide mit Wipergeometrie kann der Vorschub bis zum doppelten im Gegensatz zu einer Schneide mit normalem Eckenradius erhöht werden.

Durch die spezielle Geometrie der Schneide kann eine geringere Rautiefe trotz höherem Vorschub erreicht werden.

Wiper geometry

By using the insert with wiper geometry the feed rate can be increased up to double time in contrast to an insert with standard radius.

The special geometry improves the surface quality by using a higher feed rate.

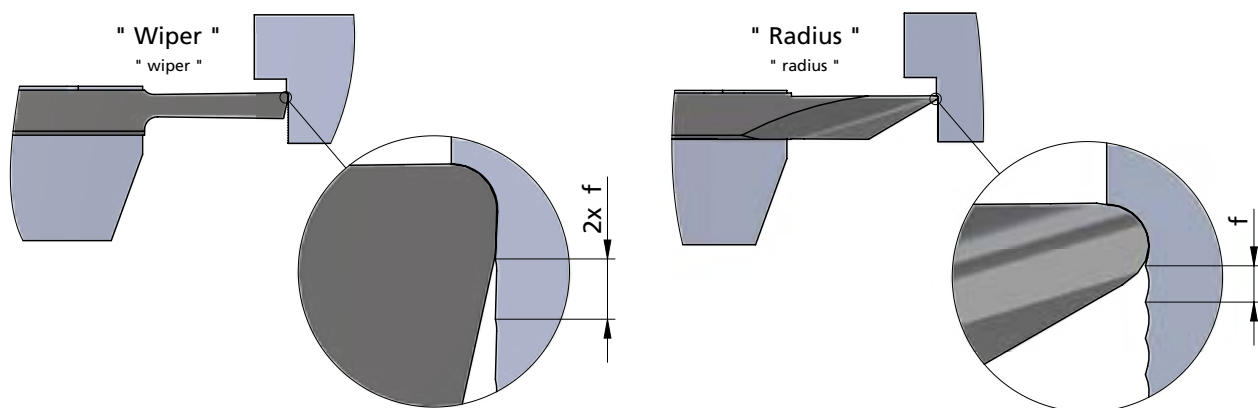

SWISSLINE

Miniaturaußenbearbeitung,
zweischneidig

miniature external machining,
two-cutting edges

Technische Hinweise

Allgemeine Informationen zum
Gewindeschneiden

Technical instructions,
General informations about threading

Empfohlene Anzahl der Schnitte

Die Anzahl der Schnitte ist nur ein Richtwert für das Gewindedrehen. Um eine möglichst lange Standzeit der Schneide zu erreichen beachten Sie bitte die Erklärungen für die Zustellung.
Leerschnitte zum Fertigschneiden sind in dieser Tabelle nicht berücksichtigt.

Recommended number of passes

The number of passes is only a recommendation for threading. To reach a good tool life you have to mention the explanation for the infeed.
Finishing passes are not considered in that chart.

	Stahl (Festigkeit N/mm ²) Steel (N/mm ² tensile strength)					rostfreier Stahl stainless steel	Guss cast iron	Alumini- um alumi- um
	400-500	500-700	700-850	850-1150	>1150			
V m/min	160	140	120	90	70	90	100	300
Steigung P Pitch P		Anzahl der Schnitte number of passes						
mm	Gg/" TPI							
0,25 - 0,35	80/72	3 - 5	3 - 5	3 - 5	3 - 5	3 - 5	3 - 5	3 - 5
0,4	64	3 - 5	3 - 5	4 - 6	4 - 6	4 - 6	4 - 6	3 - 6
0,45	56	3 - 6	3 - 5	4 - 6	5 - 7	5 - 7	5 - 7	4 - 6
0,5	48/44	5 - 8	5 - 8	6 - 9	7 - 10	7 - 10	7 - 10	6 - 9
0,75	40/36	7 - 9	7 - 9	8 - 10	9 - 11	9 - 11	9 - 11	8 - 10
0,8	32	7 - 10	7 - 10	8 - 11	10 - 12	10 - 12	10 - 12	8 - 11
1	28/24	8 - 12	9 - 13	10 - 14	11 - 15	12 - 15	12 - 15	10 - 14
1,25	20/19	10 - 15	11 - 16	12 - 17	14 - 18	15 - 18	15 - 18	12 - 17
1,5	18/16	11 - 18	12 - 19	15 - 20	16 - 21	18 - 22	18 - 22	15 - 20
1,75	14	12 - 20	13 - 21	15 - 22	18 - 23	20 - 24	20 - 24	15 - 22
2-2,5	13/11	15 - 24	16 - 25	18 - 26	20 - 27	22 - 28	22 - 28	18 - 26



SWISSLINE

Miniaturaußenbearbeitung,
zweischneidig

miniature external machining,
two-cutting edges

Technische Hinweise

Allgemeine Informationen zum
Gewindeschneiden

Technical instructions,
General informations about threading

Vorschubrichtung

Mit jedem Schneideinsatz für das Gewindedrehen kann sowohl ein Rechts- wie auch ein Linksgewinde geschnitten werden. Hierbei ist folgende Vorschubrichtung zu beachten:

Feed direction

Every insert can be used for right- and lefthand thread. You only have to consider the following feed direction:



Zustellungsvarianten

Radiale Zustellung	wechselnde Flankenzustellung	einseitige Flankenzustellung
Die meist verwendete Methode um Gewinde herzustellen. Beide Schneiden sind gleichzeitig im Eingriff.	Die Schneiden werden wechselnd eingesetzt.	Nur eine Schneide wird für die komplette Gewindeerstellung eingesetzt.
Problematische Spanbildung, dadurch hohe Schnittkräfte und Verschleiß am Werkzeug und Bauteil.	Reduzierung des Schnittdrucks, höhere Standzeit und bessere Spanbildung.	Reduzierung des Schnittdrucks und bessere Spanbildung, aber einseitige Abnutzung des Werkzeugs.

Infeed possibilities

Radial infeed	alternating flank infeed	flank infeed
The most used method for threading, both sides are at the same time in process.	The flanks are alternating used.	Only one cutting edge is used for the complete thread.
Problematic chip forming, high cutting force and weariness at insert and work piece.	Reduced cutting force, higher tool life and chip forming.	Reduced cutting force and better chip forming, but one-sided weariness.

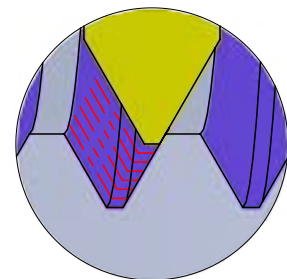
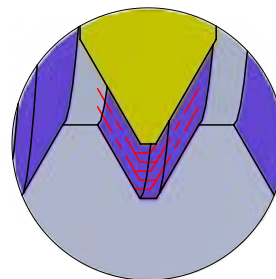
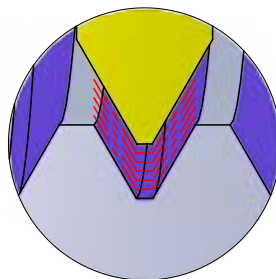

SWISSLINE

Miniaturaußenbearbeitung,
zweischneidig

miniature external machining,
two-cutting edges

Technische Hinweise

Hartmetallsorten und Beschichtungen

Technical instructions,
carbide grades and coatings

K10F

Universell einsetzbares Feinkornhartmetall mit guter Verschleißfestigkeit. Unbeschichtet geeignet für Anwendungen mit niedrigen und mittleren Schnittgeschwindigkeiten, sowie die Bearbeitung von NE-Metallen.

All purpose micrograin carbide with good abrasion resistance. Uncoated for applications with low or medium cutting speeds and machining of non-ferrous materials.

P04C

Optimierte, sehr universell einsetzbare TIALN-Beschichtung mit hoher Temperaturbeständigkeit bei hoher Härte. Sehr gut geeignet auch für NE-Metalle.

Optimized TIALN coating - very universal with a high resistance to high temperature and hardness. Very suitable also for non-ferrous metals.

AL41F

Sehr universell einsetzbare TIALN-Beschichtung mit hoher Temperaturbeständigkeit bei hoher Härte. Sehr gut geeignet auch für NE-Metalle.

TIALN coating - very universal with a high resistance to high temperature and hardness. Very suitable also for non-ferrous metals.



CN45F

Universell einsetzbare PVD-TIN-Beschichtung. Diese Allround-Sorte ist für niedrige und mittlere Schnittgeschwindigkeiten mit Einschränkung bei NE-Metallen.

PVD-TIN coating - all purpose, all around grade is suitable for low and medium cutting speed with restrictions on non-ferrous materials.

P18C

Universell einsetzbare Hochleistungsschicht mit hoher Oxidationsbeständigkeit, Verschleißfestigkeit und Warmhärte.

Very universal high performance coating with high oxidation resistance, wear resistance and hot hardness resistance.

P07C

Beschichtung für die Bearbeitung von Titan, Edelstahl und Molybdän.

Coating to machine titanium, stainless steel and molybdenum.

SWISSLINE

Miniaturaußenbearbeitung,
zweischneidig

miniature external machining,
two-cutting edges

Technische Hinweise

Hartmetallsorten und Beschichtungen

Technical instructions,
carbide grades and coatings

XC2A

Beschichtung mit einer exzellenten Warmhärte, Oxidationsbeständigkeit und thermischen Isolationsfähigkeit. Ideal für Hartzerspanung >60HRC

Coating with excellent hot hardness, high oxidation resistance and thermal insulation capacity. Ideal for hard machining >60 HRC.

P03C

Beschichtung für die Bearbeitung von schwer zerspanbaren Materialien. Sehr gut auch für die Trockenbearbeitung geeignet.

Coating for materials which are difficult to machine. Perfect to use for dry machining.

PD2F

Beschichtung für den universellen Einsatz bei niedrigen und mittleren Schnittgeschwindigkeiten.

Coating for universal use with medium and low speed.



NEME

Beschichtung für die Bearbeitung von Aluminium, Al-Legierungen, NE-Metallen und Kompositwerkstoffen.

Coating for machining aluminium, Al alloys, non-ferrous metals and composite materials.

SWISSLINE

Miniatöraußenbearbeitung,
zweischneidig

miniature external machining,
two-cutting edges

Technische Hinweise

Schnittdatenempfehlung:
metrisch

Schnittgeschwindigkeit: V_c (m/min)
Vorschub: f (mm/U)

Technical instructions,
speed and feed recommendation:
metric

cutting speed: V_c (m/min)
feed: f (mm/rev)

Werkstoffgruppe material group		Zusammensetzung composition		(Zug-)Festigkeit tensile strength	
ISO	Beschreibung / description	Gefüge / structure	Wärmebehandlung / heat treatment	Psi / N/mm ² (Rm) / HB / HRC	
P	Unlegierter Stahl unalloyed steel	ca.Japp. 0,15 % C	geglüht / annealed	61000 Psi / 420 N/mm ² / 125 HB	
		ca.Japp. 0,45 % C	geglüht / annealed	93000 Psi / 640 N/mm ² / 190 HB	
			vergütet / tempered	122000 Psi / 840 N/mm ² / 250 HB	
		ca.Japp. 0,75 % C	geglüht / annealed	132000 Psi / 910 N/mm ² / 270 HB	
	Niedriglegierter Stahl low alloyed steel		vergütet / tempered	146500 Psi / 1010 N/mm ² / 300 HB	
			geglüht / annealed	88500 Psi / 610 N/mm ² / 180 HB	
			vergütet / tempered	135000 Psi / 930 N/mm ² / 275 HB	
			vergütet / tempered	146500 Psi / 1010 N/mm ² / 300 HB	
	Hochlegierter (Werkzeug)-Stahl highly alloyed steel		geglüht / annealed	174000 Psi / 1200 N/mm ² / 375 HB	
			geglüht / annealed	99000 Psi / 680 N/mm ² / 200 HB	
		gehärtet & angelassen / hardened & tempered	160000 Psi / 1100 N/mm ² / 300 HB		
Nichtrostender Stahl stainless steel		gehärtet & angelassen / hardened & tempered	189000 Psi / 1300 N/mm ² / 400 HB		
		ferritisch, martensitisch / ferritic, martensitic	geglüht / annealed	99000 Psi / 680 N/mm ² / 200 HB	
M	Nichtrostender Stahl stainless steel		martensitisch / martensitic	vergütet / tempered	117500 Psi / 810 N/mm ² / 250 HB
			austenitisch / austenitic	abgeschreckt / quenched	88500 Psi / 610 N/mm ² / 200 HB
			austenitisch / austenitic	vergütet / tempered	300 HB
			austenitisch, ferritisch / ferritic, martensitic (Duplex)		113000 Psi / 780 N/mm ² / 230 HB
K	Grauguss cast iron		perlitisch, ferritisch / pearlitic, ferritic	51000 Psi / 350 N/mm ² / 180 HB	
			perlitisch (martensitisch) / pearlitic (martensitic)	72500 Psi / 500 N/mm ² / 260 HB	
	Gusseisen mit Kugelgraphit cast iron with nodular graphite		ferritisch / ferritic	72500 Psi / 500 N/mm ² / 160 HB	
			perlitisch / pearlitic	122500 Psi / 845 N/mm ² / 250 HB	
			ferritisch / ferritic	63800 Psi / 440 N/mm ² / 130 HB	
Temperguss malleable iron		perlitisch / pearlitic	113000 Psi / 780 N/mm ² / 230 HB		
N	Aluminium - Knetlegierungen wrought aluminum alloys		nicht aushärtbar / uncurable	60 HB	
			aushärtbar / curable	ausgehärtet / cured	49000 Psi / 340 N/mm ² / 100 HB
			≤ 12% Si, nicht aushärtbar / uncurable		36250 Psi / 250 N/mm ² / 75 HB
	Aluminium - Gusslegierungen cast aluminum alloys		≤ 12% Si, aushärtbar / curable	ausgehärtet / cured	43500 Psi / 300 N/mm ² / 90 HB
			> 12% Si, nicht aushärtbar / uncurable		63800 Psi / 440 N/mm ² / 130 HB
Kupfer und Kupferlegierungen (Bronze / Messing) copper and copper alloys (bronze / brass)		PB > 1 %, Automatenlegierungen / free cutting alloys		54500 Psi / 375 N/mm ² / 110 HB	
		CuZn, CuSnZn		43500 Psi / 300 N/mm ² / 90 HB	
		CuSn, bleifrei & Elektrolytisch / lead free & electrolytic		49000 Psi / 340 N/mm ² / 100 HB	
Magnesium & -Legierungen / Mg-alloys		Magnesium und -Legierungen / and -alloys		70 HB	
S	Warmfeste Legierungen heat-resistant alloys		Fe-Basis / Fe base	geglüht / annealed	99000 Psi / 680 N/mm ² / 200 HB
				ausgehärtet / cured	137750 Psi / 950 N/mm ² / 280 HB
			Ni- oder Co-Basis / Ni- or Co-Base	geglüht / annealed	122000 Psi / 840 N/mm ² / 250 HB
				ausgehärtet / cured	171000 Psi / 1180 N/mm ² / 350 HB
				gegossen / cast	156600 Psi / 1080 N/mm ² / 320 HB
	Titanlegierungen titanium alloys		Reintitan / pure titanium		58000 Psi / 400 N/mm ²
			Alpha- + Beta-Legierungen / -alloys	ausgehärtet / cured	152250 Psi / 1050 N/mm ²
H	Gehärteter Stahl hardened steel		Beta-Legierungen / -alloys	203000 Psi / 1400 N/mm ² / 410 HB	
				gehärtet & angelassen / hardened & tempered	46-55 HRC
				gehärtet & angelassen / hardened & tempered	56-60 HRC
				gehärtet & angelassen / hardened & tempered	61-65 HRC
	Hartguss / chilled cast iron			gehärtet & angelassen / hardened & tempered	66-70 HRC
Gehärtetes Guss / hardened cast iron			gegossen / cast	400 HB	
O	Nichtmetallische Werkstoffe non-metallic materials			gehärtet & angelassen / hardened & tempered	55 HRC
			Kunststoffe, duroplastisch / plastics, duroplastic		≤ 21750 Psi / ≤ 150 N/mm ²
			Kunststoffe, thermoplastisch / plastics, thermoplastic		≤ 14500 Psi / ≤ 100 N/mm ²
			aramidfaserverstärkt / aramid fiber reinforced		≤ 145000 Psi / ≤ 1000 N/mm ²
			glas/kohlefaserverstärkt / glas/carbon fiber reinforced		≤ 145000 Psi / ≤ 1000 N/mm ²
	Graphit / graphite				



Richtige Schnittgeschwindigkeit ist in Abhängigkeit von Dimension und Anwendungssituation zu wählen.
The correct cutting speed must be selected depending on the dimension and application situation.

20 (10 - 50) bevorzugte Wahl / best choice
 20 (10 - 50) bedingt möglich / conditionally possible

20 (10 - 50) empfohlener Startwert recommended starting value (bevorzugter Einsatzbereich) (preferred application area)

Vorschub: feed f: [mm/U] [mm/rev]

Schruppen: roughing: 0.1 - 0.25 mm/U / 0.1 - 0.25 mm/rev

Schlichten: finishing: 0.02 - 0.2 mm/U / 0.02 - 0.2 mm/rev

Feinschlichten: super finishing: 0.005 - 0.12 mm/U / 0.005 - 0.12 mm/rev

SWISSLINE

Miniatöraußenbearbeitung,
zweischneidig

miniature external machining,
two-cutting edges

Technische Hinweise

Schnittdatenempfehlung:

Technical instructions,
speed and feed recommendation:
imperial

cutting speed (SFM): V_c (feet/min)
feed: f (inch/rev)



Werkstoffgruppe material group		Zusammensetzung composition		(Zug-)Festigkeit tensile strength	
ISO	Beschreibung / description	Gefüge / structure	Wärmebehandlung / heat treatment	Psi / N/mm ² (Rm) / HB / HRC	
P	Unlegierter Stahl unalloyed steel	ca.Japp. 0,15 % C	geglüht / annealed	61000 Psi / 420 N/mm ² / 125 HB	
		ca.Japp. 0,45 % C	geglüht / annealed	93000 Psi / 640 N/mm ² / 190 HB	
			vergütet / tempered	122000 Psi / 840 N/mm ² / 250 HB	
		ca.Japp. 0,75 % C	geglüht / annealed	132000 Psi / 910 N/mm ² / 270 HB	
	Niedriglegierter Stahl low alloyed steel			vergütet / tempered	146500 Psi / 1010 N/mm ² / 300 HB
				geglüht / annealed	88500 Psi / 610 N/mm ² / 180 HB
				vergütet / tempered	135000 Psi / 930 N/mm ² / 275 HB
				vergütet / tempered	146500 Psi / 1010 N/mm ² / 300 HB
				vergütet / tempered	174000 Psi / 1200 N/mm ² / 375 HB
				geglüht / annealed	99000 Psi / 680 N/mm ² / 200 HB
Hochlegierter (Werkzeug)-Stahl highly alloyed steel			gehärtet & angelassen / hardened & tempered	160000 Psi / 1100 N/mm ² / 300 HB	
			gehärtet & angelassen / hardened & tempered	189000 Psi / 1300 N/mm ² / 400 HB	
Nichtrostender Stahl stainless steel		ferritisch, martensitisch / ferritic, martensitic	geglüht / annealed	99000 Psi / 680 N/mm ² / 200 HB	
		martensitisch / martensitic	vergütet / tempered	117500 Psi / 810 N/mm ² / 250 HB	
M	Nichtrostender Stahl stainless steel	austenitisch / austenitic	abgeschreckt / quenched	88500 Psi / 610 N/mm ² / 200 HB	
		austenitisch / austenitic	vergütet / tempered	300 HB	
		austenitisch, ferritisch / ferritic, martensitic (Duplex)		113000 Psi / 780 N/mm ² / 230 HB	
K	Grauguss cast iron	perlitisches, ferritisch / pearlitic, ferritic		51000 Psi / 350 N/mm ² / 180 HB	
		perlitisches (martensitisch) / pearlitic (martensitic)		72500 Psi / 500 N/mm ² / 260 HB	
	Gusseisen mit Kugelgraphit cast iron with nodular graphite	ferritisch / ferritic		72500 Psi / 500 N/mm ² / 160 HB	
		perlitisches / pearlitic		122500 Psi / 845 N/mm ² / 250 HB	
		ferritisch / ferritic		63800 Psi / 440 N/mm ² / 130 HB	
Temperguss malleable iron		perlitisches / pearlitic		113000 Psi / 780 N/mm ² / 230 HB	
N	Aluminium - Knetlegierungen wrought aluminum alloys	nicht aushärtbar / uncurable		60 HB	
		aushärtbar / curable	ausgehärtet / cured	49000 Psi / 340 N/mm ² / 100 HB	
	Aluminium - Gusslegierungen cast aluminum alloys	≤ 12% Si, nicht aushärtbar / uncurable		36250 Psi / 250 N/mm ² / 75 HB	
		≤ 12% Si, aushärtbar / curable	ausgehärtet / cured	43500 Psi / 300 N/mm ² / 90 HB	
		> 12% Si, nicht aushärtbar / uncurable		63800 Psi / 440 N/mm ² / 130 HB	
	Kupfer und Kupferlegierungen (Bronze / Messing) copper and copper alloys (bronze / brass)	PB > 1 %, Automatenlegierungen / free cutting alloys		54500 Psi / 375 N/mm ² / 110 HB	
CuZn, CuSnZn			43500 Psi / 300 N/mm ² / 90 HB		
	CuSn, bleifrei & Elektrolytisch / lead free & electrolytic		49000 Psi / 340 N/mm ² / 100 HB		
	Magnesium- & -Legierungen / Mg-alloys	Magnesium und -Legierungen / and -alloys		70 HB	
S	Warmfeste Legierungen heat-resistant alloys	Fe-Basis / Fe base	geglüht / annealed	99000 Psi / 680 N/mm ² / 200 HB	
			ausgehärtet / cured	137750 Psi / 950 N/mm ² / 280 HB	
		Ni- oder Co-Basis / Ni- or Co-Base	geglüht / annealed	122000 Psi / 840 N/mm ² / 250 HB	
			ausgehärtet / cured	171000 Psi / 1180 N/mm ² / 350 HB	
			gegossen / cast	156600 Psi / 1080 N/mm ² / 320 HB	
	Titanlegierungen titanium alloys	Reintitan / pure titanium		58000 Psi / 400 N/mm ²	
		Alpha- + Beta-Legierungen / -alloys	ausgehärtet / cured	152250 Psi / 1050 N/mm ²	
	Beta-Legierungen / -alloys		203000 Psi / 1400 N/mm ² / 410 HB		
H	Gehärteter Stahl hardened steel		gehärtet & angelassen / hardened & tempered	46-55 HRC	
			gehärtet & angelassen / hardened & tempered	56-60 HRC	
			gehärtet & angelassen / hardened & tempered	61-65 HRC	
			gehärtet & angelassen / hardened & tempered	66-70 HRC	
	Hartguss / chilled cast iron		gegossen / cast	400 HB	
Gehärtetes Guss / hardened cast iron		gehärtet & angelassen / hardened & tempered	55 HRC		
O	Nichtmetallische Werkstoffe non-metallic materials	Kunststoffe, duroplastisch / plastics, duroplastic		≤ 21750 Psi / ≤ 150 N/mm ²	
		Kunststoffe, thermoplastisch / plastics, thermoplastic		≤ 14500 Psi / ≤ 100 N/mm ²	
		aramidfaserverstärkt / aramid fiber reinforced		≤ 145000 Psi / ≤ 1000 N/mm ²	
		glas/kohlefaserverstärkt / glas/carbon fiber reinforced		≤ 145000 Psi / ≤ 1000 N/mm ²	
		Graphit / graphite			

The correct cutting speed must be selected depending on the dimension and application situation.

20 (10 - 50) best choice
20 (10 - 50) conditionally possible

20 (10 - 50) recommended starting value (preferred application area)

feed f: [inch/rev]
roughing: 0.0039 - 0.0098 in/rev
finishing: 0.0008 - 0.0079 in/rev
super finishing: 0.0002 - 0.0047 in/rev



duemmel.de

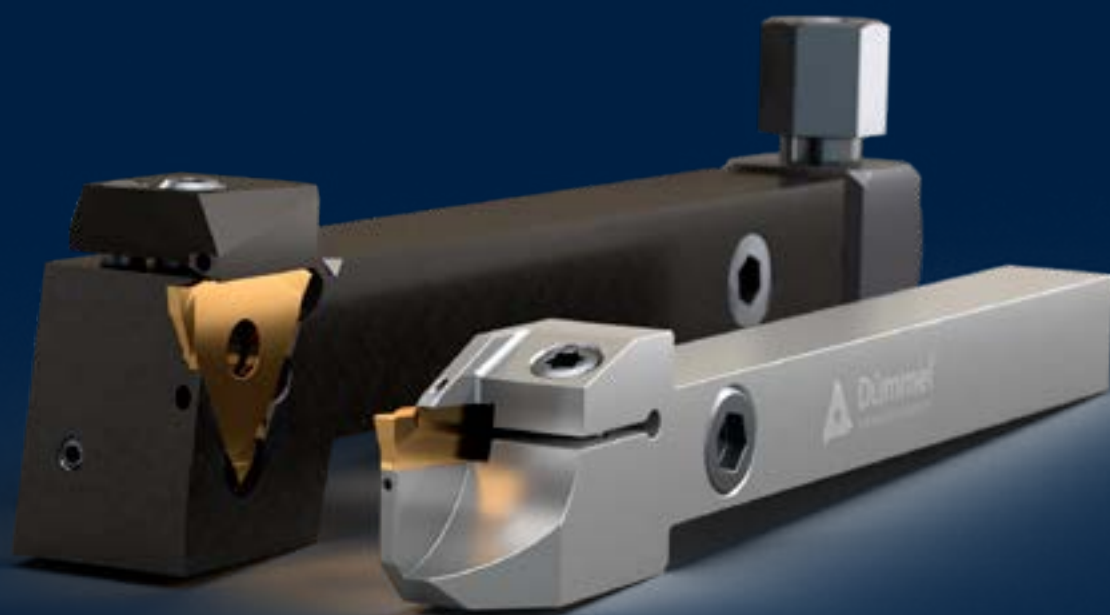

STECHDREH- WERKZEUGE

SYSTEM DED: $S \geq 0.5 \text{ mm}$

SYSTEM D-GROOVING: $b \geq 2.0 \text{ mm}$

SYSTEM DED

Einstecken mit dreischneidigen Wendeplatten

grooving with three-cutting edges indexable inserts

Übersicht

summary

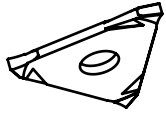

Allgemeine Beschreibung

general instructions

... 9

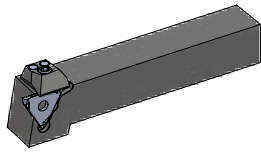

**Klemmhalter
geprägt**

**toolholder
fixed with claw**

**Maße
dimensions
[mm]**

**Seite
page**

Typ .207	Klemmhalter, Außenbearbeitung	toolholder, external application	Spannbereich holding capacity S 0.5 - 6.5 t max. 4 / 6	... 10
Typ .207 ... -IK	Klemmhalter, Außenbearbeitung, innere Kühlmittelzufuhr	toolholder, external application, through coolant	Spannbereich holding capacity S 0.5 - 4.0 t max. 4 / 6	... 12
Typ .0.780	Klemmhalter, Außenbearbeitung	toolholder, external application	Spannbereich holding capacity S 1.4 - 6.5 t max. 8	... 13
Typ .0.782	Klemmhalter, Außenbearbeitung	toolholder, external application	Spannbereich holding capacity S 0.5 - 1.9 t max. 8	... 14
Typ .0.738	Klemmhalter, gekröpft Außenbearbeitung	toolholder, cranked, external application	Spannbereich holding capacity S 0.5 - 6.5 t max. 4 / 6	... 15
Typ .0.618	Klemmhalter 45°, für Eckenfreistiche, Außenbearbeitung	toolholder 45°, for corner reliefs, external application	Spannbereich holding capacity S 1.9 - 6.5	... 16
Typ .0.660	Bohrstange, Innenbearbeitung	grooving boring bar, internal application	Spannbereich holding capacity S 0.5 - 6.5 D min. 46	... 17
Typ .0.736	Klemmhalter, zum Abstechen, Außenbearbeitung	toolholder, for parting off, external application	Stechbreite width of groove S 0.5 - 1.2 t max. 8	... 18

SYSTEM DED

Einstecken mit dreischneidigen Wendeplatten

grooving with three-cutting edges indexable inserts

Übersicht

summary

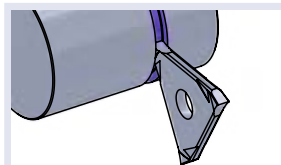

**Wendeschneidplatten
geprägt,
Stechdrehen**

**indexable inserts
fixed with claw,
grooving**

**Maße
dimensions
[mm]**

**Seite
page**

Typ Stechdrehen	für Sicherungsringe DIN 471/472 und Stechdrehen allgemein	type grooving for circlips DIN 471/472 and general grooving	Stechbreite width of groove S 0.57 - 5.29	... 20
Typ Stechdrehen	für unterbrochene Schnitte und Sicherungsringe DIN 471/472	type grooving interrupted cuts, and circlips DIN 471/472	Stechbreite width of groove S 1.07 - 5.29	... 22
Typ Stechdrehen	für Sicherungsringe DIN 471/472, stabile Ausführung	type grooving for circlips DIN 471/472, solid construction	Stechbreite width of groove C 0.55 - 1.05	... 23
Typ Stechdrehen	für Sicherungsringe DIN 471/472, mit Nutaußenkantenfasung	type grooving for circlips DIN 471/472, with chamfer	Stechbreite width of groove C 1.24 - 5.29	... 24
Typ Stechdrehen	zum Feindreihen	type grooving for finishing	Stechbreite width of groove S 1.0 - 4.0	... 26
Typ Stechdrehen	Vollradius, für Nuten und Eckenfreistich	type grooving full radius, for grooving and corner reliefs	Stechbreite width of groove S 0.5 - 5.0	... 27
Typ Stechdrehen	mit Spanformer, zum Abstechen	type grooving with chipformer, for parting off	Stechbreite width of groove S 1.99 - 2.79	... 28
Typ Stechdrehen	ohne Spanformer, zum Abstechen	type grooving without chipformer, for parting off	Stechbreite width of groove S 0.5 - 1.4	... 29
Typ Stechdrehen	zum Einstecken und Längsdrehen	type grooving for grooving and turning	Stechbreite width of groove C 3.29 t max. 3.5	... 30
Typ Stechdrehen	für Eckenfreistich, ähnlich DIN 509 Form F	type grooving for corner reliefs, similar to DIN 509 type F	Stechbreite width of groove S 2.4 - 5.0	... 31
Typ Stechdrehen	Poly-V-Riemennuten, für Poly-V-Profil J und K	Poly-V-Belt Grooves, for Poly-V-profiles J and K	Stechbreite width of groove S 3.3 / 4.3	... 32
Typ Stechdrehen	Axialbearbeitung	type grooving, face grooving	Stechbreite width of groove C 1.5 - 5.0 t max. 3.5	... 33



SYSTEM DED

Einstecken mit dreischneidigen Wendeplatten

grooving with three-cutting edges indexable inserts

Übersicht

summary

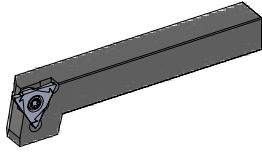

Klemmhalter geschraubt

toolholder screwed

Maße dimensions [mm]

Seite page

Typ .208

Klemmhalter, Außenbearbeitung

toolholder, external application

Spannbereich holding capacity
S 5.5
t max. 5.5

... 34

Typ .619

Klemmhalter 45°, Axialeinstecken, Außenbearbeitung

toolholder 45°, face grooving, external application

Spannbereich holding capacity
S 3.3

... 35

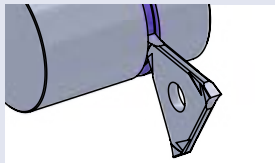

Wendeschneidplatten geschraubt, Stechdrehen

indexable inserts screwed, grooving

Maße dimensions [mm]

Seite page

Typ Stechdrehen

Axialeinstecken, eingebaut unter 45°

type grooving, face grooving, mounted in a 45° toolholder

Stechbreite width of groove
C 1.5 - 2.4
t max. 2.0

... 36

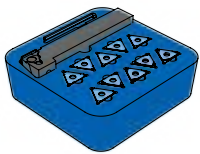

Sets System DED

sets system DED

Maße dimensions [mm]

Seite page

Halter (Rechte Ausführung) und Schneiden

toolholder (righthand version) and inserts

SET-DED 1

- für Sicherungsringe DIN 471 / 472
- und Stechdrehen allgemein

- for circlips DIN 471 / 472
- and general grooving

Stechbreite width of groove
S 0.57 - 1.99

... 37

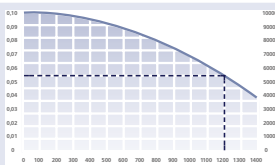

Technische Hinweise

Technical Instructions

Seite page

Hartmetallsorten und Beschichtungen

carbide grades and coatings

... 74

Schnittdatenempfehlung

speed and feed recommendation

... 78

SYSTEM D-GROOVING

Einstecken mit
ein- oder zweischneidigen
Schneideinsätzen

grooving with
one- or two-cutting edges
inserts

Übersicht

summary



Allgemeine Beschreibung
Spangeometrien

general instructions
cutting geometries

... 38

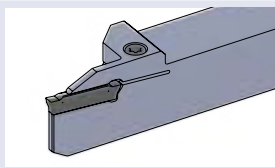

Klemmhalter

toolholder

**Maße
dimensions
[mm]**

**Seite
page**

Typ DH

Klemmhalter,
Außenbearbeitung

toolholder,
external application

Spannbereich
holding capacity
b 2.0 - 3.0
t max. 13

... 42

Typ DH

Klemmhalter,
Außenbearbeitung

toolholder,
external application

Spannbereich
holding capacity
b 3.0 - 6.0
t max. 25

... 43

Typ DH ... -IK

Klemmhalter,
mit Innenkühlung,
Außenbearbeitung

toolholder,
with internal cooling,
external application

Spannbereich
holding capacity
b 2.0 - 4.0
t max. 13 / 25

... 44

Typ DS

Klemmhalter; Swisstype
Außenbearbeitung

toolholder; Swisstype
external application

Spannbereich
holding capacity
b 2.0 - 3.0
t max. 13 / 21

... 45

Typ DS ... -IK

Klemmhalter; Swisstype
mit Innenkühlung,
Außenbearbeitung

toolholder; Swisstype
with internal cooling,
external application

Spannbereich
holding capacity
b 2.0 - 3.0
t max. 13 / 21

... 46

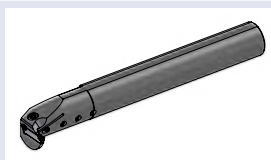

Bohrstange

grooving boring bar

**Maße
dimensions
[mm]**

**Seite
page**

Typ DI...D24-IK

Bohrstange mit Innenkühlung,
Innenbearbeitung

grooving boring bar
with internal cooling,
internal application

Spannbereich
holding capacity
b 2.0 - 5.0
t max. 12

... 47

SYSTEM D-GROOVING

Einstecken mit
ein- oder zweischneidigen
Schneideinsätzen

grooving with
one- or two-cutting edges
inserts

Übersicht

summary

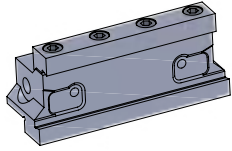

**Spannblock
(für Einsatz mit Klinge)**

**clamping block
(for use with blade)**

**Maße
dimensions
[mm]**

**Seite
page**

Typ SBD.

Spannblock,
Einsatz mit Klinge,
Außenbearbeitung

clamping block,
usable with blade,
external application

Klinge / blade
H = 26 / 32

... 48

Typ SBD. ... -IK

Spannblock,
Einsatz mit Klinge,
mit Innenkühlung,
Außenbearbeitung

clamping block,
usable with blade,
with internal cooling,
external application

Klinge / blade
H = 26 / 32

... 49

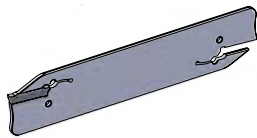

**Klinge
(für Einsatz mit Spannblock)**

**blade
(for use with
clamping block)**

**Maße
dimensions
[mm]**

**Seite
page**

Typ DKD24

Klinge,
für Schneideinsatz DZ24 / DE24

blade,
for insert DZ24 / DE24

Stechbreite
width of groove
b 2.0 - 4.0
t max. 50

... 50

Typ DKD24-IK

Klinge,
mit Innenkühlung,
für Schneideinsatz DZ24 / DE24

blade,
with internal cooling,
for insert DZ24 / DE24

Stechbreite
width of groove
b 2.0 - 4.0
t max. 50

... 52

Typ DKDEK

Klinge,
für Schneideinsatz DEK

blade,
for insert DEK

Stechbreite
width of groove
b 2.0 - 4.0
t max. 50

... 54

Typ DKDEK-IK

Klinge,
mit Innenkühlung,
für Schneideinsatz DEK

blade,
with internal cooling,
for insert DEK

Stechbreite
width of groove
b 2.0 - 4.0
t max. 50

... 56

SYSTEM D-GROOVING

Einstecken mit ein- oder zweischneidigen Schneideinsätzen

grooving with one- or two-cutting edges inserts

Übersicht

summary

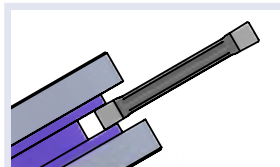

Schneideinsatz lang, zweischneidig, Stechdrehen

insert long, two-cutting edges, grooving

Maße dimensions [mm]

Seite page

Typ DZ24.M1	Schneideinsatz lang, zweischneidig, Spanformer M1	insert long, two-cutting edges, chipbreaker M1	Stechbreite width of groove b 2.0 - 6.0	... 58
Typ DZ24.F1	Schneideinsatz lang, zweischneidig, Spanformer F1	insert long, two-cutting edges, chipbreaker F1	Stechbreite width of groove b 2.0 - 5.0	... 59
Typ DZ24.S1	Schneideinsatz lang, zweischneidig, Spanformer S1	insert long, two-cutting edges, chipbreaker S1	Stechbreite width of groove b 2.0 - 6.0	... 60
Typ DZ24.T1	Schneideinsatz lang, zweischneidig, Spanformer T1	insert long, two-cutting edges, chipbreaker T1	Stechbreite width of groove b 2.0 - 6.0	... 61
Typ DZ24.MV	Schneideinsatz lang, zweischneidig, Spanformer MV (Vollradius)	insert long, two-cutting edges, chipbreaker MV (full radius)	Stechbreite width of groove b 2.0 - 6.0	... 62
Typ DZ24.LM	Schneideinsatz lang, zweischneidig, Spanformer LM	insert long, two-cutting edges, chipbreaker LM	Stechbreite width of groove b 2.0 - 6.0	... 63

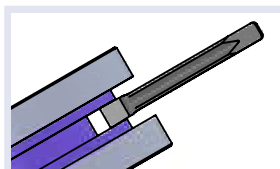

Schneideinsatz lang, einschneidig, Stechdrehen

insert long, single-edge, grooving

Maße dimensions [mm]

Seite page

Typ DE24.M1	Schneideinsatz lang, einschneidig, Spanformer M1	insert long, single-edge, chipbreaker M1	Stechbreite width of groove b 2.0 - 4.0	... 64
Typ DE24.F1	Schneideinsatz lang, einschneidig, Spanformer F1	insert long, single-edge, chipbreaker F1	Stechbreite width of groove b 2.0 - 4.0	... 65
Typ DE24.S1	Schneideinsatz lang, einschneidig, Spanformer S1	insert long, single-edge, chipbreaker S1	Stechbreite width of groove b 2.0 - 4.0	... 66
Typ DE24.T1	Schneideinsatz lang, einschneidig, Spanformer T1	insert long, single-edge, chipbreaker T1	Stechbreite width of groove b 2.0 - 4.0	... 67
Typ DE24.LM	Schneideinsatz lang, einschneidig, Spanformer LM	insert long, single-edge, chipbreaker LM	Stechbreite width of groove b 2.0 - 4.0	... 68



SYSTEM D-GROOVING

Einstecken mit ein- oder zweischneidigen Schneideinsätzen

grooving with one- or two-cutting edges inserts

Übersicht

summary

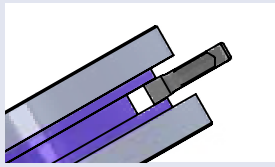

Schneideinsatz kurz, einschneidig, Stechdrehen

insert short, single-edge, grooving

Maße dimensions [mm]

Seite page

Typ DEK.M1	Schneideinsatz kurz, einschneidig, Spanformer M1	insert short, single-edge, chipbreaker M1	Stechbreite width of groove b 2.0 - 4.0	... 69
Typ DEK.M2	Schneideinsatz kurz, einschneidig, Spanformer M2	insert short, single-edge, chipbreaker M2	Stechbreite width of groove b 2.0 - 4.0	... 70
Typ DEK.S1	Schneideinsatz kurz, einschneidig, Spanformer S1	insert short, single-edge, chipbreaker S1	Stechbreite width of groove b 2.0 - 4.0	... 71
Typ DEK.LM	Schneideinsatz kurz, einschneidig, Spanformer LM	insert short, single-edge, chipbreaker LM	Stechbreite width of groove b 2.0 - 4.0	... 72

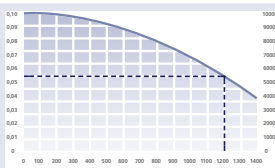

Technische Hinweise

Technical Instructions

Seite page

Allgemeine Informationen Hinweise zur Klemmung und zum Wechseln der Schneideinsätze	General informations Hints how to insert and remove the inserts	... 73
Hartmetallsorten und Beschichtungen	carbide grades and coatings	... 76
Schnittdatenempfehlung	speed and feed recommendation	... 82

SYSTEM DED

Einstecken mit
dreischneidigen Wendeplatten

grooving with three-cutting
edges indexable inserts

Allgemeine Beschreibung

general instruction

System DED:

Das bewährte System zum Einstecken und Abstecken ab 0.5 mm Breite.

System DED:

Proven system for grooving and turning off from a width of 0.5 mm starting.

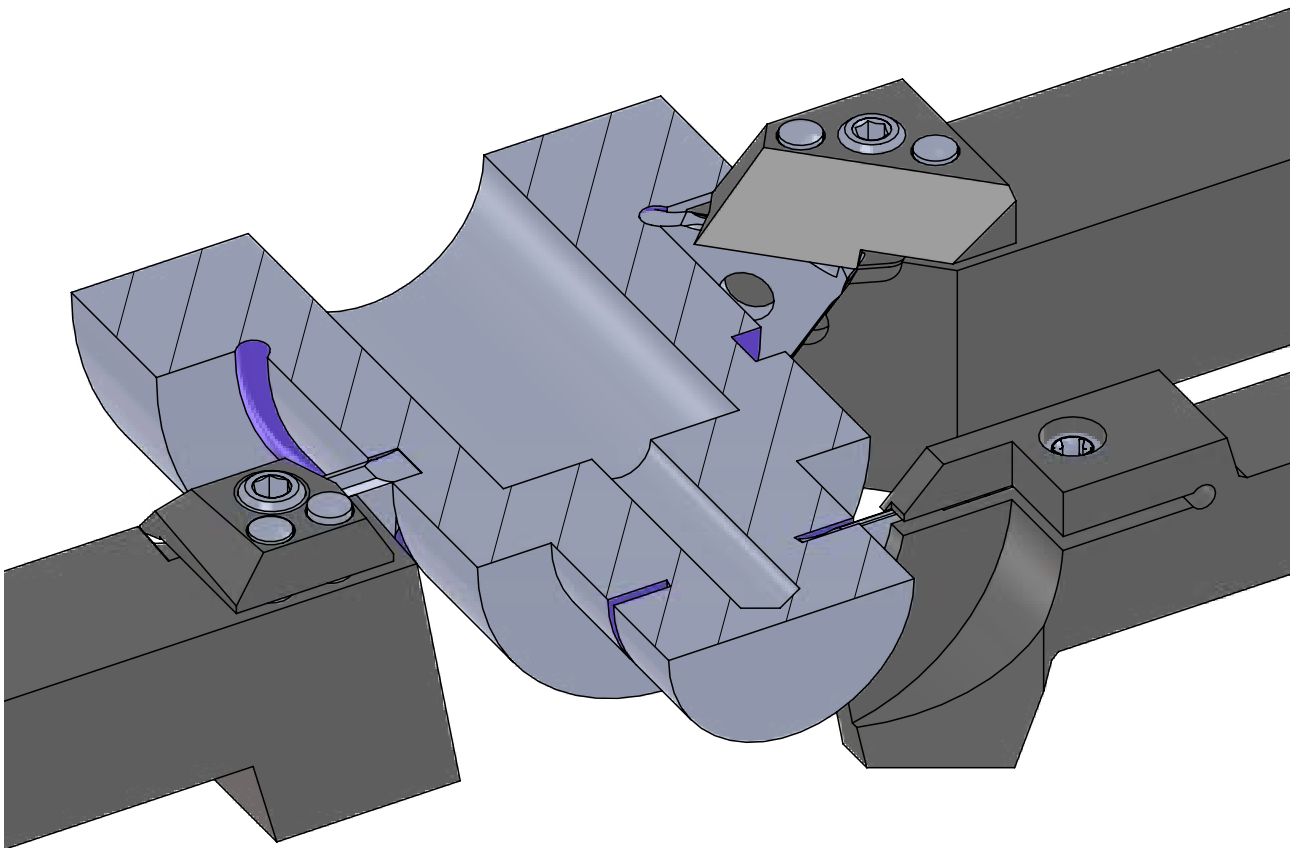

SYSTEM DED

Einstecken mit dreischneidigen Wendeplatten

grooving with three-cutting edges indexable inserts

Typ .207

Klemmhalter, Außenbearbeitung

toolholder, external application

Stechtiefe t max. 6 mm
Spannbereich S 0.5 - 6.5 mm

depth of groove t max. 6 mm
holding capacity S 0.5 - 6.5 mm

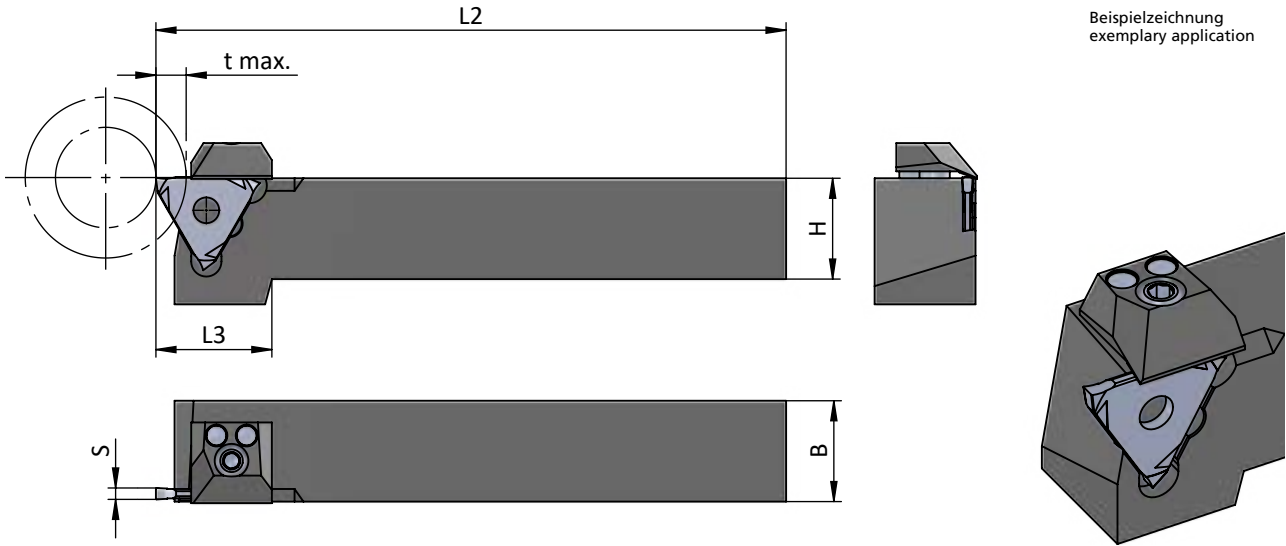

Beispielzeichnung
exemplary application

Rechts (R): wie gezeichnet
Links (L): spiegelbildlich

righthand (R): as shown
lefthand version (L): mirror image

Abmessungen in mm

dimensions in mm

Bestellnummer part number	H	B	H x B (inch)	*t max.	L2	L3	Spannpratze claw	Spannschraube screw	Schraubenschlüssel wrench	Führungsstifte guide pin	Spannbereich S holding capacity S	Wende- schneidplatte S indexable insert S
R/L .207.1212.1-D	12	12		4	100	28	R.207. ... : PD21/R L.207. ... : PD21/L	A.DGS001	111.INB3	A.ZST001	0.5 - 2.0	
R/L .207.1616.1-D	16	16		4	125	26						
R/L .207.2020.1-D	20	20		4	125	23						
R/L .207.2525.1-D	25	25		4	150	-						
R/L .207.U.1000.1-D	25.4	25.4	1"x1"	4	150	-						
R/L .207.3232.1-D	32	32		4	170	-					1.9 - 3.0	
R/L .207.1212.2-D	12	12		6	100	28						
R/L .207.1616.2-D	16	16		6	125	26						
R/L .207.2020.2-D	20	20		6	125	23						
R/L .207.2525.2-D	25	25		6	150	-						
R/L .207.3232.2-D	32	32		6	170	-						
↳ ...												

*tmax. reduziert bei Werkstück Ø > 40
*tmax. reduced for workpiece Ø > 40

Spitzenhöhe JS14

center height JS14

SYSTEM DED

Einstecken mit dreischneidigen Wendeplatten

grooving with three-cutting edges indexable inserts

Typ .207

Klemmhalter, Außenbearbeitung

toolholder, external application

Stechtiefe t max. 6 mm
Spannbereich S 0.5 - 6.5 mm

depth of groove t max. 6 mm
holding capacity S 0.5 - 6.5 mm

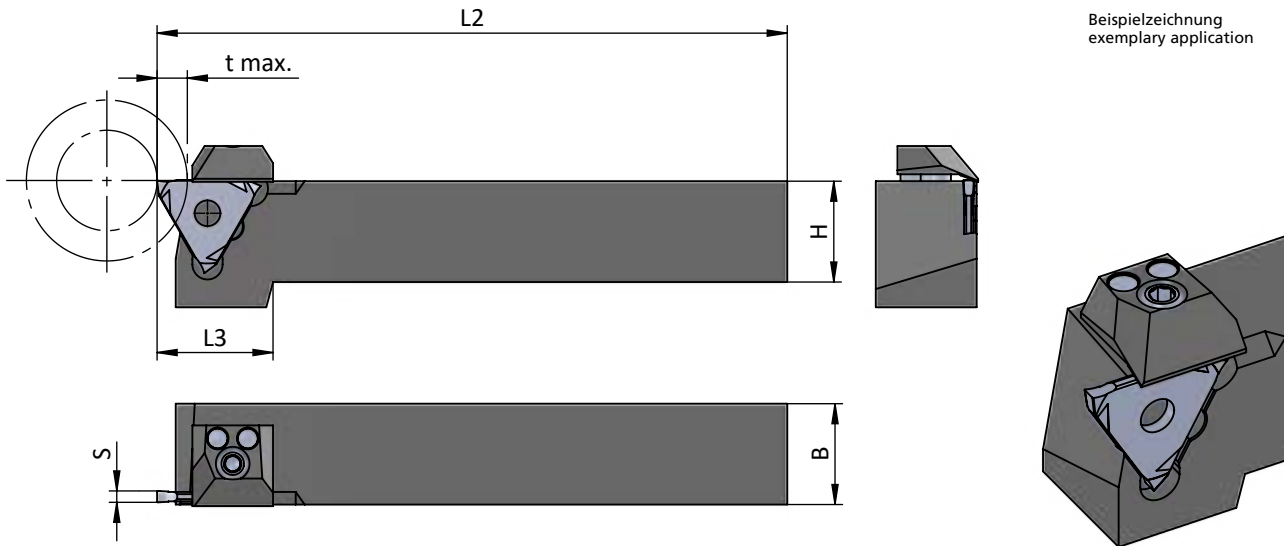

Beispielzeichnung
exemplary application

Rechts (R): wie gezeichnet
Links (L): spiegelbildlich

righthand (R): as shown
lefthand version (L): mirror image

Abmessungen in mm

dimensions in mm

Bestellnummer part number	H	B	H x B (inch)	*t max.	L2	L3	Spannpratze claw	Spannschraube screw	Schraubenschlüssel wrench	Führungsstifte guide pin	Spannbereich S holding capacity S	Wende- schneidplatte S indexable insert S
R/L .207.1212.3-D	12	12		6	100	28						
R/L .207.1616.3-D	16	16		6	125	26						
R/L .207.2020.3-D	20	20		6	125	23		A.DGS001	111.INB3	A.ZST001	2.9 - 4.0	
R/L .207.2525.3-D	25	25		6	150	-	R.207. ... : PD21/R L.207. ... : PD21/L					
R/L .207.3232.3-D	32	32		6	170	-						
R/L .207.1616.4-D	16	16		6	125	26						
R/L .207.2020.4-D	20	20		6	125	23						
R/L .207.2525.4-D	25	25		6	150	-	R.207. ... : PD25/R L.207. ... : PD25/L	A.DGS001	111.INB3	A.ZST001	3.9 - 6.5	
R/L .207.3232.4-D	32	32		6	170	-						

*tmax. reduziert bei Werkstück Ø > 40
*tmax. reduced for workpiece Ø > 40

Spitzenhöhe JS14

center height JS14

Bestellbeispiel:
für rechte Ausführung
R.207.1212.3-D

order-example:
righthand version
R.207.1212.3-D

SYSTEM DED

Einstecken mit dreischneidigen Wendeplatten

grooving with three-cutting edges indexable inserts

Typ .207....-IK

Klemmhalter, Außenbearbeitung, innere Kühlmittelzufuhr

toolholder, external application, through coolant

Stechtiefe t max. 6 mm
Spannbereich S 0.5 - 4.0 mm

depth of groove t max. 6 mm
holding capacity S 0.5 - 4.0 mm

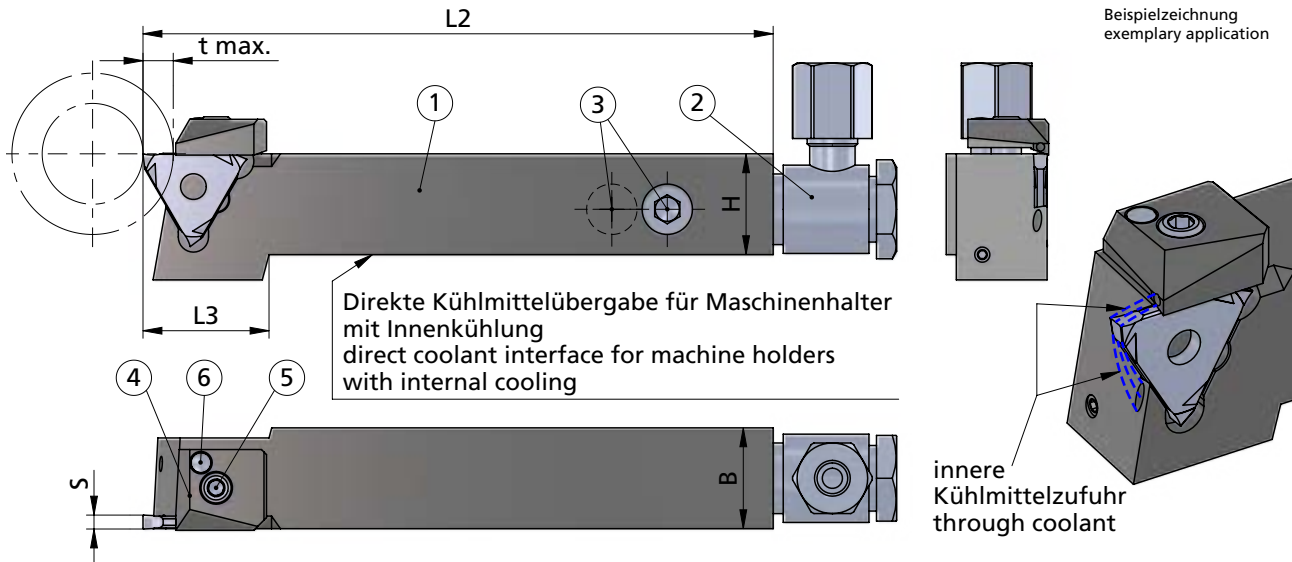

Beispielzeichnung
exemplary application

Rechts (R): wie gezeichnet
Links (L): spiegelbildlich

righthand (R): as shown
lefthand version (L): mirror image

Abmessungen in mm

dimensions in mm



Bestellnummer part number	H		B	*t max.	L2	L3	Kühlmittelanschl. cooling connection		Gewindestift threaded pin		Spannpratze claw	Spannschraube screw	Schraubenschlüssel wrench	Führungsstift guide pin	Spannbereich S holding capacity S	Wende- schneidplatte S indexable insert S
	Pos.1	Pos.2	Pos.3	Pos.4	Pos.5	Pos.6	WSR-Anschluss-M8x1	WSR-Anschluss-G1/8	VS-M8x1x5	VS-G1/8x6						
R/L .207.1212.1-IK	12	12	4	100	25		●									
R/L .207.1616.1-IK	16	16	4	125	24		●								0.5 - 2.0	
R/L .207.2020.1-IK	20	20	4	125	24		●									
R/L .207.2525.1-IK	25	25	4	150	-		●									
R/L .207.1212.2-IK	12	12	6	100	27		●									
R/L .207.1616.2-IK	16	16	6	125	26		●								1.9 - 3.0	
R/L .207.2020.2-IK	20	20	6	125	25		●									
R/L .207.2525.2-IK	25	25	6	150	-		●									
R/L .207.1212.3-IK	12	12	6	100	28		●									
R/L .207.1616.3-IK	16	16	6	125	26		●									
R/L .207.2020.3-IK	20	20	6	125	25		●									
R/L .207.2525.3-IK	25	25	6	150	-		●								2.9 - 4.0	

*tmax. reduziert bei Werkstück Ø > 40
*tmax. reduced for workpiece Ø > 40

Spitzenhöhe JS14

center height JS14

Bestellbeispiel:
für rechte Ausführung
R.207.1212.1-IK

order-example:
righthand version
R.207.1212.1-IK

SYSTEM DED

Einstecken mit dreischneidigen Wendeplatten

grooving with three-cutting edges indexable inserts

Typ .0.780

Klemmhalter, Außenbearbeitung

toolholder, external application

Stechtiefe t max. 8 mm
Spannbereich S 1.4 - 6.5 mm

depth of groove t max. 8 mm
holding capacity S 1.4 - 6.5 mm



Beispielzeichnung
exemplary application

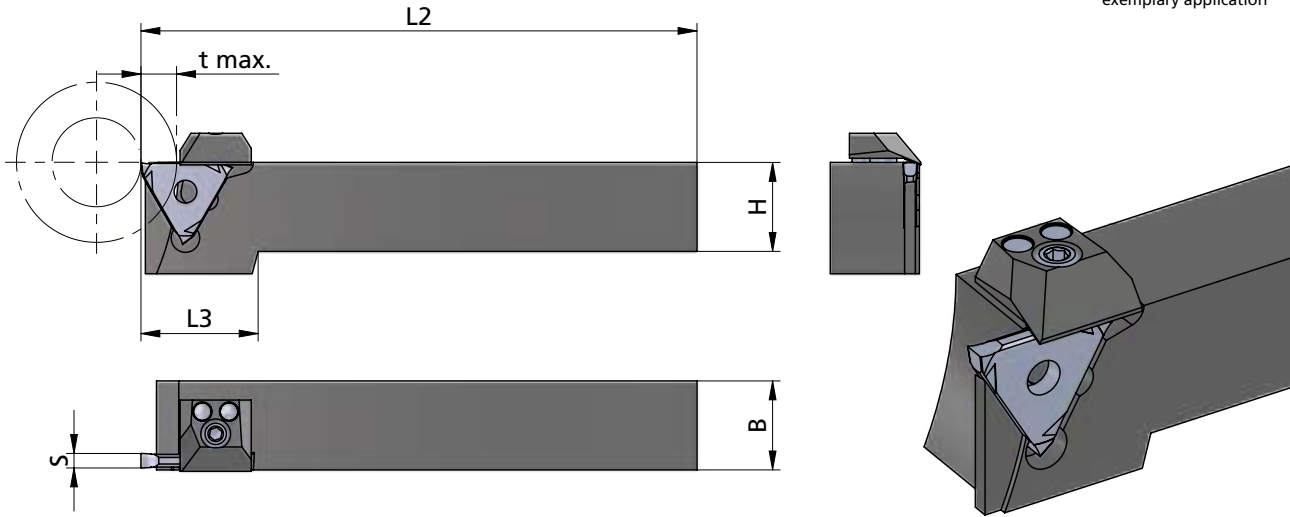

Rechts (R): wie gezeichnet
Links (L): spiegelbildlich

righthand (R): as shown
lefthand version (L): mirror image

Abmessungen in mm

dimensions in mm

Bestellnummer part number	H	B	*t max.	L2	L3	Spannpratze claw	Spannschraube screw	Schraubenschlüssel wrench	Führungsstifte guide pin	Spannbereich S holding capacity S	Wende- schneidplatte S indexable insert S
R/L .0.780.2020.1-D	20	20	8	125	25	R.0.780. ... : PD21/R L.0.780. ... : PD21/L	A.DG5001	111.INB3	A.ZST001	1.4 - 2.0	
R/L .0.780.2525.1-D	25	25	8	150	-					1.9 - 3.0	
R/L .0.780.2020.2-D	20	20	8	125	25					2.9 - 4.0	
R/L .0.780.2525.2-D	25	25	8	150	-						
R/L .0.780.3232.2-D	32	32	8	170	-						
R/L .0.780.2020.3-D	20	20	8	125	25					R.0.780. ... : PD25/R L.0.780. ... : PD25/L	
R/L .0.780.2525.3-D	25	25	8	150	-						
R/L .0.780.3232.3-D	32	32	8	170	-						
R/L .0.780.2020.4-D	20	20	8	125	25						
R/L .0.780.2525.4-D	25	25	8	150	-						
R/L .0.780.3232.4-D	32	32	8	170	-						

*tmax. reduziert bei Werkstück Ø > 125
*tmax. reduced for workpiece Ø > 125

Bestellbeispiel:
für rechte Ausführung
R.0.780.2020.1-D

order-example:
righthand version
R.0.780.2020.1-D

SYSTEM DED

Einstecken mit dreischneidigen Wendeplatten

grooving with three-cutting edges indexable inserts

Typ .0.782

Klemmhalter, Außenbearbeitung

toolholder, external application

Stechtiefe t max. 8 mm
Spannbereich S 0.5 - 1.9 mm

depth of groove t max. 8 mm
holding capacity S 0.5 - 1.9 mm

Beispielzeichnung
exemplary application

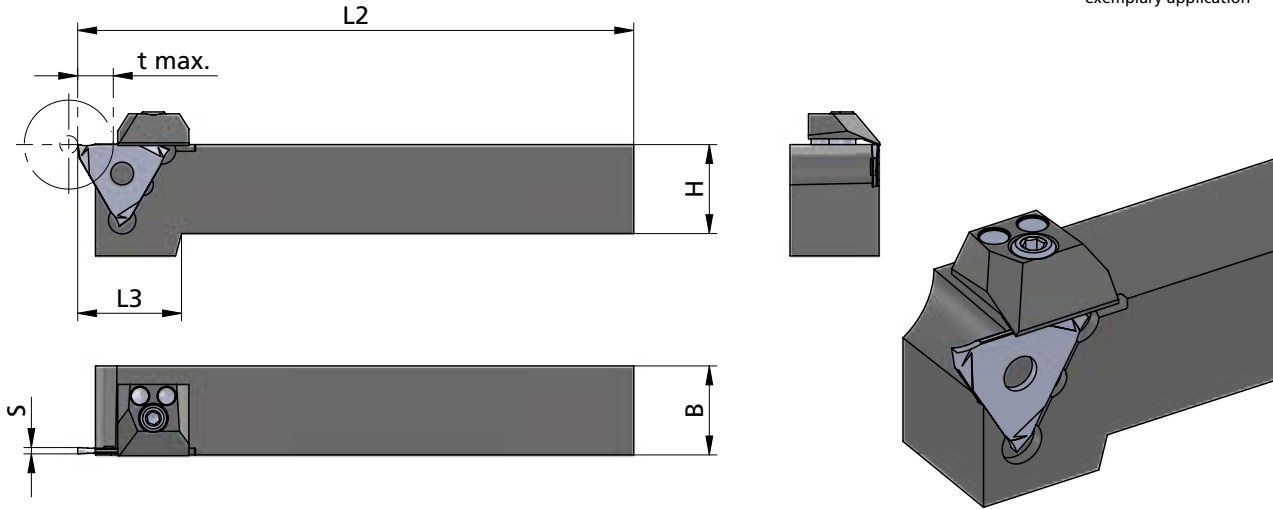

Rechts (R): wie gezeichnet
Links (L): spiegelbildlich

righthand (R): as shown
lefthand version (L): mirror image

Abmessungen in mm

dimensions in mm

Bestellnummer part number	H	B	*t max.	L2	L3	Spannpratze claw	Spannschraube screw	Schraubenschlüssel wrench	Führungsstifte guide pin	Spannbereich S holding capacity S	Wende- schneidplatte S indexable insert S
R/L .0.782.1212.1-D	12	12	8	100	26	R.0.782. ... : PD21/R L.0.782. ... : PD21/L	A.DGS001	111.INB3	A.ZST001	0.5 - 2.0	
R/L .0.782.1616.1-D	16	16	8	125	26						
R/L .0.782.2020.1-D	20	20	8	125	26						
R/L .0.782.2525.1-D	25	25	8	150	-						

*tmax. reduziert bei Werkstück Ø > 20
*tmax. reduced for workpiece Ø > 20

SYSTEM DED

Einstecken mit dreischneidigen Wendeplatten

grooving with three-cutting edges indexable inserts

Typ .0.738

Klemmhalter, gekröpft, Außenbearbeitung

toolholder, cranked, external application

Stechtiefe t max. 6 mm
Spannbereich S 0.5 - 6.5 mm

depth of groove t max. 6 mm
holding capacity S 0.5 - 6.5 mm

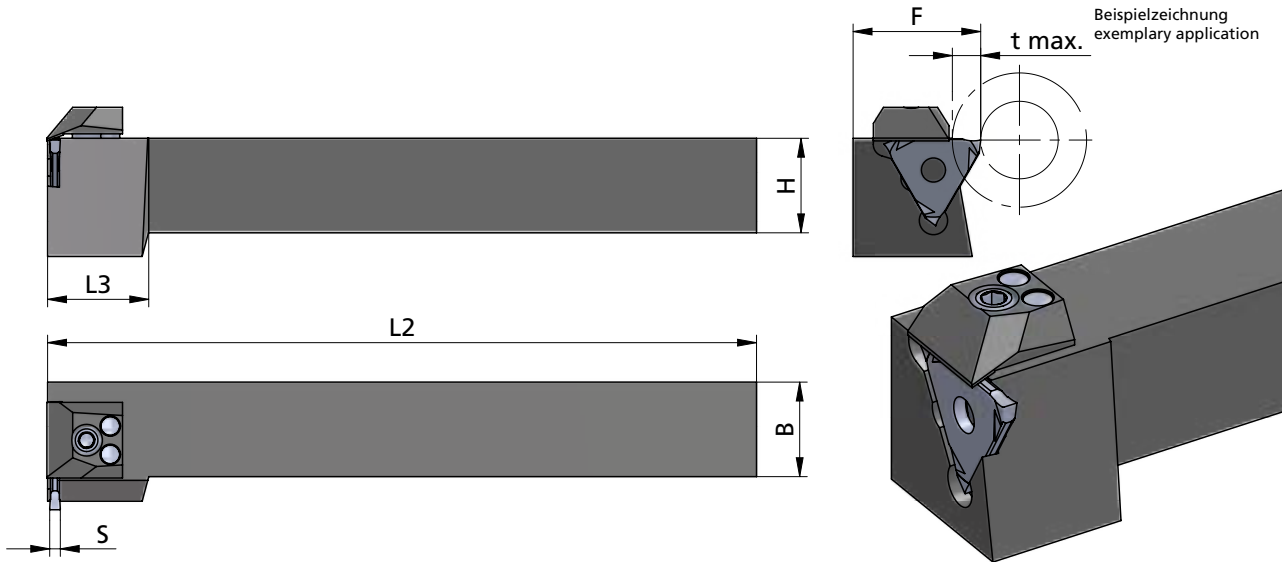

Rechts (R): wie gezeichnet
Links (L): spiegelbildlich

righthand (R): as shown
lefthand version (L): mirror image

Abmessungen in mm

dimensions in mm

Bestellnummer part number	H	B	F	*t max.	L2	L3	Spannpratze claw	Spannschraube screw	Schraubenschlüssel wrench	Führungsstifte guide pin	Spannbereich S holding capacity S	Wende- schneidplatte S indexable insert S
R/L .0.738.2020.1-D	20	20	27	4	150	20	R.0.738...: PD21/L L.0.738...: PD25/R	A.DGS001	111.INB3	A.ZST001	0.5 - 2.0	
R/L .0.738.2525.1-D	25	25	32	4	150	-					1.9 - 3.0	
R/L .0.738.2020.2-D	20	20	27	6	150	20					2.9 - 4.0	
R/L .0.738.2525.2-D	25	25	32	6	150	-					3.9 - 6.5	
R/L .0.738.2020.3-D	20	20	27	6	150	20						
R/L .0.738.2525.3-D	25	25	32	6	150	-						
R/L .0.738.2020.4-D	20	20	27	6	150	20						
R/L .0.738.2525.4-D	25	25	32	6	150	-						

*tmax. reduziert bei Werkstück Ø > 40
*tmax. reduced for workpiece Ø > 40

Bestellbeispiel:
für rechte Ausführung
R.0.738.2020.1-D

order-example:
righthand version
R.0.738.2020.1-D

SYSTEM DED

Einstecken mit dreischneidigen Wendepplatten

grooving with three-cutting edges indexable inserts

Typ .0.618

Klemmhalter 45°, für Eckenfreistriche, Außenbearbeitung

toolholder 45°, for corner reliefs, external application

Spannbereich S 1.9 - 6.5 mm

holding capacity S 1.9 - 6.5 mm

Beispielzeichnung
exemplary application

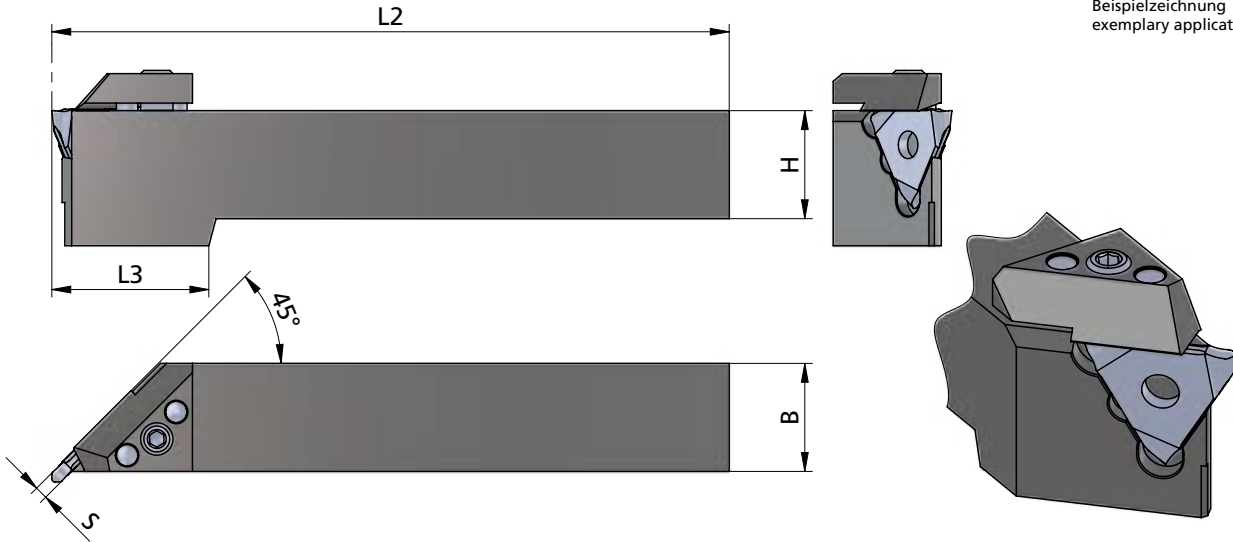

Rechts (R): wie gezeichnet
Links (L): spiegelbildlich

righthand (R): as shown
lefthand version (L): mirror image

Abmessungen in mm

dimensions in mm



Bestellnummer part number	H	B	L2	L3	Spannpratze claw	Spannschraube screw	Schraubenschlüssel wrench	Führungsstifte guide pin	Spannbereich S holding capacity S	Wende- schneidplatte S indexable insert S				
R/L .0.618.2020.2-D	20	20	125	30	R.0.618. ... : PD22/R L.0.618. ... : PD22/L	A.DGS001	111.INB3	A.ZST001	1.9 - 3.0					
R/L .0.618.2525.2-D	25	25	150	-										
R/L .0.618.3232.2-D	32	32	170	-										
R/L .0.618.2020.3-D	20	20	125	30					R.0.618. ... : PD23/R L.0.618. ... : PD23/L	A.DGS001	111.INB3	A.ZST001	2.9 - 4.0	
R/L .0.618.2525.3-D	25	25	150	-										
R/L .0.618.3232.3-D	32	32	170	-										
R/L .0.618.2020.4-D	20	20	125	30	R.0.618. ... : PD23/R L.0.618. ... : PD23/L	A.DGS001	111.INB3	A.ZST001	3.9 - 6.5					
R/L .0.618.2525.4-D	25	25	150	-										
R/L .0.618.3232.4-D	32	32	170	-										

SYSTEM DED

Einstecken mit dreischneidigen Wendepplatten

grooving with three-cutting edges indexable inserts

Typ .0.660

Bohrstange, Innenbearbeitung

grooving boring bar, internal application

D min. 46 mm
Spannbereich S 0.5 - 6.5 mm

D min. 46 mm
holding capacity S 0.5 - 6.5 mm

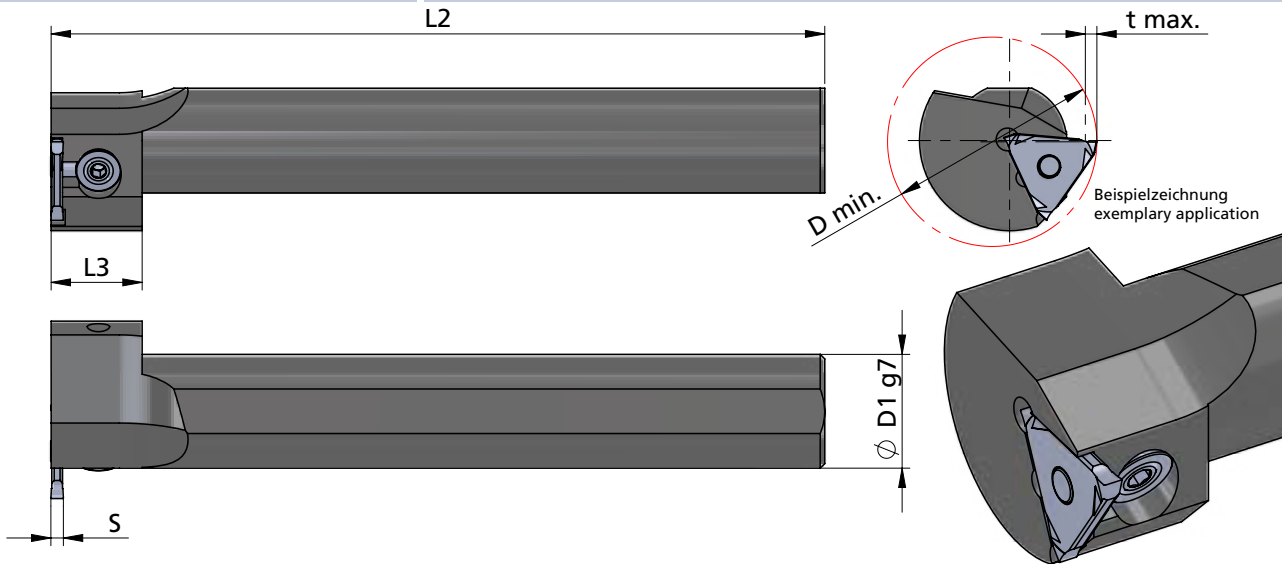

Rechts (R): wie gezeichnet
Links (L): spiegelbildlich

righthand (R): as shown
lefthand version (L): mirror image

Abmessungen in mm

dimensions in mm

Bestellnummer part number	Ø D1 g7	*D min.	*t max.	L2	L3	Spannpratze claw	Spannschraube screw	Schraubenschlüssel wrench	Spannbereich S holding capacity S	Wende- schneidplatte S indexable insert S
R/L .0.660.0025.1-D	25	46		170	20	PD.0.660.2	A.DGS002	111.INB3	0.5 - 2.0	
R/L .0.660.0032.1-D	32	46		200	20					
R/L .0.660.0040.1-D	40	46		250	-					
R/L .0.660.0025.2-D	25	46		170	20					
R/L .0.660.0032.2-D	32	46		200	20					
R/L .0.660.0040.2-D	40	46		250	-					
R/L .0.660.0025.3-D	25	46		170	20					
R/L .0.660.0032.3-D	32	46		200	20					
R/L .0.660.0040.3-D	40	46		250	-					
R/L .0.660.0025.4-D	25	46		170	20					
R/L .0.660.0032.4-D	32	46		200	20					
R/L .0.660.0040.4-D	40	46		250	-					

*D min.	46	50	60	80	100
*Stechtiefe t max. / max. depth of groove	2	3	4	4.5	5

Bestellbeispiel:
für rechte Ausführung
R.0.660.0025.1-D

order-example:
righthand version
R.0.660.0025.1-D



SYSTEM DED

Einstecken mit dreischneidigen Wendeplatten

grooving with three-cutting edges indexable inserts

Typ .0.736

Klemmhalter, zum Abstechen, Außenbearbeitung

toolholder, for parting off, external application

Stechtiefe t max. 8 mm
Stechbreite S 0.5 - 1.2 mm

depth of groove t max. 8 mm
width of groove S 0.5 - 1.2 mm

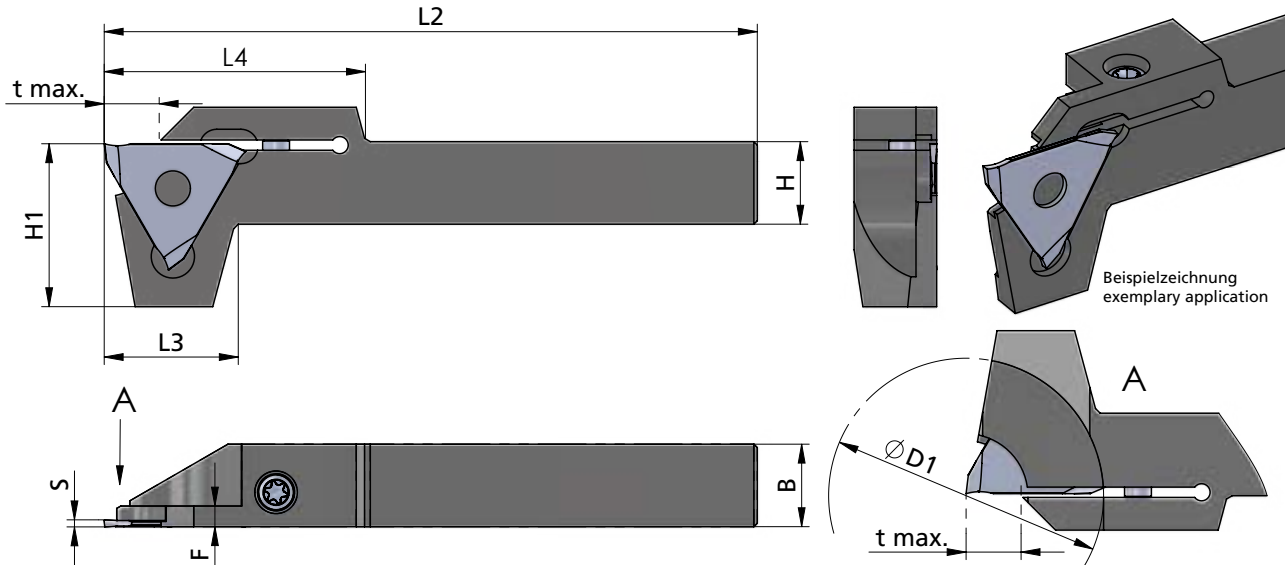

Rechts (R): wie gezeichnet
Links (L): spiegelbildlich

righthand (R): as shown
lefthand version (L): mirror image

Abmessungen in mm

dimensions in mm

Bestellnummer part number	H = B	H1	t max.	L2	L3	L4	F	Ø D1	Spannschraube screw	Schraubenschlüssel wrench	für Wende- schneidplatten for indexable inserts	Stechbreite S width of groove S
R/L .0.736.1212-D	12	24	8	95	19.5	38	3	40	A.SPS026	TR15-P	R/L DED.0805.00	0.5
											R/L DED.0808.00	0.8
											R/L DED.0510.00	1.0
											R/L DED.0512.00	1.2
											R/L DED.1210.00	1.0
R/L .0.736.1616-D	16	24	8	95	19.5	38	3	40	A.SPS026	TR15-P	R/L DED.0805.00	0.5
											R/L DED.0808.00	0.8
											R/L DED.0510.00	1.0
											R/L DED.0512.00	1.2
											R/L DED.1210.00	1.0

SYSTEM DED

Einstecken mit
dreischneidigen Wendeplatten

grooving with three-cutting
edges indexable inserts

Impressionen

impressions

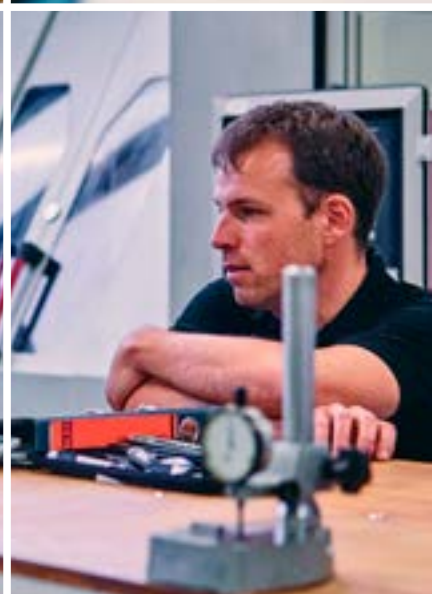
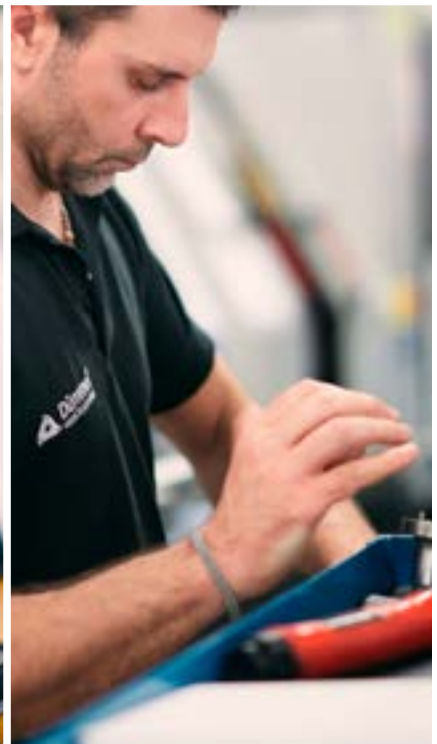

SYSTEM DED

Einstecken mit dreischneidigen Wendepplatten

grooving with three-cutting edges indexable inserts

Typ Stechdrehen

Wendeschneidplatte, für Sicherungsringe DIN 471 / 472 und Stechdrehen allgemein

indexable insert, for circlips DIN 471 / 472 and general grooving

Stechbreite S 0.57 - 5.29 mm

width of groove S 0.57 - 5.29 mm

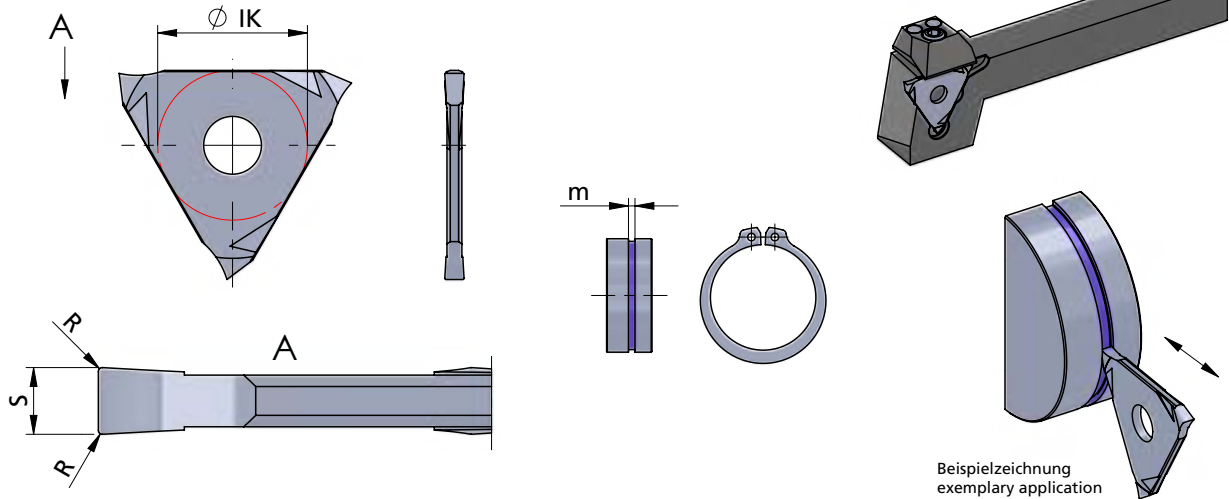

Beispielzeichnung
exemplary application

Wendeschneidplatten sind in rechten und linken Klemmhaltern sowie Bohrstängen verwendbar

inserts can be used in RH and LH toolholders as well as in boring bars

Abmessungen in mm

dimensions in mm

Bestellnummer part number	Nut-Maß m groove dim. m DIN 471 / DIN 472	S -0.05	S (inch)	R	Ø IK					Klemmhalter Typ toolholder type	
						K10F	CN45F	AL41F	P07C		
DED.0050.00	0.5	0.57		0.05	13.0	●	●	●		R/L .207.1-D R/L .0.738.1-D R/L .0.660.1-D R/L .0.780.1-D (S>1.4)	
DED.0060.00	0.6	0.67		0.05	13.0	●	●	●			
DED.U066.00	-	0.66	0.026"	0.05	13.0			●			
DED.0070.00	0.7	0.77		0.05	13.0	●	●	●			
DED.0080.00	0.8	0.87		0.05	13.0	●	●	●			
DED.0090.00	0.9	0.97		0.05	13.0	●	●	●			
DED.0100.00	1.0	1.07		0.1	13.0	●	●	●			
DED.0110.00	1.1	1.24		0.1	13.0	●	●	●			
DED.U117.00	-	1.17	0.046"	0.1	13.0			●			
DED.0130.00	1.3	1.44		0.1	13.0	●	●	●			
DED.U142.00	-	1.42	0.056"	0.1	13.0			●			
DED.0160.00	1.6	1.74		0.1	13.2	●	●	●			
DED.0185.00	1.85	1.99		0.1	13.2	●	●	●			
DED.U198.00	-	1.98	0.078"	0.1	13.2			●			
↳ ...											

Weitere HM Sorten können Sie in der Sortenübersicht im Kapitel "Technische Hinweise" und der Preisliste finden.

More carbide grades you can find in the grades summary in the chapter "technical instructions" and in the price list.

SYSTEM DED

Einstecken mit dreischneidigen Wendepplatten

grooving with three-cutting edges indexable inserts

Typ Stechdrehen

Wendeschneidplatte, für Sicherungsringe DIN 471 / 472 und Stechdrehen allgemein

indexable insert, for circlips DIN 471 / 472 and general grooving

Stechbreite S 0.57 - 5.29 mm

width of groove S 0.57 - 5.29 mm

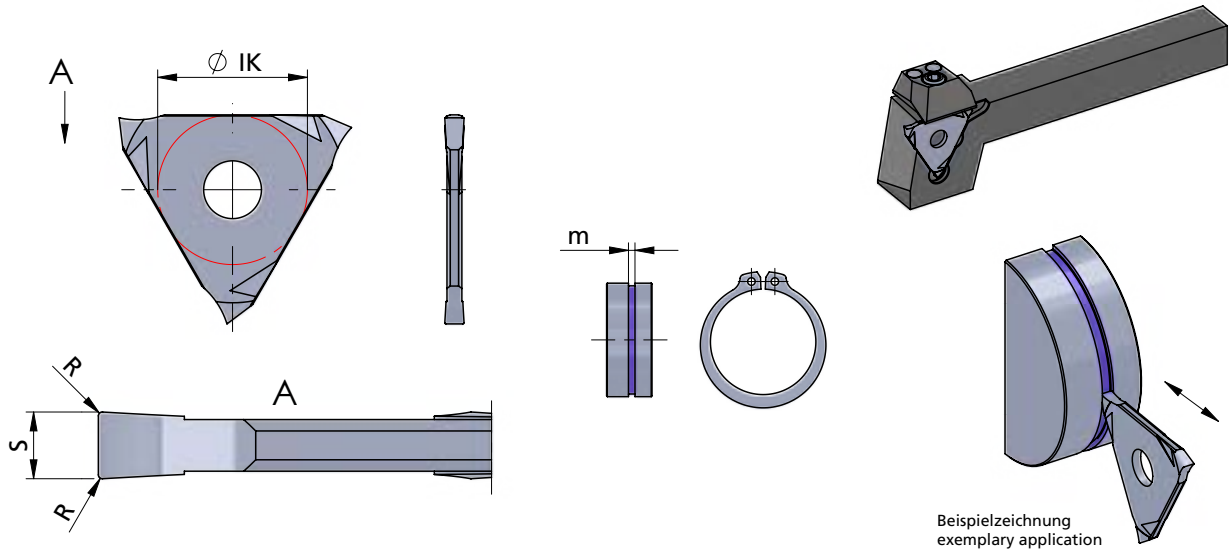

Wendeschneidplatten sind in rechten und linken Klemmhaltern sowie Bohrstängen verwendbar

inserts can be used in RH and LH toolholders as well as in boring bars

Abmessungen in mm

dimensions in mm

Bestellnummer part number	Nut-Maß m groove dim. m DIN 471 / DIN 472	S -0.05	S (inch)	R	Ø IK					Klemmhalter Typ toolholder type
						K10F	CN45F	AL41F	P07C	
DED.0215.00	2.15	2.29	0.088"	0.1	13.2	●	●	●		R/L .207. 2-D R/L .0.738. 2-D R/L .0.780. 2-D R/L .0.660. 2-D
DED.U223.00	-	2.23	0.088"	0.1	13.2			●		
DED.U238.00	-	2.38	0.094"	0.1	13.2			●		
DED.0265.00	2.65	2.79		0.1	13.2	●	●	●		
DED.0315.00	3.15	3.29		0.1	13.2	●	●	●		R/L .207. 3-D R/L .0.738. 3-D R/L .0.780. 3-D R/L .0.660. 3-D
DED.U398.00	-	3.98	0.157"	0.1	13.2			●		
DED.0415.00	4.15	4.29		0.1	13.2	●	●	●		R/L .207. 4-D R/L .0.738. 4-D R/L .0.780. 4-D R/L .0.660. 4-D
DED.0515.00	5.15	5.29		0.1	13.2	●	●	●		

Weitere HM Sorten können Sie in der Sortenübersicht im Kapitel "Technische Hinweise" und der Preisliste finden.

More carbide grades you can find in the grades summary in the chapter "technical instructions" and in the price list.

Bestellbeispiel:
für Sorte AL41F:
DED.0215.00/AL41F

order-example:
grade AL41F:
DED.0215.00/AL41F

SYSTEM DED

Einstecken mit dreischneidigen Wendepplatten

grooving with three-cutting edges indexable inserts

Typ Stechdrehen

Wendeschneidplatte, für unterbrochene Schnitte und Sicherungsringe DIN 471 / 472

indexable insert, for interrupted cuts and circlips DIN 471 / 472

Stechbreite S 1.07 - 5.29 mm

width of groove S 1.07 - 5.29 mm

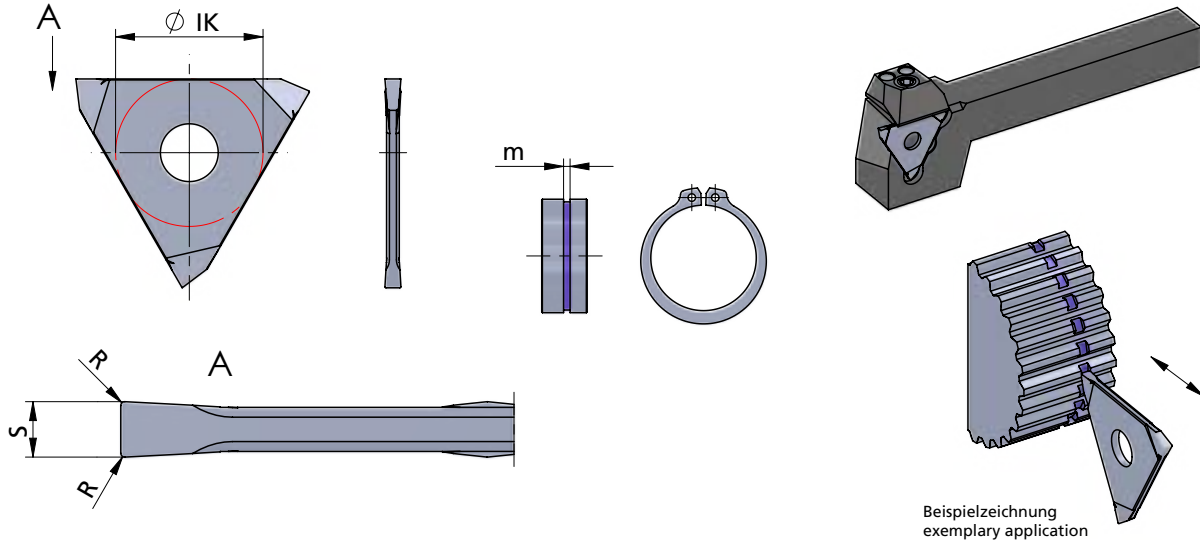

Beispielzeichnung
exemplary application

Wendeschneidplatten sind in rechten und linken Klemmhaltern sowie Bohrstängen verwendbar

inserts can be used in RH and LH toolholders as well as in boring bars

Abmessungen in mm

dimensions in mm

Bestellnummer part number	Nut-Maß m groove dim. m DIN 471 / DIN 472	S -0.05	R	Ø IK	Klemmhalter Typ toolholder type			
					K10F	CN45F	AL41F	P07C
DED.0100.NG-D	1.0	1.07	0.1	13.0	●	●	●	
DED.0110.NG-D	1.1	1.24	0.1	13.0	●	●	●	
DED.0130.NG-D	1.3	1.44	0.1	13.0	●	●	●	
DED.0160.NG-D	1.6	1.74	0.1	13.0	●	●	●	
DED.0185.NG-D	1.85	1.99	0.1	13.0	●	●	●	
DED.0215.NG-D	2.15	2.29	0.1	13.0	●	●	●	
DED.0265.NG-D	2.65	2.79	0.1	13.0	●	●	●	
DED.0315.NG-D	3.15	3.29	0.1	13.0	●	●	●	
DED.0415.NG-D	4.15	4.29	0.1	13.0	●	●	●	
DED.0515.NG-D	5.15	5.29	0.1	13.0	●	●	●	
								R/L .207.1-D R/L .0.738.1-D R/L .0.660.1-D R/L .0.780.1-D (S>1.4)
								R/L .207.2-D R/L .0.738.2-D R/L .0.780.2-D R/L .0.660.2-D
								R/L .207.3-D R/L .0.738.3-D R/L .0.780.3-D R/L .0.660.3-D
								R/L .207.4-D R/L .0.738.4-D R/L .0.780.4-D R/L .0.660.4-D

Weitere HM Sorten können Sie in der Sortenübersicht im Kapitel "Technische Hinweise" und der Preisliste finden.

More carbide grades you can find in the grades summary in the chapter "technical instructions" and in the price list.

Bestellbeispiel:
für Sorte AL41F:
DED.0100.NG-D/AL41F

order-example:
grade AL41F:
DED.0100.NG-D/AL41F

SYSTEM DED

Einstecken mit dreischneidigen Wendeplatten

grooving with three-cutting edges indexable inserts

Typ Stechdrehen

Wendeschneidplatte, für Sicherungsringe DIN 471 / 472, stabile Ausführung

indexable insert, for circlips DIN 471 / 472, solid construction

Stechbreite C 0.55 - 1.05 mm

width of groove C 0.55 - 1.05 mm

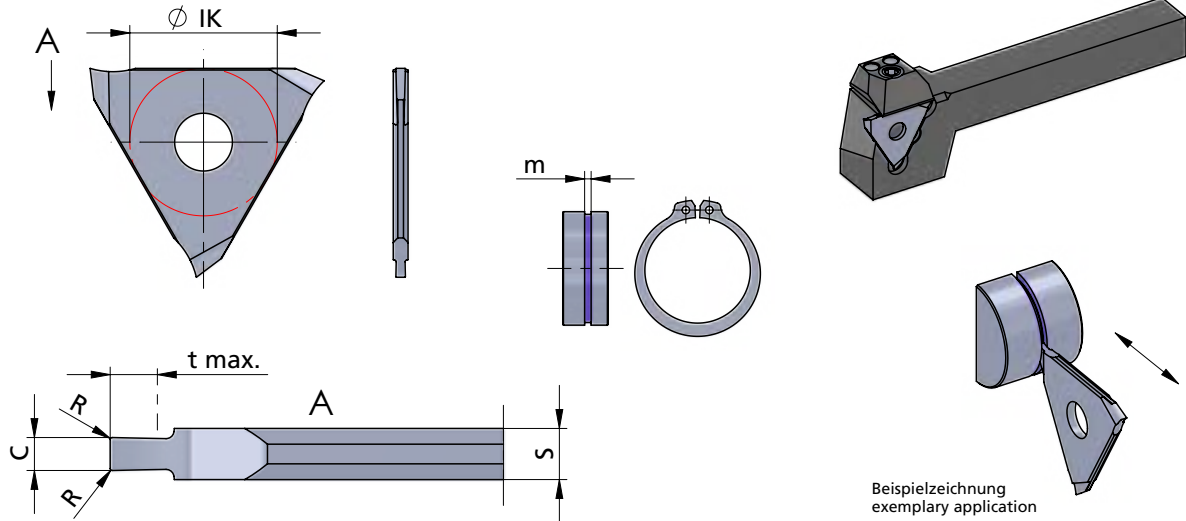

Wendeschneidplatten sind in rechten und linken Klemmhaltern sowie Bohrstängen verwendbar

inserts can be used in RH and LH toolholders as well as in boring bars

Abmessungen in mm

dimensions in mm

Bestellnummer part number	Nut-Maß m groove dim. m DIN 471 / DIN 472	C-0.03	S ±0.02	t max.	R	Ø IK	Klemmhalter Typ toolholder type			
							K10F	CN45F	AL41F	P07C
DED.0050.13	0.5	0.55	1.3	0.7	0.05	13.0	●	●		
DED.0060.13	0.6	0.65	1.3	0.8	0.05	13.0	●	●		
DED.0070.13	0.7	0.75	1.3	1.1	0.05	13.0	●	●		R/L .207,1-D
DED.0080.13	0.8	0.85	1.3	1.2	0.05	13.0	●	●		R/L .0.738,1-D
DED.0090.13	0.9	0.95	1.3	1.4	0.05	13.0	●	●		R/L .0.660,1-D
DED.0100.13	1.0	1.05	1.3	1.6	0.1	13.0	●	●		

Weitere HM Sorten können Sie in der Sortenübersicht im Kapitel "Technische Hinweise" und der Preisliste finden.

Bestellbeispiel:
für Sorte AL41F:
DED.0050.13/AL41F

More carbide grades you can find in the grades summary in the chapter "technical instructions" and in the price list.

order-example:
grade AL41F:
DED.0050.13/AL41F



SYSTEM DED

Einstecken mit dreischneidigen Wendeplatten

grooving with three-cutting edges indexable inserts

Typ Stechdrehen

Wendeschneidplatte, für Sicherungsringe DIN 471 / 472 mit Nutaußenkantenfasung

indexable insert, for circlips DIN 471 / 472 with chamfer

Stechbreite C 1.24 - 5.29 mm

width of groove C 1.24 - 5.29 mm

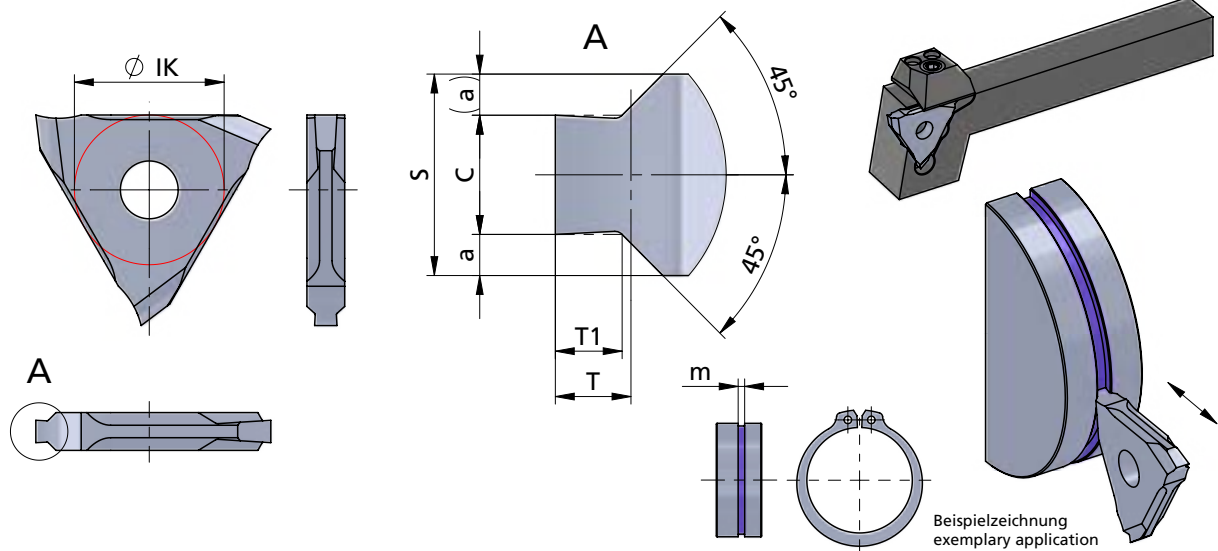

Beispielzeichnung
exemplary application

Wendeschneidplatten sind in rechten und linken Klemmhaltern sowie Bohrstängen verwendbar

inserts can be used in RH and LH toolholders as well as in boring bars

Abmessungen in mm

dimensions in mm

Bestellnummer part number	Nut-Maß m groove dim. m DIN 471 / DIN 472	C -0.05	S	a	T1 -0.05	T	Ø IK	K10F	CN45F	AL41F	P07C	Klemmhalter Typ toolholder type
DED.1101.25	1.1		1.24	2.5	0.64	0.19	0.20	●	●	●		R/L .207.2-D R/L .0.738.2-D R/L .0.780.2-D R/L .0.660.2-D
DED.1102.25	1.1		1.24	2.5	0.64	0.24	0.25	●	●	●		
DED.1103.25	1.1		1.24	2.5	0.64	0.29	0.30	●	●	●		
DED.1104.25	1.1		1.24	2.5	0.64	0.33	0.35	●	●	●		
DED.1105.25	1.1		1.24	2.5	0.64	0.36	0.40	●	●	●		
DED.1306.25	1.3		1.44	2.5	0.54	0.45	0.55	●	●	●		
DED.1607.33	1.6		1.74	3.3	0.79	0.60	0.70	●	●	●		R/L .207.3-D R/L .0.738.3-D R/L .0.780.3-D R/L .0.660.3-D
DED.1608.33	1.6		1.74	3.3	0.79	0.75	0.85	●	●	●		
DED.1609.33	1.6		1.74	3.3	0.79	0.85	1.00	●	●	●		
DED.1810.33	1.85		1.99	3.3	0.67	0.85	1.00	●	●	●		
DED.1812.33	1.85		1.99	3.3	0.67	1.10	1.25	●	●	●		
↳ ...												

Weitere HM Sorten können Sie in der Sortenübersicht im Kapitel "Technische Hinweise" und der Preisliste finden.

More carbide grades you can find in the grades summary in the chapter "technical instructions" and in the price list.

SYSTEM DED

Einstecken mit dreischneidigen Wendeplatten

grooving with three-cutting edges indexable inserts

Typ Stechdrehen

Wendeschneidplatte, für Sicherungsringe DIN 471 / 472 mit Nutaußenkantenfasung

indexable insert, for circlips DIN 471 / 472 with chamfer

Stechbreite C 1.24 - 5.29 mm

width of groove C 1.24 - 5.29 mm

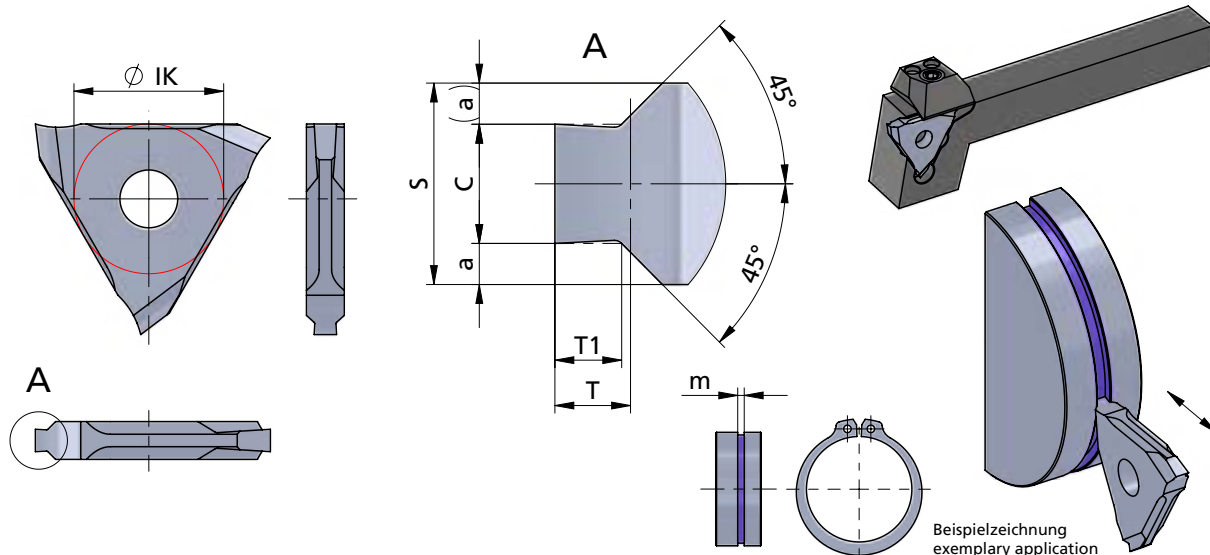

Beispielzeichnung
exemplary application

Wendeschneidplatten sind in rechten und linken Klemmhaltern sowie Bohrstäben verwendbar

inserts can be used in RH and LH toolholders as well as in boring bars

Abmessungen in mm

dimensions in mm



Bestellnummer part number	Nut-Maß m groove dim. m DIN 471 / DIN 472	C -0.05	S	a	T1 -0.05	T	Ø IK					Klemmhalter Typ toolholder type
								K10F	CN45F	AL41F	P07C	
DED.2115.43	2.15	2.29	4.3	1.02	1.35	1.50	13.2	●	●	●		R/L .207, 4-D R/L .0.738, 4-D R/L .0.780, 4-D R/L .0.660, 4-D
DED.2616.43	2.65	2.79	4.3	0.77	1.35	1.50	13.2	●	●	●		
DED.2617.43	2.65	2.79	4.3	0.77	1.60	1.75	13.2	●	●	●		
DED.3118.53	3.15	3.29	5.3	1.02	1.60	1.75	13.2	●	●	●		
DED.4120.53	4.15	4.29	5.3	0.52	1.85	2.00	13.2	●	●	●		
DED.4125.53	4.15	4.29	5.3	0.52	2.35	2.50	13.2	●	●	●		
DED.5130.63	5.15	5.29	6.3	0.52	2.85	3.00	13.2	●	●	●		

Weitere HM Sorten können Sie in der Sortenübersicht im Kapitel "Technische Hinweise" und der Preisliste finden.

More carbide grades you can find in the grades summary in the chapter "technical instructions" and in the price list.

Bestellbeispiel:
für Sorte AL41F:
DED.2115.43/AL41F

order-example:
grade AL41F:
DED.2115.43/AL41F

SYSTEM DED

Einstecken mit dreischneidigen Wendepplatten

grooving with three-cutting edges indexable inserts

Typ Stechdrehen

Wendeschneidplatte, zum Feindrehen

indexable insert, for finishing

Stechbreite S 1.0 - 4.0 mm

width of groove S 1.0 - 4.0 mm

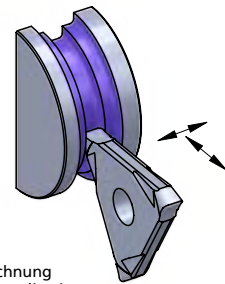
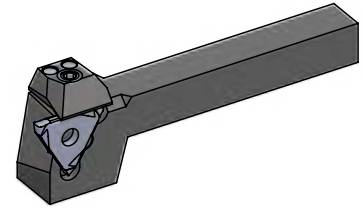
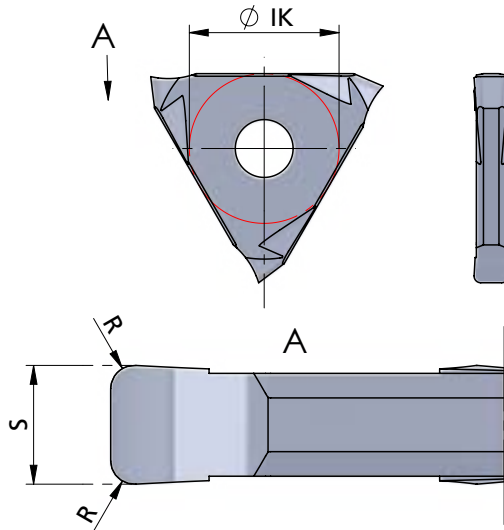

Beispielzeichnung
exemplary application

Wendeschneidplatten sind in rechten und linken Klemmhaltern sowie Bohrstängen verwendbar

inserts can be used in RH and LH toolholders as well as in boring bars

Abmessungen in mm

dimensions in mm

Bestellnummer part number	S +0.03	R	Ø IK					Klemmhalter Typ toolholder type
				K10F	CN45F	AL41F	P07C	
DED.0100.02	1.0	0.2	13.0	●		●		
DED.0150.02	1.5	0.2	13.0	●	●	●		R/L .207,1-D R/L .0.738,1-D (R/L .0.660,1-D)
DED.0200.02	2.0	0.2	13.2	●	●	●		R/L .0.780,1-D (S>1.4)
DED.0200.04	2.0	0.4	13.2	●	●	●		
DED.0300.02	3.0	0.2	13.2	●	●	●		R/L .207,2-D R/L .0.738,2-D (R/L .0.780,2-D)
DED.0300.06	3.0	0.6	13.2	●	●	●		(R/L .0.660,2-D)
DED.0300.08	3.0	0.8	13.2	●	●	●		
DED.0400.02	4.0	0.2	13.2	●	●	●		R/L .207,3-D R/L .0.738,3-D (R/L .0.780,3-D)
DED.0400.08	4.0	0.8	13.2	●	●	●		(R/L .0.660,3-D)
DED.0400.12	4.0	1.2	13.2	●	●	●		

Weitere HM Sorten können Sie in der Sortenübersicht im Kapitel "Technische Hinweise" und der Preisliste finden.

More carbide grades you can find in the grades summary in the chapter "technical instructions" and in the price list.

Bestellbeispiel:
für Sorte AL41F:
DED.0100.02/AL41F

order-example:
grade AL41F:
DED.0100.02/AL41F

SYSTEM DED

Einstecken mit dreischneidigen Wendeplatten

grooving with three-cutting edges indexable inserts

Typ Stechdrehen

Wendeschneidplatte, Vollradius, für Nuten und Eckenfreistich

indexable insert, full radius, for grooving and corner reliefs

Stechbreite S 0.5 - 5.0 mm

width of groove S 0.5 - 5.0 mm

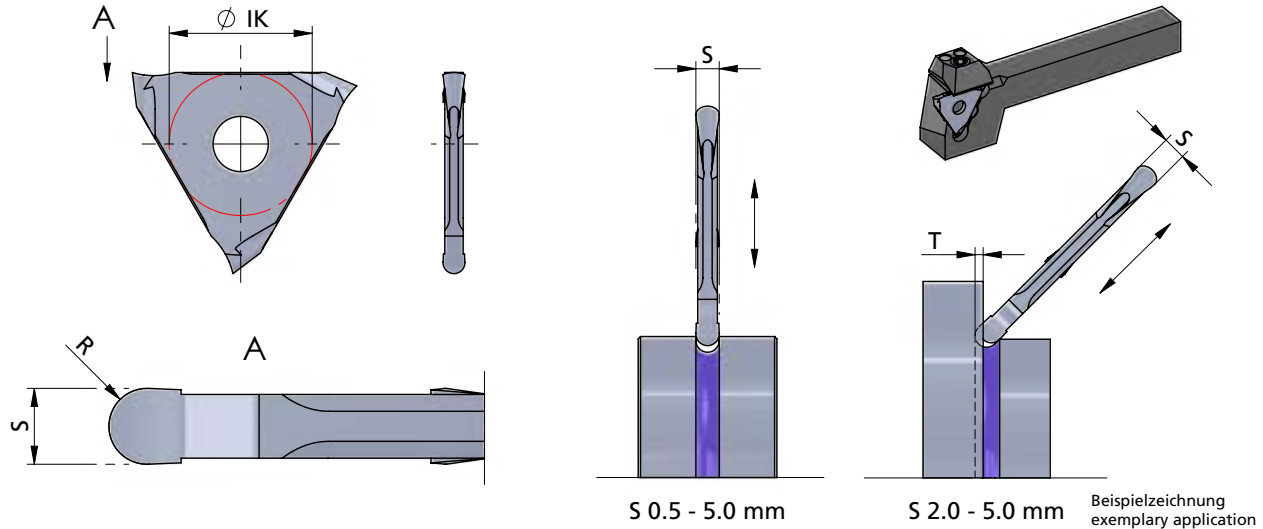

Wendeschneidplatten sind in rechten und linken Klemmhaltern sowie Bohrstängen verwendbar

Abmessungen in mm

inserts can be used in RH and LH toolholders as well as in boring bars

dimensions in mm

Bestellnummer part number	Abmessungen in mm					Material				Klemmhalter Typ	toolholder type
	S ±0.05	S ±0.02	R	T	Ø IK	K10F	CN45F	AL41F	P07C		
DED.0002.05		0.5	0.25		13.0	●	●	●		R/L .207, 1-D	
DED.0005.10		1.0	0.50		13.0	●	●	●		R/L .0.738, 1-D	
DED.0006.12		1.2	0.60		13.0	●	●	●		R/L .0.660, 1-D	
DED.0008.16		1.6	0.80		13.2	●	●	●		R/L .0.780, 1-D (S>1.4)	
DED.0010.20	2.0		1.00	0.70	13.2	●	●	●			
DED.0012.25	2.5		1.25	0.85	13.2	●	●	●		R/L .207, 2-D R/L .0.738, 2-D R/L .0.780, 2-D R/L .0.660, 2-D R/L .0.618, 2-D	
DED.0015.30	3.0		1.50	1.00	13.2	●	●	●		R/L .207, 3-D R/L .0.738, 3-D R/L .0.780, 3-D R/L .0.660, 3-D R/L .0.618, 3-D	
DED.0020.40	4.0		2.00	1.20	13.2	●	●	●		R/L .207, 4-D	
DED.0025.50	5.0		2.50	1.50	13.2	●	●	●		R/L .0.738, 4-D R/L .0.780, 4-D R/L .0.660, 4-D R/L .0.618, 4-D	

Weitere HM Sorten können Sie in der Sortenübersicht im Kapitel "Technische Hinweise" und der Preisliste finden.

Bestellbeispiel:
für Sorte AL41F:
DED.0002.05/AL41F

More carbide grades you can find in the grades summary in the chapter "technical instructions" and in the price list.

order-example:
grade AL41F:
DED.0002.05/AL41F



SYSTEM DED

Einstecken mit dreischneidigen Wendeplatten

grooving with three-cutting edges indexable inserts

Typ Stechdrehen

Wendeschneidplatte, mit Spanformer, zum Abstechen

indexable insert, with chipformer, for parting off

Stechbreite S 1.99 - 2.79 mm

width of groove S 1.99 - 2.79 mm

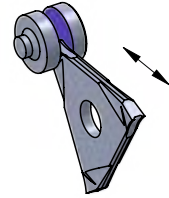
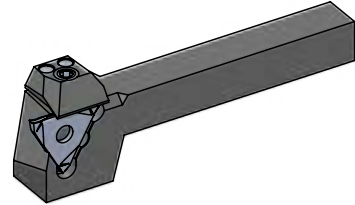
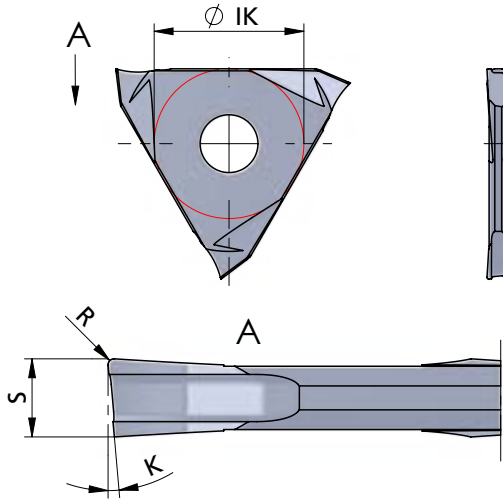

Beispielzeichnung
exemplary application

Rechts (R): wie gezeichnet
Links (L): spiegelbildlich

Wendeschneidplatten sind in rechten und linken Klemmhaltern verwendbar.
Abmessungen in mm

righthand version (R): as shown
lefthand version (L): mirror image

inserts can be used in RH and LH toolholders

dimensions in mm



Bestellnummer part number	S -0.05	K	R	Ø IK	K10F	CN45F	AL41F	P07C	Klemmhalter Typ	toolholder type
R/L .DED.0518.00	1.99	5°	0.15	13.0	●	●	●		R/L .207.1-D R/L .0.738.1-D R/L .0.780.1-D (S>1.4)	
R/L .DED.0521.00	2.29	5°	0.15	13.0	●	●	●		R/L .207.2-D	
R/L .DED.0526.00	2.79	5°	0.15	13.0	●	●	●		R/L .0.738.2-D R/L .0.780.2-D	

Weitere HM Sorten können Sie in der Sortenübersicht im Kapitel "Technische Hinweise" und der Preisliste finden.

Bestellbeispiel:
für rechte Ausführung und Sorte:
R.DED.0518.00/AL41F

More carbide grades you can find in the grades summary in the chapter "technical instructions" and in the price list.

order-example:
righthand version and grade:
R.DED.0518.00/AL41F

SYSTEM DED

Einstecken mit dreischneidigen Wendepplatten

grooving with three-cutting edges indexable inserts

Typ Stechdrehen

Wendeschneidplatte, ohne Spanformer, zum Abstechen

indexable insert, without chipformer, for parting off

Stechbreite S 0.5 - 1.4 mm

width of groove S 0.5 - 1.4 mm

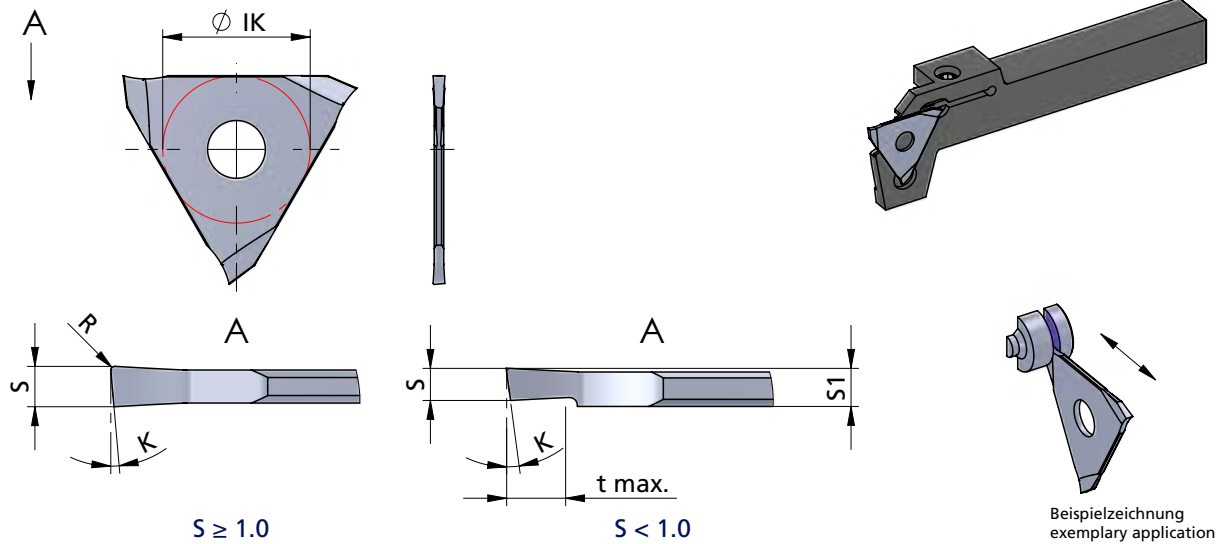

Rechts (R): wie gezeichnet
Links (L): spiegelbildlich

Wendeschneidplatten sind in rechten und linken Klemmhaltern verwendbar.
Abmessungen in mm

righthand version (R): as shown
lefthand version (L): mirror image

inserts can be used in RH and LH toolholders

dimensions in mm

Beispielzeichnung
exemplary application

Bestellnummer part number	S		K	R	t max.	Ø IK	Klemmhalter Typ toolholder type			
	S1 -0.05	S +0.05					K10F	CN45F	AL41F	P07C
R/L .DED.0805.00	1.0	0.5	8°		1.0	13.0	●	●		
R/L .DED.0808.00	1.0	0.8	8°		1.5	13.0	●	●		
R/L .DED.0510.00		1.0	5°	0.1		13.0	●	●		R/L .207.1-D R/L .0.736.
R/L .DED.0512.00		1.2	5°	0.1		13.0	●	●		
R/L .DED.1210.00		1.0	12°	0.1		13.0	●	●		
R/L .DED.0614.00		1.4	6°	0.1		13.0	●	●		R/L .207.1-D R/L .0.780.1-D (S>1.4)

Weitere HM Sorten können Sie in der Sortenübersicht im Kapitel "Technische Hinweise" und der Preisliste finden.

Bestellbeispiel:
für rechte Ausführung und Sorte:
R.DED.0805.00/AL41F

More carbide grades you can find in the grades summary in the chapter "technical instructions" and in the price list.

order-example:
righthand version and grade:
R.DED.0805.00/AL41F



SYSTEM DED

Einstecken mit dreischneidigen Wendeplatten

grooving with three-cutting edges indexable inserts

Typ Stechdrehen

Wendeschneidplatte, zum Einstecken und Längsdrehen

indexable insert, for grooving and turning

Stechtiefe t max. 3.5 mm
Stechbreite C 3.29 mm

depth of groove t max. 3.5 mm
width of groove C 3.29 mm

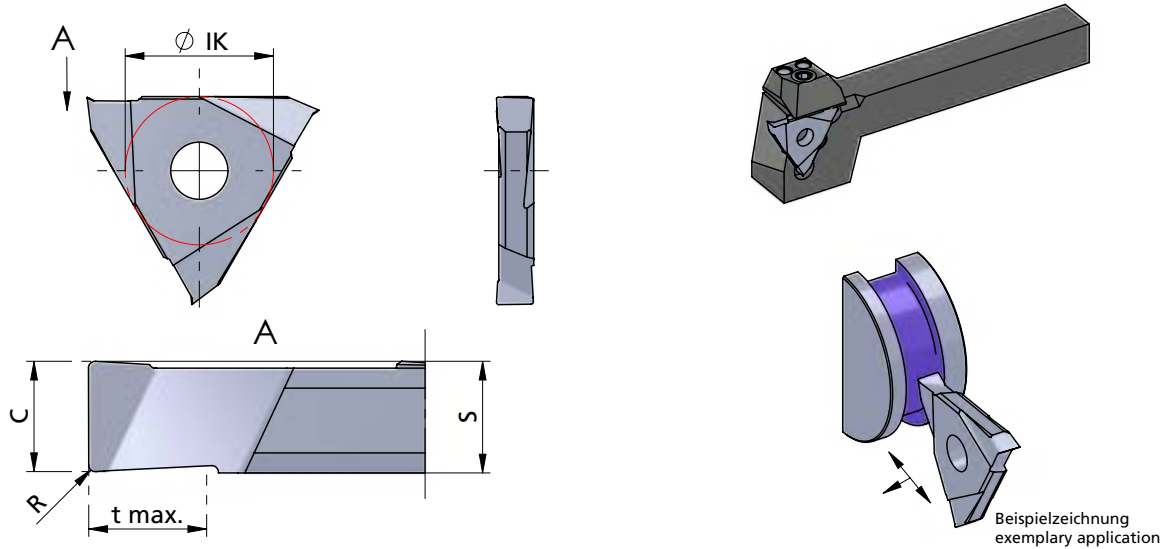

Rechts (R): wie gezeichnet
Links (L): spiegelbildlich

Rechte Schneidpl. in rechtem Halter
Linke Schneidpl. in linkem Halter

Abmessungen in mm

righthand version (R): as shown
lefthand version (L): mirror image

use RH insert in RH tool holder and
LH insert in LH tool holder

dimensions in mm

Bestellnummer
part number

C -0.05

S +0.05

R

t max.

Ø IK

K10F

CN45F

AL41F

P07C

Klemmhalter Typ

toolholder type

R/L .DED.3031.33

3.29

3.3

0.2

3.5

13.2

●

●

●

R/L .207.3-D
R/L .0.738.3-D

Weitere HM Sorten können Sie in der Sortenübersicht im Kapitel "Technische Hinweise" und der Preisliste finden.

Bestellbeispiel:
für rechte Ausführung und Sorte:
R.DED.3031.33/AL41F

More carbide grades you can find in the grades summary in the chapter "technical instructions" and in the price list.

order-example:
righthand version and grade:
R.DED.3031.33/AL41F

SYSTEM DED

Einstecken mit dreischneidigen Wendepplatten

grooving with three-cutting edges indexable inserts

Typ Stechdrehen

Wendeschneidplatte, für Eckenfreistich, ähnlich DIN 509 Form F

indexable insert, for corner reliefs, similar to DIN 509 type F

Stechbreite S 2.4 - 5.0 mm

width of groove S 2.4 - 5.0 mm

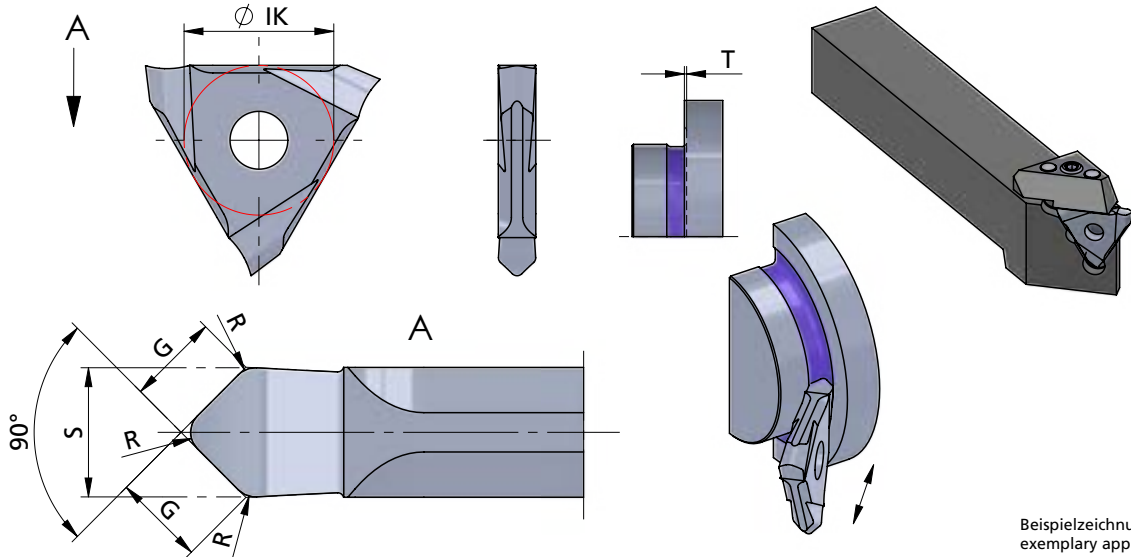

Beispielzeichnung
exemplary application

Wendeschneidplatten sind in rechten und linken Klemmhaltern verwendbar

inserts can be used in RH and LH toolholders

Abmessungen in mm

dimensions in mm

Bestellnummer part number						Ø IK					Klemmhalter Typ toolholder type
	S -0.05	G	R	T	K10F		CN45F	AL41F	P07C		
DED.0602.24	2.4	1.7	0.6	0.2	13.2	●	●	●		R/L .0.618.2-D	
DED.0603.33	3.3	2.3	0.6	0.3	13.2	●	●	●		R/L .0.618.3-D	
DED.1002.30	3.0	2.1	1.0	0.2	13.2	●	●	●		R/L .0.618.3-D	
DED.1004.50	5.0	3.6	1.0	0.4	13.2	●	●	●		R/L .0.618.4-D	
DED.1603.50	5.0	3.6	1.6	0.3	13.2	●	●	●		R/L .0.618.4-D	

Weitere HM Sorten können Sie in der Sortenübersicht im Kapitel "Technische Hinweise" und der Preisliste finden.

More carbide grades you can find in the grades summary in the chapter "technical instructions" and in the price list.

Bestellbeispiel:
für Sorte AL41F:
DED.0602.24/AL41F

order-example:
grade AL41F:
DED.0602.24/AL41F



SYSTEM DED

Einstecken mit dreischneidigen Wendeplatten

grooving with three-cutting edges indexable inserts

Typ Stechdrehen

Wendeschneidplatte, Poly-V-Riemennuten, für Poly-V-Profile J und K

indexable insert, Poly-V-Belt Grooves, for Poly-V-profiles J and K

Stechbreite S 3.3 und 4.3 mm

width of groove S 3.3 and 4.3 mm

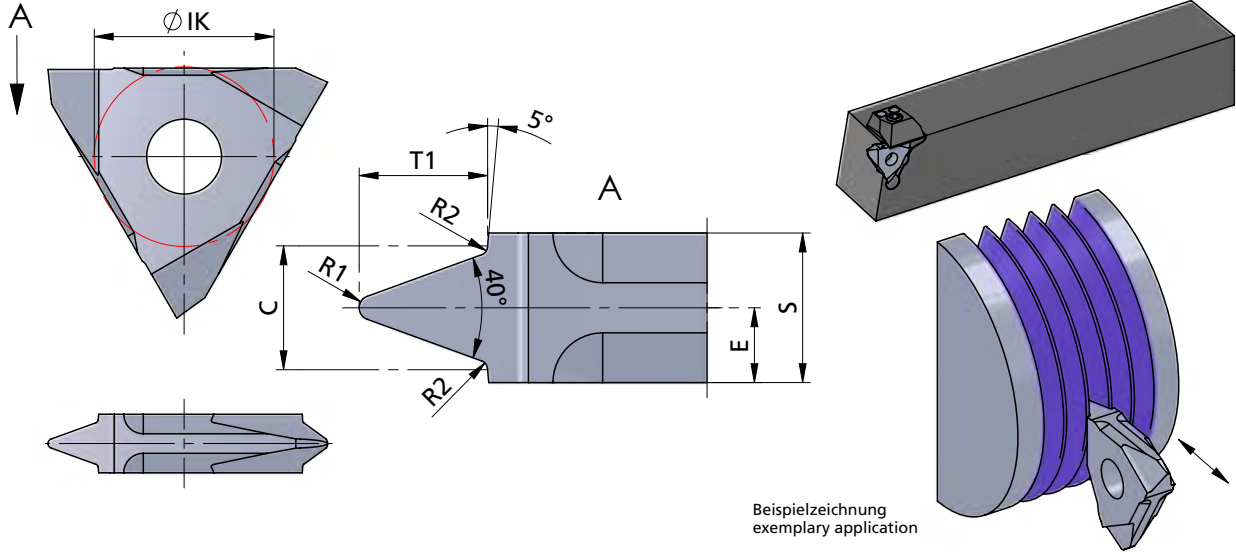

Wendeschneidplatten sind in rechten und linken Klemmhaltern sowie Bohrstängen verwendbar

inserts can be used in RH and LH toolholders as well as in boring bars

Abmessungen in mm

dimensions in mm

Bestellnummer part number	S ± 0.02	C	R1	R2	E	T1	Ø IK	Profil / profile	Klemmhalter Typ toolholder type				
									K10F	CN45F	AL41F	P07C	
DED.0223.33	3.3	2.34	0.25	0.2	1.65	2.3	13.2	J			●		R/L .207.3-D R/L .0.738.3-D
DED.0356.43	4.3	3.56	0.35	0.25	2.15	3.69	13.2	K			●		R/L .207.4-D R/L .0.738.4-D

Weitere HM Sorten können Sie in der Sortenübersicht im Kapitel "Technische Hinweise" und der Preisliste finden.

More carbide grades you can find in the grades summary in the chapter "technical instructions" and in the price list.

SYSTEM DED

Einstecken mit dreischneidigen Wendeplatten

grooving with three-cutting edges indexable inserts

Typ Stechdrehen

Wendeschneidplatte, Axialbearbeitung

indexable insert, face grooving

D min. 20 mm
Stechtiefe t max. 3.5 mm
Stechbreite C 1.5 - 5.0 mm

D min. 20 mm
depth of groove t max. 3.5 mm
width of groove C 1.5 - 5.0 mm

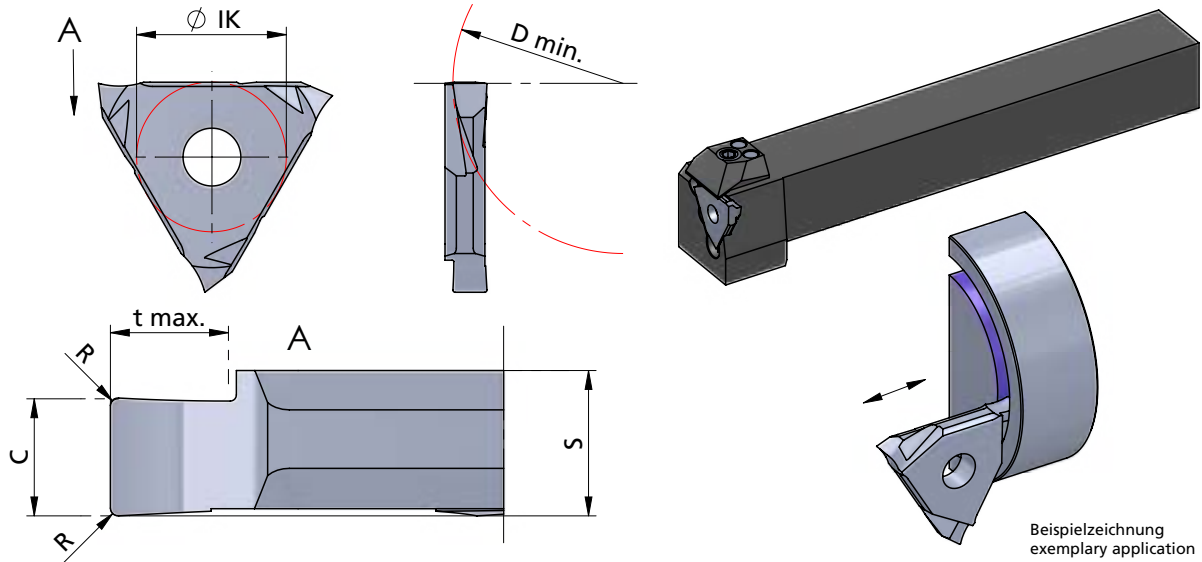

Links (L): wie gezeichnet
Rechts (R): spiegelbildlich

Wendeschneidplatten sind in rechten und linken Klemmhaltern verwendbar
Abmessungen in mm

lefthand version (L): as shown
righthand version (R): mirror image

inserts can be used in RH and LH toolholders

dimensions in mm

Bestellnummer part number	C ±0.02	S	R	t max.	D min.	Ø IK					Klemmhalter Typ toolholder type
							K10F	CN45F	AL41F	P07C	
R/L .DED.2015.2	1.5	2.7	0.2	2.0	20	13.2	●	●	●		(R/L .207.2-D) R/L .0.738.2-D
R/L .DED.3020.2	2.0	2.7	0.2	3.0	30	13.2	●	●	●		(R/L .207.3-D) R/L .0.738.3-D
R/L .DED.3030.2	3.0	3.7	0.2	3.0	30	13.2	●	●	●		(R/L .207.4-D) R/L .0.738.4-D
R/L .DED.3040.2	4.0	4.3	0.2	3.5	30	13.2	●	●	●		(R/L .207.4-D) R/L .0.738.4-D
R/L .DED.3050.2	5.0	5.3	0.2	3.5	30	13.2	●	●	●		(R/L .207.4-D) R/L .0.738.4-D

Weitere HM Sorten können Sie in der Sortenübersicht im Kapitel "Technische Hinweise" und der Preisliste finden.

Bestellbeispiel:
für rechte Ausführung und Sorte:
R.DED.2015.2/AL41F

More carbide grades you can find in the grades summary in the chapter "technical instructions" and in the price list.

order-example:
righthand version and grade:
R.DED.2015.2/AL41F



SYSTEM DED

Einstecken mit dreischneidigen Wendeplatten

grooving with three-cutting edges indexable inserts

Typ .208

Klemmhalter, Außenbearbeitung

toolholder, external application

Stechtiefe t max. 5.5 mm
Spannbereich S 5.5 mm

depth of groove t max. 5.5 mm
holding capacity S 5.5 mm

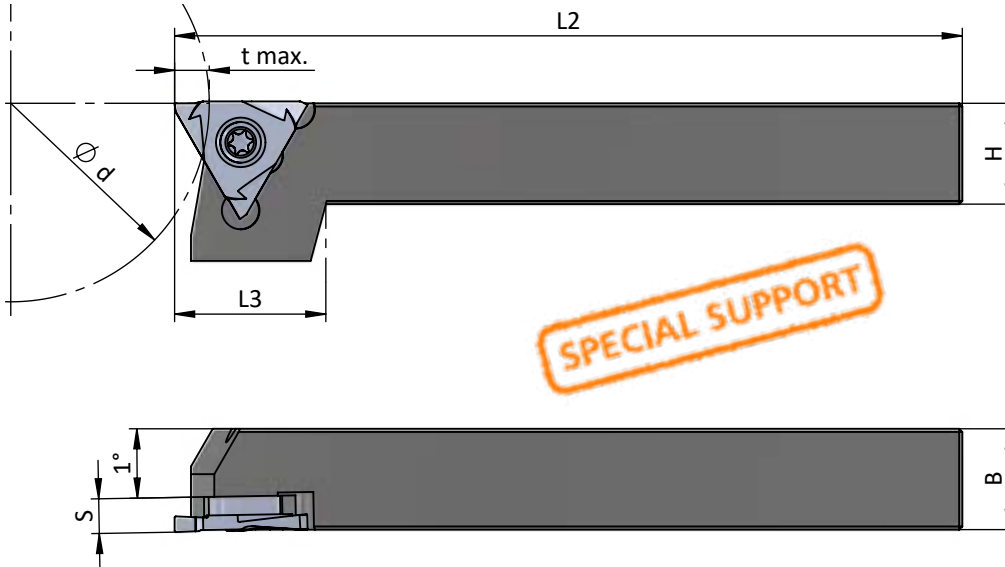

Beispielzeichnung
exemplary application

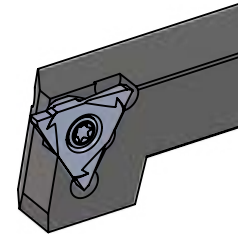

Rechts (R): wie gezeichnet
Links (L): spiegelbildlich

righthand (R): as shown
lefthand version (L): mirror image

Abmessungen in mm

dimensions in mm

Bestellnummer part number	H	B	*t max.	L2	L3	S	Spannschraube screw	Schraubenschlüssel wrench	Anzugs- drehmoment torque	für Wende- schneidplatte indexable insert
R/L .208.1616.S5-D	16	16	5.5	125	24	5.5				
R/L .208.2020.S5-D	20	20	5.5	125	24	5.5	A.SPS011	T20F-P	6.0 Nm	

*tmax. reduziert bei Werkstück Ø > 63
*tmax. reduced for workpiece Ø > 63

SYSTEM DED

Einstecken mit dreischneidigen Wendeplatten

grooving with three-cutting edges indexable inserts

Typ .619

Klemmhalter 45°, Axialeinstechen, Außenbearbeitung

toolholder 45°, face grooving, external application

Spannbereich S 3.3 mm

holding capacity S 3.3 mm

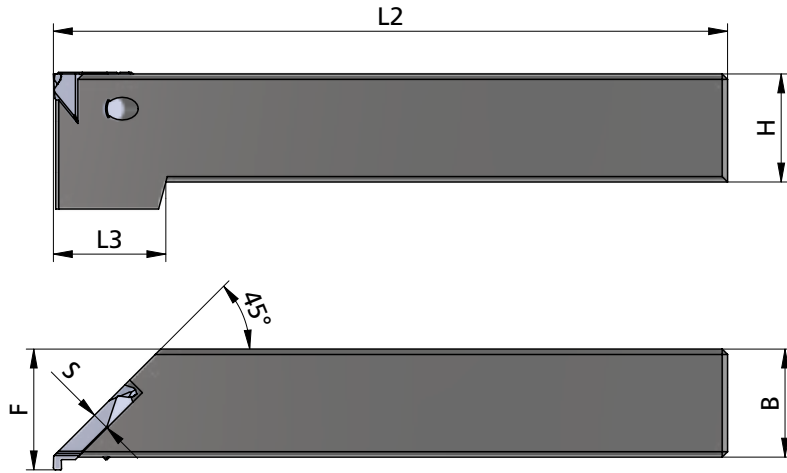

Beispielzeichnung
exemplary application

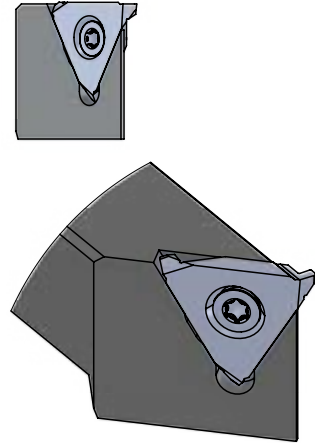

Linke Schneidpl. in rechtem Halter, wie gezeichnet

Rechte Schneidpl. in linkem Halter

Abmessungen in mm

LH insert in RH toolholder, as shown

RH insert in LH toolholder

dimensions in mm

Bestellnummer part number	H	B	L2	L3	F	S	Spannschraube screw	Schraubenschlüssel wrench	Anzugs- drehmoment torque	für Wende- schneidplatte indexable insert
R/L .619.1616.S3-D	16	16	100	21	18.3	3.3				
R/L .619.2020.S3-D	20	20	125	21	22.3	3.3	A.SPS009	TR20	6.0 Nm	R/L .DED45...
R/L .619.2525.S3-D	25	25	150	-	27.3	3.3				



Bestellbeispiel:
für rechte Ausführung
R.619.1616.S3-D

order-example:
righthand version
R.619.1616.S3-D

SYSTEM DED

Einstecken mit dreischneidigen Wendeplatten

grooving with three-cutting edges indexable inserts

Typ Stechdrehen

Wendeschneidplatte, Axialeinstechen, eingebaut unter 45°

indexable insert, face grooving, mounted in a 45° toolholder

D min. 8.0 mm
Stechtiefe t max. 2.0 mm
Stechbreite C 1.5 - 2.4 mm

D min. 8.0 mm
depth of groove t max. 2.0 mm
width of groove C 1.5 - 2.4 mm

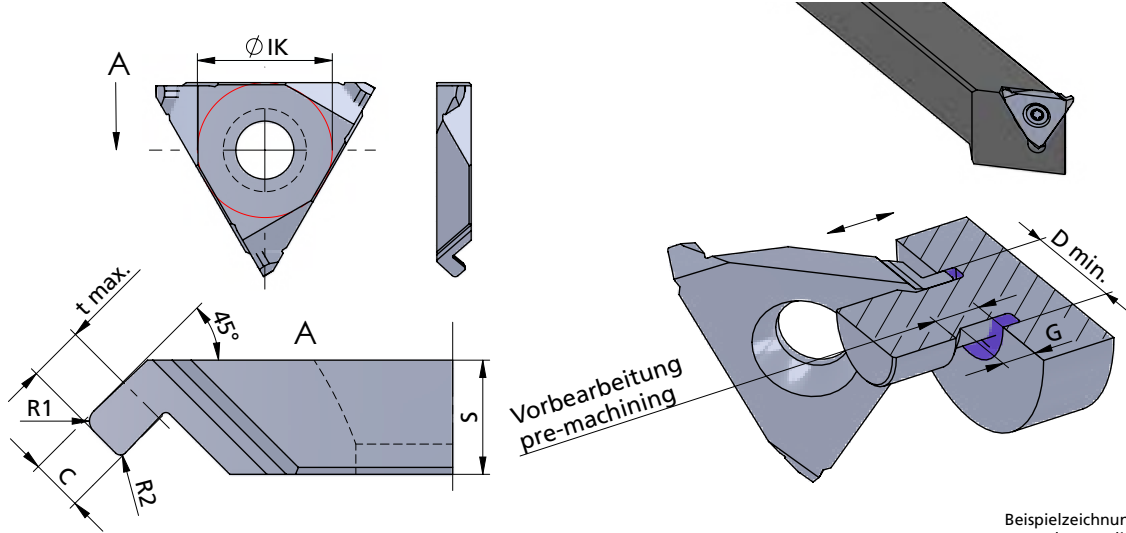

Beispielzeichnung
exemplary application

Linke Schneidpl. in rechtem Halter, wie gezeichnet

Rechte Schneidpl. in linkem Halter

Abmessungen in mm

LH insert in RH toolholder, as shown

RH insert in LH toolholder

dimensions in mm

Bestellnummer
part number

C

S

R1

R2

D min.

t max.

Ø IK

≥ G

K10F

CN45F

AL41F

P07C

Klemmhalter Typ

toolholder type

R/L .DED45.08152

1.5

3.3

0.2

0.2

8.0

1.6

13

2.7

●

R/L .DED45.08154

1.5

3.3

0.4

0.2

8.0

1.6

13

2.7

●

R/L .DED45.12202

2.0

3.3

0.2

0.2

12.0

2.0

13

2.7

●

R/L .DED45.12205

2.0

3.3

0.5

0.2

12.0

2.0

13

2.7

●

R/L .DED45.20246

2.4

3.3

0.6

0.2

20.0

2.0

13

2.7

●

R/L .619.S3-D

Weitere HM Sorten können Sie in der Sortenübersicht im Kapitel "Technische Hinweise" und der Preisliste finden.

Bestellbeispiel:
für Sorte AL41F:
L.DED45.08152

More carbide grades you can find in the grades summary in the chapter "technical instructions" and in the price list.

order-example:
grade AL41F:
L.DED45.08152

SYSTEM DED

Einstecken mit dreischneidigen Wendeplatten

grooving with three-cutting edges indexable inserts

Sets

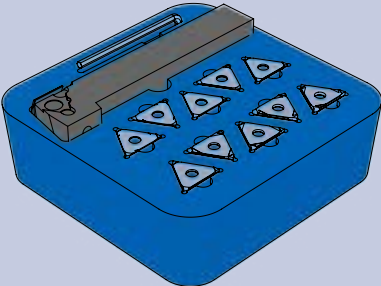
	Bestellnummer part number	Inhalt Content	K10F CN45F AL41F P07C
	<p>SET-DED 1</p> <ul style="list-style-type: none"> • Halter (rechte Ausführung) • für Sicherungsringe DIN 471 / 472 • und Stechdrehen allgemein Stechbreite S 0.57 - 1.99 <ul style="list-style-type: none"> • toolholder (right version) • for circlips DIN 471 / 472 • and general grooving width of groove S 0.57 - 1.99 	<p>Halter / toolholder: 1 x R.207.2020.1</p> <p>Schneideinsatz / insert:</p> <p>1 x DED.0050.00</p> <p>1 x DED.0060.00</p> <p>1 x DED.0070.00</p> <p>1 x DED.0080.00</p> <p>1 x DED.0090.00</p> <p>1 x DED.0100.00</p> <p>1 x DED.0110.00</p> <p>1 x DED.0130.00</p> <p>1 x DED.0160.00</p> <p>1 x DED.0185.00</p>	<p>•</p> <p>•</p> <p>•</p> <p>•</p> <p>•</p> <p>•</p> <p>•</p> <p>•</p> <p>•</p> <p>•</p>



Weitere Ausführungen auf Anfrage oder in der Preisliste.

Bestellbeispiel:
SET-DED 1

More versions on request and in the price list.

order-example:
SET-DED 1

SYSTEM D-GROOVING

Einstecken mit ein- oder zweischneidigen Schneideinsätzen

grooving with one- or two-cutting edges inserts

Allgemeine Beschreibung

Spangeometrien

general instruction cutting geometries

M1 - Medium cutting

P **K**

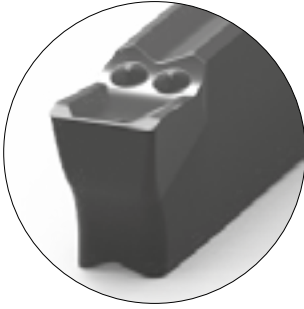

- Schneide mit schmaler, negativer Fase
- einsetzbar bei allen Stahlwerkstoffen mit hoher Festigkeit
- geeignet für alle Anwendungen
- für Stahl und Grauguss
- insert with narrow negative chamfer
- suitable for all steel materials with high strength
- suitable for all applications
- for steel and grey cast iron

Schneide / insert		
DZ24	DE24	DEK
✓	✓	✓

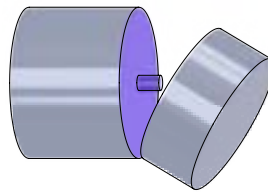

Abstechen / parting

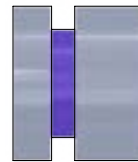

Einstecken / grooving

F1 - Sehr weicher Schnitt / Very soft cutting

P **M**

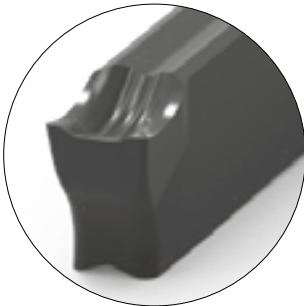

- ausgezeichneter Spanbrecher mit niedrigen Schnittkräften
- für alle Werkstoffe im niedrigen bis mittleren Festigkeitsbereich
- besonders geeignet zum Abtrennen von Rohre und dünnwandigen Werkstücken
- hohe Schneidkantenstabilität
- sehr gute Spankontrolle auch bei niedrigem Vorschub
- geringe Aufbauschneidenbildung
- excellent cutting chipbreaker with low cutting forces
- for low to medium strength materials
- particularly suitable for parting off tubes and thin-walled work pieces
- high cutting edge stability
- excellent chip control also with low feed
- low built up edge

Schneide / insert		
DZ24	DE24	DEK
✓	✓	-

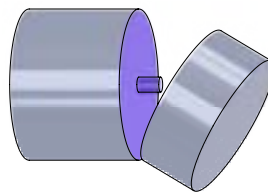

Abstechen / parting

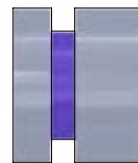

Einstecken / grooving

SYSTEM D-GROOVING

Einstecken mit ein- oder zweischneidigen Schneideinsätzen

grooving with one- or two-cutting edges inserts

Allgemeine Beschreibung

Spangeometrien

general instruction cutting geometries

S1 - Edelstahl und Superlegierungen / Stainless and super alloys **M S**



- Geometrie speziell für Edelstahl
- "Problemlöser" bei der Stahlzerspanung
- especially for stainless steel
- problem solver for steel machining

Schneide / insert		
DZ24	DE24	DEK
✓	✓	✓

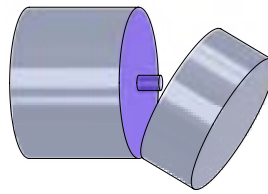

Abstechen / parting

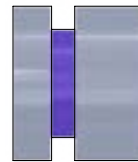

Einstecken / grooving

T1 - Einstecken und Längsdrehen / Grooving and turning **P M**

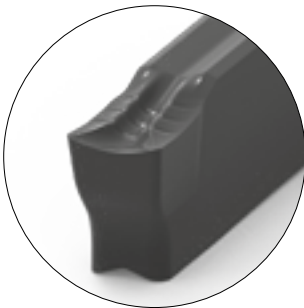

- zum Einstecken und Längsdrehen
- geeignet für alle Stähle und rostfreie Stähle
- sehr gute Spankontrolle
- for grooving and turning
- suitable for all steel and stainless steel materials
- very good chip control

Schneide / insert		
DZ24	DE24	DEK
✓	✓	-

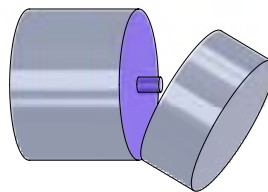

Abstechen / parting

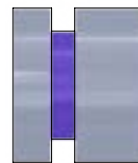

Einstecken / grooving

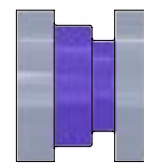

Längsdrehen / turning



SYSTEM D-GROOVING

Einstecken mit ein- oder zweischneidigen Schneideinsätzen

grooving with one- or two-cutting edges inserts

Allgemeine Beschreibung

Spangeometrien

general instruction cutting geometries

MV - Radius - Einstich / Radius grooves P K

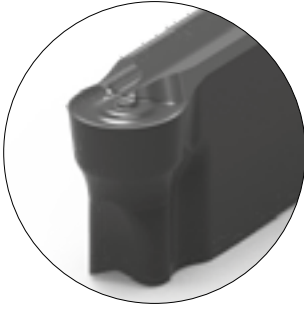

- Schneide für Radius-Einstich
- zum Kopierdrehen
- geeignet für alle Stähle und Gusseisen
- insert for radius grooves
- for copy turning
- suitable for all steel and cast iron materials

Schneide / insert		
DZ24	DE24	DEK
✓	-	-

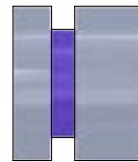

Einstecken / grooving

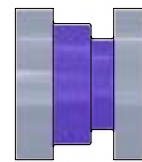

Längsdrehen / turning

LM - Nichteisenmetalle / Non ferrous metals N



- Schneide mit hochpositivem Spanbrecher und scharfer Schneidkante
- extraglatte Schneidgeometrie durch mikrofinish
- reduzierte Aufbaukante
- insert with highly positive cutting chipbreaker and sharp cutting edge
- extra-smooth rake face through "microfinish"
- reduced built-up edge

Schneide / insert		
DZ24	DE24	DEK
✓	✓	✓

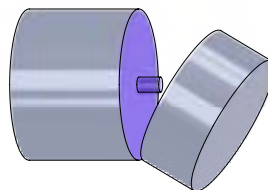

Abstechen / parting

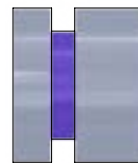

Einstecken / grooving

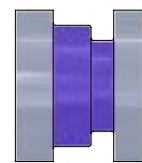

Längsdrehen / turning

SYSTEM D-GROOVING

Einstecken mit
ein- oder zweischneidigen
Schneideinsätzen

grooving with
one- or two-cutting edges
inserts

Allgemeine Beschreibung

Spangeometrien

general instruction
cutting geometries

M2 - Einstecken und Längsdrehen / Grooving and turning

P

K



- zum Einstecken und Längsdrehen
- geeignet für alle Stähle und Gusseisen
- sehr gute Spankontrolle
- for grooving and turning
- suitable for all steel and cast iron materials
- very good chip control

Schneide / insert		
DZ24	DE24	DEK
-	-	✓

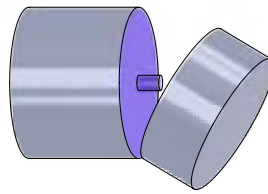

Abstechen / parting

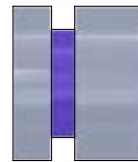

Einstecken / grooving

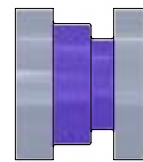

Längsdrehen / turning



SYSTEM D-GROOVING

Einstecken mit ein- oder zweischneidigen Schneideinsätzen

grooving with one- or two-cutting edges inserts

Typ DH

Klemmhalter, Außenbearbeitung

toolholder, external application

Stechtiefe t max. 13 mm
Spannbereich b 2.0 - 3.0 mm

depth of groove t max. 13 mm
holding capacity b 2.0 - 3.0 mm

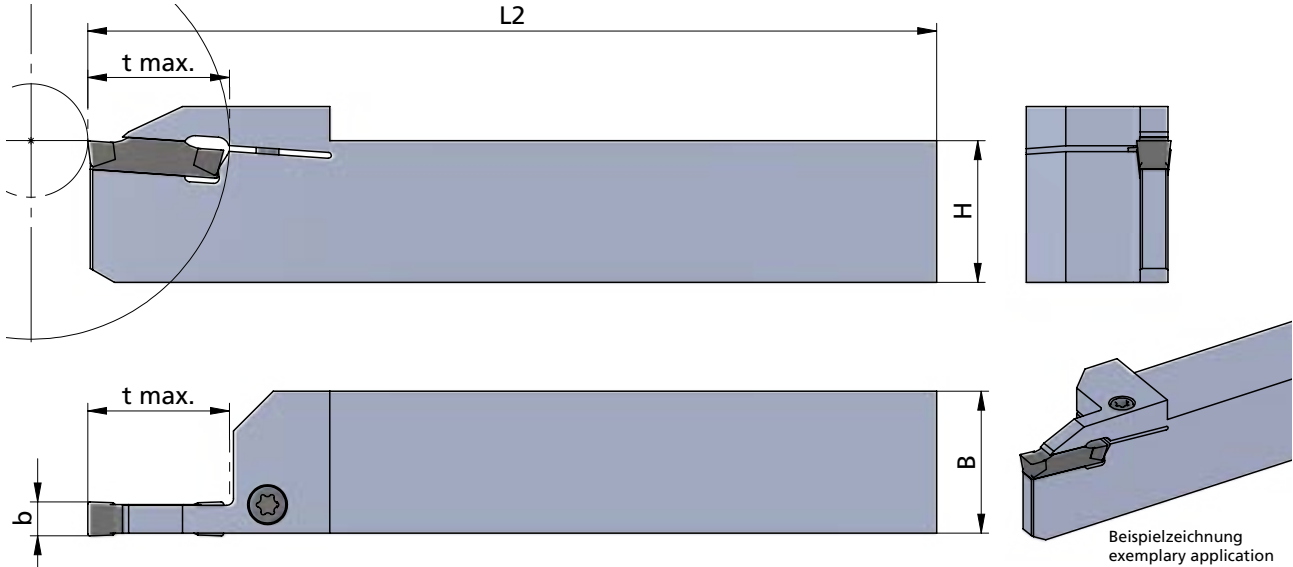

Rechts (R): wie gezeichnet
Links (L): spiegelbildlich

righthand (R): as shown
lefthand version (L): mirror image

Abmessungen in mm

dimensions in mm

Bestellnummer part number	H	B	t max.	L2	b	Spannschraube screw	Schraubenschlüssel wrench	Anzugsdrehmoment torque	Schneideinsatz	
									Typ	insert type
DHR. / DHL.122013.D24	12	12	13	125	2.0	A.SPS039	111.INB4	7.0 Nm	DZ24.R2 ... / DE24.R2 ...	
DHR. / DHL.162013.D24	16	16	13	125	2.0	A.SPS039	111.INB4	7.0 Nm	DZ24.L2 ... / DE24.L2 ...	
DHR. / DHL.202013.D24	20	20	13	125	2.0	A.SPS039	111.INB4	7.0 Nm	DZ24.N2 ... / DE24.N2 ...	
DHR. / DHL.123013.D24	12	12	13	125	3.0	A.SPS039	111.INB4	7.0 Nm		
DHR. / DHL.163013.D24	16	16	13	125	3.0	A.SPS039	111.INB4	7.0 Nm	DZ24.R3 ... / DE24.R3 ...	
DHR. / DHL.203013.D24	20	20	13	125	3.0	A.SPS039	111.INB4	7.0 Nm	DZ24.L3 ... / DE24.L3 ...	
DHR. / DHL.253013.D24	25	25	13	125	3.0	A.SPS040	111.INB5	7.0 Nm	DZ24.N3 ... / DE24.N3 ...	

SYSTEM D-GROOVING

Einstecken mit ein- oder zweischneidigen Schneideinsätzen

grooving with one- or two-cutting edges inserts

Typ DH

Klemmhalter, Außenbearbeitung

toolholder, external application

Stechtiefe t max. 25 mm
Spannbereich b 3.0 - 6.0 mm

depth of groove t max. 25 mm
holding capacity b 3.0 - 6.0 mm

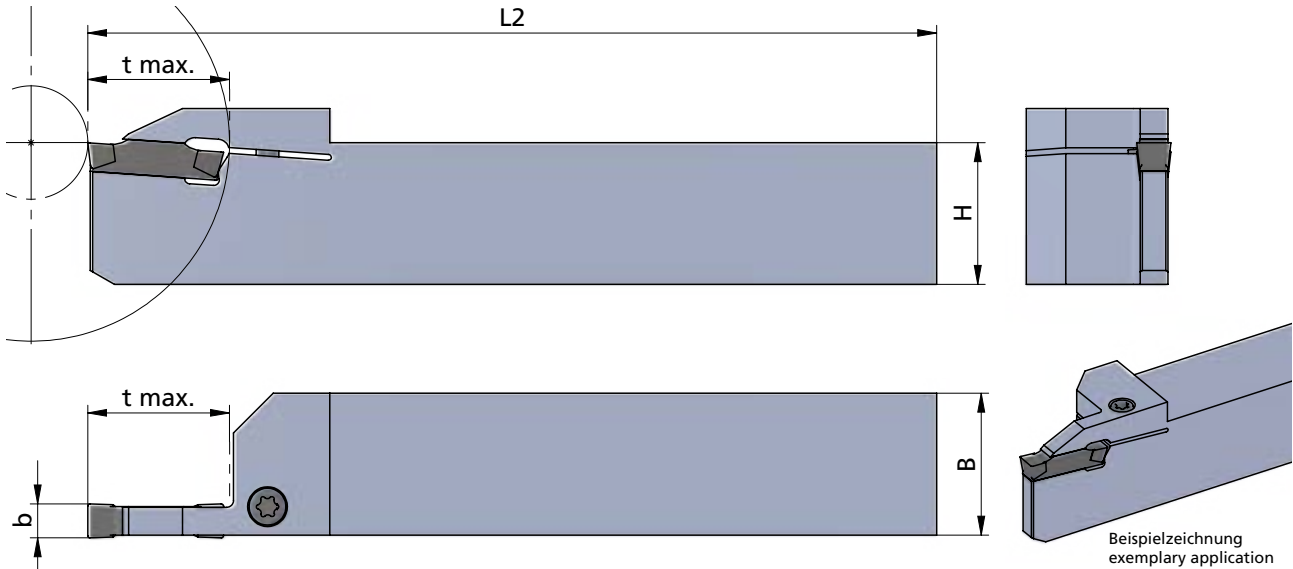

Rechts (R): wie gezeichnet
Links (L): spiegelbildlich

righthand (R): as shown
lefthand version (L): mirror image

Abmessungen in mm

dimensions in mm

Bestellnummer part number	H	B	t max. *	L2	b	Spannschraube screw	Schraubenschlüssel wrench	Anzugsdrehmoment torque	Schneideinsatz	
									Typ	insert type
DHR. / DHL.163025.D24	16	16	25	125	3.0	A.SPS039	111.INB4	7.0 Nm	DZ24.R3 ... / DE24.R3 ...	
DHR. / DHL.203025.D24	20	20	25	125	3.0	A.SPS039	111.INB4	7.0 Nm	DZ24.L3 ... / DE24.L3 ...	
DHR. / DHL.253025.D24	25	25	25	125	3.0	A.SPS040	111.INB5	7.0 Nm	DZ24.N3 ... / DE24.N3 ...	
DHR. / DHL.164025.D24	16	16	25	125	4.0	A.SPS039	111.INB4	7.0 Nm	DZ24.R4 ...	
DHR. / DHL.204025.D24	20	20	25	125	4.0	A.SPS039	111.INB4	7.0 Nm	DZ24.L4 ...	
DHR. / DHL.254025.D24	25	25	25	125	4.0	A.SPS040	111.INB5	7.0 Nm	DZ24.N4 ... / DE24.N4 ...	
DHR. / DHL.205025.D24	20	20	25	150	5.0	A.SPS039	111.INB4	7.0 Nm	DZ24.N5 ...	
DHR. / DHL.255025.D24	25	25	25	150	5.0	A.SPS040	111.INB5	7.0 Nm		
DHR. / DHL.206025.D24	20	20	25	150	6.0	A.SPS039	111.INB4	7.0 Nm		
DHR. / DHL.256025.D24	25	25	25	150	6.0	A.SPS040	111.INB5	7.0 Nm	DZ24.N6 ...	

Bestellbeispiel:
für rechte Ausführung
DHR.163025.D24

* Der Vorteil von DE24 - Schneideinsätzen ist die Möglichkeit, über die Länge der Platte hinaus, Nuten zu stechen, ohne die Oberflächen zu beschädigen.
the benefit of DE24 - inserts is the possibility to groove past the length of the insert without damaging the surface finish.

order-example:
righthand version
DHR.163025.D24



SYSTEM D-GROOVING

Einstecken mit ein- oder zweischneidigen Schneideinsätzen

grooving with one- or two-cutting edges inserts

Typ DH ... -IK

Klemhalter, mit Innenkühlung, Außenbearbeitung

toolholder, with internal cooling, external application

Stechtiefe t max. 13 / 25 mm
Spannbereich b 2.0 - 4.0 mm

depth of groove t max. 13 / 25 mm
holding capacity b 2.0 - 4.0 mm

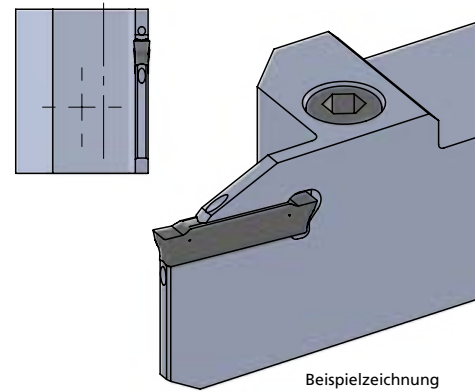
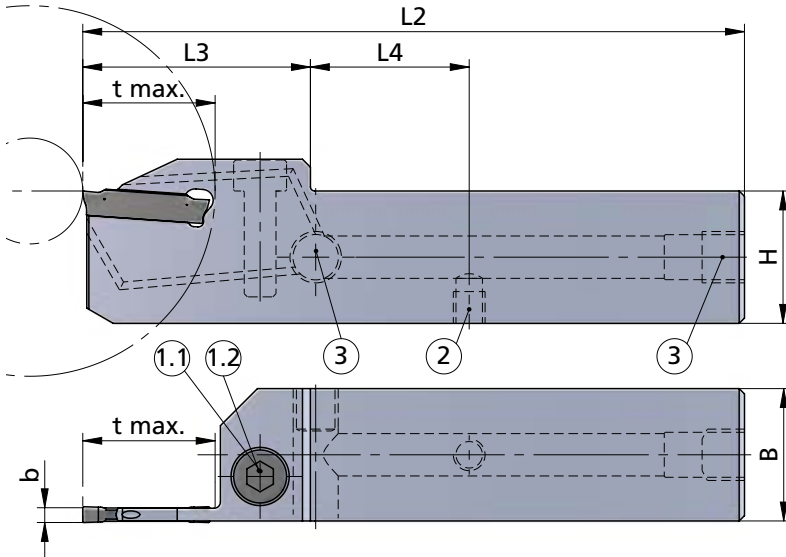

Beispielzeichnung
exemplary application

Rechts (R): wie gezeichnet
Links (L): spiegelbildlich

righthand (R): as shown
lefthand version (L): mirror image

Abmessungen in mm

dimensions in mm



Bestellnummer part number	H	B	t max.	L2	L3	L4	b	Pos. 1.1	Pos. 1.2	Pos. 2	Pos. 3	Schneideinsatz Typ insert type
								Schraube / screw A.SPS039	Schraube / screw A.SPS040	Schraube / screw M6.0/6.0/IS-DH	Schraube / screw G1/8/IS-DH	
DHR. / DHL.162013.D24- IK	16	16	13	125	43	30	2.0	●		●	●	DZ24.R2 ... / DE24.R2 ... DZ24.L2 ... / DE24.L2 ... DZ24.N2 ... / DE24.N2 ...
DHR. / DHL.202013.D24- IK	20	20	13	125	43	30	2.0	●		●	●	
DHR. / DHL.163025.D24- IK	16	16	25	125	43	30	3.0	●		●	●	DZ24.R3 ... / DE24.R3 ... DZ24.L3 ... / DE24.L3 ... DZ24.N3 ... / DE24.N3 ...
DHR. / DHL.203025.D24- IK	20	20	25	125	43	30	3.0	●		●	●	
DHR. / DHL.253025.D24- IK	25	25	25	125	43	30	3.0		●	●	●	
DHR. / DHL.164025.D24- IK	16	16	25	125	43	30	4.0	●		●	●	DZ24.R4 ... DZ24.L4 ... DZ24.N4 ... / DE24.N4 ...
DHR. / DHL.204025.D24- IK	20	20	25	125	43	30	4.0	●		●	●	
DHR. / DHL.254025.D24- IK	25	25	25	125	43	30	4.0		●	●	●	

Position	Schraube / screw	Schraubenschlüssel / wrench	Anzugsdrehmoment / torque
1.1	A.SPS039	111.INB4	7.0 Nm
1.2	A.SPS040	111.INB5	7.0 Nm
2	M6.0/6.0/IS-DH	111.INB3	-
3	G1/8/IS-DH	-	-

SYSTEM D-GROOVING

Einstecken mit ein- oder zweischneidigen Schneideinsätzen

grooving with one- or two-cutting edges inserts

Typ DS

Klemmhalter; Swisstype Außenbearbeitung

toolholder; Swisstype external application

Stechtiefe t max. 13 / 21 mm
Spannbereich b 2.0 / 3.0 mm

depth of groove t max. 13 / 21 mm
holding capacity b 2.0 / 3.0 mm

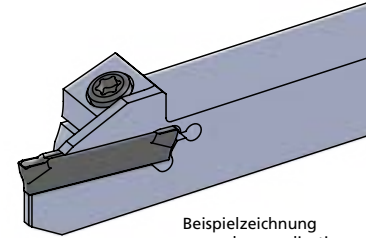
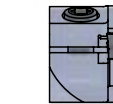
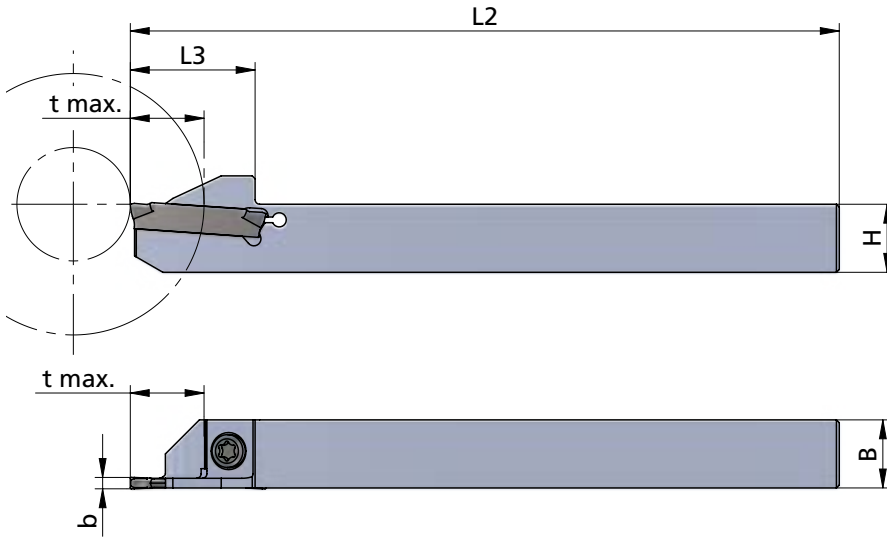

Rechts (R): wie gezeichnet
Links (L): spiegelbildlich

righthand (R): as shown
lefthand version (L): mirror image

Abmessungen in mm

dimensions in mm

Bestellnummer part number	H	B	t max.	L2	L3	b	Spannschraube screw	Schraubenschlüssel wrench	Anzugsdrehmoment torque	Schneideinsatz	
										Typ	insert type
DSR. / DSL.122013.D24	12	12	13	125	22	2.0	A.SPS031	A.SSL002	4 Nm	DZ24.R2 ... / DE24.R2 ... DZ24.L2 ... / DE24.L2 ... DZ24.N2 ... / DE24.N2 ...	
DSR. / DSL.122021.D24	12	12	21	125	30	2.0					
DSR. / DSL.162013.D24	16	16	13	125	22	2.0					
DSR. / DSL.162021.D24	16	16	21	125	30	2.0				DZ24.R3 ... / DE24.R3 ... DZ24.L3 ... / DE24.L3 ... DZ24.N3 ... / DE24.N3 ...	
DSR. / DSL.123013.D24	12	12	13	125	22	3.0					
DSR. / DSL.123021.D24	12	12	21	125	30	3.0					
DSR. / DSL.163013.D24	16	16	13	125	22	3.0					
DSR. / DSL.163021.D24	16	16	21	125	30	3.0					



Bestellbeispiel:
für rechte Ausführung
DSR.122013.D24

order-example:
righthand version
DSR.122013.D24

SYSTEM D-GROOVING

Einstecken mit ein- oder zweischneidigen Schneideinsätzen

grooving with one- or two-cutting edges inserts

Typ DS ... -IK

Klemmhalter; Swisstype mit Innenkühlung, Außenbearbeitung

toolholder; Swisstype with internal cooling, external application

Stechtiefe t max. 13 / 21 mm
Spannbereich b 2.0 / 3.0 mm

depth of groove t max. 13 / 21 mm
holding capacity b 2.0 / 3.0 mm

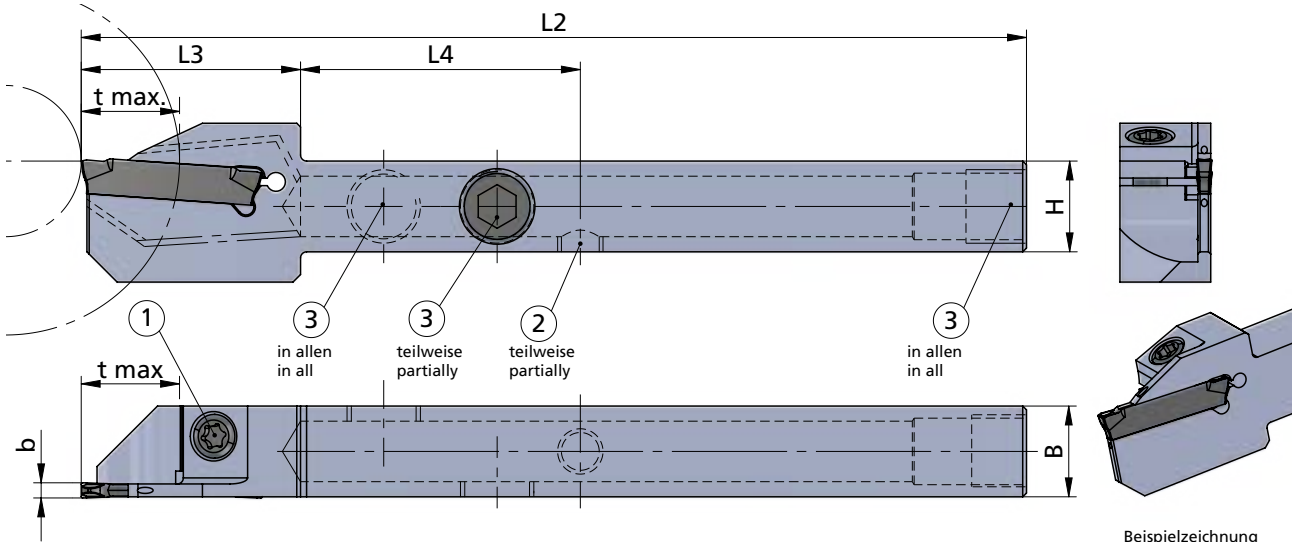

Beispielzeichnung
exemplary application

Rechts (R): wie gezeichnet
Links (L): spiegelbildlich

righthand (R): as shown
lefthand version (L): mirror image

Abmessungen in mm

dimensions in mm



Bestellnummer part number	H	B	t max.	L2	L3	L4	b	Pos.1			Pos.2		Pos.3	Schneideinsatz Typ insert type
								Schraube / screw A.SP5031	Schraubenschlüssel wrench	Anzugsdrehmoment / torque 4,0 Nm	Schraube / screw M6.0/6.0/IS-DH	Schraubenschlüssel wrench	111.INB3	
DSR. / DSL.122013.D24- IK	12	12	13	125	29	-	2.0	●					○	DZ24.R2 ... / DE24.R2 ...
DSR. / DSL.162013.D24- IK	16	16	13	125	29	44	2.0	●					○	DZ24.L2 ... / DE24.L2 ...
DSR. / DSL.162021.D24- IK	16	16	21	125	36	37	2.0	●			●		○	DZ24.N2 ... / DE24.N2 ...
DSR. / DSL.123013.D24- IK	12	12	13	125	29	-	3.0	●					○	DZ24.R3 ... / DE24.R3 ...
DSR. / DSL.163013.D24- IK	16	16	13	125	29	44	3.0	●					○	DZ24.L3 ... / DE24.L3 ...
DSR. / DSL.163021.D24- IK	16	16	21	125	36	37	3.0	●			●		○	DZ24.N3 ... / DE24.N3 ...

SYSTEM D-GROOVING

Einstecken mit ein- oder zweischneidigen Schneideinsätzen

grooving with one- or two-cutting edges inserts

Typ DI...D24-IK

Bohrstange mit Innenkühlung, Innenbearbeitung

grooving boring bar with internal cooling, internal application

D min. 32 mm
Stechtiefe t max. 12 mm
Spannbereich b 2.0 - 5.0 mm

D min. 32 mm
depth of groove t max. 12 mm
holding capacity b 2.0 - 5.0 mm

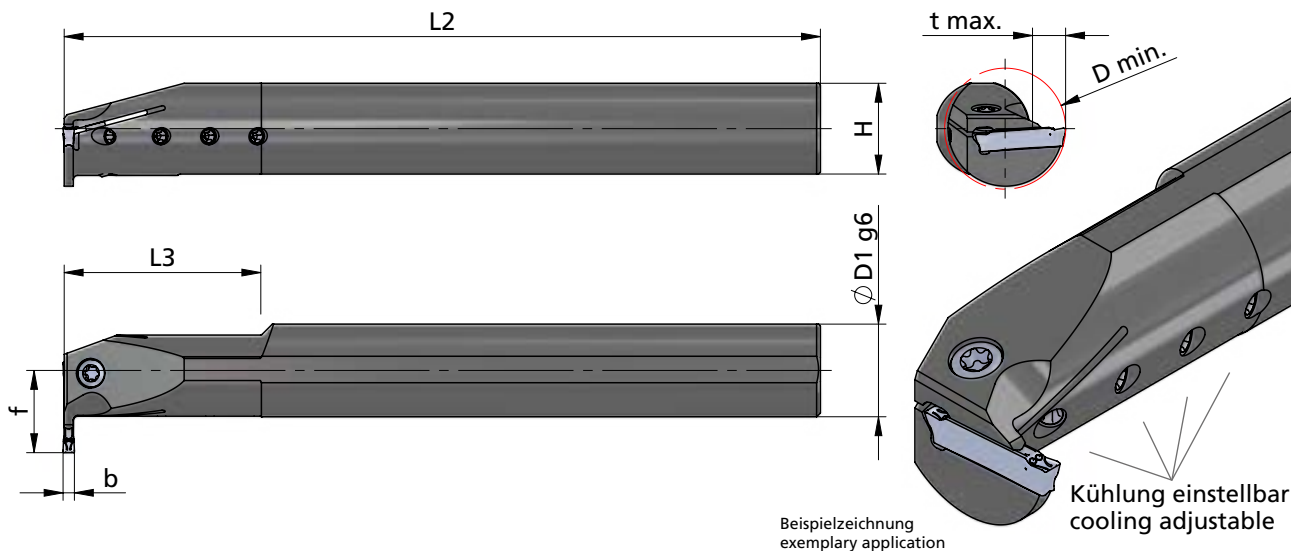

Rechts (R): wie gezeichnet
Links (L): spiegelbildlich

righthand (R): as shown
lefthand version (L): mirror image



Abmessungen in mm

dimensions in mm

Bestellnummer part number	b	Ø D1 g6	H	f	D min.	t max.	L2	L3	Spannschraube screw	Schrauben- schlüssel wrench	Anzugs- drehmoment torque	Schneideinsatz Typ insert type
DIR. / DIL.252008.D24-IK	2	25	24.0	21	32	8	200	52	M5.0/18-DI	T20F	5.0 Nm	DZ24.R2 ... / DE24.R2 ... DZ24.L2 ... / DE24.L2 ... DZ24.N2 ... / DE24.N2 ...
DIR. / DIL.253009.D24-IK	3	25	24.0	22	32	9	200	52				DZ24.R3 ... / DE24.R3 ...
DIR. / DIL.323011.D24-IK	3	32	30.0	27.5	42	11	250	64				DZ24.L3 ... / DE24.L3 ...
DIR. / DIL.324011.D24-IK	4	32	30.0	27.5	42	11	250	64				DZ24.N3 ... / DE24.N3 ...
DIR. / DIL.404012.D24-IK	4	40	37.0	32.5	53	12	300	80				DZ24.R4 ... DZ24.L4 ... DZ24.N4 ... / DE24.N4 ...
DIR. / DIL.405012.D24-IK	5	40	37.0	32.5	53	12	300	80		DZ24.N5 ...		

Bestellbeispiel:
für rechte Ausführung
DIR.252008.D24-IK

order-example:
righthand version
DIR.252008.D24-IK

SYSTEM D-GROOVING

Einstecken mit ein- oder zweischneidigen Schneideinsätzen

grooving with one- or two-cutting edges inserts

Typ SBD. ...

Spannblock, Einsatz mit Klinge, Außenbearbeitung

clamping block, usable with blade, external application

Klinge H = 26 / 32 mm

blade H = 26 / 32 mm

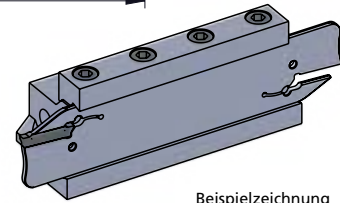
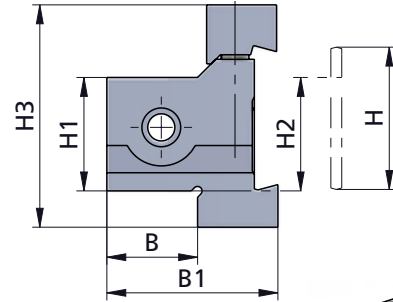
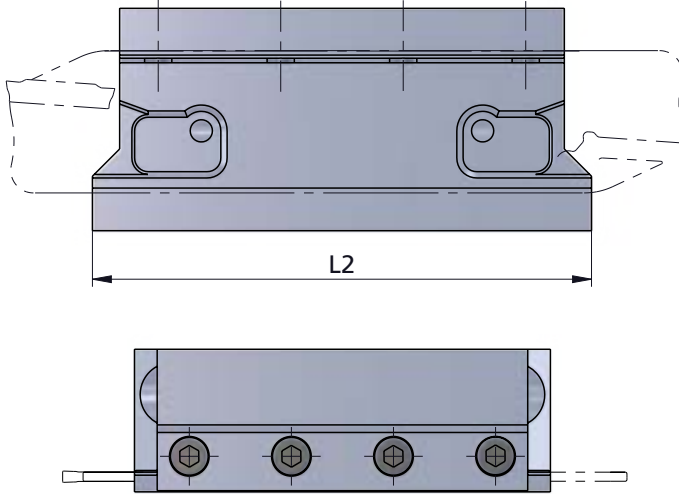

Beispielzeichnung
exemplary application

Abmessungen in mm

dimensions in mm

Bestellnummer part number	H	H1	H2	H3	L2	B	B1	Spannschraube screw	Schraubenschlüssel wrench	Anzugsdrehmoment torque	Klinge Typ	blade type
SBD.26.20	26	20	20	43	90	20	37	M6.0/25-SBD	111.INB5	7.0 Nm	DKR.26 ...D24 / DKR.26DEK	DKL.26 ...D24 / DKL.26DEK
											DKN.26 ...D24 / DKN.26DEK	
											DKR.32 ...D24 / DKR.32DEK	DKL.32 ...D24 / DKL.32DEK
SBD.32.25	32	25	25	49	110	20	38				DKN.32 ...D24 / DKN.32DEK	

SYSTEM D-GROOVING

Einstecken mit ein- oder zweischneidigen Schneideinsätzen

grooving with one- or two-cutting edges inserts

Typ SBD. ... -IK

Spannblock, Einsatz mit Klinge, mit Innenkühlung, Außenbearbeitung

Klinge H = 26 / 32 mm

clamping block, usable with blade, with internal cooling, external application

blade H = 26 / 32 mm

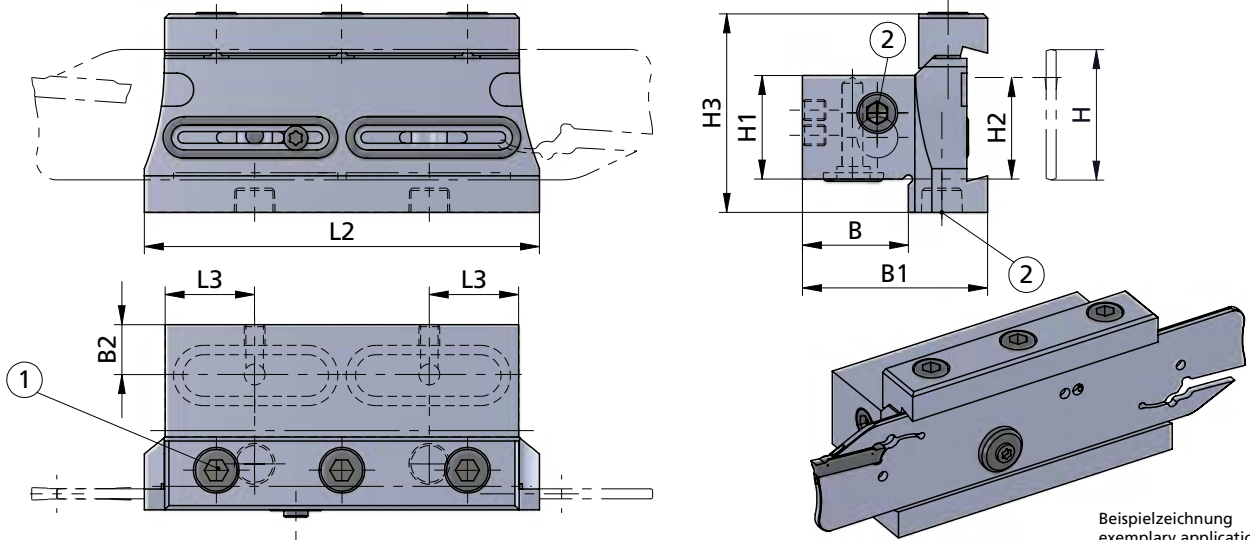

Beispielzeichnung
exemplary application

Abmessungen in mm

dimensions in mm

Bestellnummer part number	H	H1	H2	H3	L2	L3	B	B1	B2	Position	Schraube screw	Schrauben- schlüssel wrench	Anzugs- drehmoment torque	Klinge Typ blade type	
SBD.26.20- IK	26	20	20	43	82	19	20	40	10	1	M6.0/12-SBD	111.INB5	7 Nm	DKR.26 ...D24- IK / DKR.26DEK- IK	DKL.26 ...D24- IK / DKL.26DEK- IK
														DKN.26 ...D24- IK / DKN.26DEK- IK	
SBD.32.25- IK	32	25	25	49	95	21	25	44.5	12.5	2	G1/8/IS-DH	-	DKR.32 ...D24- IK / DKR.32DEK- IK	DKL.32 ...D24- IK / DKL.32DEK- IK	
													DKN.32 ...D24- IK / DKN.32DEK- IK		

Bestellbeispiel:
SBD.26.20-**IK**

order-example:
SBD.26.20-**IK**

SYSTEM D-GROOVING

Einstecken mit ein- oder zweischneidigen Schneideinsätzen

grooving with one- or two-cutting edges inserts

Typ DKD24

Klinge, für Schneideinsatz DZ24 / DE24

blade, for insert DZ24 / DE24

Stechtiefe t max. 50 mm
Stechbreite b 2.0 - 4.0 mm

depth of groove t max. 50 mm
width of groove b 2.0 - 4.0 mm

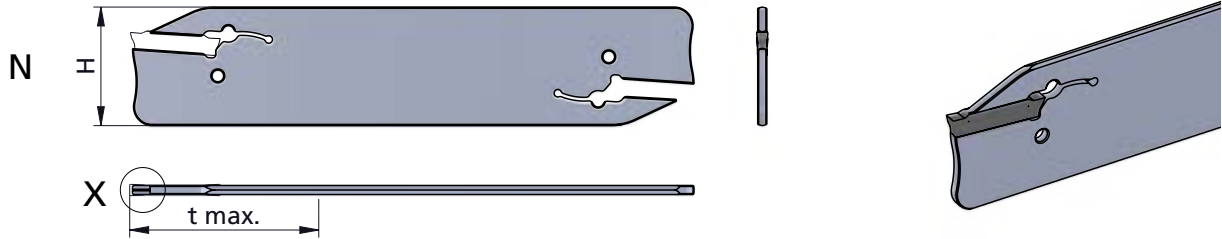

Ausrichtung Klinge
alignment blade

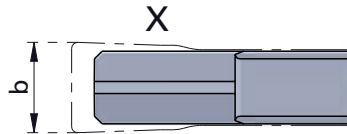
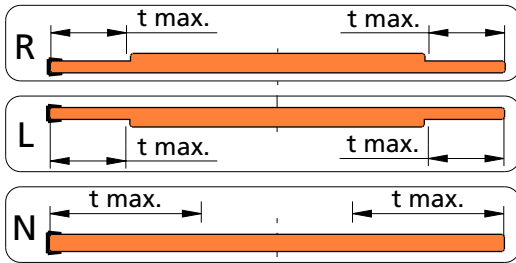

Beispielzeichnung
exemplary application

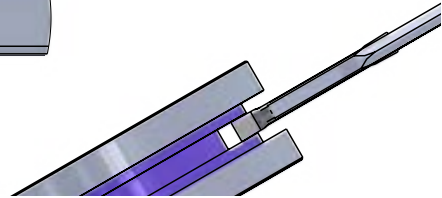

Neutral (N): wie gezeichnet

Neutral (N): as shown

Abmessungen in mm

dimensions in mm

Bestellnummer part number	Stechbreite b width of groove b	H	t max.	Ausrichtung Schneide alignment cutting edge	Montageschlüssel * assembly key *	Schneideinsatz Typ insert type	Spannblock Typ clamping block type
DKR.262025.D24	2.0	26	25	R		DZ24.R2 ... / DE24.R2 ...	
DKL.262025.D24	2.0	26	25	L	S-DK-2-3	DZ24.L2 ... / DE24.L2 ...	SBD.26.20
DKN.262025.D24	2.0	26	25	N		DZ24.N2 ... / DE24.N2 ...	
					S-DK-2-3	DZ24.R3 ... / DE24.R3 ... DZ24.L3 ... / DE24.L3 ...	SBD.26.20
DKN.263035.D24	3.0	26	35	N		DZ24.N3 ... / DE24.N3 ...	
					S-DK-4-6	DZ24.R4 ... DZ24.L4 ...	SBD.26.20
DKN.264035.D24	4.0	26	35	N		DZ24.N4 ... / DE24.N4 ...	
↳ ...							

* Montageschlüssel ist nicht im Lieferumfang enthalten und muss separat bestellt werden.

* Montageschlüssel / assembly key

* Assembly key is not included in the scope of delivery and must be ordered separately.



SYSTEM D-GROOVING

Einstecken mit ein- oder zweischneidigen Schneideinsätzen

grooving with one- or two-cutting edges inserts

Typ DKD24

Klinge, für Schneideinsatz DZ24 / DE24

blade, for insert DZ24 / DE24

Stechtiefe t max. 50 mm
Stechbreite b 2.0 - 4.0 mm

depth of groove t max. 50 mm
width of groove b 2.0 - 4.0 mm

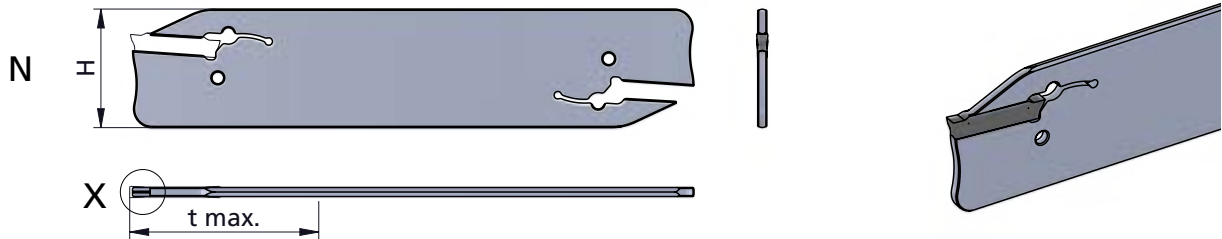

Ausrichtung Klinge
alignment blade

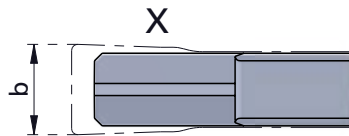
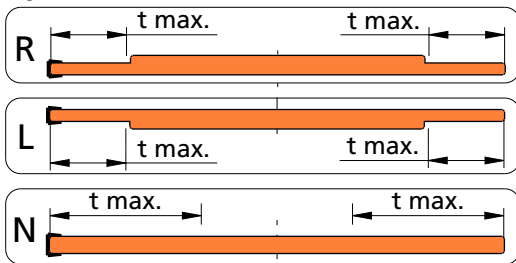

Beispielzeichnung
exemplary application

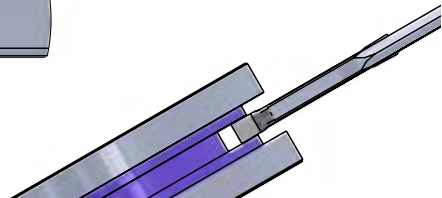

Neutral (N): wie gezeichnet

Neutral (N): as shown

Abmessungen in mm

dimensions in mm

Bestellnummer part number	Stechbreite b width of groove b	H	t max.	Ausrichtung Schneide alignment cutting edge	Montageschlüssel * assembly key *	Schneideinsatz Typ insert type	Spannblock Typ clamping block type
DKR.322025.D24	2.0	32	25	R		DZ24.R2 ... / DE24.R2 ...	
DKL.322025.D24	2.0	32	25	L	S-DK-2-3	DZ24.L2 ... / DE24.L2 ...	SBD.32.25
DKN.322025.D24	2.0	32	25	N		DZ24.N2 ... / DE24.N2 ...	
					S-DK-2-3	DZ24.R3 ... / DE24.R3 ... DZ24.L3 ... / DE24.L3 ...	SBD.32.25
DKN.323050.D24	3.0	32	50	N		DZ24.N3 ... / DE24.N3 ...	
					S-DK-4-6	DZ24.R4 ... DZ24.L4 ...	SBD.32.25
DKN.324050.D24	4.0	32	50	N		DZ24.N4 ... / DE24.N4 ...	

* Montageschlüssel ist nicht im Lieferumfang enthalten und muss separat bestellt werden.

* Montageschlüssel / assembly key

* Assembly key is not included in the scope of delivery and must be ordered separately.

Bestellbeispiel:
für rechte Ausführung
DKR.322025.D24 + S-DK-2-3



order-example:
righthand version
DKR.322025.D24 + S-DK-2-3

SYSTEM D-GROOVING

Einstecken mit ein- oder zweischneidigen Schneideinsätzen

grooving with one- or two-cutting edges inserts

Typ DKD24-IK

Klinge, mit Innenkühlung für Schneideinsatz DZ24 / DE24

blade, with internal cooling for insert DZ24 / DE24

Stechtiefe t max. 50 mm
Stechbreite b 2.0 - 4.0 mm

depth of groove t max. 50 mm
width of groove b 2.0 - 4.0 mm

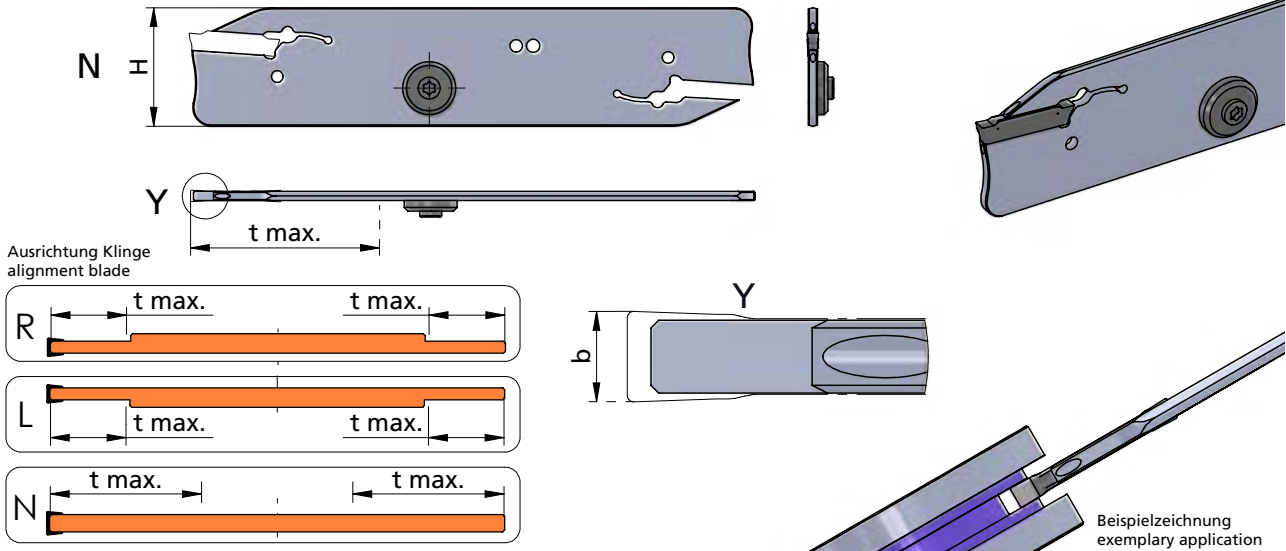

Ausrichtung Klinge
alignment blade

Beispielzeichnung
exemplary application

Neutral (N): wie gezeichnet

Neutral (N): as shown

Abmessungen in mm

dimensions in mm

Bestellnummer part number	Stechbreite b width of groove b	H	t max.	Ausrichtung Schneide alignment cutting edge	Montageschlüssel * assembly key *	Verschlussschraube coolant screw	Schrauben- schlüssel wrench	Schneideinsatz Typ insert type	Spannblock Typ clamping block type
DKR.262025.D24-IK	2.0	26	25	R	S-DK-2-3	DS-M4/3-IK	T15F	DZ24.R2 ... / DE24.R2 ...	SBD.26.20-IK
DKL.262025.D24-IK	2.0	26	25	L					
DKN.262025.D24-IK	2.0	26	25	N					
DKN.263035.D24-IK	3.0	26	35	N	S-DK-2-3			DZ24.R3 ... / DE24.R3 ...	SBD.26.20-IK
								DZ24.L3 ... / DE24.L3 ...	
								DZ24.N3 ... / DE24.N3 ...	
DKN.264035.D24-IK	4.0	26	35	N	S-DK-4-6	DZ24.R4 ...	SBD.26.20-IK		
						DZ24.L4 ...			
							DZ24.N4 ... / DE24.N4 ...		

↳ ...

* Montageschlüssel ist nicht im Lieferumfang enthalten und muss separat bestellt werden.

* Montageschlüssel / assembly key

* Assembly key is not included in the scope of delivery and must be ordered separately.



Bestellbeispiel:
für rechte Ausführung
DKR.262025.D24-IK + S-DK-2-3

order-example:
righthand version
DKR.262025.D24-IK + S-DK-2-3

SYSTEM D-GROOVING

Einstecken mit ein- oder zweischneidigen Schneideinsätzen

grooving with one- or two-cutting edges inserts

Typ DKD24-IK

Klinge, mit Innenkühlung für Schneideinsatz DZ24 / DE24

blade, with internal cooling for insert DZ24 / DE24

Stechtiefe t max. 50 mm
Stechbreite b 2.0 - 4.0 mm

depth of groove t max. 50 mm
width of groove b 2.0 - 4.0 mm

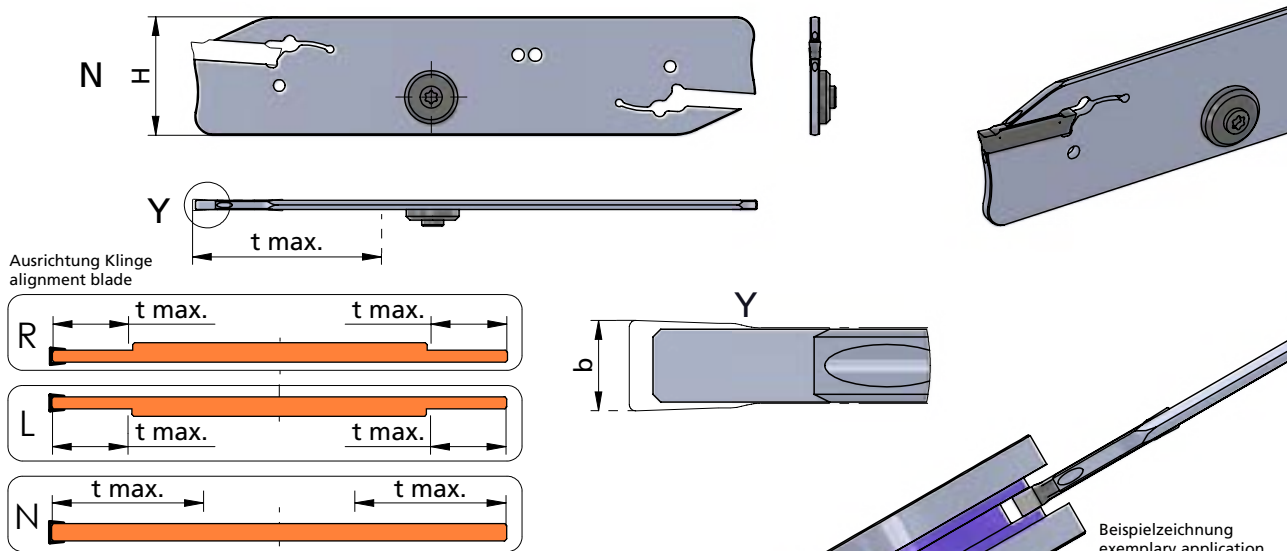

Neutral (N): wie gezeichnet
Abmessungen in mm

Neutral (N): as shown
dimensions in mm



Bestellnummer part number	Stechbreite b width of groove b	H	t max.	Ausrichtung Schneide alignment cutting edge	Montageschlüssel * assembly key *	Verschlussschraube coolant screw	Schrauben- schlüssel wrench	Schneideinsatz Typ	insert type	Spannblock Typ clamping block type
DKR.322025.D24-IK	2.0	32	25	R	S-DK-2-3	DS-M4/3-IK	T15F	DZ24.R2 ... / DE24.R2 ...		SBD.32.25-IK
DKL.322025.D24-IK	2.0	32	25	L				DZ24.L2 ... / DE24.L2 ...		
DKN.322025.D24-IK	2.0	32	25	N				DZ24.N2 ... / DE24.N2 ...		
DKN.323050.D24-IK	3.0	32	50	N	S-DK-2-3			DZ24.R3 ... / DE24.R3 ...		SBD.32.25-IK
								DZ24.L3 ... / DE24.L3 ...		
DKN.324050.D24-IK	4.0	32	50	N	S-DK-4-6			DZ24.N3 ... / DE24.N3 ...		SBD.32.25-IK
								DZ24.R4 ...		
								DZ24.L4 ...		
								DZ24.N4 ... / DE24.N4 ...		

* Montageschlüssel ist nicht im Lieferumfang enthalten und muss separat bestellt werden.
Bestellbeispiel:
für rechte Ausführung
DKR.322025.D24-IK + S-DK-2-3



* Assembly key is not included in the scope of delivery and must be ordered separately.
order-example:
righthand version
DKR.322025.D24-IK + S-DK-2-3



SYSTEM D-GROOVING

Einstecken mit ein- oder zweischneidigen Schneideinsätzen

grooving with one- or two-cutting edges inserts

Typ DKDEK

Klinge, für Schneideinsatz DEK

blade, for insert DEK

Stechtiefe t max. 50 mm
Stechbreite b 2.0 - 4.0 mm

depth of groove t max. 50 mm
width of groove b 2.0 - 4.0 mm

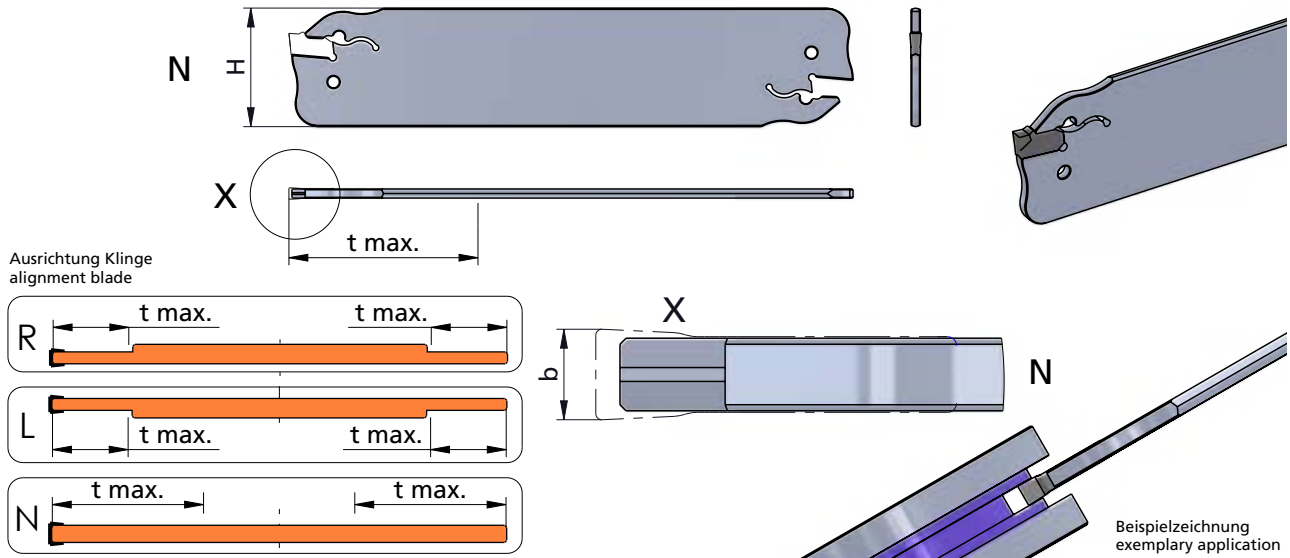

Ausrichtung Klinge
alignment blade

Beispielzeichnung
exemplary application

Neutral (N): wie gezeichnet

Neutral (N): as shown

Abmessungen in mm

dimensions in mm

Bestellnummer part number	Stechbreite b width of groove b	H	t max.	Ausrichtung Schneide alignment cutting edge	Montageschlüssel * assembly key *	Schneideinsatz Typ insert type	Spannblock Typ clamping block type
DKR.262025.DEK	2.0	26	25	R			
DKL.262025.DEK	2.0	26	25	L	S-DK-2-3	DEK.N2 ...	SBD.26.20
DKN.263035.DEK	3.0	26	35	N	S-DK-2-3	DEK.N3 ...	SBD.26.20
DKN.264040.DEK	4.0	26	40	N	S-DK-4-6	DEK.N4 ...	SBD.26.20
↳ ...							

* Montageschlüssel ist nicht im Lieferumfang enthalten und muss separat bestellt werden.

* Montageschlüssel / assembly key

* Assembly key is not included in the scope of delivery and must be ordered separately.



Bestellbeispiel:
für rechte Ausführung
DKR.262025.DEK + S-DK-2-3

order-example:
righthand version
DKR.262025.DEK + S-DK-2-3

SYSTEM D-GROOVING

Einstecken mit ein- oder zweischneidigen Schneideinsätzen

grooving with one- or two-cutting edges inserts

Typ DKDEK

Klinge, für Wendeschneidplatte DEK

blade, for indexable insert DEK

Stechtiefe t max. 50 mm
Stechbreite b 2.0 - 4.0 mm

depth of groove t max. 50 mm
width of groove b 2.0 - 4.0 mm

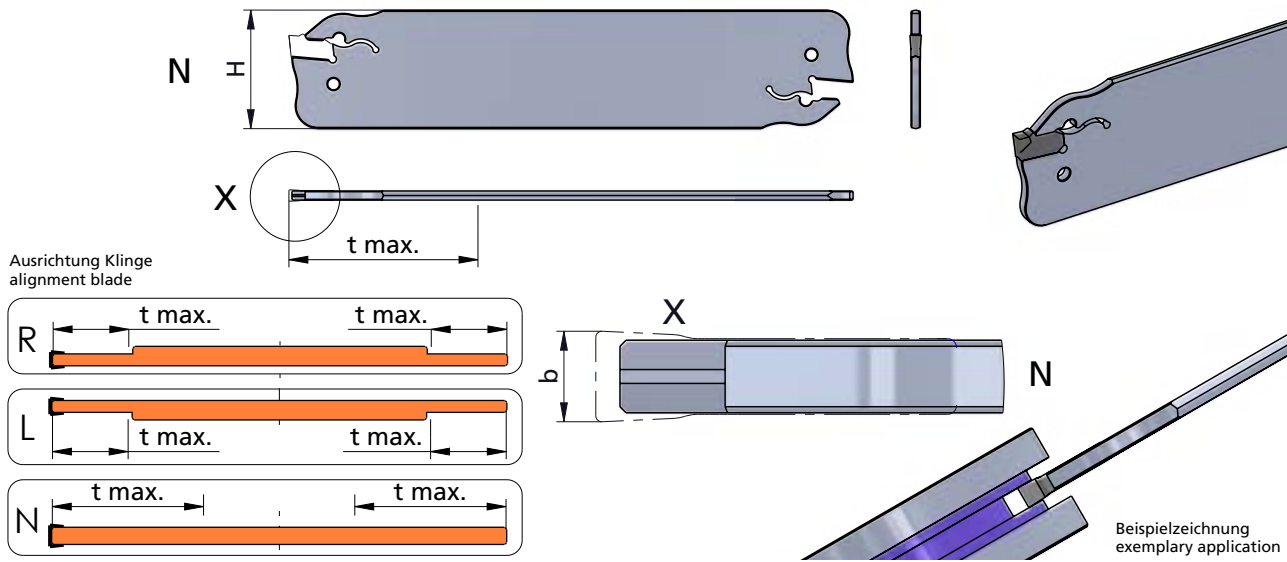

Ausrichtung Klinge alignment blade
Neutral (N): wie gezeichnet
Abmessungen in mm

Neutral (N): as shown
dimensions in mm
Beispielzeichnung exemplary application

Bestellnummer part number	Stechbreite b width of groove b	H	t max.	Ausrichtung Schneide alignment cutting edge	Montageschlüssel * assembly key *	Schneideinsatz Typ insert type	Spannblock Typ clamping block type
DKR.322025.DEK	2.0	32	25	R			
DKL.322025.DEK	2.0	32	25	L	S-DK-2-3	DEK.N2 ...	SBD.32.25
DKN.323050.DEK	3.0	32	50	N	S-DK-2-3	DEK.N3 ...	SBD.32.25
DKN.324050.DEK	4.0	32	50	N	S-DK-4-6	DEK.N4 ...	SBD.32.25

* Montageschlüssel ist nicht im Lieferumfang enthalten und muss separat bestellt werden.
Bestellbeispiel:
für rechte Ausführung
DKR.322025.DEK + S-DK-2-3



* Assembly key is not included in the scope of delivery and must be ordered separately.
order-example:
righthand version
DKR.322025.DEK + S-DK-2-3

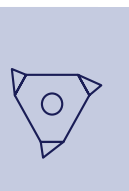

SYSTEM D-GROOVING

Einstecken mit ein- oder zweischneidigen Schneideinsätzen

grooving with one- or two-cutting edges inserts

Typ DKDEK-IK

Klinge, mit Innenkühlung, für Schneideinsatz DEK

blade, with internal cooling, for insert DEK

Stechtiefe t max. 50 mm
Stechbreite b 2.0 - 4.0 mm

depth of groove t max. 50 mm
width of groove b 2.0 - 4.0 mm

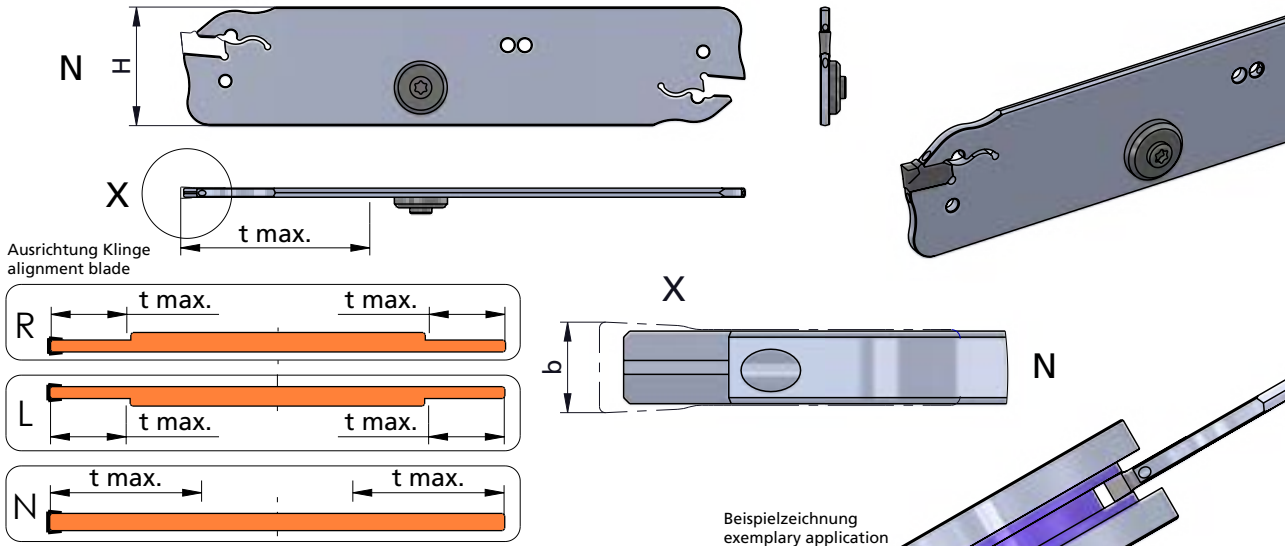

Neutral (N): wie gezeichnet

Neutral (N): as shown

Abmessungen in mm

dimensions in mm

Bestellnummer part number	Stechbreite b width of groove b	H	t max.	Ausrichtung Schneide alignment cutting edge	Montageschlüssel * assembly key *	Verschlusschraube coolant screw	Schrauben- schlüssel wrench	Schneideinsatz Typ insert type	Spannblock Typ clamping block type
DKR.262025.DEK-IK	2.0	26	25	R	S-DK-2-3	DS-M4/3-IK	T15F	DEK.N2 ...	SBD.26.20-IK
DKL.262025.DEK-IK	2.0	26	25	L					
DKN.263035.DEK-IK	3.0	26	35	N	S-DK-2-3			DEK.N3 ...	SBD.26.20-IK
DKN.264040.DEK-IK	4.0	26	40	N	S-DK-4-6			DEK.N4 ...	SBD.26.20-IK
↳ ...									

* Montageschlüssel ist nicht im Lieferumfang enthalten und muss separat bestellt werden.

* Montageschlüssel / assembly key

* Assembly key is not included in the scope of delivery and must be ordered separately.



SYSTEM D-GROOVING

Einstecken mit ein- oder zweischneidigen Schneideinsätzen

grooving with one- or two-cutting edges inserts

Typ DKDEK-IK

Klinge, mit Innenkühlung, für Schneideinsatz DEK

blade, with internal cooling, for insert DEK

Stechtiefe t max. 50 mm
Stechbreite b 2.0 - 4.0 mm

depth of groove t max. 50 mm
width of groove b 2.0 - 4.0 mm

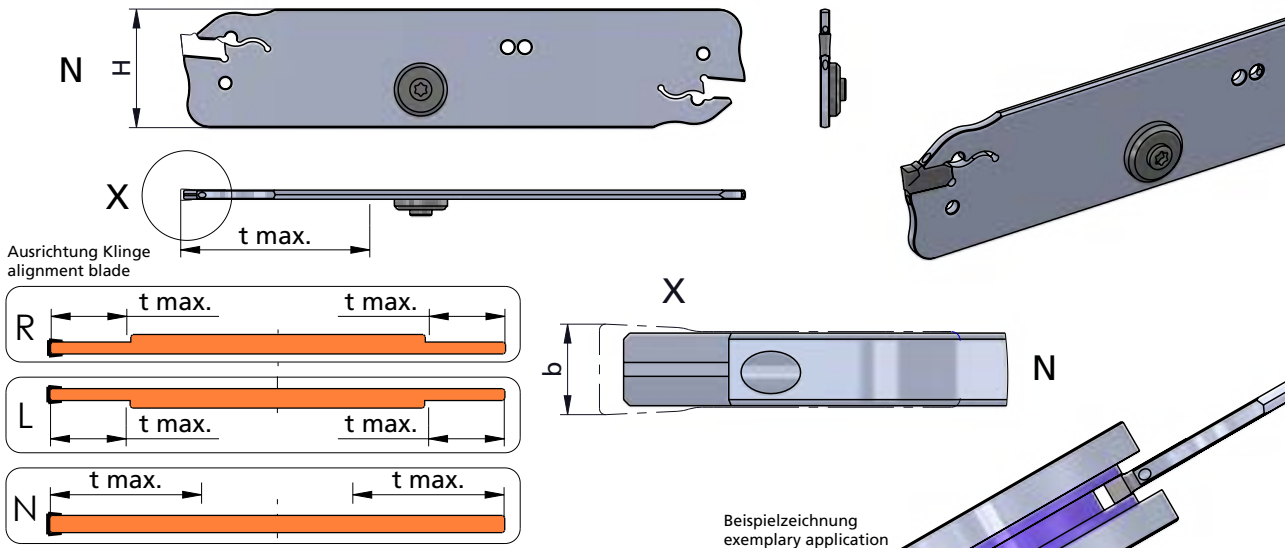

Neutral (N): wie gezeichnet

Neutral (N): as shown

Abmessungen in mm

dimensions in mm

Bestellnummer part number	Stechbreite b width of groove b	H	t max.	Ausrichtung Schneide alignment cutting edge	Montageschlüssel * assembly key *	Verschlusschraube coolant screw	Schrauben- schlüssel wrench	Schneideinsatz Typ insert type	Spannblock Typ clamping block type
DKR.322025.DEK-IK	2.0	32	25	R		DS-M4/3-IK	T15F		
DKL.322025.DEK-IK	2.0	32	25	L	S-DK-2-3			DEK.N2 ...	SBD.32.25-IK
DKN.323050.DEK-IK	3.0	32	50	N	S-DK-2-3			DEK.N3 ...	SBD.32.25-IK
DKN.324050.DEK-IK	4.0	32	50	N	S-DK-4-6			DEK.N4 ...	SBD.32.25-IK

* Montageschlüssel ist nicht im Lieferumfang enthalten und muss separat bestellt werden.

* Montageschlüssel / assembly key

* Assembly key is not included in the scope of delivery and must be ordered separately.

Bestellbeispiel:
für rechte Ausführung
DKR.322025.DEK-IK + S-DK-2-3



order-example:
righthand version
DKR.322025.DEK-IK + S-DK-2-3

SYSTEM D-GROOVING

Einstecken mit ein- oder zweischneidigen Schneideinsätzen

grooving with one- or two-cutting edges inserts

Typ DZ24.M1

Schneideinsatz lang, zweischneidig, Spanformer M1

insert long, two-cutting edges, chipbreaker M1

Stechbreite b
2.0 / 3.0 / 4.0 / 5.0 / 6.0 mm

width of groove b
2.0 / 3.0 / 4.0 / 5.0 / 6.0 mm



Spangeometrie: siehe "Allgemeine Beschreibung"
cutting geometry: look at the "General instruction"

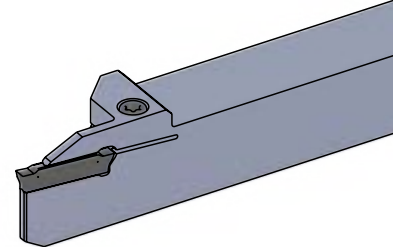
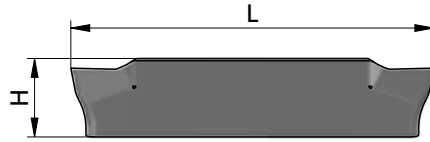

Ausrichtung Schneide
alignment cutting edge

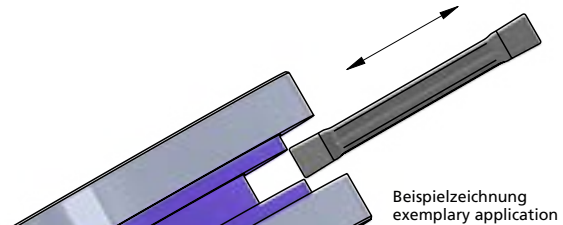
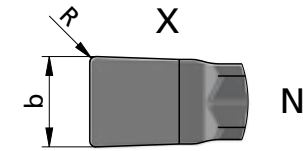
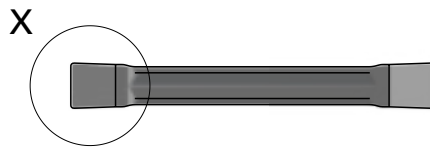
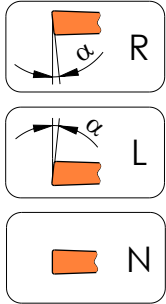

Beispielzeichnung
exemplary application

Neutral (N): wie gezeichnet

Neutral (N): as shown

Abmessungen in mm

dimensions in mm

Bestellnummer part number	b	R	L	H	α	Ausrichtung Schneide alignment cutting edge					Klemhalter Typ toolholder type	Klinge Typ blade type
							P04C	VC10	VP12	K06P		
DZ24.R2015.M1	2.0	0.15	24	5.15	6°	R	●	●	●			
DZ24.L2015.M1	2.0	0.15	24	5.15	6°	L	●	●	●			
DZ24.N2020.M1	2.0	0.20	24	5.15	0°	N	●	●	●			
DZ24.R3020.M1	3.0	0.20	24	5.15	6°	R	●	●	●	DHR. ... DHL. ...		
DZ24.L3020.M1	3.0	0.20	24	5.15	6°	L	●	●	●			
DZ24.N3020.M1	3.0	0.20	24	5.15	0°	N	●	●	●			
DZ24.R4030.M1	4.0	0.30	24	5.15	4°	R	●	●	●	DSR. ... DSL. ...	DKR.D24 DKL.D24 DKN.D24	
DZ24.L4030.M1	4.0	0.30	24	5.15	4°	L	●	●	●			
DZ24.N4030.M1	4.0	0.30	24	5.15	0°	N	●	●	●			
DZ24.N5040.M1	5.0	0.40	24	5.15	0°	N	●	●	●	DIR.D24-IK DIL.D24-IK		
DZ24.N6040.M1	6.0	0.40	24	5.15	0°	N	●	●	●			

SYSTEM D-GROOVING

Einstecken mit ein- oder zweischneidigen Schneideinsätzen

grooving with one- or two-cutting edges inserts

Typ DZ24.F1

Schneideinsatz lang, zweischneidig, Spanformer F1

insert long, two-cutting edges, chipbreaker F1

Stechbreite b
2.0 / 3.0 / 4.0 / 5.0 mm

width of groove b
2.0 / 3.0 / 4.0 / 5.0 mm

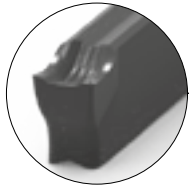

Spangeometrie: siehe "Allgemeine Beschreibung"
cutting geometry: look at the "General instruction"

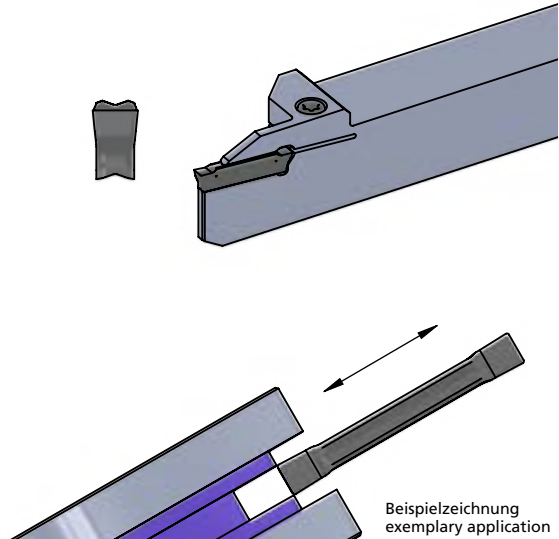
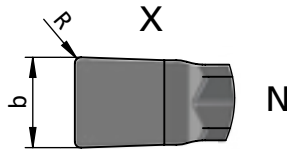
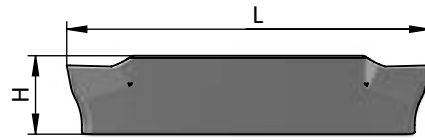

Beispielzeichnung
exemplary application

Ausrichtung Schneide
alignment cutting edge

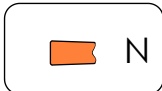
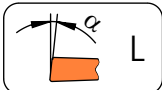
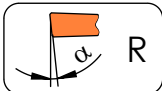

Neutral (N): wie gezeichnet

Neutral (N): as shown

Abmessungen in mm

dimensions in mm

Bestellnummer part number	b	R	L	H	α	Ausrichtung Schneide alignment cutting edge					Klemhalter Typ toolholder type	Klinge Typ blade type
							P04C	VC10	VP12	K06P		
DZ24.R2015.F1	2.0	0.15	24	5.15	6°	R	●	●	●			
DZ24.L2015.F1	2.0	0.15	24	5.15	6°	L	●	●	●			
DZ24.N2020.F1	2.0	0.20	24	5.15	0°	N	●	●	●		DHR. ... DHL. ...	
DZ24.R3020.F1	3.0	0.20	24	5.15	6°	R	●	●	●			
DZ24.L3020.F1	3.0	0.20	24	5.15	6°	L	●	●	●			
DZ24.N3020.F1	3.0	0.20	24	5.15	0°	N	●	●	●		DSR. ... DSL. ...	DKR.D24 DKL.D24 DKN.D24
DZ24.R4030.F1	4.0	0.30	24	5.15	5°	R	●	●	●			
DZ24.L4030.F1	4.0	0.30	24	5.15	5°	L	●	●	●			
DZ24.N4030.F1	4.0	0.30	24	5.15	0°	N	●	●	●		DIR.D24-IK DIL.D24-IK	
DZ24.N5040.F1	5.0	0.40	24	5.15	0°	N	●	●	●			

Bestellbeispiel:
für Sorte P04C:
DZ24.R2015.F1/P04C

order-example:
grade P04C:
DZ24.R2015.F1/P04C

SYSTEM D-GROOVING

Einstecken mit ein- oder zweischneidigen Schneideinsätzen

grooving with one- or two-cutting edges inserts

Typ DZ24.S1

Schneideinsatz lang, zweischneidig, Spanformer S1

insert long, two-cutting edges, chipbreaker S1

Stechbreite b
2.0 / 3.0 / 4.0 / 5.0 / 6.0 mm

width of groove b
2.0 / 3.0 / 4.0 / 5.0 / 6.0 mm



Spangeometrie: siehe "Allgemeine Beschreibung"
cutting geometry: look at the "General instruction"

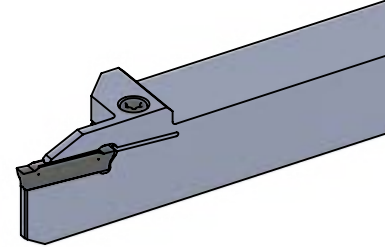
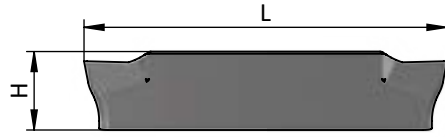

Ausrichtung Schneide
alignment cutting edge

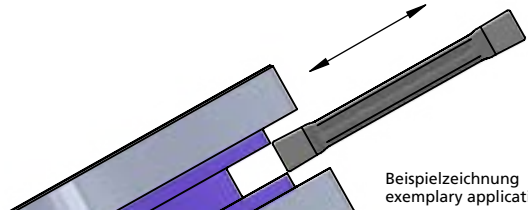
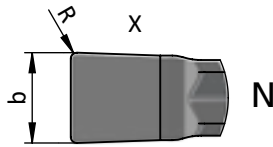
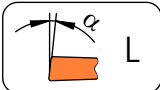

Beispielzeichnung
exemplary application

Neutral (N): wie gezeichnet

Neutral (N): as shown

Abmessungen in mm

dimensions in mm

Bestellnummer part number	b	R	L	H	α	Ausrichtung Schneide alignment cutting edge					Klemmhalter Typ toolholder type	Klinge Typ blade type
							P04C	VC10	VP12	K06P		
DZ24.R2015.S1	2.0	0.15	24	5.15	6°	R	●	●	●			
DZ24.L2015.S1	2.0	0.15	24	5.15	6°	L	●	●	●			
DZ24.N2020.S1	2.0	0.20	24	5.15	0°	N	●	●	●			
DZ24.R3020.S1	3.0	0.20	24	5.15	6°	R	●	●	●	DHR. ... DHL. ...		
DZ24.L3020.S1	3.0	0.20	24	5.15	6°	L	●	●	●			
DZ24.N3020.S1	3.0	0.20	24	5.15	0°	N	●	●	●			
DZ24.R4030.S1	4.0	0.30	24	5.15	6°	R	●	●	●	DSR. ... DSL. ...	DKR.D24 DKL.D24 DKN.D24	
DZ24.L4030.S1	4.0	0.30	24	5.15	6°	L	●	●	●			
DZ24.N4040.S1	4.0	0.40	24	5.15	0°	N	●	●	●			
DZ24.N5040.S1	5.0	0.40	24	5.15	0°	N	●	●	●	DIR.D24-IK DIL.D24-IK		
DZ24.N6040.S1	6.0	0.40	24	5.15	0°	N	●	●	●			

SYSTEM D-GROOVING

Einstecken mit ein- oder zweischneidigen Schneideinsätzen

grooving with one- or two-cutting edges inserts

Typ DZ24.T1

Schneideinsatz lang, zweischneidig, Spanformer T1

insert long, two-cutting edges, chipbreaker T1

Stechbreite b
2.0 / 3.0 / 4.0 / 5.0 / 6.0 mm

width of groove b
2.0 / 3.0 / 4.0 / 5.0 / 6.0 mm

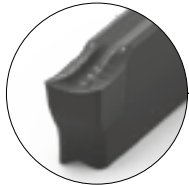

Spangeometrie: siehe "Allgemeine Beschreibung"
cutting geometry: look at the "General instruction"

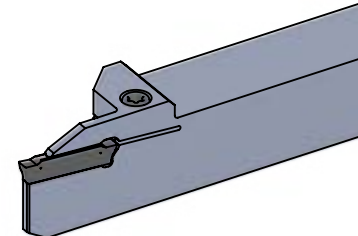

Ausrichtung Schneide
alignment cutting edge

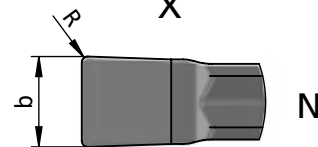
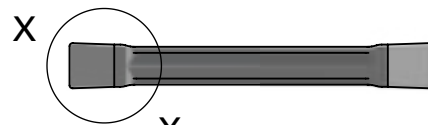
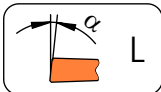
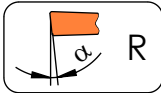

Beispielzeichnung
exemplary application

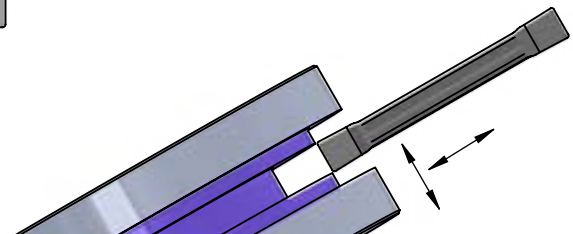

Neutral (N): wie gezeichnet

Neutral (N): as shown

Abmessungen in mm

dimensions in mm

Bestellnummer part number	b	R	L	H	α	Ausrichtung Schneide alignment cutting edge					Klemhalter Typ toolholder type	Klinge Typ blade type
							P04C	VC10	VP12	K06P		
DZ24.R2020.T1	2.0	0.20	24	5.15	6°	R	●	●	●		DHR. ... DHL. ...	
DZ24.L2020.T1	2.0	0.20	24	5.15	6°	L	●	●	●			
DZ24.N2020.T1	2.0	0.20	24	5.15	0°	N	●	●	●			
DZ24.R3020.T1	3.0	0.20	24	5.15	6°	R	●	●	●		DSR. ... DSL. ...	DKR.D24 DKL.D24 DKN.D24
DZ24.L3020.T1	3.0	0.20	24	5.15	6°	L	●	●	●			
DZ24.N3030.T1	3.0	0.30	24	5.15	0°	N	●	●	●			
DZ24.N4040.T1	4.0	0.40	24	5.15	0°	N	●	●	●		DIR.D24-IK DIL.D24-IK	
DZ24.N5040.T1	5.0	0.40	24	5.15	0°	N	●	●	●			
DZ24.N6040.T1	6.0	0.40	24	5.15	0°	N	●	●	●			

Bestellbeispiel:
für Sorte P04C:
DZ24.R2020.T1/P04C

order-example:
grade P04C:
DZ24.R2020.T1/P04C

SYSTEM D-GROOVING

Einstecken mit ein- oder zweischneidigen Schneideinsätzen

grooving with one- or two-cutting edges inserts

Typ DZ24.MV

Schneideinsatz lang, zweischneidig, Spanformer MV (Vollradius)

insert long, two-cutting edges, chipbreaker MV (full radius)

Stechbreite b
2.0 / 3.0 / 4.0 / 5.0 / 6.0 mm

width of groove b
2.0 / 3.0 / 4.0 / 5.0 / 6.0 mm

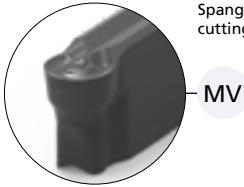

Spangeometrie: siehe "Allgemeine Beschreibung"
cutting geometry: look at the "General instruction"

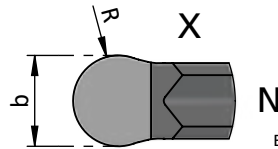
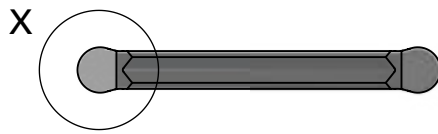
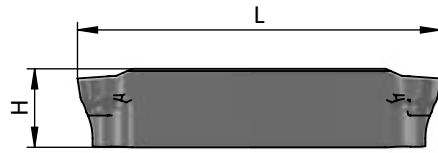

Ausrichtung Schneide
alignment cutting edge



Beispielzeichnung
exemplary application

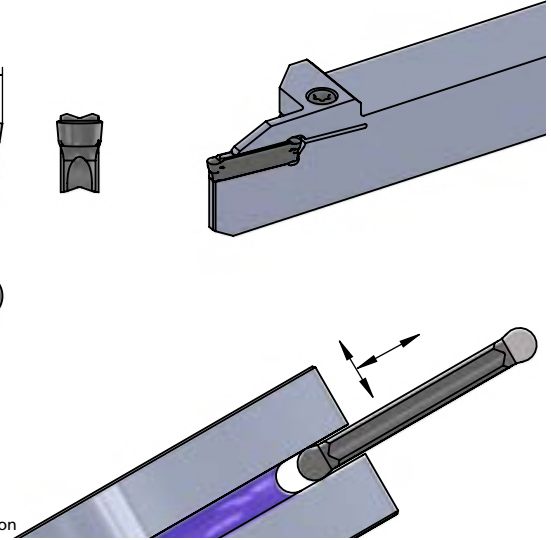

Neutral (N): wie gezeichnet

Neutral (N): as shown

Abmessungen in mm

dimensions in mm

Bestellnummer part number	b	R	L	H	α	Ausrichtung Schneide alignment cutting edge					Klemmhalter Typ toolholder type	Klinge Typ blade type
							P04C	VC10	VP12	K06P		
DZ24.N20VR.MV	2.0	1.0	24	5.15	0°	N	●	●	●		DHR. ... DHL. ...	
DZ24.N30VR.MV	3.0	1.5	24	5.15	0°	N	●	●	●			
DZ24.N40VR.MV	4.0	2.0	24	5.15	0°	N	●	●	●		DSR. ... DSL. ...	DKR.D24 DKL.D24 DKN.D24
DZ24.N50VR.MV	5.0	2.5	24	5.15	0°	N	●	●	●		DIR.D24-IK DIL.D24-IK	
DZ24.N60VR.MV	6.0	3.0	24	5.15	0°	N	●	●	●			

SYSTEM D-GROOVING

Einstecken mit ein- oder zweischneidigen Schneideinsätzen

grooving with one- or two-cutting edges inserts

Typ DZ24.LM

Schneideinsatz lang, zweischneidig, Spanformer LM

insert long, two-cutting edges, chipbreaker LM

Stechbreite b
2.0 / 3.0 / 4.0 / 5.0 / 6.0 mm

width of groove b
2.0 / 3.0 / 4.0 / 5.0 / 6.0 mm



Spangeometrie: siehe "Allgemeine Beschreibung"
cutting geometry: look at the "General instruction"

LM

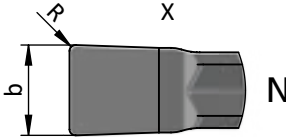
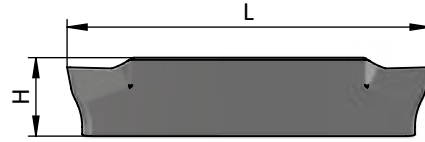

Ausrichtung Schneide
alignment cutting edge

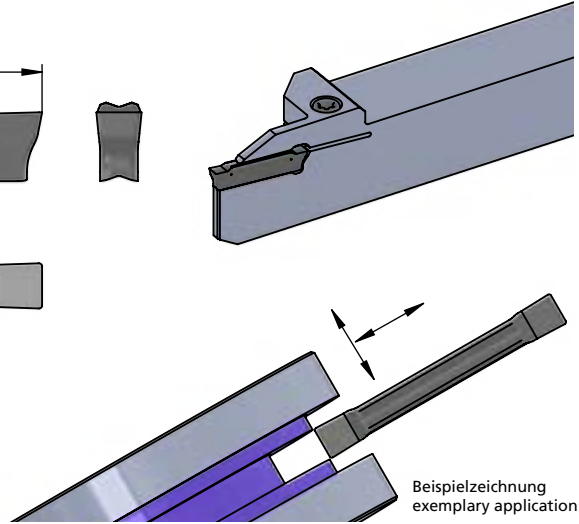

Beispielzeichnung
exemplary application

Neutral (N): wie gezeichnet

Neutral (N): as shown

Abmessungen in mm

dimensions in mm

Bestellnummer part number	b	R	L	H	α	Ausrichtung Schneide alignment cutting edge					Klemmhalter Typ toolholder type	Klinge Typ blade type
							P04C	VC10	VP12	K06P		
DZ24.N2020.LM	2.0	0.2	24	5.15	0°	N				●	DHR. ... DHL. ...	DKR.D24 DKL.D24 DKN.D24
DZ24.N3030.LM	3.0	0.3	24	5.15	0°	N				●		
DZ24.N4040.LM	4.0	0.4	24	5.15	0°	N				●	DIR.D24-IK DIL.D24-IK	
DZ24.N5040.LM	5.0	0.4	24	5.15	0°	N				●		
DZ24.N6050.LM	6.0	0.5	24	5.15	0°	N				●		

Bestellbeispiel:
für Sorte K06P:
DZ24.N2020.LM/K06P

order-example:
grade K06P:
DZ24.N2020.LM/K06P

SYSTEM D-GROOVING

Einstecken mit ein- oder zweischneidigen Schneideinsätzen

grooving with one- or two-cutting edges inserts

Typ DE24.M1

Schneideinsatz lang, einschneidig, Spanformer M1

insert long, single-edge, chipbreaker M1

Stechbreite b
2.0 / 3.0 / 4.0 mm

width of groove b
2.0 / 3.0 / 4.0 mm



Spangeometrie: siehe "Allgemeine Beschreibung"
cutting geometry: look at the "General instruction"

M1

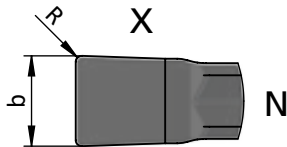
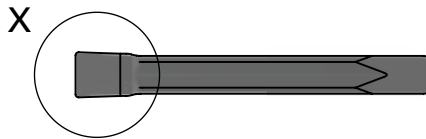
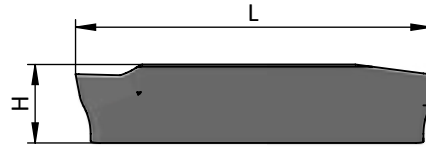

Beispielzeichnung
exemplary application

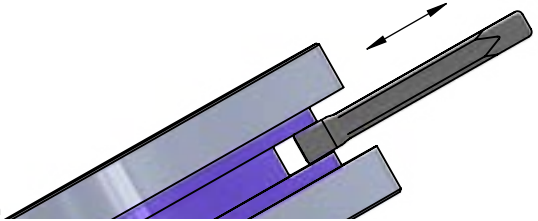
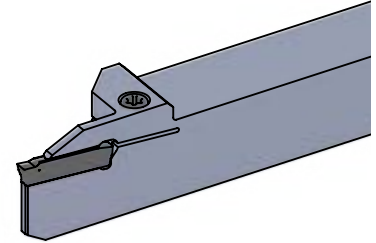

Ausrichtung Schneide
alignment cutting edge

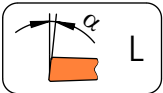
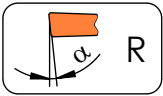

Neutral (N): wie gezeichnet

Neutral (N): as shown

Abmessungen in mm

dimensions in mm

Bestellnummer part number	b	R	L	H	α	Ausrichtung Schneide alignment cutting edge					Klemmhalter Typ toolholder type	Klinge Typ blade type
							P04C	VC10	VP12	K06P		
DE24.R2015.M1	2.0	0.15	23.5	5.15	6°	R	●	●	●			
DE24.L2015.M1	2.0	0.15	23.5	5.15	6°	L	●	●	●			
DE24.N2020.M1	2.0	0.20	23.5	5.15	0°	N	●	●	●	DHR. ... DHL. ...		
DE24.R3020.M1	3.0	0.20	23.5	5.15	6°	R	●	●	●		DKR.D24 DKL.D24	
DE24.L3020.M1	3.0	0.20	23.5	5.15	6°	L	●	●	●			
DE24.N3020.M1	3.0	0.20	23.5	5.15	0°	N	●	●	●		DKN.D24	
										DIR.D24-IK DIL.D24-IK		
DE24.N4030.M1	4.0	0.30	23.5	5.15	0°	N	●	●	●			

SYSTEM D-GROOVING

Einstecken mit ein- oder zweischneidigen Schneideinsätzen

grooving with one- or two-cutting edges inserts

Typ DE24.F1

Schneideinsatz lang, einschneidig, Spanformer F1

insert long, single-edge, chipbreaker F1

Stechbreite b
2.0 / 3.0 / 4.0 mm

width of groove b
2.0 / 3.0 / 4.0 mm

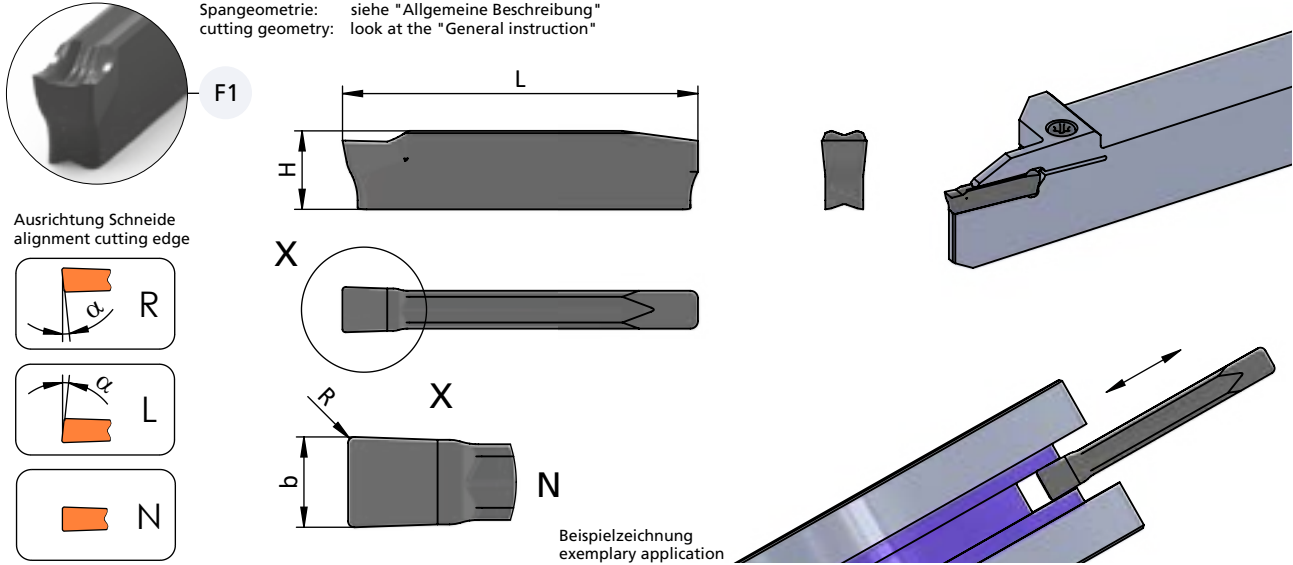

Spangeometrie: siehe "Allgemeine Beschreibung"
cutting geometry: look at the "General instruction"

Ausrichtung Schneide
alignment cutting edge

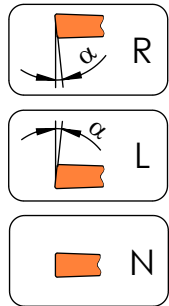

Beispielzeichnung
exemplary application

Neutral (N): wie gezeichnet

Neutral (N): as shown

Abmessungen in mm

dimensions in mm

Bestellnummer part number	b	R	L	H	α	Ausrichtung Schneide alignment cutting edge					Klemmhalter Typ toolholder type	Klinge Typ blade type
							P04C	VC10	VP12	K06P		
DE24.R2015.F1	2.0	0.15	23.5	5.15	6°	R	●	●	●		DHR. ... DHL. ...	
DE24.L2015.F1	2.0	0.15	23.5	5.15	6°	L	●	●	●			
DE24.N2020.F1	2.0	0.20	23.5	5.15	0°	N	●	●	●			
DE24.R3020.F1	3.0	0.20	23.5	5.15	6°	R	●	●	●		DSR. ... DSL. ...	DKR.D24 DKL.D24 DKN.D24
DE24.L3020.F1	3.0	0.20	23.5	5.15	6°	L	●	●	●			
DE24.N3020.F1	3.0	0.20	23.5	5.15	0°	N	●	●	●			
DE24.N4030.F1	4.0	0.30	23.5	5.15	0°	N	●	●	●		DIR.D24-IK DIL.D24-IK	

Bestellbeispiel:
für Sorte P04C:
DE24.R2015.F1/P04C

order-example:
grade P04C:
DE24.R2015.F1/P04C

SYSTEM D-GROOVING

Einstecken mit
ein- oder zweischneidigen
Schneideinsätzen

grooving with
one- or two-cutting edges
inserts

Typ DE24.S1

Schneideinsatz lang,
einschneidig,
Spanformer S1

insert long,
single-edge,
chipbreaker S1

Stechbreite b
2.0 / 3.0 / 4.0 mm

width of groove b
2.0 / 3.0 / 4.0 mm

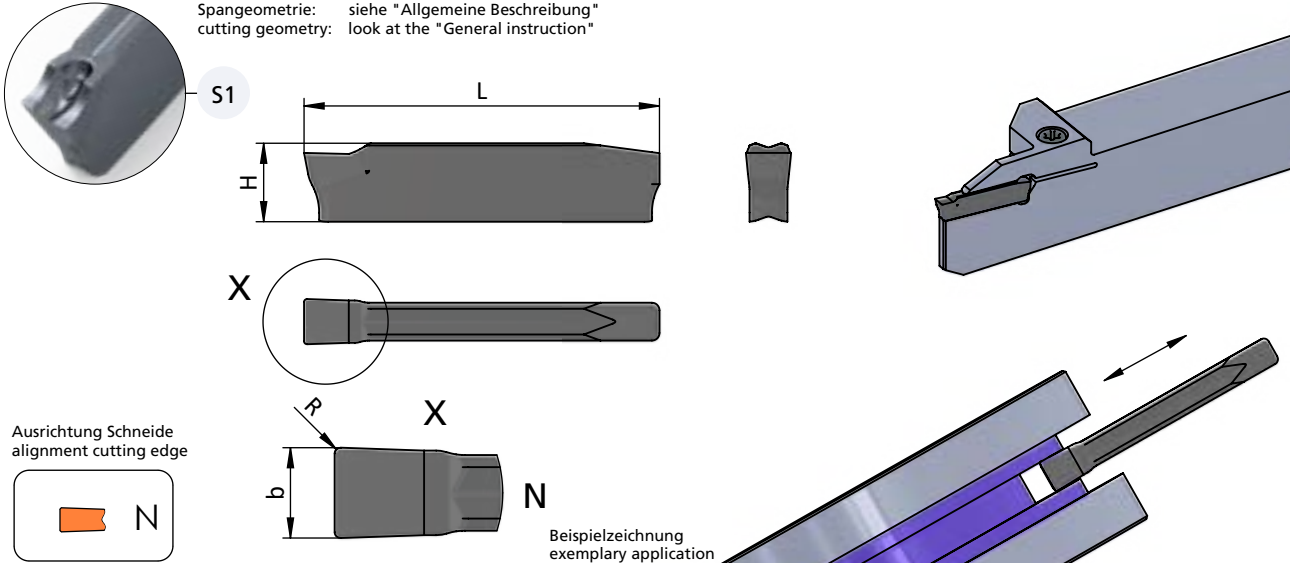

Spangeometrie: siehe "Allgemeine Beschreibung"
cutting geometry: look at the "General instruction"

Ausrichtung Schneide
alignment cutting edge



Beispielzeichnung
exemplary application

Neutral (N): wie gezeichnet

Neutral (N): as shown

Abmessungen in mm

dimensions in mm

Bestellnummer part number	b	R	L	H	α	Ausrichtung Schneide alignment cutting edge					Klemmhalter Typ toolholder type	Klinge Typ blade type
							P04C	VC10	VP12	K06P		
DE24.N2020.S1	2.0	0.20	23.5	5.15	0°	N	●	●	●		DHR. ... DHL. ...	
DE24.N3030.S1	3.0	0.30	23.5	5.15	0°	N	●	●	●		DSR. ... DSL. ...	DKR.D24 DKL.D24 DKN.D24
DE24.N4040.S1	4.0	0.40	23.5	5.15	0°	N	●	●	●		DIR.D24-IK DIL.D24-IK	

SYSTEM D-GROOVING

Einstecken mit ein- oder zweischneidigen Schneideinsätzen

grooving with one- or two-cutting edges inserts

Typ DE24.T1

Schneideinsatz lang, einschneidig, Spanformer T1

insert long, single-edge, chipbreaker T1

Stechbreite b
2.0 / 3.0 / 4.0 mm

width of groove b
2.0 / 3.0 / 4.0 mm

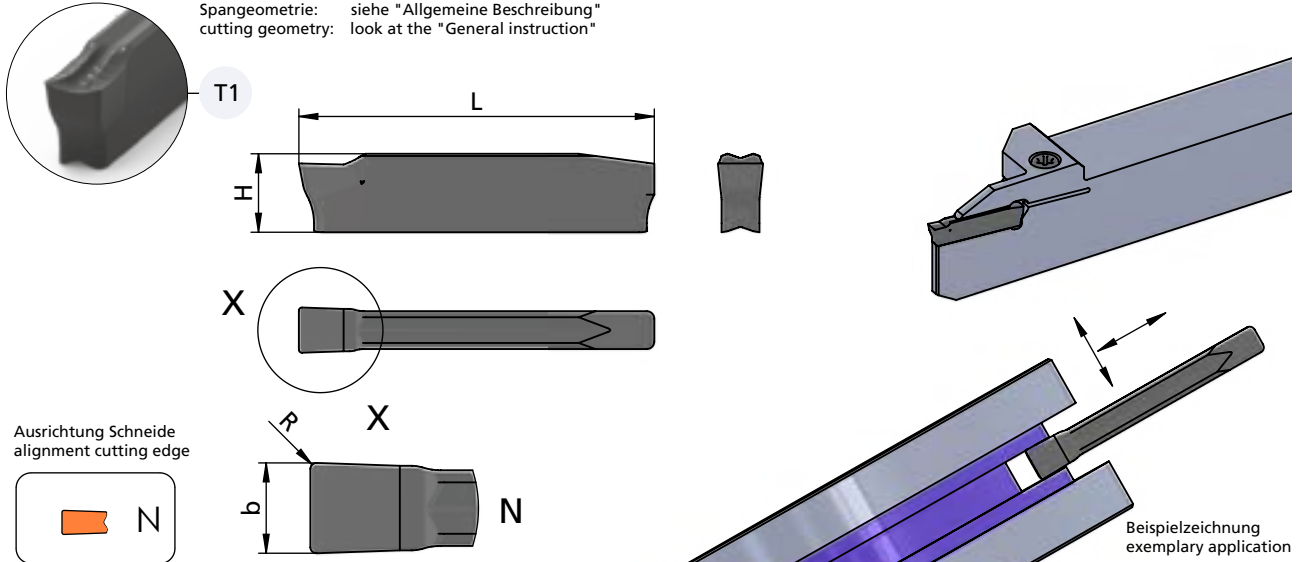

Neutral (N): wie gezeichnet
Abmessungen in mm

Neutral (N): as shown
dimensions in mm

Beispielzeichnung
exemplary application

Bestellnummer part number	b	R	L	H	α	Ausrichtung Schneide alignment cutting edge					Klemmhalter Typ toolholder type	Klinge Typ blade type
							P04C	VC10	VP12	K06P		
DE24.N2020.T1	2.0	0.20	23.5	5.15	0°	N	●	●	●		DHR. ... DHL. ...	
DE24.N3030.T1	3.0	0.30	23.5	5.15	0°	N	●	●	●		DSR. ... DSL. ...	DKR.D24 DKL.D24 DKN.D24
DE24.N4040.T1	4.0	0.40	23.5	5.15	0°	N	●	●	●		DIR.D24-IK DIL.D24-IK	

Bestellbeispiel:
für Sorte P04C:
DE24.N2020.T1/P04C

order-example:
grade P04C:
DE24.N2020.T1/P04C

05-
67

SYSTEM D-GROOVING

Einstecken mit
ein- oder zweischneidigen
Schneideinsätzen

grooving with
one- or two-cutting edges
inserts

Typ DE24.LM

Schneideinsatz lang,
einschneidig,
Spanformer LM

insert long,
single-edge,
chipbreaker LM

Stechbreite b
2.0 / 3.0 / 4.0 mm

width of groove b
2.0 / 3.0 / 4.0 mm



Spangeometrie: siehe "Allgemeine Beschreibung"
cutting geometry: look at the "General instruction"

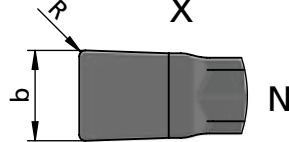
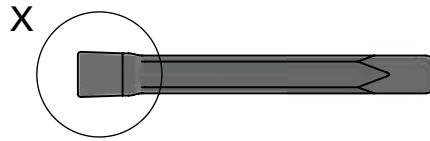
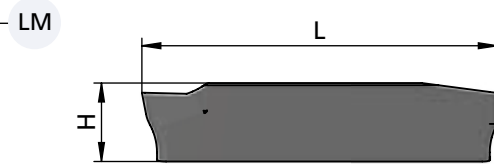

Ausrichtung Schneide
alignment cutting edge



Beispielzeichnung
exemplary application

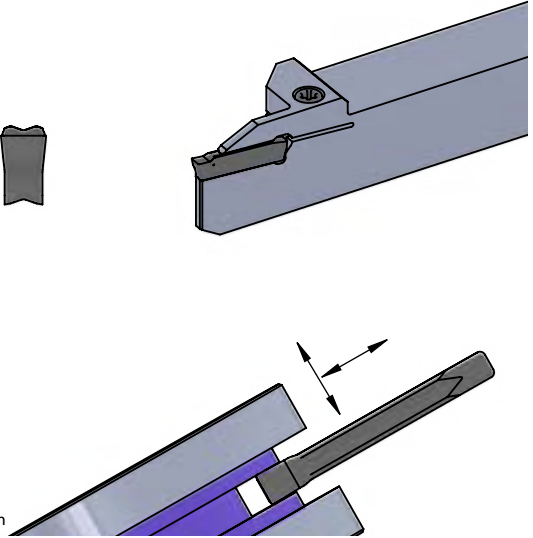

Neutral (N): wie gezeichnet

Neutral (N): as shown

Abmessungen in mm

dimensions in mm

Bestellnummer part number	b	R	L	H	α	Ausrichtung Schneide alignment cutting edge					Klemmhalter Typ toolholder type	Klinge Typ blade type
							P04C	VC10	VP12	K06P		
DE24.N2020.LM	2.0	0.20	23.5	5.15	0°	N				●	DHR. ... DHL. ...	
DE24.N3030.LM	3.0	0.30	23.5	5.15	0°	N				●	DSR. ... DSL. ...	DKR.D24 DKL.D24 DKN.D24
DE24.N4040.LM	4.0	0.40	23.5	5.15	0°	N				●	DIR.D24-IK DIL.D24-IK	

SYSTEM D-GROOVING

Einstecken mit ein- oder zweischneidigen Schneideinsätzen

grooving with one- or two-cutting edges inserts

Typ DEK.M1

Schneideinsatz kurz, einschneidig, Spanformer M1

insert short, single-edge, chipbreaker M1

Stechbreite b
2.0 / 3.0 / 4.0 mm

width of groove b
2.0 / 3.0 / 4.0 mm



Spangeometrie: siehe "Allgemeine Beschreibung"
cutting geometry: look at the "General instruction"

M1

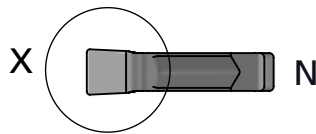
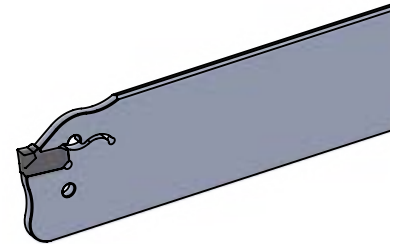
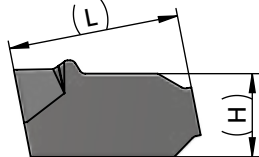

Ausrichtung Schneide
alignment cutting edge

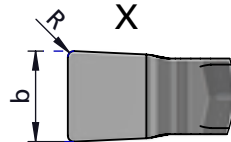

Beispielzeichnung
exemplary application

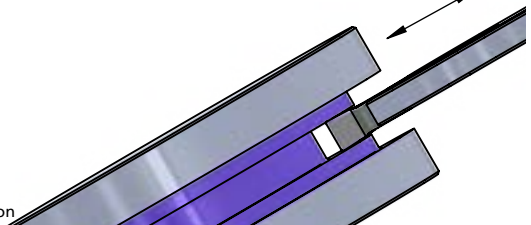

Neutral (N): wie gezeichnet

Neutral (N): as shown

Abmessungen in mm

dimensions in mm

Bestellnummer part number	b	R	(L)	(H)	α	Ausrichtung Schneide alignment cutting edge					Klinge Typ blade type
							P04C	VC10	VP12	K06P	
DEK.N2020.M1	2.0	0.2	11.5	5.5	0°	N	●	●	●		DKR.DEK DKL.DEK DKN.DEK
DEK.N3020.M1	3.0	0.2	11.5	5.5	0°	N	●	●	●		
DEK.N4030.M1	4.0	0.3	13.5	5.5	0°	N	●	●	●		

Bestellbeispiel:
für Sorte P04C:
DEK.N2020.M1/P04C

order-example:
grade P04C:
DEK.N2020.M1/P04C

SYSTEM D-GROOVING

Einstecken mit ein- oder zweischneidigen Schneideinsätzen

grooving with one- or two-cutting edges inserts

Typ DEK.M2

Schneideinsatz kurz, einschneidig, Spanformer M2

insert short, single-edge, chipbreaker M2

Stechbreite b
2.0 / 3.0 / 4.0 mm

width of groove b
2.0 / 3.0 / 4.0 mm



Spangeometrie: siehe "Allgemeine Beschreibung"
cutting geometry: look at the "General instruction"

M2

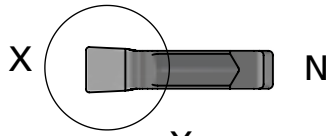
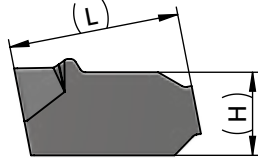

Ausrichtung Schneide
alignment cutting edge

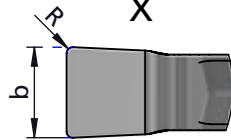

Beispielzeichnung
exemplary application

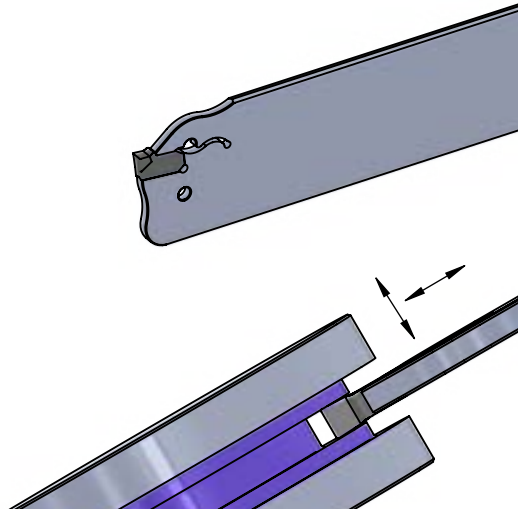

Neutral (N): wie gezeichnet

Neutral (N): as shown

Abmessungen in mm

dimensions in mm



Bestellnummer part number	b	R	(L)	(H)	α	Ausrichtung Schneide alignment cutting edge					Klinge Typ blade type
							P04C	VC10	VP12	K06P	
DEK.N2020.M2	2.0	0.2	11.5	5.5	0°	N	●	●	●		DKR.DEK DKL.DEK DKN.DEK
DEK.N3030.M2	3.0	0.3	11.5	5.5	0°	N	●	●	●		
DEK.N4040.M2	4.0	0.4	13.5	5.5	0°	N	●	●	●		

SYSTEM D-GROOVING

Einstecken mit ein- oder zweischneidigen Schneideinsätzen

grooving with one- or two-cutting edges inserts

Typ DEK.S1

Schneideinsatz kurz, einschneidig, Spanformer S1

insert short, single-edge, chipbreaker S1

Stechbreite b
2.0 / 3.0 / 4.0 mm

width of groove b
2.0 / 3.0 / 4.0 mm



Spangeometrie: siehe "Allgemeine Beschreibung"
cutting geometry: look at the "General instruction"

S1

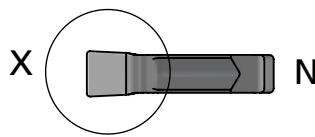
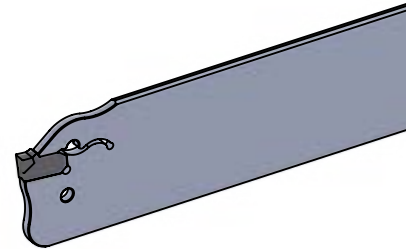
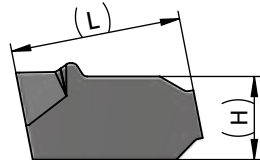

Ausrichtung Schneide
alignment cutting edge

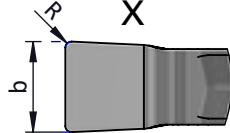

Beispielzeichnung
exemplary application

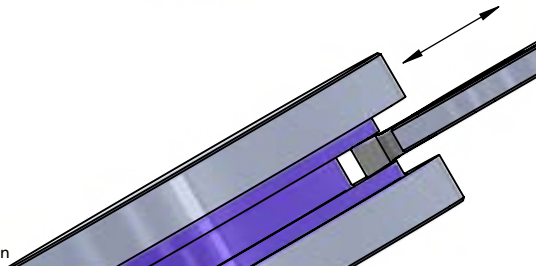

Neutral (N): wie gezeichnet

Neutral (N): as shown

Abmessungen in mm

dimensions in mm



Bestellnummer part number	b	R	(L)	(H)	α	Ausrichtung Schneide alignment cutting edge					Klinge Typ blade type
							P04C	VC10	VP12	K06P	
DEK.N2020.S1	2.0	0.2	11.5	5.5	0°	N	●	●	●		DKR.DEK DKL.DEK DKN.DEK
DEK.N3020.S1	3.0	0.2	11.5	5.5	0°	N	●	●	●		
DEK.N4040.S1	4.0	0.4	13.5	5.5	0°	N	●	●	●		

Bestellbeispiel:
für Sorte P04C:
DEK.N2020.S1/P04C

order-example:
grade P04C:
DEK.N2020.S1/P04C

SYSTEM D-GROOVING

Einstecken mit
ein- oder zweischneidigen
Schneideinsätzen

grooving with
one- or two-cutting edges
inserts

Typ DEK.LM

Schneideinsatz kurz,
einschneidig,
Spanformer LM

insert short,
single-edge,
chipbreaker LM

Stechbreite b
2.0 / 3.0 / 4.0 mm

width of groove b
2.0 / 3.0 / 4.0 mm



Spangeometrie: siehe "Allgemeine Beschreibung"
cutting geometry: look at the "General instruction"

LM

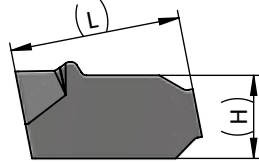

X

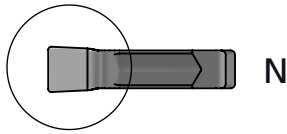

X

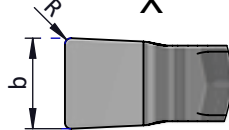

Ausrichtung Schneide
alignment cutting edge



Beispielzeichnung
exemplary application

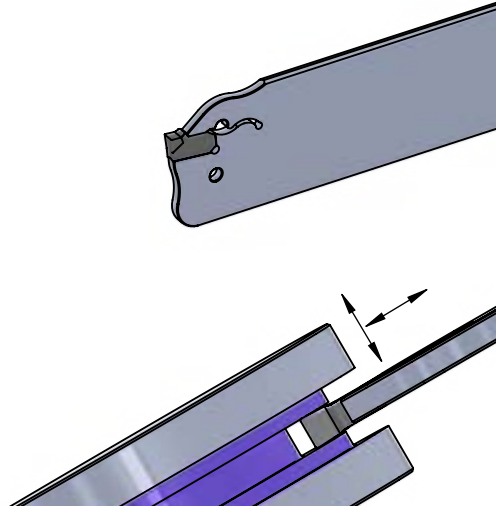

Neutral (N): wie gezeichnet

Neutral (N): as shown

Abmessungen in mm

dimensions in mm



Bestellnummer part number	b	R	(L)	(H)	α	Ausrichtung Schneide alignment cutting edge					Klinge Typ blade type
							P04C	VC10	VP12	K06P	
DEK.N2020.LM	2.0	0.20	11.5	5.5	0°	N				●	DKR.DEK DKL.DEK DKN.DEK
DEK.N3030.LM	3.0	0.30	11.5	5.5	0°	N				●	
DEK.N4040.LM	4.0	0.40	13.5	5.5	0°	N				●	

SYSTEM D-GROOVING

Einstecken mit ein- oder zweischneidigen Schneideinsätzen

grooving with one- or two-cutting edges inserts

Technische Hinweise

Allgemeine Informationen
Hinweise zur Klemmung und zum Wechseln der Schneideinsätze

Technical instructions
General informations
Hints how to insert and remove the inserts

Hinweise zur Klemmung und zum Wechseln der Schneideinsätze

Der Schlüssel wurde so konzipiert, dass er das Material nicht über den sogenannten "Totpunkt" hinweg belastet. Durch dieses Wechselsystem bleibt das Material immer im elastischen Bereich und sorgt so für eine wesentliche Erhöhung des Lebenszyklus.

Hints how to insert and remove the inserts

The assembly key has been designed in such a way that it will not stress the material beyond its "elastic limit". With this alternate system the material always remains in its flexible range and provides a substantial increase in tool life.



- den Montageschlüssel mit Griff nach vorne in die 2 Bohrungen der Klinge einsetzen

- insert assembly key with handle towards the front into the 2 tool location points



- zum Öffnen der Klemmung den Montageschlüssel in Pfeilrichtung schwenken

- when moving the assembly key in the direction of the arrows the insert seat is opened



- die Schneide bis zum Anschlag in den Plattensitz drücken

- load the grooving insert into position and press against the seat



- die Schneide wird sicher geklemmt, wenn der Montageschlüssel in Pfeilrichtung zurück geschwenkt wird

- moving the assembly key forward the insert seat locks and the insert is clamped securely



Beim Wechseln der Schneiden darauf achten, dass der Schlüssel einrastet!

When changing the inserts, make sure that the assembly key engages!



SYSTEM DED

Einstecken mit dreischneidigen Wendeplatten

grooving with three-cutting edges indexable inserts

Technische Hinweise

Hartmetallsorten und Beschichtungen

Technical instructions, carbide grades and coatings

SYSTEM DED

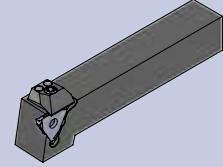

K10F

Universell einsetzbares Feinkornhartmetall mit guter Verschleißfestigkeit. Unbeschichtet geeignet für Anwendungen mit niedrigen und mittleren Schnittgeschwindigkeiten, sowie die Bearbeitung von NE-Metallen.

All purpose micrograin carbide with good abrasion resistance. Uncoated for applications with low or medium cutting speeds and machining of non-ferrous materials.

P04C

Optimierte, sehr universell einsetzbare TIALN-Beschichtung mit hoher Temperaturbeständigkeit bei hoher Härte. Sehr gut geeignet auch für NE-Metalle.

Optimized TIALN coating - very universal with a high resistance to high temperature and hardness. Very suitable also for non-ferrous metals.

AL41F

Sehr universell einsetzbare TIALN-Beschichtung mit hoher Temperaturbeständigkeit bei hoher Härte. Sehr gut geeignet auch für NE-Metalle.

TIALN coating - very universal with a high resistance to high temperature and hardness. Very suitable also for non-ferrous metals.

CN45F

Universell einsetzbare PVD-TIN-Beschichtung. Diese Allround-Sorte ist für niedrige und mittlere Schnittgeschwindigkeiten mit Einschränkung bei NE-Metallen.

PVD-TIN coating - all purpose, all around grade is suitable for low and medium cutting speed with restrictions on non-ferrous materials.

P18C

Universell einsetzbare Hochleistungsschicht mit hoher Oxidationsbeständigkeit, Verschleißfestigkeit und Warmhärte.

Very universal high performance coating with high oxidation resistance, wear resistance and hot hardness resistance.

P07C

Beschichtung für die Bearbeitung von Titan, Edelstahl und Molybdän.

Coating to machine titanium, stainless steel and molybdenum.



SYSTEM DED

Einstecken mit dreischneidigen Wendeplatten

grooving with three-cutting edges indexable inserts

Technische Hinweise

Hartmetallsorten und Beschichtungen

Technical instructions, carbide grades and coatings

SYSTEM DED

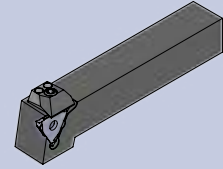

XC2A

Beschichtung mit einer exzellenten Warmhärte, Oxidationsbeständigkeit und thermischen Isolationsfähigkeit. Ideal für Hartzerspanung >60HRC

Coating with excellent hot hardness, high oxidation resistance and thermal insulation capacity. Ideal for hard machining >60 HRC.

P03C

Beschichtung für die Bearbeitung von schwer zerspanbaren Materialien. Sehr gut auch für die Trockenbearbeitung geeignet.

Coating for materials which are difficult to machine. Perfect to use for dry machining.

PD2F

Beschichtung für den universellen Einsatz bei niedrigen und mittleren Schnittgeschwindigkeiten.

Coating for universal use with medium and low speed.

NEME

Beschichtung für die Bearbeitung von Aluminium, Al-Legierungen, NE-Metallen und Kompositwerkstoffen.

Coating for machining aluminium, Al alloys, non-ferrous metals and composite materials.



SYSTEM D-GROOVING

Einstecken mit ein- oder zweischneidigen Schneideinsätzen

grooving with one- or two-cutting edges inserts

Technische Hinweise

Hartmetallsorten und Beschichtungen

Technical instructions, carbide grades and coatings

SYSTEM D-GROOVING

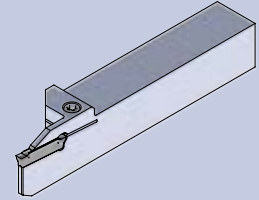

K06P

Unbeschichtete Hartmetallsorte mit 6% Kobalt. Geeignet für Aluminium und NE-Metallbearbeitung, mit polierter Spanfläche. (Aktuell nur für System D-Grooving erhältlich.)

Uncoated carbide grade with 6% cobalt. For machining aluminium and non-ferrous materials, with polished cutting surface. (Only for the system DT-Grooving available.)

P04C

Optimierte, sehr universell einsetzbare TIALN-Beschichtung mit hoher Temperaturbeständigkeit bei hoher Härte. Sehr gut geeignet auch für NE-Metalle.

Optimized TIALN coating - very universal with a high resistance to high temperature and hardness. Very suitable also for non-ferrous metals.

VC10

Verschleißfeste CVD-Beschichtung für die Guss- und Stahlbearbeitung. Feinkornsorte mit 10.5% Kobalt.

Wear-resistant CVD-coating for machining steel and cast iron. Fine grain carbide with 10.5% cobalt.

VP12

Zähe PVD-Beschichtung für die Bearbeitung von Stahl und Rostfrei bei instabilen Bedingungen. Feinkornsorte mit 12.5% Kobalt.

Reliable PVD-coating for machining steel and stainless steels under unstable conditions. Fine grain carbide with 12.5% cobalt.



SYSTEM D-GROOVING

Einstecken mit
ein- oder zweischneidigen
Schneideinsätzen

grooving with
one- or two-cutting edges
inserts

Impressionen

impressions

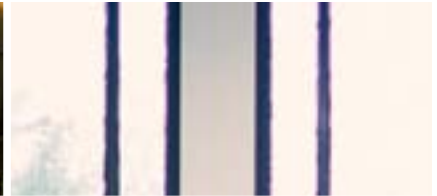

SYSTEM DED

Einstecken mit dreischneidigen Wendeplatten

grooving with three-cutting edges indexable inserts

Technische Hinweise

Schnittdatenempfehlung: metrisch

Schnittgeschwindigkeit: V_c (m/min)
Vorschub: f (mm/U)

Technical instructions, speed and feed recommendation: metric

cutting speed: V_c (m/min)
feed: f (mm/rev)

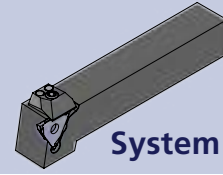

System DED

Werkstoffgruppe material group		Zusammensetzung composition		(Zug-)Festigkeit tensile strength
ISO	Beschreibung / description	Gefüge / structure	Wärmebehandlung / heat treatment	Psi / N/mm ² (Rm) / HB / HRC
P	Unlegierter Stahl unalloyed steel	ca.lapp. 0,15 % C	geglüht / annealed	61000 Psi / 420 N/mm ² / 125 HB
		ca.lapp. 0,45 % C	geglüht / annealed	93000 Psi / 640 N/mm ² / 190 HB
			vergütet / tempered	122000 Psi / 840 N/mm ² / 250 HB
		ca.lapp. 0,75 % C	geglüht / annealed	132000 Psi / 910 N/mm ² / 270 HB
			vergütet / tempered	146500 Psi / 1010 N/mm ² / 300 HB
	Niedriglegierter Stahl low alloyed steel		geglüht / annealed	88500 Psi / 610 N/mm ² / 180 HB
			vergütet / tempered	135000 Psi / 930 N/mm ² / 275 HB
			vergütet / tempered	146500 Psi / 1010 N/mm ² / 300 HB
			vergütet / tempered	174000 Psi / 1200 N/mm ² / 375 HB
	Hochlegierter (Werkzeug)-Stahl highly alloyed steel		geglüht / annealed	99000 Psi / 680 N/mm ² / 200 HB
		gehärtet & angelassen / hardened & tempered	160000 Psi / 1100 N/mm ² / 300 HB	
Nichtrostender Stahl stainless steel		gehärtet & angelassen / hardened & tempered	189000 Psi / 1300 N/mm ² / 400 HB	
		geglüht / annealed	99000 Psi / 680 N/mm ² / 200 HB	
M	Nichtrostender Stahl stainless steel	ferritisch, martensitisch / ferritic, martensitic	geglüht / annealed	99000 Psi / 680 N/mm ² / 200 HB
		martensitisch / martensitic	vergütet / tempered	117500 Psi / 810 N/mm ² / 250 HB
		austenitisch / austenitic	abgeschreckt / quenched	88500 Psi / 610 N/mm ² / 200 HB
K	Grauguss cast iron	austenitisch / austenitic	vergütet / tempered	300 HB
		austenitisch, ferritisch / ferritic, martensitic (Duplex)		113000 Psi / 780 N/mm ² / 230 HB
		perlitisch, ferritisch / pearlitic, ferritic		51000 Psi / 350 N/mm ² / 180 HB
K	Gusseisen mit Kugelgraphit cast iron with nodular graphite	perlitisch (martensitisch) / pearlitic (martensitic)		72500 Psi / 500 N/mm ² / 260 HB
		ferritisch / ferritic		72500 Psi / 500 N/mm ² / 160 HB
	Temperguss malleable iron	perlitisch / pearlitic		122500 Psi / 845 N/mm ² / 250 HB
		ferritisch / ferritic		63800 Psi / 440 N/mm ² / 130 HB
N	Aluminium - Knetlegierungen wrought aluminum alloys	nicht aushärtbar / uncurable		60 HB
		aushärtbar / curable	ausgehärtet / cured	49000 Psi / 340 N/mm ² / 100 HB
	Aluminium - Gusslegierungen cast aluminum alloys	≤ 12% Si, nicht aushärtbar / uncurable		36250 Psi / 250 N/mm ² / 75 HB
		≤ 12% Si, aushärtbar / curable	ausgehärtet / cured	43500 Psi / 300 N/mm ² / 90 HB
		> 12% Si, nicht aushärtbar / uncurable		63800 Psi / 440 N/mm ² / 130 HB
	Kupfer und Kupferlegierungen (Bronze / Messing) copper and copper alloys (bronze / brass)	PB > 1 %, Automatenlegierungen / free cutting alloys		54500 Psi / 375 N/mm ² / 110 HB
		CuZn, CuSnZn		43500 Psi / 300 N/mm ² / 90 HB
CuSn, bleifrei & Elektrolytisch / lead free & electrolytic			49000 Psi / 340 N/mm ² / 100 HB	
Magnesium &-Legierungen / Mg-alloys	Magnesium und -Legierungen / and -alloys		70 HB	
S	Warmfeste Legierungen heat-resistant alloys	Fe-Basis / Fe base	geglüht / annealed	99000 Psi / 680 N/mm ² / 200 HB
			ausgehärtet / cured	137750 Psi / 950 N/mm ² / 280 HB
		Ni- oder Co-Basis / Ni- or Co-Base	geglüht / annealed	122000 Psi / 840 N/mm ² / 250 HB
			ausgehärtet / cured	171000 Psi / 1180 N/mm ² / 350 HB
			gegossen / cast	156600 Psi / 1080 N/mm ² / 320 HB
	Titanlegierungen titanium alloys	Reintitan / pure titanium		58000 Psi / 400 N/mm ²
	Alpha- + Beta-Legierungen / -alloys	ausgehärtet / cured	152250 Psi / 1050 N/mm ²	
	Beta-Legierungen / -alloys		203000 Psi / 1400 N/mm ² / 410 HB	
H	Gehärteter Stahl hardened steel		gehärtet & angelassen / hardened & tempered	46-55 HRC
			gehärtet & angelassen / hardened & tempered	56-60 HRC
			gehärtet & angelassen / hardened & tempered	61-65 HRC
			gehärtet & angelassen / hardened & tempered	66-70 HRC
	Hartguss / chilled cast iron		gegossen / cast	400 HB
Gehärtetes Guss / hardened cast iron		gehärtet & angelassen / hardened & tempered	55 HRC	
O	Nichtmetallische Werkstoffe non-metallic materials	Kunststoffe, duroplastisch / plastics, duroplastic		≤ 21750 Psi / ≤ 150 N/mm ²
		Kunststoffe, thermoplastisch / plastics, thermoplastic		≤ 14500 Psi / ≤ 100 N/mm ²
		aramidfaserverstärkt / aramid fiber reinforced		≤ 145000 Psi / ≤ 1000 N/mm ²
		glas/kohlefaserverstärkt / glas/carbon fiber reinforced		≤ 145000 Psi / ≤ 1000 N/mm ²
		Graphit / graphite		

Richtige Schnittgeschwindigkeit ist in Abhängigkeit von Dimension und Anwendungssituation zu wählen.

The correct cutting speed must be selected depending on the dimension and application situation.

20 (10 - 50) bevorzugte Wahl / best choice
20 (10 - 50) bedingt möglich / conditionally possible

20 (10 - 50)
empfohlener Startwert (bevorzugter Einsatzbereich)
recommended starting value (preferred application area)
value

SYSTEM DED

Einstechen mit dreischneidigen Wendeplatten

grooving with three-cutting edges indexable inserts

Technische Hinweise

Schnittdatenempfehlung:

Technical instructions, speed and feed recommendation: imperial

cutting speed (SFM): V_c (feet/min)
feed: f (inch/rev)

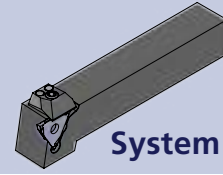

System DED

Werkstoffgruppe material group		Zusammensetzung composition		(Zug-)Festigkeit tensile strength
ISO	Beschreibung / description	Gefüge / structure	Wärmebehandlung / heat treatment	Psi / N/mm ² (Rm) / HB / HRC
P	Unlegierter Stahl unalloyed steel	ca.lapp. 0,15 % C	geglüht / annealed	61000 Psi / 420 N/mm ² / 125 HB
		ca.lapp. 0,45 % C	geglüht / annealed	93000 Psi / 640 N/mm ² / 190 HB
		ca.lapp. 0,75 % C	vergütet / tempered	122000 Psi / 840 N/mm ² / 250 HB
			geglüht / annealed	132000 Psi / 910 N/mm ² / 270 HB
			vergütet / tempered	146500 Psi / 1010 N/mm ² / 300 HB
	Niedriglegierter Stahl low alloyed steel	geglüht / annealed	88500 Psi / 610 N/mm ² / 180 HB	
		vergütet / tempered	135000 Psi / 930 N/mm ² / 275 HB	
		vergütet / tempered	146500 Psi / 1010 N/mm ² / 300 HB	
		vergütet / tempered	174000 Psi / 1200 N/mm ² / 375 HB	
	Hochlegierter (Werkzeug-)Stahl highly alloyed steel	geglüht / annealed	99000 Psi / 680 N/mm ² / 200 HB	
gehärtet & angelassen / hardened & tempered		160000 Psi / 1100 N/mm ² / 300 HB		
Nichtrostender Stahl stainless steel	gehärtet & angelassen / hardened & tempered	189000 Psi / 1300 N/mm ² / 400 HB		
	geglüht / annealed	99000 Psi / 680 N/mm ² / 200 HB		
M	Nichtrostender Stahl stainless steel	ferritisch, martensitisch / ferritic, martensitic	geglüht / annealed	99000 Psi / 680 N/mm ² / 200 HB
		martensitisch / martensitic	vergütet / tempered	117500 Psi / 810 N/mm ² / 250 HB
		austenitisch / austenitic	abgeschreckt / quenched	88500 Psi / 610 N/mm ² / 200 HB
K	Grauguss cast iron	austenitisch / austenitic	vergütet / tempered	300 HB
		austenitisch, ferritisch / ferritic, martensitic (Duplex)		113000 Psi / 780 N/mm ² / 230 HB
		perlitisch, ferritisch / pearlitic, ferritic		51000 Psi / 350 N/mm ² / 180 HB
K	Gusseisen mit Kugelgraphit cast iron with nodular graphite	perlitisch (martensitisch) / pearlitic (martensitic)		72500 Psi / 500 N/mm ² / 260 HB
		ferritisch / ferritic		72500 Psi / 500 N/mm ² / 160 HB
	Temperguss malleable iron	perlitisch / pearlitic		122500 Psi / 845 N/mm ² / 250 HB
		ferritisch / ferritic		63800 Psi / 440 N/mm ² / 130 HB
N	Aluminium - Knetlegierungen wrought aluminum alloys	nicht aushärtbar / uncurable		60 HB
		aushärtbar / curable	ausgehärtet / cured	49000 Psi / 340 N/mm ² / 100 HB
	Aluminium - Gusslegierungen cast aluminum alloys	≤ 12% Si, nicht aushärtbar / uncurable		36250 Psi / 250 N/mm ² / 75 HB
		≤ 12% Si, aushärtbar / curable	ausgehärtet / cured	43500 Psi / 300 N/mm ² / 90 HB
		> 12% Si, nicht aushärtbar / uncurable		63800 Psi / 440 N/mm ² / 130 HB
	Kupfer und Kupferlegierungen (Bronze / Messing) copper and copper alloys (bronze / brass)	PB > 1 %, Automatenlegierungen / free cutting alloys		54500 Psi / 375 N/mm ² / 110 HB
CuZn, CuSnZn			43500 Psi / 300 N/mm ² / 90 HB	
CuSn, bleifrei & Elektrolytisch / lead free & electrolytic			49000 Psi / 340 N/mm ² / 100 HB	
Magnesium &-Legierungen / Mg-alloys	Magnesium und -Legierungen / and -alloys		70 HB	
S	Warmfeste Legierungen heat-resistant alloys	Fe-Basis / Fe base	geglüht / annealed	99000 Psi / 680 N/mm ² / 200 HB
			ausgehärtet / cured	137750 Psi / 950 N/mm ² / 280 HB
		Ni- oder Co-Basis / Ni- or Co-Base	geglüht / annealed	122000 Psi / 840 N/mm ² / 250 HB
			ausgehärtet / cured	171000 Psi / 1180 N/mm ² / 350 HB
			gegossen / cast	156600 Psi / 1080 N/mm ² / 320 HB
	Titanlegierungen titanium alloys	Reintitan / pure titanium		58000 Psi / 400 N/mm ²
		Alpha- + Beta-Legierungen / -alloys	ausgehärtet / cured	152250 Psi / 1050 N/mm ²
H	Gehärteter Stahl hardened steel		gehärtet & angelassen / hardened & tempered	46-55 HRC
			gehärtet & angelassen / hardened & tempered	56-60 HRC
			gehärtet & angelassen / hardened & tempered	61-65 HRC
			gehärtet & angelassen / hardened & tempered	66-70 HRC
	Hartguss / chilled cast iron		gegossen / cast	400 HB
Gehärtetes Guss / hardened cast iron		gehärtet & angelassen / hardened & tempered	55 HRC	
O	Nichtmetallische Werkstoffe non-metallic materials	Kunststoffe, duroplastisch / plastics, duroplastic		≤ 21750 Psi / ≤ 150 N/mm ²
		Kunststoffe, thermoplastisch / plastics, thermoplastic		≤ 14500 Psi / ≤ 100 N/mm ²
		aramidfaserverstärkt / aramid fiber reinforced		≤ 145000 Psi / ≤ 1000 N/mm ²
		glas/kohlefaserverstärkt / glas/carbon fiber reinforced		≤ 145000 Psi / ≤ 1000 N/mm ²
		Graphit / graphite		

20 (10 - 50) best choice
20 (10 - 50) conditionally possible

The correct cutting speed must be selected depending on the dimension and application situation.

20 (10 - 50)
recommended starting value (preferred application area)

SYSTEM D-GROOVING

Einstechen mit ein- oder zweischneidigen Schneideinsätzen

grooving with one- or two-cutting edges inserts

Technische Hinweise

Schnittdatenempfehlung: metrisch

Schnittgeschwindigkeit: V_c (m/min)
Vorschub: f (mm/U)

Technical instructions, speed and feed recommendation: metric

cutting speed: V_c (m/min)
feed: f (mm/rev)

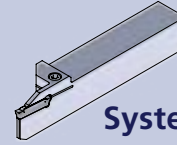

System D-Grooving

Werkstoffgruppe material group		Zusammensetzung composition		(Zug-)Festigkeit tensile strength	
ISO	Beschreibung / description	Gefüge / structure	Wärmebehandlung / heat treatment	Psi / N/mm ² (Rm) / HB / HRC	
P	Unlegierter Stahl unalloyed steel	ca. Japp. 0,15 % C	geglüht / annealed	61000 Psi / 420 N/mm ² / 125 HB	
		ca. Japp. 0,45 % C	geglüht / annealed	93000 Psi / 640 N/mm ² / 190 HB	
			vergütet / tempered	122000 Psi / 840 N/mm ² / 250 HB	
		ca. Japp. 0,75 % C	geglüht / annealed	132000 Psi / 910 N/mm ² / 270 HB	
			vergütet / tempered	146500 Psi / 1010 N/mm ² / 300 HB	
	Niedriglegierter Stahl low alloyed steel			geglüht / annealed	88500 Psi / 610 N/mm ² / 180 HB
				vergütet / tempered	135000 Psi / 930 N/mm ² / 275 HB
				vergütet / tempered	146500 Psi / 1010 N/mm ² / 300 HB
				vergütet / tempered	174000 Psi / 1200 N/mm ² / 375 HB
	Hochlegierter (Werkzeug)-Stahl highly alloyed steel			geglüht / annealed	99000 Psi / 680 N/mm ² / 200 HB
			gehärtet & angelassen / hardened & tempered	160000 Psi / 1100 N/mm ² / 300 HB	
Nichtrostender Stahl stainless steel			gehärtet & angelassen / hardened & tempered	189000 Psi / 1300 N/mm ² / 400 HB	
		ferritisch, martensitisch / ferritic, martensitic	geglüht / annealed	99000 Psi / 680 N/mm ² / 200 HB	
M	Nichtrostender Stahl stainless steel		abgeschreckt / quenched	88500 Psi / 610 N/mm ² / 200 HB	
			vergütet / tempered	300 HB	
				113000 Psi / 780 N/mm ² / 230 HB	
K	Grauguss cast iron			51000 Psi / 350 N/mm ² / 180 HB	
				72500 Psi / 500 N/mm ² / 260 HB	
	Gusseisen mit Kugelgraphit cast iron with nodular graphite			72500 Psi / 500 N/mm ² / 160 HB	
				122500 Psi / 845 N/mm ² / 250 HB	
				63800 Psi / 440 N/mm ² / 130 HB	
Temperguss malleable iron			113000 Psi / 780 N/mm ² / 230 HB		
N	Aluminium - Knetlegierungen wrought aluminum alloys			60 HB	
				49000 Psi / 340 N/mm ² / 100 HB	
	Aluminium - Gusslegierungen cast aluminum alloys			36250 Psi / 250 N/mm ² / 75 HB	
				43500 Psi / 300 N/mm ² / 90 HB	
				63800 Psi / 440 N/mm ² / 130 HB	
	Kupfer und Kupferlegierungen (Bronze / Messing) copper and copper alloys (bronze / brass)			54500 Psi / 375 N/mm ² / 110 HB	
			43500 Psi / 300 N/mm ² / 90 HB		
			49000 Psi / 340 N/mm ² / 100 HB		
Magnesium &-Legierungen / Mg-alloys			70 HB		
S	Warmfeste Legierungen heat-resistant alloys			99000 Psi / 680 N/mm ² / 200 HB	
				137750 Psi / 950 N/mm ² / 280 HB	
				122000 Psi / 840 N/mm ² / 250 HB	
				171000 Psi / 1180 N/mm ² / 350 HB	
				156600 Psi / 1080 N/mm ² / 320 HB	
	Titanlegierungen titanium alloys			58000 Psi / 400 N/mm ²	
				152250 Psi / 1050 N/mm ²	
H	Gehärteter Stahl hardened steel			46-55 HRC	
				56-60 HRC	
				61-65 HRC	
				66-70 HRC	
	Hartguss / chilled cast iron			400 HB	
Gehärtetes Guss / hardened cast iron			55 HRC		
O	Nichtmetallische Werkstoffe non-metallic materials			≤ 21750 Psi / ≤ 150 N/mm ²	
				≤ 14500 Psi / ≤ 100 N/mm ²	
				≤ 145000 Psi / ≤ 1000 N/mm ²	
				≤ 145000 Psi / ≤ 1000 N/mm ²	

Richtige Schnittgeschwindigkeit ist in Abhängigkeit von Dimension und Anwendungssituation zu wählen.

The correct cutting speed must be selected depending on the dimension and application situation.

20 (10 - 50) bevorzugte Wahl / best choice
20 (10 - 50) bedingt möglich / conditionally possible

20 (10 - 50)
empfohlener Startwert
recommended starting value

(bevorzugter Einsatzbereich)
(preferred application area)

Vorschub: [mm/U]

D-Grooving:
Einstechen/Abstechen: 0.05 - 0.35 mm/U
Längsdrehen ap < 70% von b*: 0.05 - 0.35 mm/U
Längsdrehen ap > 70% von b*: 0.04 - 0.28 mm/U

*b ≙ Breite Schneideinsatz

SYSTEM D-GROOVING

Einstecken mit ein- oder zweischneidigen Schneideinsätzen

grooving with one- or two-cutting edges inserts

Technische Hinweise

Schnittdatenempfehlung:

Technical instructions, speed and feed recommendation: imperial

cutting speed (SFM): V_c (feet/min)
feed: f (inch/rev)

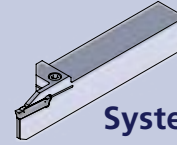

System D-Grooving

Werkstoffgruppe material group		Zusammensetzung composition		(Zug-)Festigkeit tensile strength	
ISO	Beschreibung / description	Gefüge / structure	Wärmebehandlung / heat treatment	Psi / N/mm ² (Rm) / HB / HRC	
P	Unlegierter Stahl unalloyed steel	ca.lapp. 0,15 % C	geglüht / annealed	61000 Psi / 420 N/mm ² / 125 HB	
		ca.lapp. 0,45 % C	geglüht / annealed	93000 Psi / 640 N/mm ² / 190 HB	
			vergütet / tempered	122000 Psi / 840 N/mm ² / 250 HB	
		ca.lapp. 0,75 % C	geglüht / annealed	132000 Psi / 910 N/mm ² / 270 HB	
			vergütet / tempered	146500 Psi / 1010 N/mm ² / 300 HB	
	Niedriglegierter Stahl low alloyed steel			geglüht / annealed	88500 Psi / 610 N/mm ² / 180 HB
				vergütet / tempered	135000 Psi / 930 N/mm ² / 275 HB
				vergütet / tempered	146500 Psi / 1010 N/mm ² / 300 HB
				vergütet / tempered	174000 Psi / 1200 N/mm ² / 375 HB
	Hochlegierter (Werkzeug-)Stahl highly alloyed steel			geglüht / annealed	99000 Psi / 680 N/mm ² / 200 HB
			gehärtet & angelassen / hardened & tempered	160000 Psi / 1100 N/mm ² / 300 HB	
Nichtrostender Stahl stainless steel			gehärtet & angelassen / hardened & tempered	189000 Psi / 1300 N/mm ² / 400 HB	
		ferritisch, martensitisch / ferritic, martensitic	geglüht / annealed	99000 Psi / 680 N/mm ² / 200 HB	
M	Nichtrostender Stahl stainless steel		vergütet / tempered	117500 Psi / 810 N/mm ² / 250 HB	
		austenitisch / austenitic	abgeschreckt / quenched	88500 Psi / 610 N/mm ² / 200 HB	
		austenitisch / austenitic	vergütet / tempered	300 HB	
K	Grauguss cast iron		austenitisch, ferritisch / ferritic, martensitic (Duplex)	113000 Psi / 780 N/mm ² / 230 HB	
			perlitisch, ferritisch / pearlitic, ferritic	51000 Psi / 350 N/mm ² / 180 HB	
	Gusseisen mit Kugelgraphit cast iron with nodular graphite		perlitisch (martensitisch) / pearlitic (martensitic)	72500 Psi / 500 N/mm ² / 260 HB	
			ferritisch / ferritic	72500 Psi / 500 N/mm ² / 160 HB	
Temperguss malleable iron		perlitisch / pearlitic	122500 Psi / 845 N/mm ² / 250 HB		
		ferritisch / ferritic	63800 Psi / 440 N/mm ² / 130 HB		
N	Aluminium - Knetlegierungen wrought aluminum alloys		perlitisch / pearlitic	113000 Psi / 780 N/mm ² / 230 HB	
			nicht aushärtbar / uncurable	60 HB	
	Aluminium - Gusslegierungen cast aluminum alloys		aushärtbar / curable	ausgehärtet / cured	49000 Psi / 340 N/mm ² / 100 HB
			≤ 12% Si, nicht aushärtbar / uncurable	ausgehärtet / cured	36250 Psi / 250 N/mm ² / 75 HB
			≤ 12% Si, aushärtbar / curable	ausgehärtet / cured	43500 Psi / 300 N/mm ² / 90 HB
	Kupfer und Kupferlegierungen (Bronze / Messing) copper and copper alloys (bronze / brass)		> 12% Si, nicht aushärtbar / uncurable	ausgehärtet / cured	63800 Psi / 440 N/mm ² / 130 HB
		PB > 1 %, Automatenlegierungen / free cutting alloys	ausgehärtet / cured	54500 Psi / 375 N/mm ² / 110 HB	
		CuZn, CuSnZn	ausgehärtet / cured	43500 Psi / 300 N/mm ² / 90 HB	
Magnesium &-Legierungen / Mg-alloys		CuSn, bleifrei & Elektrolytisch / lead free & electrolytic	ausgehärtet / cured	49000 Psi / 340 N/mm ² / 100 HB	
		Magnesium und -Legierungen / and -alloys	ausgehärtet / cured	70 HB	
S	Warmfeste Legierungen heat-resistant alloys		Fe-Basis / Fe base	geglüht / annealed	99000 Psi / 680 N/mm ² / 200 HB
				ausgehärtet / cured	137750 Psi / 950 N/mm ² / 280 HB
			Ni- oder Co-Basis / Ni- or Co-Base	geglüht / annealed	122000 Psi / 840 N/mm ² / 250 HB
				ausgehärtet / cured	171000 Psi / 1180 N/mm ² / 350 HB
	Titanlegierungen titanium alloys			gegossen / cast	156600 Psi / 1080 N/mm ² / 320 HB
			Reintitan / pure titanium	ausgehärtet / cured	58000 Psi / 400 N/mm ²
H	Gehärteter Stahl hardened steel		Alpha- + Beta-Legierungen / -alloys	ausgehärtet / cured	152250 Psi / 1050 N/mm ²
			Beta-Legierungen / -alloys	ausgehärtet / cured	203000 Psi / 1400 N/mm ² / 410 HB
				gehärtet & angelassen / hardened & tempered	46-55 HRC
O	Nichtmetallische Werkstoffe non-metallic materials			gehärtet & angelassen / hardened & tempered	56-60 HRC
				gehärtet & angelassen / hardened & tempered	61-65 HRC
				gehärtet & angelassen / hardened & tempered	66-70 HRC
				gehärtet & angelassen / hardened & tempered	66-70 HRC
	Hartguss / chilled cast iron		gegossen / cast	400 HB	
	Gehärtetes Guss / hardened cast iron		gehärtet & angelassen / hardened & tempered	55 HRC	
		Kunststoffe, duroplastisch / plastics, duroplastic		≤ 21750 Psi / ≤ 150 N/mm ²	
		Kunststoffe, thermoplastisch / plastics, thermoplastic		≤ 14500 Psi / ≤ 100 N/mm ²	
		aramidfaserverstärkt / aramid fiber reinforced		≤ 145000 Psi / ≤ 1000 N/mm ²	
		glas/kohlefaserverstärkt / glas/carbon fiber reinforced		≤ 145000 Psi / ≤ 1000 N/mm ²	
		Graphit / graphite			

The correct cutting speed must be selected depending on the dimension and application situation.

20 (10 - 50) best choice
20 (10 - 50) conditionally possible

20 (10 - 50) recommended starting value (preferred application area)

feed f: [inch/rev]

D-Grooving:
grooving / parting: 0.0020 - 0.0138 mm/rev
turning ap < 70% of b* 0.0020 - 0.0138 mm/rev
turning ap > 70% of b* 0.0016 - 0.0110 mm/rev

*b ≙ width of insert



duemmel.de



NUTSTOSSEN

$B \geq 2.0 \text{ mm}$

$D \text{ min.} \geq \text{Ø } 6.0 \text{ mm}$

$SW \geq 1.0 \text{ mm}$

NUTSTOSEN

Herstellung von Längsnuten
und Innenprofilen

broaching keyways
and internal profiles

Übersicht

summary

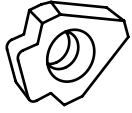

Allgemeine Beschreibung

general instructions

... 6

Ø 6 mm

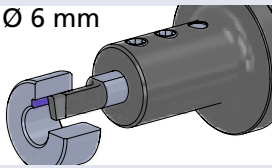

**Nutstossen
ab D min. 6 mm**

**Klemmhalter Typ NHU und
Schneideinsatz Typ NPU**

**broaching keyways
starting D min. 6 mm**

**toolholder type NHU and
insert type NPU**

**Maße
dimensions
[mm]**

**Seite
page**

Typ NHU

Klemmhalter

toolholder

D min. 6

... 7

Typ NHU

Klemmhalter
für angetriebene Stosswerkzeuge

toolholder
for driven slotting tool

D min. 6

... 8

Typ NPU

Schneideinsatz
Toleranzklasse P9 / JS9

insert
tolerance grade P9 / JS9

D min. 6 - 7
B = 2 - 5

... 9

Typ NPU

Schneideinsatz
Toleranzklasse H9 / D9 / C11

insert
tolerance grade H9 / D9 / C11

D min. 6 - 7
B = 2 - 5

...10

Typ NPU. ...45

Schneideinsatz
Fasen 45°

insert
chamfering 45°

D min. 9

... 11

Ø 10 mm

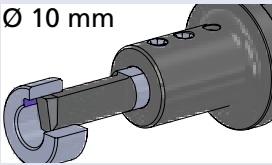

**Nutstossen
D min. 10 mm**

**Klemmhalter Typ NH10 und
Schneideinsatz Typ NP10**

**broaching keyways
D min. 10 mm**

**toolholder type NH10 and
insert type NP10**

**Maße
dimensions
[mm]**

**Seite
page**

Typ NH10

Klemmhalter

toolholder

D min. 10

... 12

Typ NP10

Schneideinsatz
Toleranzklasse P9 / JS9

insert
tolerance grade P9 / JS9

D min. 10
B = 3 - 6

... 13

Typ NP10

Schneideinsatz
Toleranzklasse H9 / C11

insert
tolerance grade H9 / C11

D min. 10
B = 4 - 6

... 14

Ø 10 mm

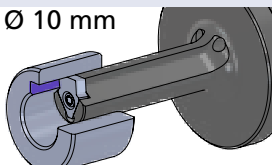

**Nutstossen
D min. 10 mm**

**Klemmhalter Typ NHV.10 und
Schneideinsatz Typ NV10**

**broaching keyways
D min. 10 mm**

**toolholder type NHV.10 and
insert type NV10**

**Maße
dimensions
[mm]**

**Seite
page**

Typ NHV.10

Klemmhalter
mit Innenkühlung

toolholder
with internal cooling

D min. 10

... 15

Typ NV10

Schneideinsatz
Nuttiefe bis 2.8 mm
Toleranzklasse P9 / JS9 / D9

insert
depth of groove up to 2.8
tolerance grade P9 / JS9 / D9

D min. 10
B = 3 - 5

... 16

NUTSTOSSEN

Herstellung von Längsnuten
und Innenprofilen

broaching keyways
and internal profiles

Übersicht

summary

 Ø 15 mm	Nutstossen D min. 15 mm	broaching keyways D min. 15 mm	Maße dimensions [mm]	Seite page
	Klemmhalter Typ NHV.15 und Schneideinsatz Typ NV15	toolholder type NHV.15 and insert type NV15		
Typ NHV.15.IK25	Klemmhalter mit Innenkühlung	toolholder with internal cooling	D min. 15	... 17
Typ NHV.15	Klemmhalter für angetriebene Stosswerkzeuge	toolholder for driven slotting tool	D min. 15	... 18
Typ NV15	Schneideinsatz Nuttiefe bis 3.3 mm Toleranzklasse P9 / JS9 / D9 C11 / inch	insert depth of groove up to 3.3 tolerance grade P9 / JS9 / D9 C11 / inch	D min. 15 B = 4 - 6	... 19
Typ NV15. ...45.1	Schneideinsatz Fasen 45°	insert chamfering 45°	D min.15 B = 5 - 8	... 26
 Ø 22 mm	Nutstossen ab D min. 22 mm	broaching keyways starting D min. 22 mm	Maße dimensions [mm]	Seite page
	Klemmhalter Typ NHV und Schneideinsatz Typ NPV	toolholder type NHV and insert type NPV		
Typ NHV.22 Typ NHV.30 Typ NHV.38 Typ NHV.45	Klemmhalter mit Innenkühlung	toolholder with internal cooling	D min. 22 D min. 30 D min. 38 D min. 45	... 20
Typ NHV.22 Typ NHV.30	Klemmhalter für angetriebene Stosswerkzeuge	toolholder for driven slotting tool	D min. 22 D min. 30	... 21
Typ NPV	Schneideinsatz Nuttiefe bis 10 mm Toleranzklasse P9	insert depth of groove up to 10 mm tolerance grade P9	B = 5 - 20	... 22
Typ NPV	Schneideinsatz Nuttiefe bis 10 mm Toleranzklasse JS9	insert depth of groove up to 10 mm tolerance grade JS9	B = 5 - 20	... 23
Typ NPV	Schneideinsatz Nuttiefe bis 10 mm Toleranzklasse H9 / D9	insert depth of groove up to 10 mm tolerance grade H9 / D9	B = 5 - 20	... 24
Typ NPV	Schneideinsatz Nuttiefe bis 8.5 mm Toleranzklasse C11 / inch	insert depth of groove up to 8.5 mm tolerance grade C11 / inch	B = 6 - 12	... 25
Typ NPV. ...45.1	Schneideinsatz Fasen 45°	insert chamfering 45°	D min. 22 / 38 B = 6 - 12	... 26



NUTSTOSSEN

Herstellung von Längsnuten
und Innenprofilen

broaching keyways
and internal profiles

Übersicht

summary

SW 1.0-32

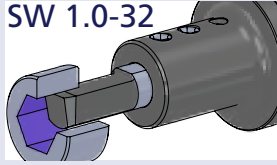

Nutstossen
Schlüsselweite SW 1.0 - 32
und Vierkant

broaching keyways
wrench size SW 1.0 - 32
and square bore

Maße
dimensions
[mm]

Seite
page

Typ NPU.SW

Schneideinsatz
für Innensechskant

insert
for hexagon socket

SW 2.5 - 8

... 27

Typ NPU.SW

Schneideinsatz 120°
für Innensechskant

insert 120°
for hexagon socket

SW 1.0 - 8.0

... 28

Typ NP10.SW

Schneideinsatz
für Innensechskant

insert
for hexagon socket

SW 10 - 16

... 29

Typ NHV....SW25
Typ NHV....90

Klemmhalter
für Sechskant und Vierkant
mit Innenkühlung

toolholder
for hexagon socket and square bore
with internal cooling

D min. 13/14/20
SW 13 - 32
□ 14 , □ 20

... 30

Typ NV15.SW13
Typ NPV.SW20
Typ NV15.90
Typ NPV.90

Schneideinsatz
für Sechskant und Vierkant

insert
for hexagon socket and square bore

D min. 13/14/20
SW 13 - 32
□ 14 , □ 20

... 31

Typ NHV....VZ ...

Klemmhalter
für Verzahnungen,
mit Innenkühlung

toolholder
for gears,
with internal cooling

D min.
10 / 15 / 22 / 30

... 32



NUTSTOSSEN

Herstellung von Längsnuten
und Innenprofilen

broaching keyways
and internal profiles

Übersicht

summary



Sets Nutstossen

sets broaching keyways

Maße
dimensions
[mm]

Seite
page

Halter und Schneiden

toolholder and inserts

SET - NPU

Auswahl
Toleranzklasse JS9

selection
tolerance grade JS9

D min. 6
B = 2 / 3 / 4

... 33

SET - NP10

Auswahl
Toleranzklasse JS9

selection
tolerance grade JS9

D min. 10
B = 4 / 5

... 33

SET - NPV

Auswahl
Toleranzklasse JS9

selection
tolerance grade JS9

D min. 22 / 30
B = 5.01 / 6.01
/ 8.01

... 34

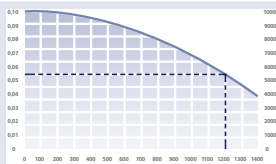

Technische Hinweise

Technical Instructions

Seite
page

Grundsätzliche Informationen zum
Nutstossen

Basic informations about
broaching keyways

... 35

Hartmetallsorten und Beschichtungen

carbide grades and coatings

... 36

Schnittdatenempfehlung

speed and feed recommendation

... 38



NUTSTOSSEN

Herstellung von Längsnuten
und Innenprofilen

broaching keyways
and internal profiles

Allgemeine Beschreibung

Stossen von Innennuten
auf CNC-Maschinen

general instructions,
broaching keyways
on CNC machines

Komplettbearbeitung auf CNC-Drehmaschinen
und Fräszentren ohne Umspannen.
Einfach und wirtschaftlich.

Complete machining on CNC turning- and milling centres
in one clamping.
Simple and efficient.



NUTSTOSEN

Herstellung von Längsnuten und Innenprofilen

broaching keyways and internal profiles

Typ NHU

Klemmhalter

D min. 6 mm

toolholder

D min. 6 mm

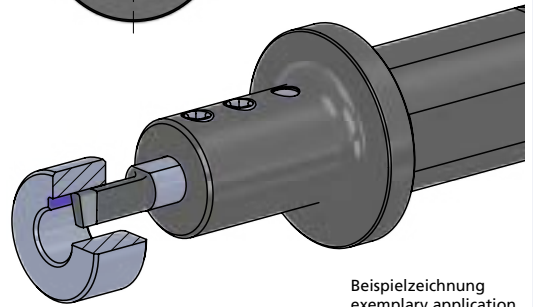
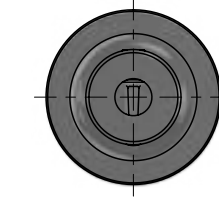
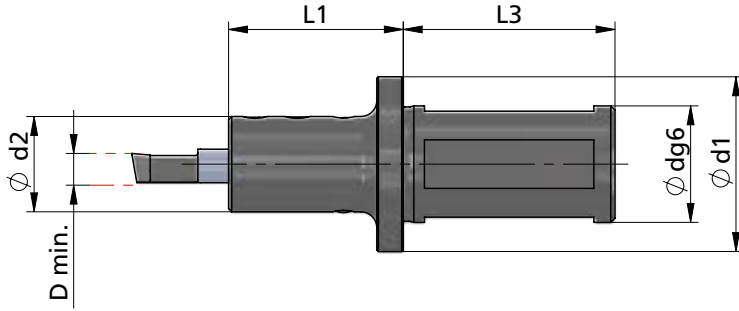

Beispielzeichnung
exemplary application

Abmessungen in mm

dimensions in mm

Bestellnummer part number	D min.	Ø d g6 x L3 Aufnahme clamping part	Ø d (inch)	L1	Ø d1	Ø d2	Spannschraube screw	Schrauben- schlüssel wrench	Anzugs- drehmoment torque	für Schneidplatte for insert
NHU.0020.1	6	Ø20 x 40		33	33	18	A.GST004	111.645	1.2 Nm	NPU...
NHU.0022.1	6	Ø22 x 40		33	33	18				
NHU.0025.1	6	Ø25 x 40		33	33	18				
NHU.00254.1	6	Ø25.4 x 40	1"	33	33	18				
NHU.0032.1	6	Ø32 x 40		33	40	20				



Bestellbeispiel:
NHU.0020.1

order-example:
NHU.0020.1

NUTSTOSSEN

Herstellung von Längsnuten und Innenprofilen

broaching keyways and internal profiles

Typ NHU

Klemmhalter für angetriebene Stosswerkzeuge

D min. 6 mm

toolholder for driven slotting tool

D min. 6 mm

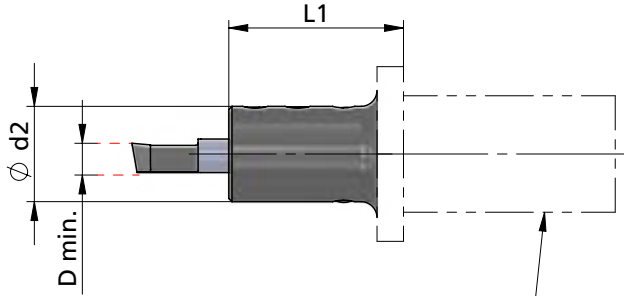

Aufnahme nach Herstellerangaben

clamping part according to manufacture's specification

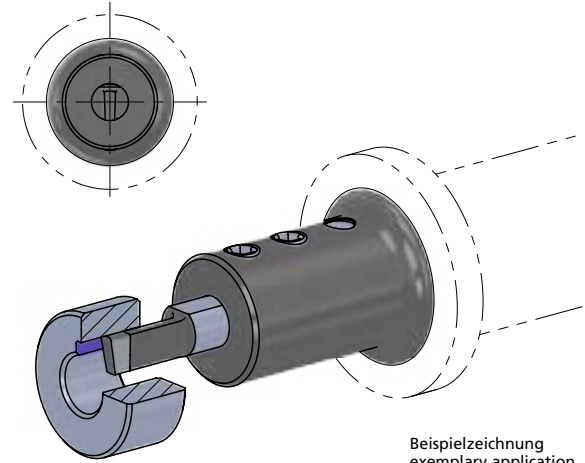

Beispielzeichnung
exemplary application

Abmessungen in mm

dimensions in mm



Bestellnummer part number	D min.	Aufnahme nach Herstellerangabe clamping part acc. to manufac. specification	L1	Ø d2	für Nutstoss- geräte for broaching device	Spannschraube screw	Schrauben- schlüssel wrench	Anzugs- drehmoment torque	für Schneidplatte for insert
NHU.0012.1	6	Ø12 x 25	32	20	Schwarzer 1				
NHU.0015.1	6	Ø15 x 33	37	18	Schwarzer 2 in 1				
NHU.0016.1	6	Ø16 x 30	33	18	EWS Slot + Benz LinA				
NHU.MP16.1	6	Ø16 x 34	33	18	Mario Pinto Stoßeinheit	A.GST004	111.645	1.2 Nm	NPU,...
NHU.MT16.1	6	Ø16 x 25	33	18	MT Marchetti				
NHU.WT16.1	6	Ø16 x 6	36	18	WTO Stoßeinheit				
NHU.0020.1.IK*	6	Ø20 x 39.5	34	18	EWS Slot P20 / incl. IKZ + Benz LinA 4.0 / incl. IKZ				



NUTSTOSEN

Herstellung von Längsnuten und Innenprofilen

broaching keyways and internal profiles

Typ NPU

Schneideinsatz
Toleranzklasse P9 / JS9

D min. 6 - 7 mm

insert
tolerance grade P9 / JS9

D min. 6 - 7 mm



NPU.0... ..

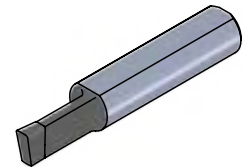
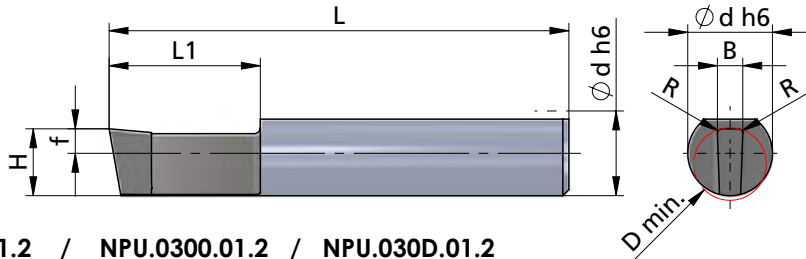

NPU.0298.01.2 / NPU.0300.01.2 / NPU.030D.01.2

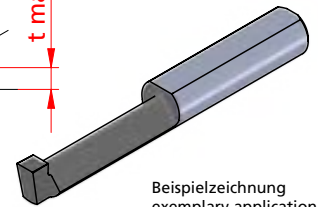
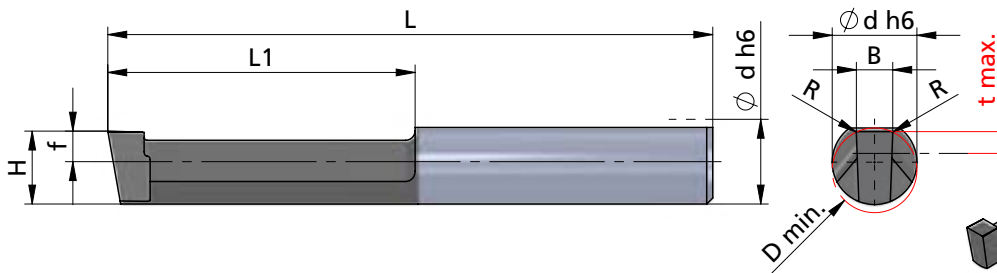

Beispielzeichnung
exemplary application

Abmessungen in mm

dimensions in mm

Bestellnummer part number	Nenngröße nominal size	Schneideinsatz nach DIN insert according DIN	D min.	B	R	H +0.05	f	L	L1	Ø d h6	t max.	K10F AL41F P18C	für Klemmhalter for toolholder type
NPU.0198.01.1	2		6	1.98	0.1	5.5	2.0	38	12.5	7	-	●	NHU... 
NPU.0298.01.1	3	p9	7	2.98	0.1	6.2	2.7	38	12.5	7	-	●	
NPU.0298.01.2	3	DIN 6885	7	2.98	0.1	6.0	2.5	50	25	7	1.8	●	
NPU.0398.01.1	4	fester Sitz strong fit	7	3.98	0.1	6.2	2.7	40	15	7	-	●	
NPU.0398.02.2	4		7	3.98	0.2	6.2	2.7	50	25	7	-	●	
NPU.0498.02.2	5		7	4.98	0.2	5.8	2.3	50	25	7	-	●	
NPU.0200.01.1	2		6	2.00	0.1	5.5	2.0	38	12.5	7	-	●	
NPU.0300.01.1	3		7	3.00	0.1	6.2	2.7	38	12.5	7	-	●	
NPU.0300.01.2	3	JS9 DIN 6885	7	3.00	0.1	6.0	2,5	50	25	7	1.8	●	
NPU.0400.01.1	4		7	4.00	0.1	6.2	2.7	40	15	7	-	●	
NPU.0400.02.1	4	leichter Sitz slightly fit	7	4.00	0.2	6.2	2.7	40	15	7	-	●	
NPU.0400.02.2	4		7	4.00	0.2	6.2	2.7	50	25	7	-	●	
NPU.0500.02.2	5		7	5.00	0.2	5.8	2.3	50	25	7	-	●	

Weitere HM Sorten können Sie in der Sortenübersicht im Kapitel "Technische Hinweise" und der Preisliste finden.

Bestellbeispiel:
für Sorte AL41F:
NPU.0198.01.1/AL41F

More carbide grades you can find in the grades summary in the chapter "technical instructions" and in the price list.

order-example:
grade AL41F:
NPU.0198.01.1/AL41F

NUTSTOSSEN

Herstellung von Längsnuten
und Innenprofilen

broaching keyways
and internal profiles

Typ NPU

Schneideinsatz
Toleranzklasse H9 / D9 / C11

D min. 6 - 7 mm

insert
tolerance grade H9 / D9 / C11

D min. 6 - 7 mm

NPU.0... ..

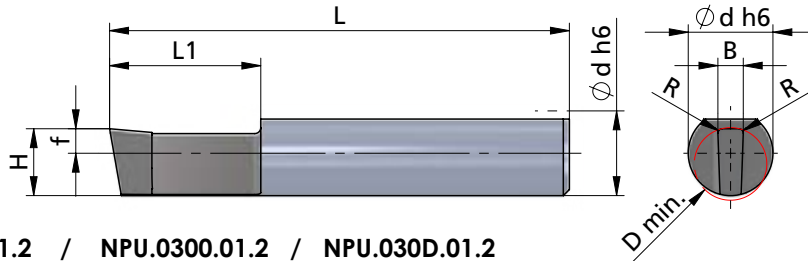

NPU.0298.01.2 / NPU.0300.01.2 / NPU.030D.01.2

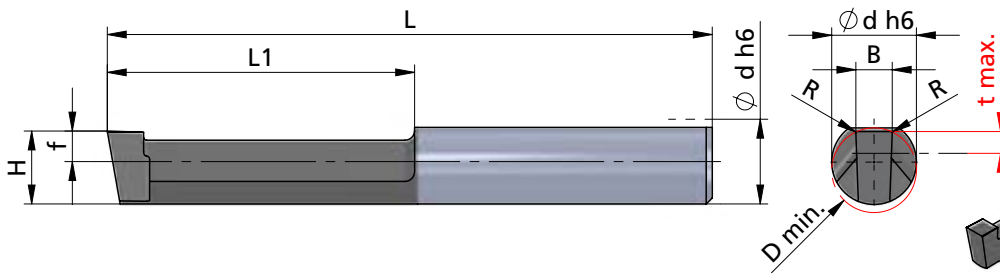

Beispielzeichnung
exemplary application

Abmessungen in mm

dimensions in mm

Bestellnummer part number	Nenngröße nominal size	Schneideinsatz nach DIN insert according DIN	D min.	B	R	H +0.05	f	L	L1	Ø d h6	t max.	K10F AL41F P18C	für Klemmhalter for toolholder type
NPU.020H.01.1	2	H9 DIN 6885	6	2.02	0.1	5.5	2.0	38	12.5	7	-	●	NHU...
NPU.030H.01.1	3		7	3.02	0.1	6.2	2.7	38	12.5	7	-	●	
NPU.040H.01.1	4		7	4.02	0.1	6.2	2.7	40	15	7	-	●	
NPU.040H.02.2	4		7	4.02	0.2	6.2	2.7	50	25	7	-	●	
NPU.050H.02.2	5		7	5.02	0.2	5.8	2.3	50	25	7	-	●	
NPU.020D.01.1	2	D9 DIN 6885 Gleitsitz sliding fit	6	2.035	0.1	5.5	2.0	38	12.5	7	-	●	
NPU.030D.01.2	3		7	3.035	0.1	6.2	2.7	50	25	7	1.8	●	
NPU.040D.01.1	4		7	4.035	0.1	6.2	2.7	40	15	7	-	●	
NPU.040D.02.2	4		7	4.035	0.2	6.2	2.7	50	25	7	-	●	
NPU.050D.02.2	5		7	5.035	0.2	5.8	2.3	50	25	7	-	●	
NPU.0210.03.1	2	C11 DIN 138 Standard	6	2.1	0.35	5.5	2.0	38	12.5	7	-	●	
NPU.0310.03.1	3		7	3.1	0.35	6.2	2.7	38	12.5	7	-	●	
NPU.0310.05.1	3		7	3.1	0.5	6.2	2.7	38	12.5	7	-	●	
NPU.0410.05.1	4		7	4.1	0.5	6.2	2.7	40	15	7	-	●	
NPU.0410.05.2	4		7	4.1	0.5	6.2	2.7	50	25	7	-	●	

Weitere HM Sorten können Sie in der Sortenübersicht im Kapitel "Technische Hinweise" und der Preisliste finden.

Bestellbeispiel:
für Sorte AL41F:
NPU.020H.01.1/AL41F

More carbide grades you can find in the grades summary in the chapter "technical instructions" and in the price list.

order-example:
grade AL41F:
NPU.020H.01.1/AL41F

NUTSTOSSEN

Herstellung von Längsnuten
und Innenprofilen

broaching keyways
and internal profiles

Typ NPU. ... 45

Schneideinsatz
Fasen 45°

D min. 9 mm

insert
chamfering 45°

D min. 9 mm

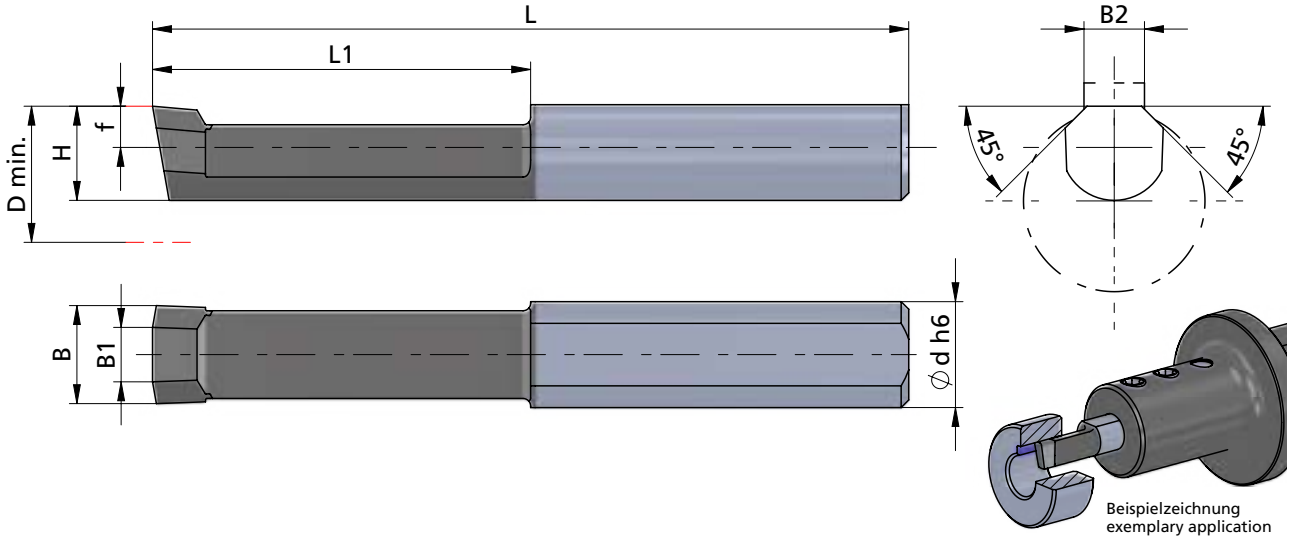

Abmessungen in mm

dimensions in mm

Bestellnummer part number	D min.	B	B1	B2 Nutenbreite width of groove	H +0.05	f	L	L1	Ø d h6	für Klemmhalter for toolholder type		
										K10F	AL41F	P18C
NPU.4545.1	9	6.5	3.6	4 - 5	6.2	2.7	50	25	7	●		NHU...



Weitere HM Sorten können Sie in der Sortenübersicht im Kapitel "Technische Hinweise" und der Preisliste finden.

Bestellbeispiel:
für Sorte AL41F:
NPU.4545.1/AL41F

More carbide grades you can find in the grades summary in the chapter "technical instructions" and in the price list.

order-example:
grade AL41F:
NPU.4545.1/AL41F

NUTSTOSEN

Herstellung von Längsnuten und Innenprofilen

broaching keyways and internal profiles

Typ NH10

Klemmhalter

D min. 10 mm

toolholder

D min. 10 mm

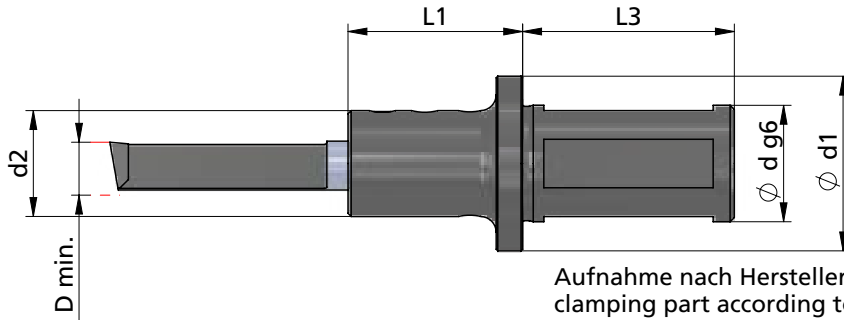

Aufnahme nach Herstellerangaben
clamping part according to
manufacture's specification

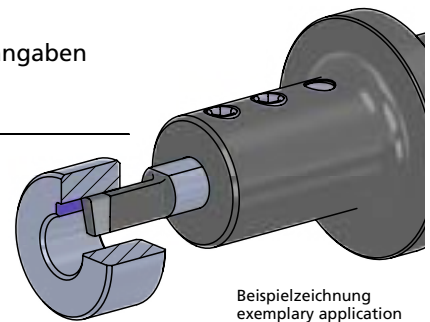
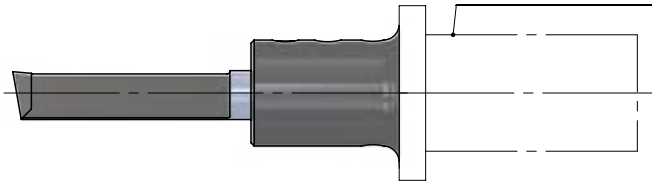

Beispielzeichnung
exemplary application

Abmessungen in mm

dimensions in mm



*

Bestellnummer part number	D min.	Ø d g6 x L3 Aufnahme clamping part	L1	Ø d1	Ø d2		Spannschraube screw	Schrauben- schlüssel wrench	Anzugs- drehmoment torque	für Schneid- platte for insert
NH10.0020.1	10	Ø20 x 40	33	33	20					
NH10.0022.1	10	Ø22 x 40	33	33	20					
NH10.0025.1	10	Ø25 x 40	33	33	20		A.GST001	111.INB3	2.5 Nm	NP10...
NH10.0032.1	10	Ø32 x 40	33	40	20					
Bestellnummer part number	D min.	Aufnahme nach Hersteller- angabe clamping part acc.to manufac. specification			Ø d2	für Nutstoss- geräte for broaching device	Spannschraube screw	Schrauben- schlüssel wrench	Anzugs- drehmoment torque	für Schneid- platte for insert
NH10.0012.1	10	Ø12 x 25	32		20	Schwarzer 1				
NH10.0015.1	10	Ø15 x 33	37		18	Schwarzer 2 in 1				
NH10.0016.1	10	Ø16 x 30	33		18	EWS Slot + Benz LinA				
NH10.0020.1.IK*	10	Ø20 x 39.5	34		18	EWS Slot P20 / incl. IKZ + Benz LinA 4.0 / incl. IKZ	A.GST001	111.INB3	2.5 Nm	NP10...
NH10.MP16.1	10	Ø16 x 34	33		20	Mario Pinto Stoßeinheit				
NH10.MT16.1	10	Ø16 x 25	33		18	MT Marchetti				
NH10.WT16.1	10	Ø16 x 6	36		20	WTO Stoßeinheit				

NUTSTOSSEN

Herstellung von Längsnuten und Innenprofilen

broaching keyways and internal profiles

Typ NP10

Schneideinsatz
Toleranzklasse P9 / JS9

D min. 10 mm

insert
tolerance grade P9 / JS9

D min. 10 mm

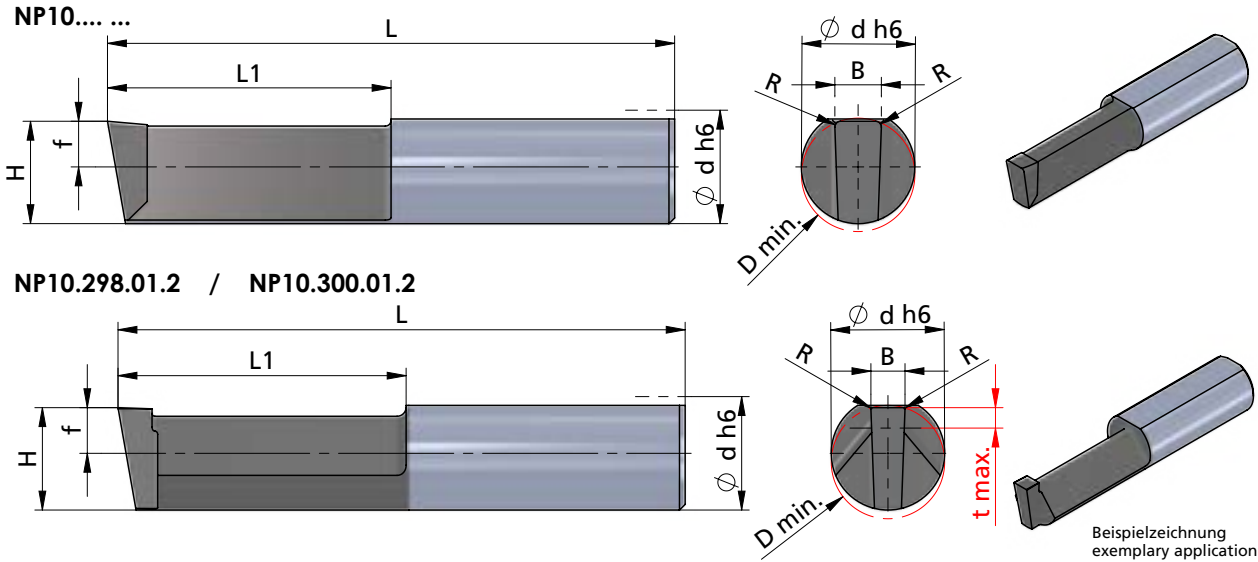

Beispielzeichnung
exemplary application

Abmessungen in mm

dimensions in mm

Bestellnummer part number	Nenngröße nominal size	Schneideinsatz nach DIN insert according DIN	D min.	B	R	H +0.05	f	L	L1	Ø d h6	t max.	K10F	AL41F	P18C	für Klemmhalter for toolholder type
NP10.298.01.2	3		10	2.98	0.1	9	4	50	25	10	1.8	●			NH10...
NP10.398.02.2	4	p9	10	3.98	0.2	9	4	50	25	10	-	●			
NP10.398.02.3	4	DIN 6885	10	3.98	0.2	9	4	66	41	10	-	●			
NP10.498.02.2	5	fester Sitz strong fit	10	4.98	0.2	9	4	50	25	10	-	●			
NP10.498.02.3	5		10	4.98	0.2	9	4	66	41	10	-	●			
NP10.598.02.3	6		10	5.98	0.2	8.5	3.5	66	41	10	-	●			
NP10.300.01.2	3		10	3.0	0.1	9	4	50	25	10	1.8	●			
NP10.400.02.2	4	JS9	10	4.0	0.2	9	4	50	25	10	-	●			
NP10.400.02.3	4	DIN 6885	10	4.0	0.2	9	4	66	41	10	-	●			
NP10.500.02.2	5	leichter Sitz slightly fit	10	5.0	0.2	9	4	50	25	10	-	●			
NP10.500.02.3	5		10	5.0	0.2	9	4	66	41	10	-	●			
NP10.600.02.3	6		10	6.0	0.2	8.5	3.5	66	41	10	-	●			
↳ ...															

Weitere HM Sorten können Sie in der Sortenübersicht im Kapitel "Technische Hinweise" und der Preisliste finden.

Bestellbeispiel:
für Sorte AL41F:
NP10.298.01.2/AL41F

More carbide grades you can find in the grades summary in the chapter "technical instructions" and in the price list.

order-example:
grade AL41F:
NP10.298.01.2/AL41F



NUTSTOSSEN

Herstellung von Längsnuten
und Innenprofilen

broaching keyways
and internal profiles

Typ NP10

Schneideinsatz
Toleranzklasse H9 / C11

D min. 10 mm

insert
tolerance grade H9 / C11

D min. 10 mm

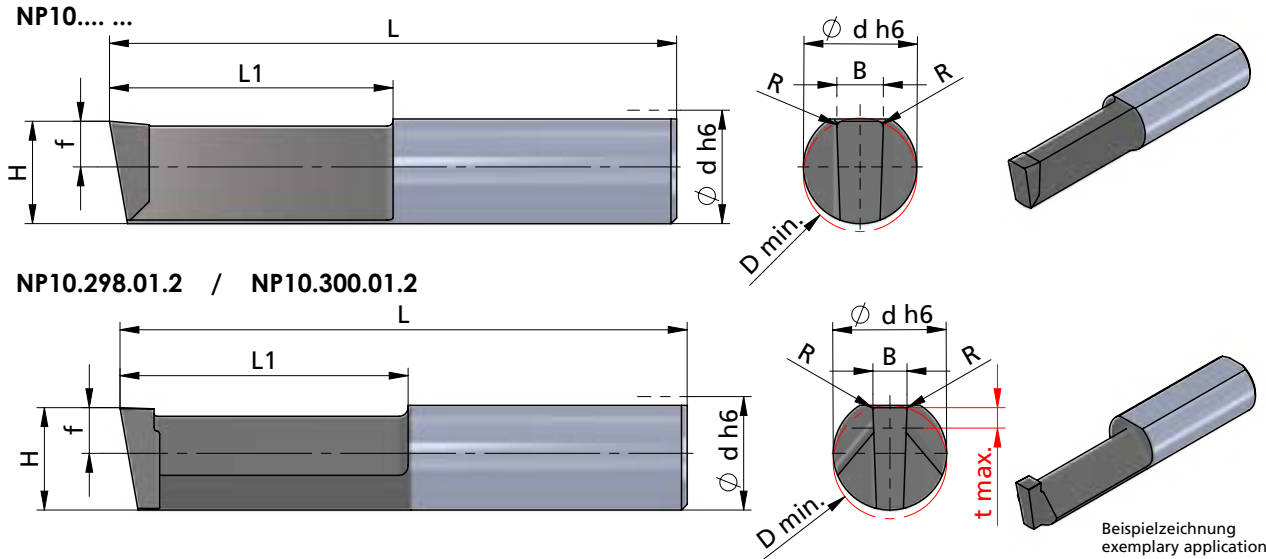

Beispielzeichnung
exemplary application

Abmessungen in mm

dimensions in mm

Bestellnummer part number	Nenngröße nominal size	Schneideinsatz nach DIN insert according DIN	D min.	B	R	H +0.05	f	L	L1	Ø d h6	t max.	K10F	AL41F	P18C	für Klemhalter for toolholder type
NP10.040H.02.2	4		10	4.02	0.2	9	4	50	25	10	-	●			NH10...
NP10.040H.02.3	4		10	4.02	0.2	9	4	66	41	10	-	●			
NP10.050H.02.2	5	H9 DIN 6885	10	5.02	0.2	9	4	50	25	10	-	●			
NP10.050H.02.3	5		10	5.02	0.2	9	4	66	41	10	-	●			
NP10.060H.02.3	6		10	6.02	0.2	8.5	3.5	66	41	10	-	●			
NP10.410.05.2	4		10	4.1	0.5	9	4	50	25	10	-	●			
NP10.410.05.3	4	C11 DIN 138	10	4.1	0.5	9	4	66	41	10	-	●			
NP10.510.05.2	5		10	5.1	0.5	9	4	50	25	10	-	●			
NP10.510.05.3	5	Standard	10	5.1	0.5	9	4	66	41	10	-	●			

Weitere HM Sorten können Sie in der Sorten-
übersicht im Kapitel "Technische Hinweise" und
der Preisliste finden.

More carbide grades you can find in the grades
summary in the chapter "technical instructions"
and in the price list.

NUTSTOSEN

Herstellung von Längsnuten und Innenprofilen

broaching keyways and internal profiles

Typ NHV.10

Klemmhalter mit Innenkühlung

toolholder with internal cooling

D min. 10 mm

D min. 10 mm

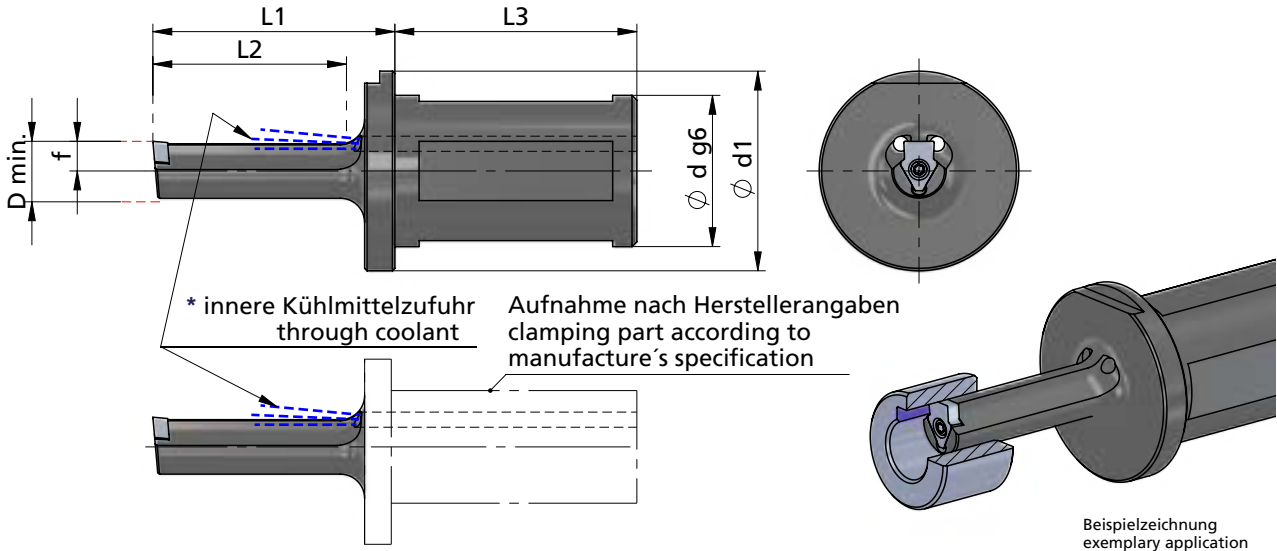

Abmessungen in mm

dimensions in mm



Bestellnummer part number	D min.	Ø d g6 x L3 Aufnahme clamping part	L1	L2	f	Ø d1	Spannschraube screw	Schraubenschlüssel wrench	Anzugs- drehmoment torque	für Schneidplatte for insert
NHV.10.IK25.1*	10	Ø25 x 40	30	22	4.9	33				
NHV.10.IK25.2*	10	Ø25 x 40	40	32	4.9	33	A.SPS018	T6F	0.6 Nm	NV10,...
NHV.10.IK25.3*	10	Ø25 x 40	50	42	4.9	33				

Bestellnummer part number	D min.	Aufnahme nach Herstellerangabe clamping part acc. to manufac. specification	für Nutstossergeräte for broaching device		Spannschraube screw	Schraubenschlüssel wrench	Anzugs- drehmoment torque	für Schneidplatte for insert
NHV.10.0016.1	10	Ø16 x 30	46	36				
NHV.10.MT16.1	10	Ø16 x 25	40	30				
NHV.10.WT16.1	10	Ø16 x 6	49	35	A.SPS018	T6F	0.6 Nm	NV10,...
NHV.10.0020.1.IK*	10	Ø20 x 39.5	46	36				

Bestellbeispiel:
NHV.10.IK25.1

order-example:
NHV.10.IK25.1

NUTSTOSSEN

Herstellung von Längsnuten
und Innenprofilen

broaching keyways
and internal profiles

Typ NV10

Schneideinsatz
Nuttiefe bis 2.8
Toleranzklasse P9 / JS9 / D9

D min. 10 mm

insert
depth of groove up to 2.8
tolerance grade P9 / JS9 / D9

D min. 10 mm

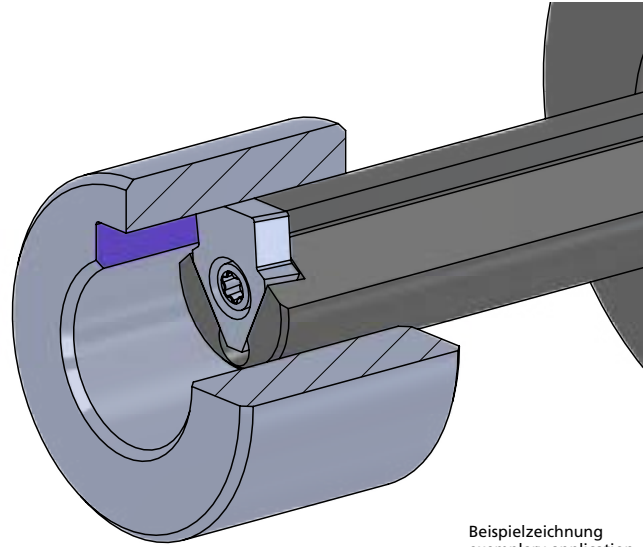
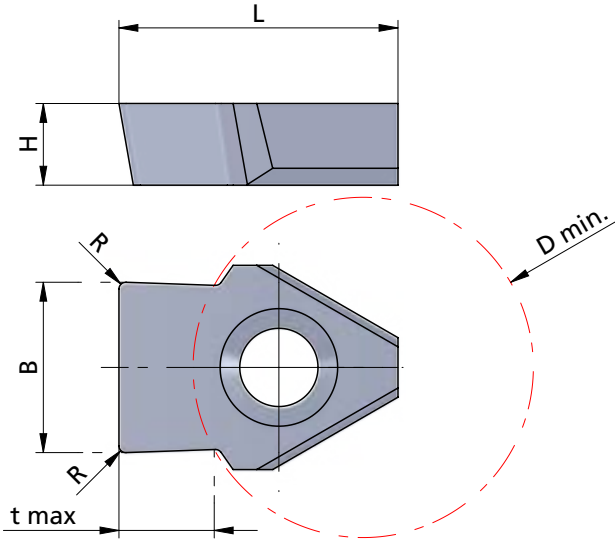

Beispielzeichnung
exemplary application

Abmessungen in mm

dimensions in mm

Bestellnummer part number	Nenngröße nominal size	Schneideinsatz nach DIN insert according DIN	D min.	B	R	L	t max.	H	für Klemhalter for toolholder type			
									K10F	AL41F	P18C	
NV10.0298.02	3	P9	10	2.98	0.2	8.2	1.8	2.4	●	●	●	NHV.10....
NV10.0398.02	4	DIN 6885 fester Sitz	10	3.98	0.2	8.2	2.3	2.4	●	●	●	
NV10.0498.02	5	strong fit	10	4.98	0.2	8.2	2.8	2.4	●	●	●	
NV10.0301.02	3	JS9	10	3.01	0.2	8.2	1.8	2.4	●	●	●	
NV10.0401.02	4	DIN 6885 leichter Sitz	10	4.01	0.2	8.2	2.3	2.4	●	●	●	
NV10.0501.02	5	slightly fit	10	5.01	0.2	8.2	2.8	2.4	●	●	●	
NV10.030D.02	3	D9	10	3.035	0.2	8.2	1.8	2.4	●	●	●	
NV10.040D.02	4	DIN 6885 Gleitsitz	10	4.05	0.2	8.2	2.3	2.4	●	●	●	
NV10.050D.02	5	sliding fit	10	5.05	0.2	8.2	2.8	2.4	●	●	●	

Weitere HM Sorten können Sie in der Sorten-
übersicht im Kapitel "Technische Hinweise" und
der Preisliste finden.

More carbide grades you can find in the grades
summary in the chapter "technical instructions"
and in the price list.

NUTSTOSEN

Herstellung von Längsnuten und Innenprofilen

broaching keyways and internal profiles

Typ NHV.15.IK25

Klemmhalter mit Innenkühlung

toolholder with internal cooling

D min. 15 mm

D min. 15 mm



innere Kühlmittelzufuhr through coolant

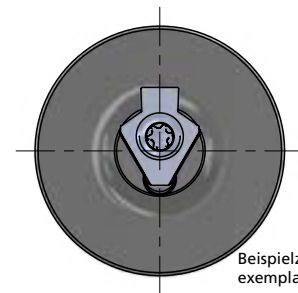
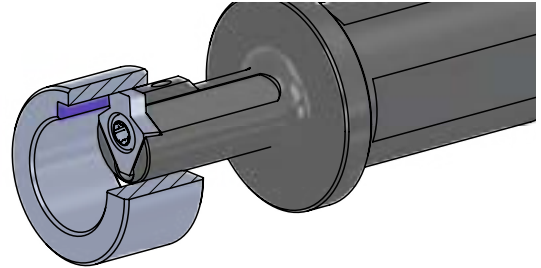
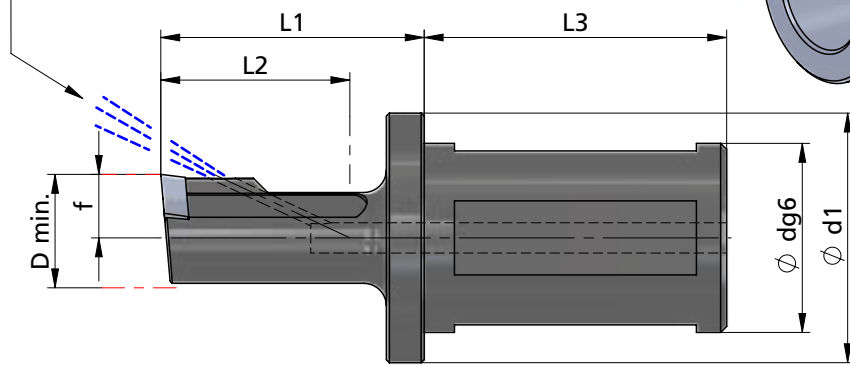

Beispielzeichnung
exemplary application

Abmessungen in mm

dimensions in mm



Bestellnummer part number	D min.	Ø d g6 x L3 Aufnahme clamping part	L1	L2	f	Ø d1	Spannschraube screw	Schraubenschlüssel wrench	Anzugs- drehmoment torque	für Schneidplatte for insert
NHV.15.IK25.1	15	Ø25 x 40	35	25	8.4	33	A.SPS027	TR15	4.0 Nm	NV15...
NHV.15.IK25.2	15	Ø25 x 40	50	40	8.4	33				
NHV.15.IK25.3	15	Ø25 x 40	70	60	8.4	33				
NHV.15.IK25.4	15	Ø25 x 40	85	75	8.4	33				



Bestellbeispiel:
NHV.15.IK25.1

order-example:
NHV.15.IK25.1

NUTSTOSEN

Herstellung von Längsnuten
und Innenprofilen

broaching keyways
and internal profiles

Typ NHV.15

Klemmhalter
für angetriebene Stosswerkzeuge

D min. 15 mm

toolholder
for driven slotting tool

D min. 15 mm

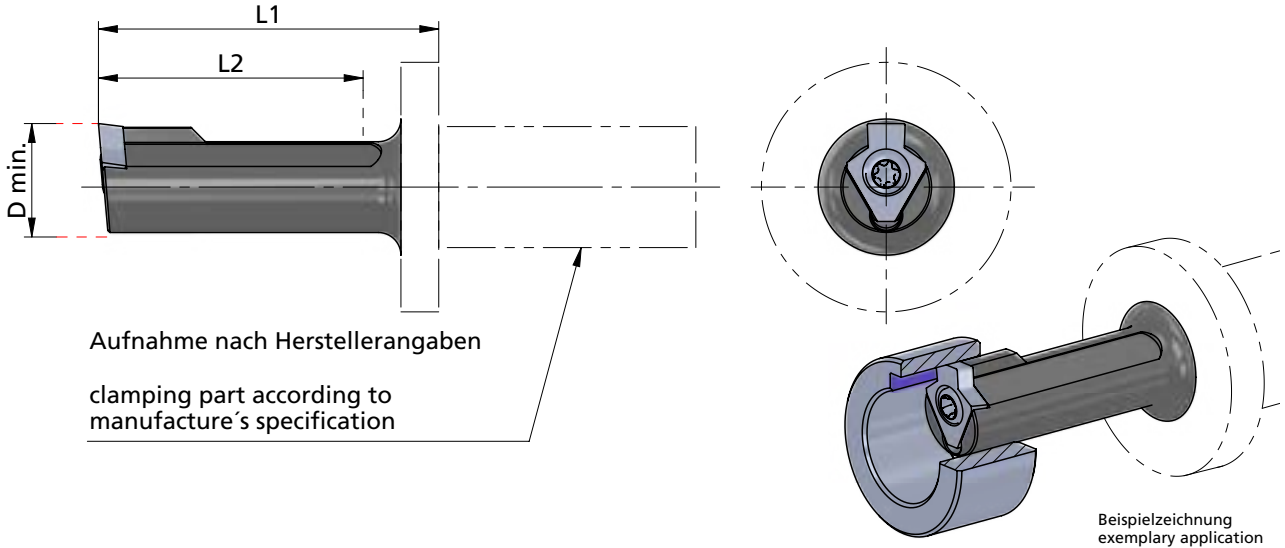

Abmessungen in mm

dimensions in mm



*

Bestellnummer part number	D min.	Aufnahme nach Herstellerangabe clamping part acc. to manufac. specification	L1	L2	für Nutstosseräte for broaching device	Spannschraube screw	Schraubenschlüssel wrench	Anzugs- drehmoment torque	für Schneidplatte for insert
NHV.15.0012.1	15	Ø12 x 25	40	36	Schwarzer 1				
NHV.15.0015.1	15	Ø15 x 33	45	36	Schwarzer 2 in 1				
NHV.15.0015.2	15	Ø15 x 30	58	42	Schwarzer 2 in 1				
NHV.15.0016.1	15	Ø16 x 30	46	36	EWS Slot + Benz LinA				
NHV.15.MP16.1	15	Ø16 x 34	45	35	Mario Pinto Stoßeinheit				
NHV.15.MP16.2	15	Ø16 x 34	75	65	Mario Pinto Stoßeinheit				
NHV.15.MT16.1	15	Ø16 x 25	50	40	MT Marchetti	A.SPS027	TR15	4 Nm	NV15...
NHV.15.WT16.1	15	Ø16 x 6	49	35	WTO Stoßeinheit				
NHV.15.WT16.2	15	Ø16 x 6	69	55	WTO Stoßeinheit				
NHV.15.0020.1.IK*	15	Ø20 x 39.5	46	36	EWS Slot P20 / incl. IKZ + Benz LinA 4.0 / incl. IKZ				
NHV.15.0020.2.IK*	15	Ø20 x 39.5	66	55	EWS Slot P20 / incl. IKZ + Benz LinA 4.0 / incl. IKZ				

NUTSTOSSEN

Herstellung von Längsnuten und Innenprofilen

broaching keyways and internal profiles

Typ NV15

Schneideinsatz
Nuttiefe bis 3.3
Toleranzklasse P9 / JS9 / D9 / C11 / inch

D min. 15 mm

insert
depth of groove up to 3.3
tolerance grade P9 / JS9 / D9 / C11 / inch

D min. 15 mm

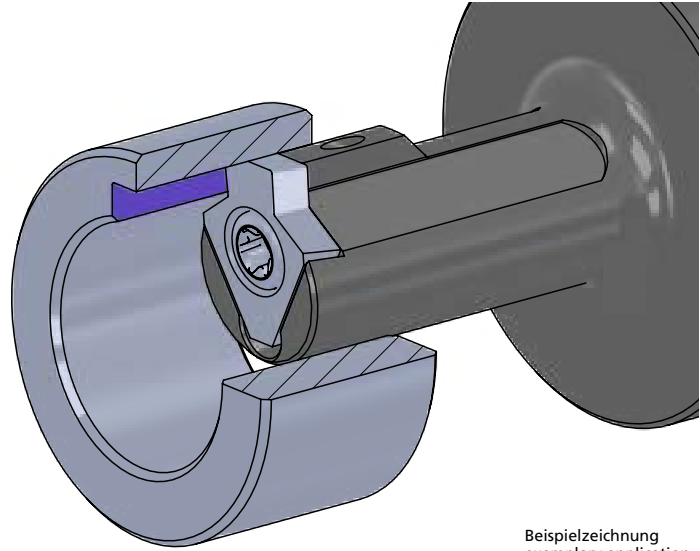
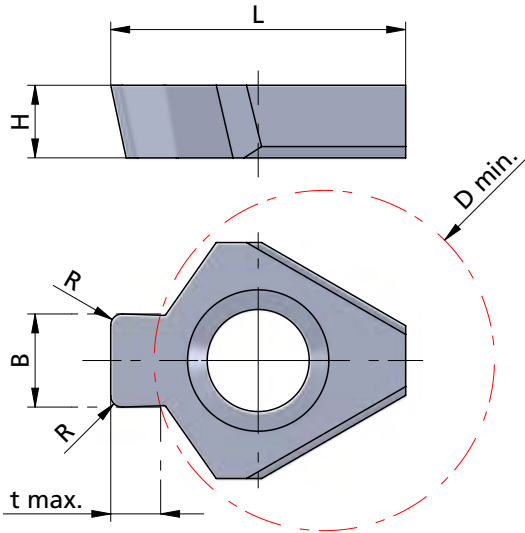

Beispielzeichnung
exemplary application

Abmessungen in mm

dimensions in mm

Bestellnummer part number	Nenngröße nominal size	Schneideinsatz nach DIN insert according DIN	D min.	B	B (inch)	R	L	t max.	H	K10F AL41F P18C	für Klemmhalter for toolholder type
NV15.0398.02	4	P9	15	3.98		0.2	13	2.3	3.2	●	NHV.15...
NV15.0498.02	5	DIN 6885 fester Sitz	15	4.98		0.2	13	2.8	3.2	●	
NV15.0598.02	6	strong fit	15	5.98		0.2	13	3.3	3.2	●	
NV15.0401.02	4	JS9	15	4.01		0.2	13	2.3	3.2	●	
NV15.0501.02	5	DIN 6885 leichter Sitz	15	5.01		0.2	13	2.8	3.2	●	
NV15.0601.02	6	slightly fit	15	6.01		0.2	13	3.3	3.2	●	
NV15.040D.02	4	D9	15	4.05		0.2	13	2.3	3.2	●	
NV15.050D.02	5	DIN 6885 GLEITSITZ	15	5.05		0.2	13	2.8	3.2	●	
NV15.060D.02	6	sliding fit	15	6.05		0.2	13	3.3	3.2	●	
NV15.0410.050	4	C11	15	4.10		0.50	13	2.2	3.2	●	
NV15.0510.050	5	DIN 138 Standard	15	5.10		0.50	13	2.5	3.2	●	
NV15.0612.085	6		15	6.12		0.85	13	2.6	3.2	●	
NV15.U0478.02	3/16"	inch	15	4.78	0.189"	0.2	13	2.8	3.2	●	

Weitere HM Sorten können Sie in der Sortenübersicht im Kapitel "Technische Hinweise" und der Preisliste finden.

Bestellbeispiel:
für Sorte AL41F:
NV15.0398.02/AL41F

More carbide grades you can find in the grades summary in the chapter "technical instructions" and in the price list.

order-example:
grade AL41F:
NV15.0398.02/AL41F



NUTSTOSSEN

Herstellung von Längsnuten
und Innenprofilen

broaching keyways
and internal profiles

Typ NHV.22 / NHV.30 / NHV.38 / NHV.45

Klemmhalter
mit Innenkühlung

D min. 22 / 30 / 38 / 45 mm

toolholder
with internal cooling

D min. 22 / 30 / 38 / 45 mm

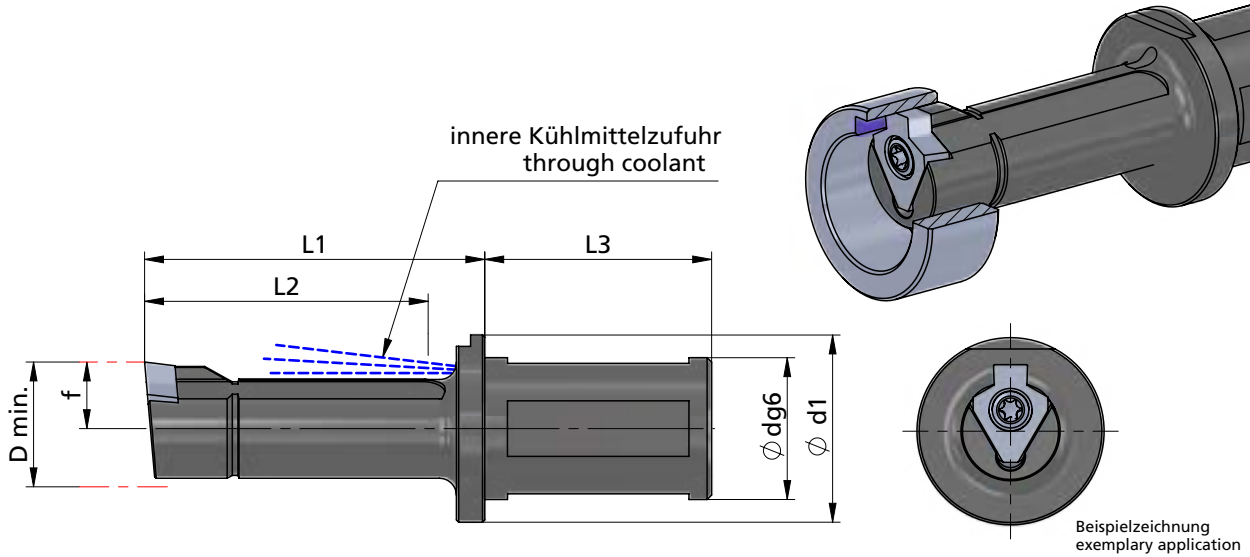

Beispielzeichnung
exemplary application

Abmessungen in mm

dimensions in mm



Bestellnummer part number	D min.	Ø d g6 x L3 Aufnahme clamping part	L1	L2	f	Ø d1	Spannschraube screw	Schraubenschlüssel wrench	Anzugs- drehmoment torque	für Schneidplatte for insert
NHV.22.0025.1	22	Ø25 x 40	60	50	12	33	A.SPS011	TR20-P	6.0 Nm	NPV...
NHV.22.0025.2	22	Ø25 x 40	85	75	12	33				
NHV.22.0025.3	22	Ø25 x 60	115	105	12	33				
NHV.30.0032.1	30	Ø32 x 40	60	50	16.5	45				
NHV.30.0032.2	30	Ø32 x 40	85	75	16.5	45				
NHV.30.0032.3	30	Ø32 x 40	115	105	16.5	45				
NHV.30.0032.4	30	Ø32 x 60	160	150	16.5	45				
NHV.38.0032.1	38	Ø32 x 40	60	50	22	45				
NHV.38.0032.2	38	Ø32 x 40	85	75	22	45				
NHV.38.0032.3	38	Ø32 x 40	115	105	22	45				
NHV.38.0032.4	38	Ø32 x 60	175	165	22	45				
NHV.45.0040.1	45	Ø40 x 60	60	50	24	55				
NHV.45.0040.3	45	Ø40 x 60	115	105	24	55				
NHV.45.0040.4	45	Ø40 x 60	165	155	24	55				
NHV.45.0040.5	45	Ø40 x 60	215	205	24	55				

NUTSTOSEN

Herstellung von Längsnuten und Innenprofilen

broaching keyways and internal profiles

Typ NHV.22 / NHV.30

Klemmhalter für angetriebene Stosswerkzeuge

D min. 22 / 30 mm

toolholder for driven slotting tool

D min. 22 / 30 mm

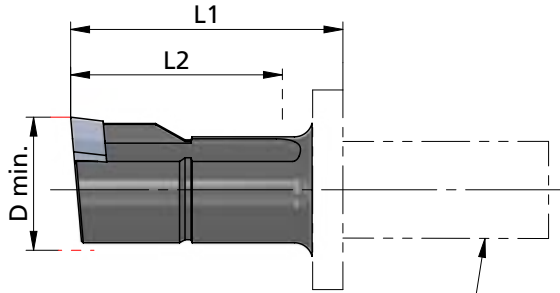

Aufnahme nach Herstellerangaben
clamping part according to manufacture's specification

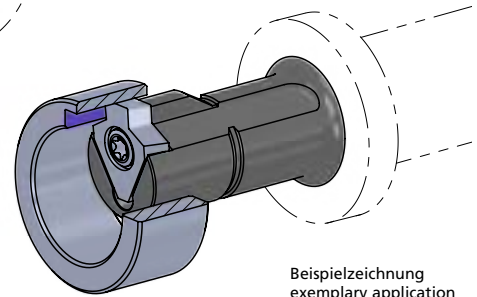
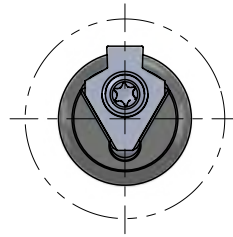

Beispielzeichnung
exemplary application

Abmessungen in mm

dimensions in mm



Bestellnummer part number	D min.	Aufnahme nach Herstellerangabe clamping part acc. to manufac. specification	L1	L2	für Nutstosseräte for broaching device	Spannschraube screw	Schraubenschlüssel wrench	Anzugs- drehmoment torque	für Schneidplatte for insert
NHV.22.0012.1	22	Ø12 x 25	40	36	Schwarzer 1				
NHV.22.0015.1	22	Ø15 x 33	37	36	Schwarzer 2 in 1				
NHV.22.0015.2	22	Ø15 x 30	50	42	Schwarzer 2 in 1				
NHV.22.0016.1	22	Ø16 x 30	45	36	EWS Slot + Benz LinA				
NHV.22.0016.2	22	Ø16 x 30	65	55	EWS Slot + Benz LinA				
NHV.22.MP16.1	22	Ø16 x 34	45	35	Mario Pinto Stoßeinheit				
NHV.22.MP16.2	22	Ø16 x 34	75	65	Mario Pinto Stoßeinheit				
NHV.22.MT16.1	22	Ø16 x 25	58	50	MT Marchetti	A.SPS011	TR20-P	6 Nm	NPV...
NHV.22.WT16.1	22	Ø16 x 6	49	35	WTO Stoßeinheit				
NHV.22.WT16.2	22	Ø16 x 6	69	55	WTO Stoßeinheit				
NHV.22.0020.1.IK*	22	Ø20 x 39.5	46	36	EWS Slot P20 / incl. IKZ + Benz LinA 4.0 / incl. IKZ				
NHV.22.0020.2.IK*	22	Ø20 x 39.5	66	55	EWS Slot P20 / incl. IKZ + Benz LinA 4.0 / incl. IKZ				
NHV.30.0012.1	30	Ø12 x 25	40	36	Schwarzer 1				

Bestellbeispiel:
NHV.22.0012.1

order-example:
NHV.22.0012.1



NUTSTOSEN

Herstellung von Längsnuten
und Innenprofilen

broaching keyways
and internal profiles

Typ NPV

Schneideinsatz
Nuttiefe bis 10 mm,
Toleranzklassen P9

insert
depth of groove up to 10 mm,
tolerance grade P9

B = 5 - 20 mm

B = 5 - 20 mm

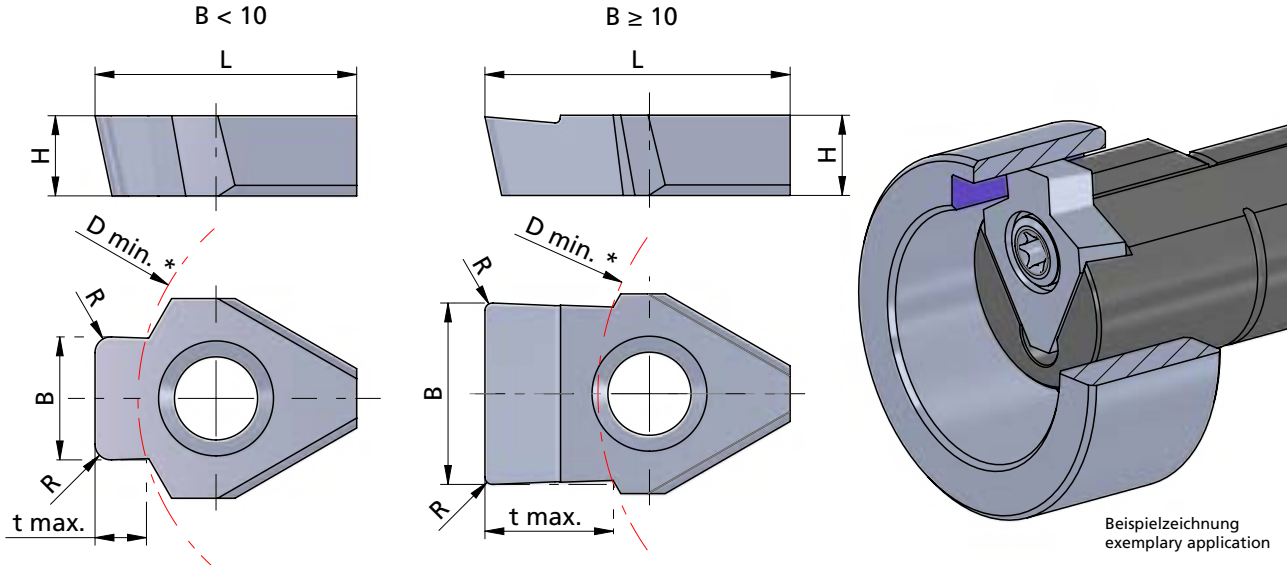

Abmessungen in mm

dimensions in mm

Bestellnummer part number	Nenngröße nominal size	Schneideinsatz nach DIN insert according DIN	B	R	L	t max.	H	für Klemhalter for toolholder type			
								K10F	AL41F	P18C	
NPV.0498.02	5		4.98	0.2	17.3	2.7	5.3	●			NHV.22....
NPV.0598.02	6		5.98	0.2	17.3	3.4	5.3	●			NHV.22....
NPV.0798.02	8		7.98	0.2	17.3	4.1	5.3	●			NHV.30. ... (NHV.22)
NPV.0998.03	10	P9	9.98	0.3	17.3	4.2	5.3	●			NHV.30. ... (NHV.22)
NPV.1197.03	12	DIN 6885 fester Sitz	11.98	0.3	20.1	5.7	5.3	●			NHV.38. ... (NHV.30/22. ...)
NPV.1397.03	14	strong fit	13.97	0.3	20.1	7.5	6.3	●			NHV.45. ... (NHV.38/30/22. ...)
NPV.1597.03	16		15.97	0.3	20.1	7.5	6.3	●			NHV.45. ... (NHV.38/30/22. ...)
NPV.1797.05	18		17.97	0.4	20.1	9.5	6.3	●			NHV.45. ... (NHV.38/30/22. ...)
NPV.1997.05	20		19.97	0.5	20.1	10	6.3	●			NHV.45. ... (NHV.38/30/22. ...)

Klemhalter in Klammer sind nicht optimal in der Unterstützung. Schnittwerte reduzieren! Weitere HM Sorten können Sie in der Sortenübersicht im Kapitel "Technische Hinweise" und der Preisliste finden.

Bestellbeispiel:
für Sorte AL41F:
NPV.0498.02/AL41F

*
Klemhalter bestimmt den D min.
toolholder determines the D min.

Please note that toolholders in brackets are not the optimal choice. If using them, please reduce the cutting data!
More carbide grades you can find in the grades summary in the chapter "technical instructions" and in the price list.
order-example:
grade AL41F:
NPV.0498.02/AL41F

NUTSTOSEN

Herstellung von Längsnuten und Innenprofilen

broaching keyways and internal profiles

Typ NPV

Schneideinsatz
Nuttiefe bis 10 mm,
Toleranzklassen JS9

B = 5 - 20 mm

insert
depth of groove up to 10 mm,
tolerance grade JS9

B = 5 - 20 mm

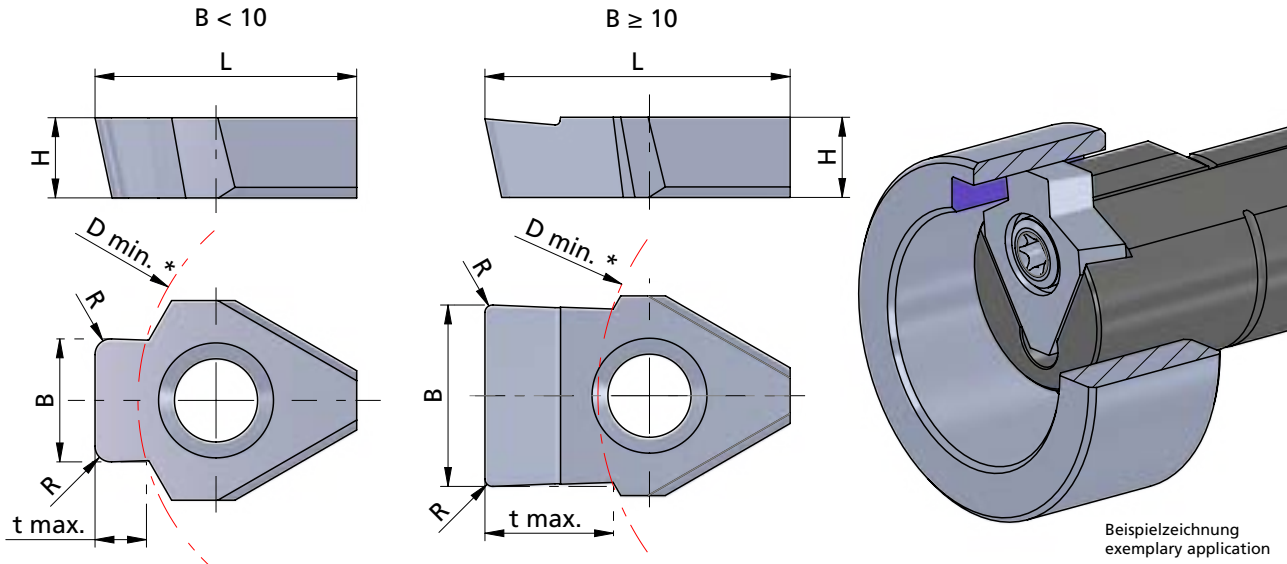

Abmessungen in mm

dimensions in mm

Bestellnummer part number	Nenngröße nominal size	Schneideinsatz nach DIN insert according DIN	B	R	L	t max.	H	für Klemmhalter for toolholder type			
								K10F	AL41F	P18C	
NPV.0501.02	5		5.01	0.2	17.3	2.7	5.3	●			NHV.22....
NPV.0601.02	6		6.01	0.2	17.3	3.4	5.3	●			NHV.22....
NPV.0801.02	8		8.01	0.2	17.3	4.1	5.3	●			NHV.30. ... (NHV.22)
NPV.1001.03	10		10.01	0.3	17.3	4.2	5.3	●			NHV.30. ... (NHV.22)
NPV.1202.03	12	JS9 DIN 6885	12.02	0.3	20.1	5.7	5.3	●			NHV.38. ... (NHV.30/22. ...)
NPV.1202.05	-	leichter Sitz slightly fit	12.02	0.5	20.1	8.5	5.3	●			NHV.38. ... (NHV.30/22. ...)
NPV.1402.03	14		14.02	0.3	20.1	7.5	6.3	●			NHV.45. ... (NHV.38/30/22. ...)
NPV.1602.03	16		16.02	0.3	20.1	7.5	6.3	●			NHV.45. ... (NHV.38/30/22. ...)
NPV.1802.05	18		18.02	0.4	20.1	9.5	6.3	●			NHV.45. ... (NHV.38/30/22. ...)
NPV.2002.05	20		20.02	0.5	20.1	10	6.3	●			NHV.45. ... (NHV.38/30/22. ...)

Klemmhalter in Klammer sind nicht optimal in der Unterstützung. Schnittwerte reduzieren! Weitere HM Sorten können Sie in der Sortenübersicht im Kapitel "Technische Hinweise" und der Preisliste finden.

Bestellbeispiel:
für Sorte AL41F:
NPV.0501.02/AL41F

*
Klemmhalter bestimmt den D min.
toolholder determines the D min.

Please note that toolholders in brackets are not the optimal choice. If using them, please reduce the cutting data!
More carbide grades you can find in the grades summary in the chapter "technical instructions" and in the price list.
order-example:
grade AL41F:
NPV.0501.02/AL41F

NUTSTOSEN

Herstellung von Längsnuten
und Innenprofilen

broaching keyways
and internal profiles

Typ NPV

Schneideinsatz
Nuttiefe bis 10 mm,
Toleranzklassen H9 / D9

B = 5 - 20 mm

insert
depth of groove up to 10 mm,
tolerance grade H9 / D9

B = 5 - 20 mm

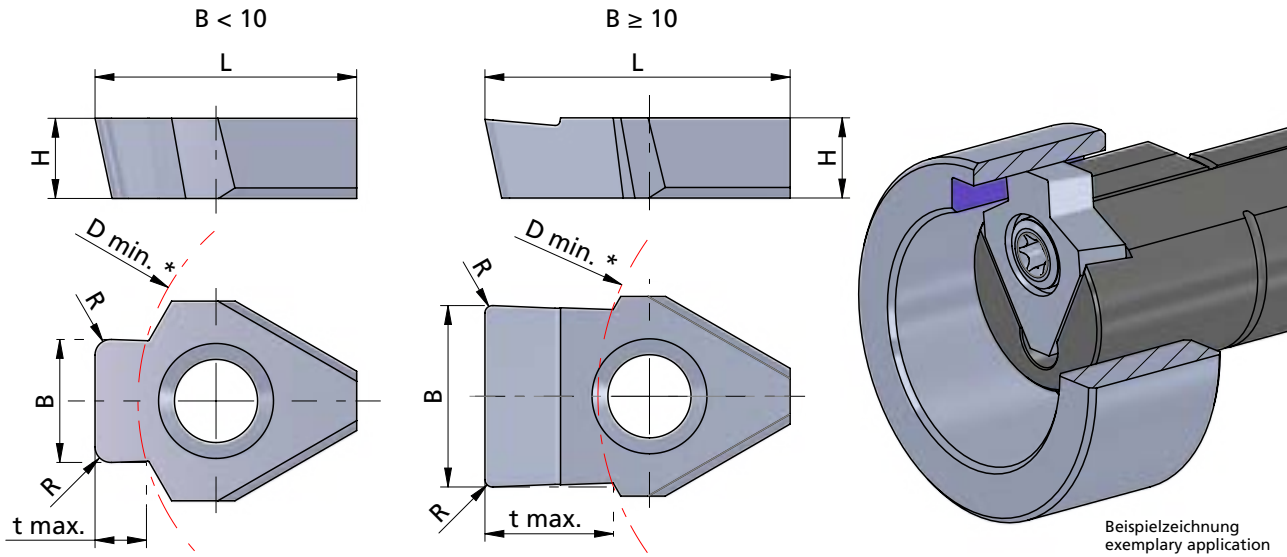

Abmessungen in mm

dimensions in mm

Bestellnummer part number	Nenngröße nominal size	Schneideinsatz nach DIN insert according DIN	B	R	L	t max.	H	K10F	AL41F	P18C	für Klemhalter for toolholder type
NPV.050H.02	5	H9 DIN 6885	5.02	0.2	17.3	2.7	5.3	●			NHV.22....
NPV.060H.02	6		6.02	0.2	17.3	3.4	5.3	●			NHV.22....
NPV.080H.02	8		8.02	0.2	17.3	4.1	5.3	●			NHV.30. ... (NHV.22)
NPV.100H.03	10		10.02	0.3	17.3	4.2	5.3	●			NHV.30. ... (NHV.22)
NPV.120H.03	12		12.03	0.3	20.1	5.7	5.3	●			NHV.38. ... (NHV.30/22. ...)
NPV.050D.02	5	D9 DIN 6885 Gleitsitz sliding fit	5.05	0.2	17.3	2.7	5.3	●			NHV.22. ...
NPV.060D.02	6		6.05	0.2	17.3	3.4	5.3	●			NHV.22. ...
NPV.080D.02	8		8.06	0.2	17.3	4.1	5.3	●			NHV.30. ... (NHV.22)
NPV.100D.03	10		10.06	0.3	17.3	4.2	5.3	●			NHV.30. ... (NHV.22)
NPV.120D.03	12		12.08	0.3	20.1	5.7	5.3	●			NHV.38. ... (NHV.30/22. ...)
NPV.140D.03	14		14.08	0.3	20.1	7.5	6.3	●			NHV.45. ... (NHV.38/30/22. ...)
NPV.160D.03	16		16.08	0.3	20.1	7.5	6.3	●			NHV.45. ... (NHV.38/30/22. ...)
NPV.180D.05	18		18.08	0.5	20.1	9.5	6.3	●			NHV.45. ... (NHV.38/30/22. ...)
NPV.200D.05	20		20.1	0.5	20.1	10	6.3	●			NHV.45. ... (NHV.38/30/22. ...)

Klemhalter in Klammer sind nicht optimal in der Unterstützung. Schnittwerte reduzieren! Weitere HM Sorten können Sie in der Sortenübersicht im Kapitel "Technische Hinweise" und der Preisliste finden.

* Klemhalter bestimmt den D min. toolholder determines the D min.

Please note that toolholders in brackets are not the optimal choice. If using them, please reduce the cutting data!
More carbide grades you can find in the grades summary in the chapter "technical instructions" and in the price list.
order-example:
grade AL41F:
NPV.050H.02/AL41F

Bestellbeispiel:
für Sorte AL41F:
NPV.050H.02/AL41F

NUTSTOSEN

Herstellung von Längsnuten und Innenprofilen

broaching keyways and internal profiles

Typ NPV

Schneideinsatz
Nuttiefe bis 8.5 mm,
Toleranzklassen C11 / inch

B = 6 - 12 mm

insert
depth of groove up to 8.5 mm,
tolerance grade C11 / inch

B = 6 - 12 mm

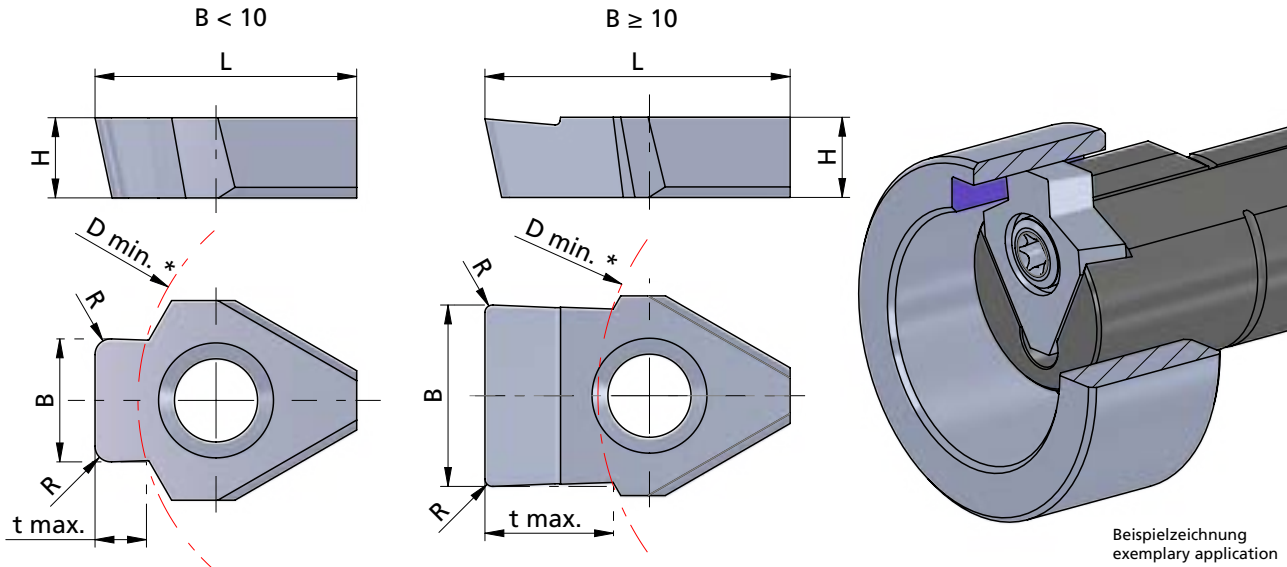

Abmessungen in mm

dimensions in mm

Bestellnummer part number	Nenngröße nominal size	Schneideinsatz nach DIN insert according DIN	B	B (inch)		R	L	t max.	H	K10F	AL41F	P18C	für Klemhalter for toolholder type
				B	R								
NPV.0612.085	6	C11 DIN 138 Standard	6.12		0.85	17.3	2.6	5.3		●			NHV.22...
NPV.0713.085	7		7.13		0.85	17.3	3.3	5.3		●			NHV.22...
NPV.0813.105	8		8.13		1.05	17.3	3.4	5.3		●			NHV.30... (NHV.22)
NPV.1013.105	10		10.13		1.05	20.1	4.2	5.3		●			NHV.38..(NHV.30/22..)
NPV.1215.135	12		12.15		1.35	20.1	5.1	5.3		●			NHV.38..(NHV.30/22..)
NPV.1215.175	12		12.15		1.75	20.1	6.6	5.3		●			NHV.38..(NHV.30/22..)
NPV.1215.225	12		12.15		2.25	20.1	8.5	5.3		●			NHV.38..(NHV.30/22..)
NPV.U0638.02	1/4"	inch	6.38	0.251"	0.2	17.3	3.4	5.3		●			NHV.22...
NPV.U0797.02	5/16"		7.97	0.314"	0.2	17.3	4.1	5.3		●			NHV.22...
NPV.U0956.03	3/8"		9.56	0.377"	0.3	17.3	5.0	5.3		●			NHV.30... (NHV.22)
NPV.U1273.03	1/2"		12.73	0.502"	0.3	20.1	6.6	5.3		●			NHV.38..(NHV.30/22..)



Klemhalter in Klammer sind nicht optimal in der Unterstützung. Schnittwerte reduzieren! Weitere HM Sorten können Sie in der Sortenübersicht im Kapitel "Technische Hinweise" und der Preisliste finden.

Bestellbeispiel:
für Sorte AL41F:
NPV.0612.085/AL41F

*
Klemhalter bestimmt den D min.
toolholder determines the D min.

Please note that toolholders in brackets are not the optimal choice. If using them, please reduce the cutting data!
More carbide grades you can find in the grades summary in the chapter "technical instructions" and in the price list.
order-example:
grade AL41F:
NPV.0612.085/AL41F

NUTSTOSSEN

Herstellung von Längsnuten
und Innenprofilen

broaching keyways
and internal profiles

NV15. ...45.1 / Typ NPV. ...45.1

Schneideinsatz
Fasen 45°

D min. 15 mm
D min. 22 / 38 mm

insert
chamfering 45°

D min. 15 mm
D min. 22 / 38 mm

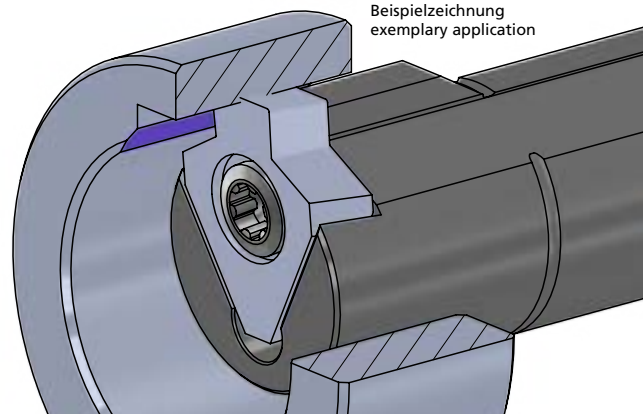
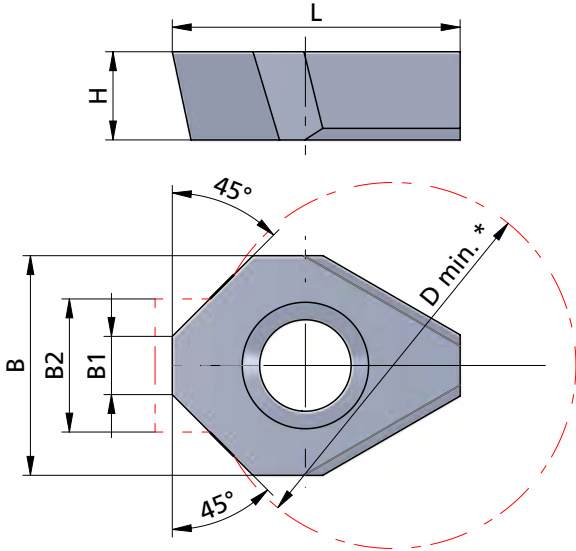

Abmessungen in mm

dimensions in mm

Bestellnummer part number	D min.	B	B1	B2 Nutenbreite width of groove	H	L	für Klemmhalter for toolholder type			
							K10F	AL41F	P18C	
NV15.4545.1	15	10.4	2.5	5 - 8	3.2	13	●			NHV.15....
NPV.3045.1	22	13.2	3.5	6 - 10	5.3	17.3	●			NHV.22....
NPV.6045.1	38	13.2	6.0	10 - 12	5.3	20.2	●			NHV.38....(NHV.30/22. ...)

Klemmhalter in Klammer sind nicht optimal in der Unterstützung. Schnittwerte reduzieren!
Weitere HM Sorten können Sie in der Sortenübersicht im Kapitel "Technische Hinweise" und der Preisliste finden.

Bestellbeispiel:
für Sorte AL41F:
NPV.3045.1/AL41F

*
Klemmhalter bestimmt den D min.
toolholder determines the D min.

Please note that toolholders in brackets are not the optimal choice. If using them, please reduce the cutting data!
More carbide grades you can find in the grades summary in the chapter "technical instructions" and in the price list.
order-example:
grade AL41F:
NPV.3045.1/AL41F

NUTSTOSEN

Herstellung von Längsnuten und Innenprofilen

broaching keyways and internal profiles

Typ NPU.SW

Schneideinsatz für Innensechskant

insert for hexagon socket

Schlüsselweite ab SW 2.5 - 8 mm

wrench size from 2.5 - 8 mm

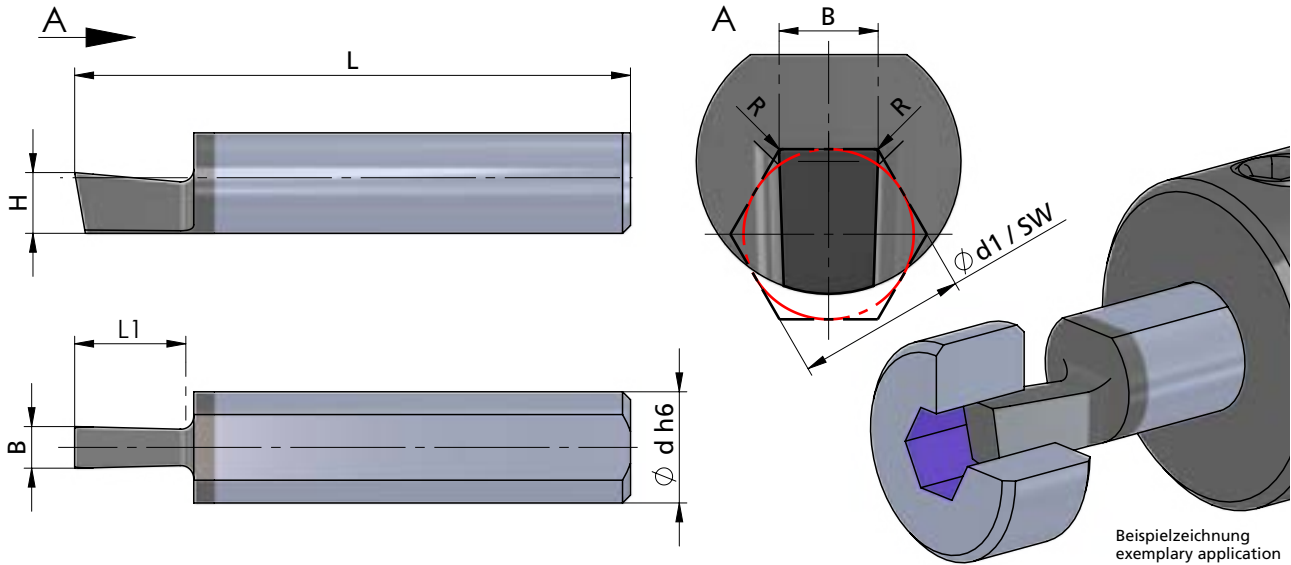

Nutmaß nach DIN

width of the groove according to DIN

Abmessungen in mm

dimensions in mm

Bestellnummer part number	Schlüsselweite SW wrench size	Ø d1 Bohrung Ø d1 hole	B	H +0.05	R	L	L1	Ø d h6	K10F AL41F P18C	für Klemhalter for toolholder type
NPU.SW25.25.01	2.5	2.5	1.48	2.0	0.05	30	4.5	7	●	NHU...
NPU.SW30.30.01	3.0	3.0	1.77	2.5	0.05	30	5.0	7	●	
NPU.SW35.35.01	3.5	3.5	2.07	2.9	0.05	30	6.0	7	●	
NPU.SW40.40.01	4.0	4.0	2.35	3.3	0.05	35	6.5	7	●	
NPU.SW45.45.01	4.5	4.5	2.64	3.8	0.1	35	7.5	7	●	
NPU.SW50.50.01	5.0	5.0	2.95	4.2	0.1	35	9.5	7	●	
NPU.SW60.60.01	6.0	6.0	3.53	5.2	0.1	35	9.5	7	●	
NPU.SW80.80.01	8.0	8.0	4.70	5.7	0.1	37	12.5	7	●	

Weitere HM Sorten können Sie in der Sortenübersicht im Kapitel "Technische Hinweise" und der Preisliste finden.

Bestellbeispiel:
für Sorte AL41F:
NPU.SW25.25.01/AL41F

More carbide grades you can find in the grades summary in the chapter "technical instructions" and in the price list.

order-example:
grade AL41F:
NPU.SW25.25.01/AL41F



NUTSTOSEN

Herstellung von Längsnuten und Innenprofilen

broaching keyways and internal profiles

Typ NPU.SW

Schneideinsatz 120° für Innensechskant

insert 120° for hexagon socket

Schlüsselweite ab SW 1.0 - 8.0 mm

wrench size from 1.0 - 8.0 mm

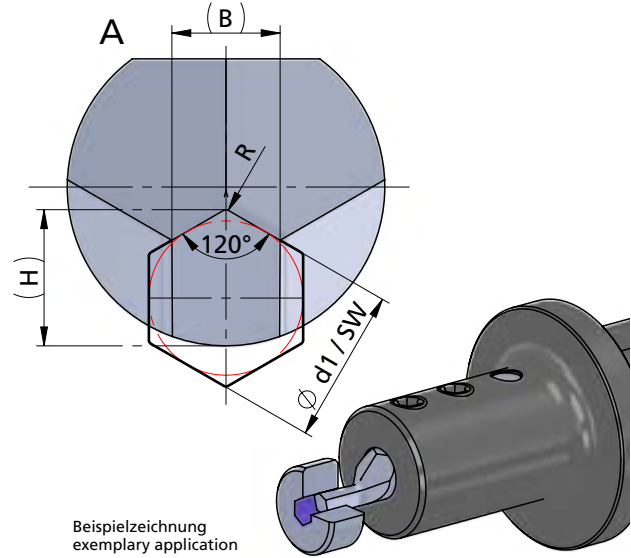
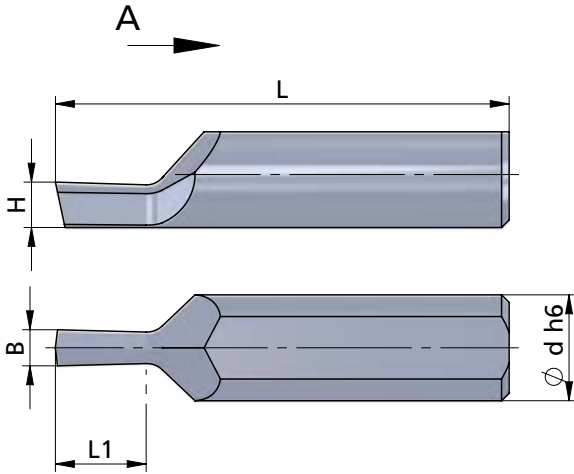

Beispielzeichnung
exemplary application

Nutmaß nach DIN

width of the groove according to DIN

Abmessungen in mm

dimensions in mm

Bestellnummer part number	Sechskant SW hexagon socket SW	Ø d1 Bohrung Ø d1 hole	B	H	R	L	L1	Ø d h6	Material			für Klemhalter for toolholder type
									K10F	AL41F	P18C	
NPU.SW10.13	SW 1.0 - 1.3	1.0 - 1.3	0.7	0.8	0.05	30	2.0	7	●			NHU, ...
NPU.SW14.19	SW 1.4 - 1.9	1.4 - 1.9	1.0	1.2	0.05	30	2.5	7	●			
NPU.SW19.24	SW 1.9 - 2.4	1.9 - 2.4	1.4	1.6	0.05	30	3.5	7	●			
NPU.SW24.29	SW 2.4 - 2.9	2.4 - 2.9	1.6	2.1	0.1	30	4.0	7	●			
NPU.SW29.34	SW 2.9 - 3.4	2.9 - 3.4	2.0	2.6	0.1	30	5.0	7	●			
NPU.SW34.42	SW 3.4 - 4.2	3.4 - 4.2	2.4	3.0	0.1	30	6.0	7	●			
NPU.SW39.49	SW 3.9 - 4.9	3.9 - 4.9	2.8	3.5	0.1	35	7.5	7	●			
NPU.SW49.65	SW 4.9 - 6.5	4.9 - 6.5	3.5	4.5	0.1	35	9.0	7	●			
NPU.SW59.80	SW 5.9 - 8.0	5.9 - 8.0	4.2	5.5	0.1	35	10.0	7	●			

Weitere HM Sorten können Sie in der Sortenübersicht im Kapitel "Technische Hinweise" und der Preisliste finden.

More carbide grades you can find in the grades summary in the chapter "technical instructions" and in the price list.

NUTSTOSSEN

Herstellung von Längsnuten und Innenprofilen

broaching keyways and internal profiles

Typ NP10.SW

Schneideinsatz für Innensechskant

insert for hexagon socket

Schlüsselweite ab SW 10 - 16 mm

wrench size from 10 - 16 mm

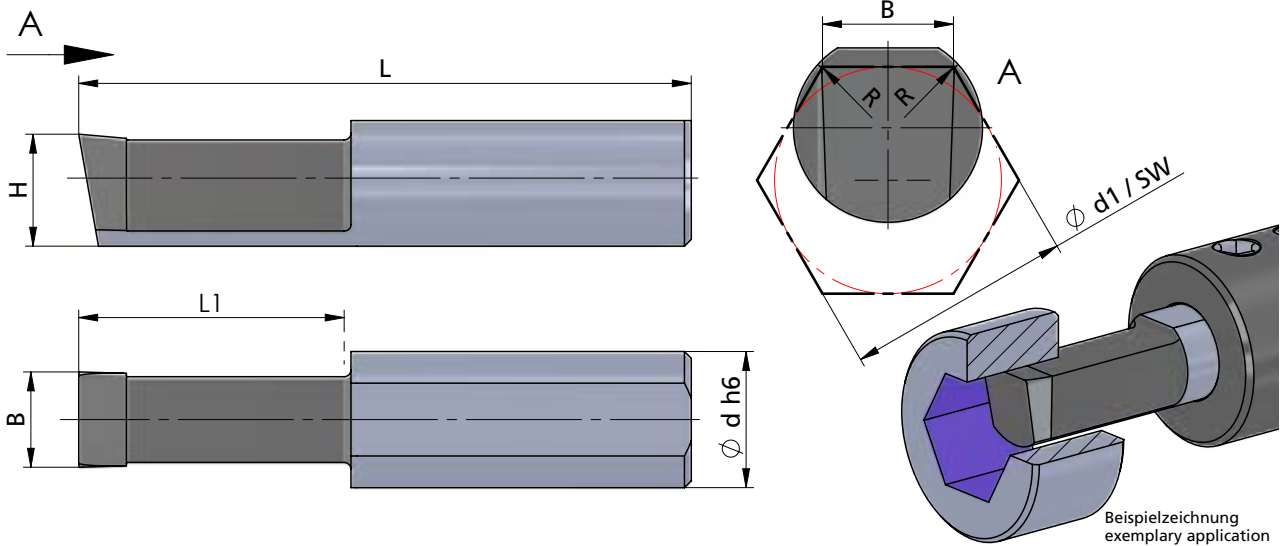

Nutmaß nach DIN

width of the groove according to DIN

Abmessungen in mm

dimensions in mm

Bestellnummer part number	Schlüsselweite SW wrench size	Ø d1 Bohrung Ø d1 hole	B	H +0.05	R	L	L1	Ø d h6	für Klemhalter for toolholder type			
									K10F	AL41F	P18C	
NP10.SW10.10.02	10	10	5.85	9.0	0.2	40	15	10	●	●	●	NH10...
NP10.SW12.12.03	12	12	7.02	8.2	0.3	45	20	10	●	●	●	
NP10.SW14.14.03	14	14	8.18	7.5	0.3	45	20	10	●	●	●	
NP10.SW16.16.04	16	16	9.34	6.2	0.4	50	25	10	●	●	●	

Weitere HM Sorten können Sie in der Sortenübersicht im Kapitel "Technische Hinweise" und der Preisliste finden.

Bestellbeispiel:
für Sorte AL41F:
NPU.SW10.10.02/AL41F

More carbide grades you can find in the grades summary in the chapter "technical instructions" and in the price list.

order-example:
grade AL41F:
NPU.SW10.10.02/AL41F



NUTSTOSEN

Herstellung von Längsnuten
und Innenprofilen

broaching keyways
and internal profiles

Typ NHV...SW25 / Typ NHV...90

Klemhalter
für Sechskant und Vierkant
mit Innenkühlung

D min. 13 / 14 / 20 mm

toolholder
for hexagon socket and square bore
with internal cooling

D min. 13 / 14 / 20 mm

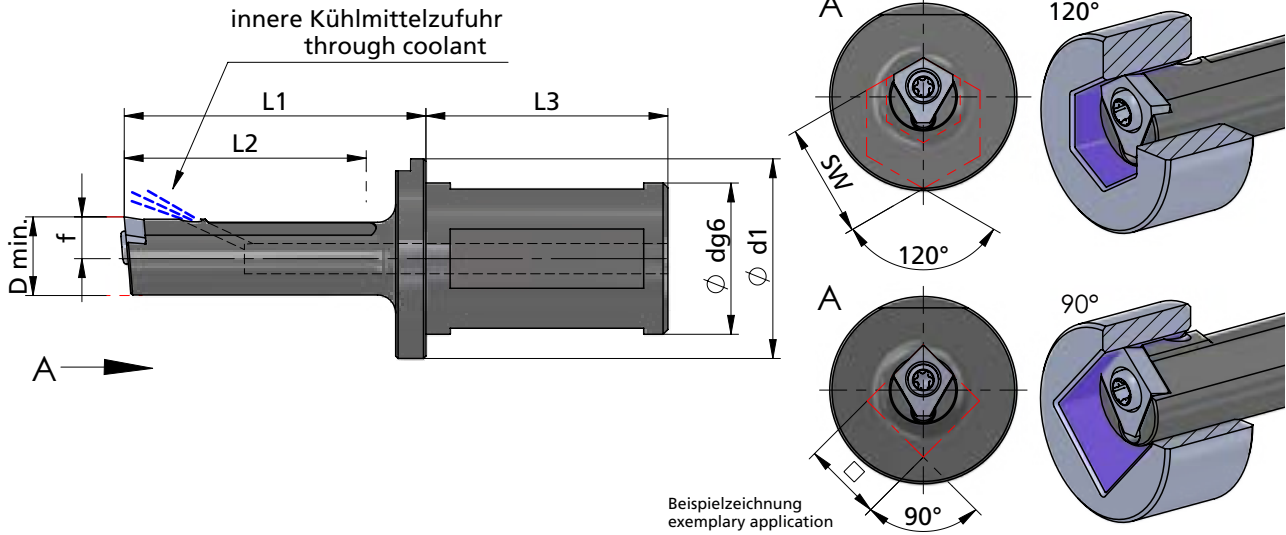

Abmessungen in mm

dimensions in mm



Bestellnummer part number	D min.	Ø d g6 x L3 Aufnahme clamping part	L1	L2	Ø d1	f	Spannschraube screw	Schraubenschlüssel wrench	Anzugs- drehmoment torque	für Schneidplatte for insert	Sechskant hexagon socket	Vierkant square bore
NHV.15.SW25.2	13	Ø25 x 40	50	40	33	6.9	A.SPS027	TR15	4.0 Nm	NV15.SW13.20	●	
NHV.22.SW25.1	20	Ø25 x 40	60	50	33	10	A.SPS011	TR20-P	6.0 Nm	NPV.SW20.32	●	
NHV.15.90.25.2	14	Ø25 x 40	50	40	33	7.9	A.SPS027	TR15	4.0 Nm	NV15.90.14.02		●
NHV.22.90.25.1	20	Ø25 x 40	60	50	33	11	A.SPS011	TR20-P	6.0 Nm	NPV.90.20.03		●



NUTSTOSSEN

Herstellung von Längsnuten und Innenprofilen

broaching keyways and internal profiles

Typ NV15.SW13 / NPV.SW20 / NV15.90 / NPV.90

Schneideinsatz für Sechskant und Vierkant

D min. 13 / 14 / 20 mm

insert for hexagon socket and square bore

D min. 13 / 14 / 20 mm

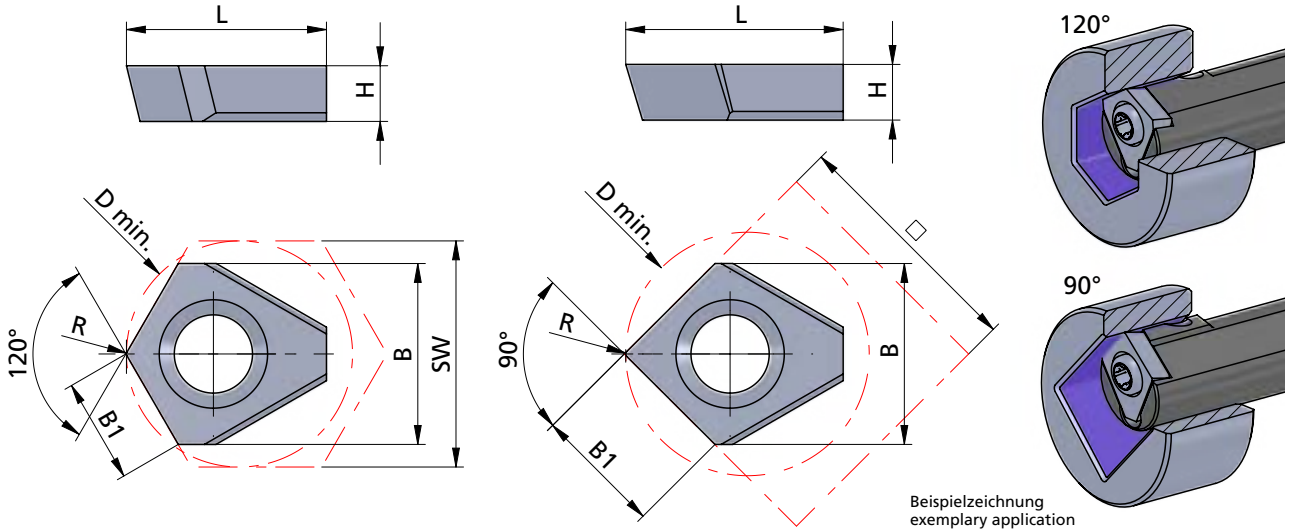

Beispielzeichnung
exemplary application

Abmessungen in mm

dimensions in mm

Bestellnummer part number	D min.	Sechskant SW hexagon socket SW	Vierkant □ square bore □	B	B1	R	L	H	Material			für Klemhalter for toolholder type
									K10F	AL41F	P18C	
NV15.SW13.20	13	SW 13-20		10.4	6.0	0.2	11.5	3.2	●			NHV.15.SW25.2
NPV.SW20.32	20	SW 20-32		16.3	9.4	0.3	16.8	6.3	●			NHV.22.SW25.1
NV15.90.14.02	14		□ 14	10.4	7.3	0.2	12.5	3.2	●			NHV.15.90.25.2
NPV.90.20.03	20		□ 20	14.6	10.3	0.3	17.8	6.3	●			NHV.22.90.25.1



Weitere HM Sorten können Sie in der Sortenübersicht im Kapitel "Technische Hinweise" und der Preisliste finden.

Bestellbeispiel:
für Sorte AL41F:
NV15.SW13.20/AL41F

More carbide grades you can find in the grades summary in the chapter "technical instructions" and in the price list.

order-example:
grade AL41F:
NV15.SW13.20/AL41F

NUTSTOSEN

Herstellung von Längsnuten
und Innenprofilen

broaching keyways
and internal profiles

Typ NHV...VZ...

Klemmhalter
für Verzahnungen,
mit Innenkühlung

toolholder
for gears,
with internal cooling

D min. 10 / 15 / 22 / 30 mm

D min. 10 / 15 / 22 / 30 mm

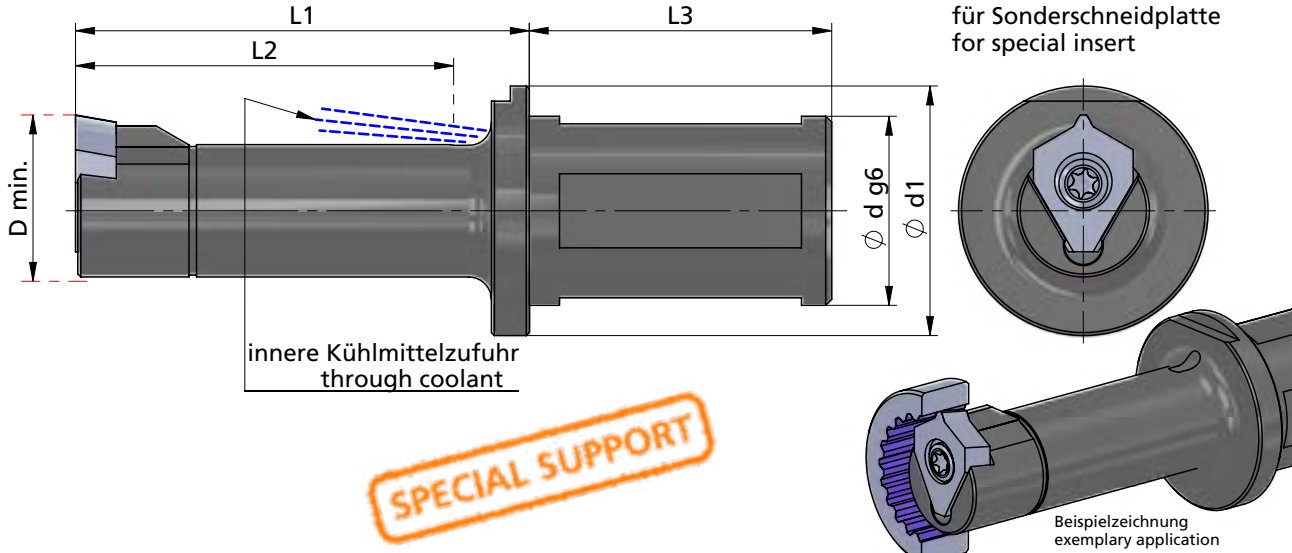

Abmessungen in mm

dimensions in mm



Bestellnummer part number	D min.	Ø d g6 x L3 Aufnahme clamping part	L1	L2	Ø d1	Spannschraube screw	Schraubenschlüssel wrench	Anzugs- drehmoment torque	für Sonderplatte for special insert
NHV.10.IK25.VZ51.1	10	Ø25 x 40	30	22	33	A.SPS018	T6F	0.6 Nm	NV10. ...
NHV.15.IK25.VZ52.2	15	Ø25 x 40	50	40	33	A.SPS027	TR15	4.0 Nm	NV15. ...
NHV.22.0025.VZ53.1	22	Ø25 x 40	60	50	33	A.SPS011	TR20-P	6.0 Nm	NPV. ...
NHV.30.0032.VZ53.2	30	Ø32 x 40	85	75	45	A.SPS011	TR20-P	6.0 Nm	NPV. ...

- Für Verzahnungen der gängigen Normen aus DIN, ISO, ANSI und GOST können wir Ihnen Schneidplatten als Profilwerkzeug im Sonder anbieten.

Fragen Sie nach einem Angebot unter:
angebote@duemmel.de

- We can offer you inserts as a special profile tool for gearing of the current standards from DIN, ISO, ANSI and GOST.

Ask for an offer at:
angebote@duemmel.de

NUTSTOSEN

Herstellung von Längsnuten
und Innenprofilen

broaching keyways
and internal profiles

Sets

SET - NPU

Toleranzklasse JS9
tolerance grade JS9

SET - NP10

Toleranzklasse JS9
tolerance grade JS9

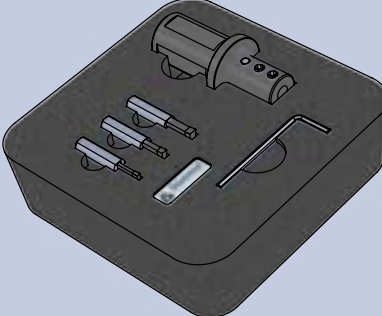
Bestellnummer part number	Inhalt content	K10F AL41F P18C
 <p>SET - NPU</p> <ul style="list-style-type: none"> • Toleranzklasse JS9 D min. 6 B = 2 / 3 / 4 • tolerance grade JS9 D min. 6 B = 2 / 3 / 4 	<p>Halter / toolholder: 1 x NHU.0025.1</p>	
	<p>Schneideinsatz / insert: 1 x NPU.0200.01.1 1 x NPU.0300.01.1 1 x NPU.0400.01.1</p>	<ul style="list-style-type: none"> • • •

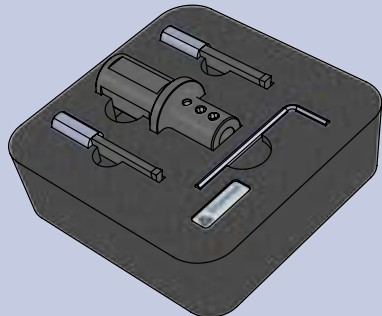
Bestellnummer part number	Inhalt content	K10F AL41F P18C
 <p>SET - NP10</p> <ul style="list-style-type: none"> • Toleranzklasse JS9 D min. 10 B = 4 / 5 • tolerance grade JS9 D min. 10 B = 4 / 5 	<p>Halter / toolholder: 1 x NH10.0025.1</p>	
	<p>Schneideinsatz / insert: 1 x NP10.400.02.3 1 x NP10.500.02.3</p>	<ul style="list-style-type: none"> • •



NUTSTOSSEN

Herstellung von Längsnuten
und Innenprofilen

broaching keyways
and internal profiles

Sets

SET - NPV

Toleranzklasse JS9
tolerance grade JS9

		Bestellnummer part number	Inhalt content	K10F AL41F P18C
		<p>SET - NPV</p> <ul style="list-style-type: none"> • Toleranzklasse JS9 D min. 22 / 30 B = 5.01 / 6.01 / 8.01 • tolerance grade JS9 D min. 22 / 30 B = 5.01 / 6.01 / 8.01 	<p>Halter / toolholder: 1 x NHV.22.0025.1</p> <p>Schneideinsatz / insert: 1 x NPV.0501.02 1 x NPV.0601.02 1 x NPV.0801.02</p>	<p>● ● ●</p>
				
<p>06- 34</p>	<p>Bestellbeispiel: SET-NPV</p>		<p>order-example: SET-NPV</p>	

NUTSTOSSEN

Herstellung von Längsnuten
und Innenprofilen

broaching keyways
and internal profiles

Technische Hinweise

Grundsätzliche Informationen zum Nutstossen

Technical instructions,
Basic informations about broaching keyways

Grundsätzliche Informationen zum Nutstossen

- Achten Sie auf den Freistich am Ende der geräumten Nut, damit das Werkzeug frei auslaufen kann.
- Während das Werkzeug zurückfährt, sollte die Schneide den Nutengrund nicht berühren.
- Das ausjustieren des Werkzeuges ist unerlässlich. Überprüfen sie deshalb den Durchmesser des Werkstückes genau, bevor Sie den ersten Einsatz fahren.
- Wenn Sie Öl oder eine Emulsion verwenden, werden die Späne vom Werkstück weggespült und Sie erzielen gleichzeitig eine perfekte Oberfläche.
- Wenn Sie das Werkzeug nach oben hin ausrichten, fallen die Späne automatisch nach unten, von der Schneide weg.
- Vermeiden Sie einen unterbrochenen Schnitt

Basic informations about broaching keyways

- an undercut is necessary at the end of the broached groove for tool run out.
- the insert should not touch the bottom of the groove as the tool retracts.
- setting of the tool is very important. Check accurate the component diameter before taking the first pass.
- using oil or emulsion helps to achieve better surface finish and flush chips out of the component.
- the tool should be set at the 12 o'clock position to ensure that chips fall away from the groove.
- avoid interrupted cutting.

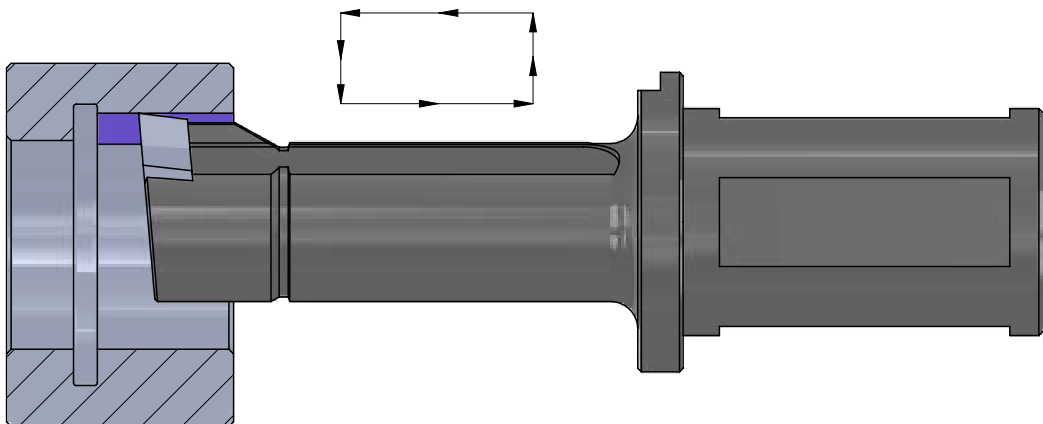

NUTSTOSSEN

Herstellung von Längsnuten
und Innenprofilen

broaching keyways
and internal profiles

Technische Hinweise

Hartmetallsorten und Beschichtungen

Technical instructions,
carbide grades and coatings

K10F

Universell einsetzbares Feinkornhartmetall mit guter Verschleißfestigkeit. Unbeschichtet geeignet für Anwendungen mit niedrigen und mittleren Schnittgeschwindigkeiten, sowie die Bearbeitung von NE-Metallen.

All purpose micrograin carbide with good abrasion resistance. Uncoated for applications with low or medium cutting speeds and machining of non-ferrous materials.

P04C

Optimierte, sehr universell einsetzbare TIALN-Beschichtung mit hoher Temperaturbeständigkeit bei hoher Härte. Sehr gut geeignet auch für NE-Metalle.

Optimized TIALN coating - very universal with a high resistance to high temperature and hardness. Very suitable also for non-ferrous metals.

AL41F

Sehr universell einsetzbare TIALN-Beschichtung mit hoher Temperaturbeständigkeit bei hoher Härte. Sehr gut geeignet auch für NE-Metalle.

TIALN coating - very universal with a high resistance to high temperature and hardness. Very suitable also for non-ferrous metals.

CN45F

Universell einsetzbare PVD-TIN-Beschichtung. Diese Allround-Sorte ist für niedrige und mittlere Schnittgeschwindigkeiten mit Einschränkung bei NE-Metallen.

PVD-TIN coating - all purpose, all around grade is suitable for low and medium cutting speed with restrictions on non-ferrous materials.

P18C

Universell einsetzbare Hochleistungsschicht mit hoher Oxidationsbeständigkeit, Verschleißfestigkeit und Warmhärte.

Very universal high performance coating with high oxidation resistance, wear resistance and hot hardness resistance.

P07C

Beschichtung für die Bearbeitung von Titan, Edelstahl und Molybdän.

Coating to machine titanium, stainless steel and molybdenum.



NUTSTOSSEN

Herstellung von Längsnuten
und Innenprofilen

broaching keyways
and internal profiles

Technische Hinweise

Hartmetallsorten und Beschichtungen

Technical instructions,
carbide grades and coatings

XC2A

Beschichtung mit einer exzellenten Warmhärte, Oxidationsbeständigkeit und thermischen Isolationsfähigkeit. Ideal für Hartzerspanung >60HRC

Coating with excellent hot hardness, high oxidation resistance and thermal insulation capacity. Ideal for hard machining >60 HRC.

P03C

Beschichtung für die Bearbeitung von schwer zerspanbaren Materialien. Sehr gut auch für die Trockenbearbeitung geeignet.

Coating for materials which are difficult to machine. Perfect to use for dry machining.

PD2F

Beschichtung für den universellen Einsatz bei niedrigen und mittleren Schnittgeschwindigkeiten.

Coating for universal use with medium and low speed.

NEME

Beschichtung für die Bearbeitung von Aluminium, Al-Legierungen, NE-Metallen und Kompositwerkstoffen.

Coating for machining aluminium, Al alloys, non-ferrous metals and composite materials.



NUTSTOSEN

Herstellung von Längsnuten und Innenprofilen

broaching keyways and internal profiles

Technische Hinweise

Schnittdatenempfehlung

Technical instructions, speed and feed recommendation

Richtwerte zum Nutenstossen

approximate value for broaching

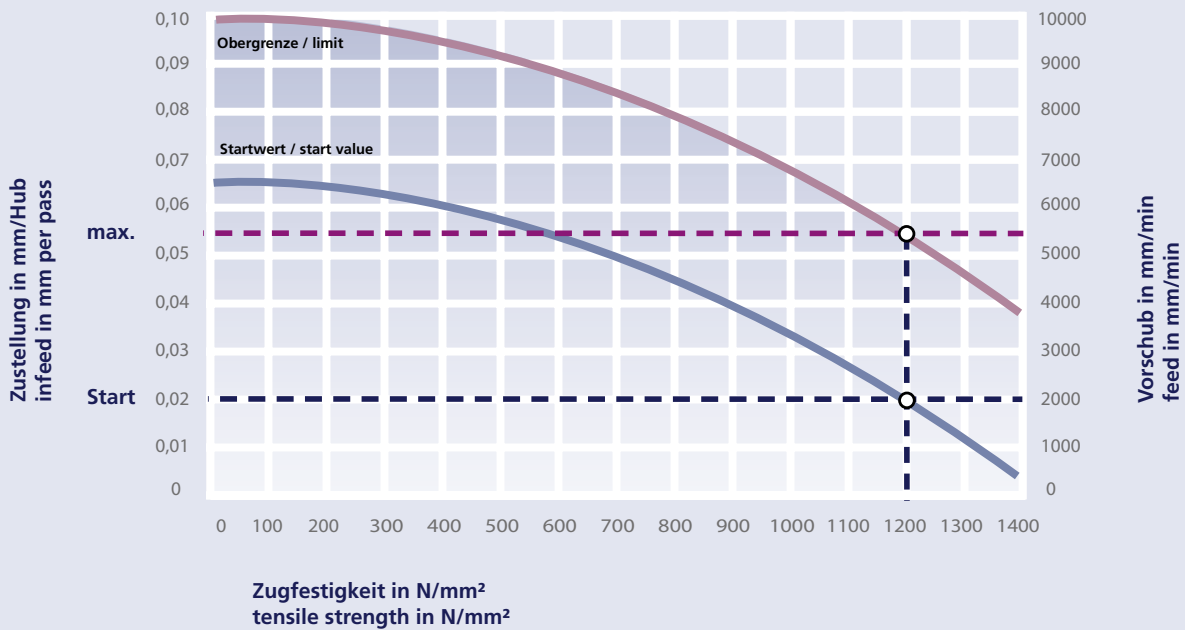

Beispiel:

Vergütungsstahl z.B. 42CrMo4 mit 1200 N/mm²

- Zustellung pro Hub 0.02 - 0.055 mm
- Vorschub 2000 - 5500 mm/min

example:

heat-treated steel for instance 42CrMo4 with 1200 N/mm²

- infeed per pass 0.02 - 0.055 mm
- feed 2000 - 5500 mm/min

NUTSTOSSEN

Herstellung von Längsnuten
und Innenprofilen

broaching keyways
and internal profiles

Impressionen

impressions

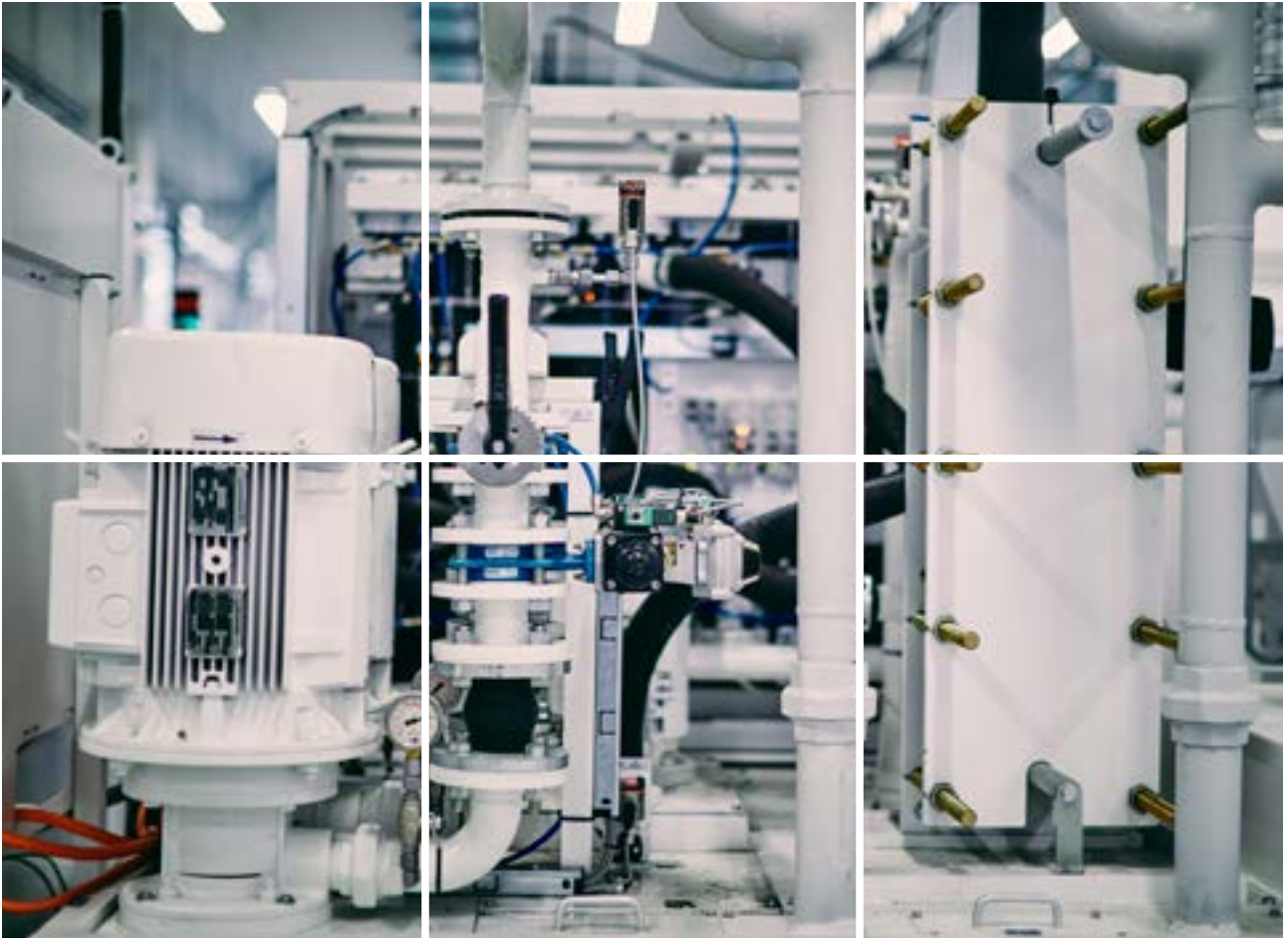

Notiz

notice



Notiz

notice

Area with horizontal dotted lines for writing.



Notiz

notice

A large central area with horizontal dotted lines for writing notes.



Notiz

notice



Notiz

notice

A large central area with horizontal dotted lines for writing notes.



Notiz

notice



Fräsen milling

Inhalt content

	FM-LINE	FM-LINE	DS \geq \varnothing 0.2 mm	07	
	MIKROMILL	MIKROMILL	D min. \geq \varnothing 4.0 mm Gewinde- $\varnothing \geq$ 1.0 x 0,25 mm thread- $\varnothing \geq$ 1.0 x 0,25 mm	08	
		MIKROMILL XL	DS \geq \varnothing 12.5 mm		
	MINIMILL	MINIMILL	D min. \geq \varnothing 7.0 mm	09	
		MINIMILL XL	DS = \varnothing 50 mm		
	SYSTEM 500	SYSTEM 500	DS \geq \varnothing 44 mm D min. \geq \varnothing 45 mm b \geq 1.41 mm	10	
	ROTALINE	ROTALINE	D min. \geq \varnothing 0.4 mm	11	
	AXALINE	AXALINE	D min. \geq \varnothing 5.0 mm	12	





FM - LINE

DS \geq \varnothing 0.2 mm

FM-LINE

VHM - Mikrofräser

solid carbide micro end mills

Übersicht

summary



Allgemeine Beschreibung

general instructions

... 4

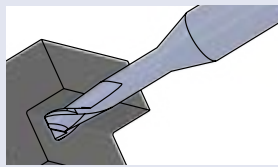

VHM - Mikrofräser

solid carbide
micro end mills

Maße
dimensions
[mm]

Seite
page

Typ FMR ...

VHM - Mikro - Torusfräser
mit Radius

solid carbide micro torus end mill
with radius

Ø DS 0.2 - 6.0

... 6

Typ FMF ...

VHM - Mikro - Schaftfräser
mit Fase 45°

solid carbide micro end mill
with chamfer 45°

Ø DS 0.2 - 3.0

... 12

Typ FMVR

VHM - Mikro - Vollradiusfräser

solid carbide micro ball nose end mill

Ø DS 0.2 - 3.0

... 17

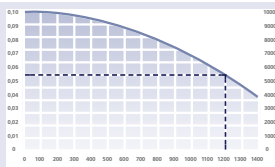

Technische Hinweise

Technical instructions

Seite
page

Hartmetallsorten und Beschichtungen

carbide grades and coatings

... 23

Schnittdatenempfehlung

speed and feed recommendation

... 24

FM-LINE

VHM - Mikrofräser

solid carbide micro end mills

Impressionen

impressions



FM-LINE

VHM - Mikrofräser

solid carbide micro end mills

Allgemeine Beschreibung

general instruction



FM-LINE:

Vollhartmetall Mikrofräser für den breiten Einsatz. Egal ob besäumen oder planfräsen, nutenfräsen oder 3D-Konturen abzeilen, diese Mikrofräser sind vielseitig einsetzbar.

Die FM-Line Werkzeuge sind in 3 Ausführungen ab Ø0.2 vorrätig. Als Torusfräser mit Radius bis Ø6, mit kleiner Fase bis Ø3 und als Vollradiusfräser bis Ø3.

FM-LINE:

Solid carbide micro end mills for a wide range of applications. Whether side or face milling, groove milling or 3D contours multipass milling, these micro end mills are versatile.

The FM-Line tools are available in 3 versions from Ø0.2. As a torus end mill with a radius up to Ø6, with a small chamfer up to Ø3 and as a full radius cutter up to Ø3.

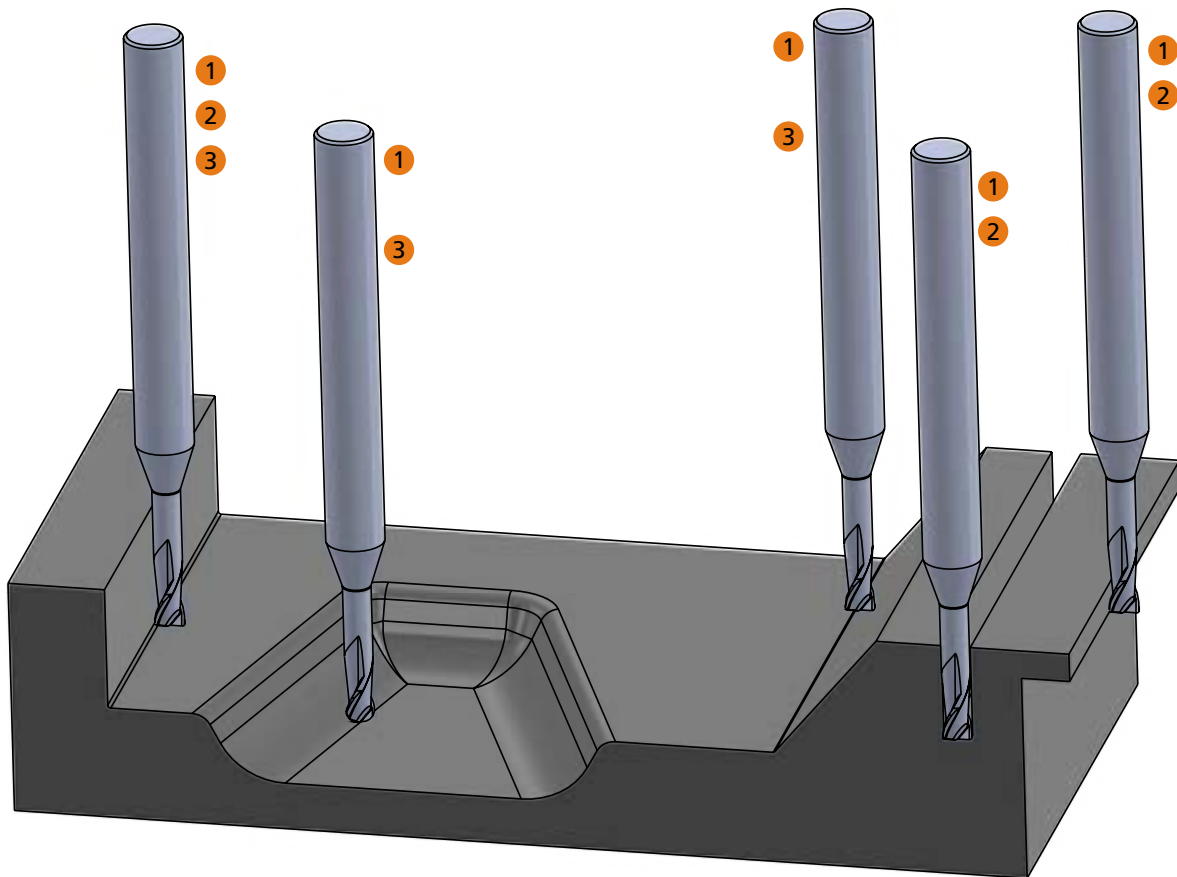

1

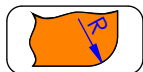

VHM - Mikro - Torusfräser mit Radius /
solid carbide micro torus end mill with radius

2

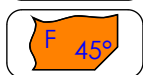

VHM - Mikro - Schaftfräser mit Fase 45° /
solid carbide micro end mill with chamfer 45°

3

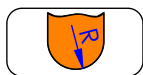

VHM - Mikro - Vollradiusfräser (mit Vollradius) /
solid carbide micro ball nose end mill (with full radius)

Anwendungsbeispiel
application example

FM-LINE

VHM - Mikrofräser

solid carbide micro end mills

Allgemeine Beschreibung

general instruction

Erklärung Symbole / Explanation of symbols

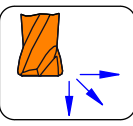
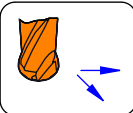
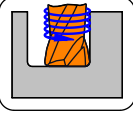
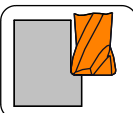
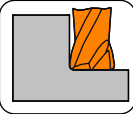
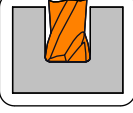
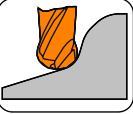
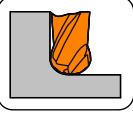
	Anzahl Schneiden / number of cutting edges
	Schneidrichtung / cutting direction: 1) Besäumen / slicing 2) Rampe / ramping 3) Bohrfräsen / bore milling (helical milling)
	Schneidrichtung / cutting direction: 1) Besäumen / slicing 2) Rampe, Kontur oder 3D Fräsen / ramping, contour or 3D milling
	Rampe / ramping
	Helikalfräsen / helical milling
	Besäumen, Trochoidales Fräsen / slicing, trochoidal milling
	Stirnfräsen / face milling
	Vollnutfräsen / groove milling
	Kontur oder 3D Fräsen / contour or 3D milling
	Besäumen, Kontur / slicing, contour milling



FM-LINE

VHM - Mikrofräser

solid carbide micro end mills

Typ FMR ...

VHM - Mikro - Torusfräser
mit Radius

solid carbide micro torus end mill
with radius

Fräser - Ø DS \triangleq 0.2 - 6.0 mm

mill - Ø DS \triangleq 0.2 - 6.0 mm

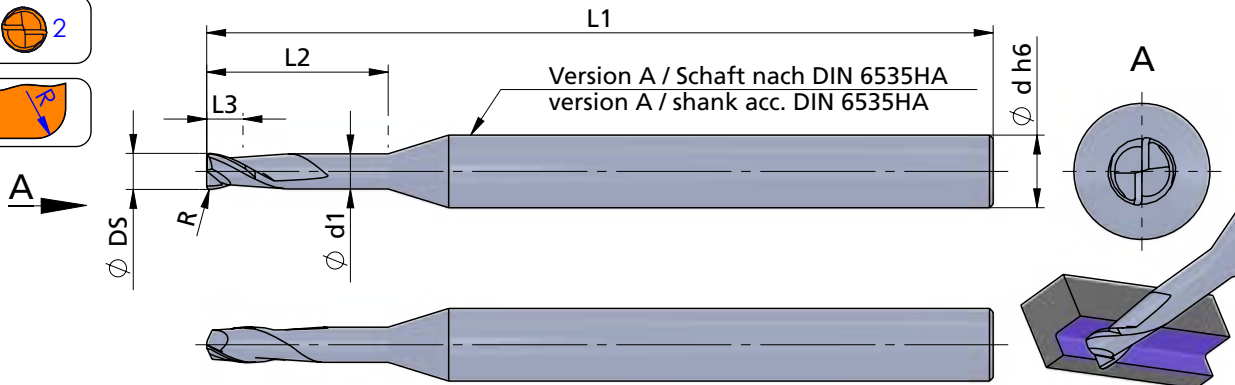
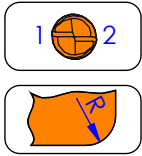
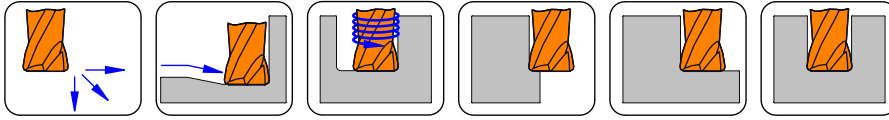

Beispielzeichnung
exemplary application

Schneidrichtung (R):
wie gezeichnet

cutting direction (R): as shown

Abmessungen in mm

dimensions in mm

Bestellnummer part number	Ø DS	R	Ø d h6	Ø d1	L1	L2 Bearbeitungslänge processing length	L3 Schneidlänge cutting length	P04C
FM0020.006.R02	0.2	0.02	6.0	0.18	55	0.6	0.2	●
FM0020.010.R02	0.2	0.02	6.0	0.18	55	1.0	0.2	●
FM0020.016.R02	0.2	0.02	6.0	0.18	55	1.6	0.5	●
FM0020.020.R02	0.2	0.02	6.0	0.18	55	2.0	0.5	●
FM0030.009.R03	0.3	0.03	6.0	0.28	55	0.9	0.5	●
FM0030.015.R03	0.3	0.03	6.0	0.28	55	1.5	0.5	●
FM0030.024.R03	0.3	0.03	6.0	0.28	55	2.4	1.2	●
FM0030.030.R03	0.3	0.03	6.0	0.28	55	3.0	1.2	●
FM0040.012.R04	0.4	0.04	6.0	0.37	55	1.2	0.5	●
FM0040.020.R04	0.4	0.04	6.0	0.37	55	2.0	1.2	●
FM0040.032.R04	0.4	0.04	6.0	0.37	55	3.2	1.2	●
FM0040.040.R04	0.4	0.04	6.0	0.37	55	4.0	1.2	●
↳ ...								

Informationen zu **ap max.** und **ae** siehe
Technische Hinweise.

Informations about **ap max.** and **ae** look at
the technical informations.

order-example:
grade P04C:
FM0020.006.R02/P04C

Bestellbeispiel:
für Sorte P04C:
FM0020.006.R02/P04C

FM-LINE

VHM - Mikrofräser

solid carbide micro end mills

Typ FMR ...

VHM - Mikro - Torusfräser mit Radius

solid carbide micro torus end mill with radius

Fräser - Ø DS \triangleq 0.2 - 6.0 mm

mill - Ø DS \triangleq 0.2 - 6.0 mm

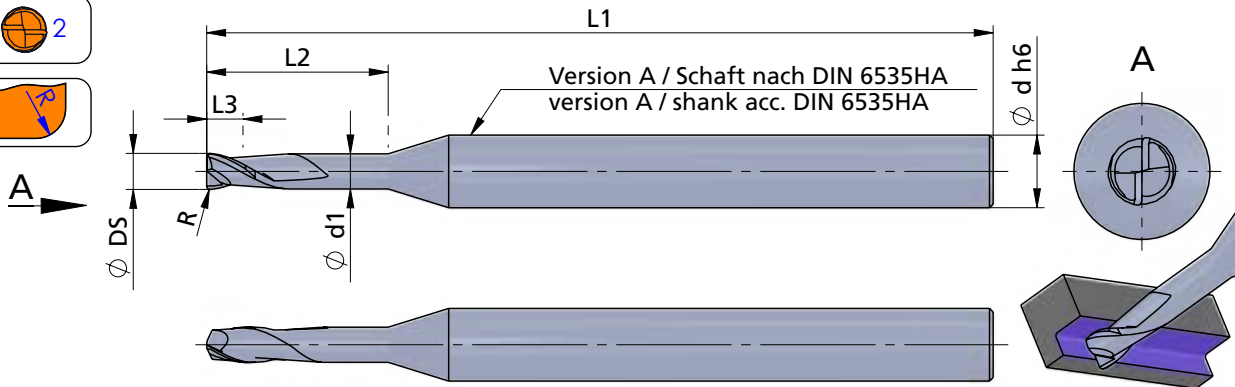
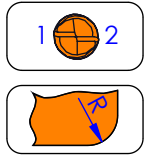
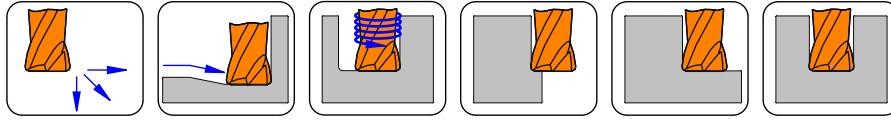

Beispielzeichnung
exemplary application

Schneidrichtung (R):
wie gezeichnet

cutting direction (R): as shown

Abmessungen in mm

dimensions in mm

Bestellnummer part number	Ø DS	R	Ø d h6	Ø d1	L1	L2 Bearbeitungslänge processing length	L3 Schneidlänge cutting length	P04C
...								
FM0050.015.R05	0.5	0.05	6.0	0.45	55	1.5	0.5	●
FM0050.025.R05	0.5	0.05	6.0	0.45	55	2.5	1.2	●
FM0050.040.R05	0.5	0.05	6.0	0.45	55	4.0	1.2	●
FM0050.050.R05	0.5	0.05	6.0	0.45	55	5.0	1.2	●
FM0060.020.R06	0.6	0.06	6.0	0.58	55	2.0	1.2	●
FM0060.030.R06	0.6	0.06	6.0	0.58	55	3.0	1.2	●
FM0060.050.R06	0.6	0.06	6.0	0.58	65	5.0	1.2	●
FM0060.060.R06	0.6	0.06	6.0	0.58	65	6.0	1.2	●
FM0080.025.R08	0.8	0.08	6.0	0.77	55	2.5	1.2	●
FM0080.040.R08	0.8	0.08	6.0	0.77	55	4.0	1.2	●
FM0080.065.R08	0.8	0.08	6.0	0.77	65	6.5	1.2	●
FM0080.080.R08	0.8	0.08	6.0	0.77	65	8.0	1.2	●
↳ ...								

Informationen zu **ap max.** und **ae** siehe Technische Hinweise.

Informations about **ap max.** and **ae** look at the technical informations.

Bestellbeispiel:
für Sorte P04C:
FM0050.015.R05/P04C

order-example:
grade P04C:
FM0050.015.R05/P04C

FM-LINE

VHM - Mikrofräser

solid carbide micro end mills

Typ FMR ...

VHM - Mikro - Torusfräser
mit Radius

solid carbide micro torus end mill
with radius

Fräser - Ø DS \triangleq 0.2 - 6.0 mm

mill - Ø DS \triangleq 0.2 - 6.0 mm

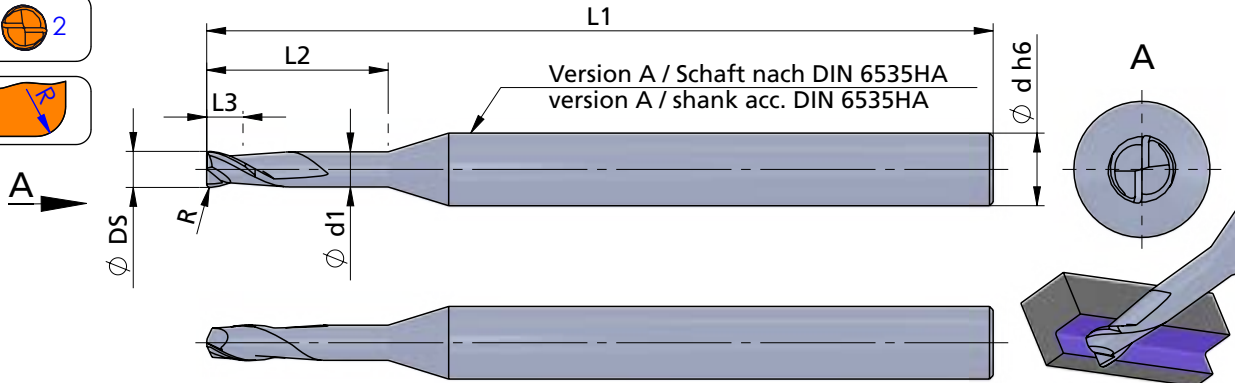
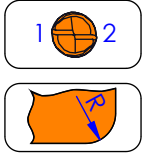
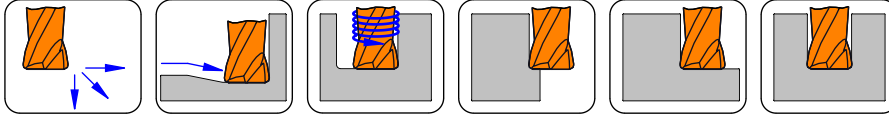

Beispielzeichnung
exemplary application

Schneidrichtung (R):
wie gezeichnet

cutting direction (R): as shown

Abmessungen in mm

dimensions in mm

Bestellnummer part number	Ø DS	R	Ø d h6	Ø d1	L1	L2 Bearbeitungslänge processing length	L3 Schneidlänge cutting length	P04C
...								
FM0100.030.R10	1.0	0.10	6.0	0.95	55	3.0	1.5	●
FM0100.050.R10	1.0	0.10	6.0	0.95	55	5.0	1.5	●
FM0100.080.R10	1.0	0.10	6.0	0.95	65	8.0	1.5	●
FM0100.100.R10	1.0	0.10	6.0	0.95	65	10.0	1.5	●
FM0100.120.R10	1.0	0.10	6.0	0.95	65	12.0	1.5	●
FM0120.030.R12	1.2	0.12	6.0	1.15	55	3.0	1.6	●
FM0120.060.R12	1.2	0.12	6.0	1.15	55	6.0	1.6	●
FM0120.100.R12	1.2	0.12	6.0	1.15	65	10.0	1.6	●
FM0120.120.R12	1.2	0.12	6.0	1.15	65	12.0	1.6	●
FM0130.040.R13	1.3	0.13	6.0	1.25	55	4.0	1.7	●
FM0130.070.R13	1.3	0.13	6.0	1.25	55	7.0	1.7	●
FM0130.110.R13	1.3	0.13	6.0	1.25	65	11.0	1.7	●
FM0130.120.R13	1.3	0.13	6.0	1.25	65	12.0	1.7	●
FM0130.130.R13	1.3	0.13	6.0	1.25	65	13.0	1.7	●
↳ ...								

Informationen zu **ap max.** und **ae** siehe
Technische Hinweise.

Informations about **ap max.** and **ae** look at
the technical informations.

order-example:
grade P04C:
FM0100.030.R10/P04C

Bestellbeispiel:
für Sorte P04C:
FM0100.030.R10/P04C

FM-LINE

VHM - Mikrofräser

solid carbide micro end mills

Typ FMR ...

VHM - Mikro - Torusfräser mit Radius

solid carbide micro torus end mill with radius

Fräser - Ø DS \triangleq 0.2 - 6.0 mm

mill - Ø DS \triangleq 0.2 - 6.0 mm

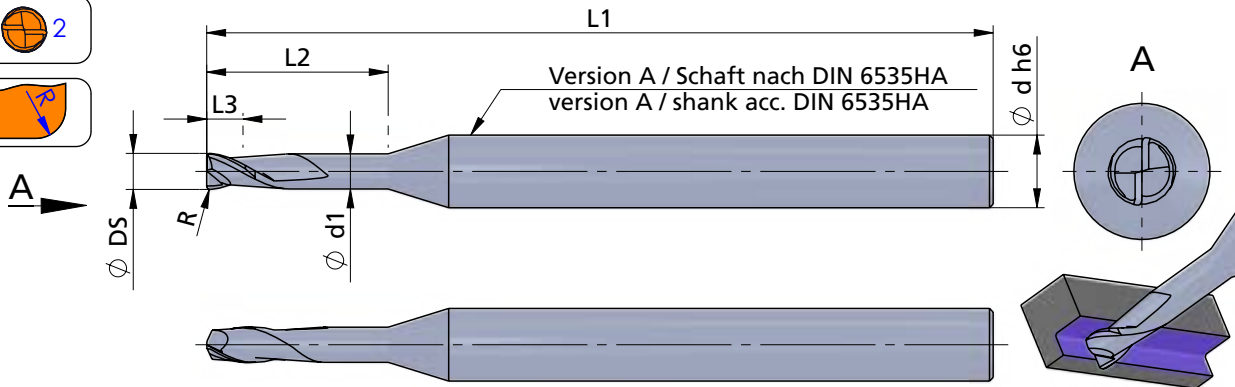
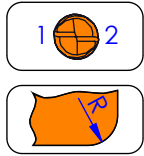
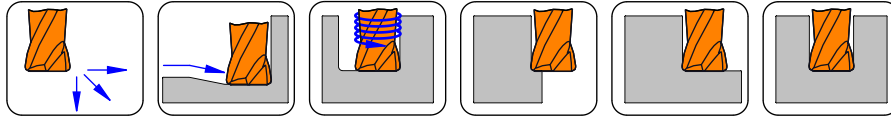

Beispielzeichnung
exemplary application

Schneidrichtung (R):
wie gezeichnet

cutting direction (R): as shown

Abmessungen in mm

dimensions in mm

Bestellnummer part number	Ø DS	R	Ø d h6	Ø d1	L1	L2 Bearbeitungslänge processing length	L3 Schneidlänge cutting length	P04C
...								
FM0150.050.R15	1.5	0.15	6.0	1.44	55	5.0	1.8	●
FM0150.075.R15	1.5	0.15	6.0	1.44	55	7.5	1.8	●
FM0150.120.R15	1.5	0.15	6.0	1.44	65	12.0	1.8	●
FM0150.150.R15	1.5	0.15	6.0	1.44	65	15.0	1.8	●
FM0160.050.R16	1.6	0.16	6.0	1.52	55	5.0	1.8	●
FM0160.080.R16	1.6	0.16	6.0	1.52	55	8.0	1.8	●
FM0160.130.R16	1.6	0.16	6.0	1.52	65	13.0	1.8	●
FM0160.160.R16	1.6	0.16	6.0	1.52	65	16.0	1.8	●
FM0180.055.R18	1.8	0.18	6.0	1.72	55	5.5	1.8	●
FM0180.090.R18	1.8	0.18	6.0	1.72	55	9.0	1.8	●
FM0180.145.R18	1.8	0.18	6.0	1.72	65	14.5	1.8	●
FM0180.180.R18	1.8	0.18	6.0	1.72	65	18.0	1.8	●
↳ ...								

Informationen zu **ap max.** und **ae** siehe Technische Hinweise.

Informations about **ap max.** and **ae** look at the technical informations.

Bestellbeispiel:
für Sorte P04C:
FM0150.050.R15/P04C

order-example:
grade P04C:
FM0150.050.R15/P04C

FM-LINE

VHM - Mikrofräser

solid carbide micro end mills

Typ FMR ...

VHM - Mikro - Torusfräser
mit Radius

solid carbide micro torus end mill
with radius

Fräser - Ø DS \triangleq 0.2 - 6.0 mm

mill - Ø DS \triangleq 0.2 - 6.0 mm

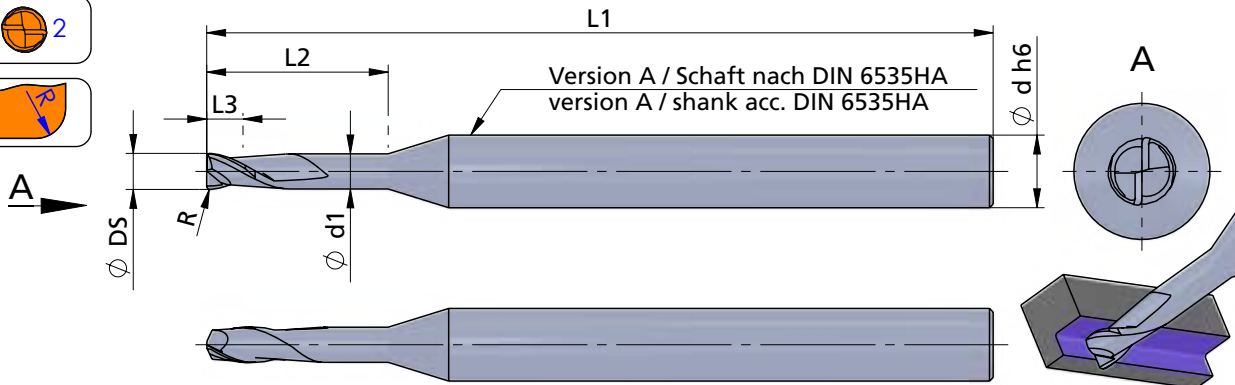
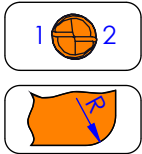
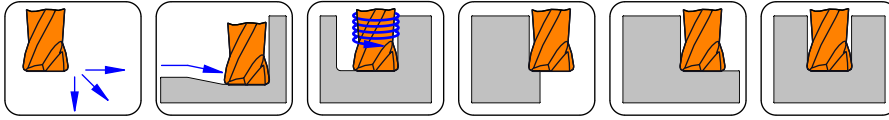

Schneidrichtung (R):
wie gezeichnet

cutting direction (R): as shown

Abmessungen in mm

dimensions in mm

Bestellnummer part number	Ø DS	R	Ø d h6	Ø d1	L1	L2 Bearbeitungslänge processing length	L3 Schneidlänge cutting length	P04C
...								
FM0200.060.R20	2.0	0.20	6.0	1.92	55	6.0	2.0	●
FM0200.100.R20	2.0	0.20	6.0	1.92	55	10.0	2.0	●
FM0200.140.R20	2.0	0.20	6.0	1.92	55	14.0	2.0	●
FM0200.160.R20	2.0	0.20	6.0	1.92	65	16.0	2.0	●
FM0200.200.R20	2.0	0.20	6.0	1.92	65	20.0	2.0	●
FM0230.070.R23	2.3	0.23	6.0	2.22	55	7.0	2.3	●
FM0230.115.R23	2.3	0.23	6.0	2.22	55	11.5	2.3	●
FM0230.185.R23	2.3	0.23	6.0	2.22	65	18.5	2.3	●
FM0230.200.R23	2.3	0.23	6.0	2.22	65	20.0	2.3	●
FM0230.230.R23	2.3	0.23	6.0	2.22	65	23.0	2.3	●
FM0300.090.R30	3.0	0.30	6.0	2.90	65	9.0	3.0	●
FM0300.150.R30	3.0	0.30	6.0	2.90	65	15.0	3.0	●
FM0300.240.R30	3.0	0.30	6.0	2.90	100	24.0	3.0	●
FM0300.300.R30	3.0	0.30	6.0	2.90	100	30.0	3.0	●
↳ ...								

Informationen zu **ap max.** und **ae** siehe
Technische Hinweise.

Informations about **ap max.** and **ae** look at
the technical informations.

order-example:
grade P04C:
FM0200.060.R20/P04C

FM-LINE

VHM - Mikrofräser

solid carbide micro end mills

Typ FMR ...

VHM - Mikro - Torusfräser mit Radius

solid carbide micro torus end mill with radius

Fräser - Ø DS \triangleq 0.2 - 6.0 mm

mill - Ø DS \triangleq 0.2 - 6.0 mm

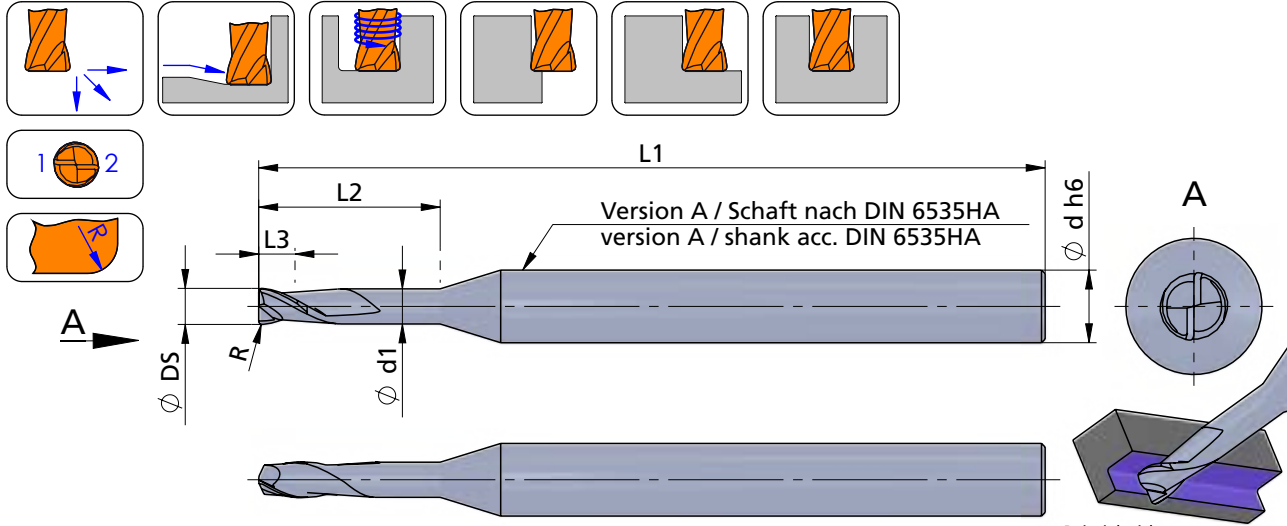

Beispielzeichnung
exemplary application

Schneidrichtung (R):
wie gezeichnet

cutting direction (R): as shown

Abmessungen in mm

dimensions in mm

Bestellnummer part number	Ø DS	R	Ø d h6	Ø d1	L1	L2 Bearbeitungslänge processing length	L3 Schneidenlänge cutting length	P04C
...								
FM0400.120.R40	4.0	0.40	6.0	3.90	65	12.0	4.0	●
FM0400.200.R40	4.0	0.40	6.0	3.90	65	20.0	4.0	●
FM0400.320.R40	4.0	0.40	6.0	3.90	100	32.0	4.0	●
FM0400.400.R40	4.0	0.40	6.0	3.90	100	40.0	4.0	●
FM0500.150.R50	5.0	0.50	6.0	4.90	65	15.0	5.0	●
FM0500.250.R50	5.0	0.50	6.0	4.90	65	25.0	5.0	●
FM0500.400.R50	5.0	0.50	6.0	4.90	100	40.0	5.0	●
FM0500.500.R50	5.0	0.50	6.0	4.90	100	50.0	5.0	●
FM0600.180.R60	6.0	0.60	6.0	5.90	65	18.0	6.0	●
FM0600.300.R60	6.0	0.60	6.0	5.90	100	30.0	6.0	●
FM0600.480.R60	6.0	0.60	6.0	5.90	100	48.0	6.0	●
FM0600.600.R60	6.0	0.60	6.0	5.90	100	60.0	6.0	●

Bestellbeispiel:
für Sorte P04C:
FM0400.120.R40/P04C

Informationen zu **ap max.** und **ae** siehe Technische Hinweise.

Informations about **ap max.** and **ae** look at the technical informations.

order-example:
grade P04C:
FM0400.120.R40/P04C

FM-LINE

VHM - Mikrofräser

solid carbide micro end mills

Typ FMF ...

VHM - Mikro - Schaftfräser
mit Fase 45°

solid carbide micro end mill
with chamfer 45°

Fräser - Ø DS \triangleq 0.2 - 3.0 mm

mill - Ø DS \triangleq 0.2 - 3.0 mm

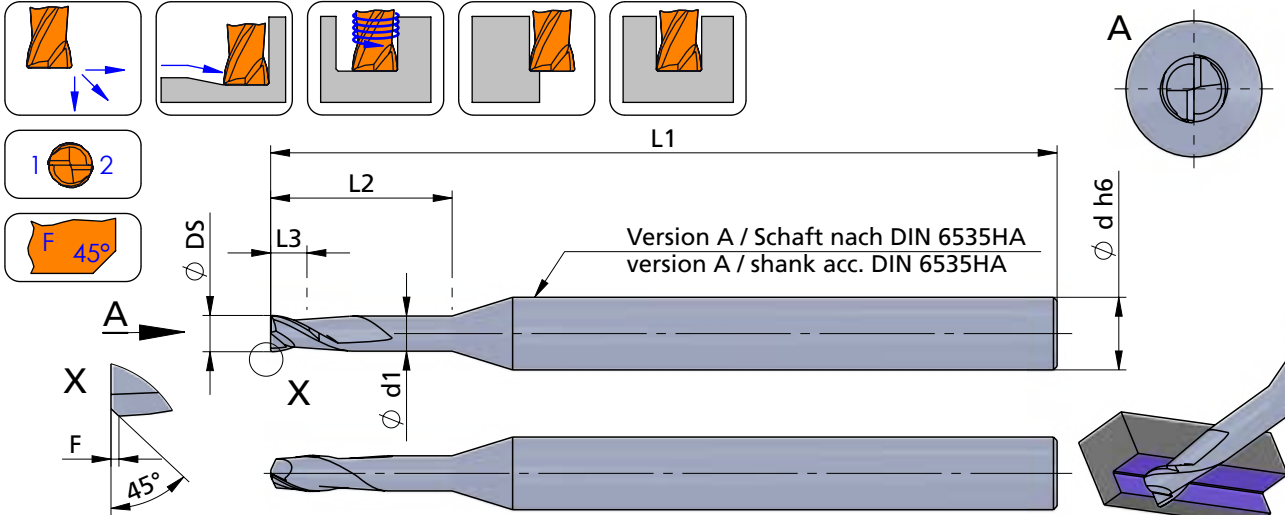

Beispielzeichnung
exemplary application

Schneidrichtung (R):
wie gezeichnet

cutting direction (R): as shown

Abmessungen in mm

dimensions in mm

Bestellnummer part number	Ø DS	F	Ø d h6	Ø d1	L1	L2 Bearbeitungslänge processing length	L3 Schneidlänge cutting length	P04C
FM0020.006.F02	0.2	0.02	6.0	0.18	55	0.6	0.2	●
FM0020.010.F02	0.2	0.02	6.0	0.18	55	1.0	0.2	●
FM0020.016.F02	0.2	0.02	6.0	0.18	55	1.6	0.5	●
FM0020.020.F02	0.2	0.02	6.0	0.18	55	2.0	0.5	●
FM0030.009.F03	0.3	0.03	6.0	0.28	55	0.9	0.5	●
FM0030.015.F03	0.3	0.03	6.0	0.28	55	1.5	0.5	●
FM0030.024.F03	0.3	0.03	6.0	0.28	55	2.4	1.2	●
FM0030.030.F03	0.3	0.03	6.0	0.28	55	3.0	1.2	●
FM0040.012.F04	0.4	0.04	6.0	0.37	55	1.2	0.5	●
FM0040.020.F04	0.4	0.04	6.0	0.37	55	2.0	1.2	●
FM0040.032.F04	0.4	0.04	6.0	0.37	55	3.2	1.2	●
FM0040.040.F04	0.4	0.04	6.0	0.37	55	4.0	1.2	●
↳ ...								

Informationen zu **ap max.** und **ae** siehe
Technische Hinweise.

Informations about **ap max.** and **ae** look at
the technical informations.

order-example:
grade P04C:
FM0020.006.F02/P04C

FM-LINE

VHM - Mikrofräser

solid carbide micro end mills

Typ FMF ...

VHM - Mikro - Schaftfräser
mit Fase 45°

solid carbide micro end mill
with chamfer 45°

Fräser - Ø DS \triangleq 0.2 - 3.0 mm

mill - Ø DS \triangleq 0.2 - 3.0 mm

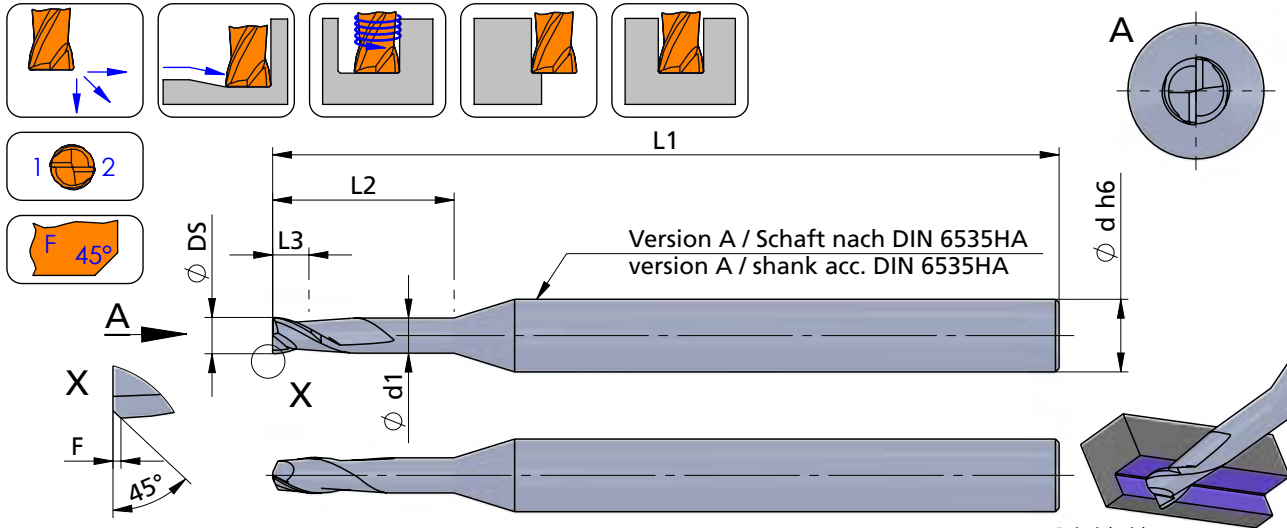

Beispielzeichnung
exemplary application

Schneidrichtung (R):
wie gezeichnet

cutting direction (R): as shown

Abmessungen in mm

dimensions in mm

Bestellnummer part number	Ø DS	F	Ø d h6	Ø d1	L1	L2 Bearbeitungslänge processing length	L3 Schneidenlänge cutting length	P04C
... ↴								
FM0050.015.F05	0.5	0.05	6.0	0.45	55	1.5	0.5	●
FM0050.025.F05	0.5	0.05	6.0	0.45	55	2.5	1.2	●
FM0050.040.F05	0.5	0.05	6.0	0.45	55	4.0	1.2	●
FM0050.050.F05	0.5	0.05	6.0	0.45	55	5.0	1.2	●
FM0060.020.F06	0.6	0.06	6.0	0.58	55	2.0	1.2	●
FM0060.030.F06	0.6	0.06	6.0	0.58	55	3.0	1.2	●
FM0060.050.F06	0.6	0.06	6.0	0.58	65	5.0	1.2	●
FM0060.060.F06	0.6	0.06	6.0	0.58	65	6.0	1.2	●
FM0080.025.F08	0.8	0.08	6.0	0.77	55	2.5	1.2	●
FM0080.040.F08	0.8	0.08	6.0	0.77	55	4.0	1.2	●
FM0080.065.F08	0.8	0.08	6.0	0.77	65	6.5	1.2	●
FM0080.080.F08	0.8	0.08	6.0	0.77	65	8.0	1.2	●
↳ ...								

Informationen zu **ap max.** und **ae** siehe
Technische Hinweise.

Informations about **ap max.** and **ae** look at
the technical informations.

Bestellbeispiel:
für Sorte P04C:
FM0050.015.F05/P04C

order-example:
grade P04C:
FM0050.015.F05/P04C

FM-LINE

VHM - Mikrofräser

solid carbide micro end mills

Typ FMF ...

VHM - Mikro - Schaftfräser
mit Fase 45°

solid carbide micro end mill
with chamfer 45°

Fräser - Ø DS \triangleq 0.2 - 3.0 mm

mill - Ø DS \triangleq 0.2 - 3.0 mm

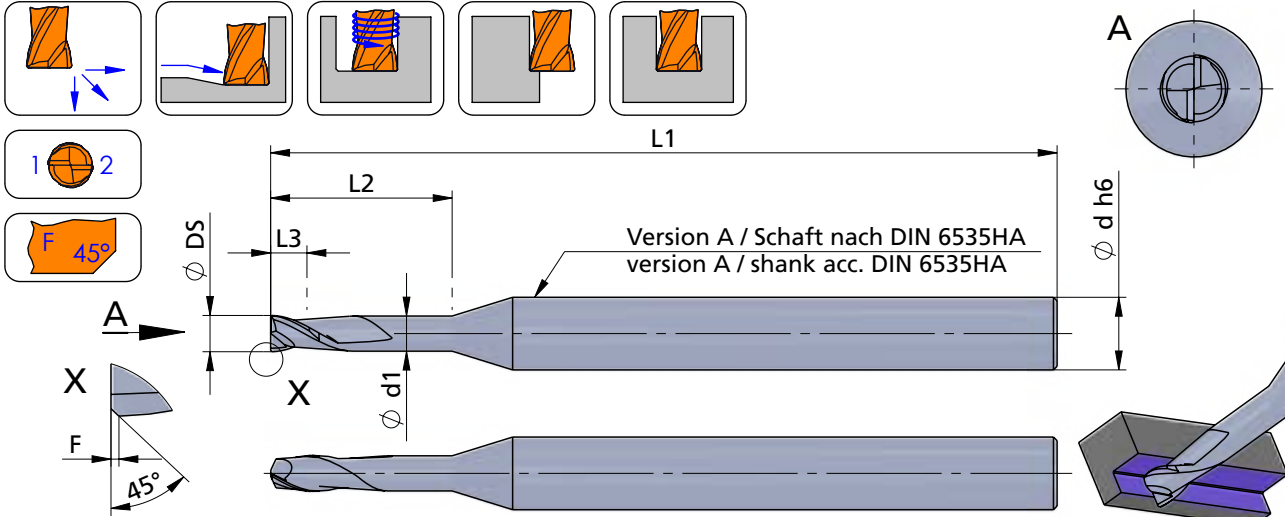

Beispielzeichnung
exemplary application

Schneidrichtung (R):
wie gezeichnet

cutting direction (R): as shown

Abmessungen in mm

dimensions in mm

Bestellnummer part number	Ø DS	F	Ø d h6	Ø d1	L1	L2 Bearbeitungslänge processing length	L3 Schneidlänge cutting length	P04C
... ↘								
FM0100.030.F10	1.0	0.10	6.0	0.95	55	3.0	1.5	●
FM0100.050.F10	1.0	0.10	6.0	0.95	55	5.0	1.5	●
FM0100.080.F10	1.0	0.10	6.0	0.95	65	8.0	1.5	●
FM0100.100.F10	1.0	0.10	6.0	0.95	65	10.0	1.5	●
FM0100.120.F10	1.0	0.10	6.0	0.95	65	12.0	1.5	●
FM0120.030.F10	1.2	0.10	6.0	1.15	55	3.0	1.6	●
FM0120.060.F10	1.2	0.10	6.0	1.15	55	6.0	1.6	●
FM0120.100.F10	1.2	0.10	6.0	1.15	65	10.0	1.6	●
FM0120.120.F10	1.2	0.10	6.0	1.15	65	12.0	1.6	●
FM0130.040.F10	1.3	0.10	6.0	1.25	55	4.0	1.7	●
FM0130.070.F10	1.3	0.10	6.0	1.25	55	7.0	1.7	●
FM0130.110.F10	1.3	0.10	6.0	1.25	65	11.0	1.7	●
FM0130.130.F10	1.3	0.10	6.0	1.25	65	13.0	1.7	●
↳ ...								

Informationen zu **ap max.** und **ae** siehe
Technische Hinweise.

Informations about **ap max.** and **ae** look at
the technical informations.

order-example:
grade P04C:
FM0100.030.F10/P04C

FM-LINE

VHM - Mikrofräser

solid carbide micro end mills

Typ FMF ...

VHM - Mikro - Schaftfräser
mit Fase 45°

solid carbide micro end mill
with chamfer 45°

Fräser - Ø DS \triangleq 0.2 - 3.0 mm

mill - Ø DS \triangleq 0.2 - 3.0 mm

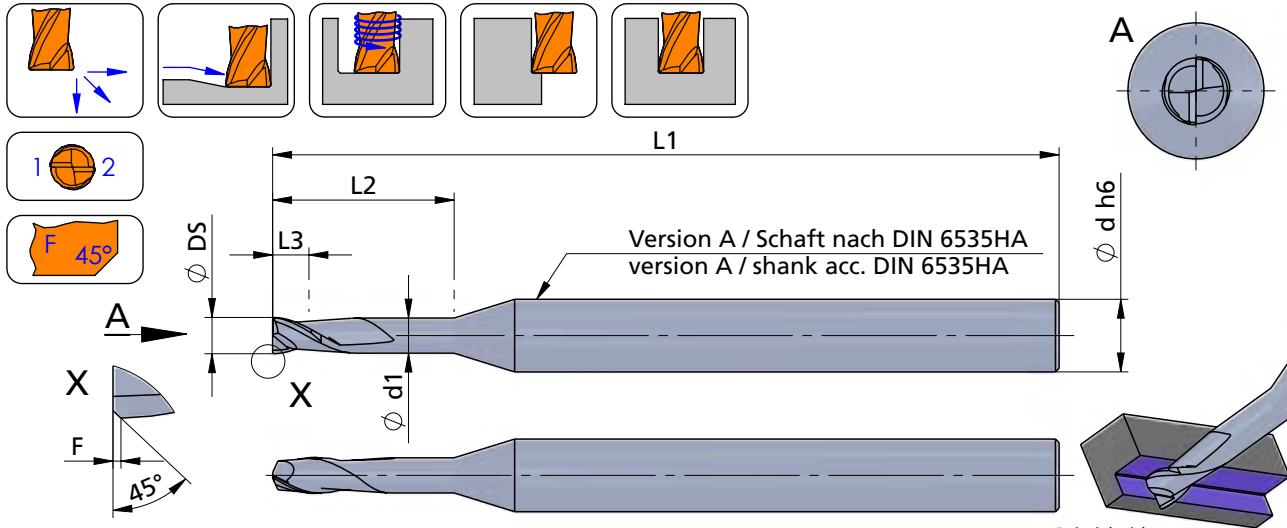

Beispielzeichnung
exemplary application

Schneidrichtung (R):
wie gezeichnet

cutting direction (R): as shown

Abmessungen in mm

dimensions in mm

Bestellnummer part number	Ø DS	F	Ø d h6	Ø d1	L1	L2 Bearbeitungslänge processing length	L3 Schneidlänge cutting length	P04C
... ↴								
FM0150.050.F10	1.5	0.10	6.0	1.44	55	5.0	1.8	●
FM0150.075.F10	1.5	0.10	6.0	1.44	55	7.5	1.8	●
FM0150.120.F10	1.5	0.10	6.0	1.44	65	12.0	1.8	●
FM0150.150.F10	1.5	0.10	6.0	1.44	65	15.0	1.8	●
FM0160.050.F10	1.6	0.10	6.0	1.52	55	5.0	1.8	●
FM0160.080.F10	1.6	0.10	6.0	1.52	55	8.0	1.8	●
FM0160.130.F10	1.6	0.10	6.0	1.52	65	13.0	1.8	●
FM0160.160.F10	1.6	0.10	6.0	1.52	65	16.0	1.8	●
FM0180.055.F10	1.8	0.10	6.0	1.72	55	5.5	1.8	●
FM0180.090.F10	1.8	0.10	6.0	1.72	55	9.0	1.8	●
FM0180.145.F10	1.8	0.10	6.0	1.72	65	14.5	1.8	●
FM0180.180.F10	1.8	0.10	6.0	1.72	65	18.0	1.8	●
↳ ...								

Informationen zu **ap max.** und **ae** siehe Technische Hinweise.

Information about **ap max.** and **ae** look at the technical informations.

Bestellbeispiel:
für Sorte P04C:
FM0150.050.F10/P04C

order-example:
grade P04C:
FM0150.050.F10/P04C

FM-LINE

VHM - Mikrofräser

solid carbide micro end mills

Typ FMF ...

VHM - Mikro - Schaftfräser
mit Fase 45°

solid carbide micro end mill
with chamfer 45°

Fräser - Ø DS \triangleq 0.2 - 3.0 mm

mill - Ø DS \triangleq 0.2 - 3.0 mm

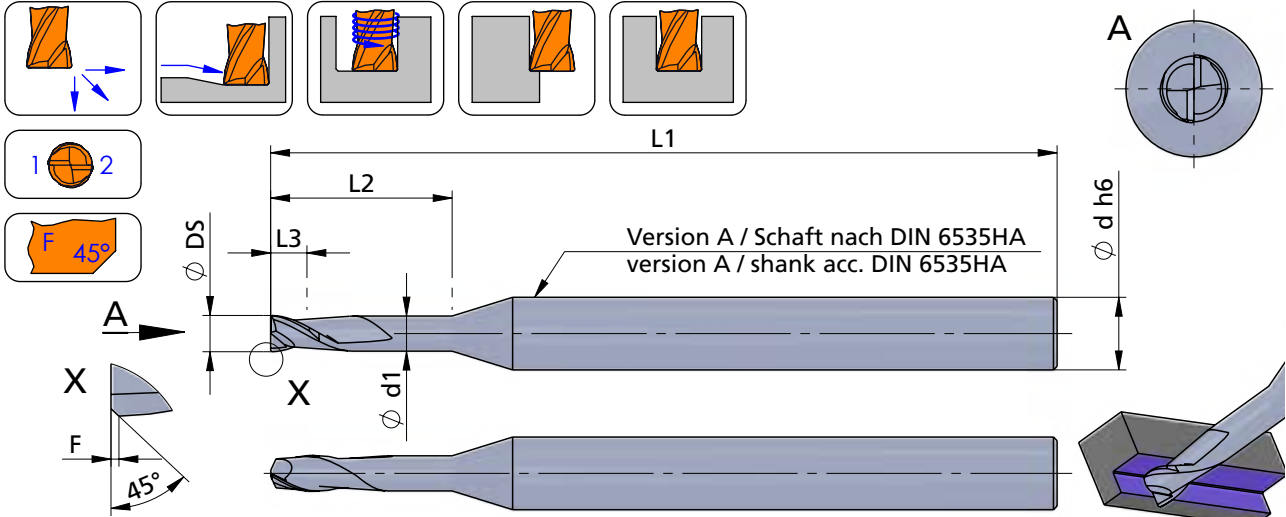

Beispielzeichnung
exemplary application

Schneidrichtung (R):
wie gezeichnet

cutting direction (R): as shown

Abmessungen in mm

dimensions in mm

Bestellnummer part number	Ø DS	F	Ø d h6	Ø d1	L1	L2 Bearbeitungslänge processing length	L3 Schneidenlänge cutting length	P04C
...								
FM0200.060.F10	2.0	0.10	6.0	1.92	55	6.0	2.0	●
FM0200.100.F10	2.0	0.10	6.0	1.92	55	10.0	2.0	●
FM0200.140.F10	2.0	0.10	6.0	1.92	55	14.0	2.0	●
FM0200.160.F10	2.0	0.10	6.0	1.92	65	16.0	2.0	●
FM0200.200.F10	2.0	0.10	6.0	1.92	65	20.0	2.0	●
FM0230.070.F10	2.3	0.10	6.0	2.22	55	7.0	2.3	●
FM0230.115.F10	2.3	0.10	6.0	2.22	55	11.5	2.3	●
FM0230.185.F10	2.3	0.10	6.0	2.22	65	18.5	2.3	●
FM0230.230.F10	2.3	0.10	6.0	2.22	65	23.0	2.3	●
FM0300.090.F10	3.0	0.10	6.0	2.90	65	9.0	3.0	●
FM0300.150.F10	3.0	0.10	6.0	2.90	65	15.0	3.0	●
FM0300.240.F10	3.0	0.10	6.0	2.90	100	24.0	3.0	●
FM0300.300.F10	3.0	0.10	6.0	2.90	100	30.0	3.0	●

Informationen zu **ap max.** und **ae** siehe
Technische Hinweise.

Informations about **ap max.** and **ae** look at
the technical informations.

order-example:
grade P04C:
FM0200.060.F10/P04C

FM-LINE

VHM - Mikrofräser

solid carbide micro end mills

Typ FMVR ...

VHM - Mikro - Vollradiusfräser

Fräser - Ø DS \triangleq 0.2 - 3.0 mm

solid carbide micro ball nose end mill

mill - Ø DS \triangleq 0.2 - 3.0 mm

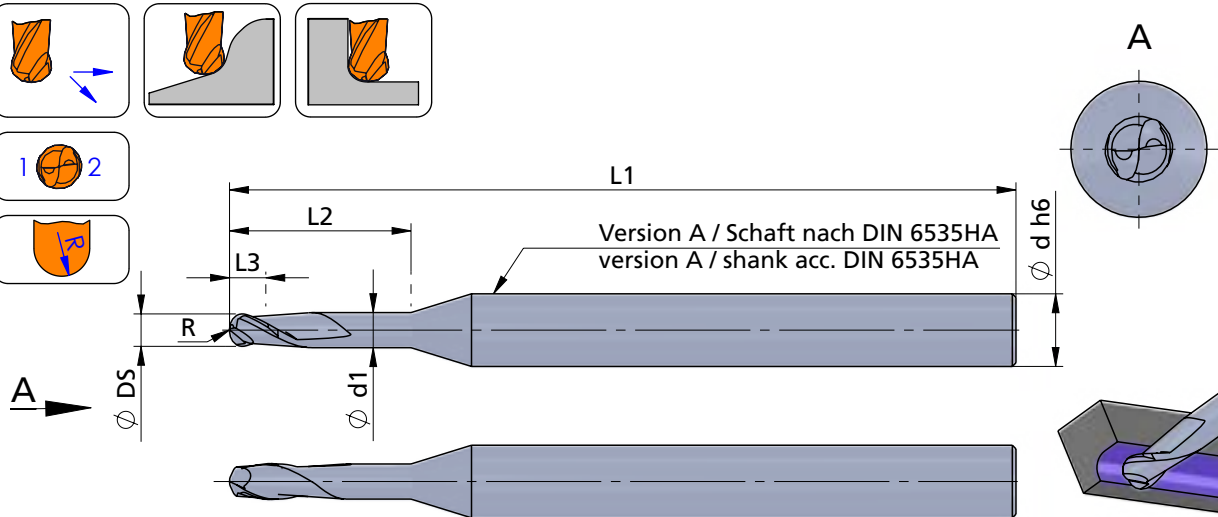
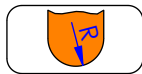
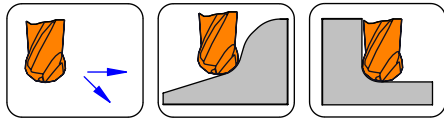

Beispielzeichnung
exemplary application

Schneidrichtung (R):
wie gezeichnet

cutting direction (R): as shown

Abmessungen in mm

dimensions in mm

Bestellnummer part number	Ø DS	R	Ø d h6	Ø d1	L1	L2 Bearbeitungslänge processing length	L3 Schneidlänge cutting length	P04C
FM0020.006.VR	0.2	0.10	6.0	0.18	55	0.6	0.2	●
FM0020.010.VR	0.2	0.10	6.0	0.18	55	1.0	0.2	●
FM0020.016.VR	0.2	0.10	6.0	0.18	55	1.6	0.5	●
FM0020.020.VR	0.2	0.10	6.0	0.18	55	2.0	0.5	●
FM0030.009.VR	0.3	0.15	6.0	0.28	55	0.9	0.5	●
FM0030.015.VR	0.3	0.15	6.0	0.28	55	1.5	0.5	●
FM0030.024.VR	0.3	0.15	6.0	0.28	55	2.4	1.2	●
FM0030.030.VR	0.3	0.15	6.0	0.28	55	3.0	1.2	●
FM0040.012.VR	0.4	0.20	6.0	0.37	55	1.2	0.5	●
FM0040.020.VR	0.4	0.20	6.0	0.37	55	2.0	1.2	●
FM0040.032.VR	0.4	0.20	6.0	0.37	55	3.2	1.2	●
FM0040.040.VR	0.4	0.20	6.0	0.37	55	4.0	1.2	●
↳ ...								

Informationen zu **ap max.** und **ae** siehe Technische Hinweise.

Informations about **ap max.** and **ae** look at the technical informations.

Bestellbeispiel:
für Sorte P04C:
FM0020.006.VR/P04C

order-example:
grade P04C:
FM0020.006.VR/P04C

FM-LINE

VHM - Mikrofräser

solid carbide micro end mills

Typ FMVR ...

VHM - Mikro - Vollradiusfräser

Fräser - Ø DS \triangleq 0.2 - 3.0 mm

solid carbide micro ball nose end mill

mill - Ø DS \triangleq 0.2 - 3.0 mm

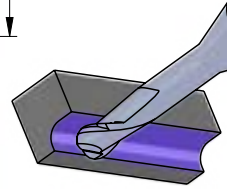
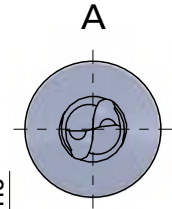
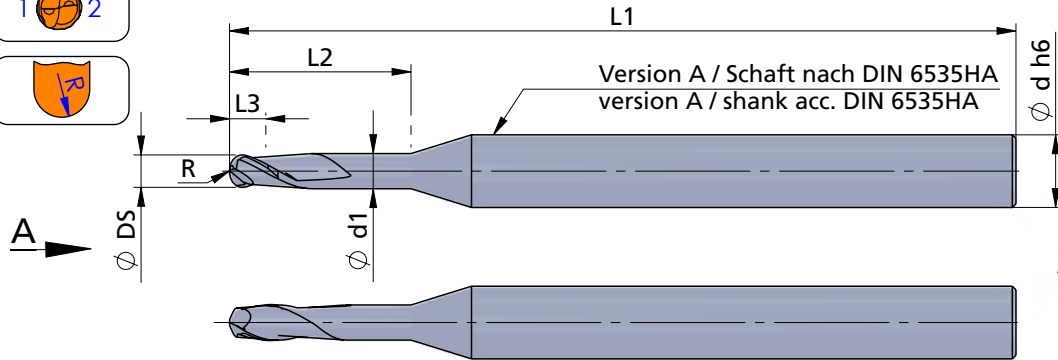
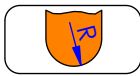
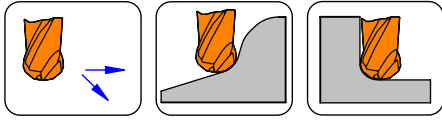

Beispielzeichnung
exemplary application

Schneidrichtung (R):
wie gezeichnet

cutting direction (R): as shown

Abmessungen in mm

dimensions in mm

Bestellnummer part number	Ø DS	R	Ø d h6	Ø d1	L1	L2 Bearbeitungslänge processing length	L3 Schneidlänge cutting length	P04C
... ↴								
FM0050.015.VR	0.5	0.25	6.0	0.45	55	1.5	0.5	●
FM0050.025.VR	0.5	0.25	6.0	0.45	55	2.5	1.2	●
FM0050.040.VR	0.5	0.25	6.0	0.45	55	4.0	1.2	●
FM0050.050.VR	0.5	0.25	6.0	0.45	55	5.0	1.2	●
FM0060.020.VR	0.6	0.30	6.0	0.58	55	2.0	1.2	●
FM0060.030.VR	0.6	0.30	6.0	0.58	55	3.0	1.2	●
FM0060.050.VR	0.6	0.30	6.0	0.58	65	5.0	1.2	●
FM0060.060.VR	0.6	0.30	6.0	0.58	65	6.0	1.2	●
FM0080.025.VR	0.8	0.40	6.0	0.77	55	2.5	1.2	●
FM0080.040.VR	0.8	0.40	6.0	0.77	55	4.0	1.2	●
FM0080.065.VR	0.8	0.40	6.0	0.77	65	6.5	1.2	●
FM0080.080.VR	0.8	0.40	6.0	0.77	65	8.0	1.2	●
↳ ...								

Informationen zu **ap max.** und **ae** siehe
Technische Hinweise.

Informations about **ap max.** and **ae** look at
the technical informations.

order-example:
grade P04C:
FM0050.015.VR/P04C

Bestellbeispiel:
für Sorte P04C:
FM0050.015.VR/P04C

FM-LINE

VHM - Mikrofräser

solid carbide micro end mills

Typ FMVR ...

VHM - Mikro - Vollradiusfräser

Fräser - Ø DS \triangleq 0.2 - 3.0 mm

solid carbide micro ball nose end mill

mill - Ø DS \triangleq 0.2 - 3.0 mm

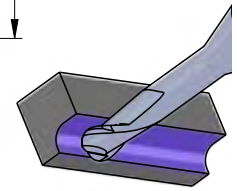
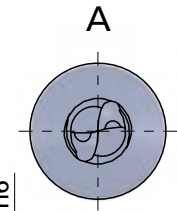
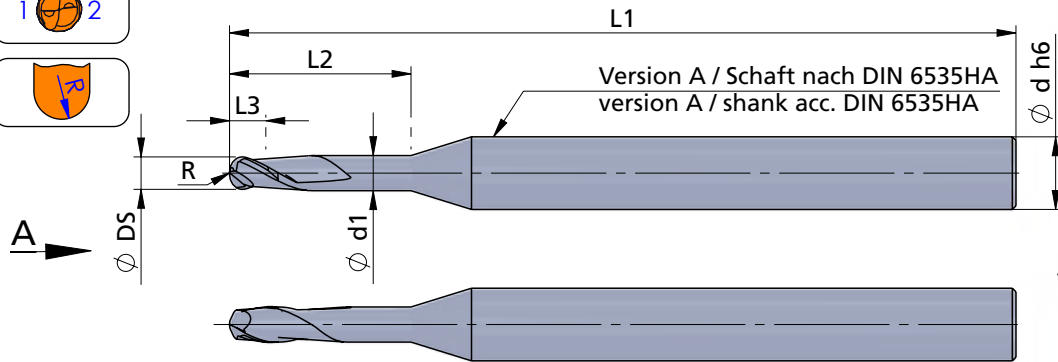
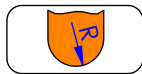
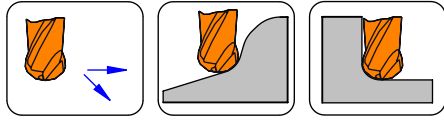

Beispielzeichnung
exemplary application

Schneidrichtung (R):
wie gezeichnet

cutting direction (R): as shown

Abmessungen in mm

dimensions in mm

Bestellnummer part number	Ø DS	R	Ø d h6	Ø d1	L1	L2 Bearbeitungslänge processing length	L3 Schneidlänge cutting length	P04C
...								
FM0100.030.VR	1.0	0.50	6.0	0.95	55	3.0	1.5	●
FM0100.050.VR	1.0	0.50	6.0	0.95	55	5.0	1.5	●
FM0100.080.VR	1.0	0.50	6.0	0.95	65	8.0	1.5	●
FM0100.100.VR	1.0	0.50	6.0	0.95	65	10.0	1.5	●
FM0100.120.VR	1.0	0.50	6.0	0.95	65	12.0	1.5	●
FM0120.030.VR	1.2	0.60	6.0	1.15	55	3.0	1.6	●
FM0120.060.VR	1.2	0.60	6.0	1.15	55	6.0	1.6	●
FM0120.100.VR	1.2	0.60	6.0	1.15	65	10.0	1.6	●
FM0120.120.VR	1.2	0.60	6.0	1.15	65	12.0	1.6	●
FM0130.040.VR	1.3	0.65	6.0	1.25	55	4.0	1.7	●
FM0130.070.VR	1.3	0.65	6.0	1.25	55	7.0	1.7	●
FM0130.110.VR	1.3	0.65	6.0	1.25	65	11.0	1.7	●
FM0130.120.VR	1.3	0.65	6.0	1.25	65	12.0	1.7	●
FM0130.130.VR	1.3	0.65	6.0	1.25	65	13.0	1.7	●
↳ ...								

Informationen zu **ap max.** und **ae** siehe Technische Hinweise.

Information about **ap max.** and **ae** look at the technical informations.

Bestellbeispiel:
für Sorte P04C:
FM0100.030.VR/P04C

order-example:
grade P04C:
FM0100.030.VR/P04C

FM-LINE

VHM - Mikrofräser

solid carbide micro end mills

Typ FMVR ...

VHM - Mikro - Vollradiusfräser

Fräser - Ø DS \triangleq 0.2 - 3.0 mm

solid carbide micro ball nose end mill

mill - Ø DS \triangleq 0.2 - 3.0 mm

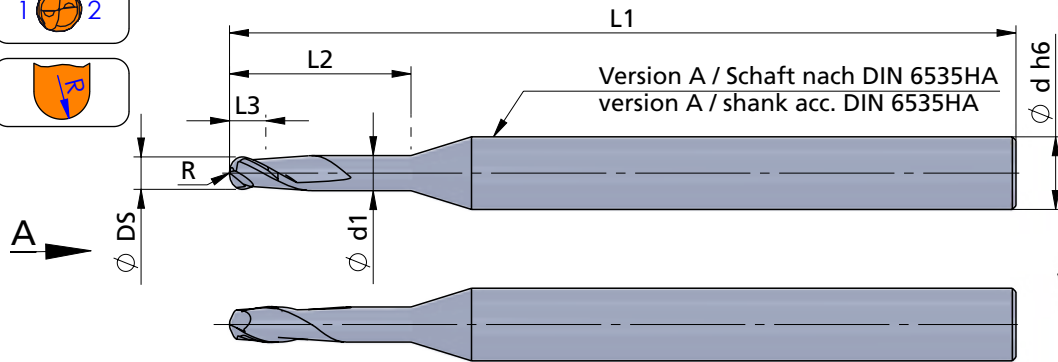
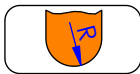
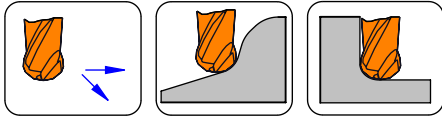

Schneidrichtung (R):
wie gezeichnet

cutting direction (R): as shown

Abmessungen in mm

dimensions in mm

Bestellnummer part number	Ø DS	R	Ø d h6	Ø d1	L1	L2 Bearbeitungslänge processing length	L3 Schneidlänge cutting length	P04C
... ↴								
FM0150.050.VR	1.5	0.75	6.0	1.44	55	5.0	1.8	●
FM0150.075.VR	1.5	0.75	6.0	1.44	55	7.5	1.8	●
FM0150.120.VR	1.5	0.75	6.0	1.44	65	12.0	1.8	●
FM0150.150.VR	1.5	0.75	6.0	1.44	65	15.0	1.8	●
FM0160.050.VR	1.6	0.80	6.0	1.52	55	5.0	1.8	●
FM0160.080.VR	1.6	0.80	6.0	1.52	55	8.0	1.8	●
FM0160.130.VR	1.6	0.80	6.0	1.52	65	13.0	1.8	●
FM0160.160.VR	1.6	0.80	6.0	1.52	65	16.0	1.8	●
FM0180.055.VR	1.8	0.90	6.0	1.72	55	5.5	1.8	●
FM0180.090.VR	1.8	0.90	6.0	1.72	55	9.0	1.8	●
FM0180.145.VR	1.8	0.90	6.0	1.72	65	14.5	1.8	●
FM0180.180.VR	1.8	0.90	6.0	1.72	65	18.0	1.8	●
↳ ...								

Informationen zu **ap max.** und **ae** siehe Technische Hinweise.

Informations about **ap max.** and **ae** look at the technical informations.

order-example:
grade P04C:
FM0150.050.VR/P04C

FM-LINE

VHM - Mikrofräser

solid carbide micro end mills

Typ FMVR ...

VHM - Mikro - Vollradiusfräser

Fräser - Ø DS \triangleq 0.2 - 3.0 mm

solid carbide micro ball nose end mill

mill - Ø DS \triangleq 0.2 - 3.0 mm

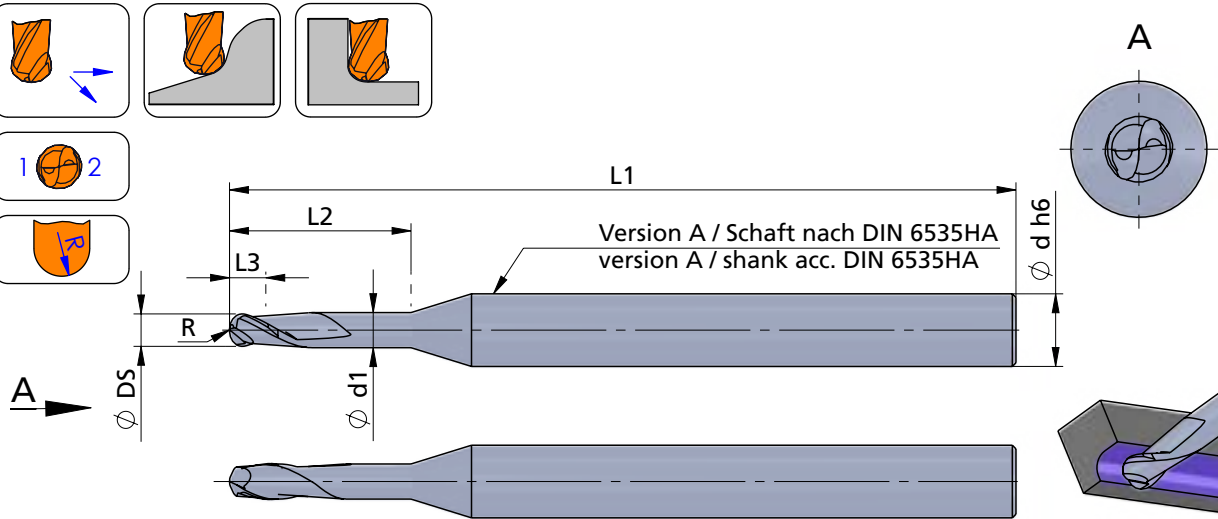
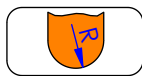
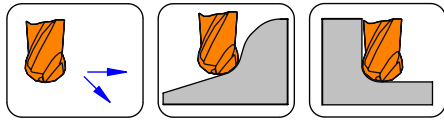

Beispielzeichnung
exemplary application

Schneidrichtung (R):
wie gezeichnet

cutting direction (R): as shown

Abmessungen in mm

dimensions in mm

Bestellnummer part number	Ø DS	R	Ø d h6	Ø d1	L1	L2 Bearbeitungslänge processing length	L3 Schneidenlänge cutting length	P04C
...								
FM0200.060.VR	2.0	1.00	6.0	1.92	55	6.0	2.0	●
FM0200.100.VR	2.0	1.00	6.0	1.92	55	10.0	2.0	●
FM0200.140.VR	2.0	1.00	6.0	1.92	55	14.0	2.0	●
FM0200.160.VR	2.0	1.00	6.0	1.92	65	16.0	2.0	●
FM0200.200.VR	2.0	1.00	6.0	1.92	65	20.0	2.0	●
FM0230.070.VR	2.3	1.15	6.0	2.22	55	7.0	2.3	●
FM0230.115.VR	2.3	1.15	6.0	2.22	55	11.5	2.3	●
FM0230.185.VR	2.3	1.15	6.0	2.22	65	18.5	2.3	●
FM0230.200.VR	2.3	1.15	6.0	2.22	65	20.0	2.3	●
FM0230.230.VR	2.3	1.15	6.0	2.22	65	23.0	2.3	●
FM0300.090.VR	3.0	1.50	6.0	2.90	65	9.0	3.0	●
FM0300.150.VR	3.0	1.50	6.0	2.90	65	15.0	3.0	●
FM0300.240.VR	3.0	1.50	6.0	2.90	100	24.0	3.0	●
FM0300.300.VR	3.0	1.50	6.0	2.90	100	30.0	3.0	●

Informationen zu **ap max.** und **ae** siehe Technische Hinweise.

Informations about **ap max.** and **ae** look at the technical informations.

Bestellbeispiel:
für Sorte P04C:
FM0200.060.VR/P04C

order-example:
grade P04C:
FM0200.060.VR/P04C

FM-LINE

VHM - Mikrofräser

solid carbide micro end mills

Impressionen

impressions



FM-LINE

VHM - Mikrofräser

solid carbide micro end mills

Technische Hinweise

Hartmetallsorten und Beschichtungen

Technical instructions,
carbide grades and coatings

P04C

Optimierte, sehr universell einsetzbare TIALN-Beschichtung mit hoher Temperaturbeständigkeit bei hoher Härte. Sehr gut geeignet auch für NE-Metalle.

Optimized TIALN coating - very universal with a high resistance to high temperature and hardness. Very suitable also for non-ferrous metals.



FM-LINE

VHM - Mikrofräser

solid carbide micro end mills

Technische Hinweise

Schnittdatenempfehlung

Technical instructions,
speed and feed recommendation

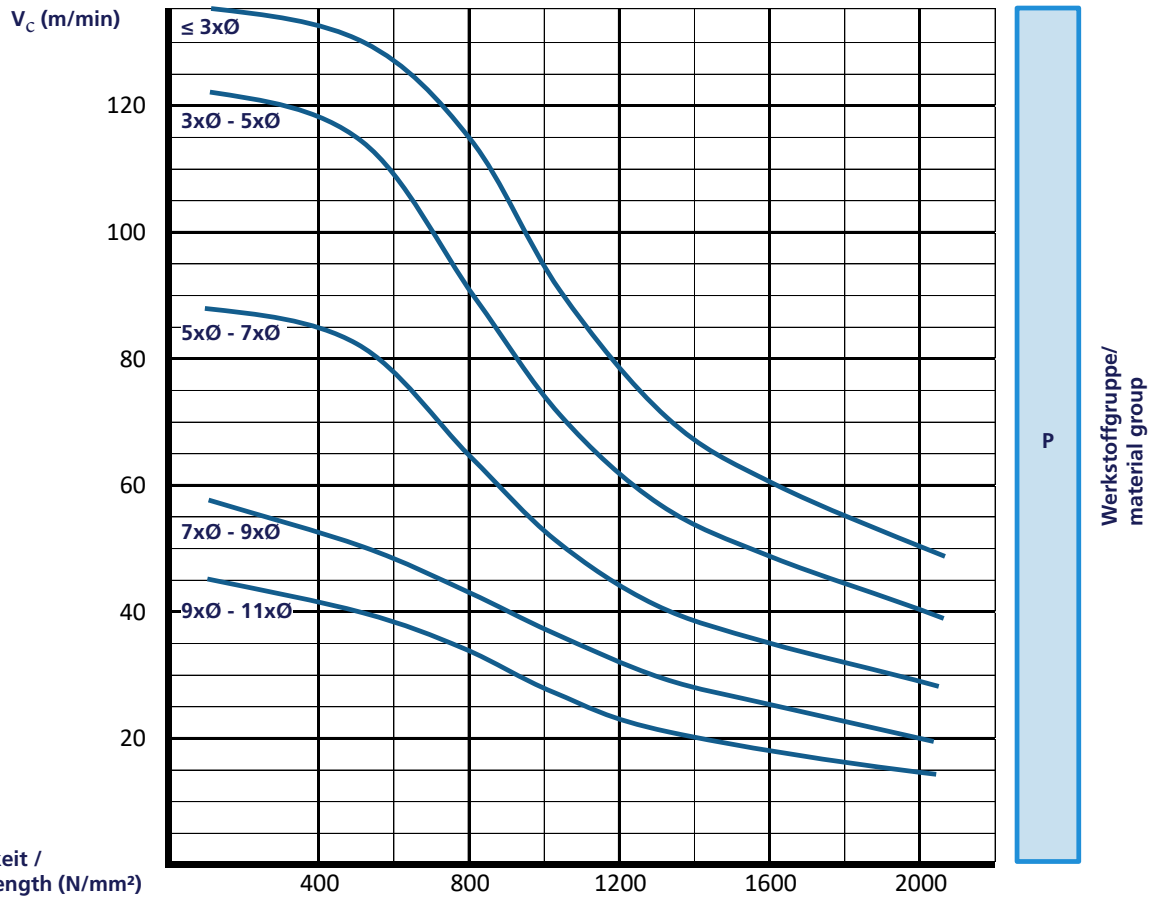

Zugfestigkeit /
tensile strength (N/mm²)

Werkstoffgruppe/
material group

Arbeitseingriff / width of cut	ae :	1x Ø
-----------------------------------	------	------

Länge / length	L2 :	≤ 3x Ø	3x Ø - 5x Ø	5x Ø - 7x Ø	7x Ø - 9x Ø	9x Ø - 11x Ø
Schnitttiefe / depth of cut	ap max. :	0.035x Ø	0.03x Ø	0.025x Ø	0.02x Ø	0.015x Ø

FM-LINE

VHM - Mikrofräser

solid carbide micro end mills

Technische Hinweise

Schnittdatenempfehlung

Technical instructions,
speed and feed recommendation

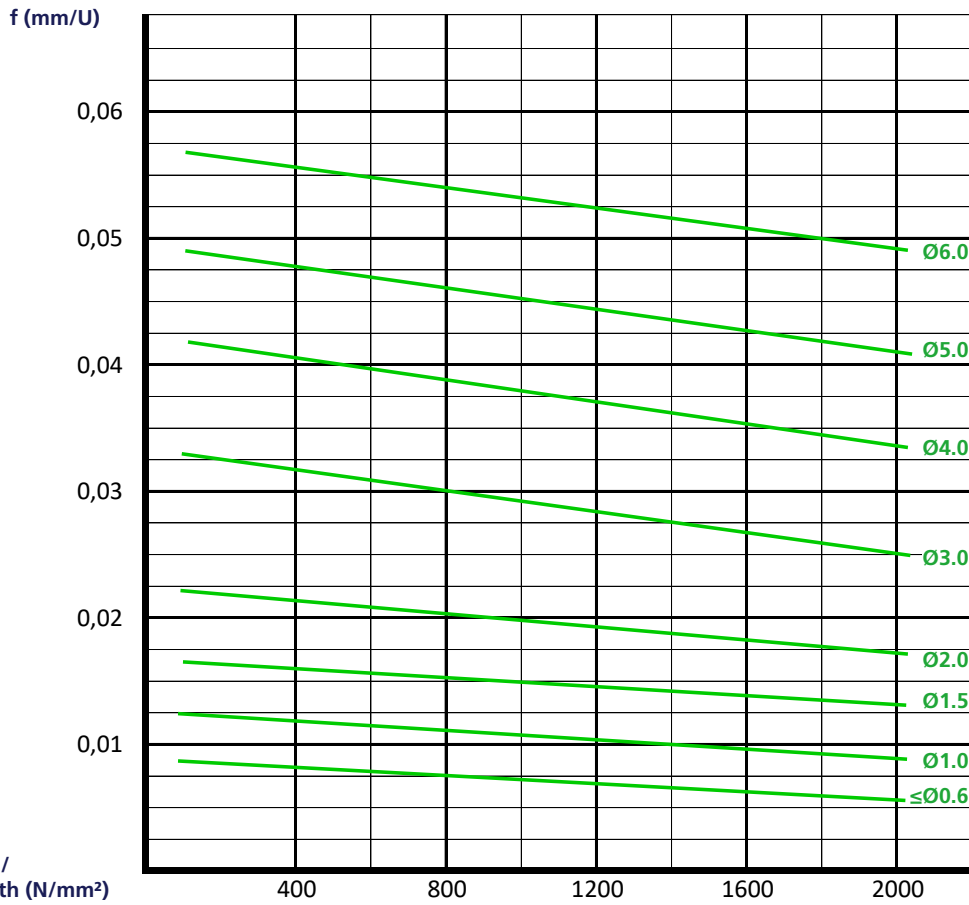



duemmel.de



MIKROMILL

MIKROMILL: D min. $\geq \varnothing 4.0$ mm
Gewinde- $\varnothing \geq 1.0 \times 0,25$ mm
thread- $\varnothing \geq 1.0 \times 0,25$ mm

MIKROMILL XL: DS $\geq \varnothing 12.5$ mm

MIKROMILL

Nut- und Formzirkularfräsen

groove milling
by circular interpolation
and groove milling

Übersicht

summary

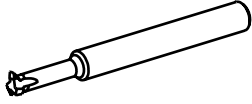

Allgemeine Beschreibung

general instructions

... 5

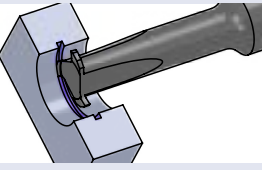

**Schneideinsätze
Nutfräsen**

**inserts
groove milling**

**Maße
dimensions
[mm]**

**Seite
page**

Typ MA6 / MA8

Nutfräsen allgemein

groove milling general use

D min. 6 / 8

... 6

Typ MB6 / MB8

Nutfräsen allgemein

groove milling general use

D min. 6 / 8

... 7

Typ MA6 / MA8 / MA10

Nutfräsen
Vollradius

groove milling
full radius

D min.
4 / 6 / 8 / 10

... 8

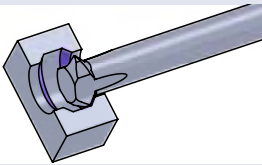

**Schneideinsätze
Vorwärts- und
Rückwärtsfasen**

**inserts
forward and backward
chamfering**

**Maße
dimensions
[mm]**

**Seite
page**

Typ MA6 / MA8

Vorwärts- und Rückwärtsfasen

forward and backward chamfering

D min. 6 / 8

... 9

Typ MB6 / MB8

Vorwärts- und Rückwärtsfasen

forward and backward chamfering

D min. 6 / 8

... 10

MIKROMILL

Nut- und Formzirkularfräsen

groove milling
by circular interpolation
and groove milling

Übersicht

summary

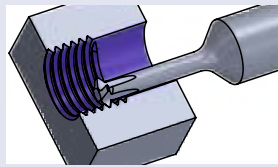

**Schneideinsätze
Gewindefräsen, innen**

**inserts
thread milling, internal**

**Maße
dimensions
[mm]**

**Seite
page**

Typ MA3 / MA5

metrisches ISO-Gewinde,
Teilprofil, innen

metric ISO-thread,
partial profile, internal

Gewinde-/ thread-
 $\text{Ø} \geq 2 \times 0.4$

... 11

**Typ MA3 / MA5 /
MA6 / MA8**

metrisches ISO-Feingewinde,
Teilprofil, innen

metric ISO-fine thread,
partial profile, internal

Gewinde-/ thread-
 $\text{Ø} \geq 1 \times 0.25$

... 12

Typ MB6 / MB8

metrisches ISO-Feingewinde,
Teilprofil, innen

metric ISO-fine thread,
partial profile, internal

Gewinde-/ thread-
 $\text{Ø} \geq 7 \times 0.5$

... 13

Typ MA4 / MA6

metrisches ISO-Gewinde,
Vollprofil, innen

metric ISO-thread,
full profile, internal

Gewinde-/ thread-
 $\text{Ø} \geq 3 \times 0.35$

... 14

Typ MA8 / MA10

metrisches ISO-Gewinde,
Vollprofil, innen

metric ISO-thread,
full profile, internal

Gewinde-/ thread-
 $\text{Ø} \geq 10 \times 0.75$

... 15

Typ MA6 / MA10

Whitworth Rohrgewinde BSP,
Vollprofil, innen

Whitworth pipe thread BSP,
full profile, internal

Gewinde-/ thread-
 $\text{Ø} \geq 1.57$

... 16

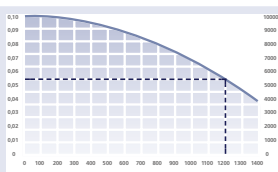

Technische Hinweise

Technical Instructions

**Seite
page**

Grundsätzliche Informationen zum
Gewindefräsen

Basic informations about thread
milling

... 19

Hartmetallsorten und Beschichtungen

carbide grades and coatings

... 22

Ermittlung der Schnittdaten

evaluation of the cutting data

... 24

Schnittdatenempfehlung

speed and feed recommendation

... 26

MIKROMILL XL

T - Nutenfräsen

T - slot milling

Übersicht

summary

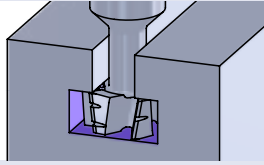

Schneideinsätze
Nutfräsen

inserts
groove milling

Maße
dimensions
[mm]

Seite
page



Typ MA10.TS / MA12.TS
MA16.TS

T - Nutenfräsen

T - slot milling

Ø DS 12.5 - 32
b = 6 - 14

... 17

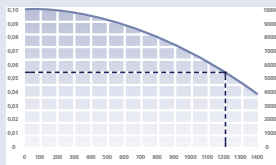

Technische Hinweise

Technical Instructions

Seite
page

Hartmetallsorten und Beschichtungen

carbide grades and coatings

... 22

Ermittlung der Schnittdaten

evaluation of the cutting data

... 24

Schnittdatenempfehlung

speed and feed recommendation

... 26

MIKROMILL

Nut- und Formzirkularfräsen

groove milling
by circular interpolation
and groove milling

Allgemeine Beschreibung

general instruction

Mikromill:

Werkzeuge mit Rundschaft für das Nutfräsen und Fasen ab \varnothing 4 mm und Gewindefräsen ab M1.0 im Standard.

Mikromill:

Tools with round shaft for groove milling and chamfering starting at \varnothing 4 mm and thread machining starting with a thread of M1.0 in standard.

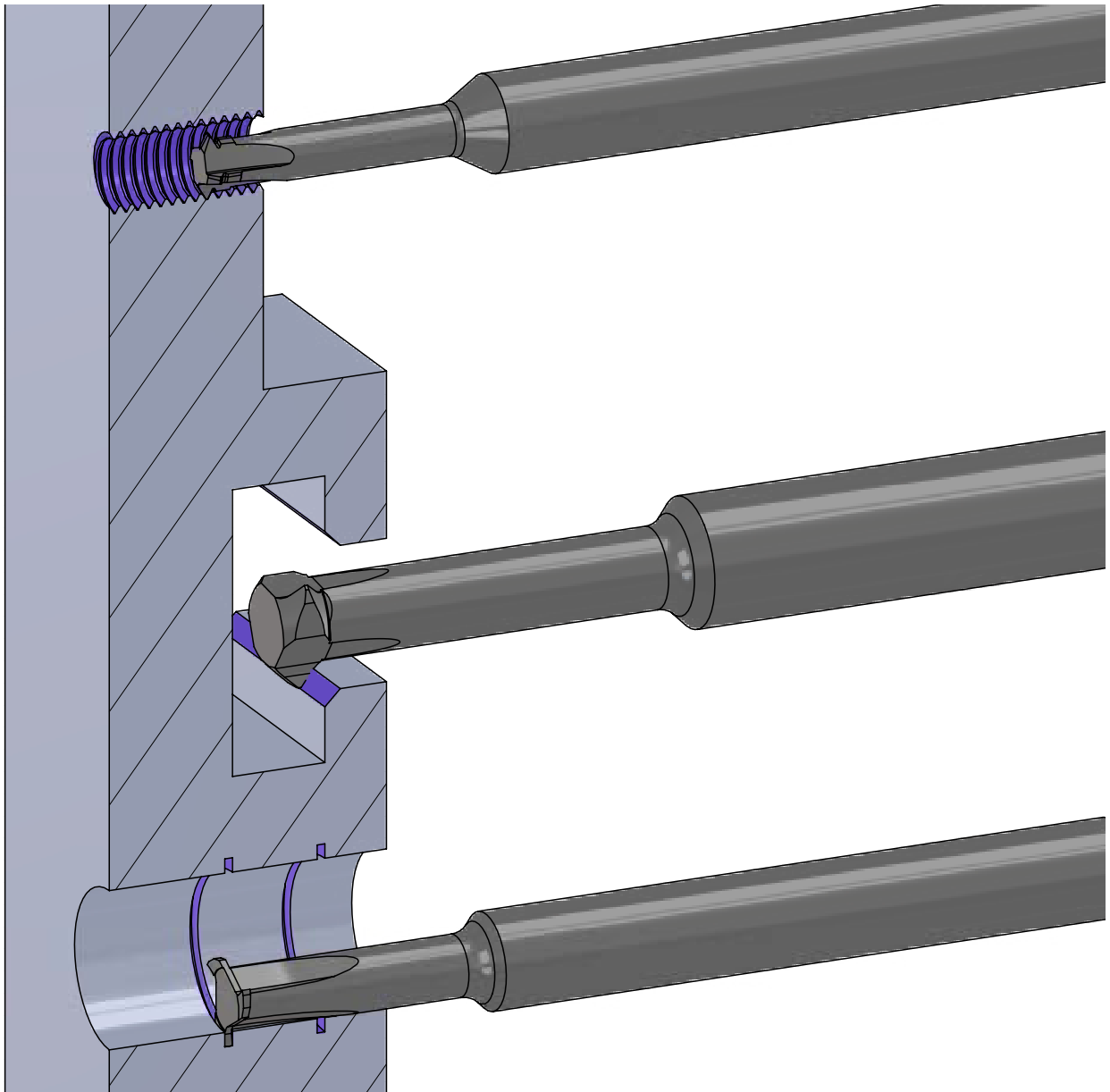

MIKROMILL

Nut- und Formzirkularfräsen

groove milling
by circular interpolation
and groove milling

Typ MA6 / MA8

Nutfräsen allgemein

groove milling general use

D min. 6 / 8 mm

D min. 6 / 8 mm

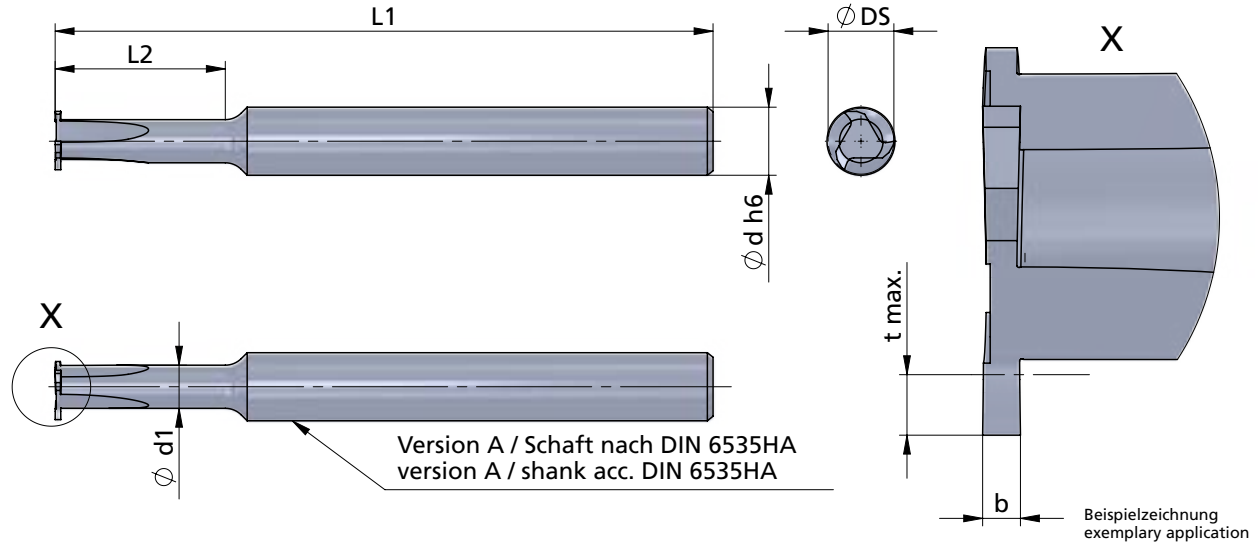

Abmessungen in mm

dimensions in mm

Bestellnummer part number	D min.	b ± 0.02	L2	L1	Ø d h6	Ø d1	Ø DS	t max.	Schneidenzahl cutting edge			
										K10F	AL41F	P18C
MA6.0050.00-15	6	0.5	15	58	6	3.8	5.8	0.8	3		●	
MA6.0060.00-15	6	0.6	15	58	6	3.8	5.8	0.8	3		●	
MA6.0070.00-15	6	0.7	15	58	6	3.8	5.8	0.8	3		●	
MA6.0080.00-15	6	0.8	15	58	6	3.8	5.8	0.8	3		●	
MA6.0090.00-15	6	0.9	15	58	6	3.8	5.8	0.8	3		●	
MA6.0100.00-15	6	1.0	15	58	6	3.8	5.8	0.8	3		●	
MA6.0150.00-15	6	1.5	15	58	6	3.8	5.8	0.8	3		●	
MA8.0070.00-25	8	0.7	25	68	8	5	7.8	1.2	3		●	
MA8.0080.00-25	8	0.8	25	68	8	5	7.8	1.2	3		●	
MA8.0090.00-25	8	0.9	25	68	8	5	7.8	1.2	3		●	
MA8.0100.00-25	8	1.0	25	68	8	5	7.8	1.2	3		●	
MA8.0150.00-25	8	1.5	25	68	8	5	7.8	1.2	3		●	
MA8.0200.00-25	8	2.0	25	68	8	5	7.8	1.2	3		●	

Weitere HM Sorten können Sie in der Sortenübersicht im Kapitel "Technische Hinweise" und der Preisliste finden.

More carbide grades you can find in the grades summary in the chapter "technical instructions" and in the price list.

Bestellbeispiel:
für Sorte AL41F:
MA6.0050.00-15/AL41F

order-example:
grade AL41F:
MA6.0050.00-15/AL41F

MIKROMILL

Nut- und Formzirkularfräsen

groove milling
by circular interpolation
and groove milling

Typ MB6 / MB8

Nutfräsen allgemein

groove milling general use

D min. 6 / 8 mm

D min. 6 / 8 mm

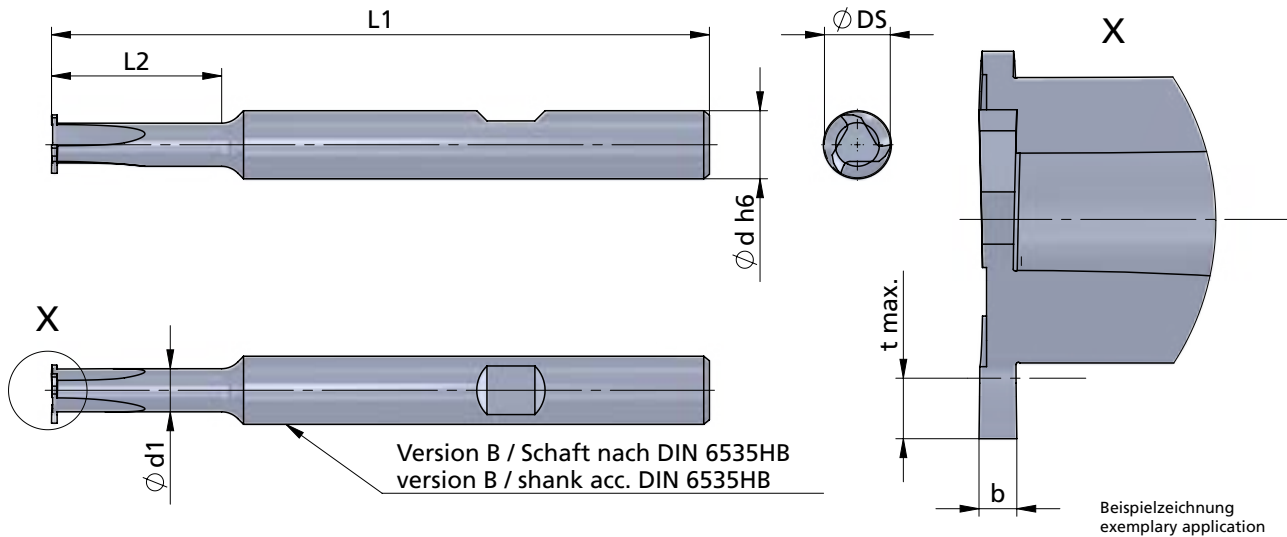

Abmessungen in mm

dimensions in mm

Bestellnummer part number	D min.	b ± 0.02	L2	L1	Ø d h6	Ø d1	Ø DS	t max.	Schneidenzahl cutting edge			
										K10F	AL41F	P18C
MB6.0050.00-15	6	0.5	15	58	6	3.8	5.8	0.8	3	●		
MB6.0060.00-15	6	0.6	15	58	6	3.8	5.8	0.8	3	●		
MB6.0070.00-15	6	0.7	15	58	6	3.8	5.8	0.8	3	●		
MB6.0080.00-15	6	0.8	15	58	6	3.8	5.8	0.8	3	●		
MB6.0090.00-15	6	0.9	15	58	6	3.8	5.8	0.8	3	●		
MB6.0100.00-15	6	1.0	15	58	6	3.8	5.8	0.8	3	●		
MB6.0150.00-15	6	1.5	15	58	6	3.8	5.8	0.8	3	●		
MB8.0070.00-25	8	0.7	25	68	8	5	7.8	1.2	3	●		
MB8.0080.00-25	8	0.8	25	68	8	5	7.8	1.2	3	●		
MB8.0090.00-25	8	0.9	25	68	8	5	7.8	1.2	3	●		
MB8.0100.00-25	8	1.0	25	68	8	5	7.8	1.2	3	●		
MB8.0150.00-25	8	1.5	25	68	8	5	7.8	1.2	3	●		
MB8.0200.00-25	8	2.0	25	68	8	5	7.8	1.2	3	●		

Weitere HM Sorten können Sie in der Sortenübersicht im Kapitel "Technische Hinweise" und der Preisliste finden.

Bestellbeispiel:
für Sorte AL41F:
MB6.0050.00-15/AL41F

More carbide grades you can find in the grades summary in the chapter "technical instructions" and in the price list.

order-example:
grade AL41F:
MB6.0050.00-15/AL41F

MIKROMILL

Nut- und Formzirkularfräsen

groove milling
by circular interpolation
and groove milling

Typ MA6 / MA8 / MA10

Nutfräsen
Vollradius

D min. 4 / 6 / 8 / 10 mm

groove milling
full radius

D min. 4 / 6 / 8 / 10 mm

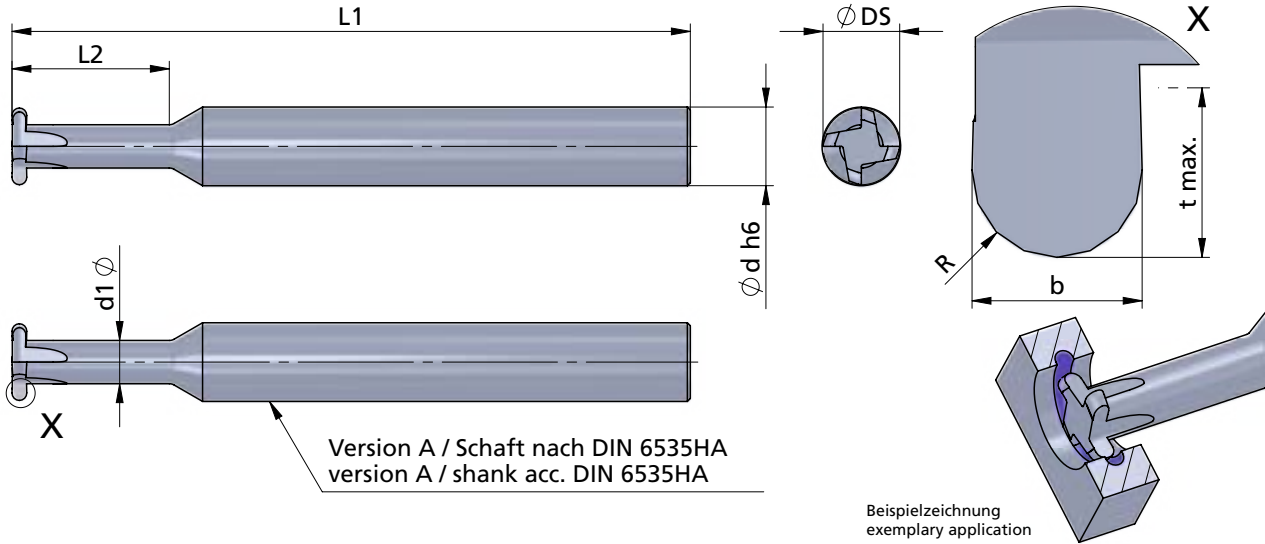

Version A / Schaft nach DIN 6535HA
version A / shank acc. DIN 6535HA

Beispielzeichnung
exemplary application

Abmessungen in mm

dimensions in mm

Bestellnummer part number	Abmessungen in mm / dimensions in mm										Material		
	D min.	b ± 0.02	R	L2	L1	Ø d h6	Ø d1	Ø DS	t max.	Schneidenzahl cutting edge	K10F	AL41F	P18C
MA6.005.10-4	4	1.0	0.5	4	58	6	2.55	3.8	0.5	3			●
MA6.005.10-6	6	1.0	0.5	6	58	6	3.5	5.8	1.0	3			●
MA6.007.15-6	6	1.5	0.75	6	58	6	3.5	5.8	1.0	3			●
MA8.007.15-16	8	1.5	0.75	16	68	8	4.4	7.8	1.5	4			●
MA8.010.20-16	8	2.0	1.0	16	68	8	4.4	7.8	1.5	4			●
MA10.005.10-20	10	1.0	0.5	20	78	10	5.3	9.8	2.0	4			●
MA10.007.15-20	10	1.5	0.75	20	78	10	5.3	9.8	2.0	4			●
MA10.010.20-20	10	2.0	1.0	20	78	10	5.3	9.8	2.0	4			●
MA10.012.25-20	10	2.5	1.25	20	78	10	5.3	9.8	2.0	4			●
MA10.015.30-20	10	3.0	1.5	20	78	10	5.3	9.8	2.0	4			●

Weitere HM Sorten können Sie in der Sortenübersicht im Kapitel "Technische Hinweise" und der Preisliste finden.

More carbide grades you can find in the grades summary in the chapter "technical instructions" and in the price list.

Bestellbeispiel:
für Sorte P18C:
MA6.005.10-4/P18C

order-example:
grade P18C:
MA6.005.10-4/P18C

MIKROMILL

Nut- und Formzirkularfräsen

groove milling
by circular interpolation
and groove milling

Typ MA6 / MA8

Vorwärts- und Rückwärtsfasen

D min. 6 / 8 mm

forward and backward chamfering

D min. 6 / 8 mm

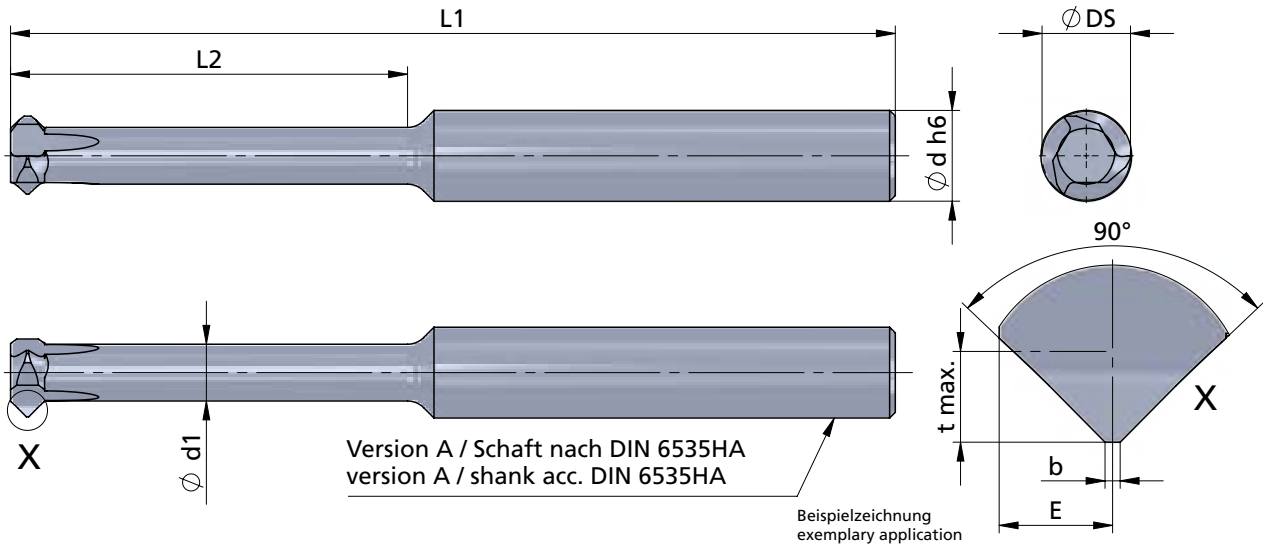

Abmessungen in mm

dimensions in mm

Bestellnummer part number											Schneidenzahl cutting edge	K10F AL41F P18C
	D min.	b	L2	L1	E	Ø d h6	Ø d1	Ø DS	t max.			
MA6.4545.02-15	6	0.2	15	58	1	6	4.2	5.8	0.6	3	●	
MA6.4545.02-25	6	0.2	25	68	1	6	4.2	5.8	0.6	3	●	
MA8.4545.02-25	8	0.2	25	68	1.5	8	5	7.8	1.2	3	●	
MA8.4545.02-35	8	0.2	35	78	1.5	8	5	7.8	1.2	3	●	

Weitere HM Sorten können Sie in der Sortenübersicht im Kapitel "Technische Hinweise" und der Preisliste finden.

Bestellbeispiel:
für Sorte AL41F:
MA6.4545.02-15/AL41F

More carbide grades you can find in the grades summary in the chapter "technical instructions" and in the price list.

order-example:
grade AL41F:
MA6.4545.02-15/AL41F

MIKROMILL

Nut- und Formzirkularfräsen

groove milling
by circular interpolation
and groove milling

Typ MB6 / MB8

Vorwärts- und Rückwärtsfasen

D min. 6 / 8 mm

forward and backward chamfering

D min. 6 / 8 mm

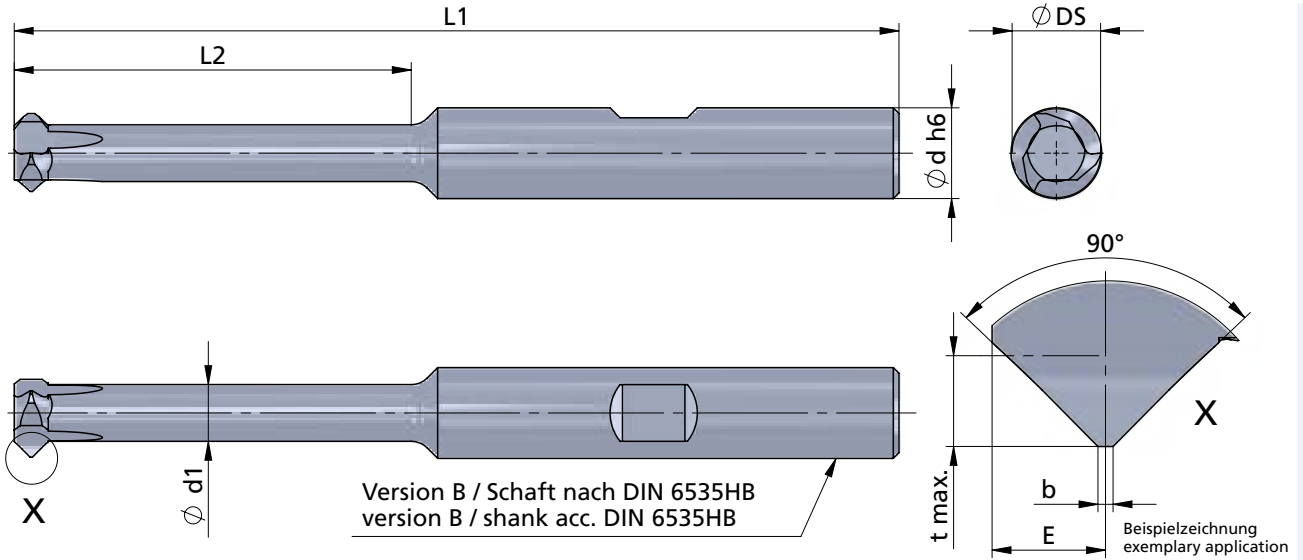

Abmessungen in mm

dimensions in mm

Bestellnummer part number											Schneidenzahl cutting edge	K10F AL41F P18C
	D min.	b	L2	L1	E	Ø d h6	Ø d1	Ø DS	t max.			
MB6.4545.02-15	6	0.2	15	58	1	6	4.2	5.8	0.6	3	●	
MB6.4545.02-25	6	0.2	25	68	1	6	4.2	5.8	0.6	3	●	
MB8.4545.02-25	8	0.2	25	68	1.5	8	5	7.8	1.2	3	●	
MB8.4545.02-35	8	0.2	35	78	1.5	8	5	7.8	1.2	3	●	

Weitere HM Sorten können Sie in der Sortenübersicht im Kapitel "Technische Hinweise" und der Preisliste finden.

Bestellbeispiel:
für Sorte AL41F:
MB6.4545.02-15/AL41F

More carbide grades you can find in the grades summary in the chapter "technical instructions" and in the price list.

order-example:
grade AL41F:
MB6.4545.02-15/AL41F

MIKROMILL

Nut- und Formzirkularfräsen

groove milling
by circular interpolation
and groove milling

Typ MA3 / MA5

metrisches ISO-Gewinde,
Teilprofil, innen

metric ISO-thread,
partial profile, internal

Gewinde- $\emptyset \geq 2 \times 0.4 \text{ mm}$

thread- $\emptyset \geq 2 \times 0.4 \text{ mm}$

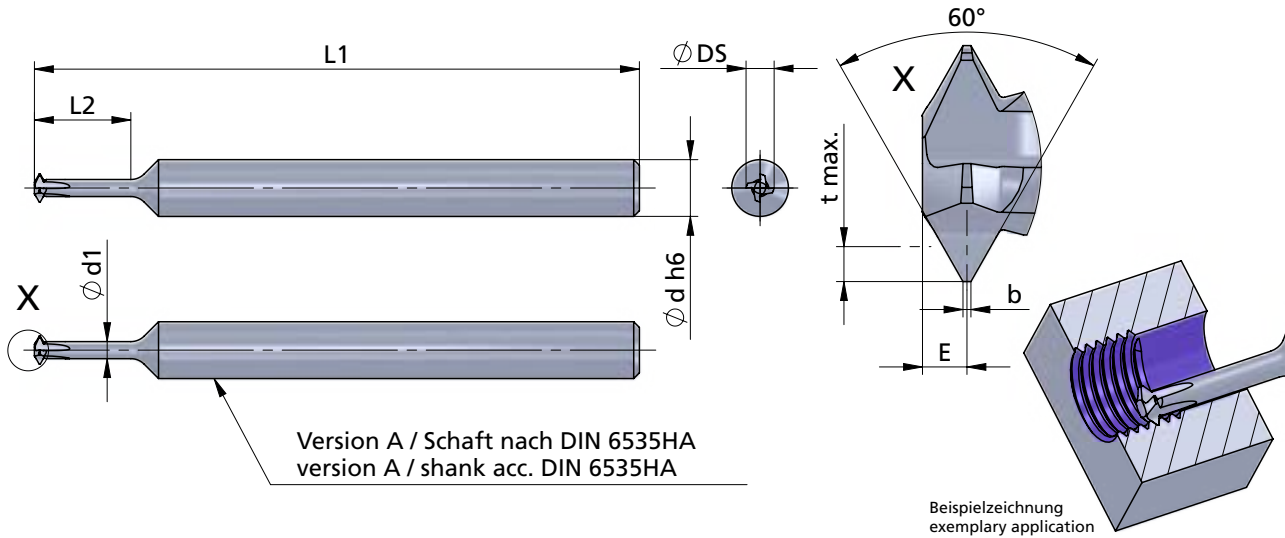

Abmessungen in mm

dimensions in mm

Bestellnummer part number	von Steigung P empfohlen as of pitch P recommended	bis Steigung P möglich up to pitch P possible	min. Gewinde- \emptyset min. thread- \emptyset		L2	L1	b	E	t max.	$\emptyset d h6$	$\emptyset d1$	$\emptyset DS$	Schneidenzahl cutting edge	K10F	AL41F	P18C
MA3.MR20.01-5	0.40	0.45	2.0	5.0	32	0.05	0.3	0.27	3	0.77	1.45	4	●	●	●	
MA3.MR25.01-6	0.45	0.50	2.5	6.0	32	0.05	0.3	0.29	3	1.06	1.80	4	●	●	●	
MA3.MR30.01-7	0.50	0.60	3.0	7.0	32	0.06	0.3	0.35	3	1.27	2.15	4	●	●	●	
MA3.MR35.01-8	0.60	0.70	3.5	8.0	32	0.07	0.4	0.40	3	1.39	2.40	4	●	●	●	
MA5.MR40.01-9	0.70	0.80	4.0	9.0	44	0.08	0.4	0.46	5	1.58	2.70	4	●	●	●	
MA5.MR50.01-10	0.80	1.00	5.0	10.0	44	0.10	0.5	0.59	5	2.14	3.57	4	●	●	●	
MA5.MR60.01-12	1.00	1.25	6.0	12.2	44	0.12	0.6	0.74	5	2.44	4.20	4	●	●	●	
MA5.MR70.01-15	1.00	1.25	7.0	15.2	44	0.12	0.6	0.74	5	3.09	4.90	4	●	●	●	

Weitere HM Sorten können Sie in der Sortenübersicht im Kapitel "Technische Hinweise" und der Preisliste finden.

Bestellbeispiel:
für Sorte AL41F:
MA3.MR20.01-5/AL41F

More carbide grades you can find in the grades summary in the chapter "technical instructions" and in the price list.

order-example:
grade AL41F:
MA3.MR20.01-5/AL41F

MIKROMILL

Nut- und Formzirkularfräsen

groove milling
by circular interpolation
and groove milling

Typ MA3 / MA5 / MA6 / MA8

metrisches ISO-Feingewinde,
Teilprofil, innen

metric ISO-fine thread,
partial profile, internal

Gewinde-Ø ≥ 1 x 0.25 mm

thread-Ø ≥ 1 x 0.25 mm

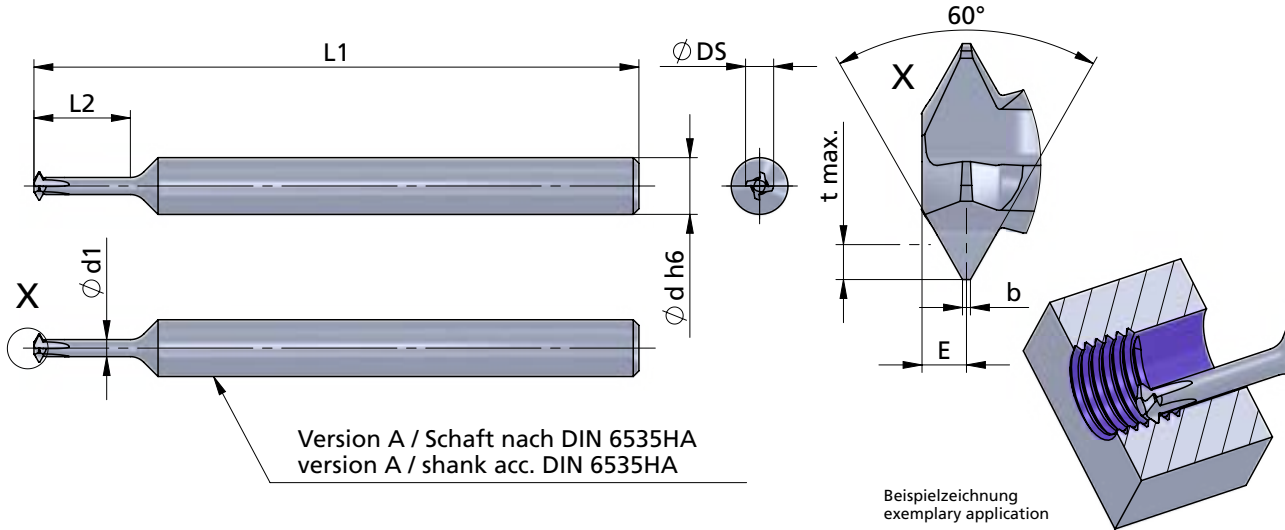

Abmessungen in mm

dimensions in mm

Bestellnummer part number	(von) Steigung P empfohlen (as of) pitch P recommended	(bis) Steigung P möglich (up to) pitch P possible	min. Gewinde-Ø min. thread-Ø * Feingewinde / fine thread	L2	L1	b	E	t max.	Ø d h6	Ø d1	Ø DS	Schneidenzahl cutting edge	K10F	AL41F	P18C
MA3.0025.01-2	0.25	-	1.0	2.5	32	0.03	0.2	0.14	3	0.33	0.70	3	●		
MA3.0035.01-4	0.35	-	1.6	4.0	32	0.04	0.2	0.19	3	0.67	1.18	3	●		
MA3.0035.01-5	0.35	-	1.8	5.0	32	0.04	0.2	0.19	3	0.86	1.38	3	●		
MA3.0040.01-5	0.40	-	2.5*	5.0	32	0.05	0.3	0.22	3	0.92	1.50	4	●		
MA3.0045.01-6	0.45	-	3.0*	6.0	32	0.06	0.3	0.25	3	1.28	1.95	4	●		
MA3.0050.01-7	0.50	-	3.5*	7.0	32	0.06	0.3	0.27	3	1.67	2.40	4	●		
MA3.0060.01-8	0.60	-	4.0*	8.0	32	0.08	0.4	0.33	3	1.93	2.80	4	●		
MA5.0070.01-9	0.70	-	4.5	9.0	44	0.09	0.4	0.38	5	2.12	3.10	4	●		
MA5.0080.01-10	0.80	-	5.5	10.0	44	0.10	0.5	0.43	5	2.97	4.10	4	●		
MA5.0100.01-12	1.00	-	7.0	12.0	44	0.13	0.6	0.54	5	3.51	4.90	4	●		
MA5.0100.01-15	1.00	-	7.0	15.0	44	0.13	0.6	0.54	5	3.50	4.90	4	●		
MA6.0815.01-15	0.50	1.50	7.0	15.0	58	0.06	0.8	0.92	6	3.50	5.80	3	●		
MA8.0815.01-25	0.50	1.50	9.0	25.0	68	0.06	1.0	0.91	8	5.50	7.80	3	●		
MA8.1020.01-25	1.00	2.00	10.0	25.0	68	0.12	1.0	1.19	8	5.00	7.80	3	●		

Weitere HM Sorten können Sie in der Sortenübersicht im Kapitel "Technische Hinweise" und der Preisliste finden.

More carbide grades you can find in the grades summary in the chapter "technical instructions" and in the price list.

Bestellbeispiel:
für Sorte AL41F:
MA3.0025.01-2/AL41F

order-example:
grade AL41F:
MA3.0025.01-2/AL41F

MIKROMILL

Nut- und Formzirkularfräsen

groove milling
by circular interpolation
and groove milling

Typ MB6 / MB8

metrisches ISO-Feingewinde,
Teilprofil, innen

metric ISO-fine thread,
partial profile, internal

Gewinde- $\varnothing \geq 7 \times 0,5 \text{ mm}$

thread- $\varnothing \geq 7 \times 0,5 \text{ mm}$

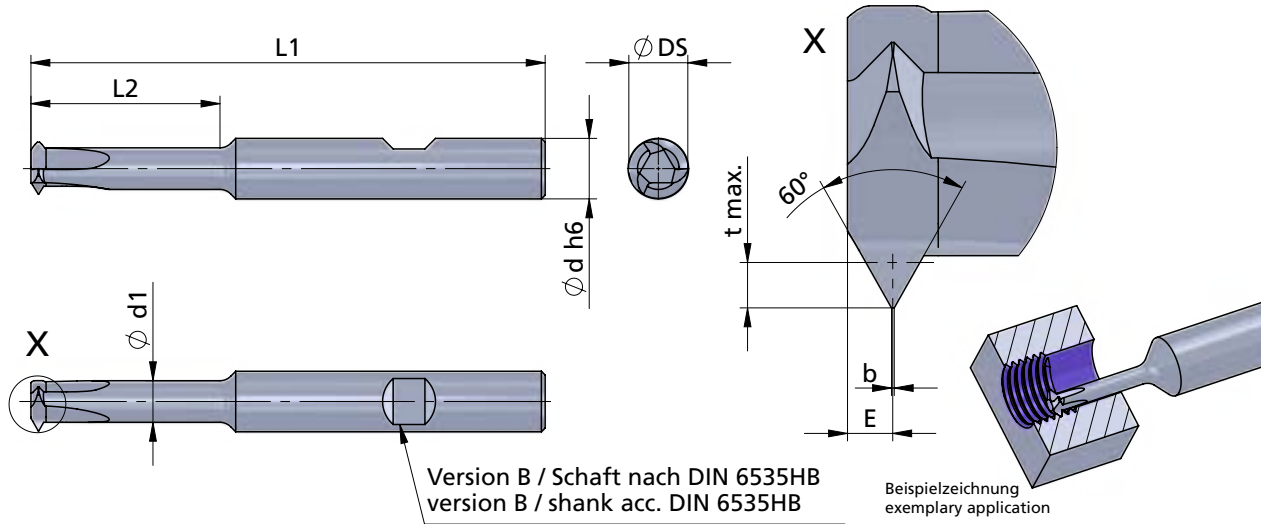

Abmessungen in mm

dimensions in mm

Bestellnummer part number	von Steigung P empfohlen as of pitch P recommended	bis Steigung P möglich up to pitch P possible	min. Gewinde- \varnothing min. thread- \varnothing		L2	L1	b	E	t max.	$\varnothing d h6$	$\varnothing d1$	$\varnothing DS$	Schneidenzahl cutting edge	K10F	AL41F	P18C
MB6.0815.01-15	0.5	1.5	7	15	58	0.06	0.8	0.91	6	3.5	5.8	3	●			
MB8.0815.01-25	0.5	1.5	9	25	68	0.06	1.0	0.91	8	5.5	7.8	3	●			
MB8.1020.01-25	1.0	2.0	10	25	68	0.12	1.0	1.19	8	5.0	7.8	3	●			

Weitere HM Sorten können Sie in der Sortenübersicht im Kapitel "Technische Hinweise" und der Preisliste finden.

Bestellbeispiel:
für Sorte AL41F:
MB6.0815.01-15/AL41F

More carbide grades you can find in the grades summary in the chapter "technical instructions" and in the price list.

order-example:
grade AL41F:
MB6.0815.01-15/AL41F

MIKROMILL

Nut- und Formzirkularfräsen

groove milling
by circular interpolation
and groove milling

Typ MA4 / MA6

metrisches ISO-Gewinde,
Vollprofil, innen

metric ISO-thread,
full profile, internal

Gewinde-Ø ≥ 3 x 0.35 mm

thread-Ø ≥ 3 x 0.35 mm

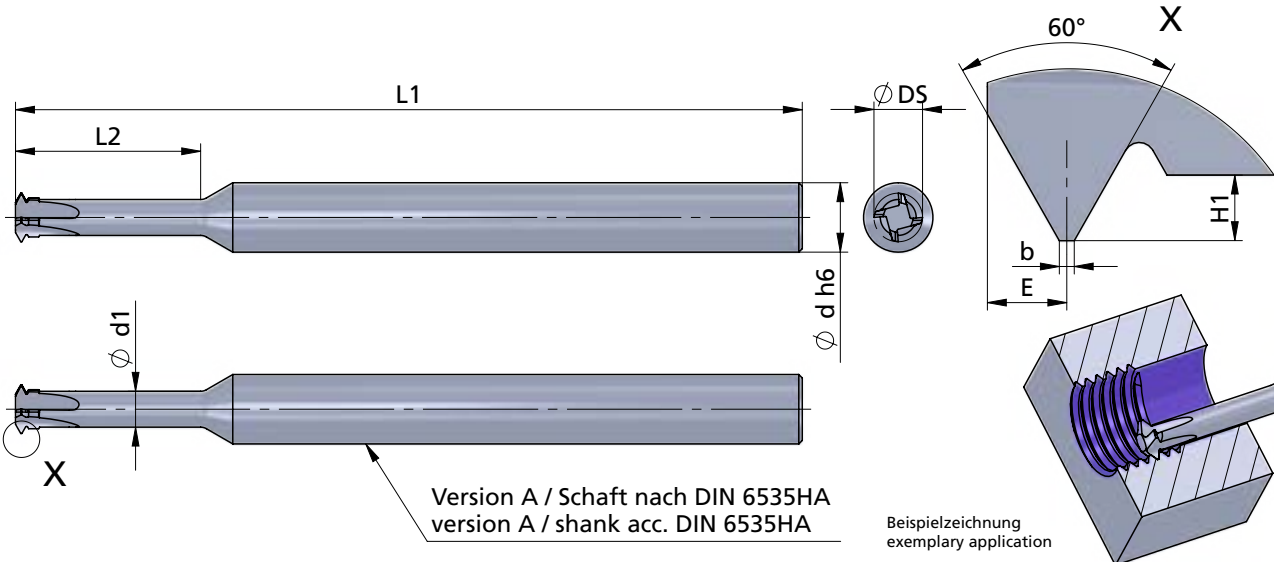

Abmessungen in mm

dimensions in mm

Bestellnummer part number	Steigung P pitch P	min. Gewinde-Ø min. thread Ø * Feingewinde / fine thread	L2	L1	b	E	H1	Ø d h6	Ø d1	Ø DS	Schneidenzahl cutting edge	K10F	AL41F	P18C
MA4.VP035-8	0.35	3.0*	8	44	0.04	0.20	0.19	4	1.40	2.0	3			●
MA4.VP050-8	0.50	3.0	8	44	0.06	0.30	0.27	4	1.25	2.0	3			●
MA4.VP060-9	0.60	3.5	9	44	0.08	0.30	0.33	4	1.40	2.3	3			●
MA6.VP050-10	0.50	4.0*	10	58	0.06	0.30	0.27	6	2.00	2.8	3			●
MA6.VP070-10	0.70	4.0	10	58	0.09	0.40	0.38	6	1.85	2.8	3			●
MA6.VP075-16	0.75	6.0*	16	68	0.10	0.50	0.41	6	3.10	4.2	4			●
MA6.VP080-12	0.80	5.0	12	58	0.09	0.60	0.43	6	2.40	3.6	4			●
MA6.VP100-16	1.00	6.0	16	68	0.12	0.60	0.54	6	2.80	4.2	4			●
MA6.VP125-16	1.25	8.0	16	68	0.16	0.75	0.68	6	3.70	5.5	4			●

Weitere HM Sorten können Sie in der Sortenübersicht im Kapitel "Technische Hinweise" und der Preisliste finden.

Bestellbeispiel:
für Sorte P18C:
MA4.VP035-8/P18C

More carbide grades you can find in the grades summary in the chapter "technical instructions" and in the price list.

order-example:
grade P18C:
MA4.VP035-8/P18C

MIKROMILL

Nut- und Formzirkularfräsen

groove milling
by circular interpolation
and groove milling

Typ MA8 / MA10

metrisches ISO-Gewinde,
Vollprofil, innen

metric ISO-thread,
full profile, internal

Gewinde-Ø ≥ 10 x 0.75 mm

thread-Ø ≥ 10 x 0.75 mm

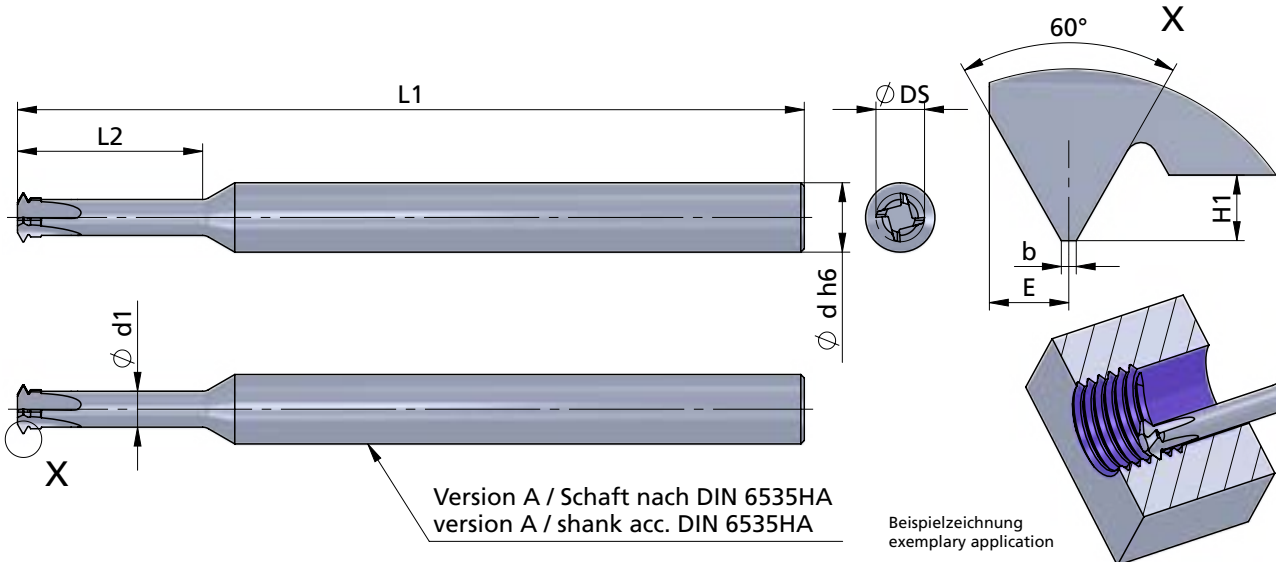

Version A / Schaft nach DIN 6535HA
version A / shank acc. DIN 6535HA

Beispielzeichnung
exemplary application

Abmessungen in mm

dimensions in mm

Bestellnummer part number	Steigung P pitch P	min. Gewinde-Ø min. thread-Ø	L2	L1	b	E	H1	Ø d h6	Ø d1	Ø DS	Schneidenzahl cutting edge			
												K10F	AL41F	P18C
MA8.VP075-20	0.75	10	20	69	0.10	0.5	0.41	8	5.6	6.8	4			●
MA8.VP100-25	1.00	10	25	79	0.12	0.6	0.54	8	5.4	6.8	4			●
MA8.VP150-20	1.50	10	20	69	0.19	1.0	0.81	8	4.7	6.8	4			●
MA10.VP100-20	1.00	12	20	69	0.12	0.6	0.54	10	6.3	8.0	4			●
MA10.VP125-30	1.25	12	30	79	0.16	0.8	0.68	10	6.1	8.0	4			●
MA10.VP175-30	1.75	12	30	79	0.22	1.0	0.95	10	5.5	8.0	4			●

Weitere HM Sorten können Sie in der Sortenübersicht im Kapitel "Technische Hinweise" und der Preisliste finden.

Bestellbeispiel:
für Sorte P18C:
MA8.VP075-20/P18C

More carbide grades you can find in the grades summary in the chapter "technical instructions" and in the price list.

order-example:
grade P18C:
MA8.VP075-20/P18C

MIKROMILL

Nut- und Formzirkularfräsen

groove milling
by circular interpolation
and groove milling

Typ MA6 / MA10

Whitworth Rohrgewinde BSP,
Vollprofil, innen

Whitworth pipe thread BSP,
full profile, internal

Gewinde-Ø ≥ 1.57 mm

thread-Ø ≥ 1.57 mm

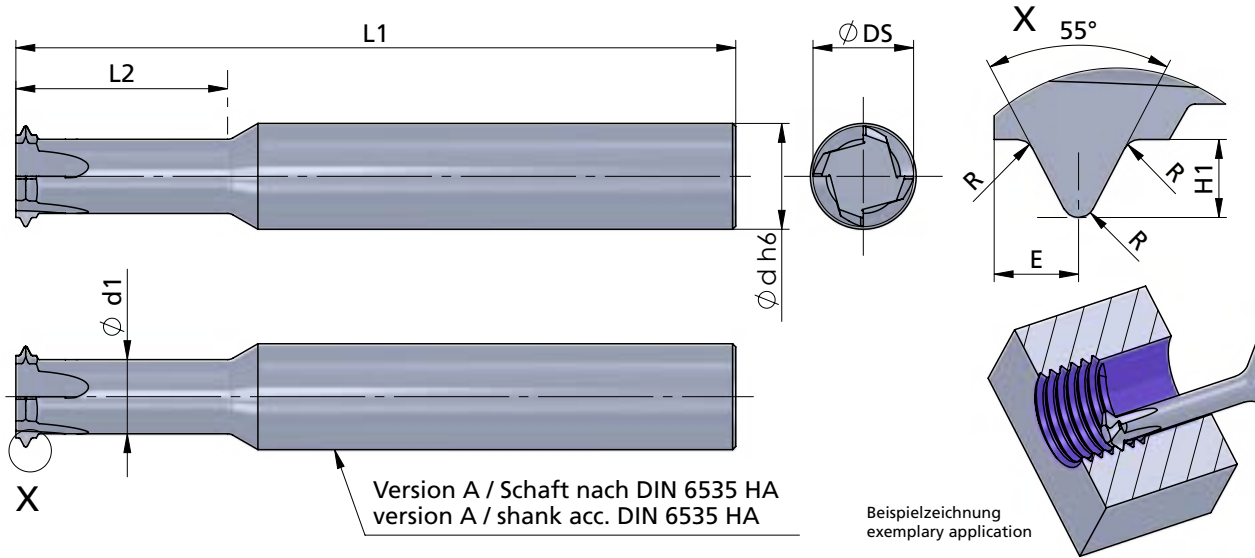

Abmessungen in mm

dimensions in mm

Bestellnummer part number	Gang / Zoll threads / inch	Gewinde-Ø thread-Ø	Gewindegröße thread size	dimensions in mm									Schneidenzahl cutting edge	K10F	AL41F	P18C
				L2	L1	R	E	H1	Ø d h6	Ø d1	Ø DS					
MA6.5528-16	28	1.57 - 3.18	G1/16" - G1/8"	16	68	0.13	0.6	0.58	6	4	5.5	4			●	
MA10.5519-20	19	6.35 - 9.53	G1/4" - G3/8"	20	68	0.18	1.0	0.86	10	7	9.5	4			●	

Weitere HM Sorten können Sie in der Sortenübersicht im Kapitel "Technische Hinweise" und der Preisliste finden.

Bestellbeispiel:
für Sorte P18C:
MA6.5528-16/P18C

More carbide grades you can find in the grades summary in the chapter "technical instructions" and in the price list.

order-example:
grade P18C:
MA6.5528-16/P18C

MIKROMILL XL

T - Nutenfräsen

T - slot milling

Typ MA10.TS / MA12.TS / MA16.TS

T - Nutenfräsen

T - slot milling

Schneidkreis-Ø DS 12.5 - 32 mm
Nutbreite b 6 - 14 mm

cutting edge-Ø DS 12.5 - 32 mm
width of groove b 6 - 14 mm

MA....TS...R : Schruppprofil / roughing profile

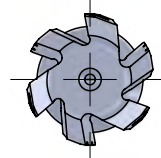
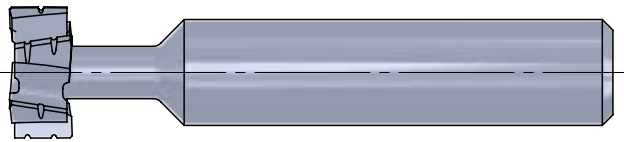

MA....TS...F : Schlichtprofil / finishing profile

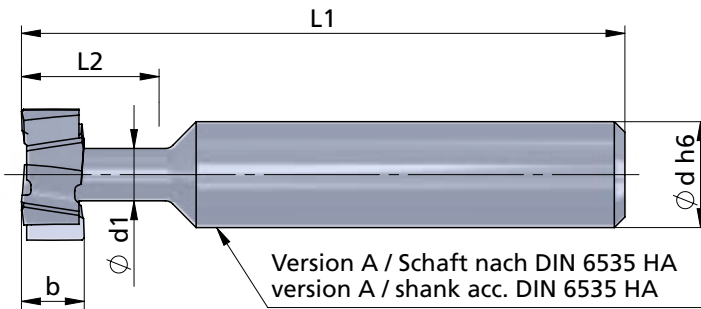

Version A / Schaft nach DIN 6535 HA
version A / shank acc. DIN 6535 HA

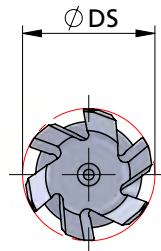

Beispielzeichnung
exemplary application

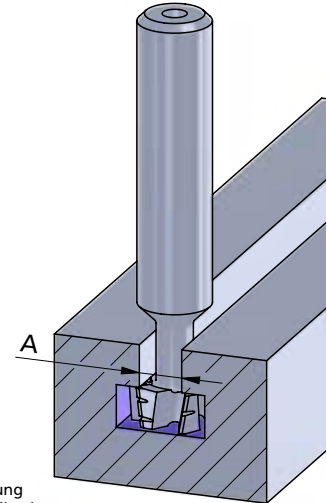

Abmessungen in mm

dimensions in mm

Bestellnummer part number	Schruppprofil roughing profile		Schlichtprofil finishing profile		Material			Schneidzahl cutting edge	Schneidkreis-Ø DS	Nutbreite b	
	b d11	L2	L1	Ø d h6	Ø d1	A	Ø DS d11				K10F
MA10.TS06R-13	6	13	57	10	5	6	12.5	6	●	●	●
MA10.TS08R-16	8	16	62	10	7	8	16	6	●	●	●
MA12.TS08R-18	8	18	70	12	8	10	18	6	●	●	●
MA12.TS09R-21	9	21	74	12	10	12	21	6	●	●	●
MA16.TS11R-25	11	25	82	16	12	14	25	6	●	●	●
MA16.TS12R-28	12	28	85	16	13	(16)	28	6	●	●	●
MA16.TS14R-32	14	32	90	16	15	18	32	6	●	●	●
MA10.TS06F-13	6	13	57	10	5	6	12.5	6	●	●	●
MA10.TS08F-16	8	16	62	10	7	8	16	6	●	●	●
MA12.TS08F-18	8	18	70	12	8	10	18	6	●	●	●
MA12.TS09F-21	9	21	74	12	10	12	21	6	●	●	●
MA16.TS11F-25	11	25	82	16	12	14	25	6	●	●	●
MA16.TS12F-28	12	28	85	16	13	(16)	28	6	●	●	●
MA16.TS14F-32	14	32	90	16	15	18	32	6	●	●	●

Schrupppfräser: max. Leistung, keine Anforderung an Oberfläche
Schlichtfräser: wenn eine Anforderung an die Oberfläche besteht

roughing cutter: max. roughing performance, no requirement on surface quality
finishing cutter: high surface quality

Weitere HM Sorten können Sie in der Sortenübersicht im Kapitel "Technische Hinweise" und der Preisliste finden.

Bestellbeispiel:
für Sorte P18C:
MA10.TS06R-13/P18C

weitere Informationen:

- Nachschleifen ist 2 bis 3 mal möglich, in Abhängigkeit vom Verschleiß.

more informations:

- Regrinding is possible 2 to 3 times depending on wear.

More carbide grades you can find in the grades summary in the chapter "technical instructions" and in the price list.

order-example:
grade P18C:
MA10.TS06R-13/P18C

MIKROMILL

Nut- und Formzirkularfräsen

groove milling
by circular interpolation
and groove milling

Impressionen

impressions

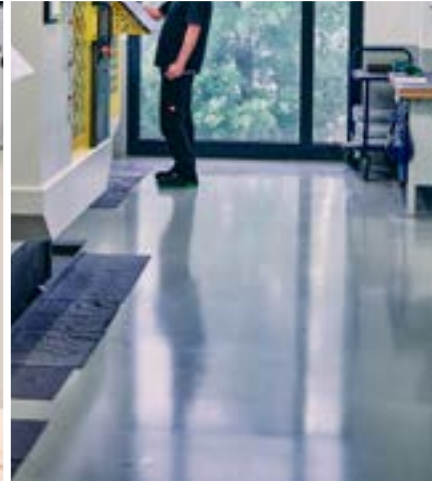
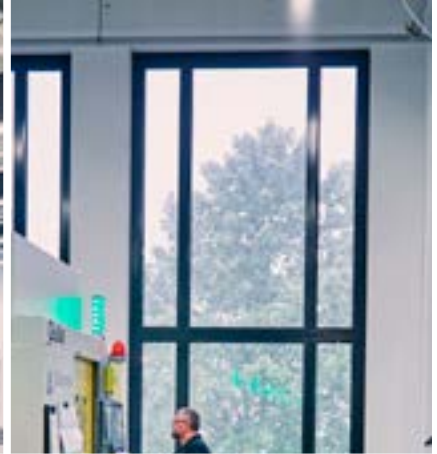

MIKROMILL

Nut- und Formzirkularfräsen

groove milling
by circular interpolation
and groove milling

Technische Hinweise

Grundsätzliche Informationen zum Gewindefräsen

Technical instructions,
basic informations about thread milling

Vor- und Nachschnitt

Beim Zirkularfräsen von Gewinden entsteht durch die Steigung ein Vor- und Nachschnitt. Um hier die Verletzung des Gewindeprofils so gering wie möglich zu halten muß ein Werkzeug mit einem möglichst kleinen Schneidkreis gewählt werden.

Die nachfolgende Skizze zeigt die Verhältnisse bei der Bearbeitung:

(Grün: Konturverletzung X gering = gut; Rot: Konturverletzung X erheblich = schlecht)

Thread profile violation

Thread milling by interpolation causes a profile violation. To keep the violation minimal you should use the cutting circle as small as possible.

The following sketch shows the relations during the process:

(green: profile violation X low = good; red: profile violation X big = bad)

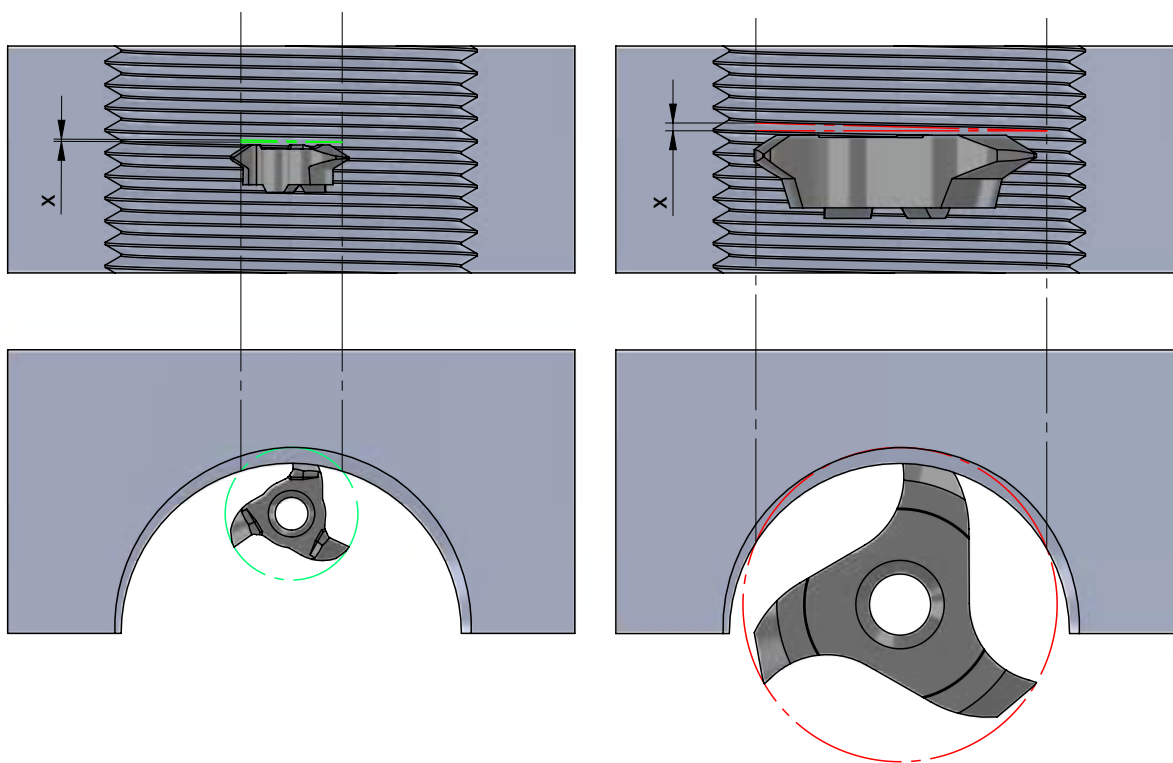

MIKROMILL

Nut- und Formzirkularfräsen

groove milling
by circular interpolation
and groove milling

Technische Hinweise

Grundsätzliche Informationen zum Gewindefräsen

Technical instructions,
basic informations about thread milling

Teilprofil

Werkzeuge mit Teilprofil sind Mehrbereichswerkzeuge, d.h. mit diesem Werkzeug können Gewinde mit unterschiedlichen Steigungen hergestellt werden. Dies ist aber nur mit einer kleinen Abweichung vom Normprofil möglich. Abgestimmt ist das Werkzeug auf die kleinste angegebene Steigung, dieses Profil kann ohne Abweichung produziert werden. Alle weiteren Steigungen können ebenfalls produziert werden, hier weicht aber das gefertigte Profil gegenüber der Norm durch eine höhere Gewindetiefe ab. In der Regel ist dies unproblematisch, muß aber gegebenenfalls im Einzelfall genauer betrachtet werden.

Partial profile

Tools with partial profile are multi-purpose tools, that means you can process several pitches with one tool. The processed shape has a small difference to the standard profile. Created is that tool for the smallest pitch, this profile depends to the standard.

All other pitches are producible, but only with a small deviation. Normally this causes no problem, but sometimes you have to decide case by case.

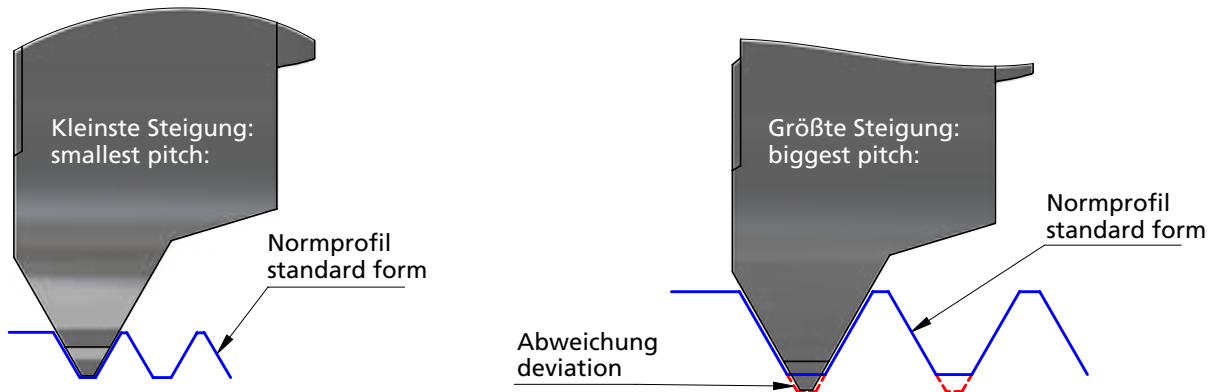

Auswahlhilfe Mehrbereichswerkzeuge

In der nachfolgenden Tabelle sind alle DÜMMEL - Mehrbereichswerkzeuge aufgeführt. Anhand dieser Tabelle können Sie den jeweiligen Einsatzbereich entnehmen (blau= optimale Kontur, grau= mögliche Konturen):

Selection guide multi-purpose-tools

In the following chart are all DÜMMEL - multi-purpose-tools listed. This chart shows the possible area of application (blue= optimal profile; grey= possible profiles):

ab Gewindegröße / starting with thread-size	Steigung (mm)/ pitch (mm)																	
	0,5	0,6	0,7	0,8	0,9	1	1,1	1,2	1,25	1,3	1,4	1,5	1,6	1,7	1,75	1,8	1,9	2
MA/MB 6.0815.01-15	M6,5	M7	M7	M7,5	M8	M8	M8,5	M8,5	M8,5	M8,5	M9	M9						
MA/MB 8.0815.01-25	M8,5	M9	M9,5	M9,5	M10	M10	M10,5	M10,5	M10,5	M11	M11	M11						
MA/MB 8.1020.01-25						M10	M10,5	M10,5	M10,5	M11	M11	M11	M11,5	M11,5	M11,5	M11,5	M11,5	M12

MIKROMILL

Nut- und Formzirkularfräsen

groove milling
by circular interpolation
and groove milling

Technische Hinweise

Grundsätzliche Informationen zum Gewindefräsen

Technical instructions,
basic informations about thread milling

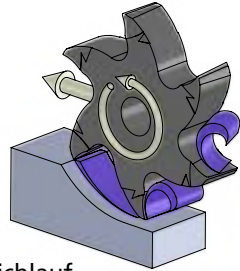

Gleichlauf
down-cut

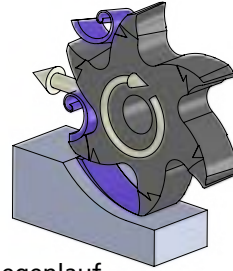

Gegenlauf
up-cut

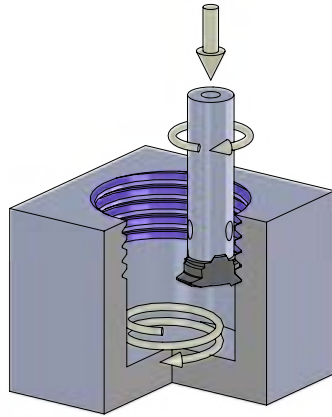

Rechtsgewinde (Gegenlauf)
Linksgewinde (Gleichlauf)*
RH-thread (up-cut)
LH-thread (down-cut)*

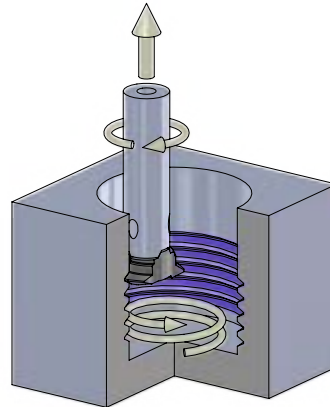

Rechtsgewinde (Gleichlauf)
Linksgewinde (Gegenlauf)*
RH-thread (down-cut)
LH-thread (up-cut)*

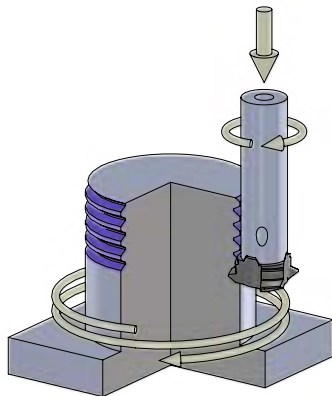

Rechtsgewinde (Gleichlauf)
Linksgewinde (Gegenlauf)*
RH-thread (down-cut)
LH-thread (up-cut)*

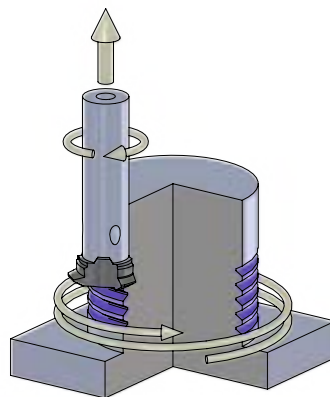

Rechtsgewinde (Gegenlauf)
Linksgewinde (Gleichlauf)*
RH-thread (up-cut)
LH-thread (down-cut)*

*Spiralbewegung axial gespiegelt
*spiral movement axially mirrored



MIKROMILL

Nut- und Formzirkularfräsen

groove milling
by circular interpolation
and groove milling

MIKROMILL XL

T - Nutenfräsen

T - slot milling

Technische Hinweise

Hartmetallsorten und Beschichtungen

Technical instructions,
carbide grades and coatings

K10F

Universell einsetzbares Feinkornhartmetall mit guter Verschleißfestigkeit. Unbeschichtet geeignet für Anwendungen mit niedrigen und mittleren Schnittgeschwindigkeiten, sowie die Bearbeitung von NE-Metallen.

All purpose micrograin carbide with good abrasion resistance. Uncoated for applications with low or medium cutting speeds and machining of non-ferrous materials.

P04C

Optimierte, sehr universell einsetzbare TIALN-Beschichtung mit hoher Temperaturbeständigkeit bei hoher Härte. Sehr gut geeignet auch für NE-Metalle.

Optimized TIALN coating - very universal with a high resistance to high temperature and hardness. Very suitable also for non-ferrous metals.

AL41F

Sehr universell einsetzbare TIALN-Beschichtung mit hoher Temperaturbeständigkeit bei hoher Härte. Sehr gut geeignet auch für NE-Metalle.

TIALN coating - very universal with a high resistance to high temperature and hardness. Very suitable also for non-ferrous metals.

CN45F

Universell einsetzbare PVD-TIN-Beschichtung. Diese Allround-Sorte ist für niedrige und mittlere Schnittgeschwindigkeiten mit Einschränkung bei NE-Metallen.

PVD-TIN coating - all purpose, all around grade is suitable for low and medium cutting speed with restrictions on non-ferrous materials.

P18C

Universell einsetzbare Hochleistungsschicht mit hoher Oxidationsbeständigkeit, Verschleißfestigkeit und Warmhärte.

Very universal high performance coating with high oxidation resistance, wear resistance and hot hardness resistance.

P07C

Beschichtung für die Bearbeitung von Titan, Edelstahl und Molybdän.

Coating to machine titanium, stainless steel and molybdenum.

MIKROMILL

Nut- und Formzirkularfräsen

groove milling
by circular interpolation
and groove milling

MIKROMILL XL

T - Nutenfräsen

T - slot milling

Technische Hinweise

Hartmetallsorten und Beschichtungen

Technical instructions,
carbide grades and coatings

XC2A

Beschichtung mit einer exzellenten Warmhärte, Oxidationsbeständigkeit und thermischen Isolationsfähigkeit. Ideal für Hartzerspanung >60HRC

Coating with excellent hot hardness, high oxidation resistance and thermal insulation capacity. Ideal for hard machining >60 HRC.

P03C

Beschichtung für die Bearbeitung von schwer zerspanbaren Materialien. Sehr gut auch für die Trockenbearbeitung geeignet.

Coating for materials which are difficult to machine. Perfect to use for dry machining.

PD2F

Beschichtung für den universellen Einsatz bei niedrigen und mittleren Schnittgeschwindigkeiten.

Coating for universal use with medium and low speed.

NEME

Beschichtung für die Bearbeitung von Aluminium, Al-Legierungen, NE-Metallen und Kompositwerkstoffen.

Coating for machining aluminium, Al alloys, non-ferrous metals and composite materials.





MIKROMILL

Nut- und Formzirkularfräsen

groove milling
by circular interpolation
and groove milling

MIKROMILL XL

T - Nutenfräsen

T - slot milling

Technische Hinweise

Ermittlung der Schnittdaten

Technical instructions,
evaluation of the cutting data

$$n = \frac{V_c * 1000}{d * \pi} \quad V_{eff} = f_z * z * n \quad f_z = h_m * \sqrt{\frac{d}{a_e}}$$

Fräsen Außenkontur
milling external

$$V_{prog} = \frac{V_{eff} * (D + d)}{D}$$

$$V_{eff} = \frac{D * V_{prog}}{(D + d)}$$

Fräsen Innenkontur
milling internal

$$V_{prog} = \frac{V_{eff} * (D - d)}{D}$$

$$V_{eff} = \frac{D * V_{prog}}{(D - d)}$$

Formel-Zeichen
formula characters

Bezeichnungen
specifications

Einheit
unit

a_e

Spantiefe radial
radial depth of cut

mm

d

Fräserdurchmesser
milling diameter

mm

D

Konturdurchmesser
contour diameter

mm

f_z

Vorschub pro Zahn
feed per tooth

mm

h_m

mittlere Spandicke
medium thickness of chip

mm

h_{max}

maximale Spandicke
maximum thickness of chip

mm

n

Spindeldrehzahl
revolutions

U / min

R

Radius Fräser
radius of cutter

mm

Nach Möglichkeit immer im Kreisbogen eintauchen.

Always plunge in a circular arc where possible.

MIKROMILL

Nut- und Formzirkularfräsen

groove milling
by circular interpolation
and groove milling

MIKROMILL XL

T - Nutenfräsen

T - slot milling

Technische Hinweise

Ermittlung der Schnittdaten

Technical instructions,
evaluation of the cutting data

$$n = \frac{V_c * 1000}{d * \pi}$$

$$V_f = f_z * z * n$$

$$f_z = h_m * \sqrt{\frac{d}{a_e}}$$

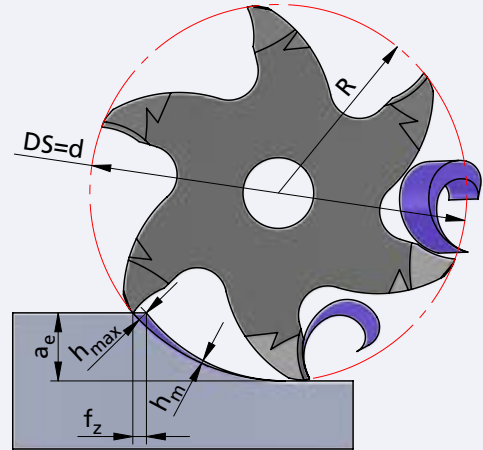

Formel-Zeichen
formula characters

Bezeichnungen
specifications

Einheit
unit

V_{eff}

effektive Vorschubgeschwindigkeit
(auf / an der Kontur)
feed rate of tool tip

mm / min

V_{prog}

programmierte Vorschubgeschwindigkeit
feed rate of tool center

mm / min

V_c

Schnittgeschwindigkeit
cutting speeds

m / min

V_f

Vorschubgeschwindigkeit
feed rate of tool center

mm / min

z

Schneidenzahl Fräser
number of cutting edges

Stk.
pcs.



MIKROMILL

Nut- und Formzirkularfräsen

groove milling
by circular interpolation
and groove milling

MIKROMILL XL

T - Nutenfräsen

T - slot milling

Technische Hinweise

Schnittdatenempfehlung:
metrisch

Technical instructions,
speed and feed recommendation:
metric

Schnittgeschwindigkeit: V_c (m/min)
Vorschub pro Zahn: fz (mm)

cutting speed: V_c (m/min)
feed per tooth: fz (mm)



Werkstoffgruppe material group		Zusammensetzung composition		(Zug-)Festigkeit tensile strength	
ISO	Beschreibung / description	Gefüge / structure	Wärmebehandlung / heat treatment	Psi / N/mm ² (Rm) / HB / HRC	
P	Unlegierter Stahl unalloyed steel	ca.lapp. 0,15 % C	geglüht / annealed	61000 Psi / 420 N/mm ² / 125 HB	
		ca.lapp. 0,45 % C	geglüht / annealed	93000 Psi / 640 N/mm ² / 190 HB	
			vergütet / tempered	122000 Psi / 840 N/mm ² / 250 HB	
		ca.lapp. 0,75 % C	geglüht / annealed	132000 Psi / 910 N/mm ² / 270 HB	
	Niedriglegierter Stahl low alloyed steel		vergütet / tempered	146500 Psi / 1010 N/mm ² / 300 HB	
			geglüht / annealed	88500 Psi / 610 N/mm ² / 180 HB	
			vergütet / tempered	135000 Psi / 930 N/mm ² / 275 HB	
			vergütet / tempered	146500 Psi / 1010 N/mm ² / 300 HB	
	Hochlegierter (Werkzeug)-Stahl highly alloyed steel		geglüht / annealed	174000 Psi / 1200 N/mm ² / 375 HB	
			geglüht / annealed	99000 Psi / 680 N/mm ² / 200 HB	
		gehärtet & angelassen / hardened & tempered	160000 Psi / 1100 N/mm ² / 300 HB		
Nichtrostender Stahl stainless steel		gehärtet & angelassen / hardened & tempered	189000 Psi / 1300 N/mm ² / 400 HB		
		ferritisch, martensitisch / ferritic, martensitic	geglüht / annealed	99000 Psi / 680 N/mm ² / 200 HB	
M	Nichtrostender Stahl stainless steel		martensitisch / martensitic	vergütet / tempered	117500 Psi / 810 N/mm ² / 250 HB
			austenitisch / austenitic	abgeschreckt / quenched	88500 Psi / 610 N/mm ² / 200 HB
			austenitisch / austenitic	vergütet / tempered	300 HB
K	Grauguss cast iron		austenitisch, ferritisch / ferritic, martensitic (Duplex)	113000 Psi / 780 N/mm ² / 230 HB	
			perlitisch, ferritisch / pearlitic, ferritic	51000 Psi / 350 N/mm ² / 180 HB	
	Gusseisen mit Kugelgraphit cast iron with nodular graphite		perlitisch (martensitisch) / pearlitic (martensitic)	72500 Psi / 500 N/mm ² / 260 HB	
			ferritisch / ferritic	72500 Psi / 500 N/mm ² / 160 HB	
Temperguss malleable iron		perlitisch / pearlitic	122500 Psi / 845 N/mm ² / 250 HB		
		ferritisch / ferritic	63800 Psi / 440 N/mm ² / 130 HB		
N	Aluminium - Knetlegierungen wrought aluminum alloys		perlitisch / pearlitic	113000 Psi / 780 N/mm ² / 230 HB	
			nicht aushärtbar / uncurable	60 HB	
			aushärtbar / curable	ausgehärtet / cured	49000 Psi / 340 N/mm ² / 100 HB
	Aluminium - Gusslegierungen cast aluminum alloys		≤ 12% Si, nicht aushärtbar / uncurable	ausgehärtet / cured	36250 Psi / 250 N/mm ² / 75 HB
			≤ 12% Si, aushärtbar / curable	ausgehärtet / cured	43500 Psi / 300 N/mm ² / 90 HB
			> 12% Si, nicht aushärtbar / uncurable	ausgehärtet / cured	63800 Psi / 440 N/mm ² / 130 HB
			PB > 1 %, Automatenlegierungen / free cutting alloys	ausgehärtet / cured	54500 Psi / 375 N/mm ² / 110 HB
Kupfer und Kupferlegierungen (Bronze / Messing) copper and copper alloys (bronze / brass)		CuZn, CuSnZn	ausgehärtet / cured	43500 Psi / 300 N/mm ² / 90 HB	
		CuSn, bleifrei & Elektrolytisch / lead free & electrolytic	ausgehärtet / cured	49000 Psi / 340 N/mm ² / 100 HB	
Magnesium - & Legierungen / Mg-alloys		Magnesium und -Legierungen / and -alloys	ausgehärtet / cured	70 HB	
S	Warmfeste Legierungen heat-resistant alloys		Fe-Basis / Fe base	geglüht / annealed	99000 Psi / 680 N/mm ² / 200 HB
				ausgehärtet / cured	137750 Psi / 950 N/mm ² / 280 HB
			Ni- oder Co-Basis / Ni- or Co-Base	geglüht / annealed	122000 Psi / 840 N/mm ² / 250 HB
				ausgehärtet / cured	171000 Psi / 1180 N/mm ² / 350 HB
	Titanlegierungen titanium alloys			gegossen / cast	156600 Psi / 1080 N/mm ² / 320 HB
			Reintitan / pure titanium	ausgehärtet / cured	58000 Psi / 400 N/mm ²
H	Gehärteter Stahl hardened steel		Alpha- + Beta-Legierungen / -alloys	ausgehärtet / cured	152250 Psi / 1050 N/mm ²
			Beta-Legierungen / -alloys	ausgehärtet / cured	203000 Psi / 1400 N/mm ² / 410 HB
				gehärtet & angelassen / hardened & tempered	46-55 HRC
				gehärtet & angelassen / hardened & tempered	56-60 HRC
	Hartguss / chilled cast iron			gehärtet & angelassen / hardened & tempered	61-65 HRC
Gehärtetes Guss / hardened cast iron			gehärtet & angelassen / hardened & tempered	66-70 HRC	
O	Nichtmetallische Werkstoffe non-metallic materials		gegossen / cast	400 HB	
				gehärtet & angelassen / hardened & tempered	55 HRC
			Kunststoffe, duroplastisch / plastics, duroplastic		≤ 21750 Psi / ≤ 150 N/mm ²
			Kunststoffe, thermoplastisch / plastics, thermoplastic		≤ 14500 Psi / ≤ 100 N/mm ²
			aramidfaserverstärkt / aramid fiber reinforced		≤ 145000 Psi / ≤ 1000 N/mm ²
	glas/kohlefaserverstärkt / glas/carbon fiber reinforced		≤ 145000 Psi / ≤ 1000 N/mm ²		
	Graphit / graphite				

Richtige Schnittgeschwindigkeit ist in Abhängigkeit von Dimension und Anwendungssituation zu wählen.

The correct cutting speed must be selected depending on the dimension and application situation.

20 (10 - 50) bevorzugte Wahl / best choice
20 (10 - 50) bedingt möglich / conditionally possible

20 (10 - 50)
empfohlener Startwert / recommended starting value (bevorzugter Einsatzbereich) / (preferred application area)



MIKROMILL

Nut- und Formzirkularfräsen

groove milling
by circular interpolation
and groove milling

MIKROMILL XL

T - Nutenfräsen

T - slot milling

Technische Hinweise

Schnittdatenempfehlung:

Technical instructions,
speed and feed recommendation:
imperial

cutting speed (SFM):
feed per tooth:

V_C (feet/min)
fz (inch)



Werkstoffgruppe material group		Zusammensetzung composition		(Zug-)Festigkeit tensile strength
ISO	Beschreibung / description	Gefüge / structure	Wärmebehandlung / heat treatment	Psi / N/mm ² (Rm) / HB / HRC
P	Unlegierter Stahl unalloyed steel	ca.lapp. 0,15 % C	geglüht / annealed	61000 Psi / 420 N/mm ² / 125 HB
		ca.lapp. 0,45 % C	geglüht / annealed	93000 Psi / 640 N/mm ² / 190 HB
			vergütet / tempered	122000 Psi / 840 N/mm ² / 250 HB
		ca.lapp. 0,75 % C	geglüht / annealed	132000 Psi / 910 N/mm ² / 270 HB
	Niedriglegierter Stahl low alloyed steel		vergütet / tempered	146500 Psi / 1010 N/mm ² / 300 HB
			geglüht / annealed	88500 Psi / 610 N/mm ² / 180 HB
			vergütet / tempered	135000 Psi / 930 N/mm ² / 275 HB
			vergütet / tempered	146500 Psi / 1010 N/mm ² / 300 HB
	Hochlegierter (Werkzeug)-Stahl highly alloyed steel		vergütet / tempered	174000 Psi / 1200 N/mm ² / 375 HB
			geglüht / annealed	99000 Psi / 680 N/mm ² / 200 HB
Nichtrostender Stahl stainless steel		gehärtet & angelassen / hardened & tempered	160000 Psi / 1100 N/mm ² / 300 HB	
		gehärtet & angelassen / hardened & tempered	189000 Psi / 1300 N/mm ² / 400 HB	
M	Nichtrostender Stahl stainless steel	ferritisch, martensitisch / ferritic, martensitic	geglüht / annealed	99000 Psi / 680 N/mm ² / 200 HB
		martensitisch / martensitic	vergütet / tempered	117500 Psi / 810 N/mm ² / 250 HB
		austenitisch / austenitic	abgeschreckt / quenched	88500 Psi / 610 N/mm ² / 200 HB
K	Grauguss cast iron	austenitisch / austenitic	vergütet / tempered	300 HB
		austenitisch, ferritisch / ferritic, martensitic (Duplex)		113000 Psi / 780 N/mm ² / 230 HB
		perlitisch, ferritisch / pearlitic, ferritic		51000 Psi / 350 N/mm ² / 180 HB
K	Gusseisen mit Kugelgraphit cast iron with nodular graphite	perlitisch (martensitisch) / pearlitic (martensitic)		72500 Psi / 500 N/mm ² / 260 HB
		ferritisch / ferritic		72500 Psi / 500 N/mm ² / 160 HB
	Temperguss malleable iron	perlitisch / pearlitic		122500 Psi / 845 N/mm ² / 250 HB
		ferritisch / ferritic		63800 Psi / 440 N/mm ² / 130 HB
N	Aluminium - Knetlegierungen wrought aluminum alloys	nicht aushärtbar / uncurable		60 HB
		aushärtbar / curable	ausgehärtet / cured	49000 Psi / 340 N/mm ² / 100 HB
	Aluminium - Gusslegierungen cast aluminum alloys	≤ 12% Si, nicht aushärtbar / uncurable		36250 Psi / 250 N/mm ² / 75 HB
		≤ 12% Si, aushärtbar / curable	ausgehärtet / cured	43500 Psi / 300 N/mm ² / 90 HB
		> 12% Si, nicht aushärtbar / uncurable		63800 Psi / 440 N/mm ² / 130 HB
	Kupfer und Kupferlegierungen (Bronze / Messing) copper and copper alloys (bronze / brass)	PB > 1 %, Automatenlegierungen / free cutting alloys		54500 Psi / 375 N/mm ² / 110 HB
CuZn, CuSnZn			43500 Psi / 300 N/mm ² / 90 HB	
S	Magnesium- & -Legierungen / Mg-alloys	CuSn, bleifrei & Elektrolytisch / lead free & electrolytic		49000 Psi / 340 N/mm ² / 100 HB
		Magnesium und -Legierungen / and -alloys		70 HB
S	Warmfeste Legierungen heat-resistant alloys	Fe-Basis / Fe base	geglüht / annealed	99000 Psi / 680 N/mm ² / 200 HB
			ausgehärtet / cured	137750 Psi / 950 N/mm ² / 280 HB
		Ni- oder Co-Basis / Ni- or Co-Base	geglüht / annealed	122000 Psi / 840 N/mm ² / 250 HB
			ausgehärtet / cured	171000 Psi / 1180 N/mm ² / 350 HB
	Titanlegierungen titanium alloys	gegossen / cast		156600 Psi / 1080 N/mm ² / 320 HB
		Reintitan / pure titanium		58000 Psi / 400 N/mm ²
H	Gehärteter Stahl hardened steel	Alpha- + Beta-Legierungen / -alloys	ausgehärtet / cured	152250 Psi / 1050 N/mm ²
		Beta-Legierungen / -alloys		203000 Psi / 1400 N/mm ² / 410 HB
	Hartguss / chilled cast iron		gehärtet & angelassen / hardened & tempered	46-55 HRC
			gehärtet & angelassen / hardened & tempered	56-60 HRC
O	Gehärtetes Guss / hardened cast iron		gehärtet & angelassen / hardened & tempered	61-65 HRC
			gehärtet & angelassen / hardened & tempered	66-70 HRC
O	Nichtmetallische Werkstoffe non-metallic materials	gegossen / cast		400 HB
			gehärtet & angelassen / hardened & tempered	55 HRC
		Kunststoffe, duroplastisch / plastics, duroplastic		≤ 21750 Psi / ≤ 150 N/mm ²
		Kunststoffe, thermoplastisch / plastics, thermoplastic		≤ 14500 Psi / ≤ 100 N/mm ²
		aramidfaserverstärkt / aramid fiber reinforced		≤ 145000 Psi / ≤ 1000 N/mm ²
O	glas/kohlefaserverstärkt / glas/carbon fiber reinforced			≤ 145000 Psi / ≤ 1000 N/mm ²
		Graphit / graphite		

The correct cutting speed must be selected depending on the dimension and application situation.

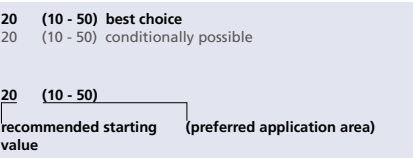



duemmel.de



MINIMILL

MINIMILL: D min. \geq \varnothing 7.0 mm

MINIMILL XL: DS = \varnothing 50 mm

MINIMILL

Nut-, Formzirkular- und
Trennfräsen

groove milling by
circular interpolation,
groove and slot milling

Übersicht

summary



Allgemeine Beschreibung

general instructions

... 11

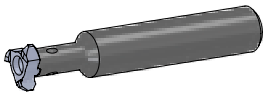

Frälerschaft

milling shank

**Maße
dimensions
[mm]**

**Seite
page**

Typ ZH8	Frälerschaft Stahl	milling shank steel	D min. 7	... 12
Typ ZH8	Frälerschaft Hartmetall	milling shank carbide	D min. 7	... 13
Typ ZH10	Frälerschaft Stahl	milling shank steel	D min. 10	... 14
Typ ZH10	Frälerschaft Hartmetall	milling shank carbide	D min. 10	... 15
Typ ZH10.ER	Frälerschaft, für Spannzangenfutter (DIN 6499)	milling shank, for collet chucks (DIN 6499)	D min. 10	... 16
Typ ZH14	Frälerschaft Stahl	milling shank steel	D min. 14	... 17
Typ ZH14	Frälerschaft Hartmetall	milling shank carbide	D min. 14	... 18
Typ ZH14.ER	Frälerschaft, für Spannzangenfutter (DIN 6499)	milling shank, for collet chucks (DIN 6499)	D min. 14	... 19
Typ ZH18	Frälerschaft Stahl	milling shank steel	D min. 18	... 20
Typ ZH18	Frälerschaft Hartmetall	milling shank carbide	D min. 18	... 21
Typ ZH18.ER	Frälerschaft, für Spannzangenfutter (DIN 6499)	milling shank, for collet chucks (DIN 6499)	D min. 18	... 22

↳ ...

MINIMILL

Nut-, Formzirkular- und
Trennfräsen

groove milling by
circular interpolation,
groove and slot milling

Übersicht

summary

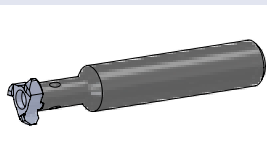

Frälerschaft

milling shank

**Maße
dimensions
[mm]**

**Seite
page**

... ↴

Typ ZH22	Frälerschaft Stahl	milling shank steel	D min. 22	... 23
Typ ZH22	Frälerschaft Hartmetall	milling shank carbide	D min. 22	... 24
Typ ZH22.ER	Frälerschaft, für Spannzangenfutter (DIN 6499)	milling shank, for collet chucks (DIN 6499)	D min. 22	... 25
Typ ZH28	Frälerschaft Stahl	milling shank steel	D min. 25	... 26
Typ ZH28	Frälerschaft Hartmetall	milling shank carbide	D min. 25	... 27
Typ ZH28	Frälerschaft Schwermetall	milling shank heavy metal	D min. 28	... 28
Typ ZH28.ER	Frälerschaft, für Spannzangenfutter (DIN 6499)	milling shank, for collet chucks (DIN 6499)	D min. 25	... 29
Typ ZH33	Frälerschaft Stahl und Hartmetall	milling shank steel and carbide	D min. 28	... 30



MINIMILL

Nut-, Formzirkular- und Trennfräsen

groove milling by circular interpolation, groove and slot milling

Übersicht

summary

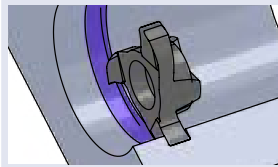

**Schneideinsatz
Nutfräsen**

**inserts
groove milling**

**Maße
dimensions
[mm]**

**Seite
page**

Typ Z8	Sicherungsringe DIN 471/472	for circlips DIN 471/472,	D min. 7 t max. = 0.6	... 32
Typ Z8	Nut- und Trennfräsen	groove and slot milling	D min. 7 - 11 t max. = 0.6 - 2.6	... 33
Typ Z10	Sicherungsringe DIN 471/472 und Nutfräsen allgemein	for circlips DIN 471/472, groove milling general use	D min. 10 t max. = 1.5	... 34
Typ Z12	Sicherungsringe DIN 471/472 und Nutfräsen allgemein	for circlips DIN 471/472, groove milling general use	D min. 12 t max. = 2.5	... 35
Typ Z612 / Z612.X	Nutfräsen allgemein	groove milling general use	D min. 12 t max. = 2	... 36
Typ Z14	Nutfräsen allgemein	groove milling general use	D min. 14 t max. = 2.5	... 37
Typ Z16	Nutfräsen allgemein	groove milling general use	D min. 16 t max. = 3.5	... 38
Typ Z616 / Z616.X	Nutfräsen allgemein	groove milling general use	D min. 16 t max. = 3.5	... 39
Typ Z18	Sicherungsringe DIN 471/472 und Nutfräsen allgemein	for circlips DIN 471/472, groove milling general use	D min. 18 t max. ≤ 3.5	... 40
Typ Z618	Sicherungsringe DIN 471/472	for circlips DIN 471/472	D min. 18 t max. = 4	... 42
Typ Z618 / Z618.X / Z620 / Z620.X	Nutfräsen allgemein	groove milling general use	D min. 18 / 20 t max. = 4 / 5	... 43
Typ Z22	Sicherungsringe DIN 471/472 und Nutfräsen allgemein	for circlips DIN 471/472, groove milling general use	D min. 22 t max. ≤ 4.5	... 44
Typ Z22	Sicherungsringe DIN 471/472 mit Nutaußenkantenfasung	for circlips DIN 471/472 with chamfer	D min. 22	... 46
Typ Z622 / Z622.X	Nutfräsen allgemein	groove milling general use	D min. 22 t max. = 4.5	... 47
Typ Z922	Nutfräsen allgemein	groove milling general use	∅ DS 22 t max. = 4.5	... 48
Typ Z25	Nutfräsen allgemein	groove milling general use	D min. 25 t max. = 5.0	... 49

↳ ...

MINIMILL

Nut-, Formzirkular- und Trennfräsen

groove milling by circular interpolation, groove and slot milling

Übersicht

summary

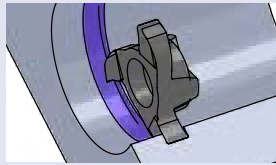

**Schneideinsatz
Nutfräsen**

**inserts
groove milling**

**Maße
dimensions
[mm]**

**Seite
page**

... ↴

Typ Z625.X	Nutfräsen allgemein	groove milling general use	D min. 25 t max. = 5.0	... 50
Typ Z28	Nutfräsen allgemein	groove milling general use	D min. 28 t max. = 6.5	... 51
Typ Z28	Nutfräsen allgemein	groove milling general use	D min. 28.3 t max. = 9.3	... 52
Typ Z628 / Z628.X	Sicherungsringe DIN 471/472 und Nutfräsen allgemein	for circlips DIN 471/472, groove milling general use	D min. 28 t max. = 6.5	... 53
Typ Z628	Nutfräsen allgemein	groove milling general use	D min. 28.3 t max. = 9.3	... 54
Typ Z928	Nutfräsen allgemein	groove milling general use	Ø DS. 28 t max. = 6.5	... 55
Typ Z32	Nutfräsen allgemein	groove milling general use	D min. 32 t max. = 8.5	... 56
Typ Z33	Nutfräsen allgemein	groove milling general use	D min. 33 / 33.9 t max. = 10 / 12	... 57
Typ Z635 / Z635.X	Nutfräsen allgemein	groove milling general use	D min. 35 t max. = 10	... 58
Typ Z637 / Z637.X / Z640	Nutfräsen allgemein	groove milling general use	D min. 37 / 40 t max. = 12 / 13.5	... 59
Typ Z637 / Z640	Nut- und Trennfräsen b = 0.4 - 0.8 mm	groove and slot milling b = 0.4 - 0.8 mm	D min. 37 / 40 t max. = 12 / 13.5	... 60
Typ Z635 / Z637 / Z640	Trennfräsen b = 1.0 / 1.5 mm	slot milling b = 1.0 / 1.5 mm	Schneidkreis-Ø DS 34.7 / 36.7 / 39.7 t max. = 10 / 12 / 13.5	... 61
Typ Z12	Vollradius	full radius	D min. 12 t max. = 2.5	... 62
Typ Z16	Vollradius	full radius	D min. 16 t max. = 3.5	... 63
Typ Z18	Vollradius	full radius	D min. 18 t max. = 3.5	... 64
Typ Z22	Vollradius	full radius	D min. 22 t max. = 4.5	... 65



MINIMILL

Nut-, Formzirkular- und Trennfräsen

groove milling by circular interpolation, groove and slot milling

Übersicht

summary

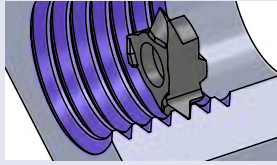

Schneideinsatz Gewindefräsen

inserts thread milling

Maße dimensions [mm]

Seite page

Typ Z8	metrisches ISO-Gewinde, Teilprofil, innen	metric ISO-thread, partial profile, internal	Gewinde-/ thread- Ø ≥ 10 x 0.4	... 67
Typ Z8	metrisches ISO-Gewinde, Vollprofil, innen	metric ISO-thread, full profile, internal	Gewinde-/ thread- Ø ≥ 8 x 0.4	... 68
Typ Z610	metrisches ISO-Gewinde, Teilprofil, innen	metric ISO-thread, partial profile, internal	Gewinde-/ thread- Ø ≥ 12 x 1.0	... 69
Typ Z10	metrisches ISO-Gewinde, Vollprofil, innen	metric ISO-thread, full profile, internal	Gewinde-/ thread- Ø ≥ 12 x 0.75	... 70
Typ Z12	metrisches ISO-Gewinde, Teilprofil, innen	metric ISO-thread, partial profile, internal	Gewinde-/ thread- Ø ≥ 14 x 1.0	... 71
Typ Z614	metrisches ISO-Gewinde, Teilprofil, innen	metric ISO-thread, partial profile, internal	Gewinde-/ thread- Ø ≥ 16 x 1.0	... 72
Typ Z14	metrisches ISO-Gewinde, Vollprofil, innen	metric ISO-thread, full profile, internal	Gewinde-/ thread- Ø ≥ 16 x 1.0	... 73
Typ Z16	metrisches ISO-Gewinde, Teilprofil, innen	metric ISO-thread, partial profile, internal	Gewinde-/ thread- Ø ≥ 18 x 1.0	... 74
Typ Z18	metrisches ISO-Gewinde, Teilprofil, innen	metric ISO-thread, partial profile, internal	Gewinde-/ thread- Ø ≥ 22 x 1.0	... 75
Typ Z618	metrisches ISO-Gewinde, Teilprofil, innen	metric ISO-thread, partial profile, internal	Gewinde-/ thread- Ø ≥ 22 x 1.0	... 76
Typ Z18	metrisches ISO-Gewinde, Vollprofil, innen	metric ISO-thread, full profile, internal	Gewinde-/ thread- Ø ≥ 22 x 1.5	... 77
Typ Z618	metrisches ISO-Gewinde, Vollprofil, innen	metric ISO-thread, full profile, internal	Gewinde-/ thread- Ø ≥ 22 x 1.5	... 78
Typ Z22	metrisches ISO-Gewinde, Teilprofil, innen	metric ISO-thread, partial profile, internal	Gewinde-/ thread- Ø ≥ 27 x 1.0	... 79
Typ Z622	metrisches ISO-Gewinde, Teilprofil, innen	metric ISO-thread, partial profile, internal	Gewinde-/ thread- Ø ≥ 27 x 1.0	... 80
Typ Z22	metrisches ISO-Gewinde, Vollprofil, innen	metric ISO-thread, full profile, internal	Gewinde-/ thread- Ø ≥ 24 x 1.5	... 81
Typ Z622	metrisches ISO-Gewinde, Vollprofil, innen	metric ISO-thread, full profile, internal	Gewinde-/ thread- Ø ≥ 24 x 1.5	... 82

↳ ...

MINIMILL

Nut-, Formzirkular- und
Trennfräsen

groove milling by
circular interpolation,
groove and slot milling

Übersicht

summary

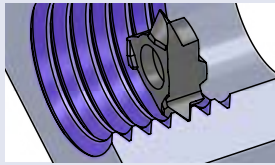

Schneideinsatz
Gewindefräsen

inserts
thread milling

Maße
dimensions
[mm]

Seite
page

... ↴

Typ Z28	metrisches ISO-Gewinde, Teilprofil, innen	metric ISO-thread, partial profile, internal	Gewinde-/ thread- Ø ≥ 33 x 1.0	... 83
Typ Z628	metrisches ISO-Gewinde, Teilprofil, innen	metric ISO-thread, partial profile, internal	Gewinde-/ thread- Ø ≥ 33 x 1.5	... 84
Typ Z622	metrisches ISO-Gewinde, Vollprofil, außen	metric ISO-thread, full profile, external	Steigung / pitch P = 1.5 - 4.0	... 85
Typ Z12	Whitworth- Gewinde Vollprofil, innen	Whitworth thread full profile, internal	Gewinde-/ thread- Ø ≥ 15.1	... 86
Typ Z614	Whitworth- Gewinde Vollprofil, innen	Whitworth thread full profile, internal	Gewinde-/ thread- Ø ≥ 17.5	... 87
Typ Z16	Whitworth- Gewinde Vollprofil, innen	Whitworth thread full profile, internal	Gewinde-/ thread- Ø ≥ 22.0	... 88
Typ Z18	Whitworth- Gewinde Vollprofil, innen	Whitworth thread full profile, internal	Gewinde-/ thread- Ø ≥ 25.6	... 89
Typ Z22	Whitworth- Gewinde Vollprofil, innen	Whitworth thread full profile, internal	Gewinde-/ thread- Ø ≥ 38.3	... 90
Typ Z622	Whitworth- Gewinde Vollprofil, innen	Whitworth thread full profile, internal	Gewinde-/ thread- Ø ≥ 38.3	... 91



MINIMILL

Nut-, Formzirkular- und
Trennfräsen

groove milling by
circular interpolation,
groove and slot milling

Übersicht

summary

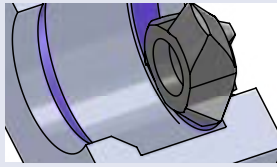

**Schneideinsatz
Fasen**

**inserts
chamfering**

**Maße
dimensions
[mm]**

**Seite
page**

Typ Z10 / Z12	Vorwärts- und Rückwärtsfasen	forward & backward chamfering	D min. 10 / 12	... 93
Typ Z610	Vorwärts- und Rückwärtsfasen	forward & backward chamfering	D min. 10	... 94
Typ Z614	Vorwärts- und Rückwärtsfasen	forward & backward chamfering	D min. 14	... 95
Typ Z16	Vorwärts- und Rückwärtsfasen	forward & backward chamfering	D min. 16	... 96
Typ Z18	Vorwärts- und Rückwärtsfasen	forward & backward chamfering	D min. 15	... 97
Typ Z18	Vorwärts- und Rückwärtsfasen mit Radius	forward & backward chamfering with radius	D min. 18	... 98
Typ Z22	Vorwärts- und Rückwärtsfasen	forward & backward chamfering	D min. 22	... 99
Typ Z618 / Z622 / Z628	Vorwärts- und Rückwärtsfasen	forward & backward chamfering	D min. 15/18/ 22 /28	... 100

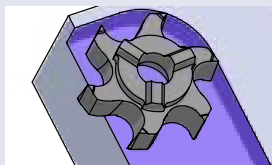

**Schneideinsatz
Stirn-/Planfräsen**

**inserts
face milling**

**Maße
dimensions
[mm]**

**Seite
page**

Typ Z620 / Z628	Stirn- und Planfräsen	face milling	D min. 20 / 28	... 101
------------------------	-----------------------	--------------	----------------	----------------

MINIMILL

Nut-, Formzirkular- und
Trennfräsen

groove milling by
circular interpolation,
groove and slot milling

Übersicht

summary

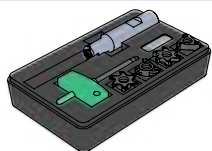

Sets Minimill

Fräseschaft und
Schneideinsätze

sets Minimill

milling shank
and inserts

Maße
dimensions
[mm]

Seite
page

SET-MINI-MILLZ12

Auswahl Z12

selection Z12

D min. 12

... 102

SET-MINI-MILLZ18

Auswahl Z18

selection Z18

D min. 18

... 102

SET-MINI-MILLZ22

Auswahl Z622 / Z22

selection Z622 / Z22

D min. 22

... 103

SET-MINI-MILLZ637

Auswahl Z637

selection Z637

D min. 37

... 103

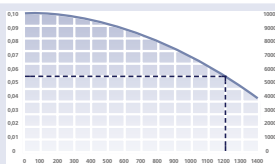

Technische Hinweise

Technical Instructions

Seite
page

Grundsätzliche Informationen
zum Gewindefräsen

basic informations about
thread milling

... 110

Hartmetallsorten und
Beschichtungen

carbide grades and coatings

...114

Ermittlung der Schnittdaten

evaluation of the cutting data

...116

Schnittdatenempfehlung

speed and feed recommendation

... 118

MINIMILL XL

Nut- und Trennfräsen

groove and slot milling

Übersicht

summary

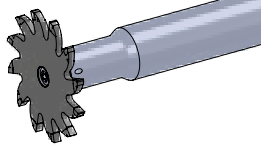

Frälerschaft

milling shank

**Maße
dimensions
[mm]**

**Seite
page**

Typ XH50

Frälerschaft Stahl

milling shank steel

Ø DS 50

... 104

Typ XH50

Frälerschaft Hartmetall

milling shank carbide

Ø DS 50

... 105

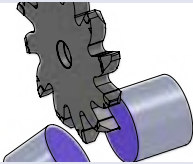

**Schneideinsatz
Nut- und Trennfräsen**

**inserts
groove and slot milling**

**Maße
dimensions
[mm]**

**Seite
page**

Typ X1250

Nut- und Trennfräsen

groove and slot milling

Ø DS 50
t max. = 16.5
b = 0.5 - 1.0

... 106

Typ X1250.X

Nut- und Trennfräsen

groove and slot milling

Ø DS 50
t max. = 16.5
b = 1.17 - 3.5

... 107

Typ X1250.X

Nut- und Trennfräsen
mit Schnittkraftreduzierung

groove and slot milling
with cutting force reduction

Ø DS 50
t max. = 16.5
b ≥ 4

... 108

Typ X1250.L6

Trennfräsen
mit 6° Schräge

slot milling
with 6° lead angle

Ø DS 50
t max. = 16.5
b = 1.0 - 2.0

... 109

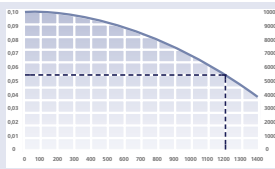

Technische Hinweise

Technical Instructions

**Seite
page**

Hartmetallsorten und
Beschichtungen

carbide grades and coatings

... 114

Ermittlung der Schnittdaten

evaluation of the cutting data

... 116

Schnittdatenempfehlung

speed and feed recommendation

... 118

MINIMILL

Nut-, Formzirkular- und
Trennfräsen

groove milling by
circular interpolation,
groove and slot milling

Allgemeine Beschreibung

general instruction

Die austauschbaren 3-,6- oder 9-schneidigen HM-Schneiden verfügen über die bewährte Dreirippenverzahnung, welche einen bestmöglichen Rundlauf garantieren. Die große Auswahl an Standard-Schneideinsätzen sind, ebenso wie die Fräseschäfte, in Stahl und Hartmetall, ab Lager lieferbar.

The indexible 3-, 6-, or 9-edged carbide inserts have the proven three-rib toothing, which guarantees the best possible concentricity. The large selection of standard inserts, as well as the milling shanks, in steel and carbide, are available on stock.



MINIMILL

Nut-, Formzirkular- und Trennfräsen

groove milling by circular interpolation, groove and slot milling

Typ ZH8

Frälerschaft Stahl

D min. 7 mm

milling shank steel

D min. 7 mm

Beispielzeichnung
exemplary application

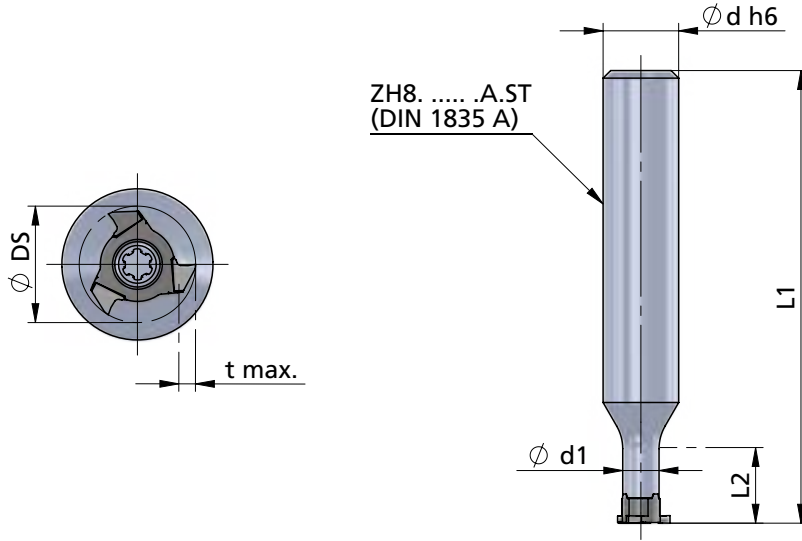

Abmessungen in mm

dimensions in mm

Bestellnummer part number	Ø d h6	Ø d1	L1	L2	Typ: t max./ Schneidkreis-Ø DS	Spannschraube screw	Schraubenschlüssel wrench	Anzugs- drehmoment torque	für Schneideinsatz for insert
ZH8.1005.10.A.ST	10	4.8	60	10	Z8: 0.6 / 6.7 Z8: 1.1 / 7.7 Z8: 1.6 / 8.7 Z8: 2.6 / 10.7	A.SPS017	T7F-P	0.8 Nm	Z8...

MINIMILL

Nut-, Formzirkular- und
Trennfräsen

groove milling by
circular interpolation,
groove and slot milling

Typ ZH8

Fräseschaft Hartmetall

D min. 7 mm

milling shank carbide

D min. 7 mm

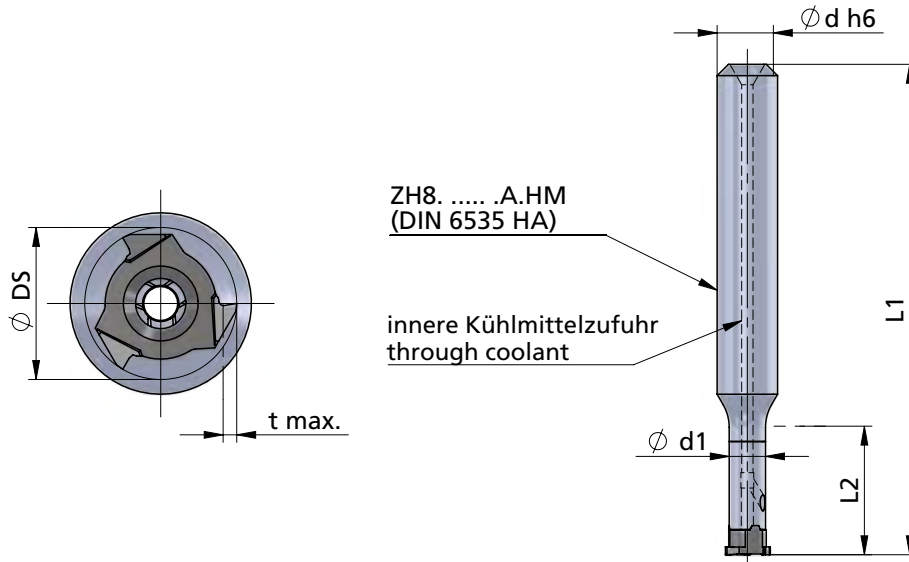

Beispielzeichnung
exemplary application

Abmessungen und Beschreibungen
gelten für alle Varianten

dimensions and descriptions are
valid for all versions

Abmessungen in mm

dimensions in mm



Bestellnummer part number	Ø d h6	Ø d1	L1	L2	Typ: t max./ Schneidkreis-Ø DS	Spannschraube screw	Schraubenschlüssel wrench	Anzugs- drehmoment torque	für Schneideinsatz for insert
ZH8.0805.17.A.HM	8	4.8	65	17	Z8: 0.6 / 6.7 Z8: 1.1 / 7.7 Z8: 1.6 / 8.7 Z8: 2.6 / 10.7	A.SPS017	T7F-P	0.8 Nm	Z8...
ZH8.0805.25.A.HM	8	4.8	75	25					
ZH8.0805.35.A.HM	8	4.8	85	35					

Bestellbeispiel:
ZH8.0805.17.A.HM

order-example:
ZH8.0805.17.A.HM

MINIMILL

Nut-, Formzirkular- und
Trennfräsen

groove milling by
circular interpolation,
groove and slot milling

Typ ZH10

Frärschaft Stahl

D min. 10 mm

milling shank steel

D min. 10 mm

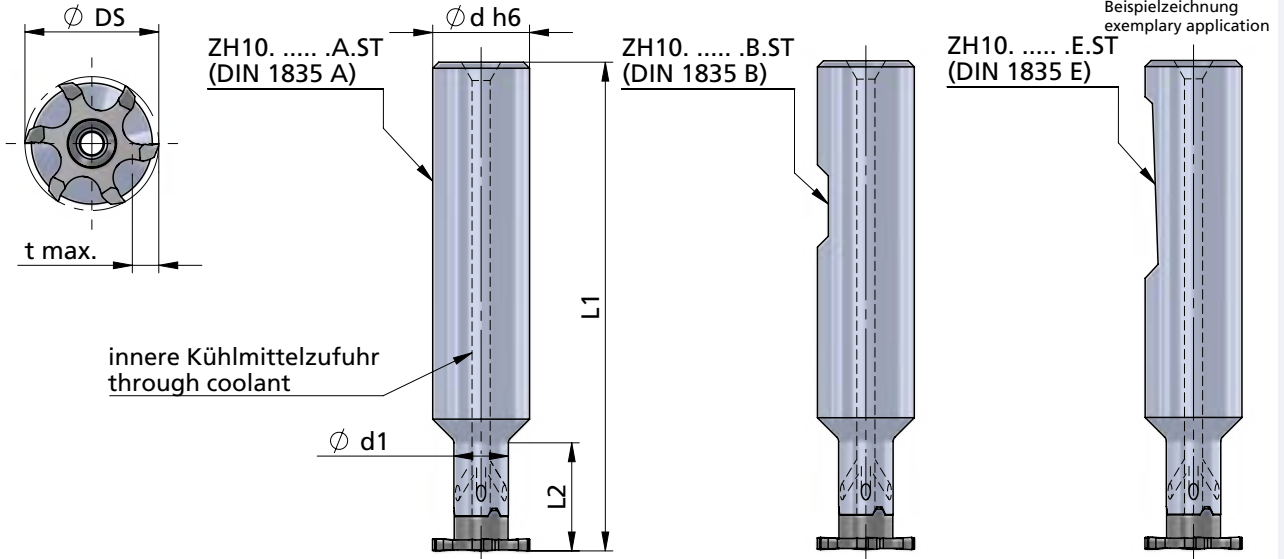

Abmessungen und Beschreibungen
gelten für alle Varianten

dimensions and descriptions are
valid for all versions

Abmessungen in mm

dimensions in mm



Bestellnummer part number	Ø d h6	Ø d1	L1	L2	Typ: t max./ Schneidkreis-Ø DS	Spannschraube screw	Schraubenschlüssel wrench	Anzugs- drehmoment torque	für Schneideinsatz for insert
ZH10.0606.15.A.ST	6	6	50	15	Z10: 1.5 / 9.7	A.SPS016	T8F-P	1.2 Nm	Z10... Z12... Z610... Z612...
ZH10.1006.15.A.ST	10	6	60	15	Z12: 2.5 / 11.7				
ZH10.1606.12.A.ST / ...B.ST / ...E.ST	16	6	80	12	Z612: 2 / 11.7				

MINIMILL

Nut-, Formzirkular- und Trennfräsen

groove milling by circular interpolation, groove and slot milling

Typ ZH10

Frälerschaft Hartmetall

D min. 10 mm

milling shank carbide

D min. 10 mm

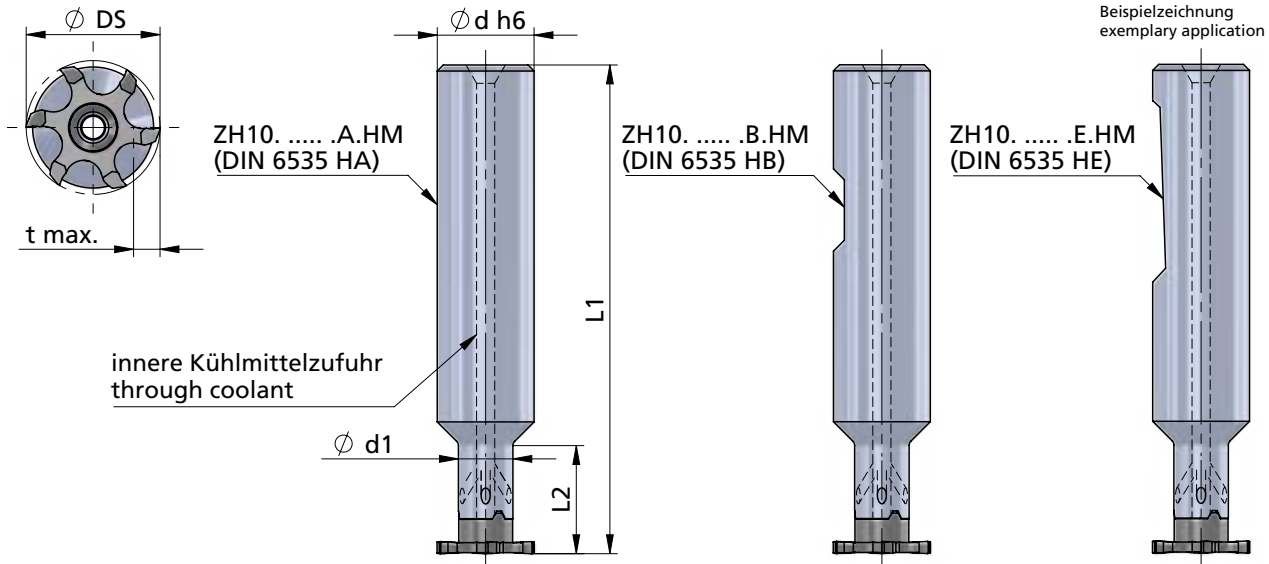

Abmessungen und Beschreibungen gelten für alle Varianten

dimensions and descriptions are valid for all versions

Abmessungen in mm

dimensions in mm



Bestellnummer part number	Ø d h6	Ø d (inch)	Ø d1	L1	L2	Typ: t max./ Schneidkreis-Ø DS	Spannschraube screw	Schraubenschlüssel wrench	Anzugs- drehmoment torque	für Schneideinsatz for insert
ZH10.1206.21.A.HM /...B.HM /...E.HM	12	6	80	21						
ZH10.U1206.21.A.HM /...B.HM	12.7	1/2"	6	80	21					
ZH10.1206.30.A.HM /...B.HM /...E.HM	12	6	90	30						
ZH10.U1206.30.A.HM /...B.HM	12.7	1/2"	6	90	30					
ZH10.1206.42.A.HM /...B.HM /...E.HM	12	6	100	42		Z10: 1.5 / 9.7 Z12: 2.5 / 11.7 Z612: 2 / 11.7	A.SPS016	T8F-P	1.2 Nm	Z10... Z12... Z610... Z612...
ZH10.U1206.42.A.HM /...B.HM	12.7	1/2"	6	100	42					
ZH10.1207.30.A.HM /...B.HM /...E.HM	12	7.3	90	30		t max. reduziert				
ZH10.U1207.30.A.HM /...B.HM	12.7	1/2"	7.3	90	30	t max. reduziert				
ZH10.1607.25.A.HM /...B.HM /...E.HM	16	7.3	100	25		t max. reduced				

Hinweis:
Hartmetall-Frälerschäfte mit beschädigter Schneidplattenaufnahme können durch unseren Reparaturservice instand gesetzt werden.

Bestellbeispiel:
ZH10.1607.25.A.HM

note:
carbide-toolholder with damaged seating can be repaired by Dümmel.

order-example:
ZH10.1607.25.A.HM

MINIMILL

Nut-, Formzirkular- und Trennfräsen

groove milling by circular interpolation, groove and slot milling

Typ ZH10.ER

Fräseschaft, für Spannzangenfutter (DIN 6499)

D min. 10 mm

milling shank, for collet chucks (DIN 6499)

D min. 10 mm

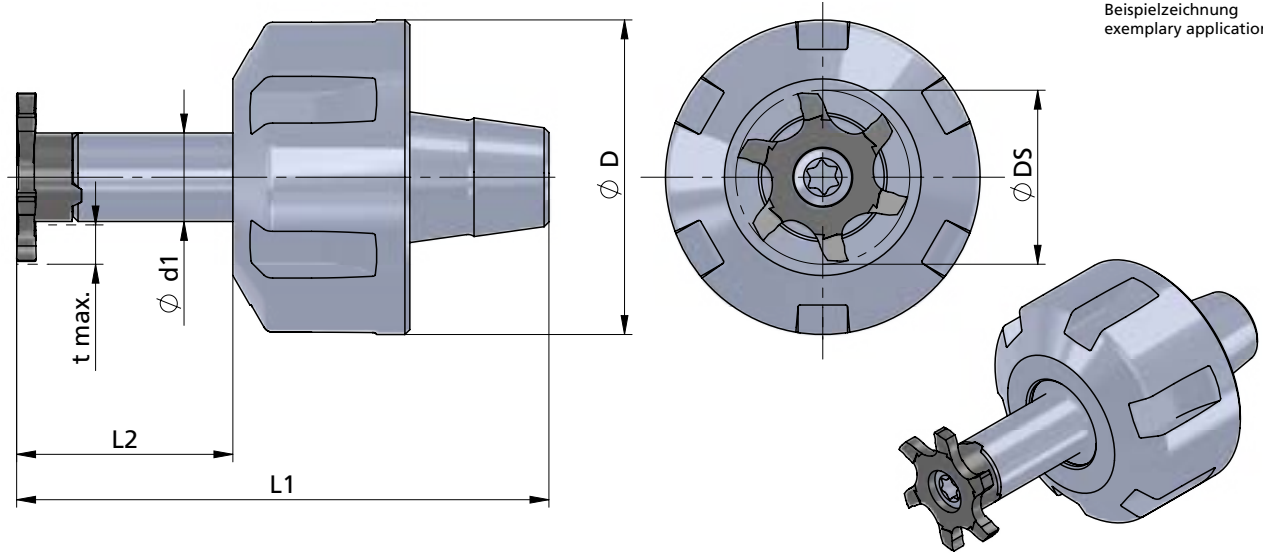

Beispielzeichnung
exemplary application

Abmessungen und Beschreibungen gelten für alle Varianten

dimensions and descriptions are valid for all versions

Abmessungen in mm

dimensions in mm

Bestellnummer part number	Ø d1	L2	Ø D	L1	Spannmutter / Gewinde clamping nut / thread	Typ: t max./ Schneidkreis-Ø DS	Spannschraube screw	Schraubenschlüssel wrench	Anzugs- drehmoment torque	für Schneideinsatz for insert
ZH10.ER11.0616.19	6	16	19	36.3	ER11.1219.SP / M14x0.75	Z10: 1.5 / 9.7	A.SPS016	T8F-P	1.2 Nm	Z10... Z12... Z610... Z612...
ZH10.ER11.0616.16	6	16	16	36.3	ER11.1216.SP / M13x0.75	Z12: 2.5 / 11.7				
						Z612: 2 / 11.7				

MINIMILL

Nut-, Formzirkular- und Trennfräsen

groove milling by circular interpolation, groove and slot milling

Typ ZH14

Frälerschaft Stahl

D min. 14 mm

milling shank steel

D min. 14 mm

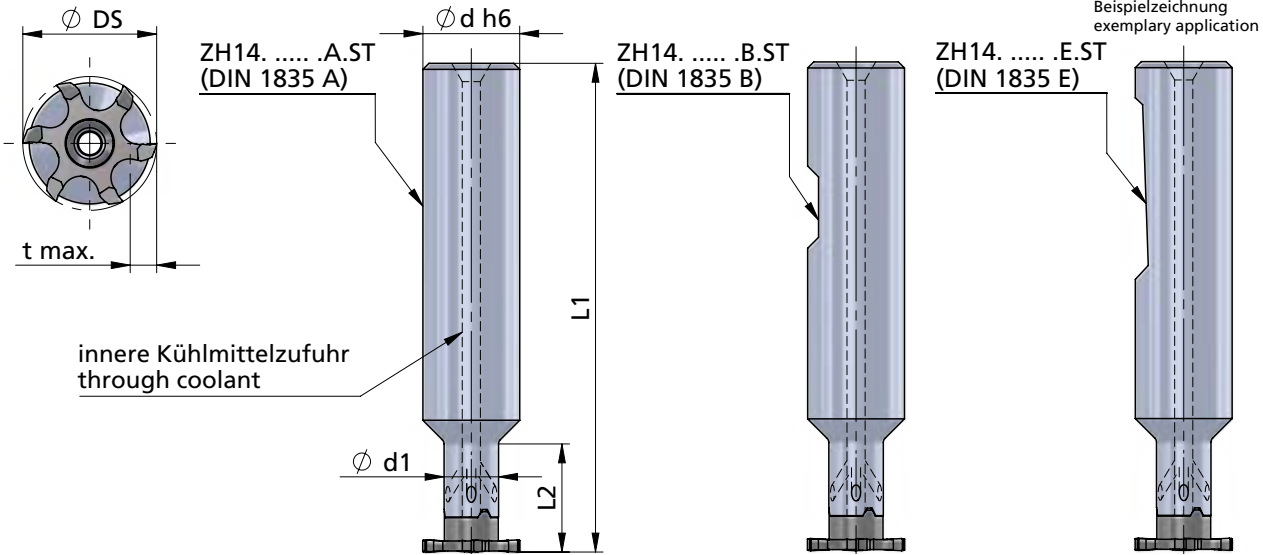

Abmessungen und Beschreibungen gelten für alle Varianten

dimensions and descriptions are valid for all versions

Abmessungen in mm

dimensions in mm



Bestellnummer part number	Abmessungen				Typ: t max./ Schneidkreis-Ø DS	Spannschraube screw	Schraubenschlüssel wrench	Anzugs- drehmoment torque	für Schneideinsatz for insert
	Ø d h6	d1	L1	L2					
ZH14.0808.15.A.ST	8	8	50	15	Z14: 2.5 / 13.7 Z16: 3.5 / 15.7 Z616: 3.5 / 15.7	A.SPS021	T10F-P	3.5 Nm	Z14... Z16... Z614... Z616...
ZH14.1008.17.A.ST	10	8	60	17					
ZH14.1308.25.A.ST	13	8	70	25					
ZH14.1608.16.A.ST /...B.ST /...E.ST	16	8	80	16					

Bestellbeispiel:
ZH14.0808.15.A.ST

order-example:
ZH14.0808.15.A.ST

MINIMILL

Nut-, Formzirkular- und
Trennfräsen

groove milling by
circular interpolation,
groove and slot milling

Typ ZH14

Fräseschaft Hartmetall

D min. 14 mm

milling shank carbide

D min. 14 mm

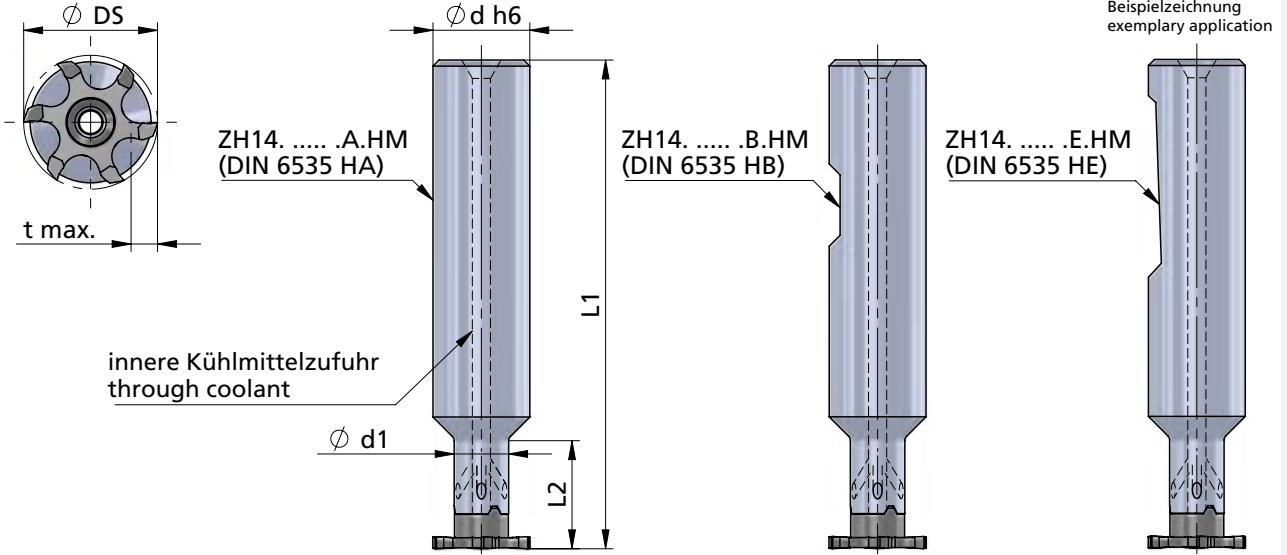

Abmessungen und Beschreibungen
gelten für alle Varianten

dimensions and descriptions are
valid for all versions

Abmessungen in mm

dimensions in mm



Bestellnummer part number	Ø d h6	Ø d (inch)	Ø d1	L1	L2	Typ: t max./ Schneidkreis-Ø DS	Spannschraube screw	Schraubenschlüssel wrench	Anzugs- drehmoment torque	für Schneideinsatz for insert
ZH14.1208.29.A.HM /...B.HM /...E.HM	12	8	95	29						
ZH14.U1208.29.A.HM /...B.HM	12.7	1/2"	8	95	29					
ZH14.1208.42.A.HM /...B.HM /...E.HM	12	8	110	42						
ZH14.U1208.42.A.HM /...B.HM	12.7	1/2"	8	110	42					
ZH14.1208.56.A.HM /...B.HM /...E.HM	12	8	120	56		Z14: 2.5 / 13.7 Z16: 3.5 / 15.7 Z616: 3.5 / 15.7	A.SPS021	T10F-P	3.5 Nm	Z14... Z16... Z614... Z616...
ZH14.U1208.56.A.HM /...B.HM	12.7	1/2"	8	120	56					
ZH14.1209.42.A.HM /...B.HM /...E.HM	12	9.5	110	42		t max. reduziert				
ZH14.U1209.42.A.HM /...B.HM	12.7	1/2"	9.5	110	42	t max. reduziert				
ZH14.1609.33.A.HM /...B.HM /...E.HM	16	9.5	110	33		t max. reduced				

Hinweis:
Hartmetall-Fräseschäfte mit beschädigter
Schneidplattenaufnahme können durch unseren
Reparaturservice instand gesetzt werden.

note:
carbide-toolholder with damaged seating can be
repaired by Dümmel.

Bestellbeispiel:
ZH14.1609.33.A.HM

order-example:
ZH14.1609.33.A.HM

MINIMILL

Nut-, Formzirkular- und Trennfräsen

groove milling by circular interpolation, groove and slot milling

Typ ZH14.ER

Fräseschaft, für Spannzangenfutter (DIN 6499)

D min. 14 mm

milling shank, for collet chucks (DIN 6499)

D min. 14 mm

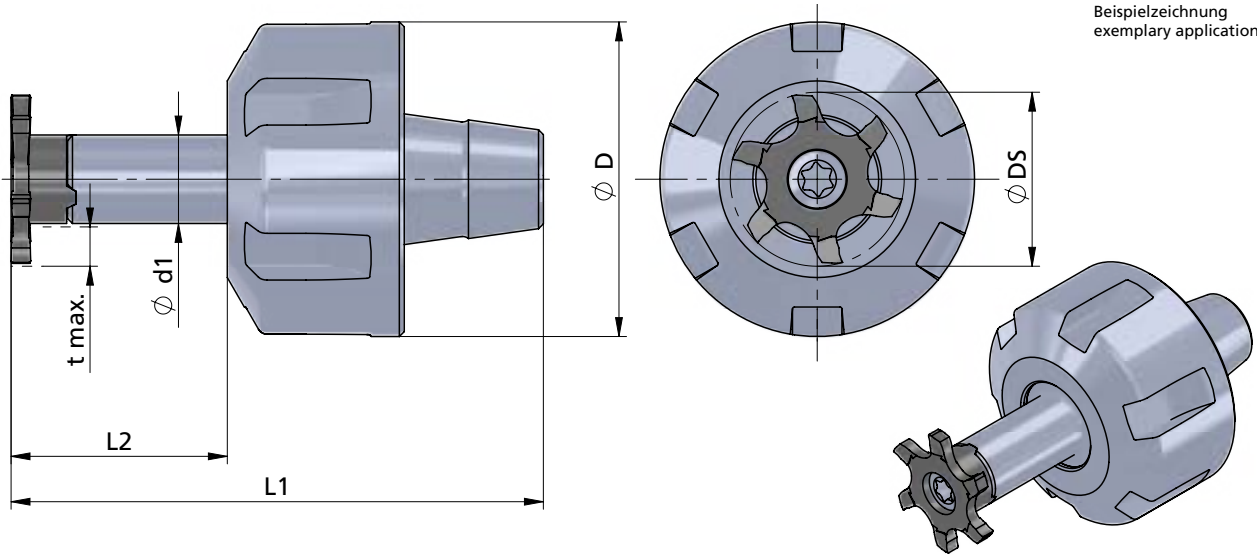

Beispielzeichnung
exemplary application

Abmessungen und Beschreibungen gelten für alle Varianten

dimensions and descriptions are valid for all versions

Abmessungen in mm

dimensions in mm



Bestellnummer part number	Ø d1	L2	Ø D	L1	Spannmutter / Gewinde clamping nut / thread	Typ: t max./ Schneidkreis-Ø DS			Spannschraube screw	Schraubenschlüssel wrench	Anzugs- drehmoment torque	für Schneideinsatz for insert
						Z14: 2.5 / 13.7	Z16: 3.5 / 15.7	Z616: 3.5 / 15.7				
ZH14.ER11.0816.19	8	16	19	36.3	ER11.1219.SP / M14x0.75							
ZH14.ER11.0816.16	8	16	16	36.3	ER11.1216.SP / M13x0.75							
ZH14.ER16.0822.32	8	22	32	52.0	ER16.1832.SP / M22x1.5							
ZH14.ER16.0822.22	8	22	22	52.0	ER16.1822.SP / M19x1.0							
ZH14.ER16.0822.25	8	22	25	52.0	ER16.1825.SP / M19x1.0							
ZH14.ER20.0822.35	8	22	35	56.5	ER20.1935.SP / M25x1.5							
ZH14.ER20.0822.28	8	22	28	56.5	ER20.1928.SP / M24x1.0							

Bestellbeispiel:
ZH14.ER11.0816.19

order-example:
ZH14.ER11.0816.19

MINIMILL

Nut-, Formzirkular- und Trennfräsen

groove milling by circular interpolation, groove and slot milling

Typ ZH18

Fräferschaft Stahl

D min. 18 mm

milling shank steel

D min. 18 mm

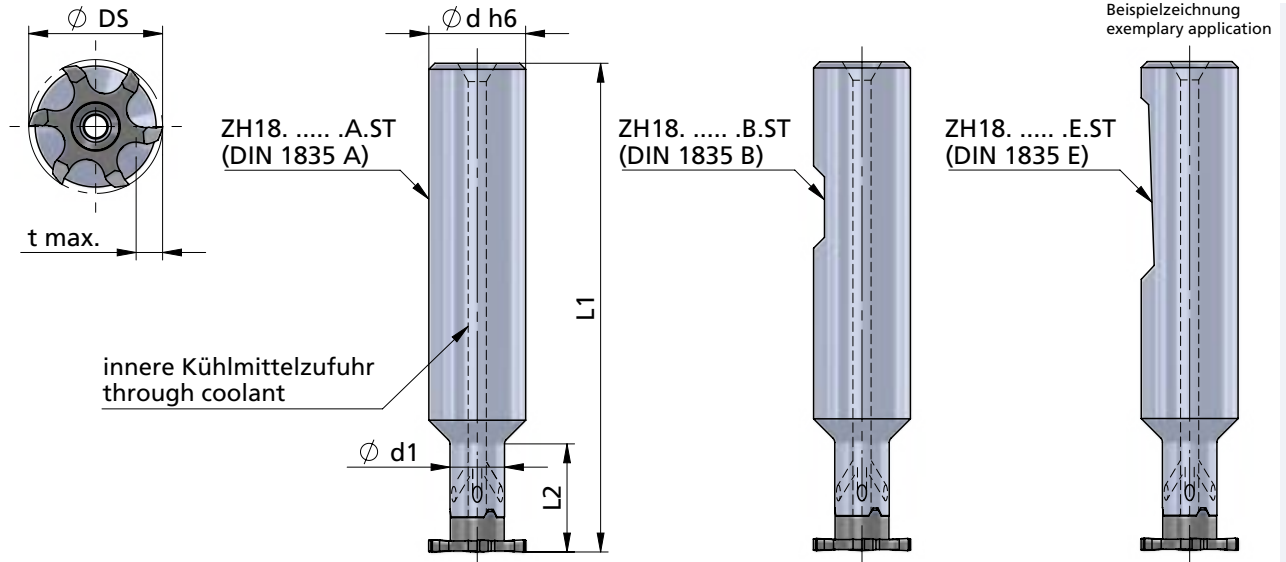

Abmessungen und Beschreibungen gelten für alle Varianten

dimensions and descriptions are valid for all versions

Abmessungen in mm

dimensions in mm



Bestellnummer part number	Abmessungen				Typ: t max./ Schneidkreis-Ø DS	Spannschraube screw	Schraubenschlüssel wrench	Anzugs- drehmoment torque	für Schneideinsatz for insert
	Ø d h6	d1	L1	L2					
ZH18.1009.17.A.ST	10	9	60	17	Z18: 3.5 / 17.7 Z618: 4 / 17.7 Z620: 5 / 19.7	A.SPS026	T15F-P	4.5 Nm	Z18... Z618... Z620...
ZH18.1309.25.A.ST	13	9	70	25					
ZH18.1609.18.A.ST /...B.ST /...E.ST	16	9	80	18					

MINIMILL

Nut-, Formzirkular- und Trennfräsen

groove milling by circular interpolation, groove and slot milling

Typ ZH18

Fräseschaft Hartmetall

D min. 18 mm

milling shank carbide

D min. 18 mm

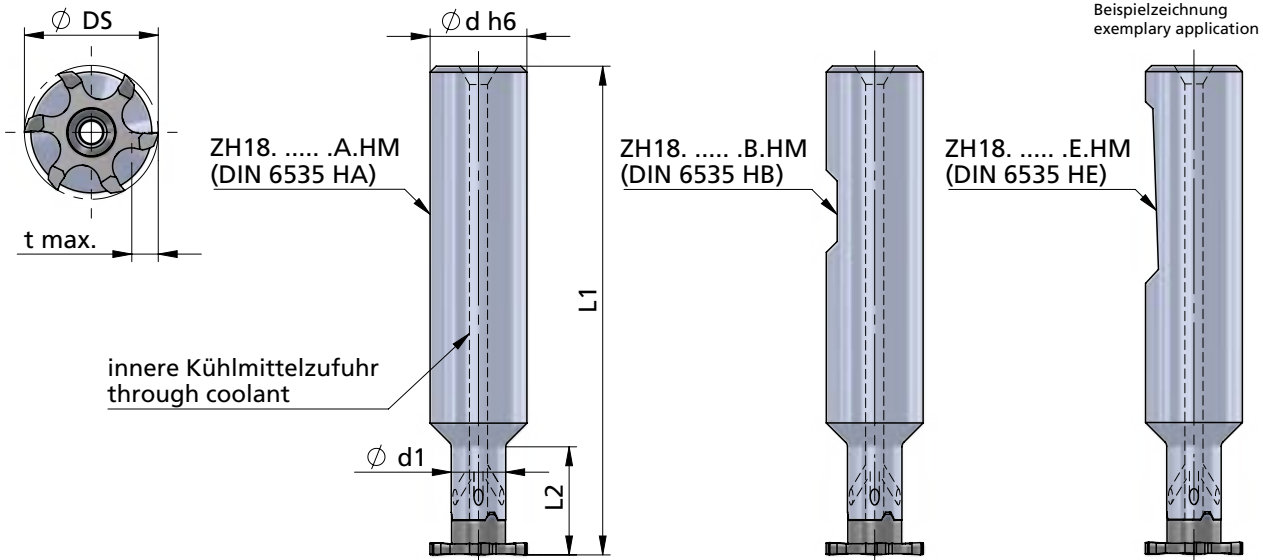

Abmessungen und Beschreibungen gelten für alle Varianten

dimensions and descriptions are valid for all versions

Abmessungen in mm

dimensions in mm



Bestellnummer part number	Ø d h6	Ø d (inch)	Ø d1	L1	L2	Typ: t max./ Schneidkreis-Ø DS	Spannschraube screw	Schraubenschlüssel wrench	Anzugs- drehmoment torque	für Schneideinsatz for insert
ZH18.1209.32.A.HM /...B.HM /...E.HM	12		9	100	32	Z18: 3.5 / 17.7 Z618: 4 / 17.7 Z620: 5 / 19.7	A.SPS026	T15F-P	4.5 Nm	Z18... Z618... Z620...
ZH18.U1209.32.A.HM /...B.HM	12.7	1/2"	9	100	32					
ZH18.1209.45.A.HM /...B.HM /...E.HM	12		9	100	45					
ZH18.U1209.45.A.HM /...B.HM	12.7	1/2"	9	100	45					
ZH18.1209.64.A.HM /...B.HM /...E.HM	12		9	120	64					
ZH18.U1209.64.A.HM /...B.HM	12.7	1/2"	9	120	64					
ZH18.U1509.45.A.HM /...B.HM	15.87	5/8"	9	110	45					
ZH18.1609.25.A.HM /...B.HM /...E.HM	16		9	93	25					
ZH18.1609.32.A.HM /...B.HM /...E.HM	16		9	100	32					
ZH18.1609.45.A.HM /...B.HM /...E.HM	16		9	110	45					
ZH18.1609.64.A.HM /...B.HM /...E.HM	16		9	130	64					
ZH18.1613.64.A.HM /...B.HM /...E.HM	16		13	110	64					
ZH18.1613.66.A.HM /...B.HM /...E.HM	16		13	130	66	t max. reduced				

Hinweis:
Hartmetall-Fräseschäfte mit beschädigter Schneidplattenaufnahme können durch unseren Reparaturservice instand gesetzt werden.

Bestellbeispiel:
ZH18.1613.66.A.HM

note:
carbide-toolholder with damaged seating can be repaired by Dümmel.

order-example:
ZH18.1613.66.A.HM

MINIMILL

Nut-, Formzirkular- und
Trennfräsen

groove milling by
circular interpolation,
groove and slot milling

Typ ZH18.ER

Fräseschaft,
für Spannzangenfutter (DIN 6499)

D min. 18 mm

milling shank,
for collet chucks (DIN 6499)

D min. 18 mm

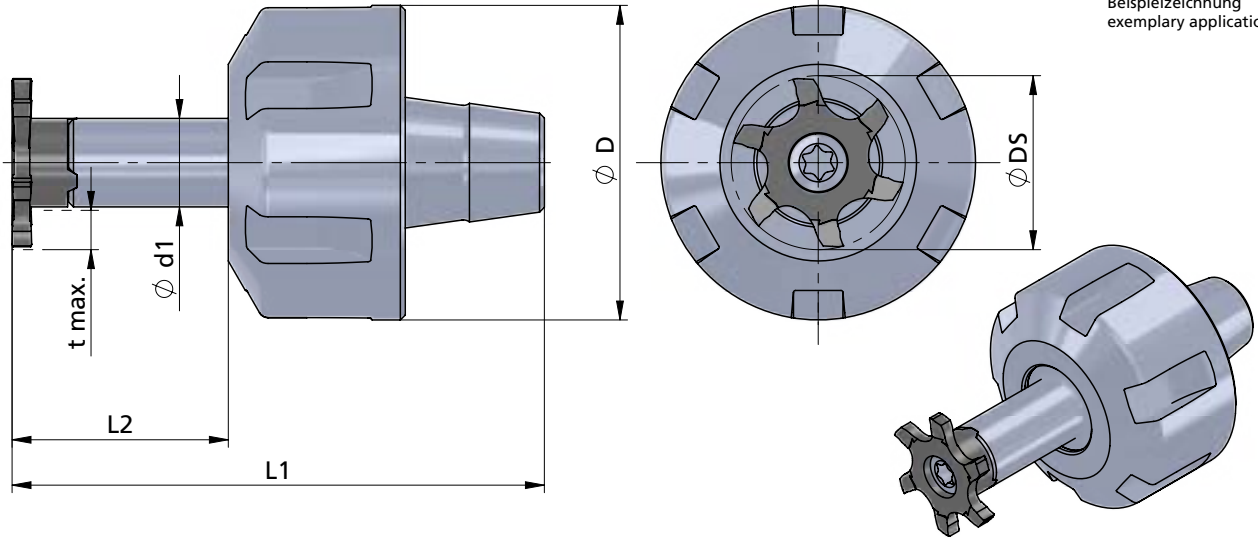

Beispielzeichnung
exemplary application

Abmessungen und Beschreibungen
gelten für alle Varianten

dimensions and descriptions are
valid for all versions

Abmessungen in mm

dimensions in mm

Bestellnummer part number	Ø d1	L2	Ø D	L1	Spannmutter / Gewinde clamping nut / thread	Typ: t max./ Schneidkreis-Ø DS	Spannschraube screw	Schraubenschlüssel wrench	Anzugs- drehmoment torque	für Schneideinsatz for insert
ZH18.ER11.0922.19	9	22	19	42.0	ER11.1219.SP / M14x0.75	Z18: 3.5 / 17.7 Z618: 4 / 17.7 Z620: 5 / 19.7	A.SPS026	T15F-P	4.5 Nm	Z18... Z618... Z620...
ZH18.ER11.0922.16	9	22	16	42.0	ER11.1216.SP / M13x0.75					
ZH18.ER16.0922.32	9	22	32	52.0	ER16.1832.SP / M22x1.5					
ZH18.ER16.0922.22	9	22	22	52.0	ER16.1822.SP / M19x1.0					
ZH18.ER16.0922.25	9	22	25	52.0	ER16.1825.SP / M19x1.0					
ZH18.ER20.0922.35	9	22	35	56.5	ER20.1935.SP / M25x1.5					
ZH18.ER20.0922.28	9	22	28	56.5	ER20.1928.SP / M24x1.0					
ZH18.ER25.0922.42	9	22	42	60.0	ER25.2042.SP / M32x1.5					
ZH18.ER25.0922.35	9	22	35	60.0	ER25.2035.SP / M30x1.0					

MINIMILL

Nut-, Formzirkular- und Trennfräsen

groove milling by circular interpolation, groove and slot milling

Typ ZH22

Fräferschaft Stahl

D min. 22 mm

milling shank steel

D min. 22 mm

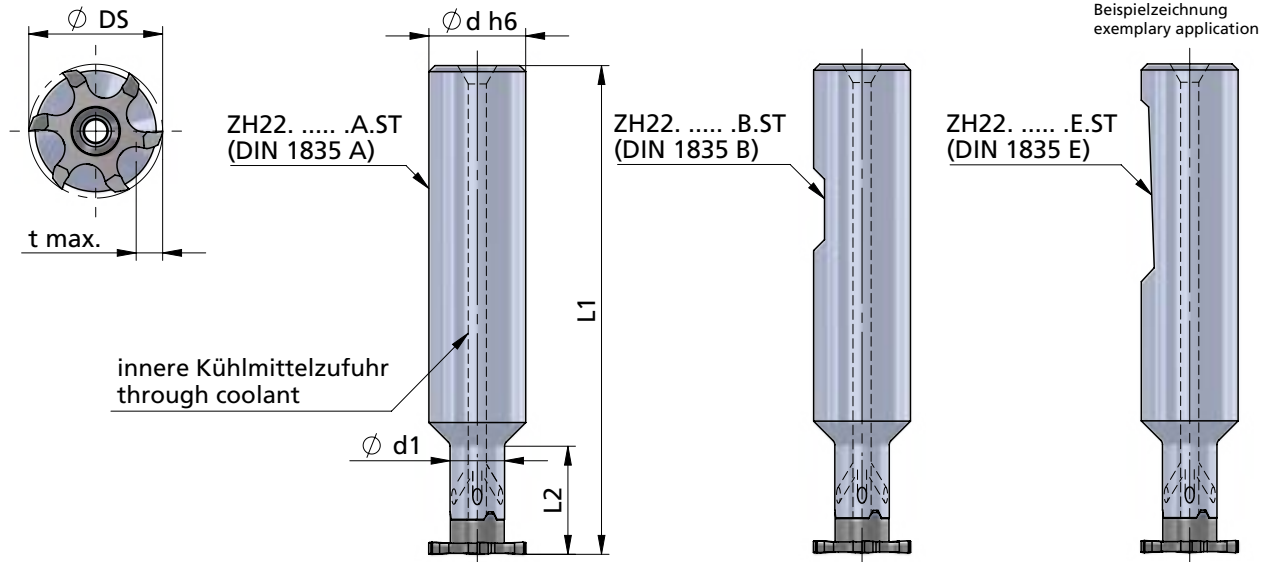

Abmessungen und Beschreibungen gelten für alle Varianten

dimensions and descriptions are valid for all versions



Abmessungen in mm

dimensions in mm



Bestellnummer part number	Abmessungen				Typ: t max./ Schneidkreis- ϕ DS	Spannschraube screw	Schraubenschlüssel wrench	Anzugs- drehmoment torque	für Schneideinsatz for insert
	$\phi d h6$	d1	L1	L2					
ZH22.1011.10.A.ST	10	11.3	60	10.7	Z22: 4.5 / 21.7 Z622: 4.5 / 21.7 Z922: 4.5 / 22 Z33: 10 / 32.7 Z637: 12 / 36.7 Z640: 13.5 / 39.7	A.SPS029	T20F-P	7.0 Nm	Z22...
ZH22.1311.25.A.ST	13	11.3	70	25.7					Z622...
ZH22.1612.24.A.ST / ...B.ST / ...E.ST	16	12	80	24					Z922...

Bestellbeispiel:
ZH22.1612.24.A.ST

order-example:
ZH22.1612.24.A.ST

MINIMILL

Nut-, Formzirkular- und Trennfräsen

groove milling by circular interpolation, groove and slot milling

Typ ZH22

Fräseschaft Hartmetall

D min. 22 mm

milling shank carbide

D min. 22 mm

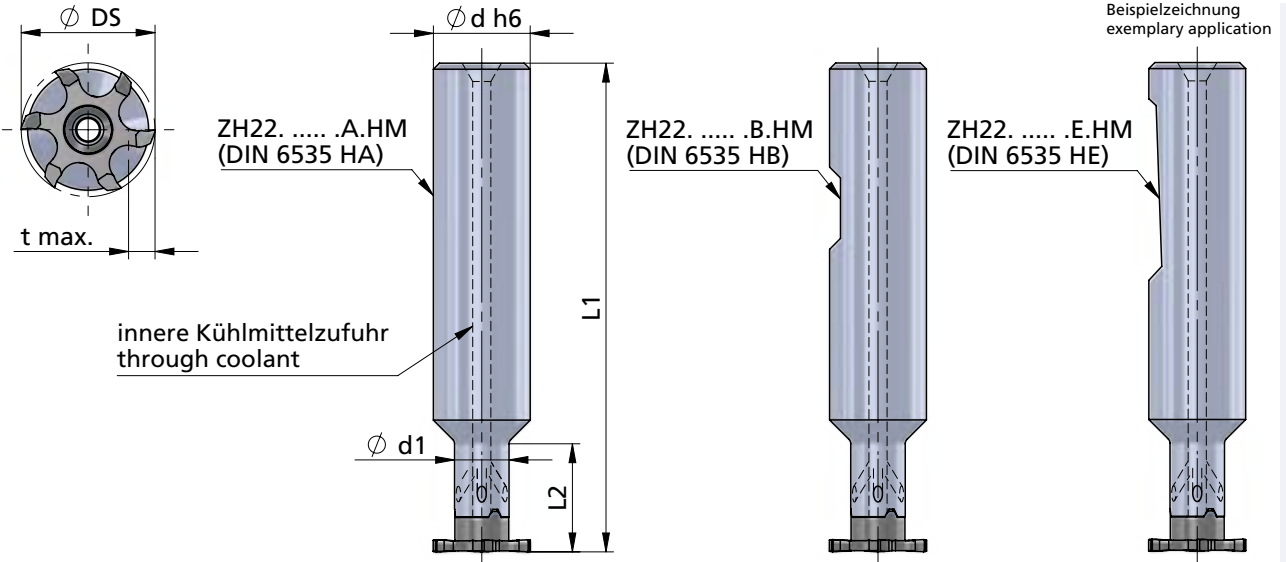

Abmessungen und Beschreibungen gelten für alle Varianten

dimensions and descriptions are valid for all versions

Abmessungen in mm

dimensions in mm



Bestellnummer part number	Ø d h6	Ø d (inch)	Ø d1	L1	L2	Typ: t max./ Schneidkreis-Ø DS	Spannschraube screw	Schraubenschlüssel wrench	Anzugs- drehmoment torque	für Schneideinsatz for insert	
ZH22.1212.42.A.HM /...B.HM /...E.HM	12	-	-	100	42	Z22: 4.5 / 21.7 Z622: 4.5 / 21.7 Z922: 4.5 / 22 Z33: 10 / 32.7 Z637: 12 / 36.7 Z640: 13.5 / 39.7	A.SPS029	T20F-P	7.0 Nm	Z22... Z622... Z922... Z33... Z637... Z640...	
ZH22.U1212.42.A.HM /...B.HM	12.7	1/2"	-	100	42						
ZH22.1212.60.A.HM /...B.HM /...E.HM	12	-	-	130	60						
ZH22.U1212.60.A.HM /...B.HM	12.7	1/2"	-	130	60						
ZH22.U1511.30.A.HM /...B.HM	15.87	5/8"	11.5	90	30						
ZH22.U1512.42.A.HM /...B.HM	15.87	5/8"	12	100	42						
ZH22.U1512.60.A.HM /...B.HM	15.87	5/8"	12	130	60						
ZH22.U1512.85.A.HM /...B.HM	15.87	5/8"	12	160	85						
ZH22.1611.30.A.HM /...B.HM /...E.HM	16	-	11.5	90	30						
ZH22.1612.42.A.HM /...B.HM /...E.HM	16	-	12	100	42						
ZH22.1612.60.A.HM /...B.HM /...E.HM	16	-	12	130	60						
ZH22.1612.85.A.HM /...B.HM /...E.HM	16	-	12	160	85						
ZH22.2016.45.A.HM /...B.HM /...E.HM	20	-	16	110	45						t max. reduziert
ZH22.2016.65.A.HM /...B.HM /...E.HM	20	-	16	130	65						t max. reduced

Hinweis:
Hartmetall-Fräseschäfte mit beschädigter Schneidplattenaufnahme können durch unseren Reparaturservice instand gesetzt werden.

note:
carbide-toolholder with damaged seating can be repaired by Dümmel.

Bestellbeispiel:
ZH22.2016.65.A.HM

order-example:
ZH22.2016.65.A.HM

MINIMILL

Nut-, Formzirkular- und Trennfräsen

groove milling by circular interpolation, groove and slot milling

Typ ZH22.ER

Fräseschaft, für Spannzangenfutter (DIN 6499)

D min. 22 mm

milling shank, for collet chucks (DIN 6499)

D min. 22 mm

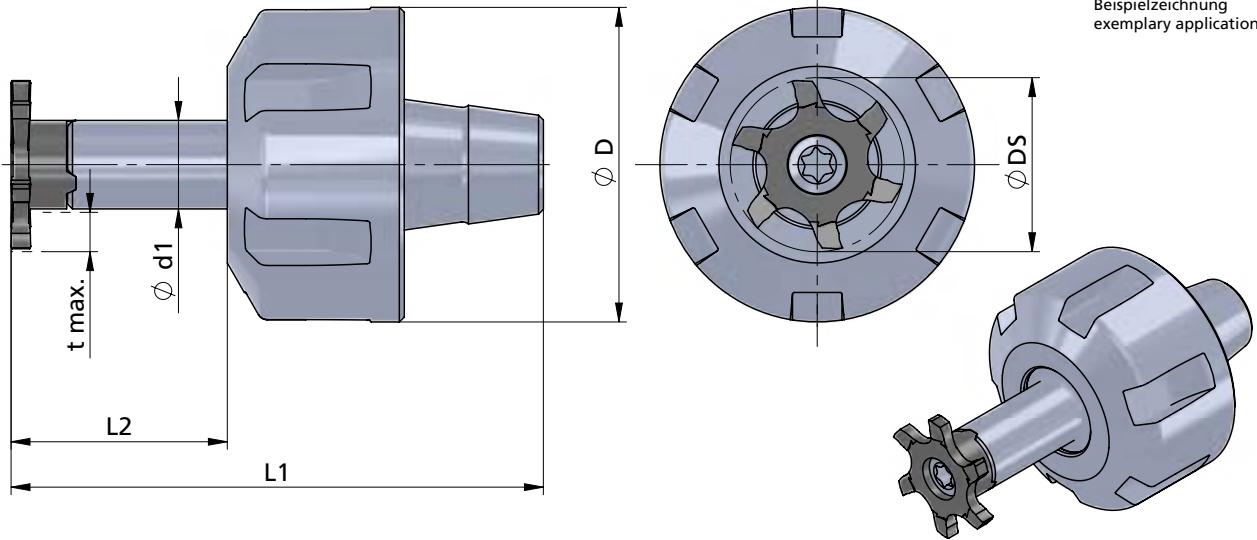

Beispielzeichnung
exemplary application

Abmessungen und Beschreibungen gelten für alle Varianten

dimensions and descriptions are valid for all versions

Abmessungen in mm

dimensions in mm



Bestellnummer part number	Ø d1	L2	Ø D	L1	Spannmutter / Gewinde clamping nut / thread	Typ: t max./ Schneidkreis-Ø DS	Spannschraube screw	Schraubenschlüssel wrench	Anzugs- drehmoment torque	für Schneideinsatz for insert
ZH22.ER16.1230.32	12	30	32	60	ER16.1832.SP / M22x1.5	Z22: 4.5 / 21.7 Z622: 4.5 / 21.7 Z922: 4.5 / 22 Z33: 10 / 32.7 Z637: 12 / 36.7 Z640: 13.5 / 39.7	A.SPS029	T20F-P	7.0 Nm	Z22... Z622... Z922... Z33... Z637... Z640...
ZH22.ER16.1230.22	12	30	22	60	ER16.1822.SP / M19x1.0					
ZH22.ER16.1230.25	12	30	25	60	ER16.1825.SP / M19x1.0					
ZH22.ER20.1230.35	12	30	35	65.5	ER20.1935.SP / M25x1.5					
ZH22.ER20.1230.28	12	30	28	65.5	ER20.1928.SP / M24x1.0					
ZH22.ER25.1230.42	12	30	42	68	ER25.2042.SP / M32x1.5					
ZH22.ER25.1230.35	12	30	35	68	ER25.2035.SP / M30x1.0					
ZH22.ER32.1230.50	12	30	50	74	ER32.2350.SP / M40x1.5					

Bestellbeispiel:
ZH22.ER16.1230.32

order-example:
ZH22.ER16.1230.32

MINIMILL

Nut-, Formzirkular- und Trennfräsen

groove milling by circular interpolation, groove and slot milling

Typ ZH28

Fräferschaft Stahl

D min. 25 mm

milling shank steel

D min. 25 mm

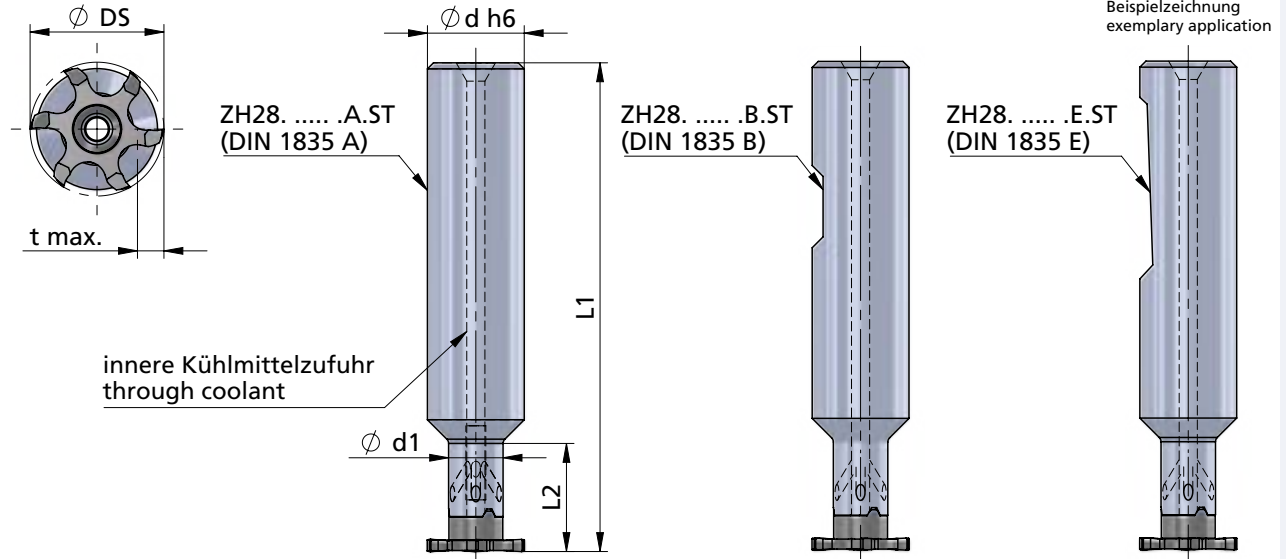

Beispielzeichnung
exemplary application

Abmessungen und Beschreibungen
gelten für alle Varianten

dimensions and descriptions are
valid for all versions

Abmessungen in mm

dimensions in mm



Bestellnummer part number	Ø d h6	d1	L1	L2	Typ: t max./ Schneidkreis-Ø DS	Spannschraube screw	Schraubenschlüssel wrench	Anzugs- drehmoment torque	für Schneideinsatz for insert
ZH28.1314.10.A.ST	13	14	70	10.7	Z25: 5 / 24.8 Z28: 6.5 / 27.7 Z628: 6.5 / 27.7 Z928: 6.5 / 28 Z32: 8.5 / 31.7 Z635: 10 / 34.7	A.SPS029	T20F-P	7.0 Nm	Z25... Z28... Z628... Z928... Z32... Z635...

MINIMILL

Nut-, Formzirkular- und Trennfräsen

groove milling by circular interpolation, groove and slot milling

Typ ZH28

Fräseschaft Hartmetall

D min. 25 mm

milling shank carbide

D min. 25 mm

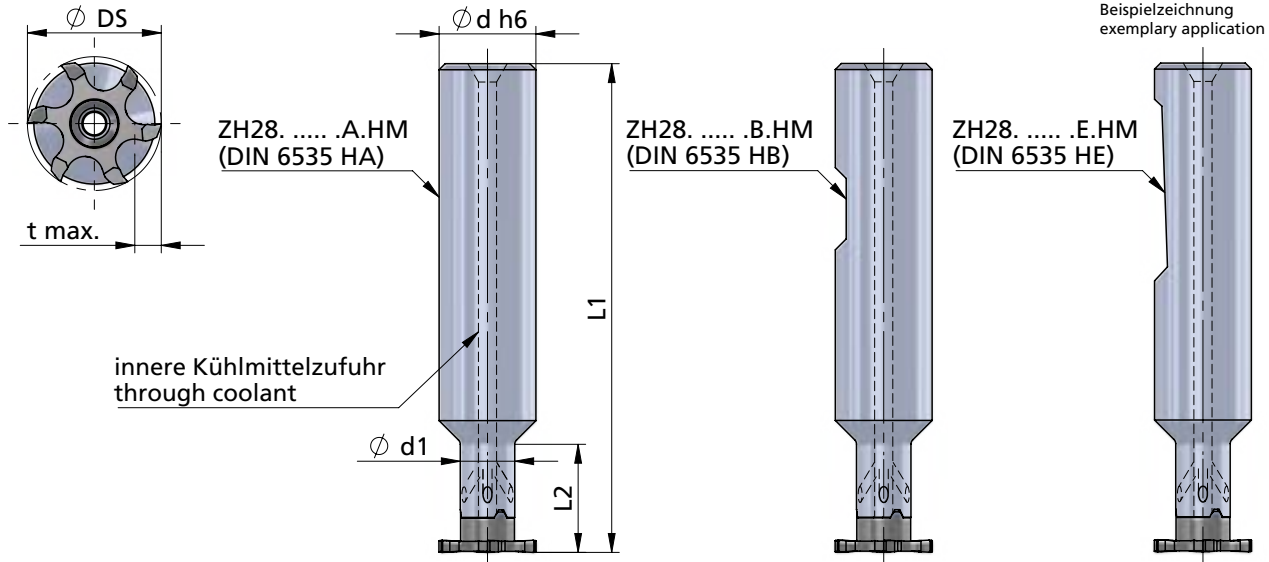

Abmessungen und Beschreibungen gelten für alle Varianten

dimensions and descriptions are valid for all versions



Abmessungen in mm

dimensions in mm



Bestellnummer part number	Ø d h6	Ø d (inch)	Ø d1	L1	L2	Typ: t max./ Schneidkreis-Ø DS	Spannschraube screw	Schraubenschlüssel wrench	Anzugs- drehmoment torque	für Schneideinsatz for insert
ZH28.U1514.42.A.HM /...B.HM	15.87	5/8"	14.3	100	42	Z25: 5 / 24.8 Z28: 6.5 / 27.7 Z628: 6.5 / 27.7 Z928: 6.5 / 28 Z32: 8.5 / 31.7 Z635: 10 / 34.7	A.SPS029	T20T-P	7.0 Nm	Z25... Z28... Z628... Z928... Z32... Z635...
ZH28.U1514.60.A.HM /...B.HM	15.87	5/8"	14.3	130	60					
ZH28.U1514.85.A.HM /...B.HM	15.87	5/8"	14.3	160	85					
ZH28.1614.42.A.HM /...B.HM /...E.HM	16		14.3	100	42					
ZH28.1614.60.A.HM /...B.HM /...E.HM	16		14.3	130	60					
ZH28.1614.85.A.HM /...B.HM /...E.HM	16		14.3	160	85					
ZH28.2013.35.A.HM /...B.HM /...E.HM	20		13.5	104	35					
ZH28.2014.85.A.HM /...B.HM /...E.HM	20		14.3	160	85					

Hinweis:
Hartmetall-Fräseschäfte mit beschädigter Schneidplattenaufnahme können durch unseren Reparaturservice instand gesetzt werden.

note:
carbide-toolholder with damaged seating can be repaired by Dümmel.

Bestellbeispiel:
ZH28.2014.85.A.HM

order-example:
ZH28.2014.85.A.HM

MINIMILL

Nut-, Formzirkular- und
Trennfräsen

groove milling by
circular interpolation,
groove and slot milling

Typ ZH28

Fräseschaft Schwermetall

D min. 28 mm

milling shank heavy metal

D min. 28 mm

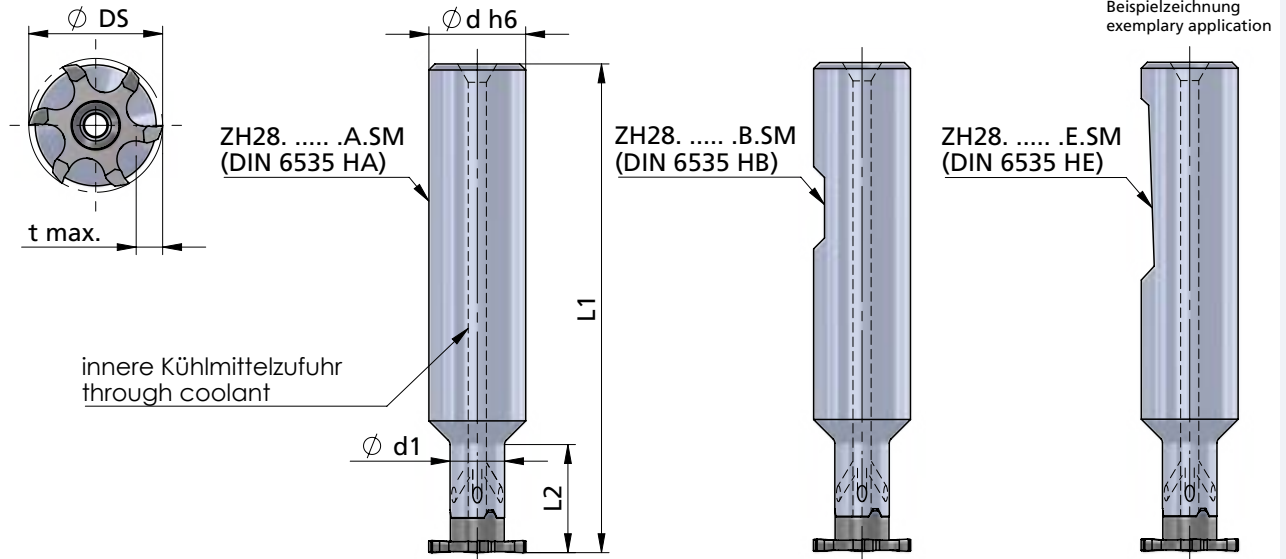

Abmessungen und Beschreibungen
gelten für alle Varianten

dimensions and descriptions are
valid for all versions

Abmessungen in mm

dimensions in mm



Bestellnummer part number	$\varnothing d h6$	$d1$ *	L1	L2	Typ: t max./ * Schneidkreis- $\varnothing DS$	Spannschraube screw	Schraubenschlüssel wrench	Anzugs- drehmoment torque	für Schneideinsatz for insert
ZH28.2015.20.A.SM /...B.SM /...E.SM	20	15	130	20	Z28: 6.5 / 27.7 Z628: 6.5 / 27.7 Z928: 6.5 / 28 Z32: 8.5 / 31.7 Z635: 10 / 34.7	A.SPS029	T20T-P	7.0 Nm	Z28... Z628... Z928... Z32... Z635...
ZH28.2020.35.A.SM /...B.SM /...E.SM	20	20	145	-					
ZH28.2015.30.A.SM /...B.SM /...E.SM	20	15	160	30					
ZH28.2020.90.A.SM /...B.SM /...E.SM	20	20	200	-					

* Achtung:
Durch die extrastabile Ausführung ist das t max.
reduziert.

* attention:
The measure t max. is reduced by the
extra-stable implementation.

MINIMILL

Nut-, Formzirkular- und Trennfräsen

groove milling by circular interpolation, groove and slot milling

Typ ZH28.ER

Fräseschaft, für Spannzangenfutter (DIN 6499)

D min. 25 mm

milling shank, for collet chucks (DIN 6499)

D min. 25 mm

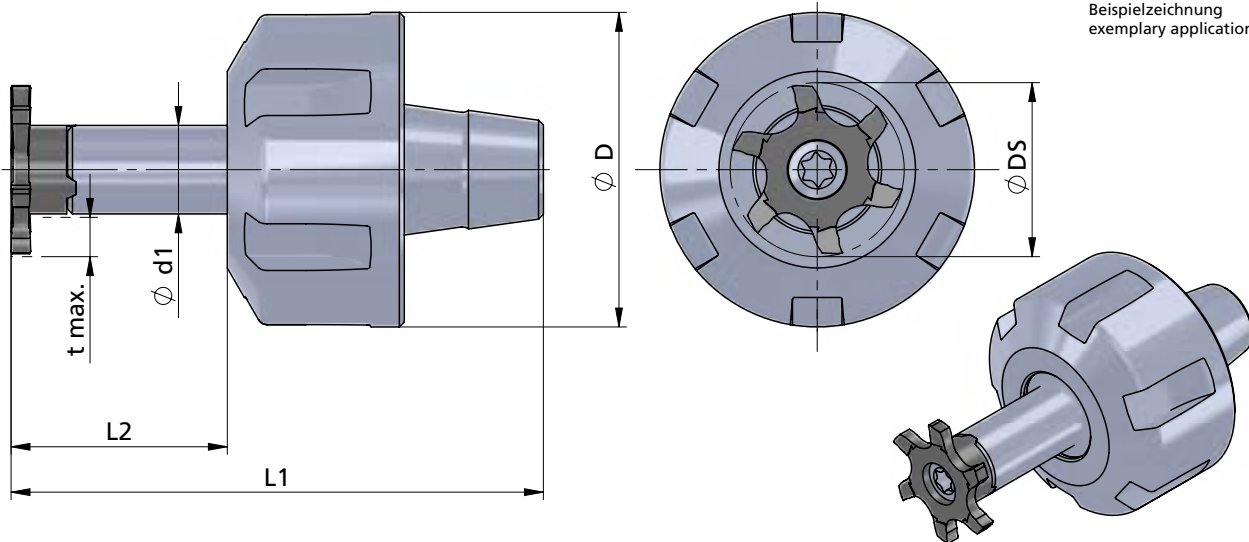

Beispielzeichnung
exemplary application

Abmessungen und Beschreibungen gelten für alle Varianten

dimensions and descriptions are valid for all versions

Abmessungen in mm

dimensions in mm



Bestellnummer part number	Ø d1	L2	Ø D	L1	Spannmutter / Gewinde clamping nut / thread	Typ: t max./ Schneidkreis-Ø DS	Spannschraube screw	Schraubenschlüssel wrench	Anzugs- drehmoment torque	für Schneideinsatz for insert
ZH28.ER20.1435.35	14	35	35	69.5	ER20.1935.SP / M25x1.5	Z25: 5 / 24.8 Z28: 6.5 / 27.7 Z628: 6.5 / 27.7 Z928: 6.5 / 28 Z32: 8.5 / 31.7 Z635: 10 / 34.7	A.SPS029	T20T-P	7.0 Nm	Z25... Z28... Z628... Z928... Z32... Z635...
ZH28.ER20.1435.28	14	35	28	69.5	ER20.1928.SP / M24x1.0					
ZH28.ER25.1419.42	14	19	42	63	ER25.2042.SP / M32x1.5					
ZH28.ER25.1419.35	14	19	35	63	ER25.2035.SP / M30x1.0					
ZH28.ER25.1435.42	14	35	42	73	ER25.2042.SP / M32x1.5					
ZH28.ER25.1435.35	14	35	35	73	ER25.2035.SP / M30x1.0					
ZH28.ER32.1419.50	14	19	50	63	ER32.2350.SP / M40x1.5					
ZH28.ER32.1435.50	14	35	50	79	ER32.2350.SP / M40x1.5					

Bestellbeispiel:
ZH28.ER20.1435.35

order-example:
ZH28.ER20.1435.35

MINIMILL

Nut-, Formzirkular- und Trennfräsen

groove milling by circular interpolation, groove and slot milling

Typ ZH33

Fräseschaft
Stahl und Hartmetall

milling shank
steel and carbide

D min. 28 mm

D min. 28 mm

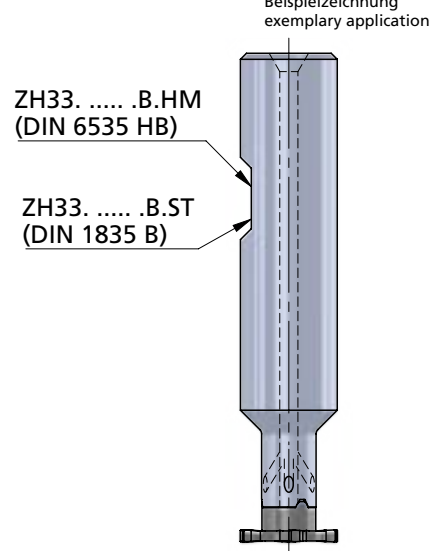
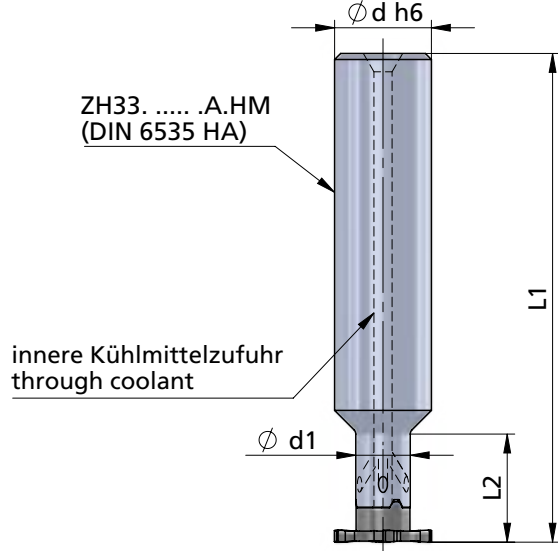
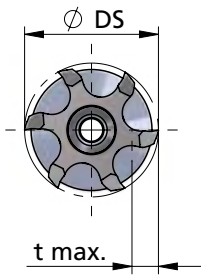

Abmessungen und Beschreibungen gelten für alle Varianten

dimensions and descriptions are valid for all versions

Abmessungen in mm

dimensions in mm



Bestellnummer part number	Ø d h6				Typ: t max./ Schneidkreis-Ø DS	Spannschraube screw	Schraubenschlüssel wrench	Anzugs- drehmoment torque	für Schneideinsatz for insert
	d1	L1	L2						
ZH33.1609.20.B.ST	16	9	80	20	Z28: 9.3 / 28 Z628.....9 : 9.3 / 27.7 Z33.....12 : 12 / 33.6	A.SP5029	T20F-P	7.0 Nm	Z28. 9 Z628. 9 Z33.170.42.12
ZH33.1209.32.A.HM / -	12	9	100	32					
ZH33.1609.33.A.HM / ...B.HM	16	9	100	33					

Hinweis:
Hartmetall-Fräseschäfte mit beschädigter Schneidplattenaufnahme können durch unseren Reparaturservice instand gesetzt werden.

note:
carbide-toolholder with damaged seating can be repaired by Dümmel.

Bestellbeispiel:
ZH33.1609.20.B.ST

order-example:
ZH33.1609.20.B.ST

MINIMILL

Nut-, Formzirkular- und
Trennfräsen

groove milling by
circular interpolation,
groove and slot milling

Impressionen

impressions



MINIMILL

Nut-, Formzirkular- und Trennfräsen

groove milling by circular interpolation, groove and slot milling

Typ Z8

Sicherungsringe DIN 471 / 472

D min. 7 mm
t max. = 0.6

for circlip grooves DIN 471 / 472

D min. 7 mm
t max. = 0.6

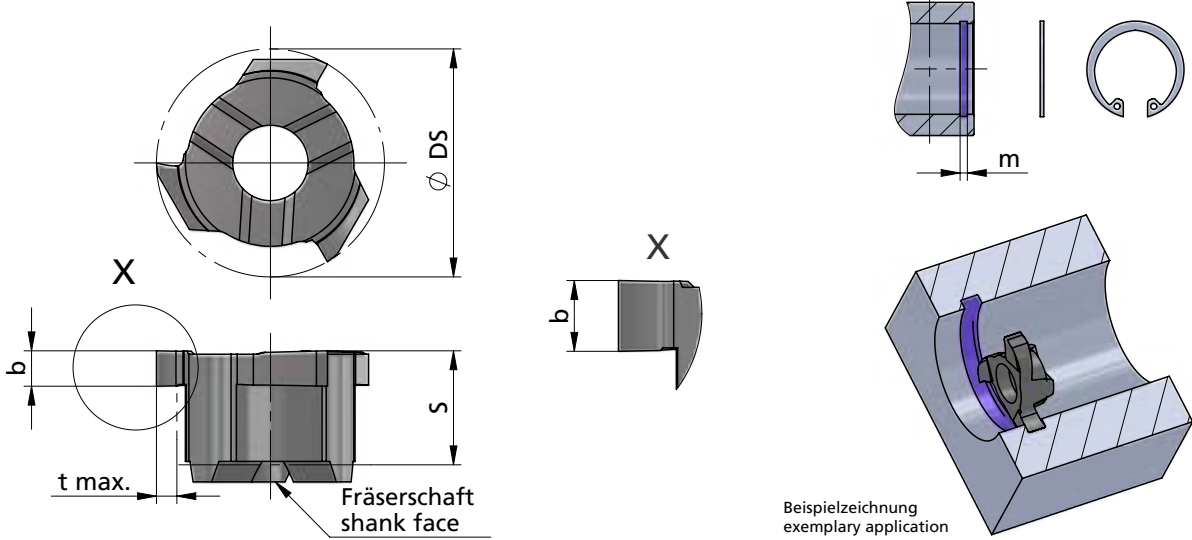

Abmessungen in mm

dimensions in mm

Bestellnummer part number	D min.	Nut-Maß m groove dim. m DIN 471 / DIN 472	s	$\varnothing DS$	b -0.02	t max.	Zähnezahl number of teeth	K10F AL41F P18C	für Fräterschaft for milling shank
Z8.S090.00.7	7.0	0.9	3.35	6.7	0.97	0.6	3	●	
Z8.S100.00.7	7.0	1.0	3.35	6.7	1.07	0.6	3	●	ZH8, ...
Z8.S110.00.7	7.0	1.1	3.35	6.7	1.24	0.6	3	●	

Weitere HM Sorten können Sie in der Sortenübersicht im Kapitel "Technische Hinweise" und der Preisliste finden.

More carbide grades you can find in the grades summary in the chapter "technical instructions" and in the price list.

MINIMILL

Nut-, Formzirkular- und Trennfräsen

groove milling by circular interpolation, groove and slot milling

Typ Z8

Nut- und Trennfräsen

groove and slot milling

D min. 7 / 8 / 9 / 11 mm
t max. = 0.6 / 1.1 / 1.6 / 2.6

D min. 7 / 8 / 9 / 11 mm
t max. = 0.6 / 1.1 / 1.6 / 2.6

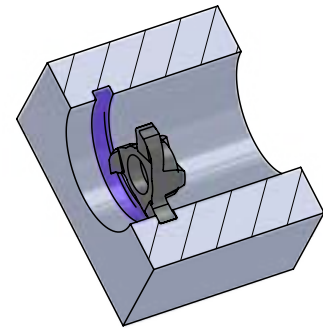
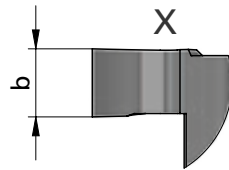
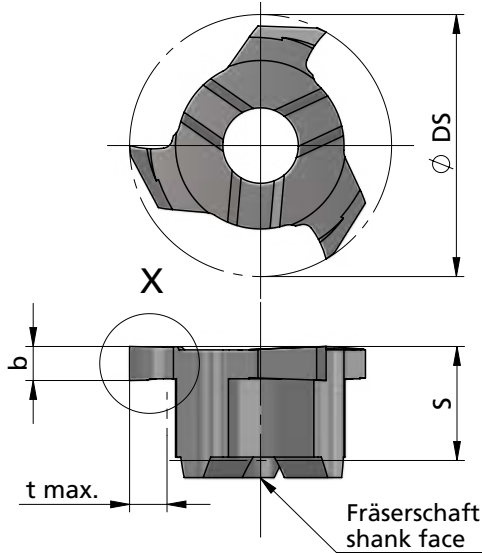

Beispielzeichnung
exemplary application



Abmessungen in mm

dimensions in mm

Bestellnummer part number	D min.	S	Ø DS	b +0.02	t max.	Zähnezahl number of teeth				für Fräaserschaft for milling shank
							K10F	AL41F	P18C	
Z8.0030.00	8.0	3.25	7.7	0.3	1.1	3		●		ZH8, ...
Z8.0030.00.11	11	3.25	10.7	0.3	2.6	3		●		
Z8.0040.00	8.0	3.25	7.7	0.4	1.1	3		●		
Z8.0040.00.11	11	3.25	10.7	0.4	2.6	3		●		
Z8.0050.00.7	7.0	3.25	6.7	0.5	0.6	3		●		
Z8.0050.00	8.0	3.25	7.7	0.5	1.1	3		●		
Z8.0050.00.11	11	3.25	10.7	0.5	2.6	3		●		
Z8.0060.00	8.0	3.25	7.7	0.6	1.1	3		●		
Z8.0070.00	8.0	3.35	7.7	0.7	1.1	3		●		
Z8.0080.00	8.0	3.35	7.7	0.8	1.1	3		●		
Z8.0090.00	8.0	3.35	7.7	0.9	1.1	3		●		
Z8.0100.00.7	7.0	3.35	6.7	1.0	0.6	3		●		
Z8.0100.00	8.0	3.35	7.7	1.0	1.1	3		●		
Z8.0100.00.9	9.0	3.35	8.7	1.0	1.6	3		●		

Weitere HM Sorten können Sie in der Sortenübersicht im Kapitel "Technische Hinweise" und der Preisliste finden.

Bestellbeispiel:
für Sorte AL41F:
Z8.0030.00/AL41F

More carbide grades you can find in the grades summary in the chapter "technical instructions" and in the price list.

order-example:
grade AL41F:
Z8.0030.00/AL41F

MINIMILL

Nut-, Formzirkular- und
Trennfräsen

groove milling by
circular interpolation,
groove and slot milling

Typ Z10

Sicherungsringe DIN 471 / 472
und Nutfräsen allgemein

D min. 10 mm
t max. = 1.5

for circlip grooves DIN 471 / 472
and groove milling general use

D min. 10 mm
t max. = 1.5

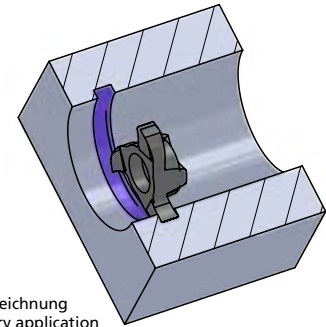
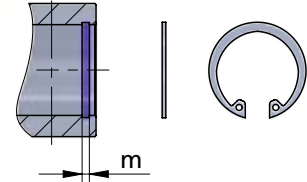
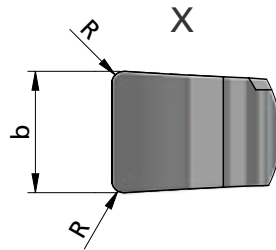
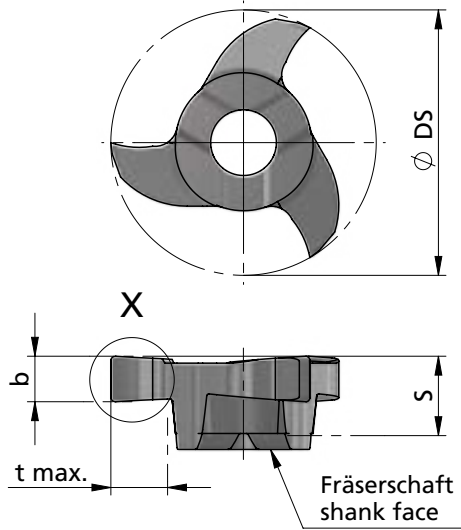

Beispielzeichnung
exemplary application

Abmessungen in mm

dimensions in mm

Bestellnummer part number	D min.	Nut-Maß m groove dim. m	DIN 471 / DIN 472	S	R	Ø DS	b +0.02 (* b -0.02)	t max.	Zähnezahl number of teeth	K10F	AL41F	P18C	für Frärschaft for milling shank
Z10.0070.00	10	0.7		3.4	-	9.7	0.74*	1.5	3	●			ZH10...
Z10.0080.00	10	0.8		3.4	-	9.7	0.84*	1.5	3	●			
Z10.0090.00	10	0.9		3.4	-	9.7	0.94*	1.5	3	●			
Z10.0100.00	10	-	-	3.4	0.1	9.7	1.00	1.5	3	●			
Z10.0110.00	10	1.1		3.5	-	9.7	1.21*	1.5	3	●			
Z10.0130.00	10	1.3		3.5	0.1	9.7	1.41*	1.5	3	●			
Z10.0150.00	10	-	-	3.5	0.2	9.7	1.50	1.5	3	●			
Z10.0160.00	10	1.6		3.5	0.1	9.7	1.71*	1.5	3	●			
Z10.0200.00	10	-	-	3.5	0.2	9.7	2.00	1.5	3	●			
Z10.0250.00	10	-	-	3.5	0.2	9.7	2.50	1.5	3	●			

Weitere HM Sorten können Sie in der Sorten-
übersicht im Kapitel "Technische Hinweise" und
der Preisliste finden.

Bestellbeispiel:
für Sorte AL41F:
Z10.0160.00/AL41F

More carbide grades you can find in the grades
summary in the chapter "technical instructions"
and in the price list.

order-example:
grade AL41F:
Z10.0160.00/AL41F

MINIMILL

Nut-, Formzirkular- und Trennfräsen

groove milling by circular interpolation, groove and slot milling

Typ Z12

Sicherungsringe DIN 471 / 472 und Nutfräsen allgemein

D min. 12 mm
t max. = 2.5

for circlip grooves DIN 471 / 472 and groove milling general use

D min. 12 mm
t max. = 2.5

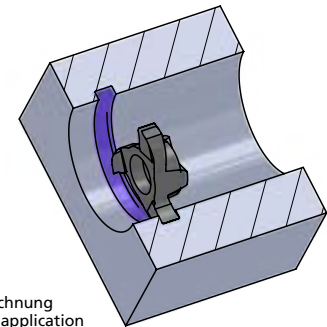
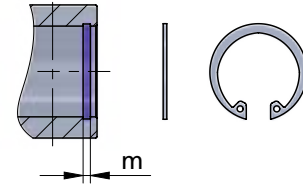
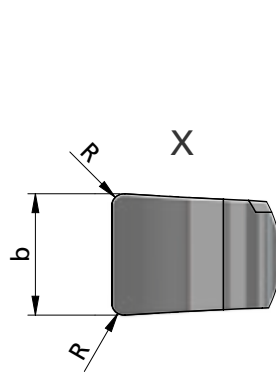
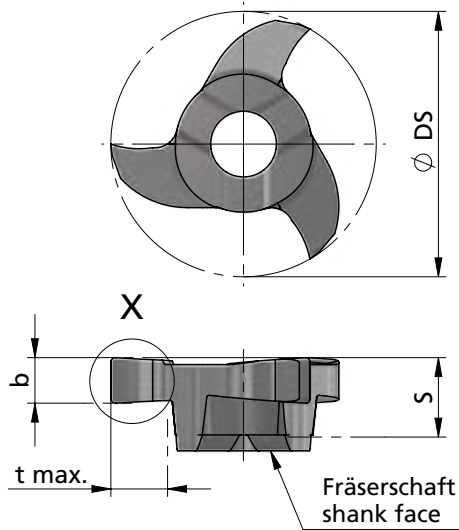

Beispielzeichnung
exemplary application

Abmessungen in mm

dimensions in mm



Bestellnummer part number	D min.	Nut-Maß m groove dim. m DIN 471 / DIN 472	S	R	Ø DS	b +0.02 (* b -0.02)	b (inch)	t max.	Zähnezahl number of teeth	Material			für Frälerschaft for milling shank
										K10F	AL41F	P18C	
Z12.0100.01	12		3.5	0.1	11.7	1.00		2.5	3	●	●	●	ZH10...
Z12.0110.00	12	1.1	3.5	-	11.7	1.21*		2.5	3	●	●	●	
Z12.0117.00	12	-	3.5	-	11.7	1.17	0.046"	2.5	3	●	●	●	
Z12.0130.00	12	1.3	3.5	0.1	11.7	1.41*		2.5	3	●	●	●	
Z12.0142.01	12	-	3.5	0.1	11.7	1.42	0.056"	2.5	3	●	●	●	
Z12.0150.02	12	-	3.5	0.2	11.7	1.50		2.5	3	●	●	●	
Z12.0157.02	12	-	3.5	0.2	11.7	1.57	0.062"	2.5	3	●	●	●	
Z12.0160.00	12	1.6	3.5	0.1	11.7	1.71*		2.5	3	●	●	●	
Z12.0198.02	12	-	3.5	0.2	11.7	1.98	0.078"	2.5	3	●	●	●	
Z12.0200.00	12	-	3.5	0.2	11.7	2.00		2.5	3	●	●	●	
Z12.0238.02	12	-	3.5	0.2	11.7	2.39	0.094"	2.5	3	●	●	●	
Z12.0250.00	12	-	3.5	0.2	11.7	2.50		2.5	3	●	●	●	
Z12.0300.00	12	-	3.5	0.2	11.7	3.00		2.5	3	●	●	●	

Weitere HM Sorten können Sie in der Sortenübersicht im Kapitel "Technische Hinweise" und der Preisliste finden.

Bestellbeispiel:
für Sorte AL41F:
Z12.0100.01/AL41F

More carbide grades you can find in the grades summary in the chapter "technical instructions" and in the price list.

order-example:
grade AL41F:
Z12.0100.01/AL41F

MINIMILL

Nut-, Formzirkular- und
Trennfräsen

groove milling by
circular interpolation,
groove and slot milling

Typ Z612 / Z612.X

Nutfräsen allgemein

D min. 12 mm
t max. = 2

groove milling general use

D min. 12 mm
t max. = 2

Z612 geradverzahnt / spur-toothed

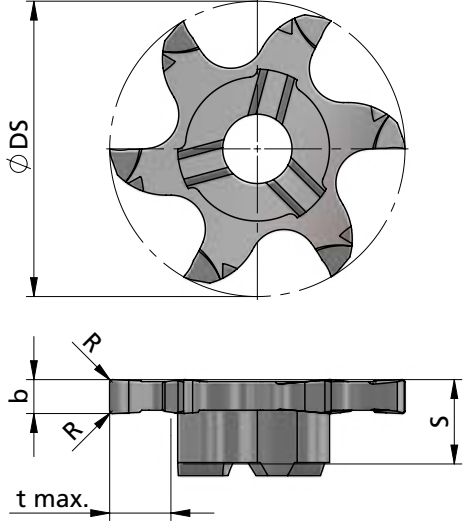

Z612.X kreuzverzahnt / staggered-toothed

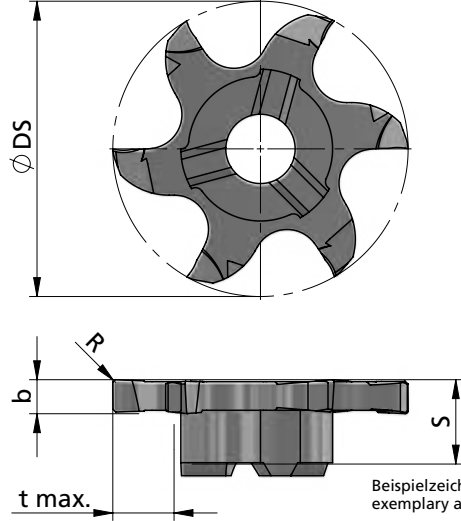

Schneide / tooth 2-4-6

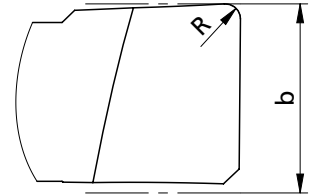

Schneide / tooth 1-3-5

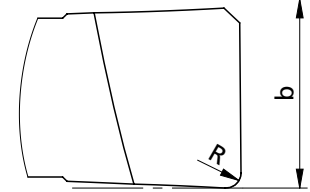

Beispielzeichnung
exemplary application

Abmessungen in mm

dimensions in mm

Bestellnummer part number	D min.	S	R	Ø DS	b +0.02	t max.	Zähnezahl number of teeth	Material			für Fräterschaft for milling shank
								K10F	AL41F	P18C	
Z612.0150.02	12	3.5	0.2	11.7	1.5	2.0	6	●			
Z612.X150.02	12	3.5	0.2	11.7	1.5	2.0	6		●		
Z612.0200.02	12	3.5	0.2	11.7	2.0	2.0	6		●		
Z612.X200.02	12	3.5	0.2	11.7	2.0	2.0	6		●		ZH10...

Weitere HM Sorten können Sie in der Sorten-
übersicht im Kapitel "Technische Hinweise" und
der Preisliste finden.

Bestellbeispiel:
für Sorte AL41F:
Z612.0150.02/AL41F

More carbide grades you can find in the grades
summary in the chapter "technical instructions"
and in the price list.

order-example:
grade AL41F:
Z612.0150.02/AL41F

MINIMILL

Nut-, Formzirkular- und Trennfräsen

groove milling by circular interpolation, groove and slot milling

Typ Z14

Nutfräsen allgemein

groove milling general use

D min. 14 mm
t max. = 2.5

D min. 14 mm
t max. = 2.5

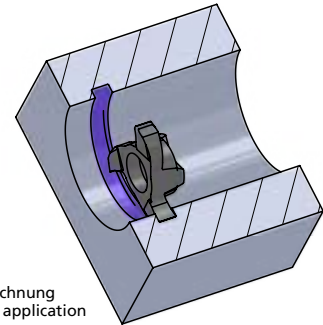
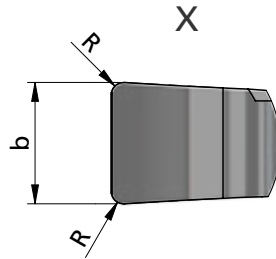
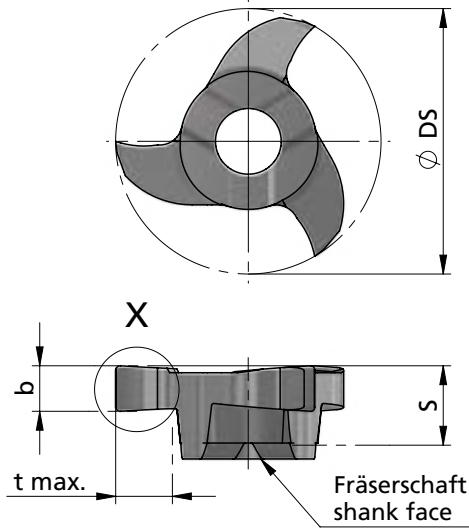

Beispielzeichnung
exemplary application



Abmessungen in mm

dimensions in mm

Bestellnummer part number	D min.	S	R	$\varnothing DS$	b +0.02	t max.	Zähnezahl number of teeth	Material			für Fräterschaft for milling shank
								K10F	AL41F	P18C	
Z14.0100.00	14	4.5	0.1	13.7	1.0	2.5	3	●			
Z14.0150.00	14	4.5	0.2	13.7	1.5	2.5	3	●			
Z14.0200.02	14	4.5	0.2	13.7	2.0	2.5	3	●			
Z14.0250.02	14	4.5	0.2	13.7	2.5	2.5	3	●			ZH14...

Weitere HM Sorten können Sie in der Sortenübersicht im Kapitel "Technische Hinweise" und der Preisliste finden.

Bestellbeispiel:
für Sorte AL41F:
Z14.0150.00/AL41F

More carbide grades you can find in the grades summary in the chapter "technical instructions" and in the price list.

order-example:
grade AL41F:
Z14.0150.00/AL41F

MINIMILL

Nut-, Formzirkular- und Trennfräsen

groove milling by circular interpolation, groove and slot milling

Typ Z16

Nutfräsen allgemein

groove milling general use

D min. 16 mm
t max. = 3.5

D min. 16 mm
t max. = 3.5

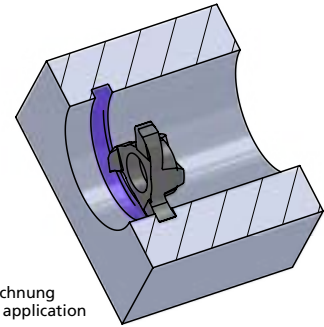
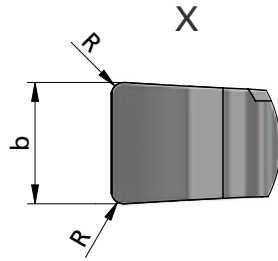
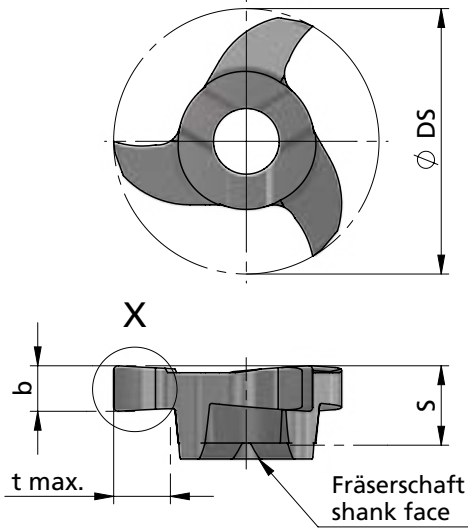

Beispielzeichnung
exemplary application

Abmessungen in mm

dimensions in mm

Bestellnummer part number	D min.	S	R	$\varnothing DS$	b +0.02	b (inch)	t max.	Zähnezahl number of teeth				für Frälerschaft for milling shank
									K10F	AL41F	P18C	
Z16.0117.00	16	4.5	-	15.7	1.17	0.046"	3.5	3	●			
Z16.0150.00	16	4.5	0.2	15.7	1.50		3.5	3	●			
Z16.0157.02	16	4.5	0.2	15.7	1.57	0.062"	3.5	3	●			
Z16.0200.02	16	4.5	0.2	15.7	2.00		3.5	3	●			
Z16.0238.02	16	4.5	0.2	15.7	2.39	0.094"	3.5	3	●			
Z16.0250.02	16	4.5	0.2	15.7	2.50		3.5	3	●			
Z16.0318.02	16	4.5	0.2	15.7	3.18	0.125"	3.5	3	●			

ZH14...

Weitere HM Sorten können Sie in der Sortenübersicht im Kapitel "Technische Hinweise" und der Preisliste finden.

More carbide grades you can find in the grades summary in the chapter "technical instructions" and in the price list.

Bestellbeispiel:
für Sorte AL41F:
Z16.0150.00/AL41F

order-example:
grade AL41F:
Z16.0150.00/AL41F

MINIMILL

Nut-, Formzirkular- und Trennfräsen

groove milling by circular interpolation, groove and slot milling

Typ Z616 / Z616.X

Nutfräsen allgemein

D min. 16 mm
t max. = 3.5

groove milling general use

D min. 16 mm
t max. = 3.5

Z616 geradverzahnt / spur-toothed

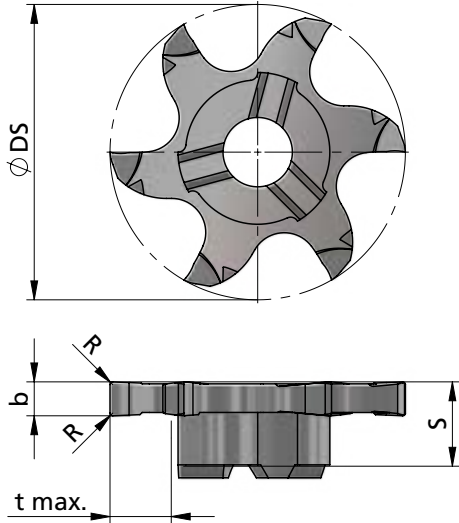

Z616.X kreuzverzahnt / staggered-toothed

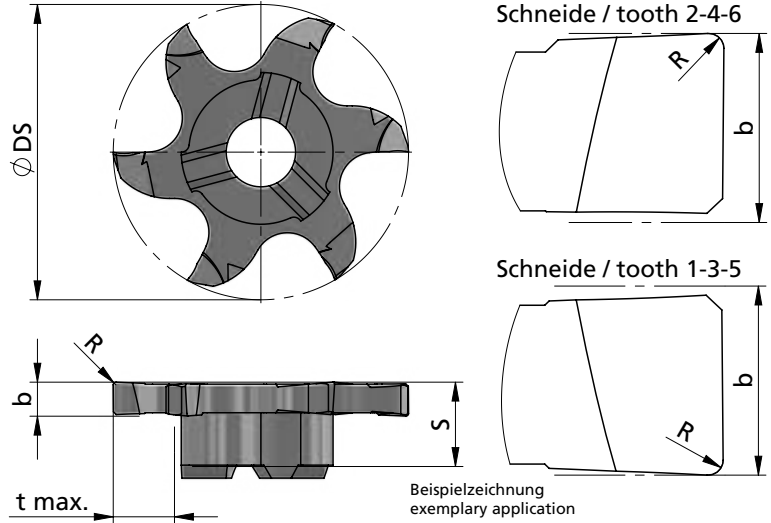

Beispielzeichnung
exemplary application

Abmessungen in mm

dimensions in mm



Bestellnummer part number	D min.	S	R	Ø DS	b +0.02	t max.	Zähnezahl number of teeth	K10F AL41F P18C	für Fräseschaft for milling shank
Z616.0150.02	16	4.5	0.2	15.7	1.5	3.5	6	●	ZH14...
Z616.X150.02	16	4.5	0.2	15.7	1.5	3.5	6	●	
Z616.0200.02	16	4.5	0.2	15.7	2.0	3.5	6	●	
Z616.X200.02	16	4.5	0.2	15.7	2.0	3.5	6	●	
Z616.0250.02	16	4.5	0.2	15.7	2.5	3.5	6	●	
Z616.X250.02	16	4.5	0.2	15.7	2.5	3.5	6	●	

Weitere HM Sorten können Sie in der Sortenübersicht im Kapitel "Technische Hinweise" und der Preisliste finden.

Bestellbeispiel:
für Sorte AL41F:
Z616.X150.02/AL41F

More carbide grades you can find in the grades summary in the chapter "technical instructions" and in the price list.

order-example:
grade AL41F:
Z616.X150.02/AL41F

MINIMILL

Nut-, Formzirkular- und Trennfräsen

groove milling by circular interpolation, groove and slot milling

Typ Z18

Sicherungsringe DIN 471 / 472 und Nutfräsen allgemein

D min. 18 mm
t max. ≤ 3.5

for circlip grooves DIN 471 / 472 and groove milling general use

D min. 18 mm
t max. ≤ 3.5

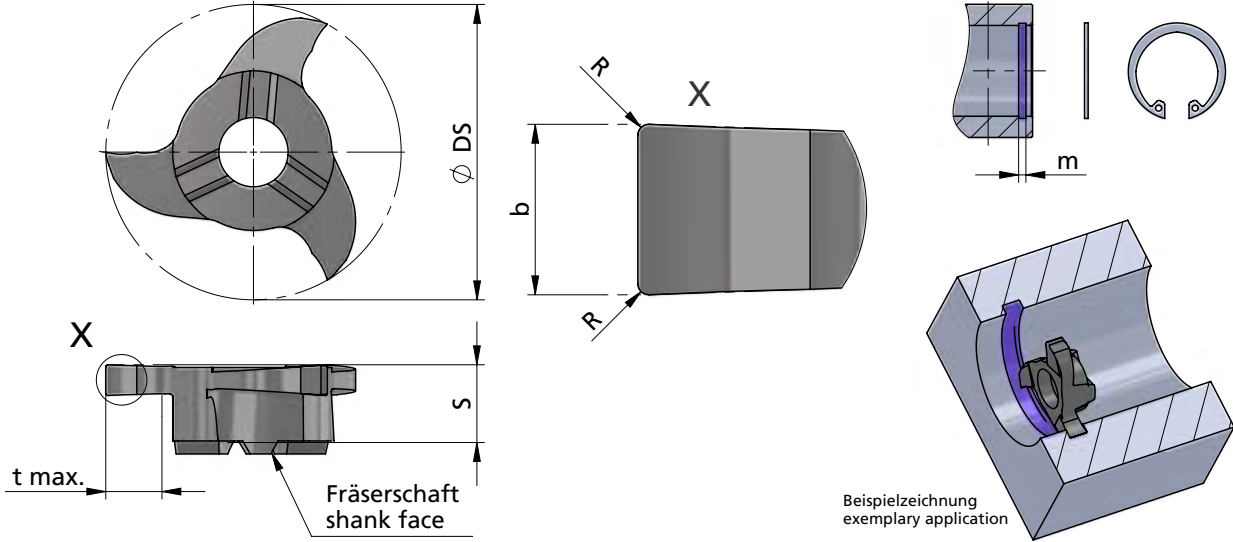

Abmessungen in mm

dimensions in mm

Bestellnummer part number	D min.	Nut-Maß m groove dim. m DIN 471 / DIN 472	S	R	Ø DS	b +0.02 (* b -0.02)	b (inch)	t max.	Zähnezahl number of teeth	K10F	AL41F	P18C	für Fräseschaft for milling shank
Z18.0070.00	18	0.7	5.6	-	17.7	0.74*		1.5	3	●			ZH18...
Z18.0080.00	18	0.8	5.6	-	17.7	0.84*		1.7	3	●			
Z18.0090.00	18	0.9	5.6	-	17.7	0.94*		1.9	3	●			
Z18.0110.00	18	1.1	5.8	-	17.7	1.21*		3.5	3	●			
Z18.0117.00	18	-	5.8	-	17.7	1.17	0.046"	3.5	3	●			
Z18.0130.00	18	1.3	5.8	0.1	17.7	1.41*		3.5	3	●			
Z18.0142.01	18	-	5.8	0.1	17.7	1.42	0.056"	3.5	3	●			
Z18.0150.00	18	-	5.8	0.2	17.7	1.50		3.5	3	●			
Z18.0157.02	18	-	5.8	0.2	17.7	1.57	0.062"	3.5	3	●			
Z18.0160.00	18	1.6	5.8	0.1	17.7	1.71*		3.5	3	●			
↳ ...													

Weitere HM Sorten können Sie in der Sortenübersicht im Kapitel "Technische Hinweise" und der Preisliste finden.

More carbide grades you can find in the grades summary in the chapter "technical instructions" and in the price list.

MINIMILL

Nut-, Formzirkular- und Trennfräsen

groove milling by circular interpolation, groove and slot milling

Typ Z18

Sicherungsringe DIN 471 / 472 und Nutfräsen allgemein

D min. 18 mm
t max. ≤ 3.5

for circlip grooves DIN 471 / 472 and groove milling general use

D min. 18 mm
t max. ≤ 3.5

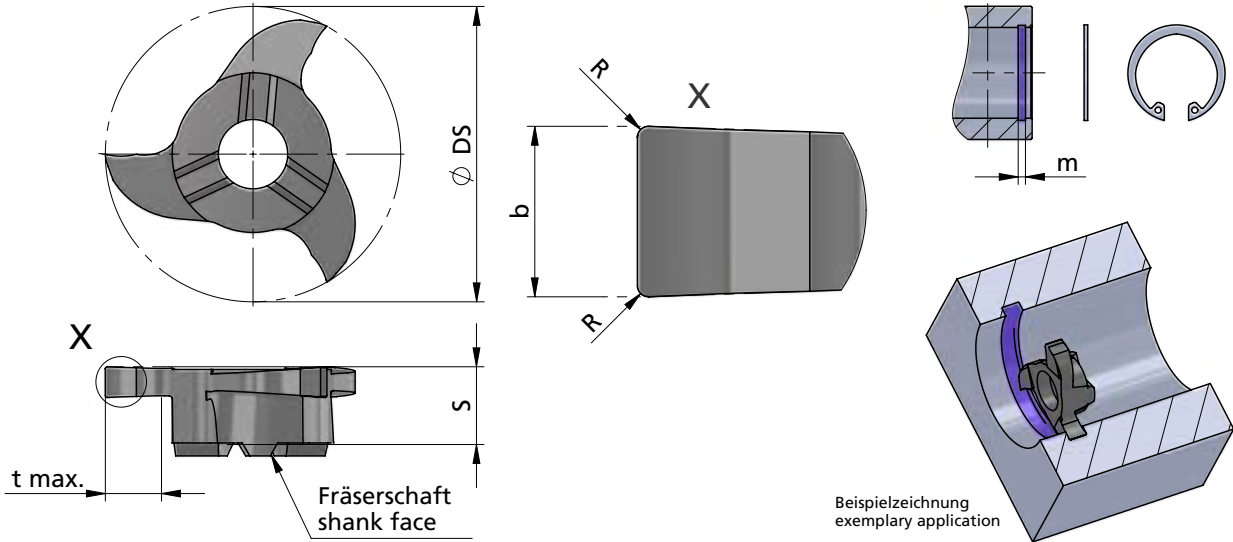

Beispielzeichnung
exemplary application

Abmessungen in mm

dimensions in mm



Bestellnummer part number	D min.	Nut-Maß m groove dim. m DIN 471 / DIN 472	S	R	$\varnothing DS$	b +0.02 (* b -0.02)	b (inch)	t max.	Zähnezahl number of teeth	K10F AL41F P18C	für Fräsertschaft for milling shank
...											
Z18.0198.02	18	-	5.8	0.2	17.7	1.98	0.078"	3.5	3	●	ZH18...
Z18.0200.02	18	-	5.8	0.2	17.7	2.00		3.5	3	●	
Z18.0238.02	18	-	5.8	0.2	17.7	2.39	0.094"	3.5	3	●	
Z18.0250.02	18	-	5.8	0.2	17.7	2.50		3.5	3	●	
Z18.0300.02	18	-	5.8	0.2	17.7	3.00		3.5	3	●	
Z18.0318.02	18	-	5.8	0.2	17.7	3.18	0.125"	3.5	3	●	
Z18.0400.02	18	-	5.8	0.2	17.7	4.00		3.5	3	●	

Weitere HM Sorten können Sie in der Sortenübersicht im Kapitel "Technische Hinweise" und der Preisliste finden.

Bestellbeispiel:
für Sorte AL41F:
Z18.0198.02/AL41F

More carbide grades you can find in the grades summary in the chapter "technical instructions" and in the price list.

order-example:
grade AL41F:
Z18.0198.02/AL41F

MINIMILL

Nut-, Formzirkular- und Trennfräsen

groove milling by circular interpolation, groove and slot milling

Typ Z618

Sicherungsringe DIN 471 / 472

D min. 18 mm
t max. = 4

for circlip grooves DIN 471 / 472

D min. 18 mm
t max. = 4

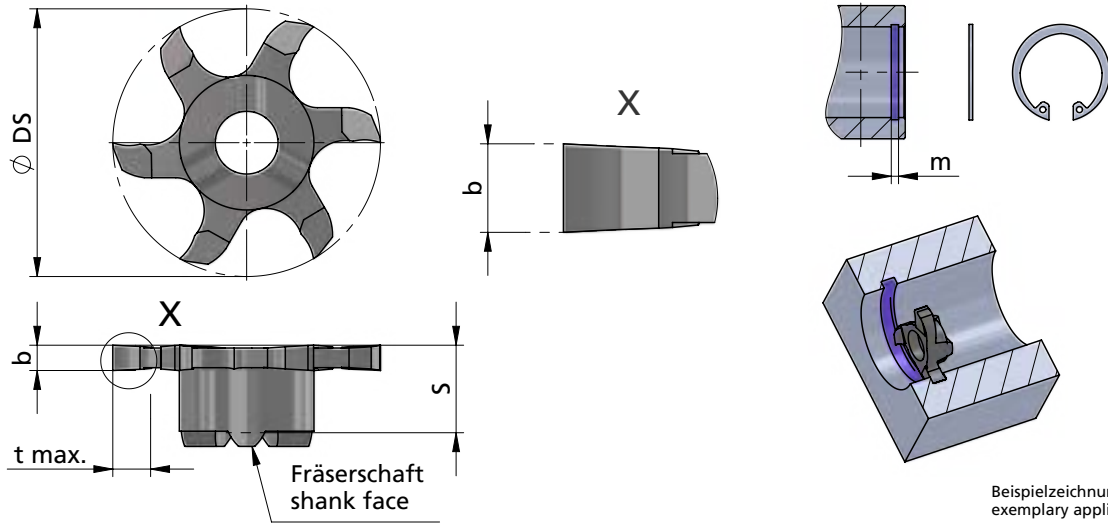

Abmessungen in mm

dimensions in mm

Bestellnummer part number	D min.	Nut-Maß m groove dim. m DIN 471 / DIN 472	S	R	$\varnothing DS$	b -0.02	t max.	Zähnezahl number of teeth				für Fräterschaft for milling shank
									K10F	AL41F	P18C	
Z618.0110.00	18	1.1	5.8	-	17.7	1.21	4	6	●			
Z618.0130.00	18	1.3	5.8	-	17.7	1.41	4	6	●			ZH18...
Z618.0160.00	18	1.6	5.8	-	17.7	1.71	4	6	●			

Weitere HM Sorten können Sie in der Sortenübersicht im Kapitel "Technische Hinweise" und der Preisliste finden.

Bestellbeispiel:
für Sorte AL41F:
Z618.0110.00/AL41F

More carbide grades you can find in the grades summary in the chapter "technical instructions" and in the price list.

order-example:
grade AL41F:
Z618.0110.00/AL41F

MINIMILL

Nut-, Formzirkular- und Trennfräsen

groove milling by circular interpolation, groove and slot milling

Typ Z618 / Z618.X / Z620 / Z620.X

Nutfräsen allgemein

D min. 18 / 20 mm
t max. = 4 / 5

groove milling general use

D min. 18 / 20 mm
t max. = 4 / 5

Z618/Z620 geradverzahnt / spur-toothed

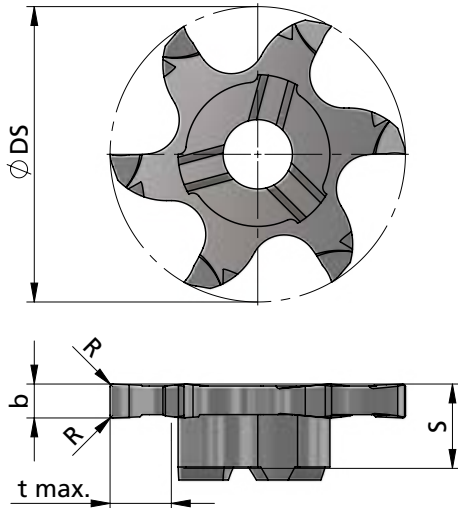

Z618.X/Z620.X kreuzverzahnt / staggered-toothed

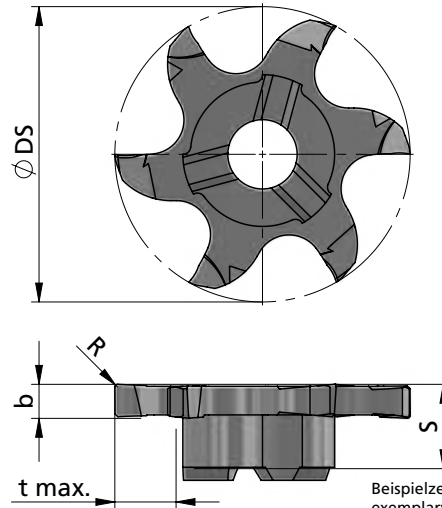

Schneide / tooth 2-4-6

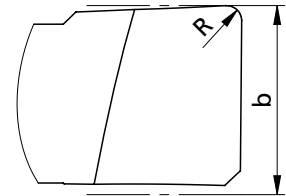

Schneide / tooth 1-3-5

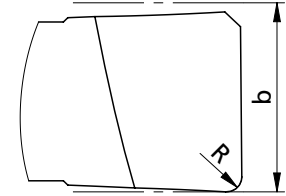

Beispielzeichnung
exemplary application



Abmessungen in mm

dimensions in mm

Bestellnummer part number	D min.	S	R	Ø DS	b +0.02	t max.	Zähnezahl number of teeth	Material			für Fräterschaft for milling shank
								K10F	AL41F	P18C	
Z618.0150.01	18	5.8	0.1	17.7	1.5	4	6	●	●	●	ZH18...
Z618.0200.02	18	5.8	0.2	17.7	2.0	4	6	●	●	●	
Z618.X200.02	18	5.8	0.2	17.7	2.0	4	6	●	●	●	
Z618.0250.02	18	5.8	0.2	17.7	2.5	4	6	●	●	●	
Z618.X250.02	18	5.8	0.2	17.7	2.5	4	6	●	●	●	
Z618.0300.02	18	5.8	0.2	17.7	3.0	4	6	●	●	●	
Z618.X300.02	18	5.8	0.2	17.7	3.0	4	6	●	●	●	
Z620.0150.01	20	5.8	0.1	19.7	1.5	5	6	●	●	●	
Z620.0200.02	20	5.8	0.2	19.7	2.0	5	6	●	●	●	
Z620.X200.02	20	5.8	0.2	19.7	2.0	5	6	●	●	●	
Z620.0250.02	20	5.8	0.2	19.7	2.5	5	6	●	●	●	
Z620.X250.02	20	5.8	0.2	19.7	2.5	5	6	●	●	●	
Z620.0300.02	20	5.8	0.2	19.7	3.0	5	6	●	●	●	
Z620.X300.02	20	5.8	0.2	19.7	3.0	5	6	●	●	●	

Weitere HM Sorten können Sie in der Sortenübersicht im Kapitel "Technische Hinweise" und der Preisliste finden.

Bestellbeispiel:
für Sorte AL41F:
Z618.0150.01/AL41F

More carbide grades you can find in the grades summary in the chapter "technical instructions" and in the price list.

order-example:
grade AL41F:
Z618.0150.01/AL41F

MINIMILL

Nut-, Formzirkular- und Trennfräsen

groove milling by circular interpolation, groove and slot milling

Typ Z22

Sicherungsringe DIN 471 / 472 und Nutfräsen allgemein

D min. 22 mm
t max. ≤ 4.5

for circlip grooves DIN 471 / 472 and groove milling general use

D min. 22 mm
t max. ≤ 4.5

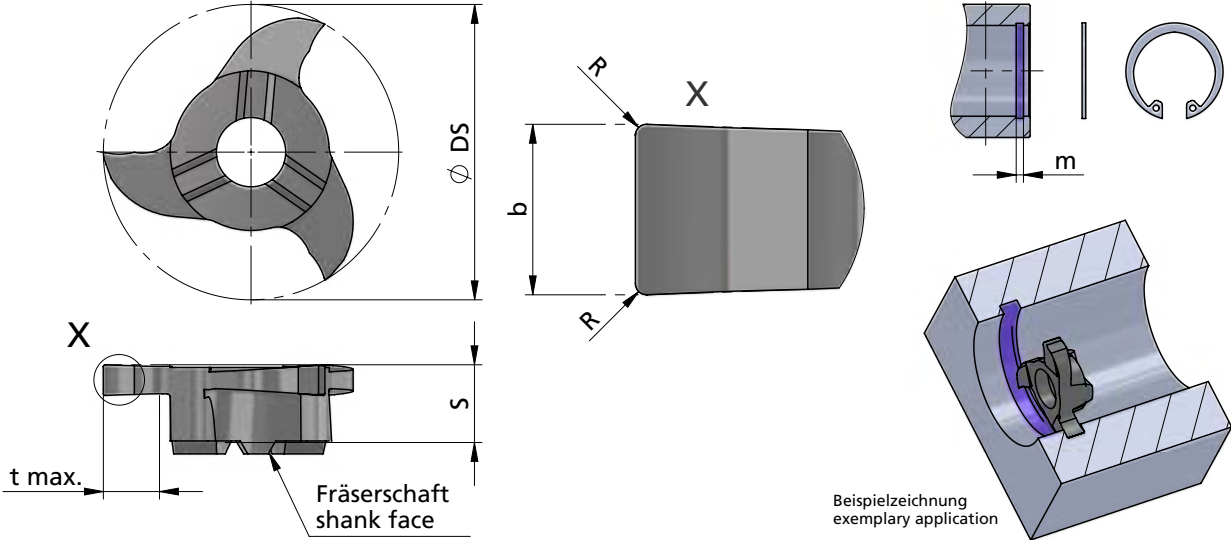

Beispielzeichnung
exemplary application

Abmessungen in mm

dimensions in mm

Bestellnummer part number	D min.	Nut-Maß m groove dim. m DIN 471 / DIN 472	S	R	Ø DS	b +0.02 (* b -0.02)	b (inch)	t max.	Zähnezahl number of teeth	K10F	AL41F	P18C	für Frärschaft for milling shank
Z22.0070.00	22	0.7	5.6	-	21.7	0.74*		1.5	3	●			ZH22...
Z22.0079.00	22	-	5.6	-	21.7	0.79	0.031"	1.5	3	●			
Z22.0080.00	22	0.8	5.6	-	21.7	0.84*		1.7	3	●			
Z22.0090.00	22	0.9	5.6	-	21.7	0.94*		1.9	3	●			
Z22.0099.00	22	-	5.6	-	21.7	0.99	0.039"	2.0	3	●			
Z22.0100.00	22	1.0	5.6	-	21.7	1.04*		2.1	3	●			
Z22.0100.01	22	-	5.6	0.10	21.7	1.00		4.5	3	●			
Z22.0110.00	22	1.1	5.7	-	21.7	1.21*		2.5	3	●			
Z22.0117.00	22	-	5.7	-	21.7	1.17	0.046"	2.5	3	●			
Z22.0130.00	22	1.3	5.7	0.10	21.7	1.41*		4.5	3	●			
Z22.0142.01	22	-	5.7	0.10	21.7	1.42	0.056"	4.5	3	●			
Z22.0150.02	22	-	5.7	0.20	21.7	1.50		4.5	3	●			
Z22.0160.00	22	1.6	5.7	0.10	21.7	1.71*		4.5	3	●			
Z22.0185.02	22	1.85	5.7	0.20	21.7	1.96*		4.5	3	●			
↳ ...													

Weitere HM Sorten können Sie in der Sortenübersicht im Kapitel "Technische Hinweise" und der Preisliste finden.

More carbide grades you can find in the grades summary in the chapter "technical instructions" and in the price list.

MINIMILL

Nut-, Formzirkular- und Trennfräsen

groove milling by circular interpolation, groove and slot milling

Typ Z22

Sicherungsringe DIN 471 / 472 und Nutfräsen allgemein

D min. 22 mm
t max. ≤ 4.5

for circlip grooves DIN 471 / 472 and groove milling general use

D min. 22 mm
t max. ≤ 4.5

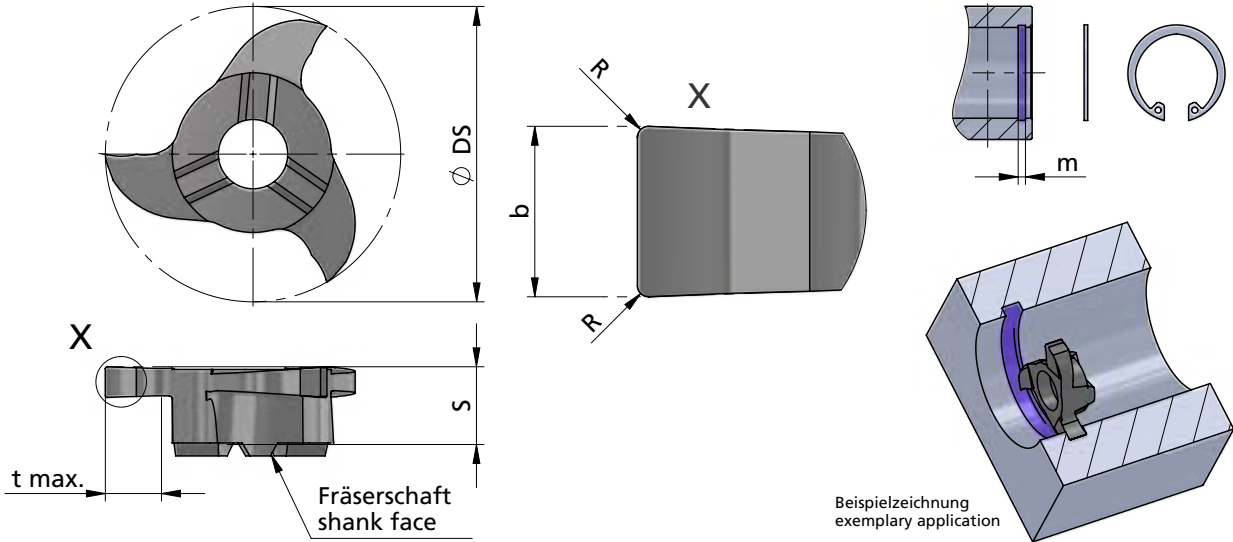

Abmessungen in mm

dimensions in mm



Bestellnummer part number	D min.	Nut-Maß m groove dim. m DIN 471 / DIN 472	S	R	Ø DS	b +0.02 (* b -0.02)	b (inch)	t max.	Zähnezahl number of teeth	Material			für Fräterschaft for milling shank
										K10F	AL41F	P18C	
...													
Z22.0198.02	22	-	5.7	0.20	21.7	1.98	0.078"	4.5	3	●			ZH22...
Z22.0200.02	22	-	5.7	0.20	21.7	2.00		4.5	3	●			
Z22.0215.02	22	2.15	5.7	0.20	21.7	2.26*		4.5	3	●			
Z22.0238.02	22	-	5.7	0.20	21.7	2.39	0.094"	4.5	3	●			
Z22.0250.02	22	-	5.7	0.20	21.7	2.50		4.5	3	●			
Z22.0265.02	22	2.65	5.7	0.20	21.7	2.76*		4.5	3	●			
Z22.0300.02	22	-	5.7	0.20	21.7	3.00		4.5	3	●			
Z22.0315.02	22	3.15	5.7	0.20	21.7	3.26*		4.5	3	●			
Z22.0350.02	22	-	5.7	0.20	21.7	3.50		4.5	3	●			
Z22.0400.02	22	-	5.7	0.20	21.7	4.00		4.5	3	●			
Z22.0415.02	22	4.15	5.7	0.20	21.7	4.26*		4.5	3	●			
Z22.0475.02	22	-	5.7	0.20	21.7	4.75	0.187"	4.5	3	●			
Z22.0500.02	22	-	5.7	0.20	21.7	5.00		4.5	3	●			
Z22.0515.02	22	5.15	5.7	0.20	21.7	5.26*		4.5	3	●			

Weitere HM Sorten können Sie in der Sortenübersicht im Kapitel "Technische Hinweise" und der Preisliste finden.

Bestellbeispiel:
für Sorte AL41F:
Z22.0515.02/AL41F

More carbide grades you can find in the grades summary in the chapter "technical instructions" and in the price list.

order-example:
grade AL41F:
Z22.0515.02/AL41F

MINIMILL

Nut-, Formzirkular- und Trennfräsen

groove milling by circular interpolation, groove and slot milling

Typ Z22

Sicherungsringe, DIN 471 / 472 mit Nutaußenkantenfasung

D min. 22 mm

for circlip grooves DIN 471 / 472 with chamfer

D min. 22 mm

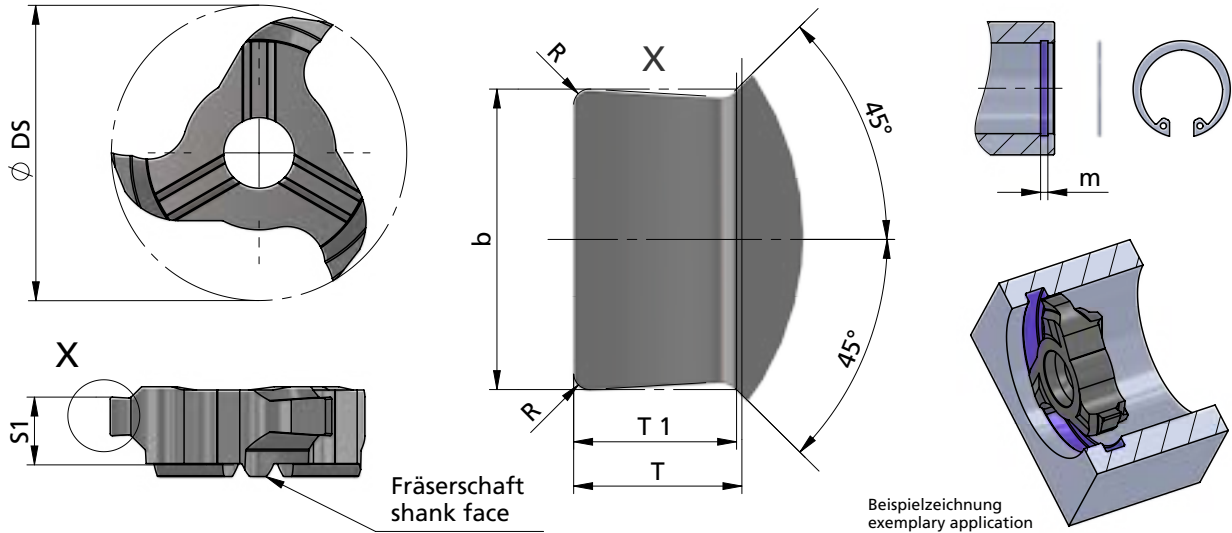

Abmessungen in mm

dimensions in mm

Bestellnummer part number	D min.	Nut-Maß m groove dim. m DIN 471 / DIN 472	S1	R	Ø DS	b -0.02	T1 -0.04 Formtiefe depth of form	T	Zähnezahl number of teeth	K10F	AL41F	P18C	für Frärschaft for milling shank
Z22.1105.30	22	1.1	5.0	-	21.7	1.21	0.49	0.50	3	●			ZH22... ZH28...
Z22.1307.30	22	1.3	5.2	-	21.7	1.41	0.67	0.70	3	●			
Z22.1308.30	22	1.3	5.2	-	21.7	1.41	0.83	0.85	3	●			
Z22.1609.35	22	1.6	5.0	-	21.7	1.71	0.83	0.85	3	●			
Z22.1610.35	22	1.6	5.0	-	21.7	1.71	0.95	1.00	3	●			
Z22.1812.35	22	1.85	5.2	0.15	21.7	1.96	1.23	1.25	3	●			
Z22.2215.35	22	2.15	5.3	0.15	21.7	2.26	1.47	1.50	3	●			
Z22.2616.45	22	2.65	5.0	0.15	21.7	2.76	1.47	1.50	3	●			
Z22.2617.45	22	2.65	5.0	0.15	21.7	2.76	1.72	1.75	3	●			
Z22.3118.45	22	3.15	5.3	0.2	21.7	3.26	1.72	1.75	3	●			
Z22.4120.55	22	4.15	5.3	0.2	21.7	4.26	1.97	2.00	3	●			
Z22.4125.55	22	4.15	5.3	0.2	21.7	4.26	2.47	2.50	3	●			

Weitere HM Sorten können Sie in der Sortenübersicht im Kapitel "Technische Hinweise" und der Preisliste finden.

Bestellbeispiel:
für Sorte AL41F:
Z22.4125.55/AL41F

More carbide grades you can find in the grades summary in the chapter "technical instructions" and in the price list.

order-example:
grade AL41F:
Z22.4125.55/AL41F

MINIMILL

Nut-, Formzirkular- und Trennfräsen

groove milling by circular interpolation, groove and slot milling

Typ Z622 / Z622.X

Nutfräsen allgemein

D min. 22 mm
t max. = 4.5

groove milling general use

D min. 22 mm
t max. = 4.5



Z622 geradverzahnt / spur-toothed

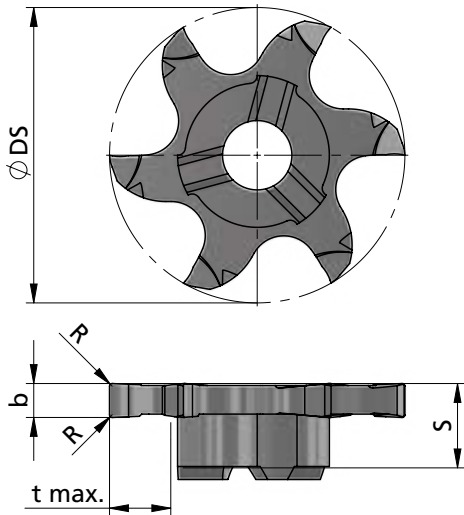

Z622.X kreuzverzahnt / staggered-toothed

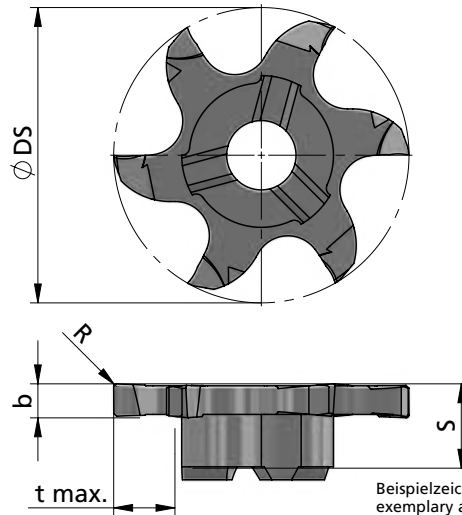

Schneide / tooth 2-4-6

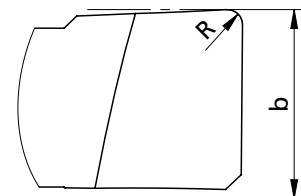

Schneide / tooth 1-3-5

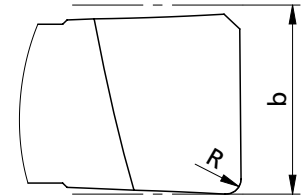

Beispielzeichnung
exemplary application



Abmessungen in mm

dimensions in mm

Bestellnummer part number	D min.	S	R	Ø DS	b +0.02	b (inch)	t max.	Zähnezahl number of teeth	K10F AL41F P18C	für Fräseschaft for milling shank
Z622.0100.01	22	5.8	0.1	21.7	1.00		4.5	6	●	ZH22...
Z622.0117.01	22	6.0	0.1	21.7	1.17	0.046"	4.5	6	●	
Z622.0150.01	22	6.2	0.1	21.7	1.50		4.5	6	●	
Z622.0157.01	22	6.2	0.1	21.7	1.57	0.062"	4.5	6	●	
Z622.0200.02	22	6.2	0.2	21.7	2.00		4.5	6	●	
Z622.X200.02	22	6.2	0.2	21.7	2.00		4.5	6	●	
Z622.0238.02	22	6.2	0.2	21.7	2.38	0.094"	4.5	6	●	
Z622.0250.02	22	6.2	0.2	21.7	2.50		4.5	6	●	
Z622.X250.02	22	6.2	0.2	21.7	2.50		4.5	6	●	
Z622.0300.02	22	6.2	0.2	21.7	3.00		4.5	6	●	
Z622.X300.02	22	6.2	0.2	21.7	3.00		4.5	6	●	
Z622.0318.02	22	5.5	0.2	21.7	3.18	0.125"	4.5	6	●	
Z622.0400.02	22	6.2	0.2	21.7	4.00		4.5	6	●	
Z622.X400.02	22	6.2	0.2	21.7	4.00		4.5	6	●	

Weitere HM Sorten können Sie in der Sortenübersicht im Kapitel "Technische Hinweise" und der Preisliste finden.

Bestellbeispiel:
für Sorte AL41F:
Z622.0100.01/AL41F

More carbide grades you can find in the grades summary in the chapter "technical instructions" and in the price list.

order-example:
grade AL41F:
Z622.0100.01/AL41F

MINIMILL

Nut-, Formzirkular- und
Trennfräsen

groove milling by
circular interpolation,
groove and slot milling

Typ Z922

Nutfräsen allgemein

Ø DS. 22 mm
t max. = 4.5

groove milling general use

Ø DS. 22 mm
t max. = 4.5

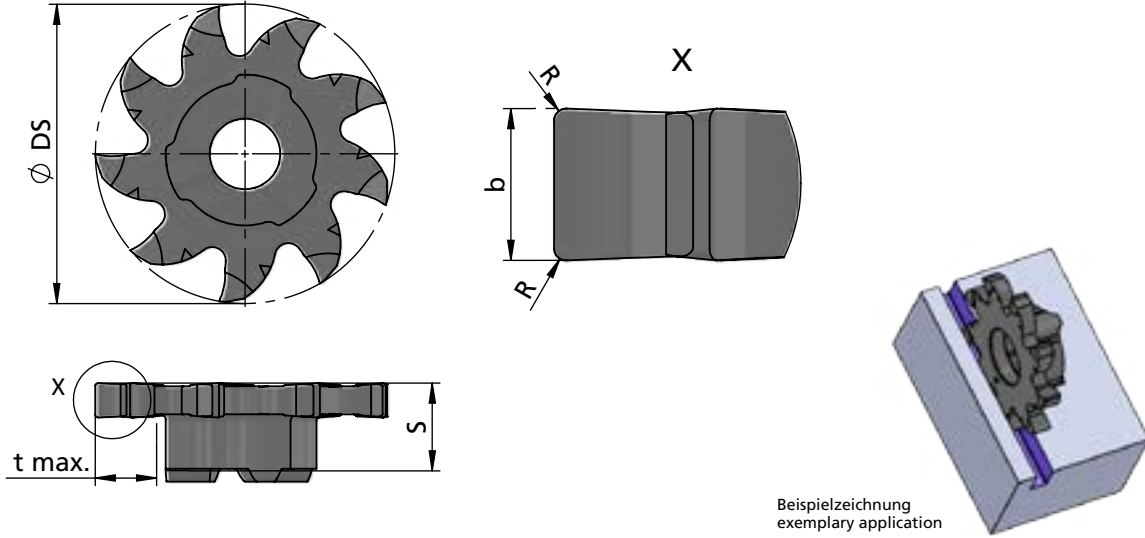

Abmessungen in mm

dimensions in mm

Bestellnummer part number	S	R	Ø DS	b +0.02	t max.	Zähnezahl number of teeth				für Fräterschaft for milling shank
							K10F	AL41F	P04C	
Z922.0150.01	6.4	0.1	22	1.5	4.5	9			●	ZH22...
Z922.0200.02	6.4	0.2	22	2.0	4.5	9			●	
Z922.0250.02	6.4	0.2	22	2.5	4.5	9			●	
Z922.0300.02	6.4	0.2	22	3.0	4.5	9			●	

Weitere HM Sorten können Sie in der Sorten-
übersicht im Kapitel "Technische Hinweise" und
der Preisliste finden.

Bestellbeispiel:
für Sorte P04C:
Z922.0150.01/P04C

More carbide grades you can find in the grades
summary in the chapter "technical instructions"
and in the price list.

order-example:
grade P04C:
Z922.0150.01/P04C

MINIMILL

Nut-, Formzirkular- und Trennfräsen

groove milling by circular interpolation, groove and slot milling

Typ Z25

Nutfräsen allgemein

D min. 25 mm
t max. = 5.0

groove milling general use

D min. 25 mm
t max. = 5.0

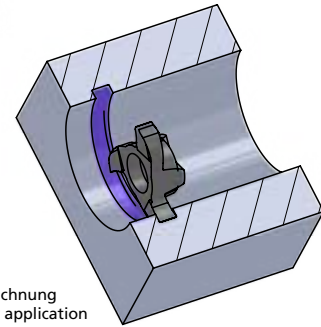
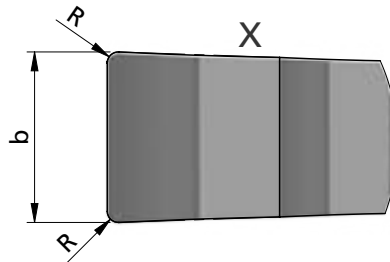
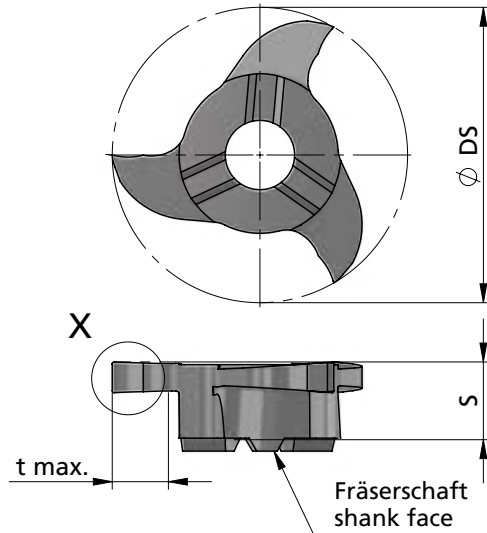

Beispielzeichnung
exemplary application

Abmessungen in mm

dimensions in mm



Bestellnummer part number	Abmessungen in mm								dimensions in mm			für Fräterschaft for milling shank
	D min.	S	R	Ø DS	b +0.02	b (inch)	t max.	Zähnezahl number of teeth	K10F	AL41F	P18C	
Z25.0200.02	25	6.6	0.2	24.8	2.00		5.0	3	●			ZH28...
Z25.0250.02	25	6.6	0.2	24.8	2.50		5.0	3	●			
Z25.0300.02	25	6.6	0.2	24.8	3.00		5.0	3	●			
Z25.0318.02	25	6.6	0.2	24.8	3.18	0.125"	5.0	3	●			
Z25.0350.02	25	6.6	0.2	24.8	3.50		5.0	3	●			
Z25.0400.02	25	6.6	0.2	24.8	4.00		5.0	3	●			

Weitere HM Sorten können Sie in der Sortenübersicht im Kapitel "Technische Hinweise" und der Preisliste finden.

Bestellbeispiel:
für Sorte AL41F:
Z25.0350.02/AL41F

More carbide grades you can find in the grades summary in the chapter "technical instructions" and in the price list.

order-example:
grade AL41F:
Z25.0350.02/AL41F

MINIMILL

Nut-, Formzirkular- und
Trennfräsen

groove milling by
circular interpolation,
groove and slot milling

Typ Z625.X

Nutfräsen allgemein

groove milling general use

D min. 25 mm
t max. = 5

D min. 25 mm
t max. = 5

Z625.X kreuzverzahnt / staggered-toothed

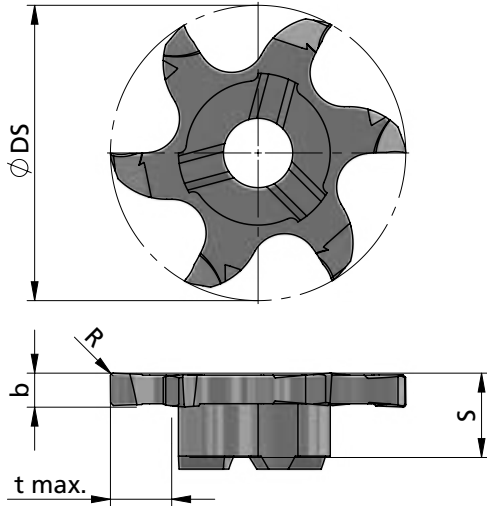

Schneide / tooth 2-4-6

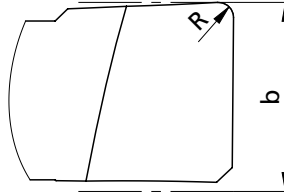

Schneide / tooth 1-3-5

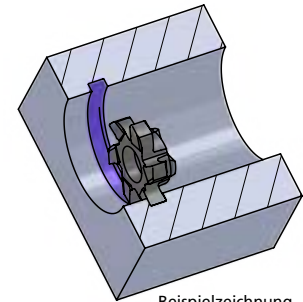
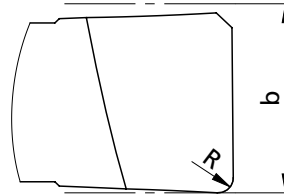

Beispielzeichnung
exemplary application

Abmessungen in mm

dimensions in mm

Bestellnummer part number	D min.	S	R	Ø DS	b +0.02	t max.	Zähnezahl number of teeth				für Fräterschaft for milling shank
								K10F	AL41F	P18C	
Z625.X250.02	25	6.4	0.2	24.8	2.5	5.0	6	●			
Z625.X300.02	25	6.4	0.2	24.8	3.0	5.0	6	●			
Z625.X400.02	25	6.4	0.2	24.8	4.0	5.0	6	●			ZH28...
Z625.X500.02	25	6.4	0.2	24.8	5.0	5.0	6	●			
Z625.X600.02	25	6.4	0.2	24.8	6.0	5.0	6	●			

Weitere HM Sorten können Sie in der Sorten-
übersicht im Kapitel "Technische Hinweise" und
der Preisliste finden.

Bestellbeispiel:
für Sorte AL41F:
Z625.X250.02/AL41F

More carbide grades you can find in the grades
summary in the chapter "technical instructions"
and in the price list.

order-example:
grade AL41F:
Z625.X250.02/AL41F

MINIMILL

Nut-, Formzirkular- und Trennfräsen

groove milling by circular interpolation, groove and slot milling

Typ Z28

Nutfräsen allgemein

D min. 28 mm
t max. = 6.5

groove milling general use

D min. 28 mm
t max. = 6.5

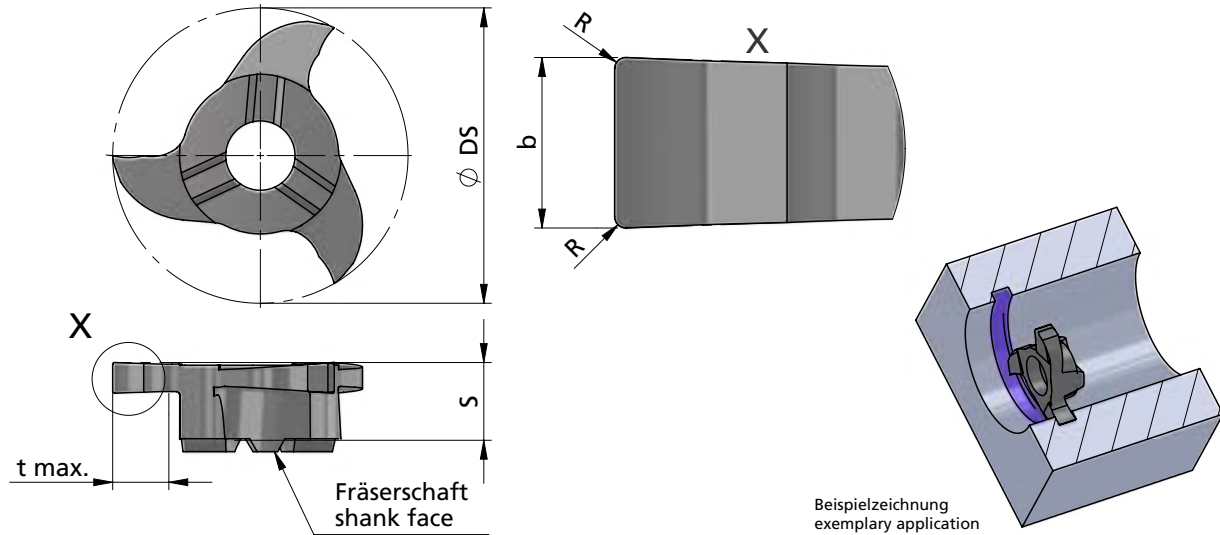

Beispielzeichnung
exemplary application

Abmessungen in mm

dimensions in mm



Bestellnummer part number	dimensions in mm								material			für Fräterschaft for milling shank
	D min.	S	R	ϕDS	b +0.02	b (inch)	t max.	Zähnezahl number of teeth	K10F	AL41F	P18C	
Z28.0150.00	28	6.6	0.2	27.7	1.50		6.5	3	●			ZH28...
Z28.0200.02	28	6.6	0.2	27.7	2.00		6.5	3	●			
Z28.0238.02	28	6.6	0.2	27.7	2.39	0.094"	6.5	3	●			
Z28.0250.02	28	6.6	0.2	27.7	2.50		6.5	3	●			
Z28.0300.02	28	6.6	0.2	27.7	3.00		6.5	3	●			
Z28.0318.02	28	6.6	0.2	27.7	3.18	0.125"	6.5	3	●			
Z28.0350.02	28	6.6	0.2	27.7	3.50		6.5	3	●			
Z28.0400.02	28	6.6	0.2	27.7	4.00		6.5	3	●			
Z28.0475.02	28	6.6	0.2	27.7	4.75	0.187"	6.5	3	●			
Z28.0500.02	28	6.6	0.2	27.7	5.00		6.5	3	●			
Z28.0600.02	28	6.6	0.2	27.7	6.00		6.5	3	●			

Weitere HM Sorten können Sie in der Sortenübersicht im Kapitel "Technische Hinweise" und der Preisliste finden.

Bestellbeispiel:
für Sorte AL41F:
Z28.0350.02/AL41F

More carbide grades you can find in the grades summary in the chapter "technical instructions" and in the price list.

order-example:
grade AL41F:
Z28.0350.02/AL41F

MINIMILL

Nut-, Formzirkular- und Trennfräsen

groove milling by circular interpolation, groove and slot milling

Typ Z28

Nutfräsen allgemein

groove milling general use

D min. 28.3 mm
t max. = 9.3

D min. 28.3 mm
t max. = 9.3

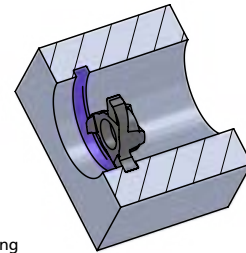
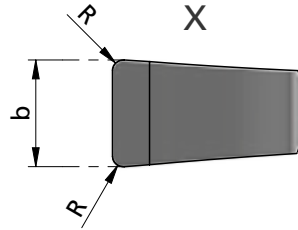
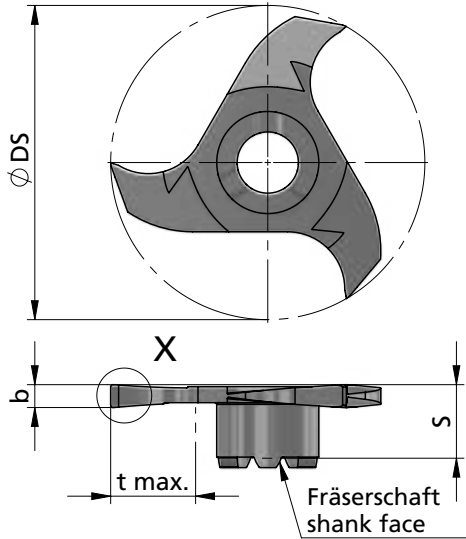

Beispielzeichnung
exemplary application

Abmessungen in mm

dimensions in mm

Bestellnummer part number	D min.	S	R	Ø DS	b -0.02	t max.	Zähnezahl number of teeth	Material			für Fräferschaft for milling shank
								K10F	AL41F	P18C	
Z28.0150.02.9	28.3	6.5	0.2	28	1.5	9.3	3	●			
Z28.0200.02.9	28.3	6.5	0.2	28	2.0	9.3	3		●		ZH33...
Z28.0250.02.9	28.3	6.5	0.2	28	2.5	9.3	3		●		

Weitere HM Sorten können Sie in der Sortenübersicht im Kapitel "Technische Hinweise" und der Preisliste finden.

Bestellbeispiel:
für Sorte AL41F:
Z28.0150.02.9/AL41F

More carbide grades you can find in the grades summary in the chapter "technical instructions" and in the price list.

order-example:
grade AL41F:
Z28.0150.02.9/AL41F

MINIMILL

Nut-, Formzirkular- und Trennfräsen

groove milling by circular interpolation, groove and slot milling

Typ Z628 / Z628.X

Sicherungsringe DIN 471 / 472 und Nutfräsen allgemein

D min. 28 mm
t max. = 6.5

for circlip grooves DIN 471 / 472 and groove milling general use

D min. 28 mm
t max. = 6.5

Z628 geradverzahnt / spur-toothed

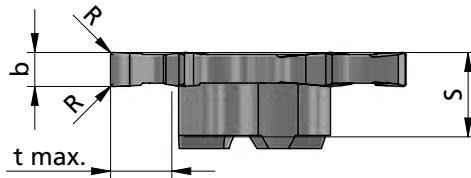
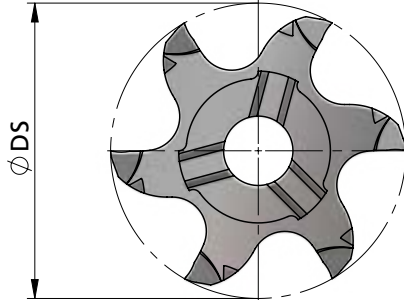

Z628.X kreuzverzahnt / staggered-toothed

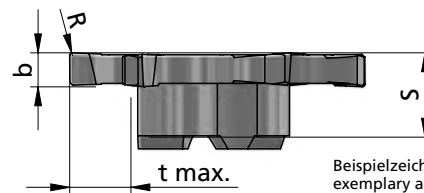
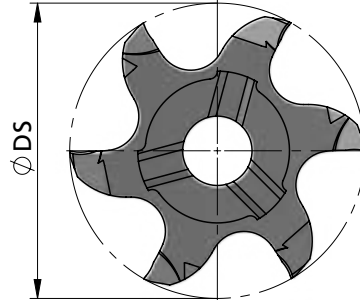

Beispielzeichnung
exemplary application

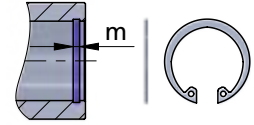

Schneide / tooth 2-4-6

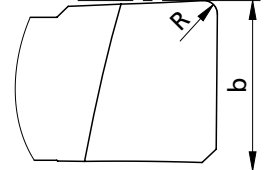

Schneide / tooth 1-3-5

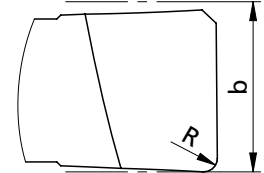

Abmessungen in mm

dimensions in mm

Bestellnummer part number	D min.	Nut-Maß m groove dim. m DIN 471 / DIN 472	S	R	Ø DS	b +0.02 (* b -0.02)	t max.	Zähnezahl number of teeth	K10F AL41F P18C	für Fräterschaft for milling shank
Z628.0100.01	28	-	6.0	0.1	27.7	1.00	6.5	6	●	ZH28...
Z628.0150.01	28	-	6.4	0.1	27.7	1.50	6.5	6	●	
Z628.0185.02	28	1.85	6.4	0.15	27.7	1.96 *	6.5	6	●	
Z628.0200.02	28	-	6.4	0.2	27.7	2.00	6.5	6	●	
Z628.0215.02	28	2.15	6.2	0.15	27.7	2.26 *	6.5	6	●	
Z628.0250.02	28	-	6.4	0.2	27.7	2.50	6.5	6	●	
Z628.X250.02	28	-	6.2	0.2	27.7	2.50	6.5	6	●	
Z628.0300.02	28	-	6.4	0.2	27.7	3.00	6.5	6	●	
Z628.X300.02	28	-	6.2	0.2	27.7	3.00	6.5	6	●	
Z628.0400.02	28	-	6.4	0.2	27.7	4.00	6.5	6	●	
Z628.X400.02	28	-	6.2	0.2	27.7	4.00	6.5	6	●	
Z628.0500.02	28	-	6.4	0.2	27.7	5.00	6.5	6	●	
Z628.X500.02	28	-	6.2	0.2	27.7	5.00	6.5	6	●	
Z628.0600.02	28	-	6.4	0.2	27.7	6.00	6.5	6	●	
Z628.X600.02	28	-	6.2	0.2	27.7	6.00	6.5	6	●	

Weitere HM Sorten können Sie in der Sortenübersicht im Kapitel "Technische Hinweise" und der Preisliste finden.

Bestellbeispiel:
für Sorte AL41F: Z628.0150.01/AL41F

More carbide grades you can find in the grades summary in the chapter "technical instructions" and in the price list.

order-example:
grade AL41F: Z628.0150.01/AL41F

MINIMILL

Nut-, Formzirkular- und
Trennfräsen

groove milling by
circular interpolation,
groove and slot milling

Typ Z628

Nutfräsen allgemein

D min. 28.3 mm
t max. = 9.3

groove milling general use

D min. 28.3 mm
t max. = 9.3

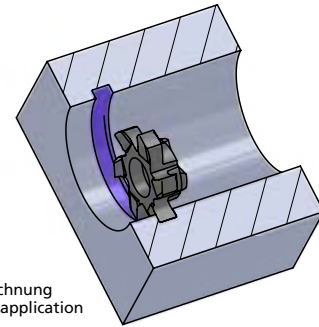
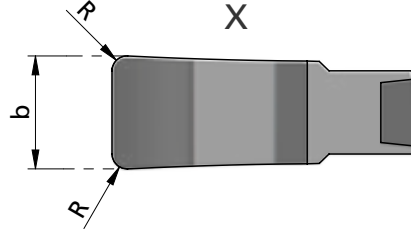
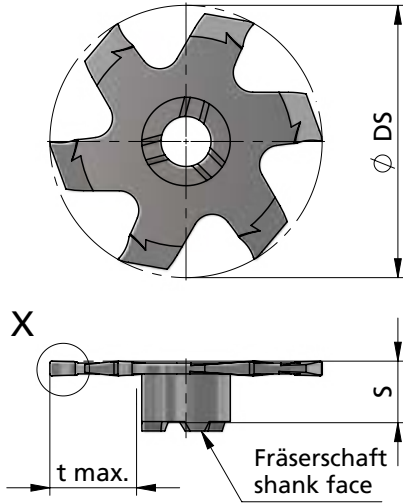

Beispielzeichnung
exemplary application

Abmessungen in mm

dimensions in mm

Bestellnummer part number	D min.	S	R	Ø DS	b +0.02	t max.	Zähnezahl number of teeth	K10F AL41F P18C	für Fräseschaft for milling shank
Z628.120.02.9	28.3	6.2	0.2	28	1.2	9.3	6	●	
Z628.150.02.9	28.3	6.2	0.2	28	1.5	9.3	6	●	ZH33...
Z628.200.02.9	28.3	6.2	0.2	28	2.0	9.3	6	●	

Weitere HM Sorten können Sie in der Sorten-
übersicht im Kapitel "Technische Hinweise" und
der Preisliste finden.

Bestellbeispiel:
für Sorte AL41F:
Z628.150.02.9/AL41F

More carbide grades you can find in the grades
summary in the chapter "technical instructions"
and in the price list.

order-example:
grade AL41F:
Z628.150.02.9/AL41F

MINIMILL

Nut-, Formzirkular- und Trennfräsen

groove milling by circular interpolation, groove and slot milling

Typ Z928

Nutfräsen allgemein

Ø DS. 28 mm
t max. = 6.5

groove milling general use

Ø DS. 28 mm
t max. = 6.5

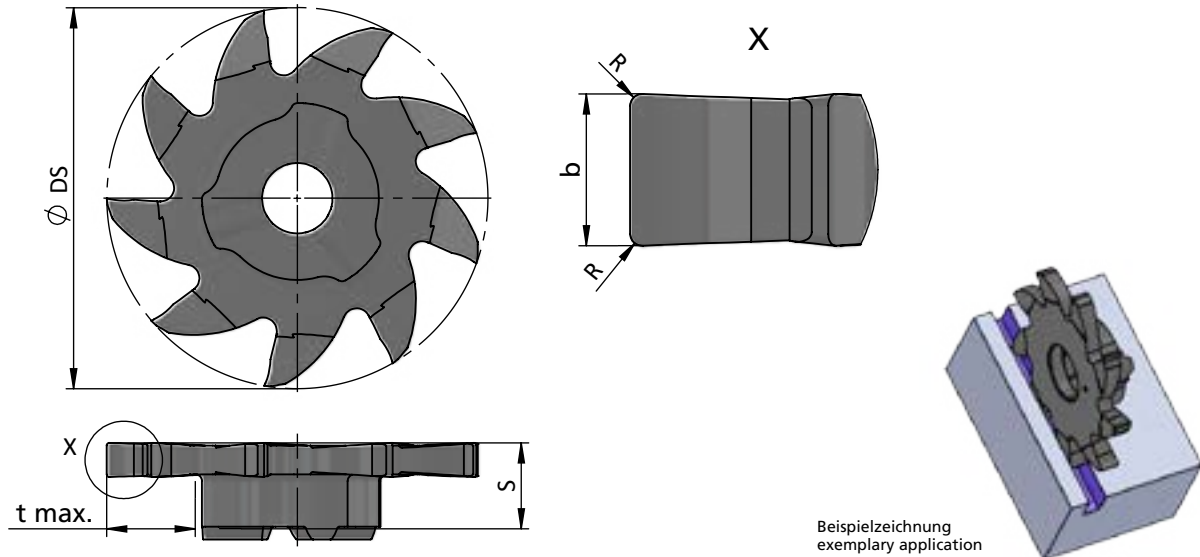

Abmessungen in mm

dimensions in mm



Bestellnummer part number	S	R	Ø DS	b +0.02	t max.	Zähnezahl number of teeth				für Fräseschaft for milling shank
							K10F	AL41F	P04C	
Z928.0150.01	6.3	0.1	28	1.5	6.5	9			●	ZH28...
Z928.0200.02	6.3	0.2	28	2.0	6.5	9			●	
Z928.0250.02	6.3	0.2	28	2.5	6.5	9			●	
Z928.0300.02	6.3	0.2	28	3.0	6.5	9			●	

Weitere HM Sorten können Sie in der Sortenübersicht im Kapitel "Technische Hinweise" und der Preisliste finden.

Bestellbeispiel:
für Sorte P04C:
Z928.0150.01/P04C

More carbide grades you can find in the grades summary in the chapter "technical instructions" and in the price list.

order-example:
grade P04C:
Z928.0150.01/P04C

MINIMILL

Nut-, Formzirkular- und Trennfräsen

groove milling by circular interpolation, groove and slot milling

Typ Z32

Nutfräsen allgemein

groove milling general use

D min. 32 mm
t max. = 8.5

D min. 32 mm
t max. = 8.5

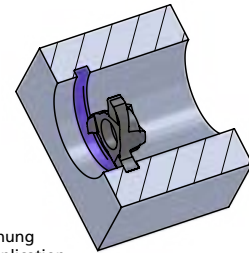
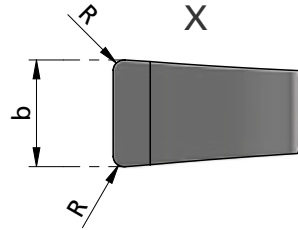
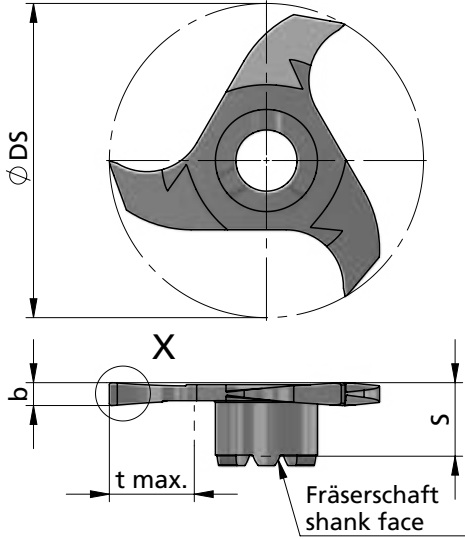

Beispielzeichnung
exemplary application

Abmessungen in mm

dimensions in mm

Bestellnummer part number	Abmessungen in mm / dimensions in mm							Zähnezahl number of teeth	Material			für Fräaserschaft for milling shank
	D min.	S	R	$\varnothing DS$	b +0.02	t max.	K10F		AL41F	P18C		
Z32.0200.00	32	6.5	0.2	31.7	2.0	8.5	3	●				
Z32.0250.02	32	6.5	0.2	31.7	2.5	8.5	3		●		ZH28...	
Z32.0300.02	32	6.5	0.2	31.7	3.0	8.5	3			●		

Weitere HM Sorten können Sie in der Sortenübersicht im Kapitel "Technische Hinweise" und der Preisliste finden.

Bestellbeispiel:
für Sorte AL41F:
Z32.0300.02/AL41F

More carbide grades you can find in the grades summary in the chapter "technical instructions" and in the price list.

order-example:
grade AL41F:
Z32.0300.02/AL41F

MINIMILL

Nut-, Formzirkular- und Trennfräsen

groove milling by circular interpolation, groove and slot milling

Typ Z33

Nutfräsen allgemein

groove milling general use

D min. 33 / 33.9 mm
t max. = 10 / 12

D min. 33 / 33.9 mm
t max. = 10 / 12

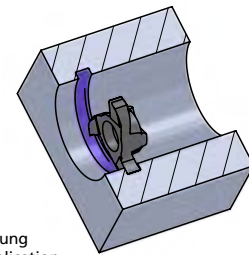
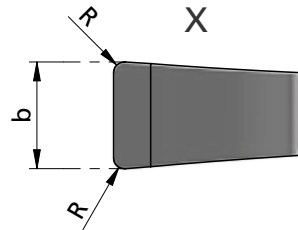
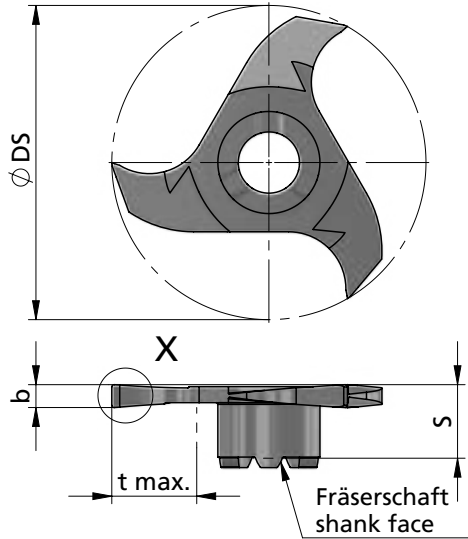

Beispielzeichnung
exemplary application

Abmessungen in mm

dimensions in mm



Bestellnummer part number	D min.	S	R	Ø DS	b -0.02	t max.	Zähnezahl number of teeth				für Fräferschaft for milling shank
								K10F	AL41F	P18C	
Z33.110.42.10	33	6.5	0.2	32.7	1.10	10	3	●			ZH22...
Z33.120.42.10	33	6.5	0.2	32.7	1.20	10	3	●			
Z33.132.42.10	33	6.5	0.2	32.7	1.32	10	3	●			
Z33.150.42.10	33	6.5	0.2	32.7	1.50	10	3	●			
Z33.160.42.10	33	6.5	0.2	32.7	1.60	10	3	●			
Z33.170.42.10	33	6.5	0.2	32.7	1.70	10	3	●			
Z33.200.42.10	33	6.5	0.2	32.7	2.00	10	3	●			
Z33.250.42.10	33	6.5	0.2	32.7	2.50	10	3	●			
Z33.170.42.12	33.9	6.5	0.2	33.6	1.70	12	3	●			ZH33...

Weitere HM Sorten können Sie in der Sortenübersicht im Kapitel "Technische Hinweise" und der Preisliste finden.

Bestellbeispiel:
für Sorte AL41F:
Z33.200.42.10/AL41F

More carbide grades you can find in the grades summary in the chapter "technical instructions" and in the price list.

order-example:
grade AL41F:
Z33.200.42.10/AL41F

MINIMILL

Nut-, Formzirkular- und
Trennfräsen

groove milling by
circular interpolation,
groove and slot milling

Typ Z635 / Z635.X

Nutfräsen allgemein

D min. 35 mm
t max. = 10

groove milling general use

D min. 35 mm
t max. = 10

Z635 geradverzahnt / spur-toothed

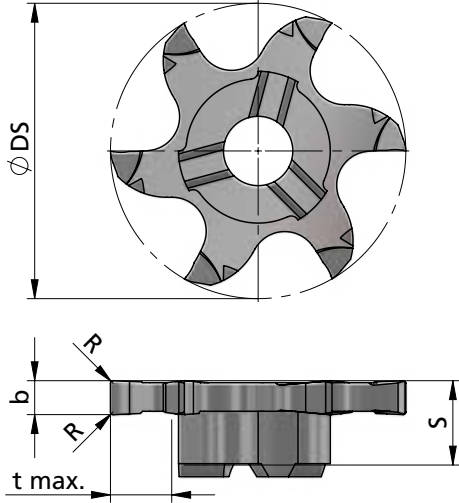

Z635.X kreuzverzahnt / staggered-toothed

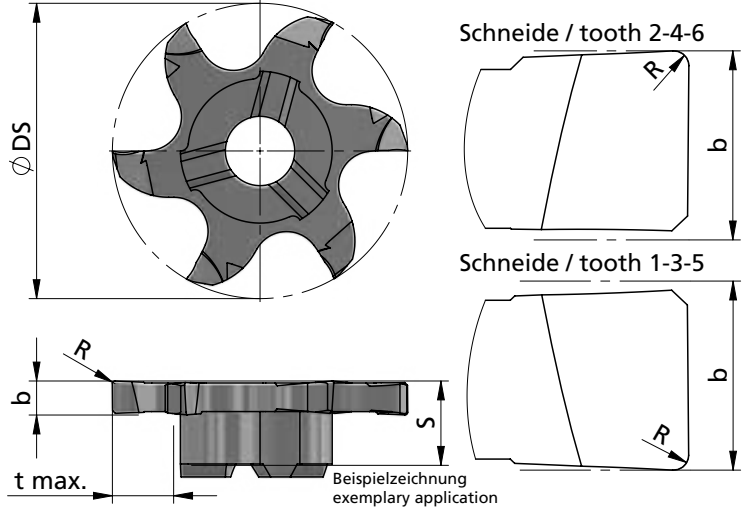

Abmessungen in mm

dimensions in mm

Bestellnummer part number	D min.	S	R	Ø DS	b +0.02	t max.	Zähnezahl number of teeth	K10F AL41F P18C	für Fräterschaft for milling shank
Z635.0150.01	35	6.25	0.1	34.7	1.5	10.0	6	●	ZH28...
Z635.0200.02	35	6.25	0.2	34.7	2.0	10.0	6	●	
Z635.X200.02	35	6.25	0.2	34.7	2.0	10.0	6	●	
Z635.0250.02	35	6.25	0.2	34.7	2.5	10.0	6	●	
Z635.X250.02	35	6.25	0.2	34.7	2.5	10.0	6	●	
Z635.0300.02	35	6.25	0.2	34.7	3.0	10.0	6	●	
Z635.X300.02	35	6.25	0.2	34.7	3.0	10.0	6	●	

Weitere HM Sorten können Sie in der Sortenübersicht im Kapitel "Technische Hinweise" und der Preisliste finden.

Bestellbeispiel:
für Sorte AL41F:
Z635.0150.01/AL41F

More carbide grades you can find in the grades summary in the chapter "technical instructions" and in the price list.

order-example:
grade AL41F:
Z635.0150.01/AL41F

MINIMILL

Nut-, Formzirkular- und Trennfräsen

groove milling by circular interpolation, groove and slot milling

Typ Z637 / Z637.X / Z640

Nutfräsen allgemein

groove milling general use

D min. 37 / 40 mm
t max. = 12 / 13.5

D min. 37 / 40 mm
t max. = 12 / 13.5



Z637/Z640 geradverzahnt / spur-toothed

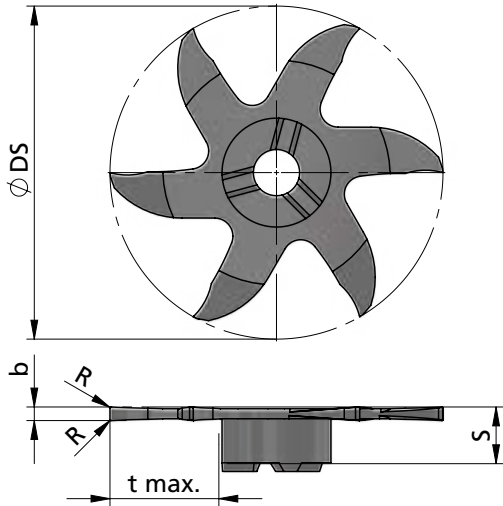

Z637.X kreuzverzahnt / staggered-toothed

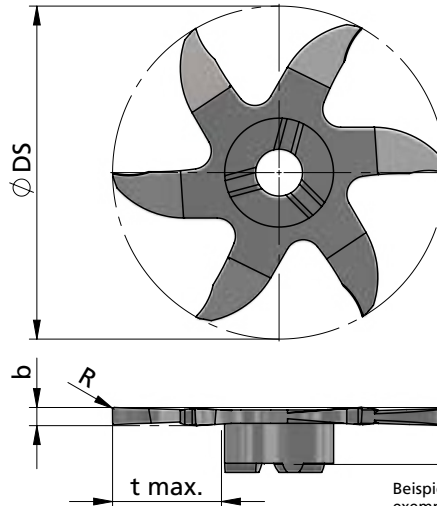

Schneide / tooth 2-4-6

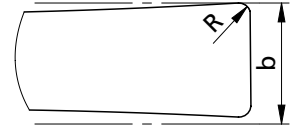

Schneide / tooth 1-3-5

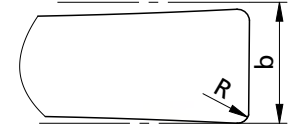

Beispielzeichnung
exemplary application

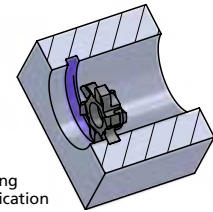

Abmessungen in mm

dimensions in mm

Bestellnummer part number	D min.	S	R	Ø DS	b +0.02	t max.	Zähnezahl number of teeth				für Fräterschaft for milling shank
								K10F	AL41F	P18C	
Z637.0100.01	37	6.25	0.1	36.7	1.0	12.0	6	●			ZH22...
Z640.0100.01	40	6.25	0.1	39.7	1.0	13.5	6		●		
Z637.0150.01	37	6.25	0.1	36.7	1.5	12.0	6		●		
Z637.X150.01	37	6.25	0.1	36.7	1.5	12.0	6		●		
Z640.0150.01	40	6.25	0.1	39.7	1.5	13.5	6		●		
Z637.X200.02	37	6.25	0.2	36.7	2.0	12.0	6		●		

Weitere HM Sorten können Sie in der Sortenübersicht im Kapitel "Technische Hinweise" und der Preisliste finden.

Bestellbeispiel:
für Sorte AL41F:
Z637.0100.01/AL41F

More carbide grades you can find in the grades summary in the chapter "technical instructions" and in the price list.

order-example:
grade AL41F:
Z637.0100.01/AL41F

MINIMILL

Nut-, Formzirkular- und
Trennfräsen

groove milling by
circular interpolation,
groove and slot milling

Typ Z637 / Z640

Nut- und Trennfräsen

groove and slot milling

D min. 37 / 40 mm
t max. = 12 / 13.5
b = 0.4 - 0.8 mm

D min. 37 / 40 mm
t max. = 12 / 13.5
b = 0.4 - 0.8 mm

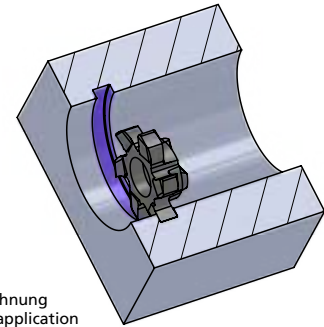
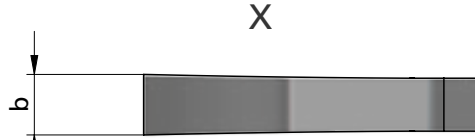
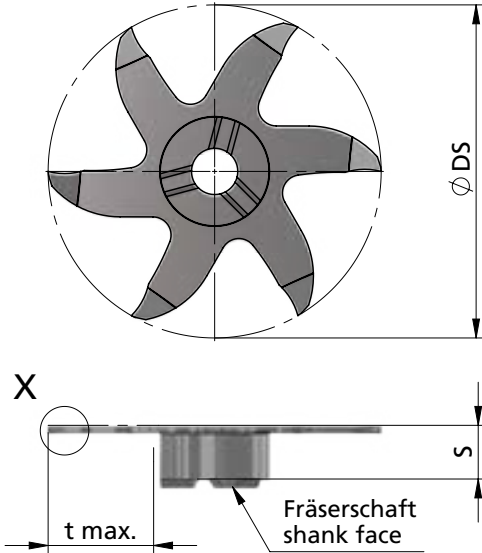

Beispielzeichnung
exemplary application

Abmessungen in mm

dimensions in mm

Bestellnummer part number	D min.	s	$\varnothing DS$	b +0.05	t max.	Zähnezahl number of teeth				für Fräferschaft for milling shank
							K10F	AL41F	P18C	
Z640.0040.00	40	6.0	39.7	0.4	13.5	6		●		
Z637.0050.00	37	6.0	36.7	0.5	12.0	6		●		
Z640.0050.00	40	6.0	39.7	0.5	13.5	6		●		
Z637.0060.00	37	5.7	36.7	0.6	12.0	6		●		ZH22...
Z640.0060.00	40	5.7	39.7	0.6	13.5	6		●		
Z637.0080.00	37	5.9	36.7	0.8	12.0	6		●		
Z640.0080.00	40	5.9	39.7	0.8	13.5	6		●		

Weitere HM Sorten können Sie in der Sorten-
übersicht im Kapitel "Technische Hinweise" und
der Preisliste finden.

Bestellbeispiel:
für Sorte AL41F:
Z640.0040.00/AL41F

More carbide grades you can find in the grades
summary in the chapter "technical instructions"
and in the price list.

order-example:
grade AL41F:
Z640.0040.00/AL41F

MINIMILL

Nut-, Formzirkular- und Trennfräsen

groove milling by circular interpolation, groove and slot milling

Typ Z635 / Z637 / Z640

Trennfräsen

slot milling

Schneidkreis-Ø DS ab 34.7 mm

t max. = 10 / 12 / 13.5

b = 1.0 / 1.5 mm

cutting edge-Ø DS starting at 34.7 mm

t max. = 10 / 12 / 13.5

b = 1.0 / 1.5 mm

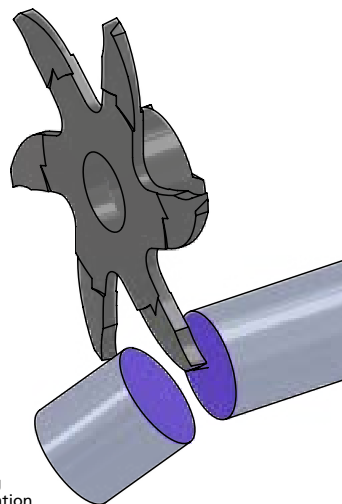
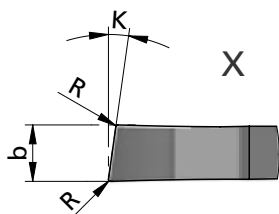
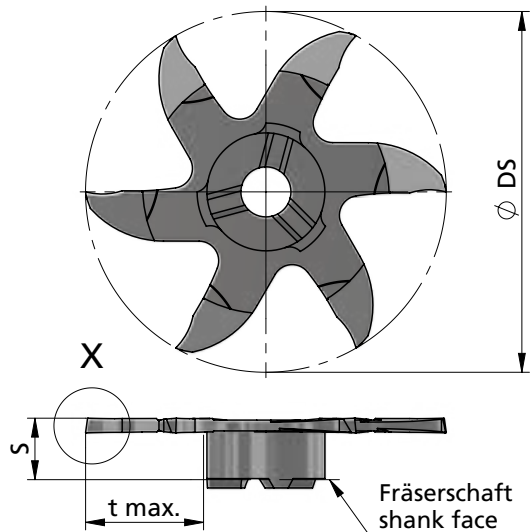

Beispielzeichnung
exemplary application



Abmessungen in mm

dimensions in mm

Bestellnummer part number	Ø DS	S	K	b+0.02	R	t max.	Zähnezahl number of teeth	K10F AL41F P18C	für Fräterschaft for milling shank
Z635.L810.005	34.7	6.25	8°	1.0	0.05	10	6	●	ZH28...
Z635.L815.005	34.7	6.25	8°	1.5	0.05	10	6	●	
Z637.L810.005	36.7	6.25	8°	1.0	0.05	12	6	●	ZH22...
Z637.L815.005	36.7	6.25	8°	1.5	0.05	12	6	●	
Z640.L810.005	39.7	6.25	8°	1.0	0.05	13.5	6	●	
Z640.L815.005	39.7	6.25	8°	1.5	0.05	13.5	6	●	

Weitere HM Sorten können Sie in der Sortenübersicht im Kapitel "Technische Hinweise" und der Preisliste finden.

Bestellbeispiel:
für Sorte AL41F:
Z635.L810.005/AL41F

More carbide grades you can find in the grades summary in the chapter "technical instructions" and in the price list.

order-example:
grade AL41F:
Z635.L810.005/AL41F

MINIMILL

Nut-, Formzirkular- und
Trennfräsen

groove milling by
circular interpolation,
groove and slot milling

Typ Z12

Vollradius

full radius

D min. 12 mm
t max. = 2.5

D min. 12 mm
t max. = 2.5

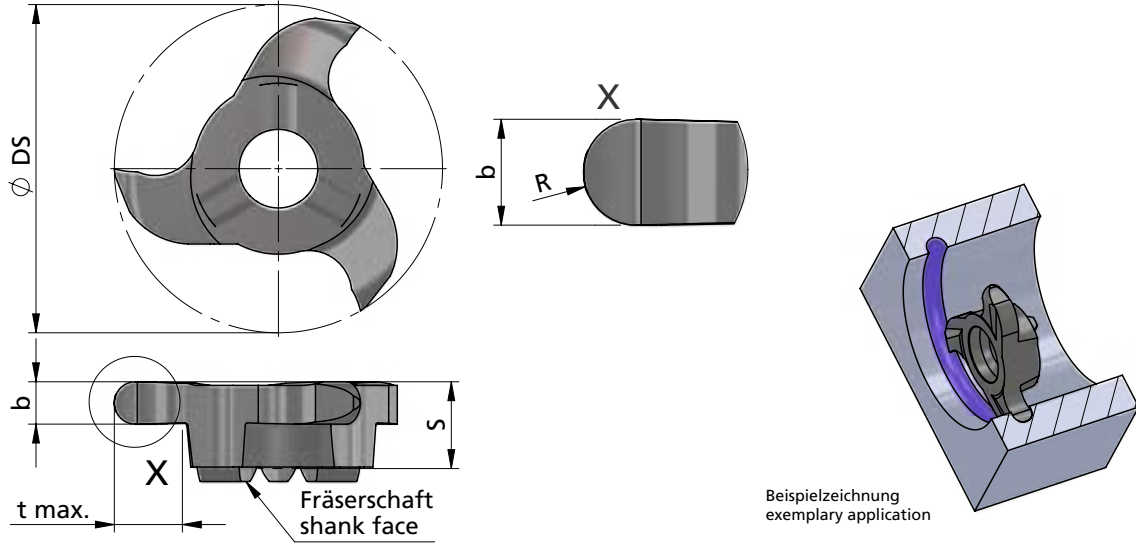

Abmessungen in mm

dimensions in mm

Bestellnummer part number	D min.	S	R	Ø DS	b +0.03	t max.	Zähnezahl number of teeth				für Fräterschaft for milling shank
								K10F	AL41F	P18C	
Z12.0005.10	12	3.5	0.5	11.7	1.0	2.5	3	●	●		ZH10...
Z12.0007.15	12	3.5	0.75	11.7	1.5	2.5	3	●	●		
Z12.0010.20	12	3.5	1.0	11.7	2.0	2.5	3	●	●		
Z12.0011.22	12	3.5	1.1	11.7	2.2	2.5	3	●	●		
Z12.0015.30	12	3.5	1.5	11.7	3.0	2.5	3	●	●		

Weitere HM Sorten können Sie in der Sorten-
übersicht im Kapitel "Technische Hinweise" und
der Preisliste finden.

Bestellbeispiel:
für Sorte AL41F:
Z12.0005.10/AL41F

More carbide grades you can find in the grades
summary in the chapter "technical instructions"
and in the price list.

order-example:
grade AL41F:
Z12.0005.10/AL41F

MINIMILL

Nut-, Formzirkular- und Trennfräsen

groove milling by circular interpolation, groove and slot milling

Typ Z16

Vollradius

D min. 16 mm
t max. = 3.5

full radius

D min. 16 mm
t max. = 3.5

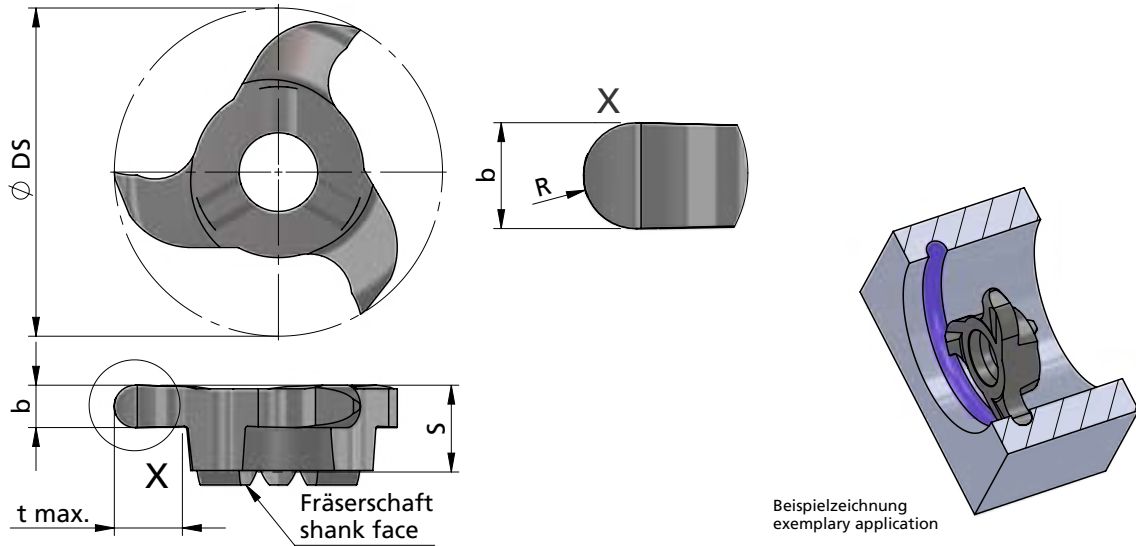

Abmessungen in mm

dimensions in mm



Bestellnummer part number	D min.	S	R	$\varnothing DS$	b +0.03	t max.	Zähnezahl number of teeth	Material			für Fräseschaft for milling shank
								K10F	AL41F	P18C	
Z16.0011.22	16	4.5	1.1	15.7	2.2	3.5	3	●			ZH14...

Weitere HM Sorten können Sie in der Sortenübersicht im Kapitel "Technische Hinweise" und der Preisliste finden.

Bestellbeispiel:
für Sorte AL41F:
Z16.0011.22/AL41F

More carbide grades you can find in the grades summary in the chapter "technical instructions" and in the price list.

order-example:
grade AL41F:
Z16.0011.22/AL41F

MINIMILL

Nut-, Formzirkular- und
Trennfräsen

groove milling by
circular interpolation,
groove and slot milling

Typ Z18

Vollradius

D min. 18 mm
t max. = 3.5

full radius

D min. 18 mm
t max. = 3.5

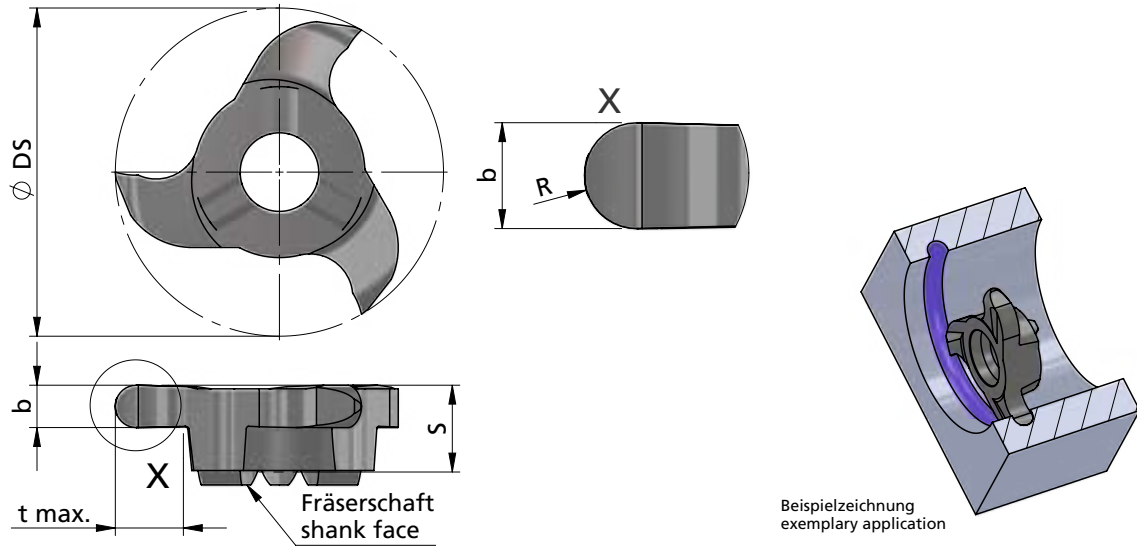

Abmessungen in mm

dimensions in mm

Bestellnummer part number	Abmessungen in mm / dimensions in mm								Material			für Fräterschaft for milling shank
	D min.	S	R	$\varnothing DS$	b +0.03	b (inch)	t max.	Zähnezahl number of teeth	K10F	AL41F	P18C	
Z18.0010.20	18	5.75	1.0	17.7	2.00		3.5	3	●			ZH18...
Z18.0011.22	18	5.75	1.1	17.7	2.20		3.5	3		●		
Z18.U011.23	18	5.75	1.19	17.7	2.38	0.094"	3.5	3	●	●		
Z18.0015.30	18	5.75	1.5	17.7	3.00		3.5	3		●		

Weitere HM Sorten können Sie in der Sorten-
übersicht im Kapitel "Technische Hinweise" und
der Preisliste finden.

More carbide grades you can find in the grades
summary in the chapter "technical instructions"
and in the price list.

MINIMILL

Nut-, Formzirkular- und Trennfräsen

groove milling by circular interpolation, groove and slot milling

Typ Z22

Vollradius

D min. 22 mm
t max. = 4.5

full radius

D min. 22 mm
t max. = 4.5

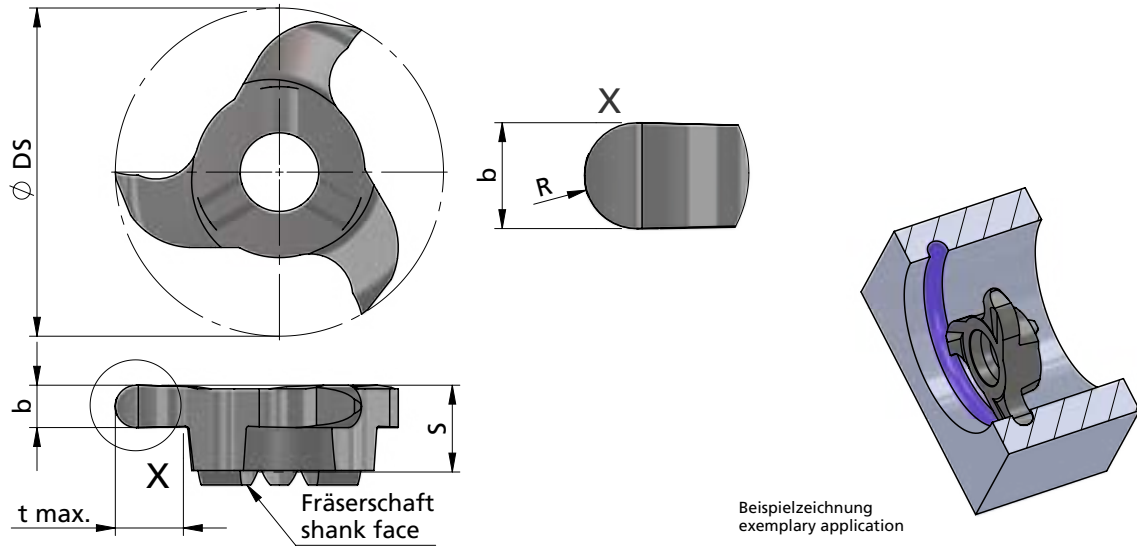

Abmessungen in mm

dimensions in mm



Bestellnummer part number	dimensions in mm								Zähnezahl number of teeth	Material			für Fräterschaft for milling shank
	D min.	S	R	$\varnothing DS$	b +0.03	b (inch)	t max.	K10F		AL41F	P18C		
Z22.0005.10	22	5.75	0.5	21.7	1.00		4.5	3		●		ZH22...	
Z22.0008.16	22	5.75	0.8	21.7	1.60		4.5	3		●			
Z22.0010.20	22	5.75	1.0	21.7	2.00		4.5	3	●	●			
Z22.0012.24	22	5.75	1.2	21.7	2.40		4.5	3		●			
Z22.0014.28	22	5.75	1.4	21.7	2.80		4.5	3		●			
Z22.0015.30	22	5.75	1.5	21.7	3.00		4.5	3		●			
Z22.U015.31	22	5.75	1.57	21.7	3.17	0.125"	4.5	3		●			
Z22.0020.40	22	5.75	2.0	21.7	4.00		4.5	3		●			
Z22.0022.44	22	5.75	2.2	21.7	4.40		4.5	3		●			
Z22.0025.50	22	5.75	2.5	21.7	5.00		4.5	3		●			

Weitere HM Sorten können Sie in der Sortenübersicht im Kapitel "Technische Hinweise" und der Preisliste finden.

Bestellbeispiel:
für Sorte AL41F:
Z22.0025.50/AL41F

More carbide grades you can find in the grades summary in the chapter "technical instructions" and in the price list.

order-example:
grade AL41F:
Z22.0025.50/AL41F

MINIMILL

Nut-, Formzirkular- und
Trennfräsen

groove milling by
circular interpolation,
groove and slot milling

Impressionen

impressions

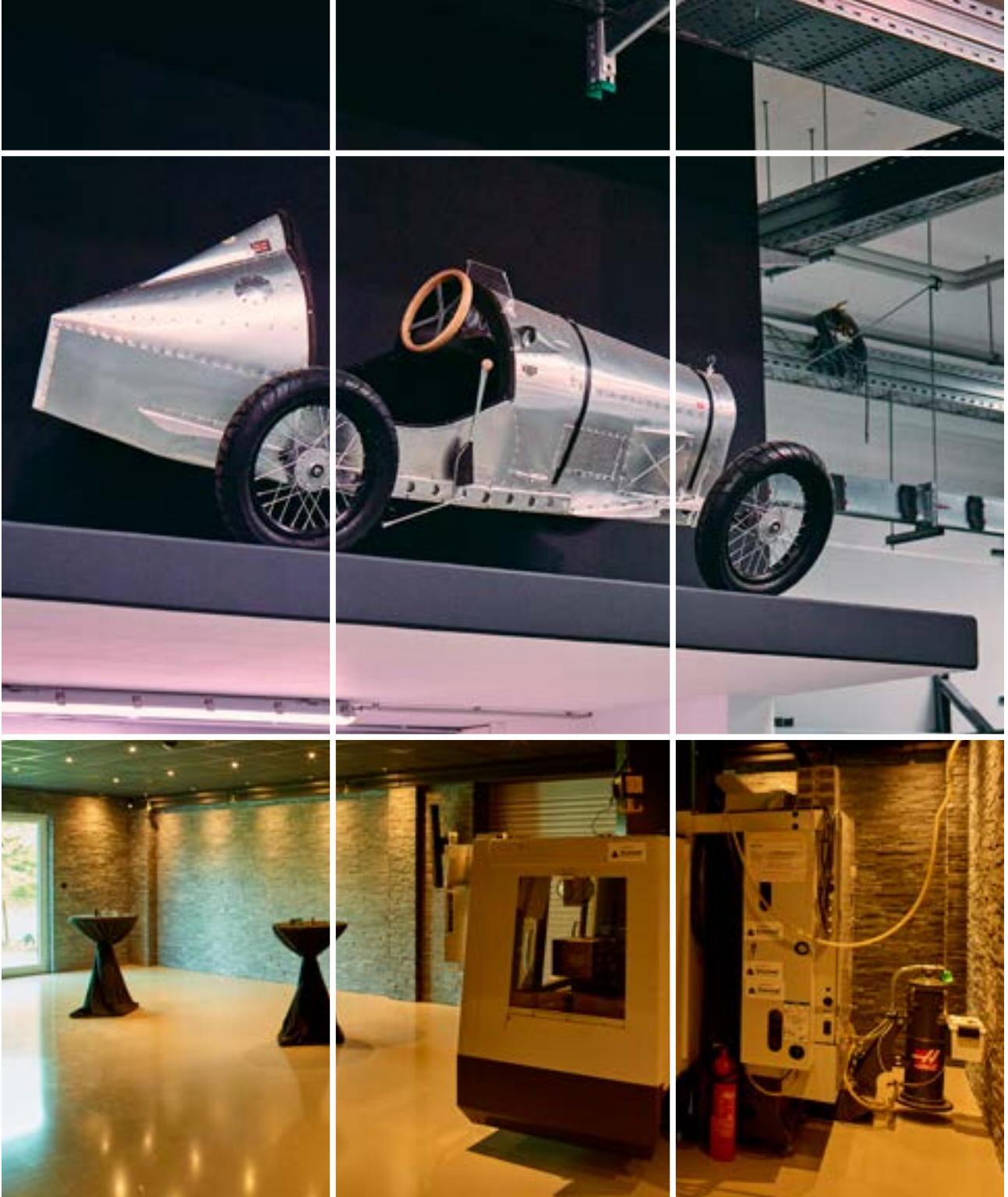

MINIMILL

Nut-, Formzirkular- und Trennfräsen

groove milling by circular interpolation, groove and slot milling

Typ Z8

metrisches ISO-Gewinde, Teilprofil, innen

metric ISO-thread, partial profile, internal

Gewinde-Ø ≥ 10 x 0.4 mm

thread-Ø ≥ 10 x 0.4 mm

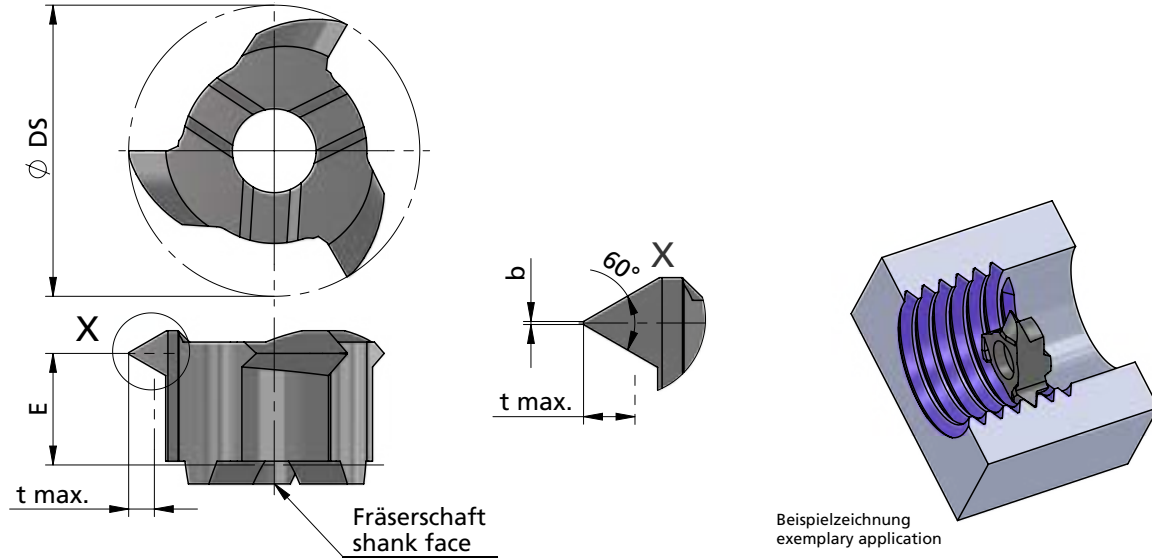

Abmessungen in mm

dimensions in mm



Bestellnummer part number	von Steigung P empfohlen as of pitch P recommended	bis Steigung P möglich up to pitch P possible	min. Gewinde-Ø min. thread-Ø		Ø DS	b	t max.	Zähnezahl number of teeth	K10F AL41F P18C	für Fräterschaft for milling shank
			E							
Z8.TP040	0.4	0.5	10	2.95	6.7	0.03	0.35	3	●	
Z8.TP050	0.5	1.0	10	2.95	7.7	0.04	0.68	3	●	ZH8,...

Weitere HM Sorten können Sie in der Sortenübersicht im Kapitel "Technische Hinweise" und der Preisliste finden.

Bestellbeispiel:
für Sorte AL41F:
Z8.TP040/AL41F

More carbide grades you can find in the grades summary in the chapter "technical instructions" and in the price list.

order-example:
grade AL41F:
Z8.TP040/AL41F

MINIMILL

Nut-, Formzirkular- und Trennfräsen

groove milling by circular interpolation, groove and slot milling

Typ Z8

metrisches ISO-Gewinde, Vollprofil, innen

metric ISO-thread, full profile, internal

Gewinde- $\emptyset \geq 8 \times 0.4 \text{ mm}$

thread- $\emptyset \geq 8 \times 0.4 \text{ mm}$

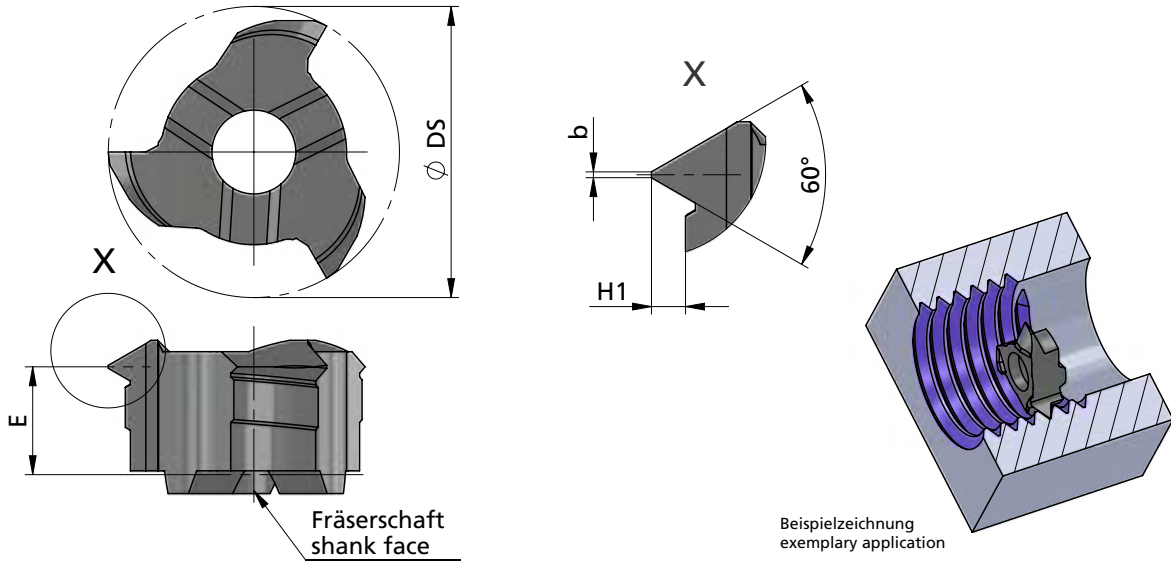

Beispielzeichnung
exemplary application

Abmessungen in mm

dimensions in mm

Bestellnummer part number	Steigung P pitch P	min. Gewinde- \emptyset min. thread- \emptyset	E	\emptyset DS	b	H1	Zähnezahl number of teeth	K10F AL41F P18C	für Fräaserschaft for milling shank
Z8.VP040	0.40	8	3.00	6.7	0.05	0.22	3	●	ZH8,...
Z8.VP045	0.45	8	3.00	6.7	0.06	0.24	3	●	
Z8.VP050	0.50	8	2.95	6.7	0.06	0.27	3	●	
Z8.VP060	0.60	8	2.90	6.7	0.08	0.32	3	●	
Z8.VP070	0.70	8	2.85	6.7	0.09	0.38	3	●	
Z8.VP075	0.75	10	2.85	7.7	0.09	0.41	3	●	
Z8.VP080	0.80	10	2.85	7.7	0.09	0.43	3	●	
Z8.VP100	1.00	10	2.75	7.7	0.13	0.54	3	●	

Weitere HM Sorten können Sie in der Sortenübersicht im Kapitel "Technische Hinweise" und der Preisliste finden.

Bestellbeispiel:
für Sorte AL41F:
Z8.VP040/AL41F

More carbide grades you can find in the grades summary in the chapter "technical instructions" and in the price list.

order-example:
grade AL41F:
Z8.VP040/AL41F

MINIMILL

Nut-, Formzirkular- und Trennfräsen

groove milling by circular interpolation, groove and slot milling

Typ Z610

metrisches ISO-Gewinde, Teilprofil, innen

metric ISO-thread, partial profile, internal

Gewinde-Ø ≥ 12 x 1.0 mm

thread-Ø ≥ 12 x 1.0 mm

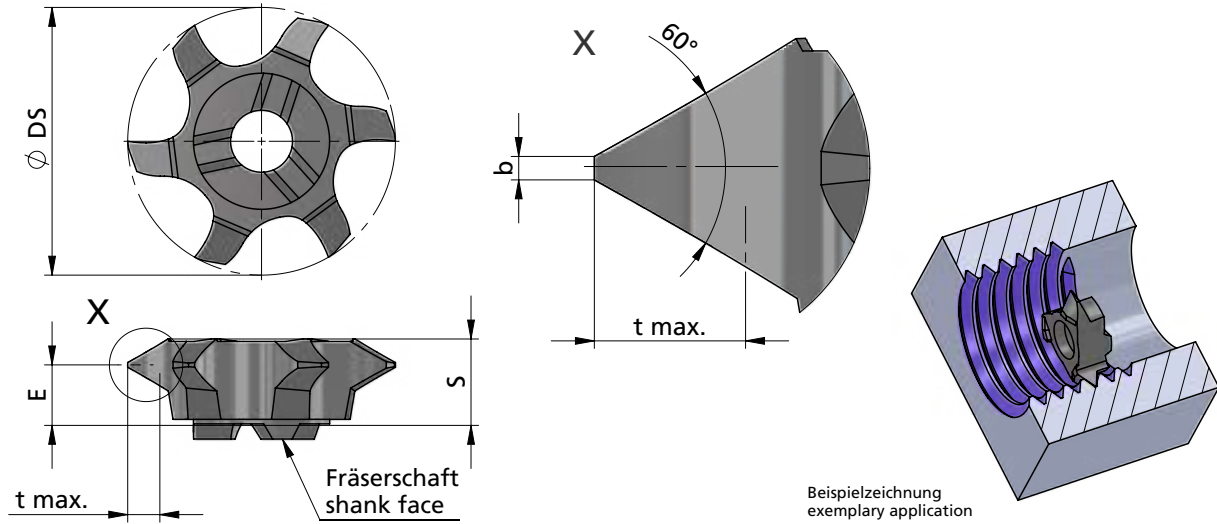

Abmessungen in mm

dimensions in mm

Bestellnummer part number	von Steigung P empfohlen as of pitch P recommended	bis Steigung P möglich up to pitch P possible	min. Gewinde-Ø min. thread-Ø							Zähnezahl number of teeth	K10F AL41F P18C	für Fräsertschaft for milling shank
			S	E	Ø DS	b	t max.					
Z610.0510.01	1.0	1.75	12	3.2	2.4	9.8	0.13	1.08	6	●	ZH10...	
Z610.0720.01	1.0	2.00	14	3.2	2.2	10.1	0.13	1.25	6	●		
Z610.0815.01	1.5	2.75	16	3.2	2.0	11.0	0.19	1.67	6	●		
Z610.2530.01	2.0	3.00	16	3.2	1.9	11.1	0.25	1.78	6	●		

Weitere HM Sorten können Sie in der Sortenübersicht im Kapitel "Technische Hinweise" und der Preisliste finden.

Bestellbeispiel:
für Sorte AL41F:
Z610.0510.01/AL41F

More carbide grades you can find in the grades summary in the chapter "technical instructions" and in the price list.

order-example:
grade AL41F:
Z610.0510.01/AL41F

MINIMILL

Nut-, Formzirkular- und Trennfräsen

groove milling by circular interpolation, groove and slot milling

Typ Z10

metrisches ISO-Gewinde, Vollprofil, innen

metric ISO-thread, full profile, internal

Gewinde-Ø ≥ 12 x 0.75 mm

thread-Ø ≥ 12 x 0.75 mm

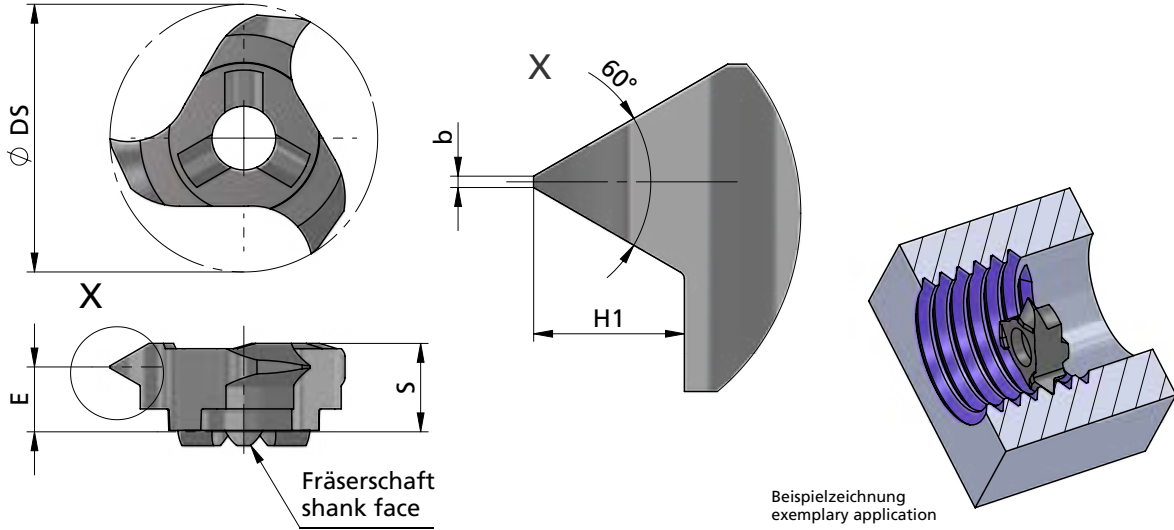

Abmessungen in mm

dimensions in mm

Bestellnummer part number	Steigung P pitch P	min. Gewinde-Ø min. thread-Ø	S	E	Ø DS	b	H1	Zähnezahl number of teeth	K10F AL41F P18C	für Fräterschaft for milling shank
Z10.0407.02	0.75	12	3.6	3.1	9.7	0.09	0.41	3	●	ZH10...
Z10.0510.02	1.00	12	3.6	3.0	9.7	0.13	0.54	3	●	
Z10.0815.02	1.50	14	3.6	2.8	9.7	0.19	0.81	3	●	
Z10.0917.02	1.75	14	3.6	2.7	9.7	0.20	0.95	3	●	
Z10.1020.02	2.00	14	3.6	2.6	9.7	0.25	1.08	3	●	
Z10.1325.02	2.50	16	3.6	2.4	9.7	0.31	1.35	3	●	

Weitere HM Sorten können Sie in der Sortenübersicht im Kapitel "Technische Hinweise" und der Preisliste finden.

Bestellbeispiel:
für Sorte AL41F:
Z10.0407.02/AL41F

More carbide grades you can find in the grades summary in the chapter "technical instructions" and in the price list.

order-example:
grade AL41F:
Z10.0407.02/AL41F

MINIMILL

Nut-, Formzirkular- und Trennfräsen

groove milling by circular interpolation, groove and slot milling

Typ Z12

metrisches ISO-Gewinde, Teilprofil, innen

metric ISO-thread, partial profile, internal

Gewinde-Ø ≥ 14 x 1.0 mm

thread-Ø ≥ 14 x 1.0 mm

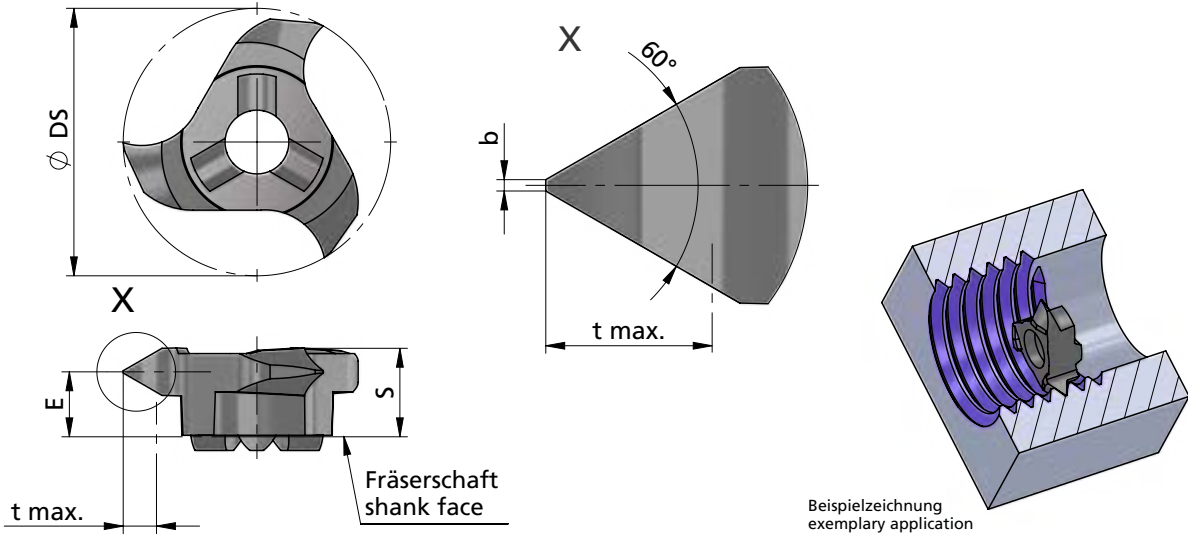

Beispielzeichnung
exemplary application

Abmessungen in mm

dimensions in mm

Bestellnummer part number	von Steigung P empfohlen as of pitch P recommended	bis Steigung P möglich up to pitch P possible	min. Gewinde-Ø min. thread-Ø			Zähnezahl number of teeth	K10F	AL41F	P18C	für Fräterschaft for milling shank
			S	E	Ø DS					
Z12.0510.01	1.0	1.75	14	3.6	2.8	11.7	0.13	1.08	3	ZH10...
Z12.0720.01	1.0	2.00	14	3.6	2.8	11.7	0.13	1.25	3	
Z12.0815.01	1.5	2.75	16	3.6	2.4	11.7	0.19	1.67	3	
Z12.2530.01	2.0	3.00	16	3.6	2.2	11.7	0.25	1.78	3	

Weitere HM Sorten können Sie in der Sortenübersicht im Kapitel "Technische Hinweise" und der Preisliste finden.

Bestellbeispiel:
für Sorte AL41F:
Z12.0510.01/AL41F

More carbide grades you can find in the grades summary in the chapter "technical instructions" and in the price list.

order-example:
grade AL41F:
Z12.0510.01/AL41F

MINIMILL

Nut-, Formzirkular- und Trennfräsen

groove milling by circular interpolation, groove and slot milling

Typ Z614

metrisches ISO-Gewinde, Teilprofil, innen

metric ISO-thread, partial profile, internal

Gewinde-Ø ≥ 16 x 1.0 mm

thread-Ø ≥ 16 x 1.0 mm

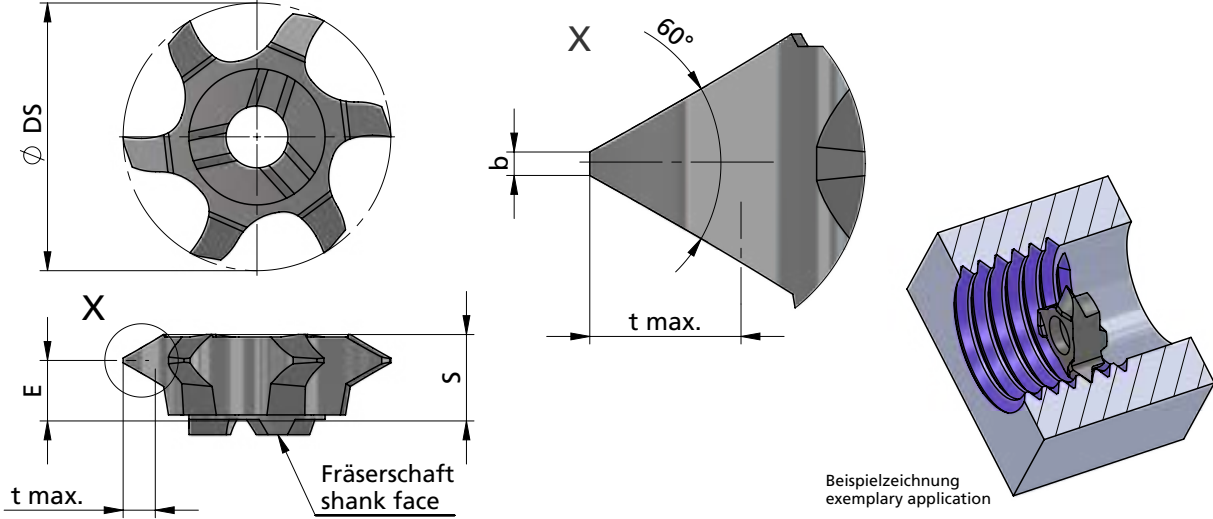

Abmessungen in mm

dimensions in mm

Bestellnummer part number	von Steigung P empfohlen as of pitch P recommended	bis Steigung P möglich up to pitch P possible	min. Gewinde-Ø min. thread-Ø			Zähnezahl number of teeth	t max.	für Fräterschaft for milling shank					
			S	E	Ø DS			b	K10F	AL41F	P18C		
Z614.0510.01	1.0	1.75	16	4.2	3.4	12.0	0.13	1.08	6	●	●	●	ZH14...
Z614.0720.01	1.0	2.00	16	4.2	3.6	12.3	0.13	1.25	6	●	●	●	
Z614.0815.01	1.5	2.75	18	4.2	3.0	13.2	0.19	1.67	6	●	●	●	
Z614.2530.01	2.0	3.00	18	4.2	2.8	13.3	0.25	1.78	6	●	●	●	

Weitere HM Sorten können Sie in der Sortenübersicht im Kapitel "Technische Hinweise" und der Preisliste finden.

Bestellbeispiel:
für Sorte AL41F:
Z614.0510.01/AL41F

More carbide grades you can find in the grades summary in the chapter "technical instructions" and in the price list.

order-example:
grade AL41F:
Z614.0510.01/AL41F

MINIMILL

Nut-, Formzirkular- und Trennfräsen

groove milling by circular interpolation, groove and slot milling

Typ Z14

metrisches ISO-Gewinde, Vollprofil, innen

metric ISO-thread, full profile, internal

Gewinde-Ø ≥ 16 x 1.0 mm

thread-Ø ≥ 16 x 1.0 mm

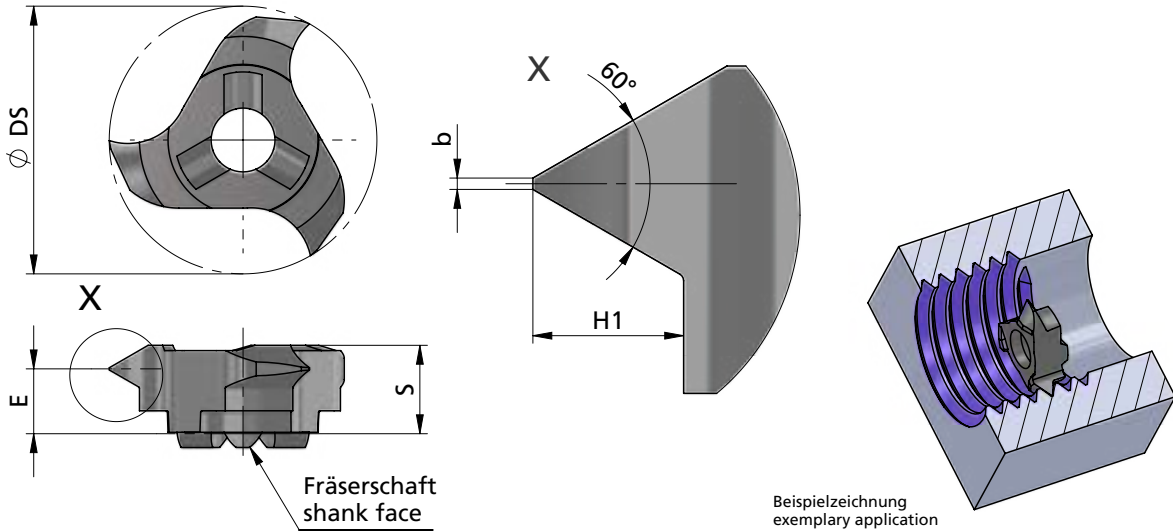

Abmessungen in mm

dimensions in mm



Bestellnummer part number	Steigung P pitch P	min. Gewinde-Ø min. thread-Ø	S	E	Ø DS	b	H1	Zähnezahl number of teeth	K10F AL41F P18C	für Frälerschaft for milling shank
Z14.0510.02	1.00	16	4.5	3.6	13.7	0.13	0.54	3	●	ZH14...
Z14.0815.02	1.50	18	4.5	3.5	13.7	0.19	0.81	3	●	
Z14.0917.02	1.75	18	4.5	3.4	13.7	0.20	0.95	3	●	
Z14.1020.02	2.00	18	4.5	3.3	13.7	0.25	1.08	3	●	
Z14.1325.02	2.50	20	4.5	3.1	13.7	0.31	1.35	3	●	
Z14.1630.02	3.00	22	4.5	2.9	13.7	0.37	1.62	3	●	

Weitere HM Sorten können Sie in der Sortenübersicht im Kapitel "Technische Hinweise" und der Preisliste finden.

Bestellbeispiel:
für Sorte AL41F:
Z14.0510.02/AL41F

More carbide grades you can find in the grades summary in the chapter "technical instructions" and in the price list.

order-example:
grade AL41F:
Z14.0510.02/AL41F

MINIMILL

Nut-, Formzirkular- und Trennfräsen

groove milling by circular interpolation, groove and slot milling

Typ Z16

metrisches ISO-Gewinde, Teilprofil, innen

metric ISO-thread, partial profile, internal

Gewinde-Ø ≥ 18 x 1.0 mm

thread-Ø ≥ 18 x 1.0 mm

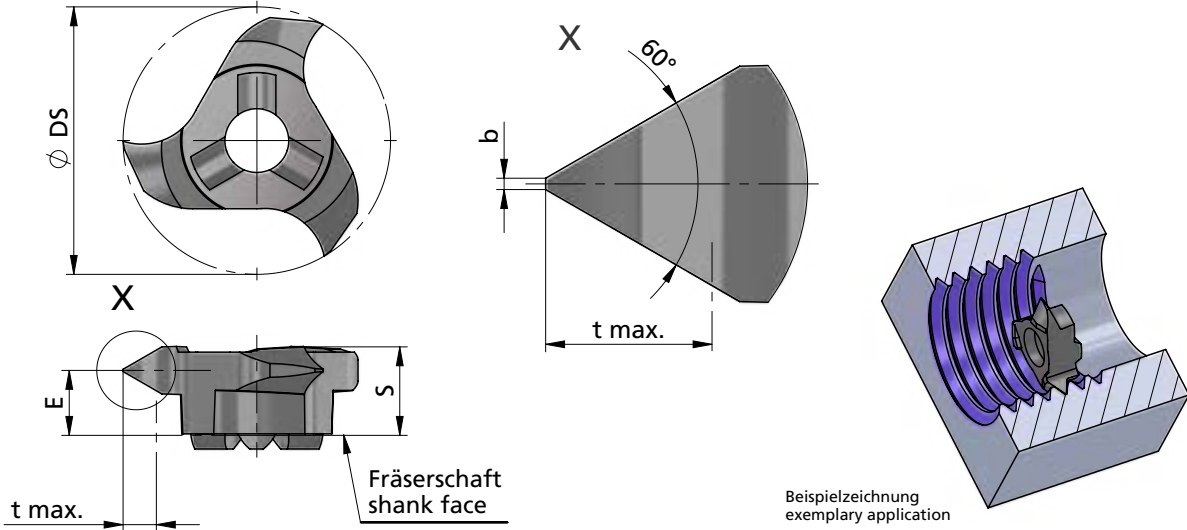

Abmessungen in mm

dimensions in mm

Bestellnummer part number	von Steigung P empfohlen as of pitch P recommended	bis Steigung P möglich up to pitch P possible	min. Gewinde-Ø min. thread-Ø				Zähnezahl number of teeth	für Fräterschaft for milling shank				
			S	E	Ø DS	b		t max.	K10F	AL41F	P18C	
Z16.0510.01	1.0	1.75	18	4.6	3.8	15.7	0.12	1.08	3	●	●	●
Z16.0720.01	1.0	2.00	18	4.6	3.5	15.7	0.12	1.25	3	●	●	●
Z16.0815.01	1.5	2.75	20	4.6	3.5	15.7	0.19	1.67	3	●	●	●
Z16.2530.01	2.5	3.00	22	4.6	3.4	15.7	0.31	1.78	3	●	●	●

Weitere HM Sorten können Sie in der Sortenübersicht im Kapitel "Technische Hinweise" und der Preisliste finden.

Bestellbeispiel:
für Sorte AL41F:
Z16.0510.01/AL41F

More carbide grades you can find in the grades summary in the chapter "technical instructions" and in the price list.

order-example:
grade AL41F:
Z16.0510.01/AL41F

MINIMILL

Nut-, Formzirkular- und Trennfräsen

groove milling by circular interpolation, groove and slot milling

Typ Z18

metrisches ISO-Gewinde, Teilprofil, innen

metric ISO-thread, partial profile, internal

Gewinde-Ø ≥ 22 x 1.0 mm

thread-Ø ≥ 22 x 1.0 mm

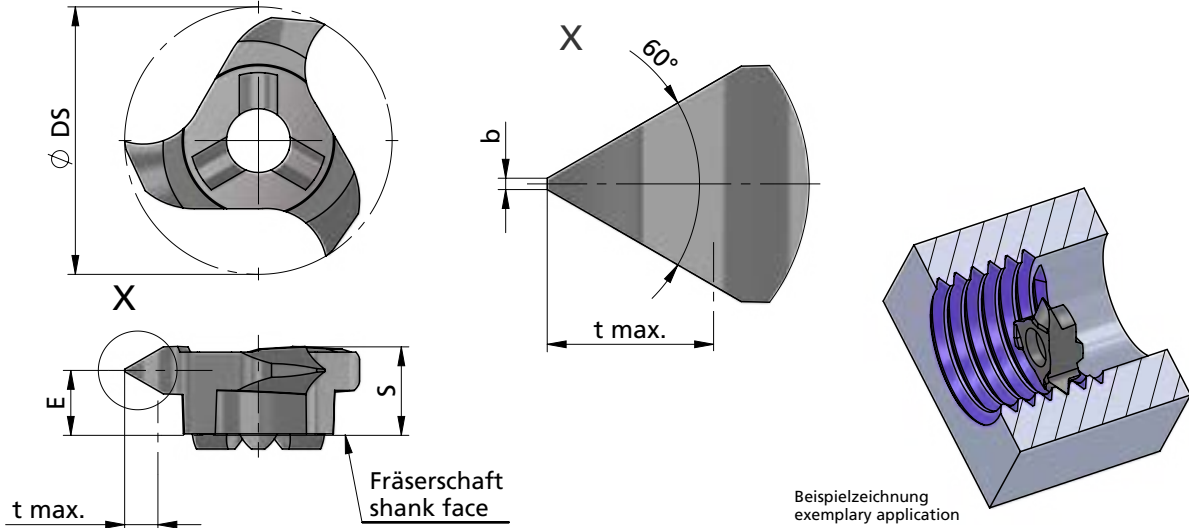

Abmessungen in mm

dimensions in mm



Bestellnummer part number	von Steigung P empfohlen as of pitch P recommended	bis Steigung P möglich up to pitch P possible	min. Gewinde-Ø min. thread-Ø	Abmessungen in mm / dimensions in mm						Zähnezahl number of teeth	K10F AL41F P18C	für Fräsertschaft for milling shank
				S	E	Ø DS	b	t max.				
Z18.0510.01	1.0	1.75	22	5.85	5.0	17.7	0.12	1.03	3	●	ZH18...	
Z18.0720.01	1.0	2.00	22	5.85	4.7	17.7	0.12	1.19	3	●		
Z18.0815.01	1.5	2.75	22	5.85	4.6	17.7	0.19	1.62	3	●		
Z18.1020.01	2.0	3.75	24	5.85	4.2	17.7	0.25	2.22	3	●		
Z18.1325.01	2.0	3.00	24	5.85	4.4	17.7	0.25	1.73	3	●		
Z18.1630.01	2.5	5.00	24	5.85	3.8	17.7	0.31	2.98	3	●		
Z18.1835.01	3.0	5.50	24	5.85	3.6	17.7	0.38	3.25	3	●		
Z18.2535.01	2.0	3.50	24	5.85	4.2	17.7	0.25	2.06	3	●		

Weitere HM Sorten können Sie in der Sortenübersicht im Kapitel "Technische Hinweise" und der Preisliste finden.

Bestellbeispiel:
für Sorte AL41F:
Z18.0510.01/AL41F

More carbide grades you can find in the grades summary in the chapter "technical instructions" and in the price list.

order-example:
grade AL41F:
Z18.0510.01/AL41F

MINIMILL

Nut-, Formzirkular- und Trennfräsen

groove milling by circular interpolation, groove and slot milling

Typ Z618

metrisches ISO-Gewinde, Teilprofil, innen

metric ISO-thread, partial profile, internal

Gewinde-Ø ≥ 22 x 1.0 mm

thread-Ø ≥ 22 x 1.0 mm

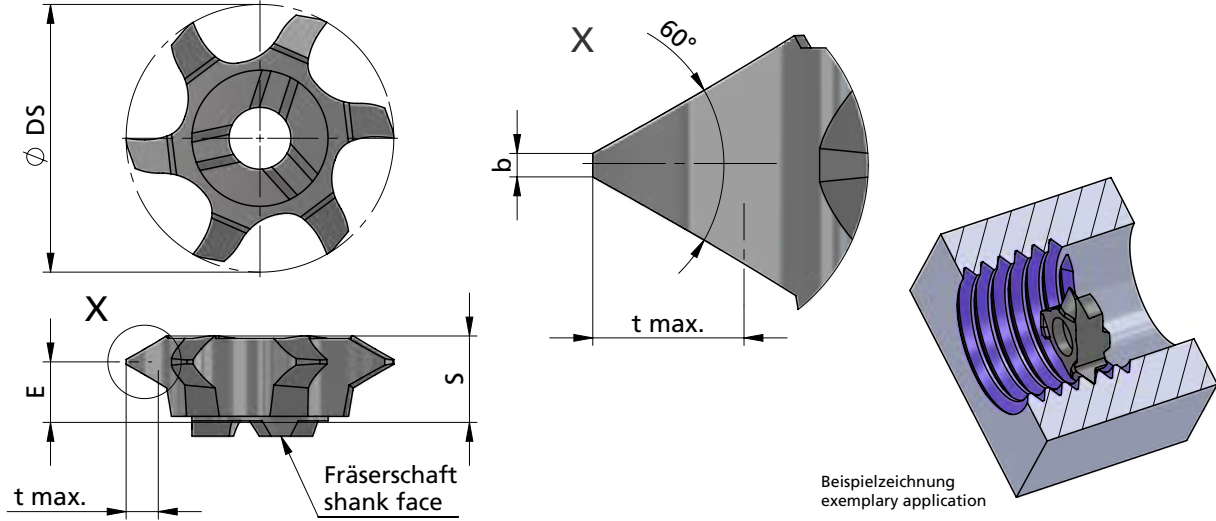

Beispielzeichnung
exemplary application

Abmessungen in mm

dimensions in mm

Bestellnummer part number	von Steigung P empfohlen as of pitch P recommended	bis Steigung P möglich up to pitch P possible	min. Gewinde-Ø min. thread-Ø	dimensions in mm					Zähnezahl number of teeth	K10F AL41F P18C	für Fräaserschaft for milling shank
				S	E	Ø DS	b	t max.			
Z618.0720.01	1.0	2.0	22	5.85	4.6	17.7	0.12	1.19	6	●	ZH18...
Z618.2545.01	2.0	3.5	24	5.85	4.0	17.7	0.25	2.57	6	●	

Weitere HM Sorten können Sie in der Sortenübersicht im Kapitel "Technische Hinweise" und der Preisliste finden.

More carbide grades you can find in the grades summary in the chapter "technical instructions" and in the price list.

MINIMILL

Nut-, Formzirkular- und Trennfräsen

groove milling by circular interpolation, groove and slot milling

Typ Z18

metrisches ISO-Gewinde, Vollprofil, innen

metric ISO-thread, full profile, internal

Gewinde-Ø ≥ 22 x 1.5 mm

thread-Ø ≥ 22 x 1.5 mm

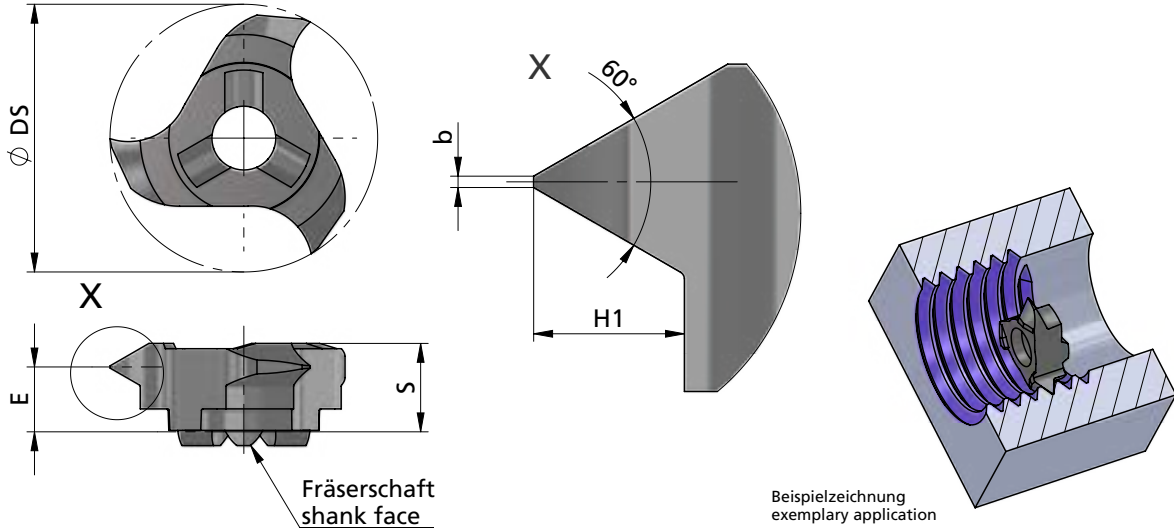

Fräseschaft
shank face

Beispielzeichnung
exemplary application

Abmessungen in mm

dimensions in mm



Bestellnummer part number	Steigung P pitch P	min. Gewinde-Ø min. thread-Ø	S	E	Ø DS	b	H1	Zähnezahl number of teeth	K10F AL41F P18C	für Fräseschaft for milling shank
Z18.0815.02	1.50	22	5.85	4.8	17.7	0.18	0.81	3	●	ZH18...
Z18.0917.02	1.75	22	5.85	4.7	17.7	0.20	0.95	3	●	
Z18.1020.02	2.00	22	5.85	4.6	17.7	0.25	1.08	3	●	
Z18.1325.02	2.50	24	5.85	4.4	17.7	0.31	1.35	3	●	
Z18.1630.02	3.00	27	5.85	4.3	17.7	0.37	1.62	3	●	
Z18.1835.02	3.50	27	5.85	4.0	17.7	0.43	1.895	3	●	

Weitere HM Sorten können Sie in der Sortenübersicht im Kapitel "Technische Hinweise" und der Preisliste finden.

Bestellbeispiel:
für Sorte AL41F:
Z18.0815.02/AL41F

More carbide grades you can find in the grades summary in the chapter "technical instructions" and in the price list.

order-example:
grade AL41F:
Z18.0815.02/AL41F

MINIMILL

Nut-, Formzirkular- und Trennfräsen

groove milling by circular interpolation, groove and slot milling

Typ Z618

metrisches ISO-Gewinde, Vollprofil, innen

metric ISO-thread, full profile, internal

Gewinde-Ø ≥ 22 x 1.5 mm

thread-Ø ≥ 22 x 1.5 mm

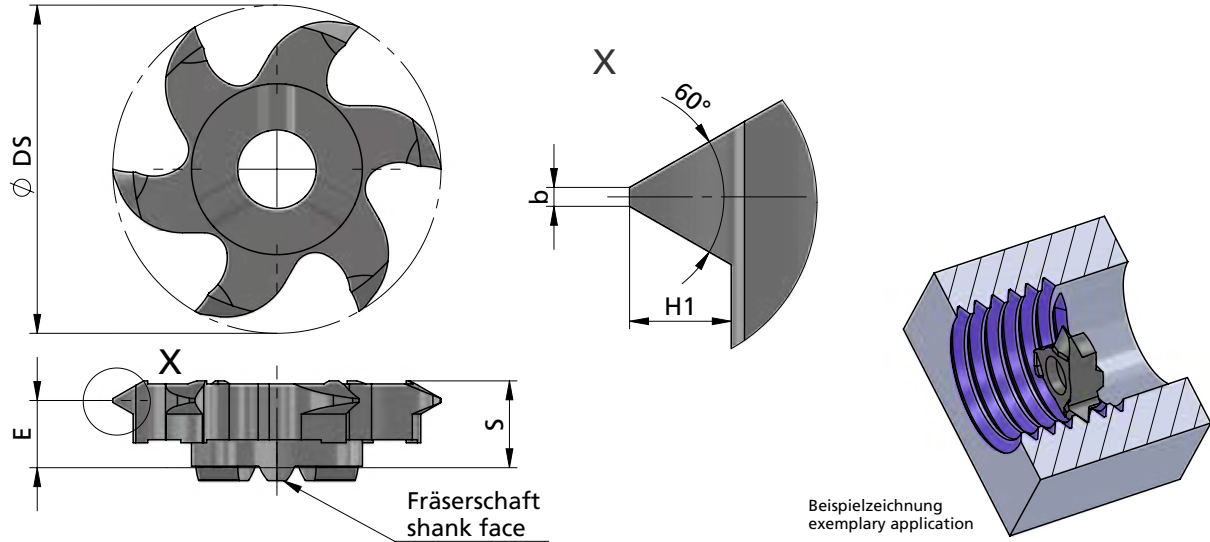

Abmessungen in mm

dimensions in mm

Bestellnummer part number	Steigung P pitch P	min. Gewinde-Ø min. thread-Ø	S	E	Ø DS	b	H1	Zähnezahl number of teeth				für Fräterschaft for milling shank
									K10F	AL41F	P18C	
Z618.0815.02	1.50	22	5.85	5.0	17.7	0.19	0.81	6	●			
Z618.1020.02	2.00	22	5.85	4.8	17.7	0.25	1.083	6	●			
Z618.1630.02	3.00	27	5.85	4.6	17.7	0.38	1.62	6	●			
Z618.1835.02	3.50	27	5.85	4.0	17.7	0.44	1.89	6	●			ZH18...

Weitere HM Sorten können Sie in der Sortenübersicht im Kapitel "Technische Hinweise" und der Preisliste finden.

Bestellbeispiel:
für Sorte AL41F:
Z618.0815.02/AL41F

More carbide grades you can find in the grades summary in the chapter "technical instructions" and in the price list.

order-example:
grade AL41F:
Z618.0815.02/AL41F

MINIMILL

Nut-, Formzirkular- und Trennfräsen

groove milling by circular interpolation, groove and slot milling

Typ Z22

metrisches ISO-Gewinde, Teilprofil, innen

metric ISO-thread, partial profile, internal

Gewinde-Ø ≥ 27 x 1.0 mm

thread-Ø ≥ 27 x 1.0 mm

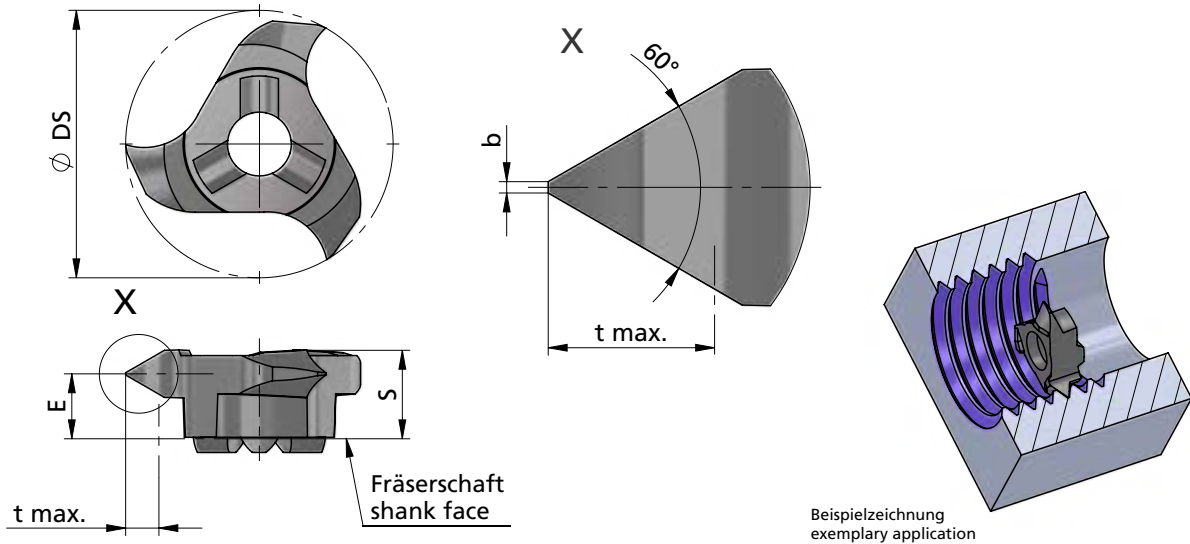

Abmessungen in mm

dimensions in mm



Bestellnummer part number	von Steigung P empfohlen as of pitch P recommended	bis Steigung P möglich up to pitch P possible	min. Gewinde-Ø min. thread-Ø	Abmessungen in mm			dimensions in mm			Zähnezahl number of teeth	K10F AL41F P18C	für Fräseschaft for milling shank
				S	E	Ø DS	b	t max.				
Z22.0720.01	1.0	2.00	27	5.85	4.6	21.7	0.12	1.19	3	●	ZH22...	
Z22.0815.01	1.5	2.75	27	5.85	4.5	21.7	0.18	1.62	3	●		
Z22.1020.01	2.0	3.75	27	5.85	4.2	21.7	0.25	2.22	3	●		
Z22.1630.01	2.5	5.00	30	5.85	3.8	21.7	0.31	2.98	3	●		
Z22.2140.01	3.5	6.00	30	5.85	3.4	21.7	0.44	3.52	3	●		
Z22.2445.01	3.5	6.50	30	5.85	3.2	21.7	0.44	3.84	3	●		
Z22.2545.01	2.5	4.50	27	5.85	3.7	21.7	0.31	2.71	3	●		

Weitere HM Sorten können Sie in der Sortenübersicht im Kapitel "Technische Hinweise" und der Preisliste finden.

Bestellbeispiel:
für Sorte AL41F:
Z22.0720.01/AL41F

More carbide grades you can find in the grades summary in the chapter "technical instructions" and in the price list.

order-example:
grade AL41F:
Z22.0720.01/AL41F

MINIMILL

Nut-, Formzirkular- und Trennfräsen

groove milling by circular interpolation, groove and slot milling

Typ Z622

metrisches ISO-Gewinde, Teilprofil, innen

metric ISO-thread, partial profile, internal

Gewinde-Ø ≥ 27 x 1.0 mm

thread-Ø ≥ 27 x 1.0 mm

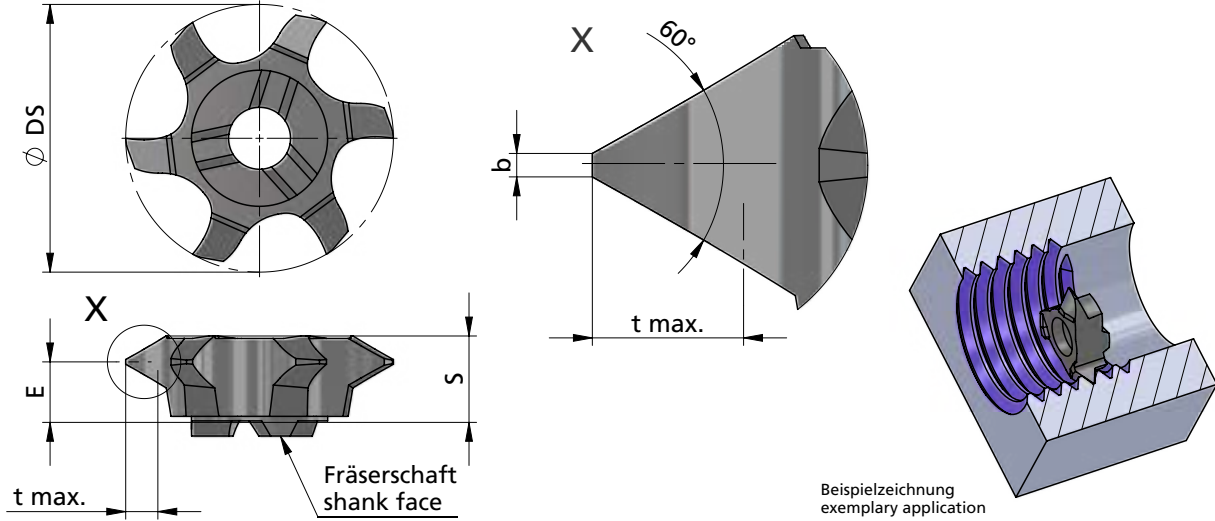

Beispielzeichnung
exemplary application

Abmessungen in mm

dimensions in mm

Bestellnummer part number	von Steigung P empfohlen as of pitch P recommended	bis Steigung P möglich up to pitch P possible	min. Gewinde-Ø min. thread-Ø	S	E	Ø DS	b	t max.	Zähnezahl number of teeth	K10F	AL41F	P18C	für Fräsertschaft for milling shank
Z622.0720.01	1.0	2.0	27	6.20	5.0	21.7	0.12	1.19	6	●			
Z622.2545.01	2.0	4.5	27	6.05	4.2	21.7	0.25	2.70	6	●			ZH22...

Weitere HM Sorten können Sie in der Sortenübersicht im Kapitel "Technische Hinweise" und der Preisliste finden.

Bestellbeispiel:
für Sorte AL41F:
Z622.0720.01/AL41F

More carbide grades you can find in the grades summary in the chapter "technical instructions" and in the price list.

order-example:
grade AL41F:
Z622.0720.01/AL41F

MINIMILL

Nut-, Formzirkular- und Trennfräsen

groove milling by circular interpolation, groove and slot milling

Typ Z22

metrisches ISO-Gewinde, Vollprofil, innen

metric ISO-thread, full profile, internal

Gewinde-Ø ≥ 24 x 1.5 mm

thread-Ø ≥ 24 x 1.5 mm

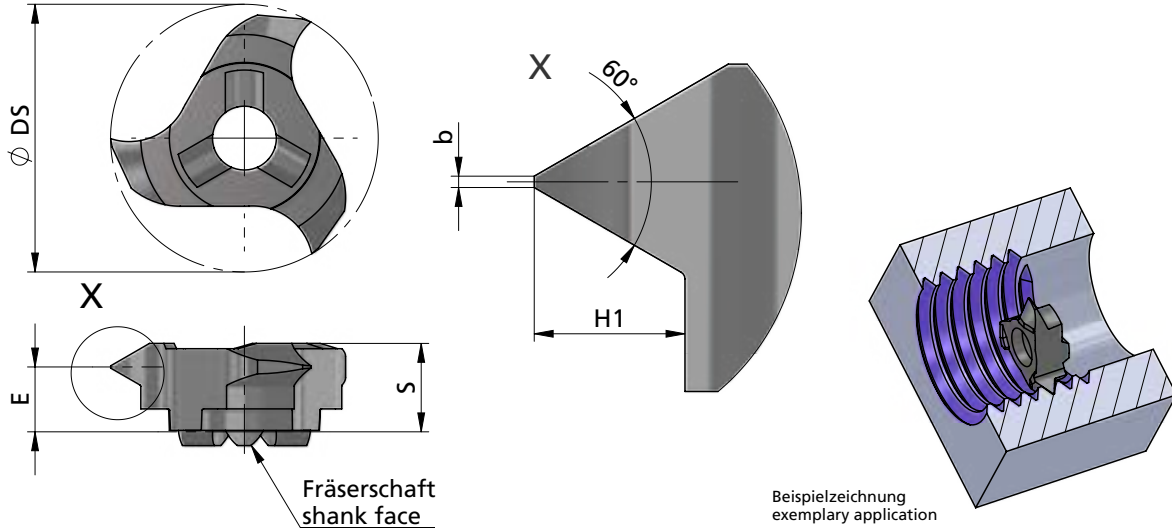

Abmessungen in mm

dimensions in mm



Bestellnummer part number	Steigung P pitch P	min. Gewinde-Ø min. thread-Ø	S	E	Ø DS	b	H1	Zähnezahl number of teeth	K10F AL41F P18C	für Fräaserschaft for milling shank
Z22.0815.02	1.50	24	5.85	4.8	21.7	0.19	0.81	3	●	ZH22...
Z22.0917.02	1.75	27	5.85	4.7	21.7	0.22	0.95	3	●	
Z22.1020.02	2.00	27	5.85	4.6	21.7	0.25	1.08	3	●	
Z22.1630.02	3.00	30	5.85	4.3	21.7	0.37	1.62	3	●	
Z22.1835.02	3.50	30	5.85	4.0	21.7	0.43	1.89	3	●	
Z22.2140.02	4.00	33	5.85	3.9	21.7	0.50	2.16	3	●	
Z22.2445.02	4.50	33	5.85	3.7	21.7	0.56	2.43	3	●	

Weitere HM Sorten können Sie in der Sortenübersicht im Kapitel "Technische Hinweise" und der Preisliste finden.

Bestellbeispiel:
für Sorte AL41F:
Z22.0815.02/AL41F

More carbide grades you can find in the grades summary in the chapter "technical instructions" and in the price list.

order-example:
grade AL41F:
Z22.0815.02/AL41F

MINIMILL

Nut-, Formzirkular- und Trennfräsen

groove milling by circular interpolation, groove and slot milling

Typ Z622

metrisches ISO-Gewinde, Vollprofil, innen

metric ISO-thread, full profile, internal

Gewinde-Ø ≥ 24 x 1.5 mm

thread-Ø ≥ 24 x 1.5 mm

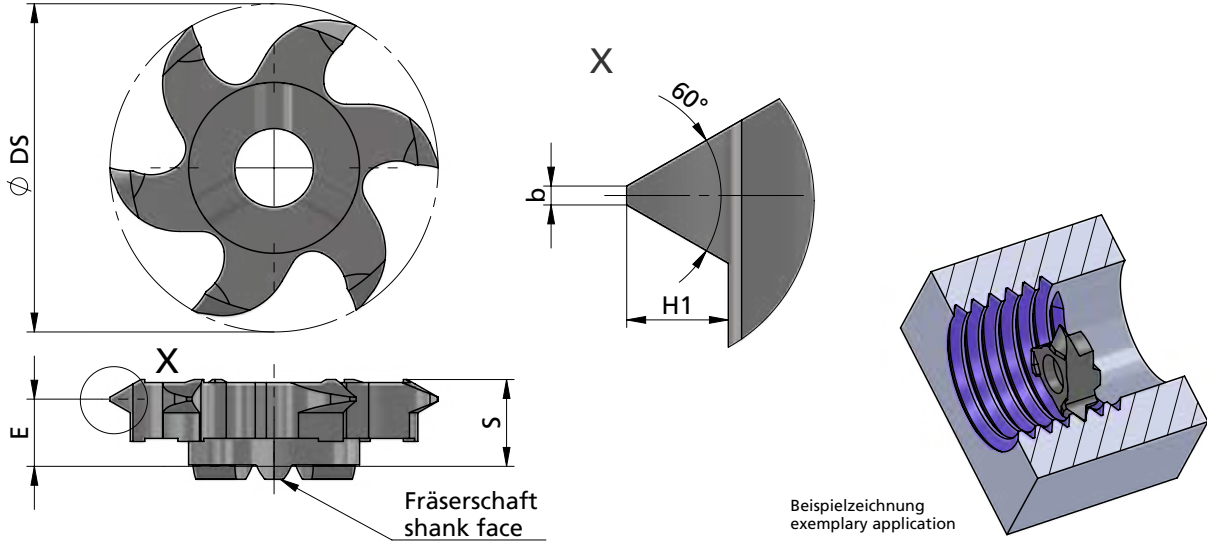

Abmessungen in mm

dimensions in mm

Bestellnummer part number	Steigung P pitch P	min. Gewinde-Ø min. thread-Ø	S	E	Ø DS	b	H1	Zähnezahl number of teeth	K10F AL41F P18C	für Fräaserschaft for milling shank
Z622.0815.02	1.50	24	6.2	5.3	21.7	0.19	0.81	6	●	ZH22...
Z622.0917.02	1.75	27	6.2	5.2	21.7	0.22	0.95	6	●	
Z622.1020.02	2.00	27	6.2	5.0	21.7	0.25	1.08	6	●	
Z622.1630.02	3.00	30	6.2	4.8	21.7	0.37	1.62	6	●	
Z622.2140.02	4.00	33	6.2	4.4	21.7	0.50	2.16	6	●	

Weitere HM Sorten können Sie in der Sortenübersicht im Kapitel "Technische Hinweise" und der Preisliste finden.

Bestellbeispiel:
für Sorte AL41F:
Z622.0815.02/AL41F

More carbide grades you can find in the grades summary in the chapter "technical instructions" and in the price list.

order-example:
grade AL41F:
Z622.0815.02/AL41F

MINIMILL

Nut-, Formzirkular- und Trennfräsen

groove milling by circular interpolation, groove and slot milling

Typ Z28

metrisches ISO-Gewinde, Teilprofil, innen

metric ISO-thread, partial profile, internal

Gewinde-Ø ≥ 33 x 1.0 mm

thread-Ø ≥ 33 x 1.0 mm

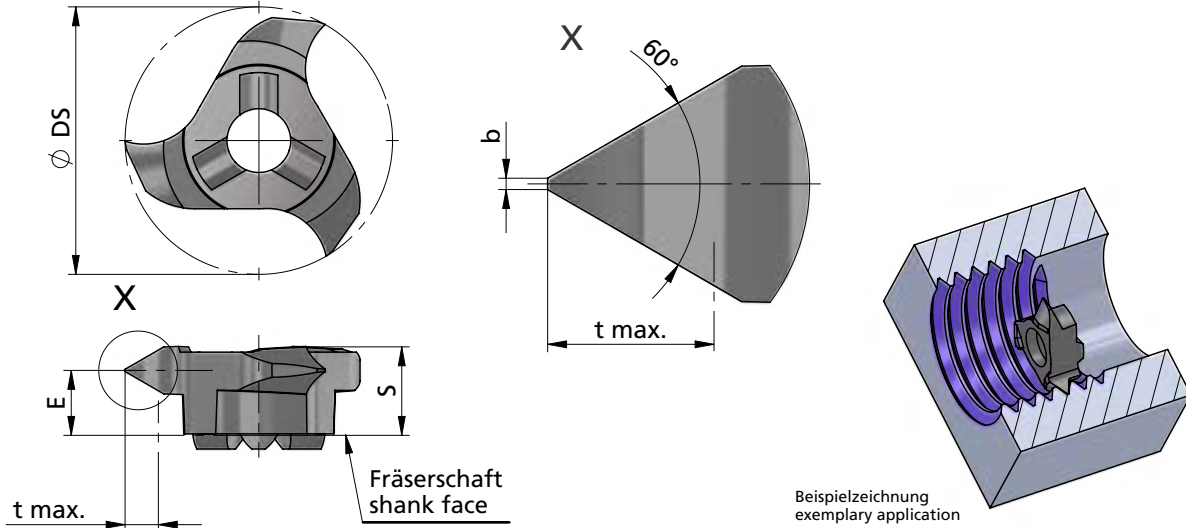

Abmessungen in mm

dimensions in mm



Bestellnummer part number	von Steigung P empfohlen as of pitch P recommended	bis Steigung P möglich up to pitch P possible	min. Gewinde-Ø min. thread-Ø	Abmessungen in mm			dimensions in mm			Zähnezahl number of teeth	K10F AL41F P18C	für Fräterschaft for milling shank
				S	E	Ø DS	b	t max.				
Z28.0720.01	1.0	2.0	33	6.6	4.6	27.7	0.12	1.20	3	●	ZH28...	
Z28.1525.01	1.5	2.5	33	6.6	4.3	27.7	0.18	1.49	3	●		
Z28.3050.01	2.5	5.0	36	6.6	4.1	27.7	0.37	2.93	3	●		
Z28.5060.01	4.0	6.0	39	6.6	3.6	27.7	0.50	4.60	3	●		

Weitere HM Sorten können Sie in der Sortenübersicht im Kapitel "Technische Hinweise" und der Preisliste finden.

Bestellbeispiel:
für Sorte AL41F:
Z28.0720.01/AL41F

More carbide grades you can find in the grades summary in the chapter "technical instructions" and in the price list.

order-example:
grade AL41F:
Z28.0720.01/AL41F

MINIMILL

Nut-, Formzirkular- und Trennfräsen

groove milling by circular interpolation, groove and slot milling

Typ Z628

metrisches ISO-Gewinde, Teilprofil, innen

metric ISO-thread, partial profile, internal

Gewinde-Ø ≥ 33 x 1.5 mm

thread-Ø ≥ 33 x 1.5 mm

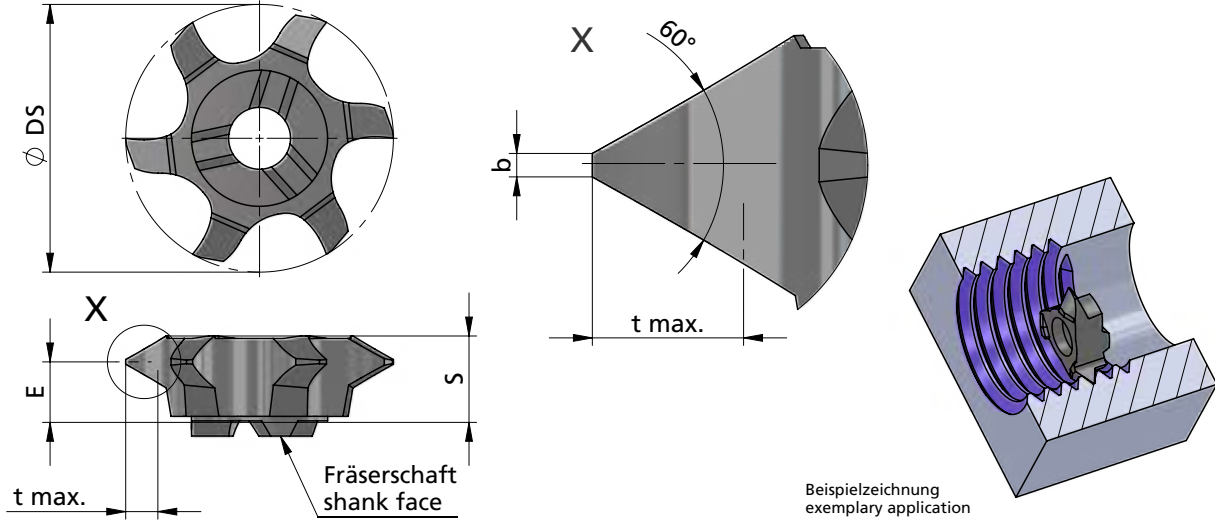

Abmessungen in mm

dimensions in mm

Bestellnummer part number	von Steigung P empfohlen as of pitch P recommended	bis Steigung P möglich up to pitch P possible	min. Gewinde-Ø min. thread-Ø	S	E	Ø DS	b	t max.	Zähnezahl number of teeth	K10F AL41F P18C	für Fräsertschaft for milling shank
Z628.1525.01	1.5	2.5	33	6.5	5.0	27.7	0.19	1.60	6	●	ZH28...
Z628.3050.01	2.5	5.0	36	6.1	3.9	27.7	0.38	2.93	6	●	

Weitere HM Sorten können Sie in der Sortenübersicht im Kapitel "Technische Hinweise" und der Preisliste finden.

Bestellbeispiel:
für Sorte AL41F:
Z628.1525.01/AL41F

More carbide grades you can find in the grades summary in the chapter "technical instructions" and in the price list.

order-example:
grade AL41F:
Z628.1525.01/AL41F

MINIMILL

Nut-, Formzirkular- und Trennfräsen

groove milling by circular interpolation, groove and slot milling

Typ Z622

metrisches ISO-Gewinde, Vollprofil, außen

metric ISO-thread, full profile, external

Steigung P 1.5 - 4.0 mm

pitch P 1.5 - 4.0 mm

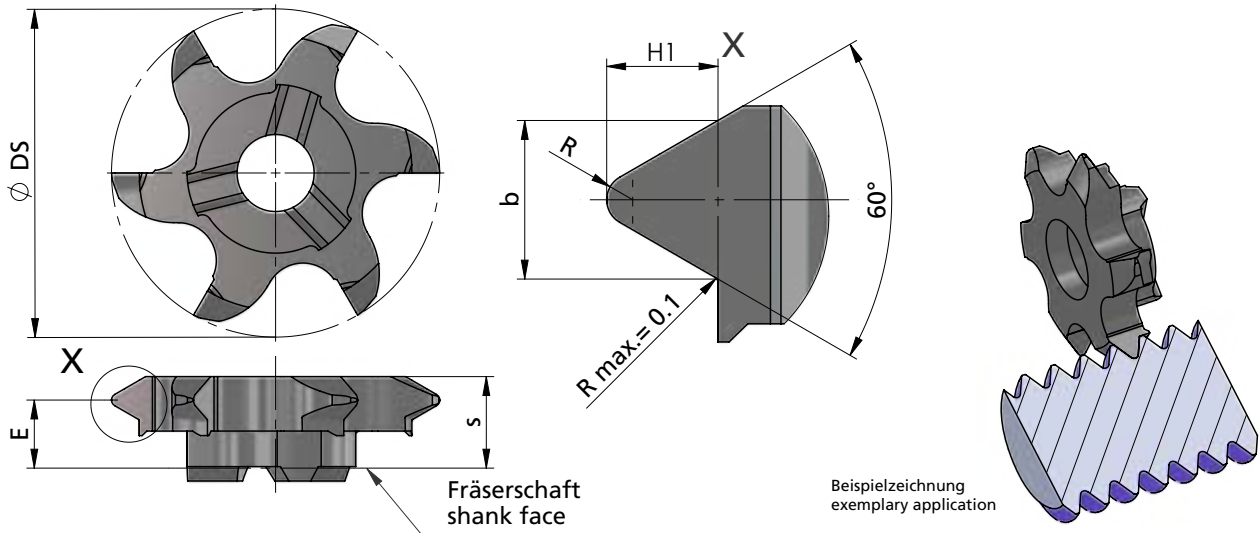

Abmessungen in mm

dimensions in mm

Bestellnummer part number	Steigung P pitch P	S	E	R	$\varnothing DS$	$b \pm 0.01$	H1	Zähnezahl number of teeth	K10F AL41F P18C	für Frälerschaft for milling shank
Z622.E0815.02	1.50	6.25	5.35	0.22	21.7	1.316	0.92	6	●	ZH22...
Z622.E0917.02	1.75	6.25	5.25	0.25	21.7	1.524	1.07	6	●	
Z622.E1020.02	2.00	6.25	5.10	0.29	21.7	1.755	1.23	6	●	
Z622.E1630.02	3.00	6.05	4.50	0.43	21.7	2.621	1.84	6	●	
Z622.E2140.02	4.00	6.05	4.00	0.58	21.7	3.499	2.45	6	●	

Weitere HM Sorten können Sie in der Sortenübersicht im Kapitel "Technische Hinweise" und der Preisliste finden.

Bestellbeispiel:
für Sorte AL41F:
Z622.E0815.02/AL41F

More carbide grades you can find in the grades summary in the chapter "technical instructions" and in the price list.

order-example:
grade AL41F:
Z622.E0815.02/AL41F

MINIMILL

Nut-, Formzirkular- und Trennfräsen

groove milling by circular interpolation, groove and slot milling

Typ Z12

Whitworth-Gewinde, Vollprofil, innen

Whitworth thread, full profile, internal

Gewinde-Ø ≥ 15.1 mm

thread-Ø ≥ 15.1 mm

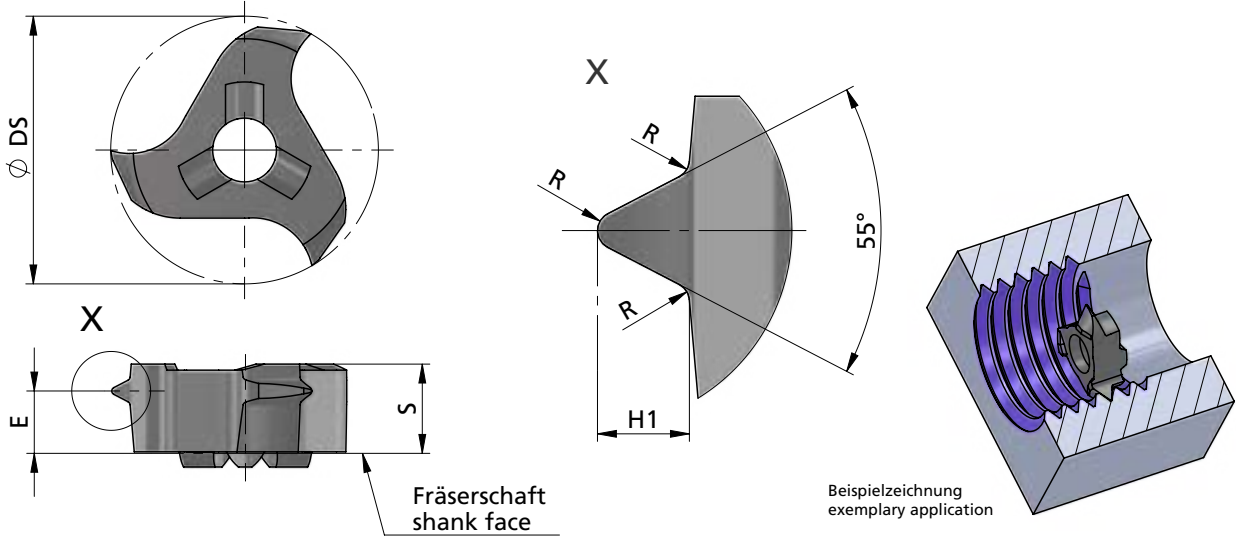

Abmessungen in mm

dimensions in mm

Bestellnummer part number	Gang / Zoll threads / inch	min. Gewinde-Ø min. thread-Ø	min. Gewindegröße min. thread size						Zähnezahl number of teeth	K10F AL41F P18C	für Fräaserschaft for milling shank
				S	E	Ø DS	H1	R			
Z12.0813.19	19	15.1	G 3/8"	3.6	2.5	11.7	0.86	0.18	3	●	
Z12.1118.14	14	17.5	G 1/2"	3.6	2.3	11.7	1.16	0.24	3	●	ZH10...
Z12.1423.11	11	18.8	G 1"	3.6	2.0	11.7	1.48	0.31	3	●	

Weitere HM Sorten können Sie in der Sortenübersicht im Kapitel "Technische Hinweise" und der Preisliste finden.

More carbide grades you can find in the grades summary in the chapter "technical instructions" and in the price list.

MINIMILL

Nut-, Formzirkular- und Trennfräsen

groove milling by circular interpolation, groove and slot milling

Typ Z614

Whitworth-Gewinde, Vollprofil, innen

Whitworth thread, full profile, internal

Gewinde-Ø ≥ 17.5 mm

thread-Ø ≥ 17.5 mm

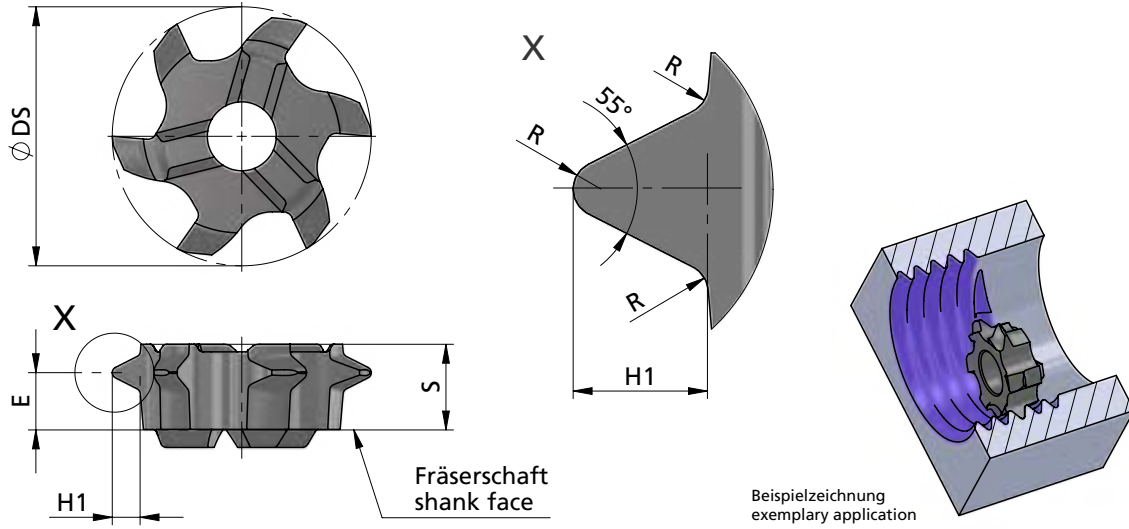

Beispielzeichnung
exemplary application



Abmessungen in mm

dimensions in mm

Bestellnummer part number	Gang / Zoll threads / inch	min. Gewinde-Ø min. thread-Ø	min. Gewindegröße min. thread size	dimensions in mm						Zähnezahl number of teeth	K10F AL41F P18C	für Fräterschaft for milling shank
				S	E	Ø DS	H1	R				
Z614.5514.02	14	17.5	G 1/2"	4.6	3.3	13.7	1.16	0.24	6	●	ZH14...	
Z614.5511.02	11	18.8	G 1"	4.6	3.1	13.7	1.48	0.31	6	●		

Weitere HM Sorten können Sie in der Sortenübersicht im Kapitel "Technische Hinweise" und der Preisliste finden.

Bestellbeispiel:
für Sorte AL41F:
Z614.5514.02/AL41F

More carbide grades you can find in the grades summary in the chapter "technical instructions" and in the price list.

order-example:
grade AL41F:
Z614.5514.02/AL41F

MINIMILL

Nut-, Formzirkular- und Trennfräsen

groove milling by circular interpolation, groove and slot milling

Typ Z16

Whitworth-Gewinde, Vollprofil, innen

Whitworth thread, full profile, internal

Gewinde-Ø ≥ 22.0 mm

thread-Ø ≥ 22.0 mm

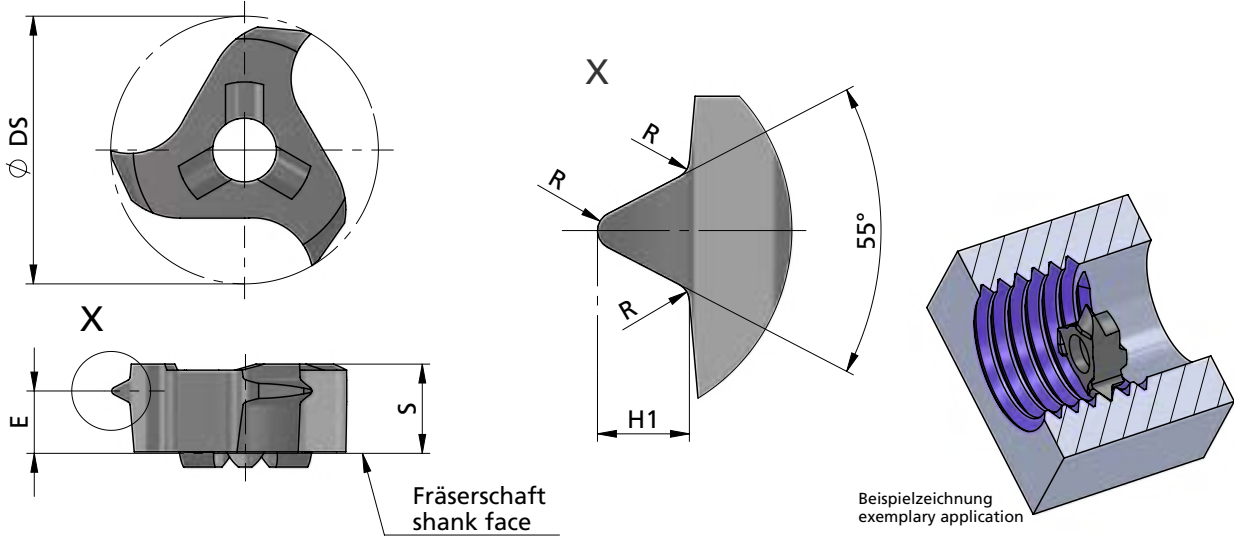

Abmessungen in mm

dimensions in mm

Bestellnummer part number	Gang / Zoll threads / inch	min. Gewinde-Ø min. thread-Ø	min. Gewindegröße min. thread size	Abmessungen in mm / dimensions in mm					Zähnezahl number of teeth	K10F AL41F P18C	für Fräaserschaft for milling shank
				S	E	Ø DS	H1	R			
Z16.5514.02	14	22.0	G 5/8"	4.5	3.0	15.7	1.17	0.24	3	●	ZH14...
Z16.5511.02	11	23.5	G 1"	4.5	2.8	15.7	1.48	0.31	3	●	

Weitere HM Sorten können Sie in der Sortenübersicht im Kapitel "Technische Hinweise" und der Preisliste finden.

Bestellbeispiel:
für Sorte AL41F:
Z16.5514.02/AL41F

More carbide grades you can find in the grades summary in the chapter "technical instructions" and in the price list.

order-example:
grade AL41F:
Z16.5514.02/AL41F

MINIMILL

Nut-, Formzirkular- und Trennfräsen

groove milling by circular interpolation, groove and slot milling

Typ Z18

Whitworth-Gewinde, Vollprofil, innen

Whitworth thread, full profile, internal

Gewinde-Ø ≥ 25.6 mm

thread-Ø ≥ 25.6 mm

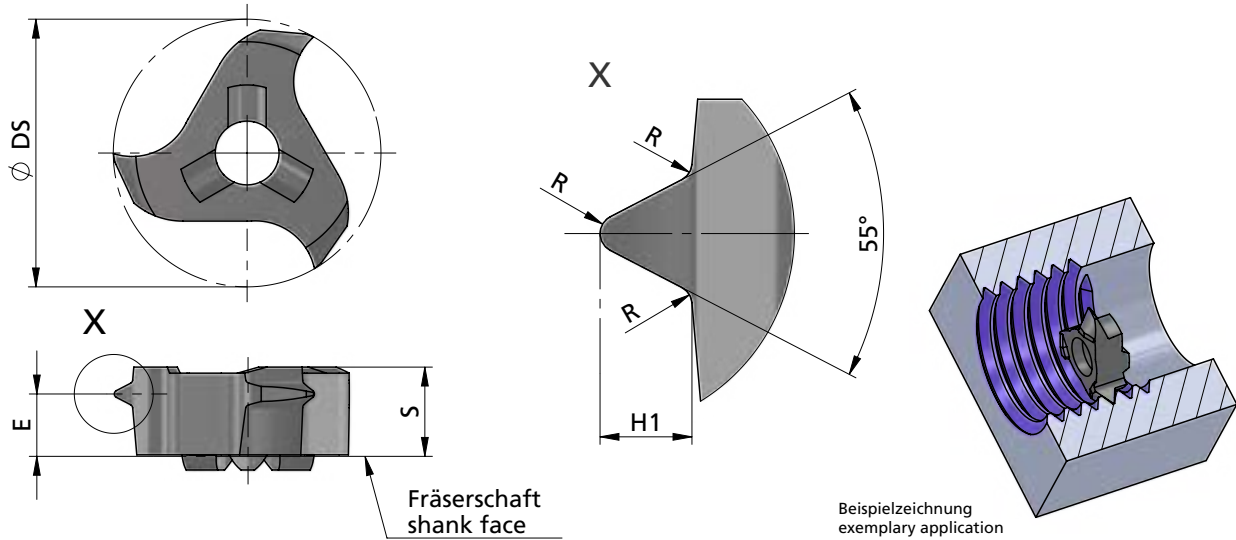

Abmessungen in mm

dimensions in mm



Bestellnummer part number	Gang / Zoll threads / inch	min. Gewinde-Ø min. thread-Ø	min. Gewindegröße min. thread size	S	E	Ø DS	H1	R	Zähnezahl number of teeth	K10F AL41F P18C	für Fräterschaft for milling shank
Z18.5511.02	11	25.6	G 1"	5.85	4.4	17.7	1.480	0.32	3	●	
Z18.5514.02	14	24.0	G 3/4"	5.85	4.6	17.7	1.160	0.25	3	●	ZH18...
Z18.5519.02	19	22.8	-	5.85	4.9	17.7	0.857	0.18	3	●	

Weitere HM Sorten können Sie in der Sortenübersicht im Kapitel "Technische Hinweise" und der Preisliste finden.

Bestellbeispiel:
für Sorte AL41F:
Z18.5519.02/AL41F

More carbide grades you can find in the grades summary in the chapter "technical instructions" and in the price list.

order-example:
grade AL41F:
Z18.5519.02/AL41F

MINIMILL

Nut-, Formzirkular- und Trennfräsen

groove milling by circular interpolation, groove and slot milling

Typ Z22

Whitworth-Gewinde, Vollprofil, innen

Whitworth thread, full profile, internal

Gewinde-Ø ≥ 38.3 mm

thread-Ø ≥ 38.3 mm

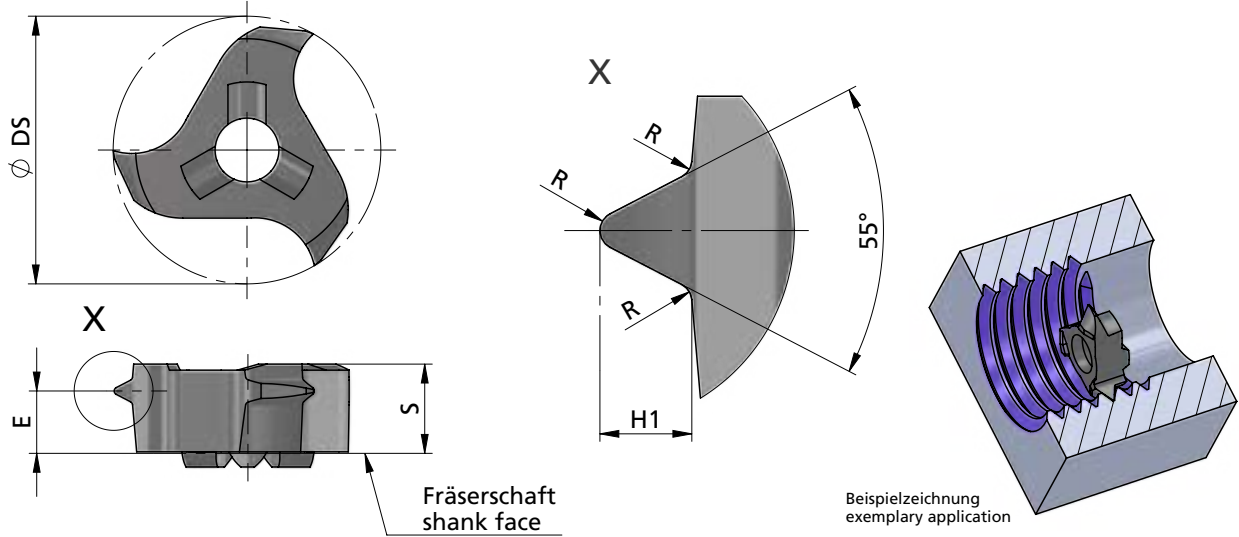

Abmessungen in mm

dimensions in mm

Bestellnummer part number	Gang / Zoll threads / inch	min. Gewinde-Ø min. thread-Ø	min. Gewindegröße min. thread size	Abmessungen in mm / dimensions in mm					Zähnezahl number of teeth	K10F AL41F P18C	für Fräaserschaft for milling shank
				S	E	Ø DS	H1	R			
Z22.5506.02	6	38.3	BSW 1 1/2"	5.85	3.1	21.7	2.71	0.58	3	●	ZH22...
Z22.5508.02	8	32.7	-	5.85	3.5	21.7	2.03	0.43	3	●	
Z22.5511.02	11	30.0	G 1"	5.85	4.0	21.7	1.48	0.31	3	●	

Weitere HM Sorten können Sie in der Sortenübersicht im Kapitel "Technische Hinweise" und der Preisliste finden.

Bestellbeispiel:
für Sorte AL41F:
Z22.5508.02/AL41F

More carbide grades you can find in the grades summary in the chapter "technical instructions" and in the price list.

order-example:
grade AL41F:
Z22.5508.02/AL41F

MINIMILL

Nut-, Formzirkular- und Trennfräsen

groove milling by circular interpolation, groove and slot milling

Typ Z622

Whitworth-Gewinde, Vollprofil, innen

Whitworth thread, full profile, internal

Gewinde-Ø ≥ 38.3 mm

thread-Ø ≥ 38.3 mm

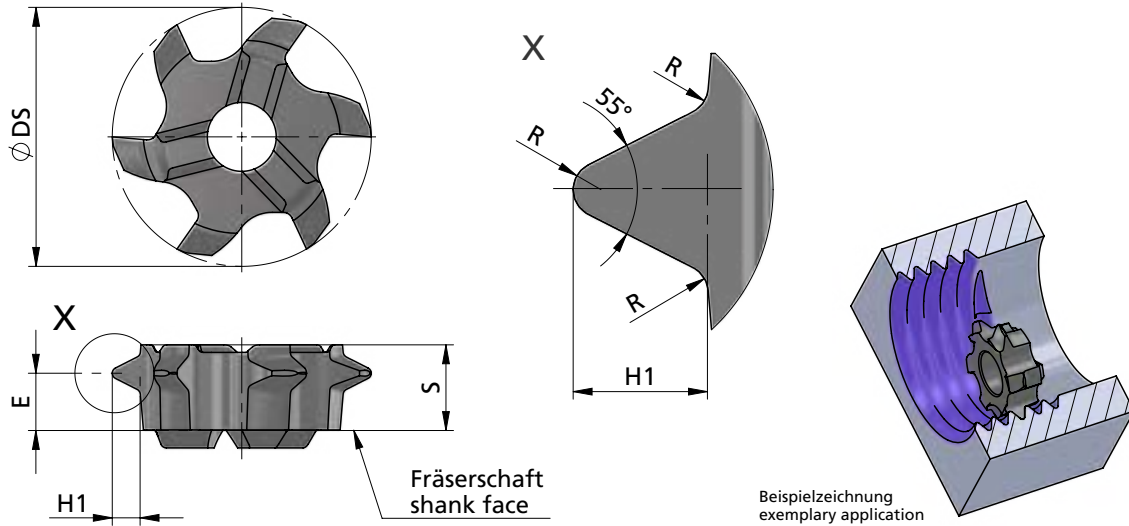

Frälerschaft
shank face

Beispielzeichnung
exemplary application

Abmessungen in mm

dimensions in mm

Bestellnummer part number	Gang / Zoll threads / inch	min. Gewinde-Ø min. thread-Ø	min. Gewindegröße min. thread size	S	E	Ø DS	H1	R	Zähnezahl number of teeth	K10F AL41F P18C	für Frälerschaft for milling shank
Z622.5506.02	6	38.3	BSW 1 1/2"	6.05	3.8	21.7	2.71	0.58	6	●	
Z622.5508.02	8	32.7	-	6.31	4.2	21.7	2.03	0.43	6	●	ZH22...
Z622.5511.02	11	30.0	G 1"	6.35	4.8	21.7	1.48	0.31	6	●	

Weitere HM Sorten können Sie in der Sortenübersicht im Kapitel "Technische Hinweise" und der Preisliste finden.

Bestellbeispiel:
für Sorte AL41F:
Z622.5506.02/AL41F

More carbide grades you can find in the grades summary in the chapter "technical instructions" and in the price list.

order-example:
grade AL41F:
Z622.5506.02/AL41F

MINIMILL

Nut-, Formzirkular- und
Trennfräsen

groove milling by
circular interpolation,
groove and slot milling

Impressionen

impressions



MINIMILL

Nut-, Formzirkular- und Trennfräsen

groove milling by circular interpolation, groove and slot milling

Typ Z10 / Z12

Vorwärts- und Rückwärtsfasen

forward & backward chamfering

D min. 10 / 12 mm

D min. 10 / 12 mm

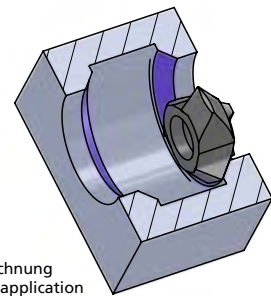
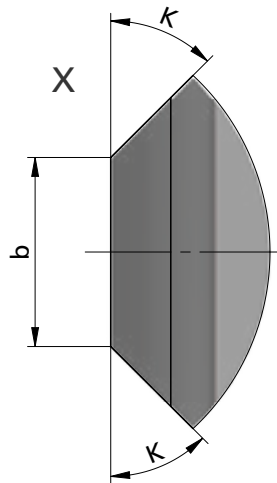
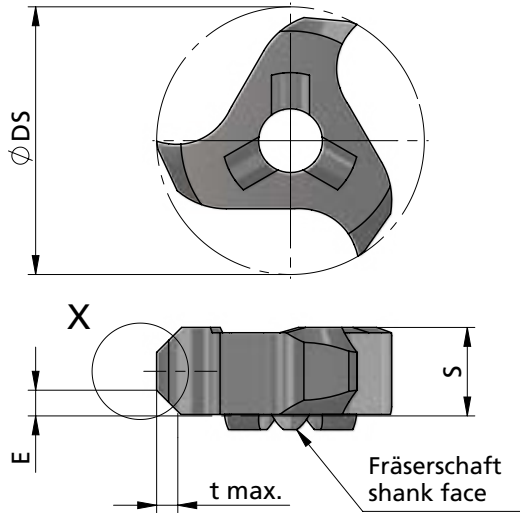

Beispielzeichnung
exemplary application



Abmessungen in mm

dimensions in mm

Bestellnummer part number	K	D min.	S	E	Ø DS	b	t max.	Zähnezahl number of teeth	Material			für Fräaserschaft for milling shank
									K10F	AL41F	P18C	
Z10.4545.35	45°	10	3.5	1.4	9.7	0.9	1.0	3	●			
Z12.4545.35	45°	12	3.5	1.2	11.7	1.2	0.8	3	●			ZH10...

Weitere HM Sorten können Sie in der Sortenübersicht im Kapitel "Technische Hinweise" und der Preisliste finden.

Bestellbeispiel:
für Sorte AL41F:
Z12.4545.35/AL41F

More carbide grades you can find in the grades summary in the chapter "technical instructions" and in the price list.

order-example:
grade AL41F:
Z12.4545.35/AL41F

MINIMILL

Nut-, Formzirkular- und Trennfräsen

groove milling by circular interpolation, groove and slot milling

Typ Z610

Vorwärts- und Rückwärtsfasen

forward & backward chamfering

D min. 10 mm

D min. 10 mm

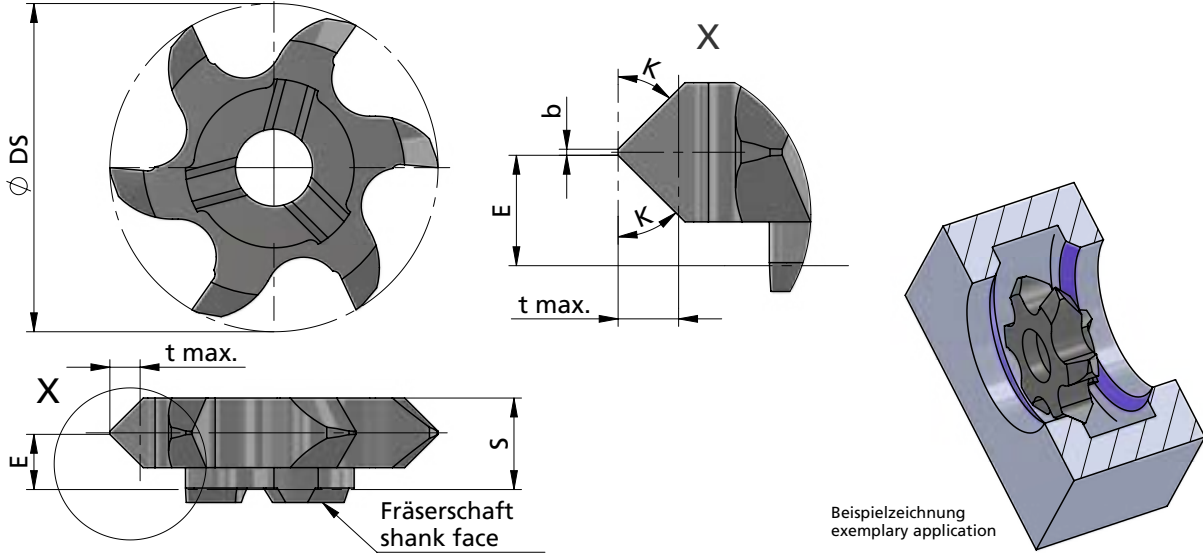

Beispielzeichnung
exemplary application

Abmessungen in mm

dimensions in mm

Bestellnummer part number	K	D min.	S	E	Ø DS	b	t max.	Zähnezahl number of teeth	Material			für Fräseschaft for milling shank
									K10F	AL41F	P18C	
Z610.1515.02	15°	10	3.6	1.8	9.7	0.2	0.35	6	●			ZH10...
Z610.2020.02	20°	10	3.6	1.8	9.7	0.2	0.45	6	●			
Z610.3030.02	30°	10	3.6	1.8	9.7	0.2	0.7	6	●			
Z610.4545.02	45°	10	3.6	1.8	9.7	0.2	1.2	6	●			

Weitere HM Sorten können Sie in der Sortenübersicht im Kapitel "Technische Hinweise" und der Preisliste finden.

Bestellbeispiel:
für Sorte AL41F:
Z610.1515.02/AL41F

More carbide grades you can find in the grades summary in the chapter "technical instructions" and in the price list.

order-example:
grade AL41F:
Z610.1515.02/AL41F

MINIMILL

Nut-, Formzirkular- und Trennfräsen

groove milling by circular interpolation, groove and slot milling

Typ Z614

Vorwärts- und Rückwärtsfasen

forward & backward chamfering

D min. 14 mm

D min. 14 mm

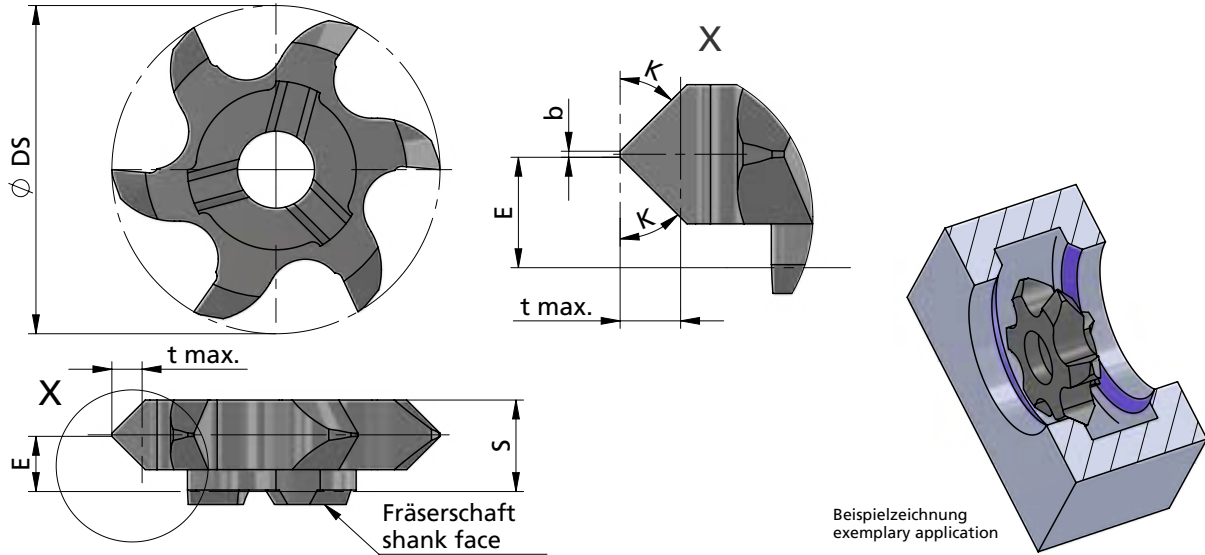

Abmessungen in mm

dimensions in mm



Bestellnummer part number	K	D min.	S	E	Ø DS	b	t max.	Zähnezahl number of teeth	Material			für Fräseschaft for milling shank
									K10F	AL41F	P18C	
Z614.1515.02	15°	14	4.6	2.3	13.7	0.2	0.35	6	●			
Z614.2020.02	20°	14	4.6	2.3	13.7	0.2	0.45	6	●			
Z614.3030.02	30°	14	4.6	2.3	13.7	0.2	0.7	6	●			
Z614.4545.02	45°	14	4.6	2.3	13.7	0.2	1.8	6	●			ZH14...

Weitere HM Sorten können Sie in der Sortenübersicht im Kapitel "Technische Hinweise" und der Preisliste finden.

Bestellbeispiel:
für Sorte AL41F:
Z614.1515.02/AL41F

More carbide grades you can find in the grades summary in the chapter "technical instructions" and in the price list.

order-example:
grade AL41F:
Z614.1515.02/AL41F

MINIMILL

Nut-, Formzirkular- und Trennfräsen

groove milling by circular interpolation, groove and slot milling

Typ Z16

Vorwärts- und Rückwärtsfasen

forward & backward chamfering

D min. 16 mm

D min. 16 mm

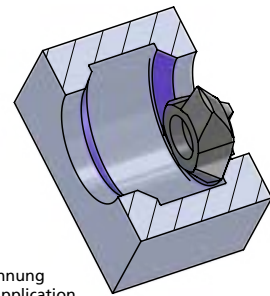
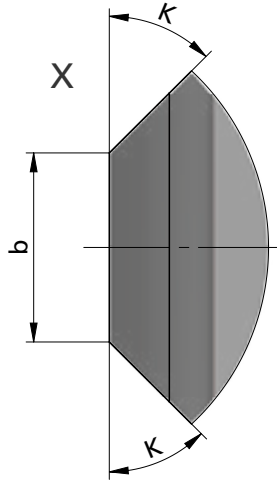
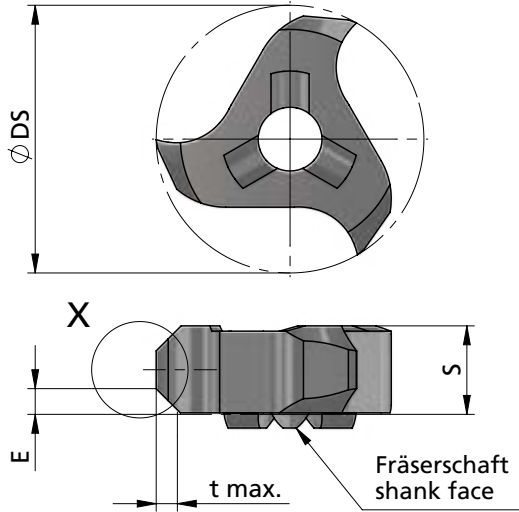

Beispielzeichnung
exemplary application

Abmessungen in mm

dimensions in mm

Bestellnummer part number	K	D min.	S	E	Ø DS	b	t max.	Zähnezahl number of teeth	K10F AL41F P18C	für Frärschaft for milling shank
Z16.4545.35	45°	16	4.5	1.6	15.7	1.4	1.4	3	●	
Z16.4545.02	45°	16	4.5	2.2	15.7	0.2	1.8	3	●	ZH14...

Weitere HM Sorten können Sie in der Sortenübersicht im Kapitel "Technische Hinweise" und der Preisliste finden.

Bestellbeispiel:
für Sorte AL41F:
Z16.4545.35/AL41F

More carbide grades you can find in the grades summary in the chapter "technical instructions" and in the price list.

order-example:
grade AL41F:
Z16.4545.35/AL41F

MINIMILL

Nut-, Formzirkular- und Trennfräsen

groove milling by circular interpolation, groove and slot milling

Typ Z18

Vorwärts- und Rückwärtsfasen

forward & backward chamfering

D min. 15 mm

D min. 15 mm

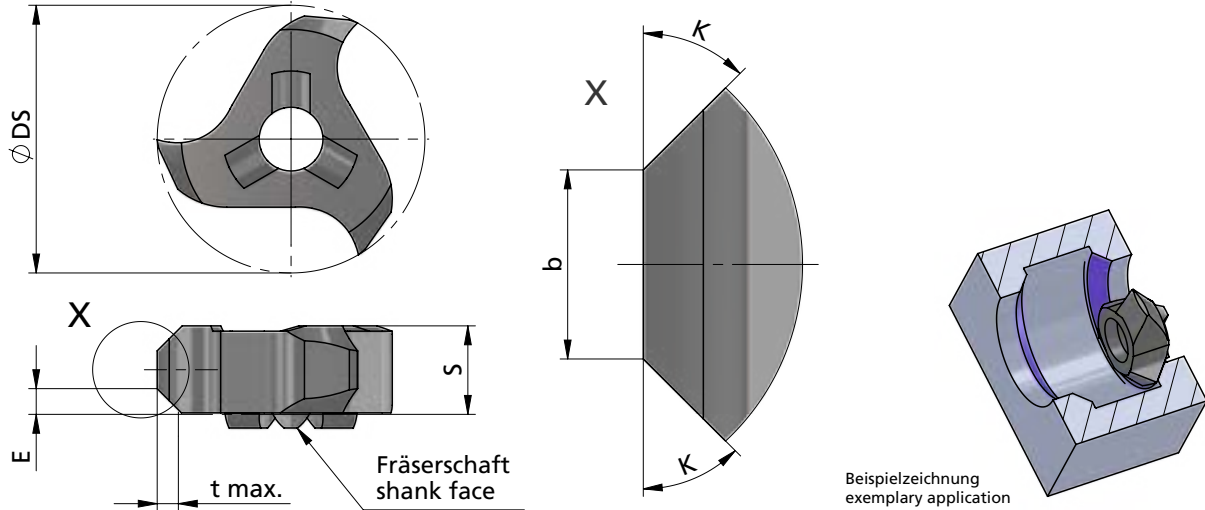

Abmessungen in mm

dimensions in mm



Bestellnummer part number	K	D min.	S	E	$\varnothing DS$	b	t max.	Zähnezahl number of teeth	K10F AL41F P18C	für Fräterschaft for milling shank
Z18.4545.DS15	45°	15	5.85	2.9	14.7	0.2	2.5	3	●	
Z18.4545.58	45°	18	5.85	1.75	17.7	2.5	1.4	3	●	ZH18...

Weitere HM Sorten können Sie in der Sortenübersicht im Kapitel "Technische Hinweise" und der Preisliste finden.

Bestellbeispiel:
für Sorte AL41F:
Z18.4545.58/AL41F

More carbide grades you can find in the grades summary in the chapter "technical instructions" and in the price list.

order-example:
grade AL41F:
Z18.4545.58/AL41F

MINIMILL

Nut-, Formzirkular- und Trennfräsen

groove milling by circular interpolation, groove and slot milling

Typ Z18

Vorwärts- und Rückwärtsfasen mit Radius

forward & backward chamfering with radius

D min. 18 mm

D min. 18 mm

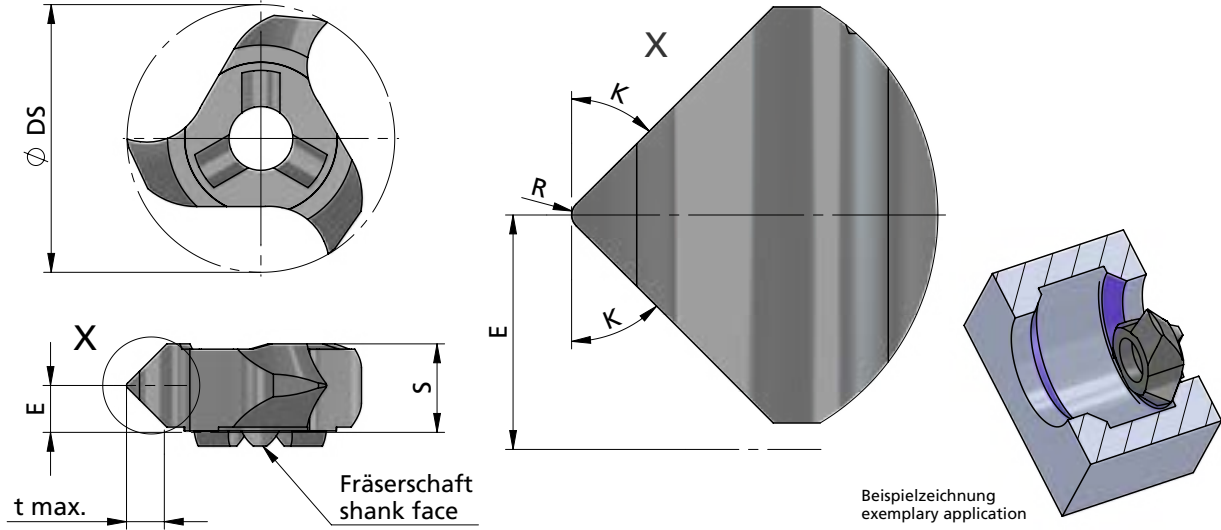

Abmessungen in mm

dimensions in mm

Bestellnummer part number	K	D min.	S	E	R	$\varnothing DS$	t max.	Zähnezahl number of teeth	K10F AL41F P18C	für Fräseschaft for milling shank
Z18.4545.02	45°	18	5.85	3.0	0.2	17.7	2.5	3	●	ZH18...

Weitere HM Sorten können Sie in der Sortenübersicht im Kapitel "Technische Hinweise" und der Preisliste finden.

Bestellbeispiel:
für Sorte AL41F:
Z18.4545.02/AL41F

More carbide grades you can find in the grades summary in the chapter "technical instructions" and in the price list.

order-example:
grade AL41F:
Z18.4545.02/AL41F

MINIMILL

Nut-, Formzirkular- und Trennfräsen

groove milling by circular interpolation, groove and slot milling

Typ Z22

Vorwärts- und Rückwärtsfasen

forward & backward chamfering

D min. 22 mm

D min. 22 mm

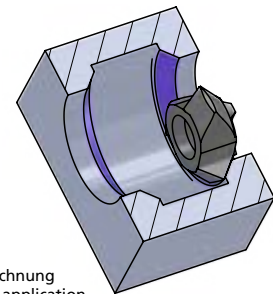
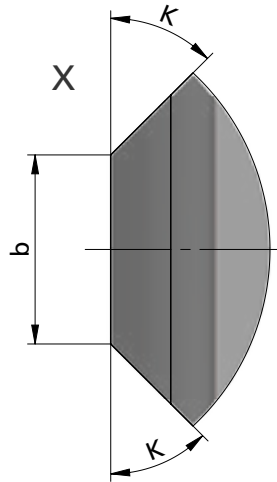
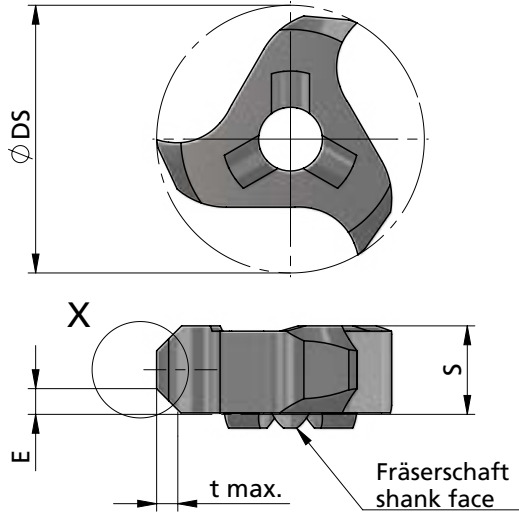

Beispielzeichnung
exemplary application



Abmessungen in mm

dimensions in mm

Bestellnummer part number	K	D min.	S	E	Ø DS	b	t max.	Zähnezahl number of teeth	Material			für Frärschaft for milling shank
									K10F	AL41F	P18C	
Z22.4545.58	45°	22	5.85	2.0	21.7	2.0	1.7	3	●			
Z22.4545.94 *	45°	22	9.4	3.25	21.7	3.0	3.0	3	●			ZH22...

Weitere HM Sorten können Sie in der Sortenübersicht im Kapitel "Technische Hinweise" und der Preisliste finden.

*Achtung: für diesen Schneideinsatz Sonderschraube A.SP5028

Best.beisp.: für Sorte AL41F: Z22.4545.58/AL41F

More carbide grades you can find in the grades summary in the chapter "technical instructions" and in the price list.

*attention: this insert needs special screw A.SP5028

order-example: grade AL41F: Z22.4545.58/AL41F

MINIMILL

Nut-, Formzirkular- und Trennfräsen

groove milling by circular interpolation, groove and slot milling

Typ Z618 / Z622 / Z628

Vorwärts- und Rückwärtsfasen

forward & backward chamfering

D min. 15 - 28 mm

D min. 15 - 28 mm

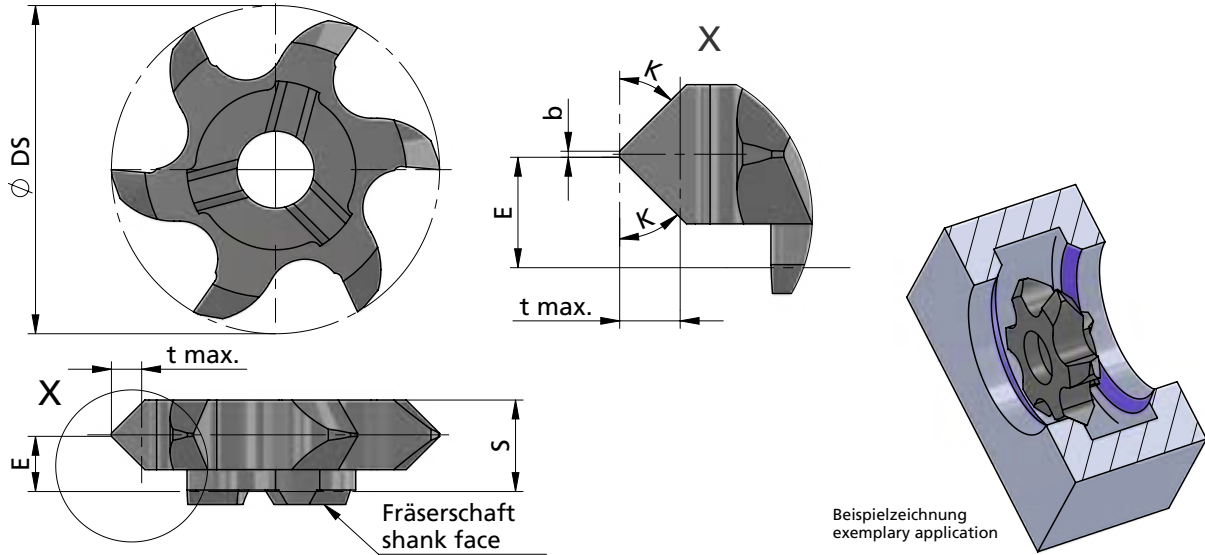

Abmessungen in mm

dimensions in mm

Bestellnummer part number	K	D min.	S	E	$\varnothing DS$	b	t max.	Zähnezahl number of teeth				für Frärschaft for milling shank
									K10F	AL41F	P18C	
Z618.3030.02	30°	18	5.85	2.9	17.7	0.2	1.5	6	●			ZH18...
Z618.4545.DS15	45°	15	5.75	2.75	14.7	0.5	1.6	6	●			ZH18...
Z618.4545.58	45°	18	5.75	2.9	17.7	0.2	2.2	6	●			ZH18...
Z622.4545.63	45°	22	6.05	3.7	21.7	0.2	2.0	6	●			ZH22...
Z628.4545.02	45°	28	6.50	3.7	27.7	0.2	2.0	6	●			ZH28...

Weitere HM Sorten können Sie in der Sortenübersicht im Kapitel "Technische Hinweise" und der Preisliste finden.

Bestellbeispiel:
für Sorte AL41F:
Z618.3030.02/AL41F

More carbide grades you can find in the grades summary in the chapter "technical instructions" and in the price list.

order-example:
grade AL41F:
Z618.3030.02/AL41F

MINIMILL

Nut-, Formzirkular- und Trennfräsen

groove milling by circular interpolation, groove and slot milling

Typ Z620 / Z628

Stirn- und Planfräsen

face milling

D min. 20 / 28 mm

D min. 20 / 28 mm

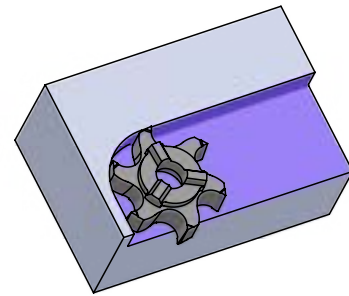
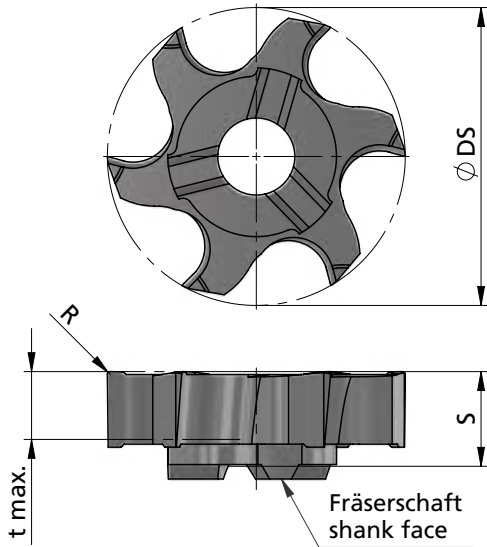

Beispielzeichnung
exemplary application



Abmessungen in mm

dimensions in mm

Bestellnummer part number	D min.	S	R	Ø DS	t max.	Zähnezahl number of teeth	Material			für Frälerschaft for milling shank
							K10F	AL41F	P18C	
Z620.SP50.02	20	6.2	0.2	19.7	5.0	6	●			ZH22...
Z628.SP50.02	28	6.2	0.2	27.7	5.0	6	●			ZH28...

Weitere HM Sorten können Sie in der Sortenübersicht im Kapitel "Technische Hinweise" und der Preisliste finden.

Bestellbeispiel:
für Sorte AL41F:
Z620.SP50.02/AL41F

More carbide grades you can find in the grades summary in the chapter "technical instructions" and in the price list.

order-example:
grade AL41F:
Z620.SP50.02/AL41F

MINIMILL

Nut-, Formzirkular- und
Trennfräsen

groove milling by
circular interpolation,
groove and slot milling

Sets

D min. 12 mm

D min. 18 mm



Bestellnummer
part number

Inhalt
Content

K10F
AL41F
P18C

SET-MINI-MILLZ12

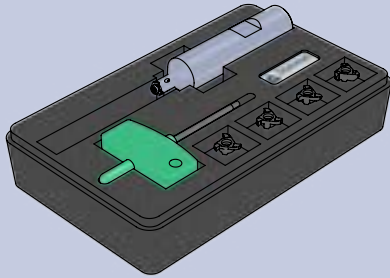

- Sicherungsringe DIN471/472 und Nutfräsen allgemein
- Nutfräsen Vollradius
- Vorwärts- und Rückwärtsfasen

- for circlips DIN471/472, groove milling general use
- groove milling full radius
- forward & backward chamfering

Fräseschaft /
milling shank:

1 x ZH10.1606.12.B.ST

Schneideinsatz / insert:

1 x Z12.0150.02

1 x Z12.0200.00

1 x Z12.0011.22

1 x Z12.4545.35



Bestellnummer
part number

Inhalt
Content

K10F
AL41F
P18C

SET-MINI-MILLZ18

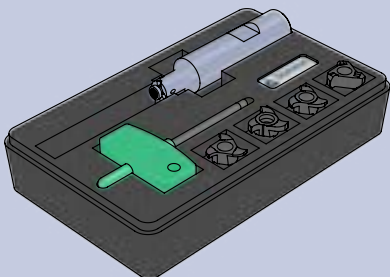

- Sicherungsringe DIN471/472 und Nutfräsen allgemein
- Nutfräsen Vollradius
- Vorwärts- und Rückwärtsfasen

- for circlips DIN471/472, groove milling general use
- groove milling full radius
- forward & backward chamfering

Fräseschaft /
milling shank:

1 x ZH18.1609.18.B.ST

Schneideinsatz / insert:

1 x Z18.0150.00

1 x Z18.0300.02

1 x Z18.0011.22

1 x Z18.4545.58



MINIMILL

Nut-, Formzirkular- und
Trennfräsen

groove milling by
circular interpolation,
groove and slot milling

Sets

D min. 22 mm

D min. 37 mm

	Bestellnummer part number	Inhalt Content	K10F AL41F P18C
	<p>SET-MINI-MILLZ22</p> <ul style="list-style-type: none"> • Nutfräsen allgemein • Nutfräsen Vollradius • Vorwärts- und Rückwärtsfasen <ul style="list-style-type: none"> • groove milling general use • groove milling full radius • forward & backward chamfering 	<p>Frälerschaft / milling shank:</p> <p>1 x ZH22.1612.24.B.ST</p> <p>Schneideinsatz / insert:</p> <p>1 x Z622.0150.01 1 x Z622.0400.02 1 x Z22.0014.28 1 x Z22.4545.58</p>	<p>● ● ● ●</p>

	Bestellnummer part number	Inhalt Content	K10F AL41F P18C
	<p>SET-MINI-MILLZ637</p> <ul style="list-style-type: none"> • Nutfräsen allgemein • Spannschraube Klemmhalter <ul style="list-style-type: none"> • groove milling general use • screw milling shank 	<p>Frälerschaft / milling shank:</p> <p>1 x ZH22.1612.24.B.ST</p> <p>Schneideinsatz / insert:</p> <p>2 x Z637.0150.01</p> <p>Spannschraube / screw:</p> <p>1x A.SPS029</p>	<p>●</p>



MINIMILL XL

Nut- und Trennfräsen

groove and slot milling

Typ XH50

Fräferschaft Stahl

milling shank steel

Ø DS 50

Ø DS 50

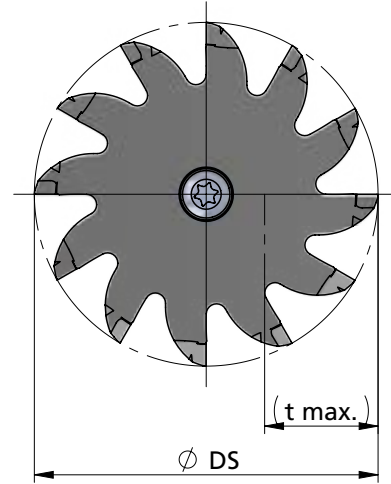
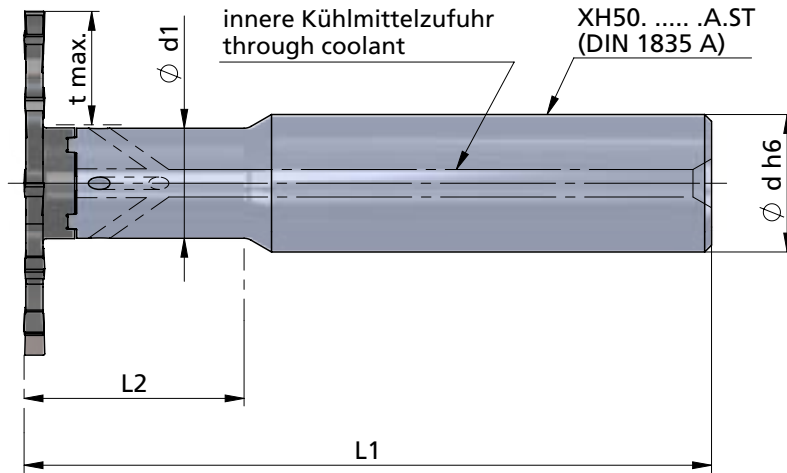

Beispielzeichnung
exemplary application

Abmessungen in mm

dimensions in mm



Bestellnummer part number	Ø d h6	Ø d (inch)	Ø d1	L1	L2	Typ: t max./ Schneidkreis-Ø DS	Spannschraube screw	Schraubenschlüssel wrench	Anzugs- drehmoment torque	für Schneideinsatz for insert
XH50.2016.32.A.ST	20		16	100	32					

MINIMILL XL

Nut- und Trennfräsen

groove and slot milling

Typ XH50

Frälerschaft Hartmetall

Ø DS 50

milling shank carbide

Ø DS 50

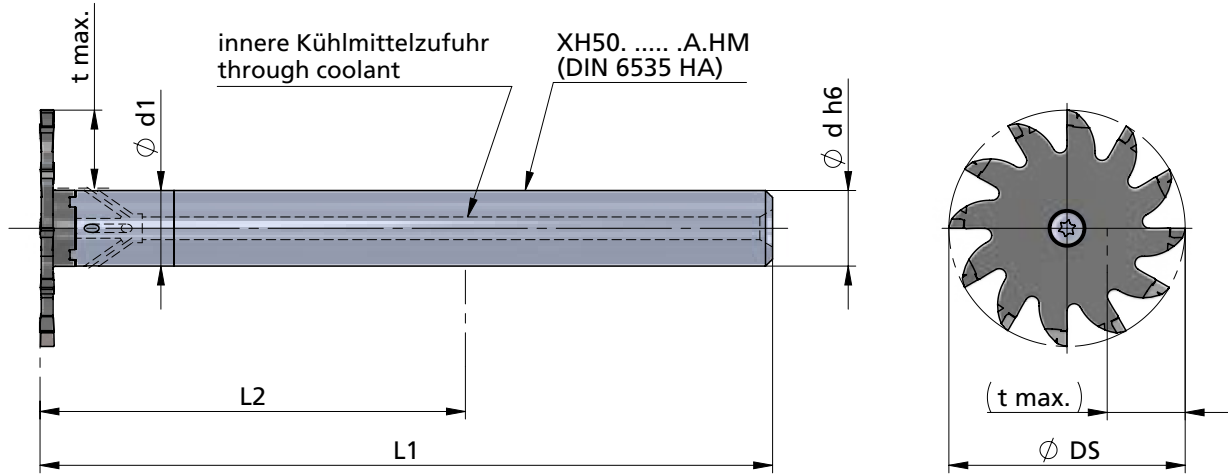

Beispielzeichnung
exemplary application



Abmessungen in mm

dimensions in mm

Bestellnummer part number	Ø d h6	Ø d (inch)	Ø d1	L1	L2	Typ: t max./ Schneidkreis-Ø DS	Spannschraube screw	Schraubenschlüssel wrench	Anzugs- drehmoment torque	für Schneideinsatz for insert
XH50.U1516.060.A.HM	15.87	5/8"	16	125	60	X1250: 16.5 / 50	A.SPS028	T20T-P	7.0 Nm	X1250...
XH50.U1516.090.A.HM	15.87	5/8"	16	155	90					
XH50.U1516.120.A.HM	15.87	5/8"	16	185	120					
XH50.1616.060.A.HM	16		16	125	60					
XH50.1616.090.A.HM	16		16	155	90					
XH50.1616.120.A.HM	16		16	185	120					

Bestellbeispiel:
XH50.U1516.060.A.HM

order-example:
XH50.U1516.060.A.HM

MINIMILL XL

Nut- und Trennfräsen

groove and slot milling

Typ X1250

Nut- und Trennfräsen

groove and slot milling

Ø DS 50
t max. = 16.5
b = 0.5 - 1.0

Ø DS 50
t max. = 16.5
b = 0.5 - 1.0

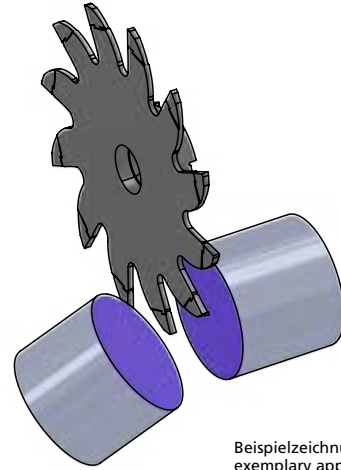
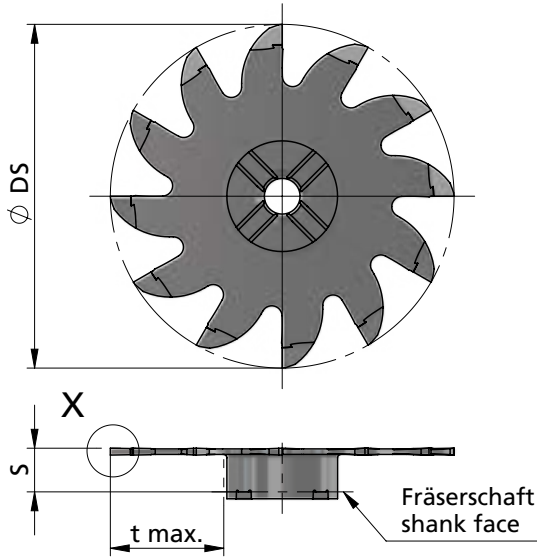

Beispielzeichnung
exemplary application

Abmessungen in mm

dimensions in mm

Bestellnummer part number	Ø DS	S	b ±0.02	t max.	Zähnezahl number of teeth	K10F P04C		für Fräserschaft for milling shank
						●	●	
X1250.0050.00	50	6.35	0.5	16.5	12	●	●	XH50...
X1250.0100.00	50	6.35	1.0	16.5	12	●	●	

Weitere HM Sorten können Sie in der Sortenübersicht im Kapitel "Technische Hinweise" und der Preisliste finden.

Bestellbeispiel:
für Sorte P04C:
X1250.0050.00/P04C

More carbide grades you can find in the grades summary in the chapter "technical instructions" and in the price list.

order-example:
grade P04C:
X1250.0050.00/P04C

MINIMILL XL

Nut- und Trennfräsen

groove and slot milling

Typ X1250.X

Nut- und Trennfräsen

groove and slot milling

Ø DS 50
t max. = 16.5
b = 1.17 - 3.5

Ø DS 50
t max. = 16.5
b = 1.17 - 3.5

X1250.X kreuzverzahnt / staggered-toothed

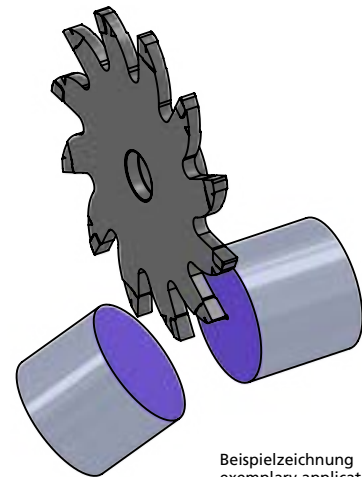
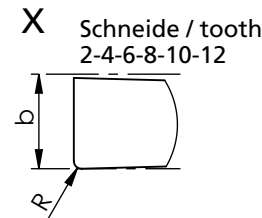
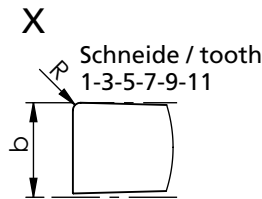
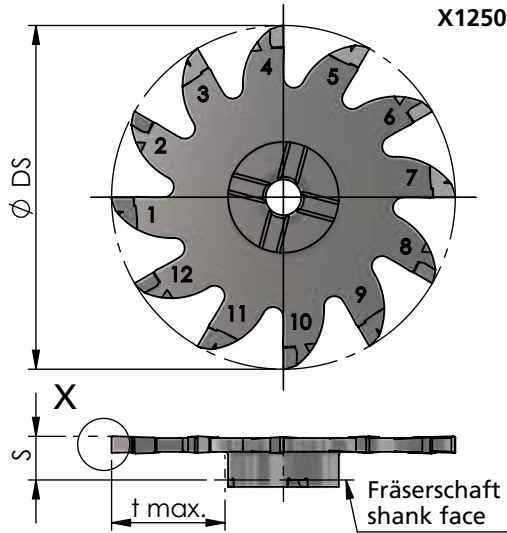

Beispielzeichnung
exemplary application



Abmessungen in mm

dimensions in mm

Bestellnummer part number	Ø DS	S	R	b ±0.02	b (inch)	t max.	Zähnezahl number of teeth	Material		für Frälerschaft for milling shank
								K10F	P04C	
X1250.X117.01	50	6.35	0.1	1.17	0.046"	16.5	12	●	●	XH50...
X1250.X150.01	50	6.35	0.1	1.50		16.5	12	●	●	
X1250.X157.01	50	6.35	0.1	1.57	0.062"	16.5	12	●	●	
X1250.X200.02	50	6.35	0.2	2.00		16.5	12	●	●	
X1250.X238.02	50	6.35	0.2	2.38	0.094"	16.5	12	●	●	
X1250.X250.02	50	6.35	0.2	2.50		16.5	12	●	●	
X1250.X300.02	50	6.35	0.2	3.00		16.5	12	●	●	
X1250.X318.02	50	6.35	0.2	3.17	0.125"	16.5	12	●	●	
X1250.X350.02	50	6.35	0.2	3.50		16.5	12	●	●	

Weitere HM Sorten können Sie in der Sortenübersicht im Kapitel "Technische Hinweise" und der Preisliste finden.

Bestellbeispiel:
für Sorte P04C:
X1250.X117.01/P04C

More carbide grades you can find in the grades summary in the chapter "technical instructions" and in the price list.

order-example:
grade P04C:
X1250.X117.01/P04C

MINIMILL XL

Nut- und Trennfräsen

groove and slot milling

Typ X1250.X

Nut- und Trennfräsen
mit Schnittkraftreduzierung

groove and slot milling
with cutting force reduction

Ø DS 50
t max. = 16.5
b ≥ 4

Ø DS 50
t max. = 16.5
b ≥ 4

X1250.X kreuzverzahnt / staggered-toothed

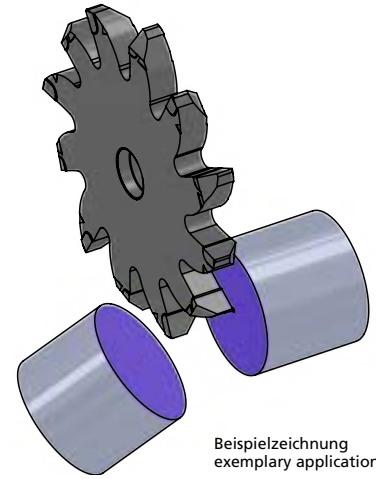
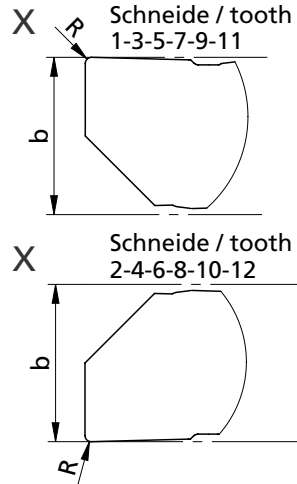
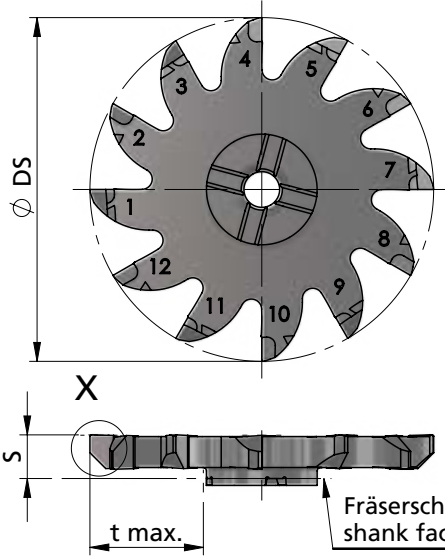

Abmessungen in mm

dimensions in mm

Bestellnummer part number	Ø DS	S	R	b ±0.02	b (inch)	t max.	Zähnezahl number of teeth	Material		für Fräterschaft for milling shank
								K10F	P04C	
X1250.X400.02	50	6.35	0.2	4.00		16.5	12	●	●	XH50...
X1250.X476.02	50	6.35	0.2	4.76	0.187"	16.5	12	●	●	
X1250.X500.02	50	6.35	0.2	5.00		16.5	12	●	●	
X1250.X600.02	50	6.35	0.2	6.00		16.5	12	●	●	

Weitere HM Sorten können Sie in der Sortenübersicht im Kapitel "Technische Hinweise" und der Preisliste finden.

Bestellbeispiel:
für Sorte P04C:
X1250.X400.02/P04C

More carbide grades you can find in the grades summary in the chapter "technical instructions" and in the price list.

order-example:
grade P04C:
X1250.X400.02/P04C

MINIMILL XL

Nut- und Trennfräsen

groove and slot milling

Typ X1250.L6

Trennfräsen
mit 6° Schräge

slot milling
with 6° lead angle

Ø DS 50
t max. = 16.5
b = 1.0 - 2.0

Ø DS 50
t max. = 16.5
b = 1.0 - 2.0

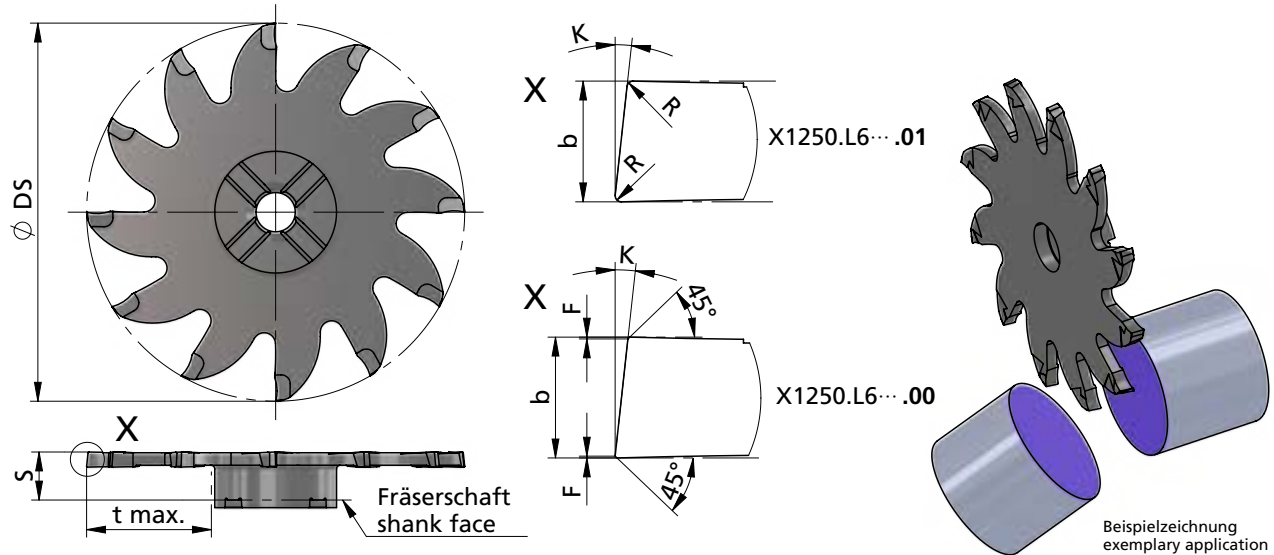

Beispielzeichnung
exemplary application

Abmessungen in mm

dimensions in mm



Bestellnummer part number	Ø DS	S	R	F	K	b ±0.02	t max.	Zähnezahl number of teeth	K10F P04C	für Fräseschaft for milling shank
X1250.L610.00	50	5.85		0.03	6°	1.0	16.5	12	● ●	XH50...
X1250.L610.01	50	5.85	0.1		6°	1.0	16.5	12	● ●	
X1250.L615.00	50	6.35		0.03	6°	1.5	16.5	12	● ●	
X1250.L615.01	50	6.35	0.1		6°	1.5	16.5	12	● ●	
X1250.L620.00	50	6.35		0.03	6°	2.0	16.5	12	● ●	
X1250.L620.01	50	6.35	0.1		6°	2.0	16.5	12	● ●	

Weitere HM Sorten können Sie in der Sortenübersicht im Kapitel "Technische Hinweise" und der Preisliste finden.

Bestellbeispiel:
für Sorte P04C:
X1250.L610.00/P04C

More carbide grades you can find in the grades summary in the chapter "technical instructions" and in the price list.

order-example:
grade P04C:
X1250.L610.00/P04C

MINIMILL

Nut-, Formzirkular- und
Trennfräsen

groove milling by
circular interpolation,
groove and slot milling

Technische Hinweise

Grundsätzliche Informationen zum Gewindefräsen

Technical instructions,
basic informations about thread milling

Vor- und Nachschnitt

Beim Zirkularfräsen von Gewinden entsteht durch die Steigung ein Vor- und Nachschnitt. Um hier die Verletzung des Gewindeprofils so gering wie möglich zu halten muß ein Werkzeug mit einem möglichst kleinen Schneidkreis gewählt werden.

Die nachfolgende Skizze zeigt die Verhältnisse bei der Bearbeitung:

(Grün: Konturverletzung X gering = gut; Rot: Konturverletzung X erheblich = schlecht)

Thread profile violation

Thread milling by interpolation causes a profile violation. To keep the violation minimal you should use the cutting circle as small as possible.

The following sketch shows the relations during the process:

(green: profile violation X low = good; red: profile violation X big = bad)

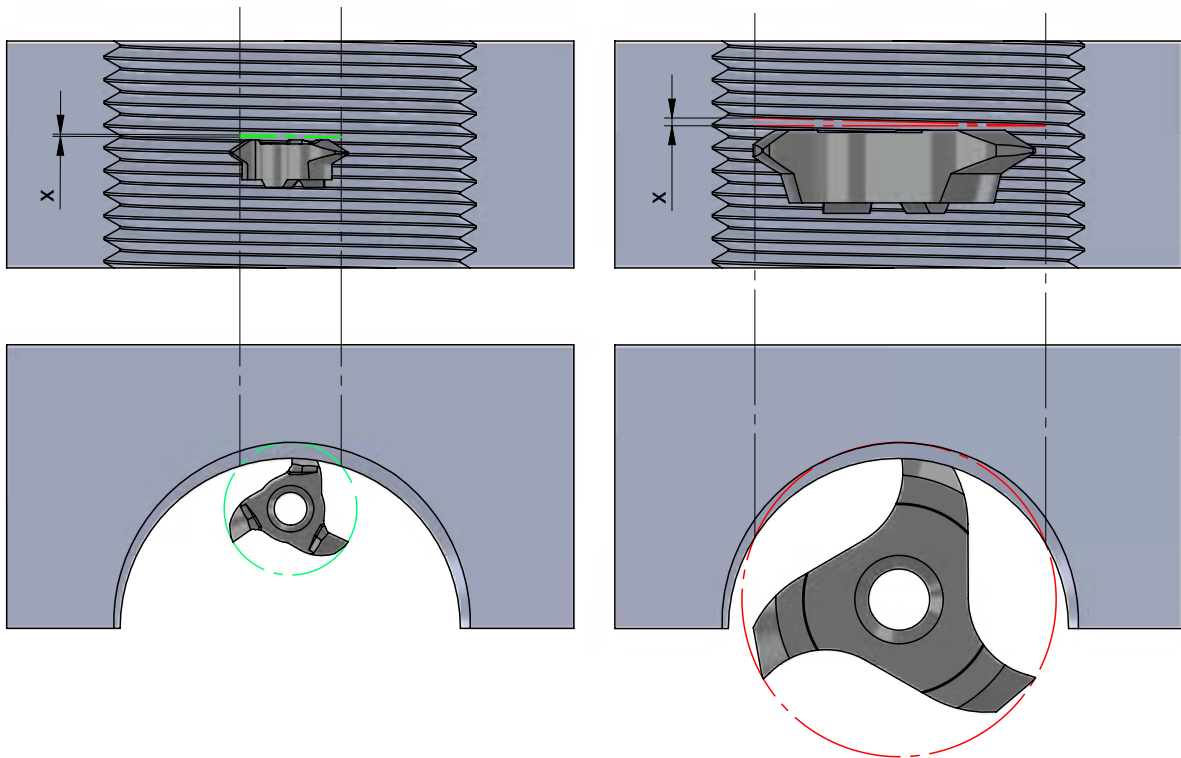

MINIMILL

Nut-, Formzirkular- und
Trennfräsen

groove milling by
circular interpolation,
groove and slot milling

Technische Hinweise

Grundsätzliche Informationen zum Gewindefräsen

Technical instructions,
basic informations about thread milling

Teilprofil

Werkzeuge mit Teilprofil sind Mehrbereichswerkzeuge, d.h. mit diesem Werkzeug können Gewinde mit unterschiedlichen Steigungen hergestellt werden. Dies ist aber nur mit einer kleinen Abweichung vom Normprofil möglich. Abgestimmt ist das Werkzeug auf die kleinste angegebene Steigung, dieses Profil kann ohne Abweichung produziert werden. Alle weiteren Steigungen können ebenfalls produziert werden, hier weicht aber das gefertigte Profil gegenüber der Norm durch eine höhere Gewindetiefe ab. In der Regel ist dies unproblematisch, muß aber gegebenenfalls im Einzelfall genauer betrachtet werden.

Partial profile

Tools with partial profile are multi-purpose tools, that means you can process several pitches with one tool. The processed shape has a small difference to the standard profile. Created is that tool for the smallest pitch, this profile depends to the standard.

All other pitches are producible, but only with a small deviation. Normally this causes no problem, but sometimes you have to decide case by case.

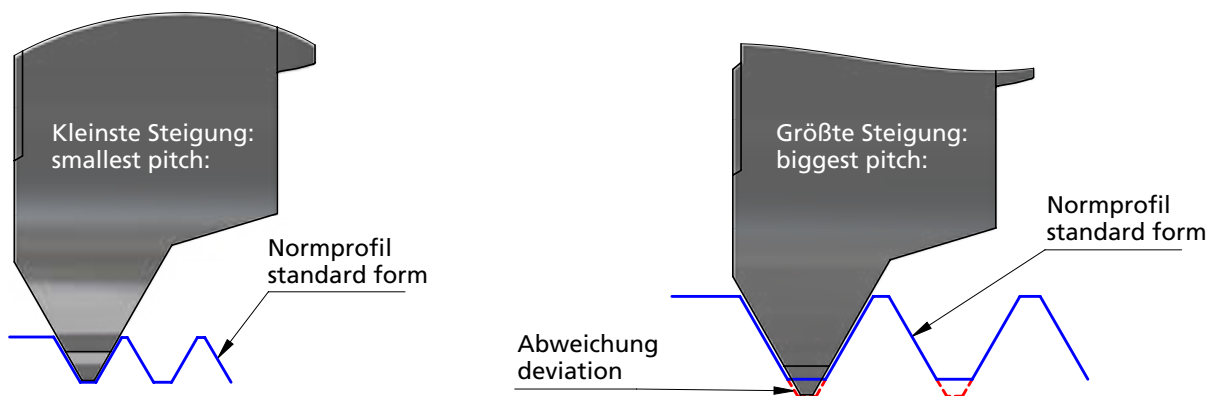

MINIMILL

Nut-, Formzirkular- und Trennfräsen

groove milling by circular interpolation, groove and slot milling

Technische Hinweise

Grundsätzliche Informationen zum Gewindefräsen

Technical instructions, basic informations about thread milling

Auswahlhilfe Mehrbereichswerkzeuge

In der nachfolgenden Tabelle sind alle DÜMMEL - Mehrbereichswerkzeuge aufgeführt. Anhand dieser Tabelle können Sie den jeweiligen Einsatzbereich entnehmen (blau= optimale Kontur, grau= mögliche Konturen):

Selection guide multi-purpose-tools

In the following chart are all DÜMMEL - multi-purpose-tools listed. This chart shows the possible area of application (blue= optimal profile; grey= possible profiles):

ab Gewindegröße / starting with thread-size	Steigung (mm)/ pitch (mm)															
	1	1,25	1,5	1,75	2	2,5	2,75	3	3,5	3,75	4	4,5	5	5,5	6	
Z610.0510.01	M12	M13	M14	M14												
Z610.0720.01	M13	M13	M14	M14	M15											
Z610.0815.01			M15	M15	M16	M18	M18									
Z610.2530.01					M16	M18	M18	M19								
Z12.0510.01	M14	M15	M15	M16												
Z12.0720.01	M14	M15	M15	M16	M16											
Z12.0815.01			M15	M16	M16	M17	M17									
Z12.2530.01					M16	M17	M17	M18								
Z614.0510.01	M15	M15	M16	M16												
Z614.0720.01	M15	M15	M16	M17	M17											
Z614.0815.01			M17	M17	M18	M20	M21									
Z614.2530.01					M18	M20	M21	M21								
Z16.0510.01	M18	M19	M20	M20												
Z16.0720.01	M18	M19	M20	M20	M21											
Z16.0815.01			M20	M20	M21	M21	M22									
Z16.2530.01					M21	M21	M22	M22								
Z18.0510.01	M21	M21	M22	M22												
Z18.0720.01/Z618.0720.01	M21	M21	M22	M22	M23											
Z18.0815.01			M22	M22	M23	M24	M24									
Z18.1325.01					M23	M24	M24	M24								
Z18.2535.01/Z618.2545.01					M23	M24	M24	M24	M25							
Z18.1020.01					M23	M24	M24	M24	M25	M26						
Z18.1630.01						M24	M24	M24	M25	M26	M26	M27	M28			
Z18.1835.01								M24	M25	M26	M26	M27	M28	M28		
Z22.0720.01/Z622.0720.01	M25	M25	M25	M26	M27											
Z22.0815.01			M26	M26	M27	M28	M28									
Z22.1020.01					M27	M28	M28	M29	M30	M30						
Z22.2545.01/Z622.2545.01					M27	M28	M28	M29	M30	M30	M30	M31				
Z22.1630.01						M28	M28	M29	M30	M30	M30	M31	M32			
Z22.2140.01									M30	M30	M30	M31	M32	M33	M34	
Z22.2445.01									M30	M30	M30	M31	M32	M33	M34	
Z28.0720.01	M31	M31	M32	M32	M33											
Z28.1525.01/Z628.1525.01			M32	M32	M33	M34										
Z28.3050.01/Z628.3050.01						M34	M35	M35	M36	M36	M37	M38	M39			
Z28.5060.01											M37	M38	M39	M39	M40	

MINIMILL

Nut-, Formzirkular- und
Trennfräsen

groove milling by
circular interpolation,
groove and slot milling

Technische Hinweise

Grundsätzliche Informationen zum Gewindefräsen

Technical instructions,
basic informations about thread milling

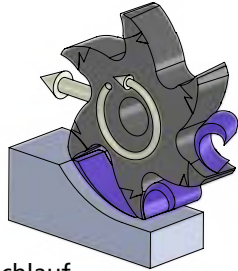

Gleichlauf
down-cut

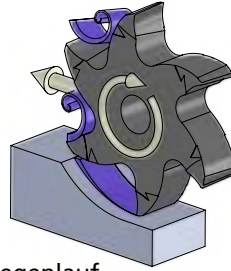

Gegenlauf
up-cut

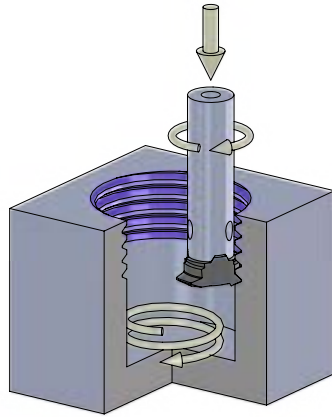

Rechtsgewinde (Gegenlauf)
Linksgewinde (Gleichlauf)*
RH-thread (up-cut)
LH-thread (down-cut)*

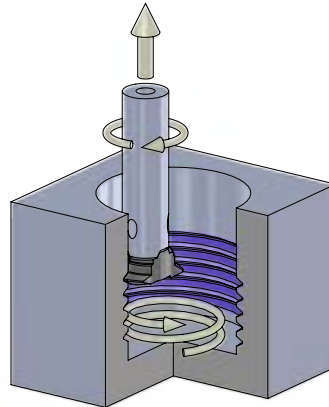

Rechtsgewinde (Gleichlauf)
Linksgewinde (Gegenlauf)*
RH-thread (down-cut)
LH-thread (up-cut)*

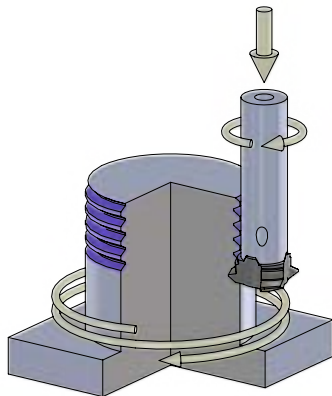

Rechtsgewinde (Gleichlauf)
Linksgewinde (Gegenlauf)*
RH-thread (down-cut)
LH-thread (up-cut)*

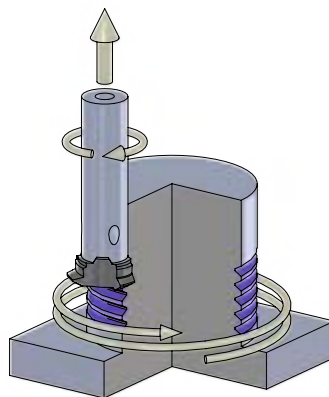

Rechtsgewinde (Gegenlauf)
Linksgewinde (Gleichlauf)*
RH-thread (up-cut)
LH-thread (down-cut)*

*Spiralbewegung axial gespiegelt
*spiral movement axially mirrored



MINIMILL

Nut-, Formzirkular- und Trennfräsen

groove milling by circular interpolation, groove and slot milling

MINIMILL XL

Nut- und Trennfräsen

groove and slot milling

Technische Hinweise

Hartmetallsorten und Beschichtungen

Technical instructions, carbide grades and coatings

K10F

Universell einsetzbares Feinkornhartmetall mit guter Verschleißfestigkeit. Unbeschichtet geeignet für Anwendungen mit niedrigen und mittleren Schnittgeschwindigkeiten, sowie die Bearbeitung von NE-Metallen.

All purpose micrograin carbide with good abrasion resistance. Uncoated for applications with low or medium cutting speeds and machining of non-ferrous materials.

P04C

Optimierte, sehr universell einsetzbare TIALN-Beschichtung mit hoher Temperaturbeständigkeit bei hoher Härte. Sehr gut geeignet auch für NE-Metalle.

Optimized TIALN coating - very universal with a high resistance to high temperature and hardness. Very suitable also for non-ferrous metals.

AL41F

Sehr universell einsetzbare TIALN-Beschichtung mit hoher Temperaturbeständigkeit bei hoher Härte. Sehr gut geeignet auch für NE-Metalle.

TIALN coating - very universal with a high resistance to high temperature and hardness. Very suitable also for non-ferrous metals.

CN45F

Universell einsetzbare PVD-TIN-Beschichtung. Diese Allround-Sorte ist für niedrige und mittlere Schnittgeschwindigkeiten mit Einschränkung bei NE-Metallen.

PVD-TIN coating - all purpose, all around grade is suitable for low and medium cutting speed with restrictions on non-ferrous materials.

P18C

Universell einsetzbare Hochleistungsschicht mit hoher Oxidationsbeständigkeit, Verschleißfestigkeit und Warmhärte.

Very universal high performance coating with high oxidation resistance, wear resistance and hot hardness resistance.

P07C

Beschichtung für die Bearbeitung von Titan, Edelstahl und Molybdän.

Coating to machine titanium, stainless steel and molybdenum.

MINIMILL

Nut-, Formzirkular- und
Trennfräsen

groove milling by
circular interpolation,
groove and slot milling

MINIMILL XL

Nut- und Trennfräsen

groove and slot milling

Technische Hinweise

Hartmetallsorten und Beschichtungen

Technical instructions,
carbide grades and coatings

XC2A

Beschichtung mit einer exzellenten Warmhärte, Oxidationsbeständigkeit und thermischen Isolationsfähigkeit. Ideal für Hartzerspanung >60HRC

Coating with excellent hot hardness, high oxidation resistance and thermal insulation capacity. Ideal for hard machining >60 HRC.

P03C

Beschichtung für die Bearbeitung von schwer zerspanbaren Materialien. Sehr gut auch für die Trockenbearbeitung geeignet.

Coating for materials which are difficult to machine. Perfect to use for dry machining.

PD2F

Beschichtung für den universellen Einsatz bei niedrigen und mittleren Schnittgeschwindigkeiten.

Coating for universal use with medium and low speed.

NEME

Beschichtung für die Bearbeitung von Aluminium, Al-Legierungen, NE-Metallen und Kompositwerkstoffen.

Coating for machining aluminium, Al alloys, non-ferrous metals and composite materials.



MINIMILL

Nut-, Formzirkular- und Trennfräsen

groove milling by circular interpolation, groove and slot milling

MINIMILL XL

Nut- und Trennfräsen

groove and slot milling

Technische Hinweise

Ermittlung der Schnittdaten

Technical instructions, evaluation of the cutting data

$$n = \frac{V_c * 1000}{d * \pi} \quad V_{eff} = f_z * z * n \quad f_z = h_m * \sqrt{\frac{d}{a_e}}$$

Fräsen Außenkontur
milling external

$$V_{prog} = \frac{V_{eff} * (D + d)}{D}$$

$$V_{eff} = \frac{D * V_{prog}}{(D + d)}$$

Fräsen Innenkontur
milling internal

$$V_{prog} = \frac{V_{eff} * (D - d)}{D}$$

$$V_{eff} = \frac{D * V_{prog}}{(D - d)}$$

Formel-Zeichen
formula characters

Bezeichnungen
specifications

Einheit
unit

a_e

Spantiefe radial
radial depth of cut

mm

d

Fräserdurchmesser
milling diameter

mm

D

Konturdurchmesser
contour diameter

mm

f_z

Vorschub pro Zahn
feed per tooth

mm

h_m

mittlere Spandicke
medium thickness of chip

mm

h_{max}

maximale Spandicke
maximum thickness of chip

mm

n

Spindeldrehzahl
revolutions

U / min

R

Radius Fräser
radius of cutter

mm

Nach Möglichkeit immer im Kreisbogen eintauchen.

Always plunge in a circular arc where possible.

MINIMILL

Nut-, Formzirkular- und
Trennfräsen

groove milling by
circular interpolation,
groove and slot milling

MINIMILL XL

Nut- und Trennfräsen

groove and slot milling

Technische Hinweise

Ermittlung der Schnittdaten

Technical instructions,
evaluation of the cutting data

$$n = \frac{V_c * 1000}{d * \pi}$$

$$V_f = f_z * z * n$$

$$f_z = h_m * \sqrt{\frac{d}{a_e}}$$

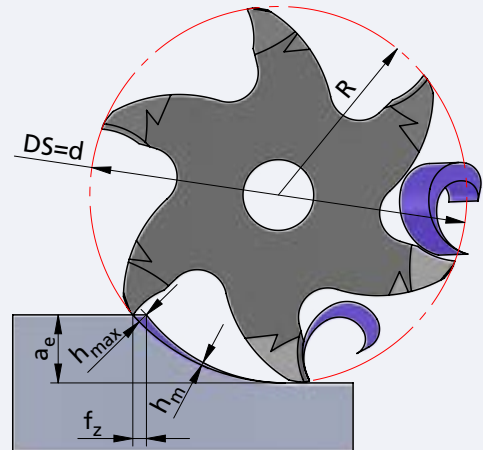

Formel-Zeichen
formula characters

Bezeichnungen
specifications

Einheit
unit

V_{eff}

effektive Vorschubgeschwindigkeit
(auf / an der Kontur)
feed rate of tool tip

mm / min

V_{prog}

programmierte Vorschubgeschwindigkeit
feed rate of tool center

mm / min

V_c

Schnittgeschwindigkeit
cutting speeds

m / min

V_f

Vorschubgeschwindigkeit
feed rate of tool center

mm / min

z

Schneidenzahl Fräser
number of cutting edges

Stk.
pcs.

MINIMILL

Nut-, Formzirkular- und Trennfräsen

groove milling by circular interpolation, groove and slot milling

MINIMILL XL

Nut- und Trennfräsen

groove and slot milling

Technische Hinweise

Schnittdatenempfehlung: metrisch

Technical instructions, speed and feed recommendation: metric

Schnittgeschwindigkeit: V_c (m/min)
Vorschub pro Zahn: fz (mm)

cutting speed: V_c (m/min)
feed per tooth: fz (mm)

Werkstoffgruppe material group		Zusammensetzung composition		(Zug-)Festigkeit tensile strength
ISO	Beschreibung / description	Gefüge / structure	Wärmebehandlung / heat treatment	Psi / N/mm ² (Rm) / HB / HRC
P	Unlegierter Stahl unalloyed steel	ca.Japp. 0,15 % C	geglüht / annealed	61000 Psi / 420 N/mm ² / 125 HB
		ca.Japp. 0,45 % C	geglüht / annealed	93000 Psi / 640 N/mm ² / 190 HB
			vergütet / tempered	122000 Psi / 840 N/mm ² / 250 HB
		ca.Japp. 0,75 % C	geglüht / annealed	132000 Psi / 910 N/mm ² / 270 HB
	Niedriglegierter Stahl low alloyed steel		vergütet / tempered	146500 Psi / 1010 N/mm ² / 300 HB
			geglüht / annealed	88500 Psi / 610 N/mm ² / 180 HB
			vergütet / tempered	135000 Psi / 930 N/mm ² / 275 HB
			vergütet / tempered	146500 Psi / 1010 N/mm ² / 300 HB
			vergütet / tempered	174000 Psi / 1200 N/mm ² / 375 HB
			geglüht / annealed	99000 Psi / 680 N/mm ² / 200 HB
Hochlegierter (Werkzeug)-Stahl highly alloyed steel			gehärtet & angelassen / hardened & tempered	160000 Psi / 1100 N/mm ² / 300 HB
			gehärtet & angelassen / hardened & tempered	189000 Psi / 1300 N/mm ² / 400 HB
Nichtrostender Stahl stainless steel		ferritisch, martensitisch / ferritic, martensitic	geglüht / annealed	99000 Psi / 680 N/mm ² / 200 HB
		martensitisch / martensitic	vergütet / tempered	117500 Psi / 810 N/mm ² / 250 HB
M	Nichtrostender Stahl stainless steel	austenitisch / austenitic	abgeschreckt / quenched	88500 Psi / 610 N/mm ² / 200 HB
		austenitisch / austenitic	vergütet / tempered	300 HB
		austenitisch, ferritisch / ferritic, martensitic (Duplex)		113000 Psi / 780 N/mm ² / 230 HB
K	Grauguss cast iron	perlitisch, ferritisch / pearlitic, ferritic		51000 Psi / 350 N/mm ² / 180 HB
		perlitisch (martensitisch) / pearlitic (martensitic)		72500 Psi / 500 N/mm ² / 260 HB
	Gusseisen mit Kugelgraphit cast iron with nodular graphite	ferritisch / ferritic		72500 Psi / 500 N/mm ² / 160 HB
		perlitisch / pearlitic		122500 Psi / 845 N/mm ² / 250 HB
		ferritisch / ferritic		63800 Psi / 440 N/mm ² / 130 HB
Temperguss malleable iron		perlitisch / pearlitic		113000 Psi / 780 N/mm ² / 230 HB
N	Aluminium - Knetlegierungen wrought aluminum alloys	nicht aushärtbar / uncurable		60 HB
		aushärtbar / curable	ausgehärtet / cured	49000 Psi / 340 N/mm ² / 100 HB
		≤ 12% Si, nicht aushärtbar / uncurable		36250 Psi / 250 N/mm ² / 75 HB
	Aluminium - Gusslegierungen cast aluminum alloys	≤ 12% Si, aushärtbar / curable	ausgehärtet / cured	43500 Psi / 300 N/mm ² / 90 HB
		> 12% Si, nicht aushärtbar / uncurable		63800 Psi / 440 N/mm ² / 130 HB
Kupfer und Kupferlegierungen (Bronze / Messing) copper and copper alloys (bronze / brass)	PB > 1 %, Automatenlegierungen / free cutting alloys		54500 Psi / 375 N/mm ² / 110 HB	
	CuZn, CuSnZn		43500 Psi / 300 N/mm ² / 90 HB	
	CuSn, bleifrei & Elektrolytisch / lead free & electrolytic		49000 Psi / 340 N/mm ² / 100 HB	
Magnesium &-Legierungen / Mg-alloys	Magnesium und -Legierungen / and -alloys		70 HB	
S	Warmfeste Legierungen heat-resistant alloys	Fe-Basis / Fe base	geglüht / annealed	99000 Psi / 680 N/mm ² / 200 HB
			ausgehärtet / cured	137750 Psi / 950 N/mm ² / 280 HB
		Ni- oder Co-Basis / Ni- or Co-Base	geglüht / annealed	122000 Psi / 840 N/mm ² / 250 HB
			ausgehärtet / cured	171000 Psi / 1180 N/mm ² / 350 HB
			gegossen / cast	156600 Psi / 1080 N/mm ² / 320 HB
	Titanlegierungen titanium alloys	Reintitan / pure titanium		58000 Psi / 400 N/mm ²
		Alpha- + Beta-Legierungen / -alloys	ausgehärtet / cured	152250 Psi / 1050 N/mm ²
	Beta-Legierungen / -alloys		203000 Psi / 1400 N/mm ² / 410 HB	
H	Gehärteter Stahl hardened steel		gehärtet & angelassen / hardened & tempered	46-55 HRC
			gehärtet & angelassen / hardened & tempered	56-60 HRC
			gehärtet & angelassen / hardened & tempered	61-65 HRC
	Hartguss / chilled cast iron		gehärtet & angelassen / hardened & tempered	66-70 HRC
Gehärtetes Guss / hardened cast iron		gegossen / cast	400 HB	
		gehärtet & angelassen / hardened & tempered	55 HRC	
O	Nichtmetallische Werkstoffe non-metallic materials	Kunststoffe, duroplastisch / plastics, duroplastic		≤ 21750 Psi / ≤ 150 N/mm ²
		Kunststoffe, thermoplastisch / plastics, thermoplastic		≤ 14500 Psi / ≤ 100 N/mm ²
		aramidfaserverstärkt / aramid fiber reinforced		≤ 145000 Psi / ≤ 1000 N/mm ²
		glas/kohlefaserverstärkt / glas/carbon fiber reinforced		≤ 145000 Psi / ≤ 1000 N/mm ²
		Graphit / graphite		

Richtige Schnittgeschwindigkeit ist in Abhängigkeit von Dimension und Anwendungssituation zu wählen.
The correct cutting speed must be selected depending on the dimension and application situation.

20 (10 - 50) bevorzugte Wahl / best choice
20 (10 - 50) bedingt möglich / conditionally possible

20 (10 - 50)
empfohlener Startwert (bevorzugter Einsatzbereich)
recommended starting value (preferred application area)

MINIMILL

Nut-, Formzirkular- und Trennfräsen

groove milling by circular interpolation, groove and slot milling

MINIMILL XL

Nut- und Trennfräsen

groove and slot milling

Technische Hinweise

Schnittdatenempfehlung:

Technical instructions, speed and feed recommendation: imperial

cutting speed (SFM):
feed per tooth:

V_C (feet/min)
fz (inch)



Werkstoffgruppe material group		Zusammensetzung composition		(Zug-)Festigkeit tensile strength	
ISO	Beschreibung / description	Gefüge / structure	Wärmebehandlung / heat treatment	Psi / N/mm ² (Rm) / HB / HRC	
P	Unlegierter Stahl unalloyed steel	ca.Japp. 0,15 % C	geglüht / annealed	61000 Psi / 420 N/mm ² / 125 HB	
		ca.Japp. 0,45 % C	geglüht / annealed	93000 Psi / 640 N/mm ² / 190 HB	
			vergütet / tempered	122000 Psi / 840 N/mm ² / 250 HB	
		ca.Japp. 0,75 % C	geglüht / annealed	132000 Psi / 910 N/mm ² / 270 HB	
	Niedriglegierter Stahl low alloyed steel			vergütet / tempered	146500 Psi / 1010 N/mm ² / 300 HB
				geglüht / annealed	88500 Psi / 610 N/mm ² / 180 HB
				vergütet / tempered	135000 Psi / 930 N/mm ² / 275 HB
				vergütet / tempered	146500 Psi / 1010 N/mm ² / 300 HB
				vergütet / tempered	174000 Psi / 1200 N/mm ² / 375 HB
				geglüht / annealed	99000 Psi / 680 N/mm ² / 200 HB
Hochlegierter (Werkzeug-)Stahl highly alloyed steel			gehärtet & angelassen / hardened & tempered	160000 Psi / 1100 N/mm ² / 300 HB	
			gehärtet & angelassen / hardened & tempered	189000 Psi / 1300 N/mm ² / 400 HB	
Nichtrostender Stahl stainless steel		ferritisch, martensitisch / ferritic, martensitic	geglüht / annealed	99000 Psi / 610 N/mm ² / 200 HB	
		martensitisch / martensitic	vergütet / tempered	117500 Psi / 810 N/mm ² / 250 HB	
M	Nichtrostender Stahl stainless steel	austenitisch / austenitic	abgeschreckt / quenched	88500 Psi / 610 N/mm ² / 200 HB	
		austenitisch / austenitic	vergütet / tempered	300 HB	
		austenitisch, ferritisch / ferritic, martensitic (Duplex)		113000 Psi / 780 N/mm ² / 230 HB	
K	Grauguss cast iron	perlitisch, ferritisch / pearlitic, ferritic		51000 Psi / 350 N/mm ² / 180 HB	
		perlitisch (martensitisch) / pearlitic (martensitic)		72500 Psi / 500 N/mm ² / 260 HB	
	Gusseisen mit Kugelgraphit cast iron with nodular graphite	ferritisch / ferritic		72500 Psi / 500 N/mm ² / 160 HB	
		perlitisch / pearlitic		122500 Psi / 845 N/mm ² / 250 HB	
	Temperguss malleable iron	ferritisch / ferritic		63800 Psi / 440 N/mm ² / 130 HB	
perlitisch / pearlitic			113000 Psi / 780 N/mm ² / 230 HB		
N	Aluminium - Knetlegierungen wrought aluminum alloys	nicht aushärtbar / uncurable		60 HB	
		aushärtbar / curable	ausgehärtet / cured	49000 Psi / 340 N/mm ² / 100 HB	
	Aluminium - Gusslegierungen cast aluminum alloys	≤ 12% Si, nicht aushärtbar / uncurable		36250 Psi / 250 N/mm ² / 75 HB	
		≤ 12% Si, aushärtbar / curable	ausgehärtet / cured	43500 Psi / 300 N/mm ² / 90 HB	
		> 12% Si, nicht aushärtbar / uncurable		63800 Psi / 440 N/mm ² / 130 HB	
	Kupfer und Kupferlegierungen (Bronze / Messing) copper and copper alloys (bronze / brass)	PB > 1 %, Automatenlegierungen / free cutting alloys		54500 Psi / 375 N/mm ² / 110 HB	
CuZn, CuSnZn			43500 Psi / 300 N/mm ² / 90 HB		
Magnesium - & Legierungen / Mg-alloys	Magnesium und -Legierungen / and -alloys			49000 Psi / 340 N/mm ² / 100 HB	
				70 HB	
S	Warmfeste Legierungen heat-resistant alloys	Fe-Basis / Fe base	geglüht / annealed	99000 Psi / 680 N/mm ² / 200 HB	
			ausgehärtet / cured	137750 Psi / 950 N/mm ² / 280 HB	
		Ni- oder Co-Basis / Ni- or Co-Base	geglüht / annealed	122000 Psi / 840 N/mm ² / 250 HB	
			ausgehärtet / cured	171000 Psi / 1180 N/mm ² / 350 HB	
			gegossen / cast	156600 Psi / 1080 N/mm ² / 320 HB	
	Titanlegierungen titanium alloys	Reintitan / pure titanium		58000 Psi / 400 N/mm ²	
		Alpha- + Beta-Legierungen / -alloys	ausgehärtet / cured	152250 Psi / 1050 N/mm ²	
H	Gehärteter Stahl hardened steel		gehärtet & angelassen / hardened & tempered	46-55 HRC	
			gehärtet & angelassen / hardened & tempered	56-60 HRC	
			gehärtet & angelassen / hardened & tempered	61-65 HRC	
			gehärtet & angelassen / hardened & tempered	66-70 HRC	
	Hartguss / chilled cast iron		gegossen / cast	400 HB	
	Gehärtetes Guss / hardened cast iron		gehärtet & angelassen / hardened & tempered	55 HRC	
O	Nichtmetallische Werkstoffe non-metallic materials	Kunststoffe, duroplastisch / plastics, duroplastic		≤ 21750 Psi / ≤ 150 N/mm ²	
		Kunststoffe, thermoplastisch / plastics, thermoplastic		≤ 14500 Psi / ≤ 100 N/mm ²	
		aramidfaserverstärkt / aramid fiber reinforced		≤ 145000 Psi / ≤ 1000 N/mm ²	
		glas/kohlefaserverstärkt / glas/carbon fiber reinforced		≤ 145000 Psi / ≤ 1000 N/mm ²	
		Graphit / graphite			

The correct cutting speed must be selected depending on the dimension and application situation.

20 (10 - 50) best choice
20 (10 - 50) conditionally possible

20 (10 - 50)
recommended starting value (preferred application area)

MINIMILL

Nut-, Formzirkular- und Trennfräsen

groove milling by circular interpolation, groove and slot milling

MINIMILL XL

Nut- und Trennfräsen

groove and slot milling

Technische Hinweise

Schnittdatenempfehlung:

Technical instructions, speed and feed recommendation: imperial

cutting speed (SFM):
feed per tooth:

V_C (feet/min)
fz (inch)



beispielhafte Werkstoffe exemplary materials				V _C Start (min. - max.)		fz Start (min. - max.)		
AISI	DIN-Code	AISI	DIN-Code	P04C / AL41F [SFM]	[SFM]	Bohrungen / holes [inch]	Gewinde / thread [inch]	Trennen / parting off [inch]
1015	C15	1015	Ck 15	390 (260 - 660)		0,0012 - 0,0039	0,0020 - 0,0079	0,0006 - 0,0020
1045	C45E	12L13	9 SMnPb 28	360 (230 - 620)		0,0012 - 0,0039	0,0020 - 0,0079	0,0006 - 0,0020
1045	C45E	1055	C 55	300 (200 - 490)		0,0012 - 0,0039	0,0020 - 0,0079	0,0006 - 0,0020
1060	C60R	1055	C 55	300 (200 - 490)		0,0012 - 0,0031	0,0020 - 0,0071	0,0006 - 0,0016
1060	C60R	1146	45 S 20	230 (160 - 390)		0,0012 - 0,0031	0,0020 - 0,0071	0,0006 - 0,0016
5115	16 MnCr 5	4820	17 CrNiMo6	300 (200 - 490)		0,0012 - 0,0039	0,0020 - 0,0079	0,0006 - 0,0020
5115	16 MnCr 5	4820	17 CrNiMo6	230 (160 - 390)		0,0012 - 0,0031	0,0020 - 0,0071	0,0006 - 0,0016
4140	42 CrMo 4	E52100	100Cr6	200 (130 - 360)		0,0008 - 0,0028	0,0020 - 0,0063	0,0006 - 0,0014
4140	42 CrMo 4	E52100	100Cr6	200 (130 - 330)		0,0012 - 0,0028	0,0020 - 0,0063	0,0006 - 0,0014
420	X20Cr13	420	X46Cr13	200 (130 - 330)		0,0012 - 0,0039	0,0020 - 0,0079	0,0006 - 0,0020
H11	X 38 CrMoV 5 1	420	X46Cr13	160 (100 - 260)		0,0008 - 0,0028	0,0020 - 0,0063	0,0006 - 0,0014
H11	X 38 CrMoV 5 1	420	X46Cr13	100 (70 - 200)		0,0008 - 0,0028	0,0020 - 0,0063	0,0006 - 0,0014
430/1	X 6 Cr 17	422	X36 CrMo 16	260 (160 - 430)		0,0012 - 0,0031	0,0020 - 0,0071	0,0006 - 0,0016
440B	X90CrMoV18	422	X36 CrMo 16	200 (130 - 360)		0,0008 - 0,0028	0,0020 - 0,0063	0,0006 - 0,0014
304	X 5 CrNi 18 10	316Ti	X2CrNiMo17-12-2	300 (200 - 490)		0,0008 - 0,0028	0,0020 - 0,0063	0,0006 - 0,0014
314	X15CrNiSi25-21	904L	X1NiCrMoCu25-20-5	200 (130 - 360)		0,0008 - 0,0028	0,0020 - 0,0063	0,0006 - 0,0014
318	X2CrNiMoN22-5-3	A790	X2CrNiMoCuWN25-7-4	160 (100 - 300)		0,0008 - 0,0028	0,0020 - 0,0063	0,0006 - 0,0014
No 20B	GG-10	No 35B	GG-25	360 (230 - 620)		0,0012 - 0,0039	0,0020 - 0,0079	0,0006 - 0,0020
No 45B	GG-30	-	GG-45	260 (160 - 460)		0,0012 - 0,0039	0,0020 - 0,0079	0,0006 - 0,0020
60-40-18	GGG-40	80-55-06	GGG-60	230 (160 - 390)		0,0012 - 0,0039	0,0020 - 0,0079	0,0006 - 0,0020
100-70-03	GGG-70	120-90-02	GGG-80	200 (130 - 330)		0,0012 - 0,0039	0,0020 - 0,0079	0,0006 - 0,0020
-	GTW-35-04	-	GTW-45	360 (230 - 620)		0,0012 - 0,0039	0,0020 - 0,0079	0,0006 - 0,0020
A220-70003	GTS-65-02	A220-80002	GTS-70-02	300 (200 - 520)		0,0012 - 0,0039	0,0020 - 0,0079	0,0006 - 0,0020
A91060	Al99,5	5005A	AlMg 1	750 (490 - 1280)		0,0016 - 0,0059	0,0024 - 0,0098	0,0008 - 0,0030
2024	AlCuMg2	6082	AlMgSi1	720 (460 - 1210)		0,0016 - 0,0059	0,0024 - 0,0098	0,0008 - 0,0030
A04130	G-AlSi12	-	G-AlSi9Cu3	620 (390 - 1050)		0,0016 - 0,0059	0,0024 - 0,0098	0,0008 - 0,0030
355.1	G-AlSi5Cu1Mg	-	G-AlSi9Mg	520 (360 - 890)		0,0016 - 0,0059	0,0024 - 0,0098	0,0008 - 0,0030
-	G-AlSi17Cu4Mg (Silafont-90)	-	G-AlSi18CuNiMg (Silafont-92)	300 (200 - 520)		0,0016 - 0,0059	0,0024 - 0,0098	0,0008 - 0,0030
C37700	CuZn39Pb2 (Ms58)	C38500	CuZn44Pb2	560 (360 - 920)		0,0016 - 0,0059	0,0024 - 0,0098	0,0008 - 0,0030
C34000	CuZn15	-	CuZn28Sn1As	460 (300 - 790)		0,0016 - 0,0059	0,0024 - 0,0098	0,0008 - 0,0030
C11000	E-Cu57	-	CuZn40Fe	390 (260 - 690)		0,0016 - 0,0059	0,0024 - 0,0098	0,0008 - 0,0030
AZ61A	MgAl6Zn	AZ31B	MgAl3Zn	560 (360 - 920)		0,0016 - 0,0059	0,0024 - 0,0098	0,0008 - 0,0030
330	X12NiCrSi 36-16	-	G-X40NiCrSi38-18	200 (130 - 330)		0,0016 - 0,0059	0,0024 - 0,0098	0,0008 - 0,0030
A286	X6NiCrTiMoVB25-15-2	B163	X10NiCrAlTi32-20	130 (100 - 230)		0,0016 - 0,0059	0,0024 - 0,0098	0,0008 - 0,0030
-	NiCr20TiAl (Nimonic 80A)	SB443	NiCr22Mo9Nb (Inconel 625)	200 (130 - 330)		0,0016 - 0,0059	0,0024 - 0,0098	0,0008 - 0,0030
-	NiCr19Nb5Mo3 (Inconel 718)	-	NiFe25Cr20NbTi	160 (100 - 260)		0,0016 - 0,0059	0,0024 - 0,0098	0,0008 - 0,0030
-	CoCr20W15Ni	A 128 75	G-X120Mn12	100 (70 - 200)		0,0016 - 0,0059	0,0024 - 0,0098	0,0008 - 0,0030
R 50250	Ti99,8	R 50400	Ti99,7	200 (130 - 330)		0,0016 - 0,0059	0,0024 - 0,0098	0,0008 - 0,0030
R 56400	TiAl6V4	R 56260	Ti-6Al-2Sn-4Zr-6Mo	100 (70 - 200)		0,0016 - 0,0059	0,0024 - 0,0098	0,0008 - 0,0030
-	Ti-5Al-5V-5Mo-3Cr	R 56410	Ti-10V-2Fe-3Al	100 (70 - 160)		0,0016 - 0,0059	0,0024 - 0,0098	0,0008 - 0,0030
				160 (100 - 300)		0,0008 - 0,0024	0,0016 - 0,0055	0,0008 - 0,0015
				130 (100 - 230)		0,0008 - 0,0039	0,0020 - 0,0059	0,0006 - 0,0020
				590 (390 - 1020)		0,0016 - 0,0059	0,0024 - 0,0098	0,0008 - 0,0015
				560 (360 - 920)		0,0016 - 0,0059	0,0024 - 0,0098	0,0008 - 0,0015
				460 (300 - 750)		0,0016 - 0,0059	0,0024 - 0,0098	0,0008 - 0,0015
				330 (230 - 560)		0,0016 - 0,0059	0,0024 - 0,0098	0,0008 - 0,0015
				460 (300 - 750)		0,0002 - 0,0020	0,0024 - 0,0098	0,0001 - 0,0010



The correct cutting speed must be selected depending on the dimension and application situation.

20 (10 - 50) best choice
20 (10 - 50) conditionally possible

20 (10 - 50) recommended starting value (preferred application area)



duemmel.de

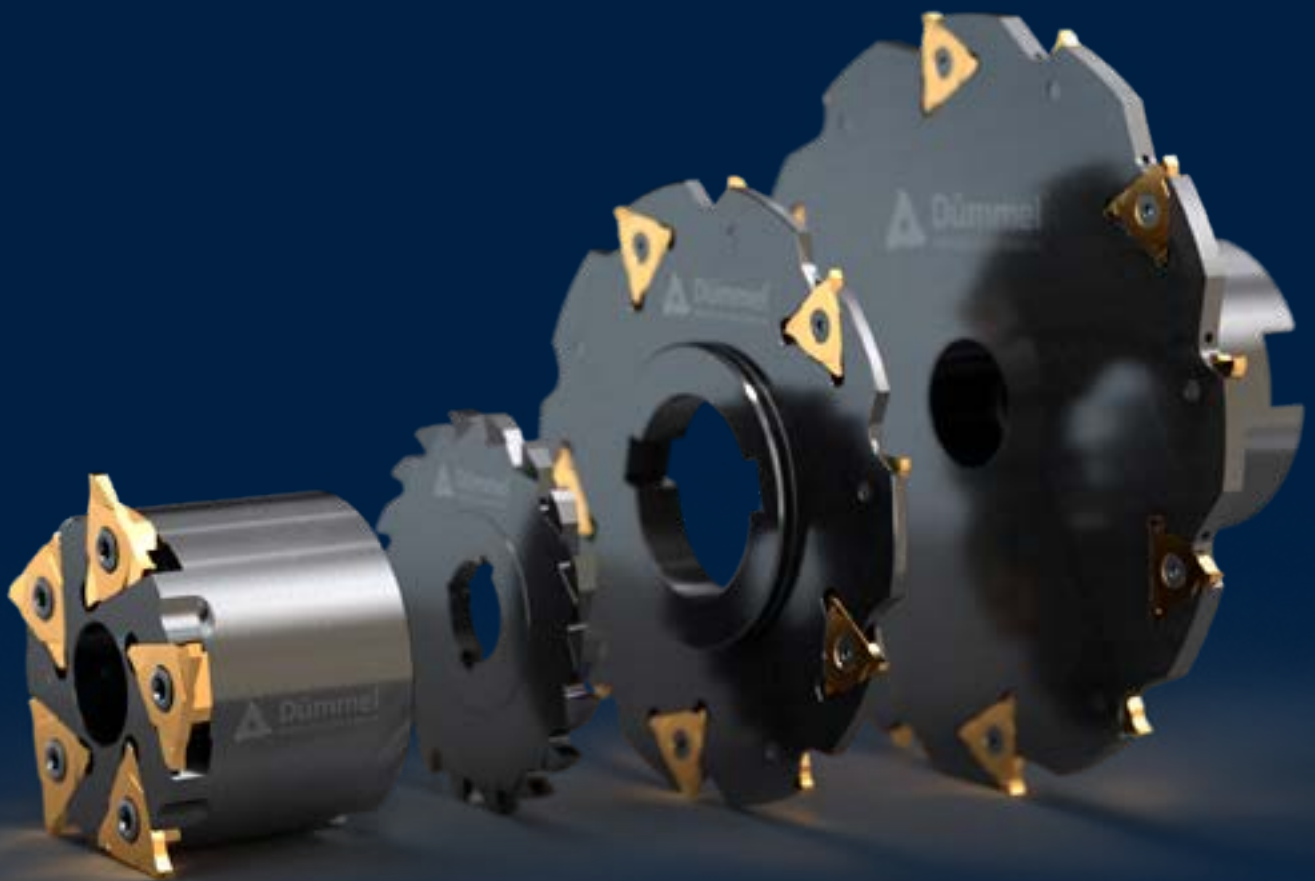

SYSTEM 500

$DS \geq \varnothing 44 \text{ mm}$

$D \text{ min.} \geq \varnothing 45 \text{ mm}$

$b \geq 1.41 \text{ mm}$

SYSTEM 500

Nut-, Formzirkular- und
Trennfräsen

groove milling by
circular interpolation,
groove and slot milling

Übersicht

summary

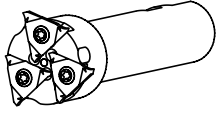

Allgemeine Beschreibung

general instructions

... 6

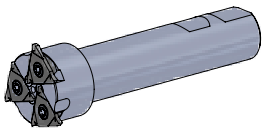

Messerköpfe

milling cutter type

Maße
dimensions
[mm]

Seite
page

Typ 500.44.3

Fräuserschaft

milling shank

D min. 45
t max. 4.0

... 7

Typ 510.0063.05-D

Messerkopf

milling cutter

D min. 64
t max. 5.0

... 8

Typ 510.0080.08-D

Messerkopf

milling cutter

D min. 81
t max. 5.0

... 9

Typ 581

Messerkopf

milling cutter

D min. 64
t max. 5.0

... 10

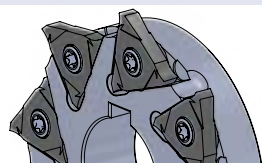

Fräswendeschneidplatten

indexable milling inserts

Maße
dimensions
[mm]

Seite
page

Typ 514

für Sicherungsringe DIN 471/472
für Typ 500 / Typ 510 / Typ 581

for circlips DIN 471/472
for type 500 / Typ 510 / Typ 581

... 11

Typ 514

für Sicherungsringe DIN 471/472,
mit Nutaußenkantenfasung
für Typ 500 / Typ 510 / Typ 581

for circlips DIN 471/472,
with chamfer
for type 500 / type 510 / type 581

... 12

Typ 514

metrisches ISO-Gewinde,
Teilprofil, innen
für Typ 500 / Typ 510 / Typ 581

metric ISO-thread,
partial profile, internal
for type 500 / type 510 / type 581

Steigung / pitch
P = 1.5 - 6.0

... 13

Typ 514

metrisches ISO-Gewinde,
Vollprofil, innen
für Typ 500 / Typ 510 / Typ 581

metric ISO-thread,
full profile, internal
for type 500 / type 510 / type 581

Steigung / pitch
P = 1.5 - 5.5

... 14

SYSTEM 500

Nut-, Formzirkular- und
Trennfräsen

groove milling by
circular interpolation,
groove and slot milling

Übersicht

summary

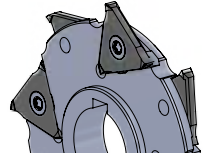
	Hochleistungsscheibenfräser mit Wendeschneidplatten Breite 6 / 8 / 10 mm	high performance disk-milling cutter with indexable inserts width 6 / 8 / 10 mm	Maße dimensions [mm]	Seite page
---	---	--	-------------------------------------	-----------------------

Typ 590... .6
Typ 590... .8
Typ 590... .10

Hochleistungsscheibenfräser
mit Bohrung und
Längsnut nach DIN 138

high performance
disk-milling cutter with bore
and longitudinal keyway
according DIN 138

b = 6
b = 8
b = 10

... 15

Typ 591... .6

Hochleistung Aufsteck-Scheibenfräser

high performance arbor mounted
disk-milling cutter

b = 6

... 16

	Fräswendeschneidplatten	indexable milling inserts	Maße dimensions [mm]	Seite page
--	--------------------------------	----------------------------------	-------------------------------------	-----------------------

Typ 514

Fräswendeschneidplatten:
für Hochleistungsscheibenfräser

indexable milling inserts:
for high performance
disk-milling cutter

Typ 590... .6 / Typ 591... .6
Typ 590... .8 / Typ 591... .8
Typ 590... .10 / Typ 591... .10

Typ 590... .6 / Typ 591... .6
Typ 590... .8 / Typ 591... .8
Typ 590... .10 / Typ 591... .10

b = 6
b = 8
b = 10

... 17



SYSTEM 500

Nut-, Formzirkular- und
Trennfräsen

groove milling by
circular interpolation,
groove and slot milling

Übersicht

summary

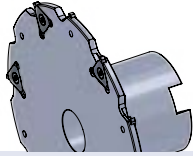

**Hochleistungstrennfräser
für Wendeschneidplatten
Breite 3 / 4 / 5 mm**

**high performance
slotting cutter
for indexable inserts
width 3 / 4 / 5 mm**

**Maße
dimensions
[mm]**

**Seite
page**

**Typ 590... .3
Typ 590... .4
Typ 590... .5**

Hochleistungstrennfräser
mit Bohrung und
Längsnut nach DIN 138

high performance
slotting cutter with bore
and longitudinal keyway
according DIN 138

b = 3
b = 4
b = 5

... 18

Typ 591... .3

Hochleistungs Aufsteck-Trennfräser
mit Bohrung und
Quernut nach DIN 138

high performance arbor mounted
slotting cutter with bore and cross
keyway according DIN 138

b = 3

... 19

Typ 591... .3-IK

Hochleistungs Aufsteck-Trennfräser
mit Bohrung und
Quernut nach DIN 138
und innerer Kühlmittelzufuhr

high performance arbor mounted
slotting cutter with bore and cross
keyway according to DIN 138
and internal coolant supply

b = 3

... 20

Typ 591... .4

Hochleistungs Aufsteck-Trennfräser
mit Bohrung und
Quernut nach DIN 138

high performance arbor mounted
slotting cutter with bore and cross
keyway according DIN 138

b = 4

... 21

Typ 591... .4-IK

Hochleistungs Aufsteck-Trennfräser
mit Bohrung und
Quernut nach DIN 138
und innerer Kühlmittelzufuhr

high performance arbor mounted
slotting cutter with bore and cross
keyway according to DIN 138
and internal coolant supply

b = 4

... 22

Typ 591... .5

Hochleistungs Aufsteck-Trennfräser
mit Bohrung und
Quernut nach DIN 138

high performance arbor mounted
slotting cutter with bore and cross
keyway according DIN 138

b = 5

... 23

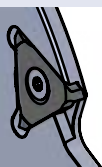

Fräswendeschneidplatten

indexable milling inserts

**Maße
dimensions
[mm]**

**Seite
page**

Typ 510

Fräswendeschneidplatten:
für Hochleistungs
(Aufsteck)-Trennfräser

indexable milling inserts:
for high performance
(arbor mounted) slotting cutter

Typ 590... .3 / Typ 591... .3 (-IK)
Typ 590... .4 / Typ 591... .4 (-IK)
Typ 590... .5 / Typ 591... .5

Typ 590... .3 / Typ 591... .3 (-IK)
Typ 590... .4 / Typ 591... .4 (-IK)
Typ 590... .5 / Typ 591... .5

b = 3
b = 4
b = 5

... 24

SYSTEM 500

Nut-, Formzirkular- und
Trennfräsen

groove milling by
circular interpolation,
groove and slot milling

Übersicht

summary

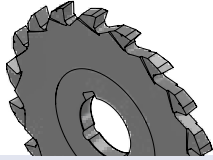

**Hochleistungsscheibenfräser
VHM
Breite 2 - 10 mm**

**high performance
disk-milling cutter
carbide
width 2 - 10 mm**

**Maße
dimensions
[mm]**

**Seite
page**

Typ 550.063.00

VHM - Hochleistungsscheibenfräser

carbide high performance
disk-milling cutter

b = 2 - 10

... **25**

Typ 550.063.20

VHM - Hochleistungsscheibenfräser,
mit Eckenradius

carbide high performance
disk-milling cutter,
with corner radius

b = 2 - 10

... **26**

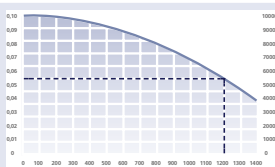

Technische Hinweise

Technical Instructions

**Seite
page**

Grundsätzliche Informationen
zum Gewindefräsen

basic informations about
thread milling

... **27**

Hartmetallsorten und
Beschichtungen

carbide grades and coatings

... **30**

Ermittlung der Schnittdaten

evaluation of the cutting data

... **32**

Schnittdatenempfehlung

speed and feed recommendation

... **34**

SYSTEM 500

Nut-, Formzirkular- und
Trennfräsen

groove milling by
circular interpolation,
groove and slot milling

Allgemeine Beschreibung

general instruction

Sehr scharf geschliffene dreischneidige Wendeschneidplatten
garantieren beste Ergebnisse auch bei hochfesten Materialien.

Extremely sharp grinded inserts with three-cutting edges
guarantees best results, even at high-strength materials.



SYSTEM 500

Nut-, Formzirkular- und Trennfräsen

groove milling by circular interpolation, groove and slot milling

Typ 500.44.3

Fräseschaft

D min. 45 mm
t max. 4.0

milling shank

D min. 45 mm
t max. 4.0

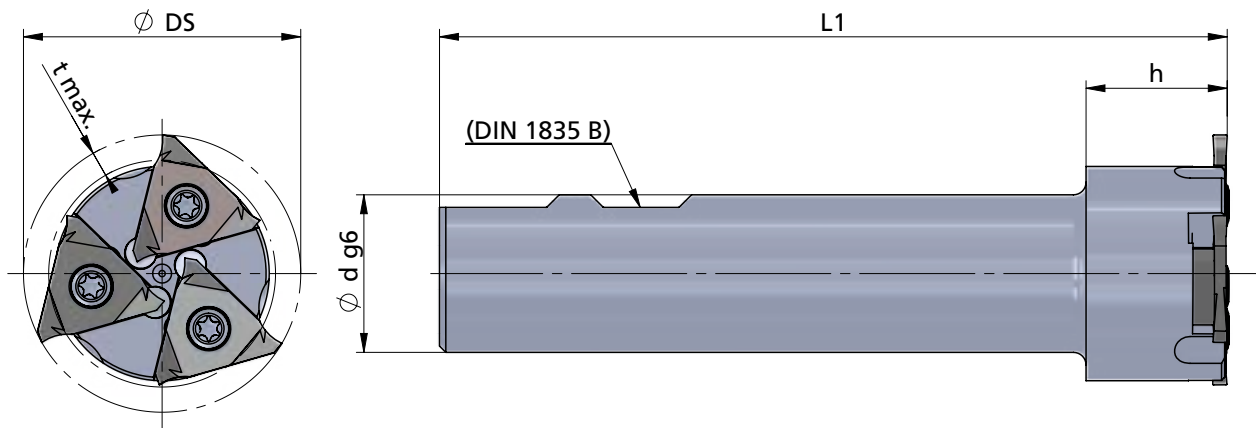

Beispielzeichnung
exemplary application

Abmessungen in mm

dimensions in mm



Bestellnummer part number	Ø DS	Ø d g6	t max.	L1	h	Schneidenzahl number of cutting edges	Spannschraube screw	Schraubenschlüssel wrench	Anzugs- drehmoment torque	für Schneidplatten for insert
500.44.3	44	25	4	125	22.4	3	A.SPS011	TR20-P	6.0 Nm	514....

Achtung:
Schneidplatten sind nicht im Lieferumfang
enthalten!

Bestellbeispiel:
500.44.3

Attention:
Inserts are not included in the scope of delivery!

order-example:
500.44.3

SYSTEM 500

Nut-, Formzirkular- und Trennfräsen

groove milling by circular interpolation, groove and slot milling

Typ 510.0063.05-D

Messerkopf

D min. 64 mm
t max. 5.0

milling cutter

D min. 64 mm
t max. 5.0

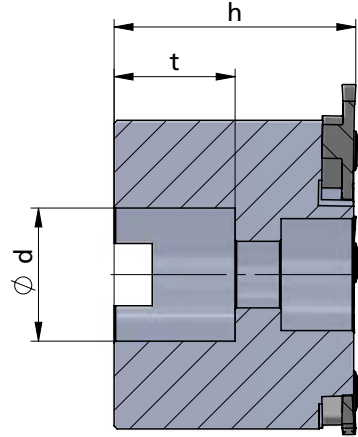
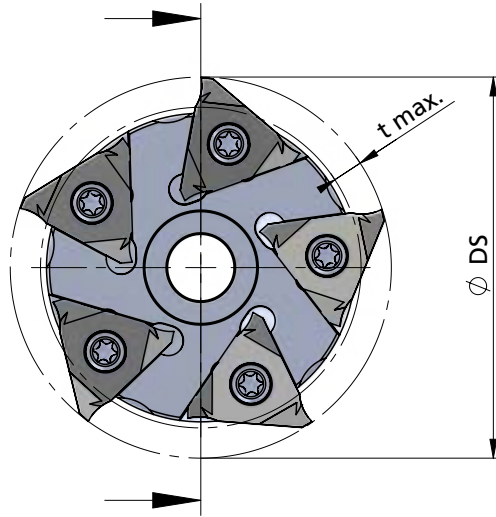

Beispielzeichnung
exemplary application

Abmessungen in mm

dimensions in mm

Bestellnummer part number	Ø DS	Ø d x t	t max.	h	Schneidenzahl number of cutting edges	Spannschraube screw	Schraubenschlüssel wrench	Anzugsdrehmoment torque	für Schneidplatten for insert
510.0063.05-D	63	Ø22 x 20	5	40	5	A.SPS011	TR20-P	6.0 Nm	514....

Achtung:
Schneidplatten sind nicht im Lieferumfang enthalten!

Attention:
Inserts are not included in the scope of delivery!

Bestellbeispiel:
510.0063.05-D

order-example:
510.0063.05-D

SYSTEM 500

Nut-, Formzirkular- und Trennfräsen

groove milling by circular interpolation, groove and slot milling

Typ 510.0080.08-D

Messerkopf

D min. 81 mm
t max. 5.0

milling cutter

D min. 81 mm
t max. 5.0

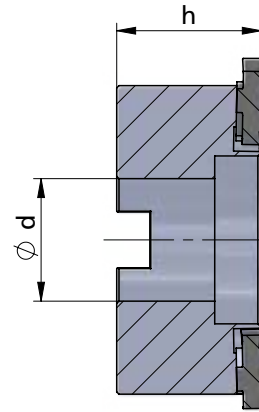
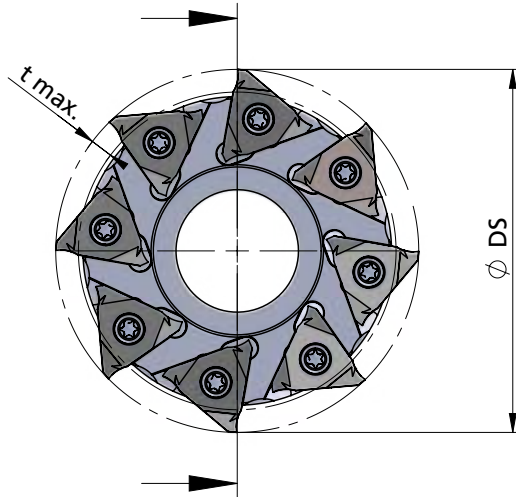

Beispielzeichnung
exemplary application

Abmessungen in mm

dimensions in mm



Bestellnummer part number	Ø DS	Ø d	t max.	h	Schneidenzahl number of cutting edges	Spannschraube screw	Schraubenschlüssel wrench	Anzugs- drehmoment torque	für Schneidplatten for insert
510.0080.08-D	80	27	5	32	8	A.SPS011	TR20-P	6.0 Nm	514....

Achtung:
Schneidplatten sind nicht im Lieferumfang
enthalten!

Bestellbeispiel:
510.0080.08-D

Attention:
Inserts are not included in the scope of delivery!

order-example:
510.0080.08-D

SYSTEM 500

Nut-, Formzirkular- und Trennfräsen

groove milling by circular interpolation, groove and slot milling

Typ 581

Messerkopf

milling cutter

D min. 64 mm
t max. 5.0

D min. 64 mm
t max. 5.0

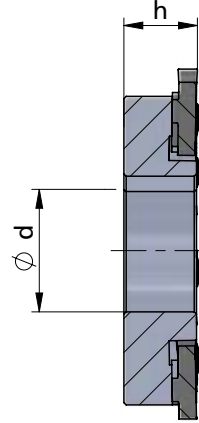
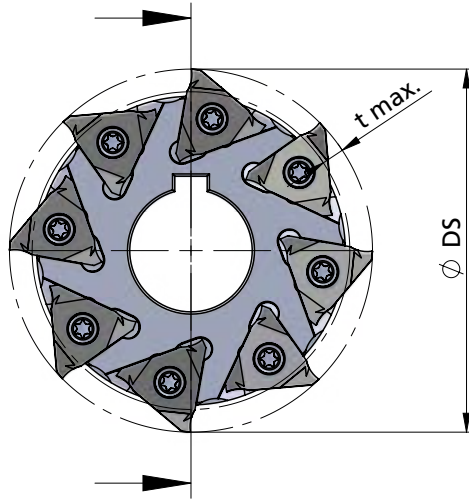

Beispielzeichnung
exemplary application

Abmessungen in mm

dimensions in mm

Bestellnummer part number	$\varnothing DS$	$\varnothing d$	t max.	h	Schneidenzahl number of cutting edges	Spannschraube screw	Schraubenschlüssel wrench	Anzugsdrehmoment torque	für Schneidplatten for insert
581.0063.05-D	63	22	5	14.2	5	A.SPS011	TR20-P	6.0 Nm	514....
581.0080.08-D	80	27	5	16.2	8				
581.0100.10-D	100	32	5	20.2	10				

Achtung:
Schneidplatten sind nicht im Lieferumfang enthalten!

Attention:
Inserts are not included in the scope of delivery!

Bestellbeispiel:
581.0063.05-D

order-example:
581.0063.05-D

SYSTEM 500

Nut-, Formzirkular- und Trennfräsen

groove milling by circular interpolation, groove and slot milling

Typ 514

Fräswendeschnidplatten, für Sicherungsringe DIN 471 / 472

indexable milling inserts, for circlip groove DIN 471 / 472

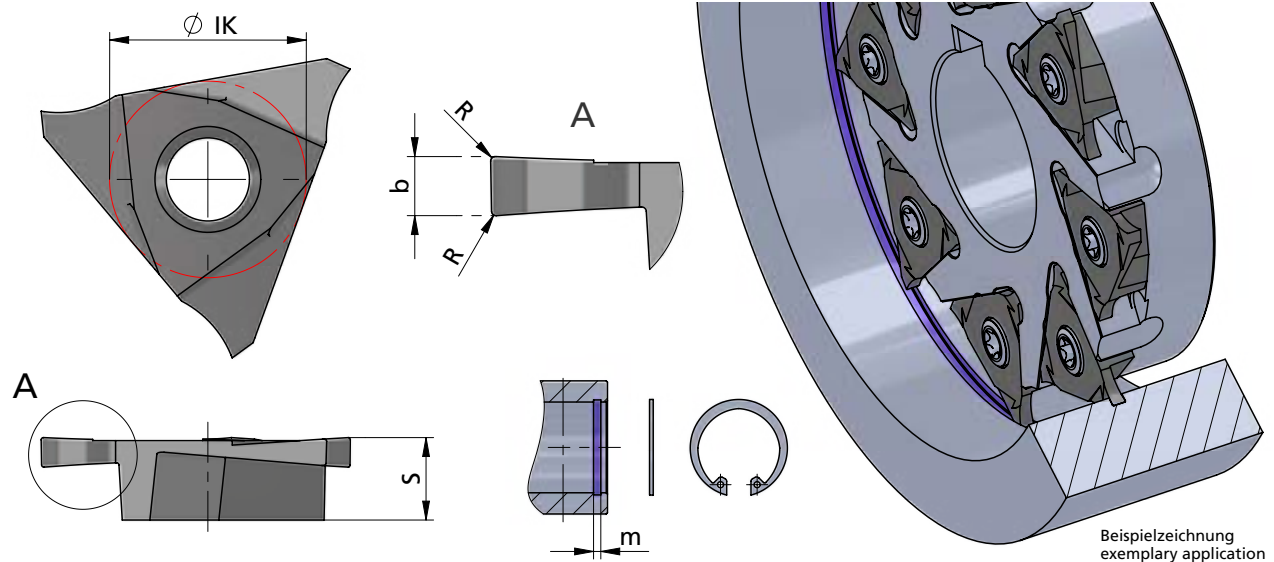

Abmessungen in mm

dimensions in mm



Bestellnummer part number	Nut-Maß m groove dim. m DIN 471 / DIN 472		s	b -0.02	R	Ø IK -0.03			für Fräseschaft / Messerkopf for milling shank / milling cutter	
							K10F	AL41F	CN45F	
514.0130.00	1.3		5.4	1.41	0.1	13	●	●	●	500... 510... 581...
514.0160.00	1.6		5.4	1.71	0.15	13	●	●	●	
514.0185.00	1.85		5.4	1.96	0.15	13	●	●	●	
514.0215.00	2.15		5.4	2.26	0.15	13	●	●	●	
514.0265.00	2.65		5.4	2.76	0.15	13	●	●	●	
514.0315.00	3.15		5.4	3.26	0.15	13	●	●	●	
514.0415.00	4.15		5.4	4.26	0.15	13	●	●	●	
514.0515.00	5.15		5.4	5.26	0.15	13	●	●	●	

Weitere HM Sorten können Sie in der Sortenübersicht im Kapitel "Technische Hinweise" und der Preisliste finden.

Bestellbeispiel für Sorte AL41F:
Rechts: 514.0130.00/AL41F
Links: L514.0130.00/AL41F (auf Anfrage)

More carbide grades you can find in the grades summary in the chapter "technical instructions" and in the price list.

order-example grade AL41F:
right: 514.0130.00/AL41F
left: L514.0130.00/AL41F (on demand)

SYSTEM 500

Nut-, Formzirkular- und
Trennfräsen

groove milling by
circular interpolation,
groove and slot milling

Typ 514

Fräswendeschnidplatten,
für Sicherungsringe DIN 471 / 472,
mit Nutaußenkantenfasung

indexable milling inserts,
for circlip groove DIN 471 / 472,
with chamfer

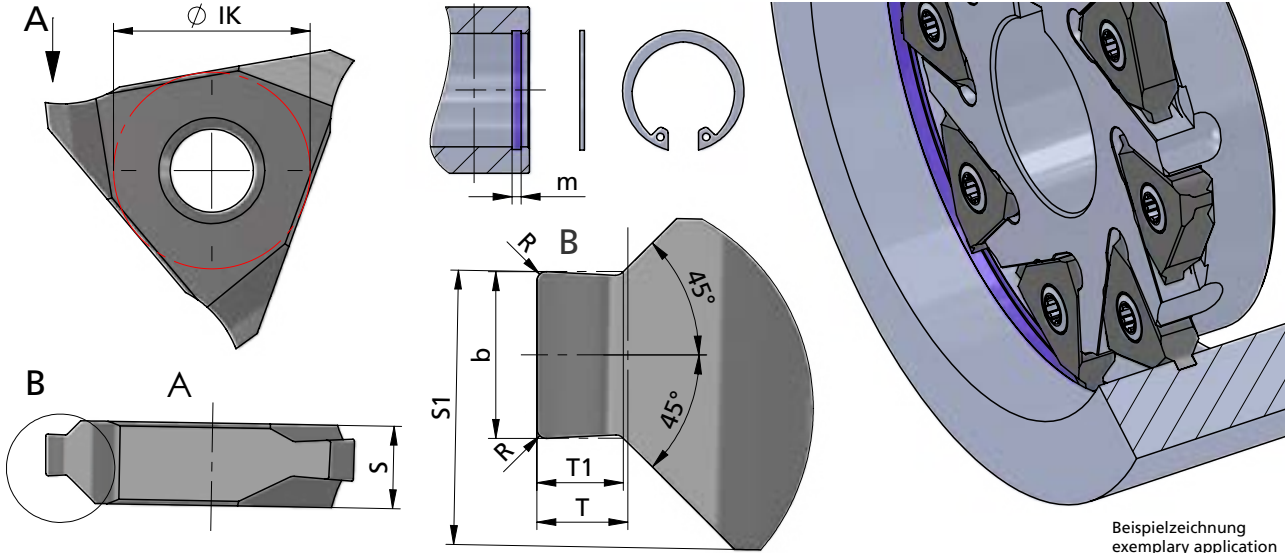

Beispielzeichnung
exemplary application

Abmessungen in mm

dimensions in mm

Bestellnummer part number	Nut-Maß m groove dim. m DIN 471 / DIN 472	S	S1 ±0.01	b -0.02	R	T1 -0.04 Formtiefe depth of form	T	Ø IK -0.03	K10F AL41F CN45F	für Fräseschaft / Messerkopf for milling shank / milling cutter
514.1105.35	1.1	5.4	4.52	1.21	0.1	0.49	0.50	13	● ● ●	500... 510... 581...
514.1307.35	1.3	5.4	4.62	1.41	0.1	0.67	0.70	13	● ● ●	
514.1308.35	1.3	5.4	4.62	1.41	0.1	0.83	0.85	13	● ● ●	
514.1609.35	1.6	5.4	4.52	1.71	0.15	0.83	0.85	13	● ● ●	
514.1610.35	1.6	5.4	4.52	1.71	0.15	0.97	1.00	13	● ● ●	
514.1812.35	1.85	5.4	4.64	1.96	0.15	1.23	1.25	13	● ● ●	
514.2115.43	2.15	5.4	4.79	2.26	0.15	1.47	1.50	13	● ● ●	
514.2616.43	2.65	5.4	4.54	2.76	0.15	1.47	1.50	13	● ● ●	
514.2617.43	2.65	5.4	4.54	2.76	0.15	1.72	1.75	13	● ● ●	
514.3118.53	3.15	5.4	4.79	3.26	0.15	1.72	1.75	13	● ● ●	
514.4120.53	4.15	5.4	4.99	4.26	0.15	1.97	2.00	13	● ● ●	
514.4125.53	4.15	5.4	4.99	4.26	0.15	2.47	2.50	13	● ● ●	
514.5130.61	5.15	6.1	5.85	5.26	0.15	2.97	3.00	13	● ● ●	

Weitere HM Sorten können Sie in der Sorten-
übersicht im Kapitel "Technische Hinweise" und
der Preisliste finden.

Bestellbeispiel für Sorte AL41F:
Rechts: 514.1105.35/AL41F
Links: L514.1105.35/AL41F (auf Anfrage)

More carbide grades you can find in the grades
summary in the chapter "technical instructions"
and in the price list.

order-example grade AL41F:
right: 514.1105.35/AL41F
left: L514.1105.35/AL41F (on demand)

SYSTEM 500

Nut-, Formzirkular- und
Trennfräsen

groove milling by
circular interpolation,
groove and slot milling

Typ 514

Fräswendeschnidplatten,
für metrisches ISO-Gewinde,
Teilprofil, innen

indexable milling inserts,
metric ISO-thread,
partial profile, internal

Steigung P = 1.5 - 6.0

pitch P = 1.5 - 6.0

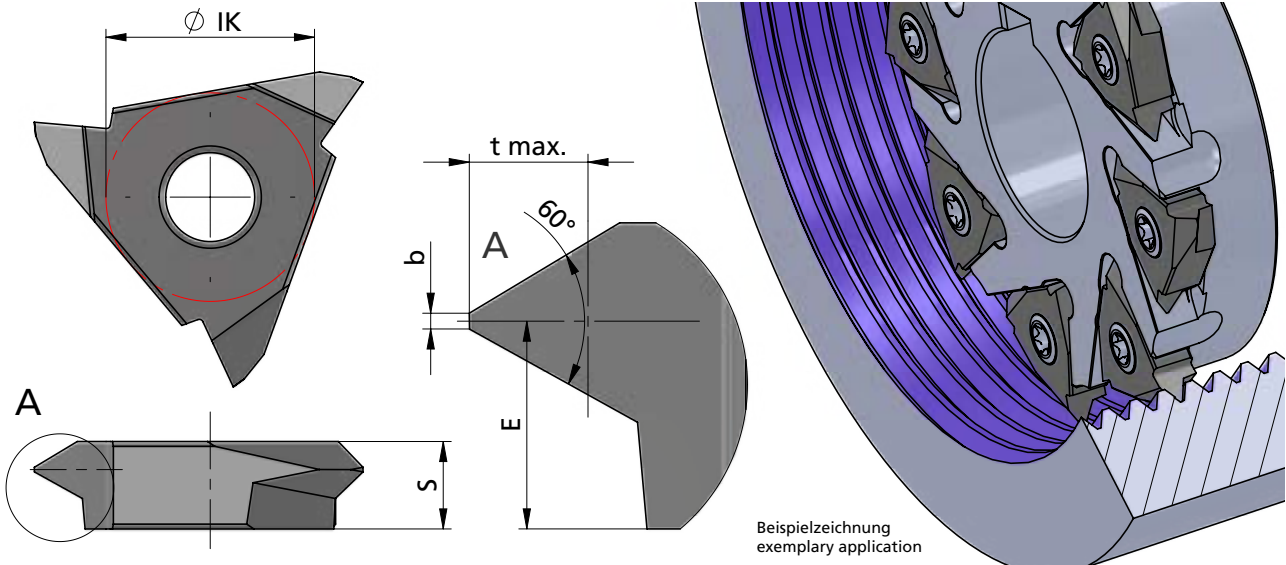

Beispielzeichnung
exemplary application

Abmessungen in mm

dimensions in mm



Bestellnummer part number	Steigung P pitch P	S	E	b	t max.	Ø IK -0.03	K10F AL41F P18C	für Fräseschaft / Messerkopf for milling shank / milling cutter
514.0815.01	1.5-1.5	5.4	4.60	0.19	0.81	13	●	
514.1020.01	2.0-2.0	5.4	4.40	0.25	1.08	13	●	
514.1535.01	1.5-3.5	5.4	3.90	0.18	1.89	13	●	
514.2140.01	3.5-4.0	5.4	3.70	0.43	2.17	13	●	500...
514.2445.01	3.75-4.5	5.4	3.40	0.47	2.44	13	●	510...
514.2750.01	4.0-5.0	5.4	3.35	0.50	2.70	13	●	581...
514.3260.01	4.5-6.0	5.4	3.00	0.56	3.25	13	●	
514.4060.01	3.5-6.0	5.4	3.00	0.44	3.52	13	●	

Weitere HM Sorten können Sie in der Sorten-
übersicht im Kapitel "Technische Hinweise" und
der Preisliste finden.

Bestellbeispiel:
für Sorte AL41F:
514.0815.01/AL41F

More carbide grades you can find in the grades
summary in the chapter "technical instructions"
and in the price list.

order-example:
grade AL41F:
514.0815.01/AL41F

SYSTEM 500

Nut-, Formzirkular- und
Trennfräsen

groove milling by
circular interpolation,
groove and slot milling

Typ 514

Fräswendeschnidplatten,
für metrisches ISO-Gewinde,
Vollprofil, innen

indexable milling inserts,
metric ISO-thread,
full profile, internal

Steigung P = 1.5 - 5.5

pitch P = 1.5 - 5.5

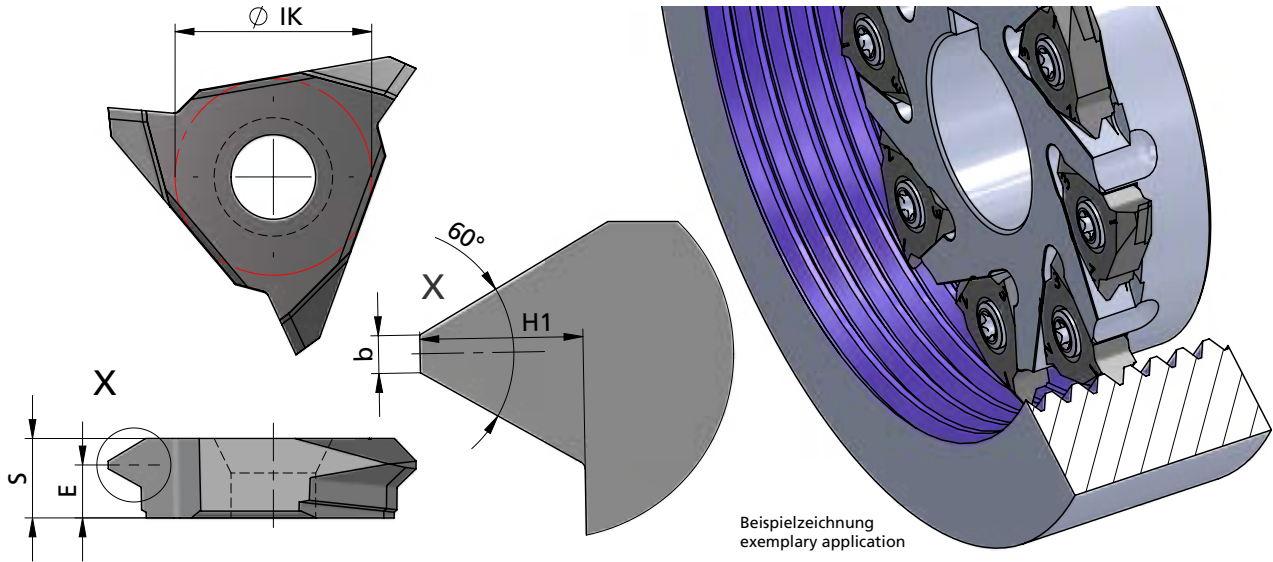

Beispielzeichnung
exemplary application

Abmessungen in mm

dimensions in mm

Bestellnummer part number	Steigung P pitch P	S	E	b	H1	Ø IK -0.03	K10F AL41F P18C	für Fräferschaft / Messerkopf for milling shank / milling cutter
514.0815.02	1.5	5.25	4.4	0.19	0.81	13	●	
514.1020.02	2.0	5.25	4.2	0.25	1.08	13	●	
514.1630.02	3.0	5.25	3.9	0.38	1.62	13	●	
514.1835.02	3.5	5.25	3.7	0.44	1.89	13	●	500...
514.2140.02	4.0	5.25	3.5	0.5	2.17	13	●	510...
514.2445.02	4.5	5.25	3.3	0.56	2.44	13	●	581...
514.2750.02	5.0	5.85	3.8	0.62	2.71	13	●	
514.2955.02	5.5	5.85	3.6	0.69	2.98	13	●	

Weitere HM Sorten können Sie in der Sorten-
übersicht im Kapitel "Technische Hinweise" und
der Preisliste finden.

Bestellbeispiel:
für Sorte AL41F:
514.0815.02/AL41F

More carbide grades you can find in the grades
summary in the chapter "technical instructions"
and in the price list.

order-example:
grade AL41F:
514.0815.02/AL41F

SYSTEM 500

Nut-, Formzirkular- und Trennfräsen

groove milling by circular interpolation, groove and slot milling

Typ 590... .6 / .8 / .10

Hochleistungsscheibenfräser mit Bohrung und Längsnut nach DIN 138

high performance disk-milling cutter with bore and longitudinal keyway according DIN 138

Nutbreite $b = 6 / 8 / 10$ mm
Nuttiefe t max. 50 mm
Schneidkreis- \emptyset DS ab 80 mm

width of groove $b = 6 / 8 / 10$ mm
depth of groove t max. 50 mm
cutting edge- \emptyset DS starting at 80 mm

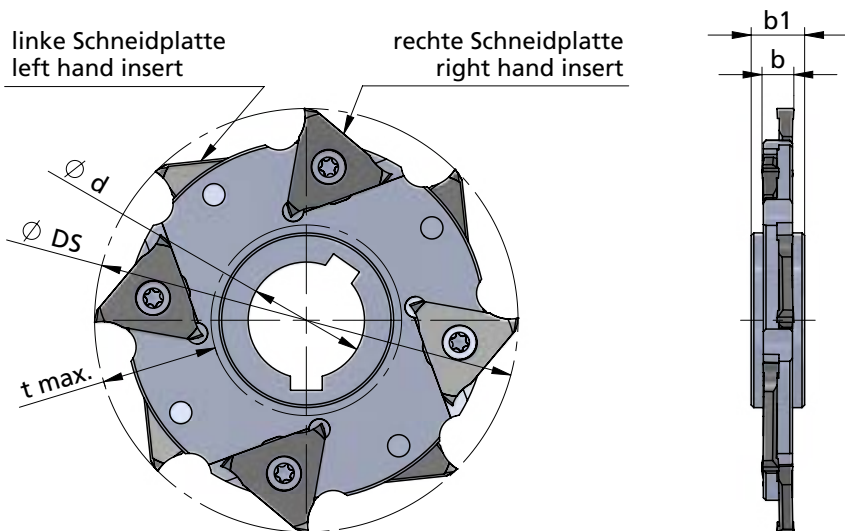

Beispielzeichnung
exemplary application

weitere Abmessungen auf Anfrage

further sizes upon request

Abmessungen in mm

dimensions in mm



Bestellnummer part number	$\emptyset DS$	$\emptyset d$	b	$b1$	$t max.$	Spannschraube screw	Schraubenschlüssel key driver	Anzugs- drehmoment torque	Anzahl Schneidplatten R/L number inserts R/L	Schneidplatte insert type
590.0080.22.6	80	22	6	10	22	A.SPS008	TR15	5.0	4/4	R/L 514.0632.00
590.0080.27.6	80	27	6	10	21	A.SPS008	TR15	5.0	4/4	R/L 514.0632.00
590.0080.27.8	80	27	8	12	21	A.SPS009	TR20	5.0	4/4	R/L 514.0843.00
590.0080.27.10	80	27	10	12	21	A.SPS010	TR20-P	6.0	4/4	R/L 514.1054.00
590.0100.32.6	100	32	6	10	25.5	A.SPS008	TR15	5.0	5/5	R/L 514.0632.00
590.0100.32.8	100	32	8	12	25.5	A.SPS009	TR20	5.0	5/5	R/L 514.0843.00
590.0100.32.10	100	32	10	12	25.5	A.SPS010	TR20-P	6.0	5/5	R/L 514.1054.00
590.0125.40.6	125	40	6	10	32.5	A.SPS008	TR15	5.0	6/6	R/L 514.0632.00
590.0125.40.8	125	40	8	12	32.5	A.SPS009	TR20	5.0	6/6	R/L 514.0843.00
590.0125.40.10	125	40	10	14	32.5	A.SPS010	TR20-P	6.0	6/6	R/L 514.1054.00
590.0160.40.6	160	40	6	10	50	A.SPS008	TR15	5.0	8/8	R/L 514.0632.00
590.0160.40.8	160	40	8	12	50	A.SPS009	TR20	5.0	8/8	R/L 514.0843.00
590.0160.40.10	160	40	10	14	50	A.SPS010	TR20-P	6.0	8/8	R/L 514.1054.00

Achtung:
Schneidplatten sind nicht im Lieferumfang enthalten!

Attention:
Inserts are not included in the scope of delivery!

Bestellbeispiel:
590.0080.22.6

order-example:
590.0080.22.6

SYSTEM 500

Nut-, Formzirkular- und
Trennfräsen

groove milling by
circular interpolation,
groove and slot milling

Typ 591... .6

Hochleistungs
Aufsteck-Scheibenfräser

high performance
arbor mounted
disk-milling cutter

Nutbreite $b = 6$ mm
Nuttiefe t max. 25 / 37.5 mm
Schneidkreis- \emptyset DS 100 / 125 mm

width of groove $b = 6$ mm
depth of groove t max. 25 / 37.5 mm
cutting edge- \emptyset DS 100 / 125 mm

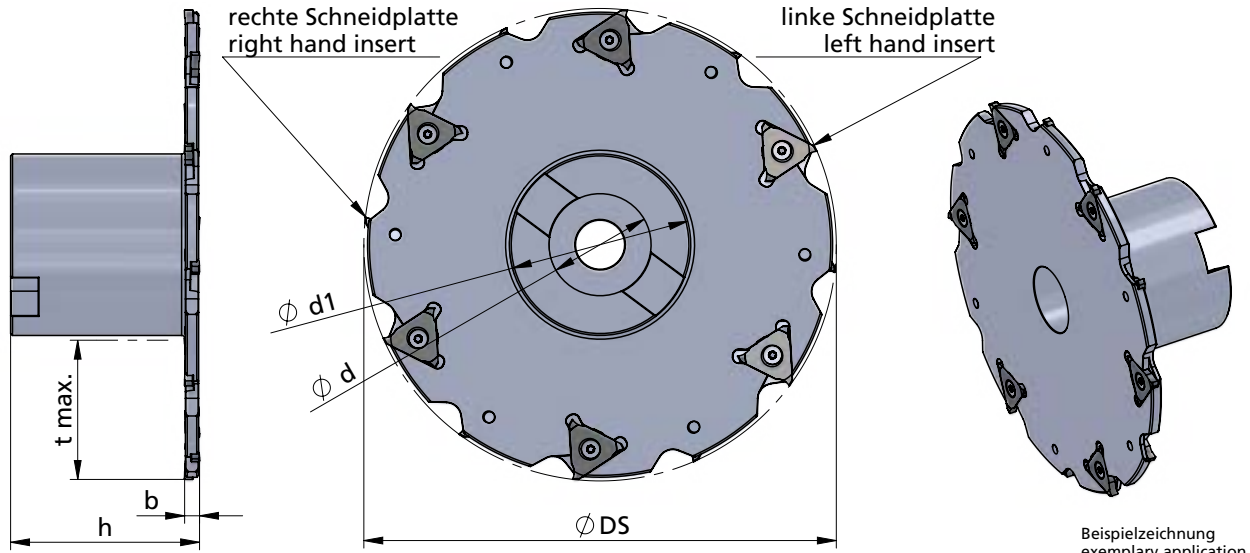

Beispielzeichnung
exemplary application

weitere Abmessungen auf
Anfrage

further sizes upon request

Abmessungen in mm

dimensions in mm

Bestellnummer part number	Ø DS	Ø d	Ø d1	b	h	t max.	Befestigung/fixing			Anzahl Schneidplatten R/L number inserts R/L	Schneidplatte insert type	
							Spannschraube screw	Schraubenschlüssel wrench	Anzugs- drehmoment torque			
591.0100.27.6	100	27	48	6	50	25	A.SPS008	TR15	5.0 Nm	A.SPS002 A.SBE002	5/5	R/L 514.0632.00
591.0125.27.6	125	27	48	6	50	37.5	A.SPS008	TR15	5.0 Nm	A.SPS002 A.SBE002	6/6	R/L 514.0632.00

Achtung:
Schneidplatten sind nicht im Lieferumfang
enthalten!

Attention:
Inserts are not included in the scope of delivery!

Bestellbeispiel:
591.0100.27.6

order-example:
591.0100.27.6

SYSTEM 500

Nut-, Formzirkular- und Trennfräsen

groove milling by circular interpolation, groove and slot milling

Typ 514

Fräswendeschneidplatten

indexable milling inserts

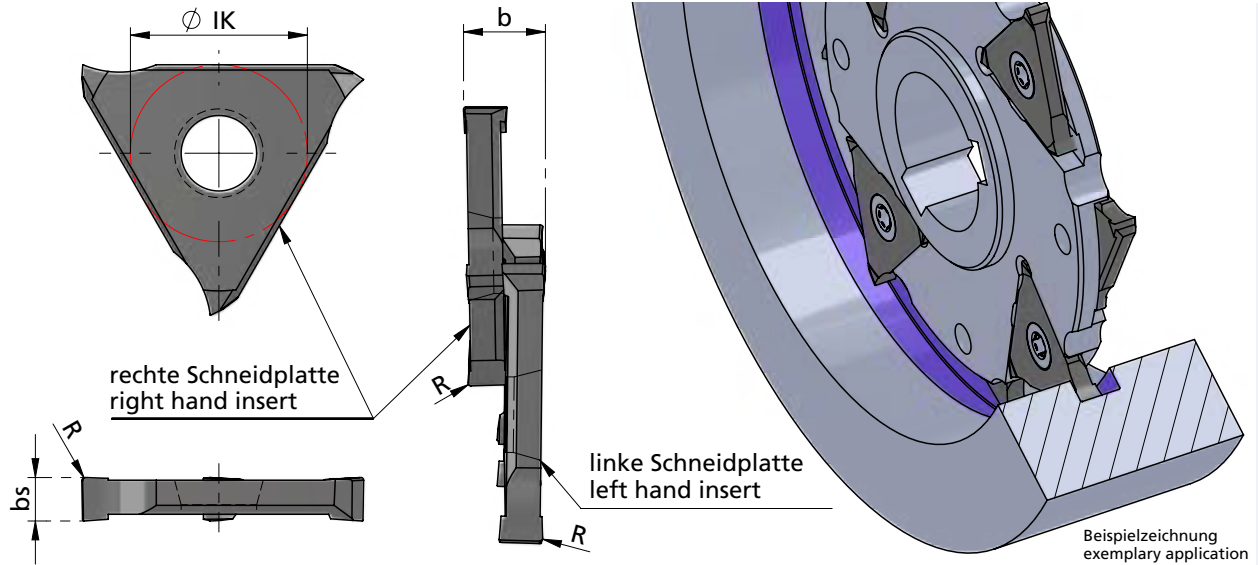

Rechts (R): wie gezeichnet
Links (L): spiegelbildlich

righthand (R): as shown
lefthand (L): mirror image

Abmessungen in mm

dimensions in mm



Bestellnummer part number	b für Nutbreite b width of groove	bs	R	Ø IK	K10F AL41F CN45F	für Scheibenfräser for disk milling cutter
R/L 514.0632.00	6	3.2	0.2	13	● ● ●	
R/L 514.0843.00	8	4.3	0.2	13	● ● ●	590... 591...
R/L 514.1054.00	10	5.4	0.2	13	● ● ●	

Weitere HM Sorten können Sie in der Sortenübersicht im Kapitel "Technische Hinweise" und der Preisliste finden.

Bestellbeispiel:
für rechte Ausführung und Sorte
R514.0632.00/AL41F

More carbide grades you can find in the grades summary in the chapter "technical instructions" and in the price list.

order-example:
righthand version and grade
R514.0632.00/AL41F

SYSTEM 500

Nut-, Formzirkular- und Trennfräsen

groove milling by circular interpolation, groove and slot milling

Typ 590... .3 / .4 / .5

Hochleistungstrennfräser mit Bohrung und Längsnut nach DIN 138

high performance slotting cutter with bore and longitudinal keyway according DIN 138

Nutbreite $b = 3 / 4 / 5$ mm
Nuttiefe t max. 50 mm
Schneidkreis-Ø DS ab 80 mm

width of groove $b = 3 / 4 / 5$ mm
depth of groove t max. 50 mm
cutting edge-Ø DS starting at 80 mm

linke Schneidplatte
left hand insert

rechte Schneidplatte
right hand insert

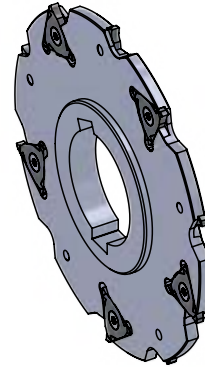
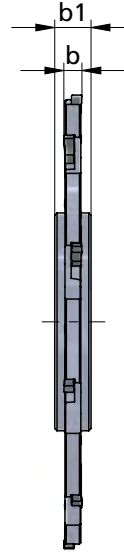
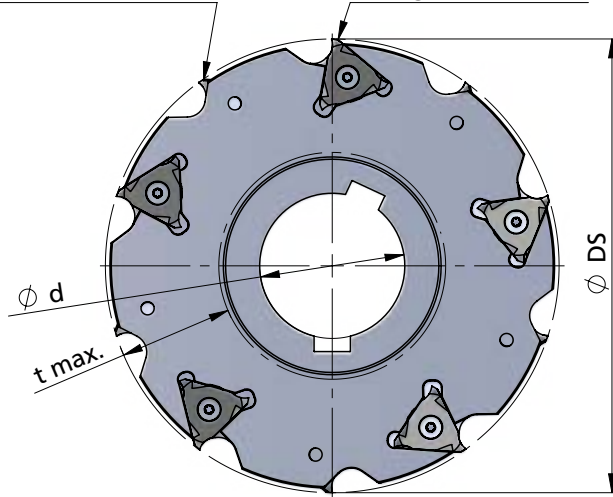

Beispielzeichnung
exemplary application

weitere Abmessungen auf Anfrage

further sizes upon request

Abmessungen in mm

dimensions in mm

Bestellnummer part number	Ø DS	Ø d	b	b1	t max.	Spannschraube screw	Schraubenschlüssel key driver	Anzugs- drehmoment torque	Anzahl Schneidplatten R/L number inserts R/L	Schneidplatte insert type
590.0080.27.3	80	27	3	8	18	A.SPS005	DSD-TX7/07	0.7	4/4	R/L 510.0317
590.0100.32.3	100	32	3	8	25	A.SPS005	DSD-TX7/07	0.7	5/5	R/L 510.0317
590.0125.40.3	125	40	3	10	32	A.SPS005	DSD-TX7/07	0.7	6/6	R/L 510.0317
590.0160.40.3	160	40	3	10	50	A.SPS005	DSD-TX7/07	0.7	8/8	R/L 510.0317
590.0080.27.4	80	27	4	8	18	A.SPS006	TR8	1.3	4/4	R/L 510.0423
590.0100.32.4	100	32	4	8	25	A.SPS006	TR8	1.3	5/5	R/L 510.0423
590.0125.40.4	125	40	4	10	32	A.SPS006	TR8	1.3	6/6	R/L 510.0423
590.0160.40.4	160	40	4	10	50	A.SPS006	TR8	1.3	8/8	R/L 510.0423
590.0080.27.5	80	27	5	8	18	A.SPS007	TR8	1.3	4/4	R/L 510.0528
590.0100.32.5	100	32	5	8	25	A.SPS007	TR8	1.3	5/5	R/L 510.0528
590.0125.40.5	125	40	5	10	32	A.SPS007	TR8	1.3	6/6	R/L 510.0528
590.0160.40.5	160	40	5	10	50	A.SPS007	TR8	1.3	8/8	R/L 510.0528

Achtung:
Schneidplatten sind nicht im Lieferumfang enthalten!

Attention:
Inserts are not included in the scope of delivery!

Bestellbeispiel:
590.0080.27.3

order-example:
590.0080.27.3

SYSTEM 500

Nut-, Formzirkular- und Trennfräsen

groove milling by circular interpolation, groove and slot milling

Typ 591... .3

Hochleistungs Aufsteck-Trennfräser mit Bohrung und Quernut nach DIN 138

high performance arbor mounted slotting cutter with bore and cross keyway according DIN 138

Nutbreite $b = 3$ mm
Nuttiefe t max. 44 mm
Schneidkreis- \emptyset DS ab 63 mm

width of groove $b = 3$ mm
depth of groove t max. 44 mm
cutting edge- \emptyset DS starting at 63 mm

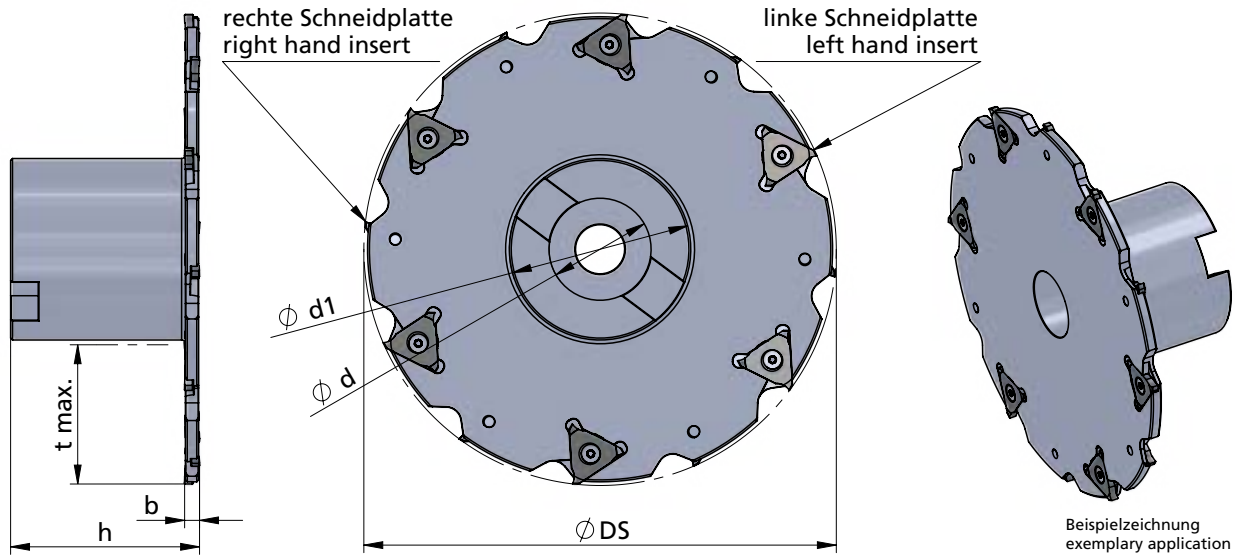

weitere Abmessungen auf Anfrage

further sizes upon request

Abmessungen in mm

dimensions in mm



Bestellnummer part number	Ø DS	Ø d	b	Ø d1	h	t max.	Spannschraube screw	Schraubenschlüssel wrench	Anzugs- drehmoment torque	Befestigung/fixing		Anzahl Schneidplatten R/L number inserts R/L	Schneidplatte insert type
										Spannschraube screw	Unterleg- scheibe washer		
591.0063.16.3	63	16	3	27	50	17.5	A.SPS005	DSD-TX7/07	0.7 Nm	A.SPS003	A.SBE001	4/4	R/L 510.0317
591.0080.16.3	80	16	3	28	50	25				A.SPS002	A.SBE002	4/4	
591.0100.27.3	100	27	3	48	50	25				A.SPS001	A.SBE003	5/5	
591.0125.27.3	125	27	3	48	50	37.5				6/6			
591.0160.40.3	160	40	3	70	50	44				8/8			

Achtung:
Schneidplatten sind nicht im Lieferumfang enthalten!

Attention:
Inserts are not included in the scope of delivery!

Bestellbeispiel:
591.0063.16.3

order-example:
591.0063.16.3

SYSTEM 500

Nut-, Formzirkular- und
Trennfräsen

groove milling by
circular interpolation,
groove and slot milling

Typ 591... 3-IK

Hochleistungs Aufsteck-Trennfräser
mit Bohrung und Quernut nach DIN 138
und innerer Kühlmittelzufuhr

high performance arbor mounted
slotting cutter with bore and cross
keyway according to DIN 138
and internal coolant supply

Nutbreite $b = 3$ mm
Nuttiefe t max. 44 mm
Schneidkreis-Ø DS ab 63 mm

width of groove $b = 3$ mm
depth of groove t max. 44 mm
cutting edge-Ø DS starting at 63 mm

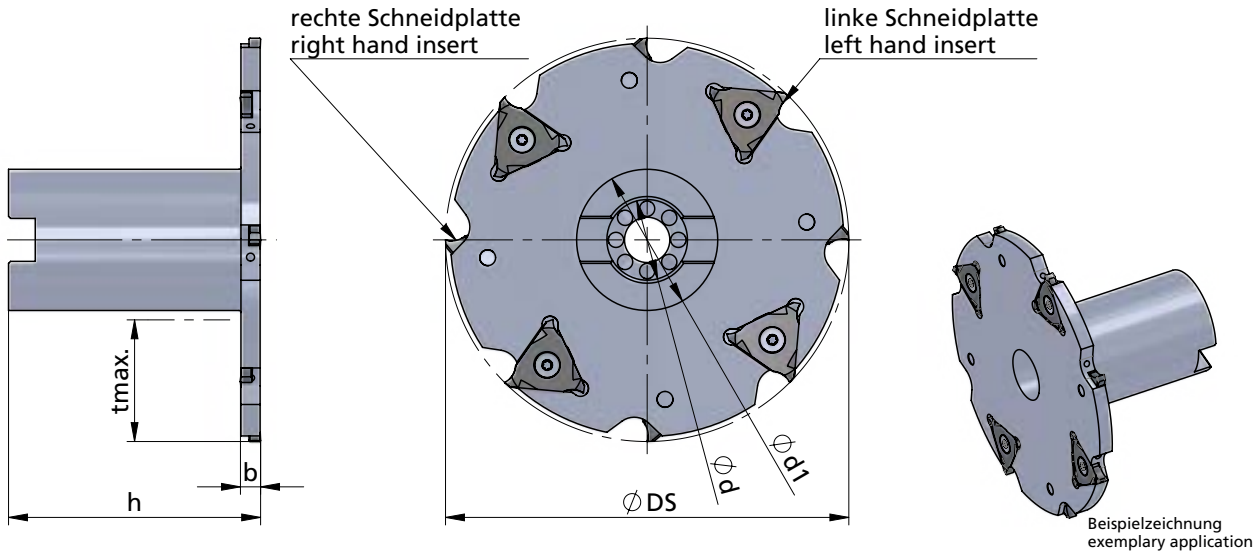

weitere Abmessungen auf
Anfrage

further sizes upon request

Abmessungen in mm

dimensions in mm



Bestellnummer part number	Ø DS	Ø d	b	Ø d1	h	t max.	Spannschraube clamping screw	Schraubenschlüssel wrench	Anzugs- drehmoment torque	Befestigung/fixing		Anzahl Schneidplatten R/L number inserts R/L	Schneidplatte insert type
										Spannschraube clamping screw	Unterleg- scheibe washer		
591.0063.16.3-IK	63	16	3	27	50	17.5	A.SPS005	DSD-TX7/07	0.7 Nm	A.SPS033	-	4/4	R/L 510.0317
591.0080.16.3-IK	80	16	3	28	50	25.0				A.SPS034	-	5/5	
591.0100.27.3-IK	100	27	3	48	50	25.0				-	-	6/6	
591.0125.27.3-IK	125	27	3	48	50	37.5				-	-	8/8	
591.0160.40.3-IK	160	40	3	70	50	44.0				A.SPS001	-	8/8	

Achtung:
Schneidplatten sind nicht im Lieferumfang
enthalten!

Attention:
Inserts are not included in the scope of delivery!

SYSTEM 500

Nut-, Formzirkular- und Trennfräsen

groove milling by circular interpolation, groove and slot milling

Typ 591... .4

Hochleistungs Aufsteck-Trennfräser mit Bohrung und Quernut nach DIN 138

high performance arbor mounted slotting cutter with bore and cross keyway according DIN 138

Nutbreite $b = 4$ mm
Nuttiefe t max. 64 mm
Schneidkreis- \varnothing DS ab 63 mm

width of groove $b = 4$ mm
depth of groove t max. 64 mm
cutting edge- \varnothing DS starting at 63 mm

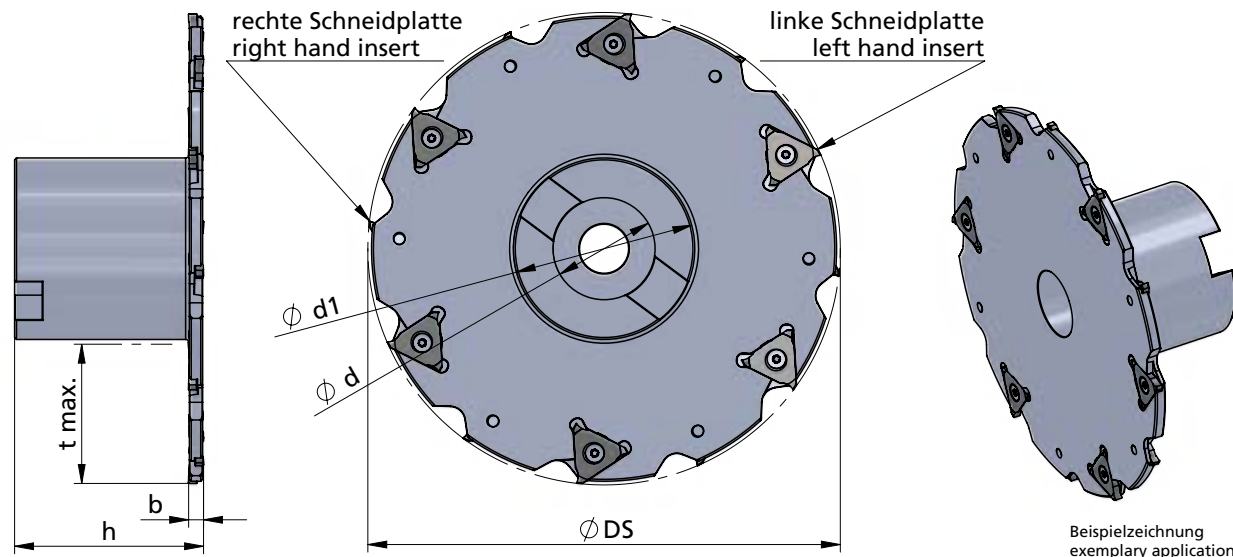

weitere Abmessungen auf Anfrage

further sizes upon request

Abmessungen in mm

dimensions in mm



Bestellnummer part number	\varnothing DS	\varnothing d	b	\varnothing d1	h	t max.	Spannschraube screw	Schraubenschlüssel wrench	Anzugs- drehmoment torque	Befestigung/fixing		Anzahl Schneidplatten R/L number inserts R/L	Schneidplatte insert type
										Spannschraube screw	Unterleg- scheibe washer		
591.0063.16.4	63	16	4	27	50	17.5	A.SPS006	TR8	1.3 Nm	A.SPS003	A.SBE001	4/4	R/L 510.0423
591.0080.16.4	80	16	4	28	50	25				A.SPS002	A.SBE002	4/4	
591.0100.27.4	100	27	4	48	50	25				A.SPS002	A.SBE002	5/5	
591.0125.27.4	125	27	4	48	50	37.5				A.SPS001	A.SBE003	6/6	
591.0125.40.4	125	40	4	70	50	26.5				A.SPS001	A.SBE003	6/6	
591.0160.27.4	160	4	48	50	55	A.SPS002				A.SBE002	8/8		
591.0160.40.4	160	4	70	50	44	A.SPS002				A.SBE002	8/8		
591.0180.40.4	180	4	70	50	54	A.SPS001				A.SBE003	9/9		
591.0200.40.4	200	4	70	50	64	A.SPS001				A.SBE003	10/10		

Achtung:
Schneidplatten sind nicht im Lieferumfang
enthalten!

Attention:
Inserts are not included in the scope of delivery!

Bestellbeispiel:
591.0063.16.4

order-example:
591.0063.16.4

SYSTEM 500

Nut-, Formzirkular- und
Trennfräsen

groove milling by
circular interpolation,
groove and slot milling

Typ 591... .4-IK

Hochleistungs Aufsteck-Trennfräser
mit Bohrung und Quernut nach DIN 138
und innerer Kühlmittelzufuhr

high performance arbor mounted
slotting cutter with bore and cross
keyway according to DIN 138
and internal coolant supply

Nutbreite $b = 4$ mm
Nuttiefe t max. 55 mm
Schneidkreis-Ø DS ab 63 mm

width of groove $b = 4$ mm
depth of groove t max. 55 mm
cutting edge-Ø DS starting at 63 mm

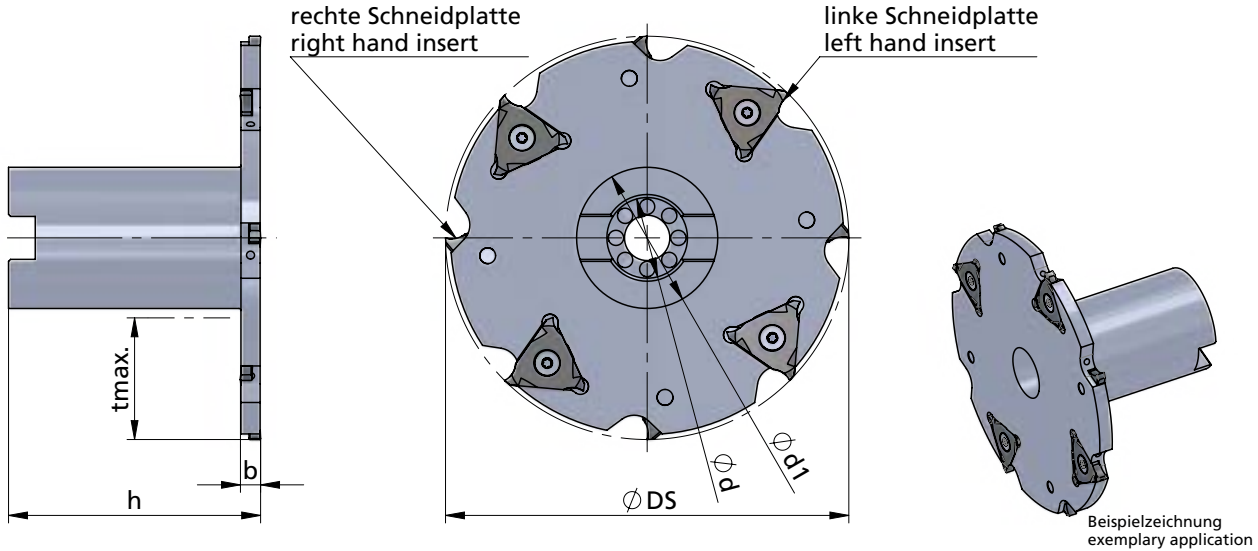

Beispielzeichnung
exemplary application

weitere Abmessungen auf
Anfrage

further sizes upon request

Abmessungen in mm

dimensions in mm



Bestellnummer part number	Ø DS	Ø d	b	Ø d1	h	t max.	Spannschraube clamping screw	Schraubenschlüssel wrench	Anzugs- drehmoment torque	Befestigung / fixing		Anzahl Schneidplatten R/L number inserts R/L	Schneidplatte insert type
										Spannschraube clamping screw	Unterleg- scheibe washer		
591.0063.16.4-IK	63	16	4	27	50	17.5	A.SPS006	TR8	1.3 Nm	A.SPS033	-	4/4	R/L 510.0423
591.0080.16.4-IK	80	16	4	28	50	25.0				A.SPS034	-	6/6	
591.0100.27.4-IK	100	27	4	48	50	25.0	A.SPS006	TR8	1.3 Nm	A.SPS034	-	5/5	R/L 510.0423
591.0125.27.4-IK	125	27	4	48	50	37.5						6/6	
591.0160.27.4-IK	160	27	4	48	50	55.0						8/8	

Achtung:
Schneidplatten sind nicht im Lieferumfang
enthalten!

Attention:
Inserts are not included in the scope of delivery!

Bestellbeispiel:
591.0063.16.4-IK

order-example:
591.0063.16.4-IK

SYSTEM 500

Nut-, Formzirkular- und Trennfräsen

groove milling by circular interpolation, groove and slot milling

Typ 591... .5

Hochleistungs Aufsteck-Trennfräser mit Bohrung und Quernut nach DIN 138

high performance arbor mounted slotting cutter with bore and cross keyway according DIN 138

Nutbreite $b = 5\text{ mm}$
Nuttiefe $t\text{ max. } 37.5\text{ mm}$
Schneidkreis- \emptyset DS ab 100 mm

width of groove $b = 5\text{ mm}$
depth of groove $t\text{ max. } 37.5\text{ mm}$
cutting edge- \emptyset DS starting at 100 mm

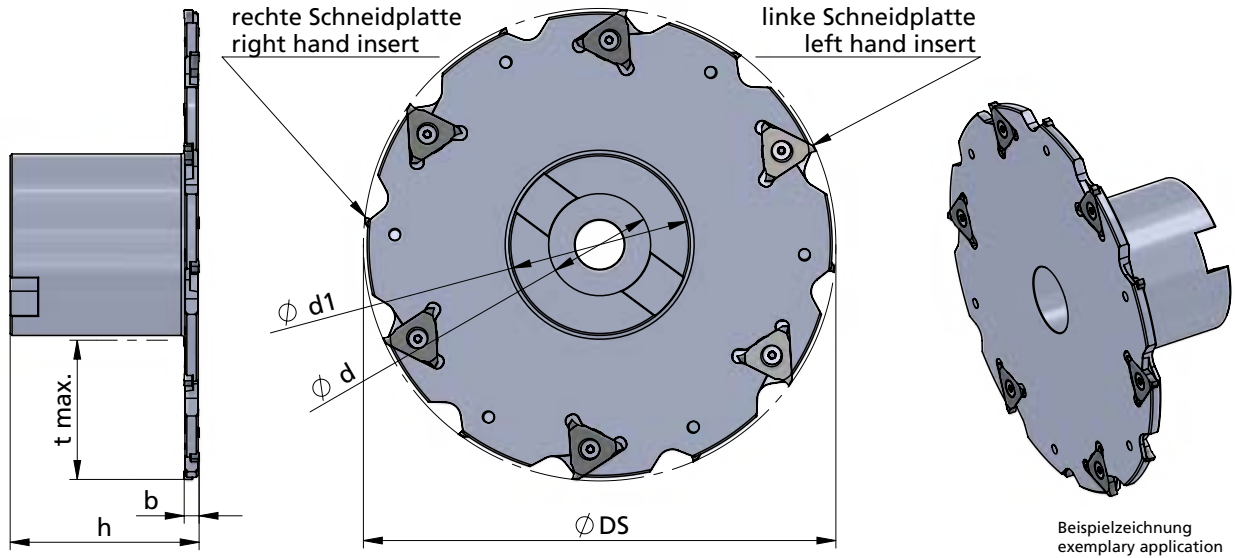

weitere Abmessungen auf Anfrage

further sizes upon request

Abmessungen in mm

dimensions in mm



Bestellnummer part number	Ø DS	Ø d	b	Ø d1	h	t max.	Befestigung/fixing			Anzahl Schneidplatten R/L number inserts R/L	Schneidplatte insert type		
							Spannschraube screw	Schraubenschlüssel wrench	Anzugs- drehmoment torque			Spannschraube screw	Unterleg- scheibe washer
591.0100.27.5	100	27	5	48	50	25	A.SPS007	TR8	1.3 Nm	A.SPS002	A.SBE002	5/5	R/L 510.0528
591.0125.27.5	125	27	5	48	50	37.5	A.SPS007	TR8	1.3 Nm	A.SPS002	A.SBE002	6/6	R/L 510.0528

Achtung:
Schneidplatten sind nicht im Lieferumfang enthalten!

Attention:
Inserts are not included in the scope of delivery!

Bestellbeispiel:
591.0100.27.5

order-example:
591.0100.27.5

SYSTEM 500

Nut-, Formzirkular- und
Trennfräsen

groove milling by
circular interpolation,
groove and slot milling

Typ 510

Fräswendeschnidplatten

indexable milling insets

für Hochleistungstrennfräser Typ 590
und Hochleistungs
Aufsteck-Trennfräser Typ 591(-IK)

for high performance
slotting cutter type 590 and
high performance arbor mounted
slotting cutter type 591(-IK)

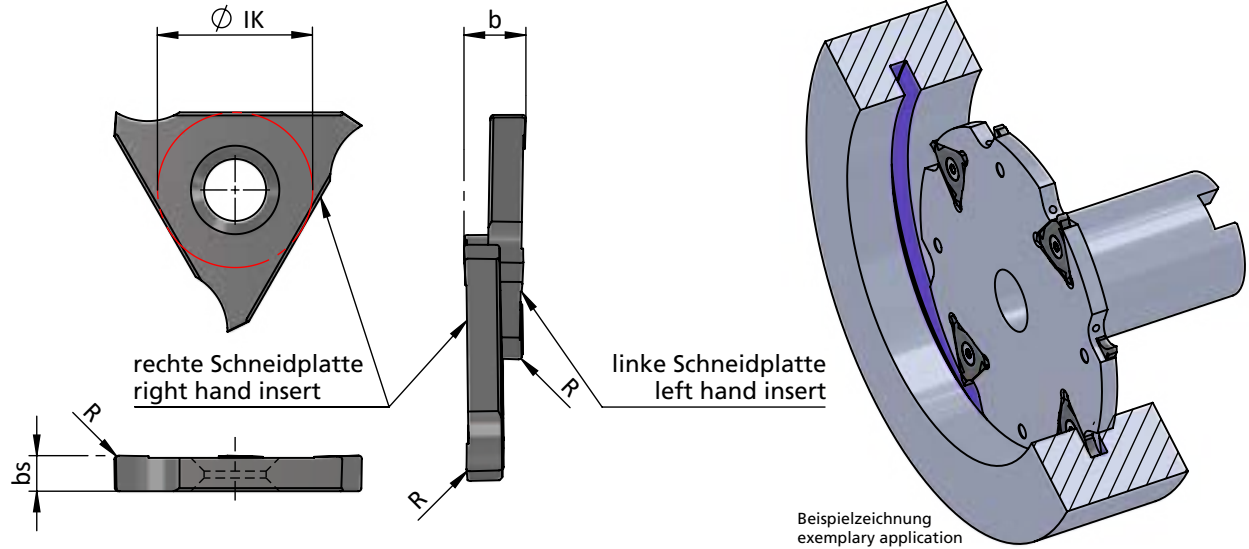

Rechts (R): wie gezeichnet
Links (L): spiegelbildlich

righthand (R): as shown
lefthand (L): mirror image

Abmessungen in mm

dimensions in mm

Bestellnummer part number	b für Nutbreite b width of groove	bs	R	Ø IK	K10F AL41F P18C-X *	für Trennfräser for slotting cutter
R/L 510.0317	3	1.7	0.15	10	● ● ●	590.....3 591.....3 591.....3-IK
R/L 510.0423	4	2.3	0.2	10	● ● ●	590.....4 591.....4 591.....4-IK
R/L 510.0528	5	2.8	0.2	10	● ● ●	590.....5 591.....5

Weitere HM Sorten können Sie in der Sorten-
übersicht im Kapitel "Technische Hinweise" und
der Preisliste finden.

* Fräswendeschnidplatte
mit Hochleistungsschneidkante
extra stabile Ausführung

More carbide grades you can find in the grades
summary in the chapter "technical instructions"
and in the price list.

Bestellbeispiel:
für Sorte AL41F:
R510.0317/AL41F

indexable milling insert
with high performance cutting edge
extra strong design

order-example:
grade AL41F:
R510.0317/AL41F

SYSTEM 500

Nut-, Formzirkular- und Trennfräsen

groove milling by circular interpolation, groove and slot milling

Typ 550.063.00

VHM - Hochleistungsscheibenfräser

carbide high performance disk-milling cutter

Nutbreite $b = 2 - 10 \text{ mm}$
 Nuttiefe $t \text{ max. } 15 \text{ mm}$
 Schneidkreis-Ø DS 63 mm

width of groove $b = 2 - 10 \text{ mm}$
 depth of groove $t \text{ max. } 15 \text{ mm}$
 cutting edge-Ø DS 63 mm



kreuzverzahnt / staggered-toothed

Beispielzeichnung
exemplary application

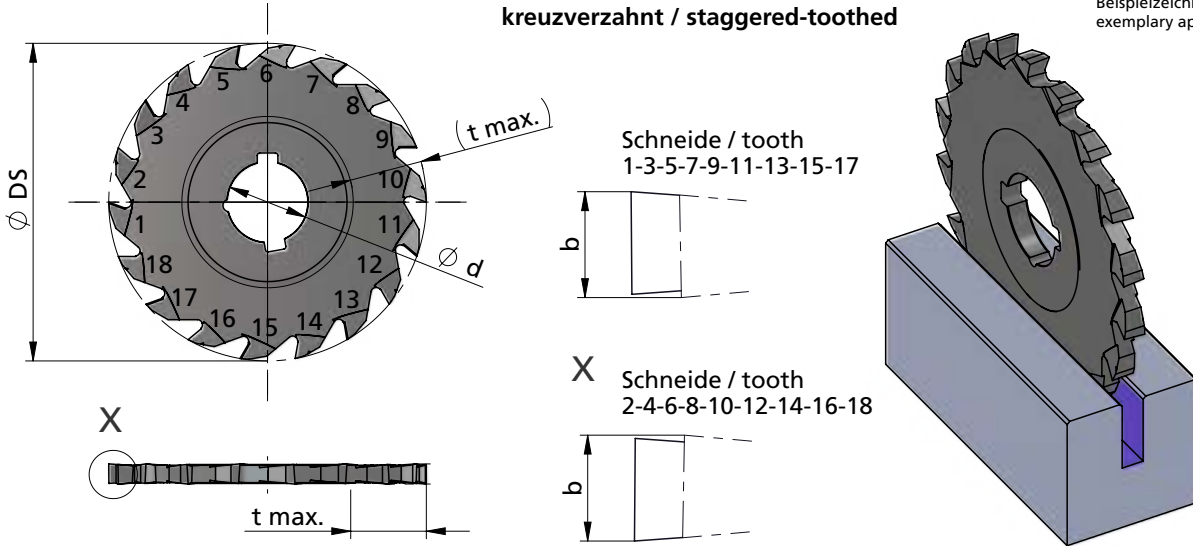

Abmessungen in mm

dimensions in mm



Bestellnummer part number	Ø DS	Ø d	b	t max.	Zähnezahl number of teeth	K10F	P04C
550.063.020.00	63	16	2.0	15	18	●	●
550.063.025.00	63	16	2.5	15	18	●	●
550.063.030.00	63	16	3.0	15	18	●	●
550.063.040.00	63	16	4.0	15	18	●	●
550.063.050.00	63	16	5.0	15	18	●	●
550.063.060.00	63	16	6.0	15	18	●	●
550.063.080.00	63	16	8.0	15	18	●	●
550.063.100.00	63	16	10.0	15	18	●	●

Weitere HM Sorten können Sie in der Sortenübersicht im Kapitel "Technische Hinweise" und der Preisliste finden.

Bestellbeispiel:
für Sorte P04C:
550.063.020.00/P04C

More carbide grades you can find in the grades summary in the chapter "technical instructions" and in the price list.

order-example:
grade P04C:
550.063.020.00/P04C

SYSTEM 500

Nut-, Formzirkular- und Trennfräsen

groove milling by circular interpolation, groove and slot milling

Typ 550.063.20

VHM - Hochleistungscheibenfräser, mit Eckenradius

carbide high performance disk-milling cutter, with corner radius

Nutbreite $b = 2 - 10$ mm
Nuttiefe t max. 15 mm
Schneidkreis- \emptyset DS 63 mm

width of groove $b = 2 - 10$ mm
depth of groove t max. 15 mm
cutting edge- \emptyset DS 63 mm

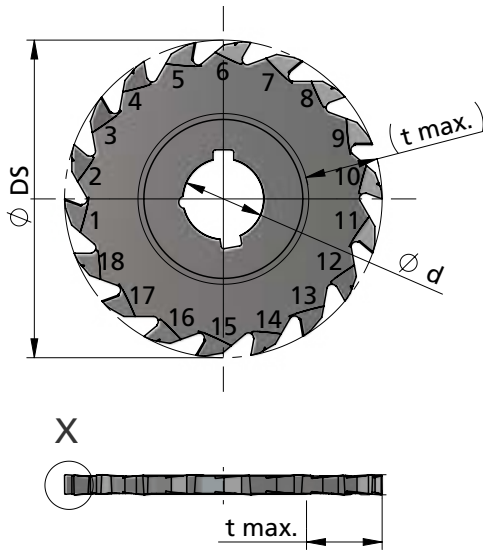

kreuzverzahnt / staggered-toothed

Schneide / tooth
1-3-5-7-9-11-13-15-17

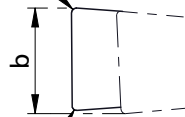

X
Schneide / tooth
2-4-6-8-10-12-14-16-18

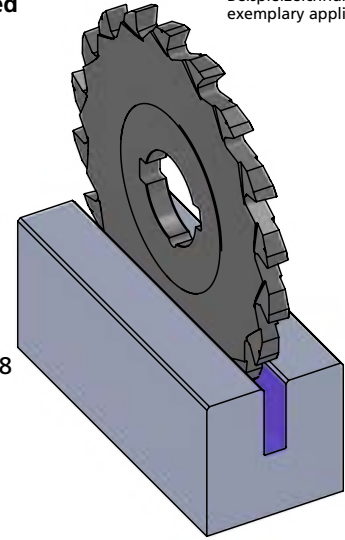
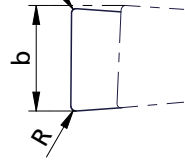

Beispielzeichnung
exemplary application

Abmessungen in mm

dimensions in mm

Bestellnummer part number	\emptyset DS	\emptyset d	b	R	t max.	Zähnezahl number of teeth	K10F	P04C
550.063.020.20	63	16	2.0	0.2	15	18	●	●
550.063.025.20	63	16	2.5	0.2	15	18	●	●
550.063.030.20	63	16	3.0	0.2	15	18	●	●
550.063.040.20	63	16	4.0	0.2	15	18	●	●
550.063.050.20	63	16	5.0	0.2	15	18	●	●
550.063.060.20	63	16	6.0	0.2	15	18	●	●
550.063.080.20	63	16	8.0	0.2	15	18	●	●
550.063.100.20	63	16	10.0	0.2	15	18	●	●

Weitere HM Sorten können Sie in der Sortenübersicht im Kapitel "Technische Hinweise" und der Preisliste finden.

Bestellbeispiel:
für Sorte P04C:
550.063.020.20/P04C

More carbide grades you can find in the grades summary in the chapter "technical instructions" and in the price list.

order-example:
grade P04C:
550.063.020.20/P04C

SYSTEM 500

Nut-, Formzirkular- und
Trennfräsen

groove milling by
circular interpolation,
groove and slot milling

Technische Hinweise

Grundsätzliche Informationen zum Gewindefräsen

Technical instructions,
basic informations about thread milling

Vor- und Nachschnitt

Beim Zirkularfräsen von Gewinden entsteht durch die Steigung ein Vor- und Nachschnitt. Um hier die Verletzung des Gewindeprofils so gering wie möglich zu halten muß ein Werkzeug mit einem möglichst kleinen Schneidkreis gewählt werden.

Die nachfolgende Skizze zeigt die Verhältnisse bei der Bearbeitung:

(Grün: Konturverletzung X gering = gut; Rot: Konturverletzung X erheblich = schlecht)

Thread profile violation

Thread milling by interpolation causes a profile violation. To keep the violation minimal you should use the cutting circle as small as possible.

The following sketch shows the relations during the process:

(green: profile violation X low = good; red: profile violation X big = bad)

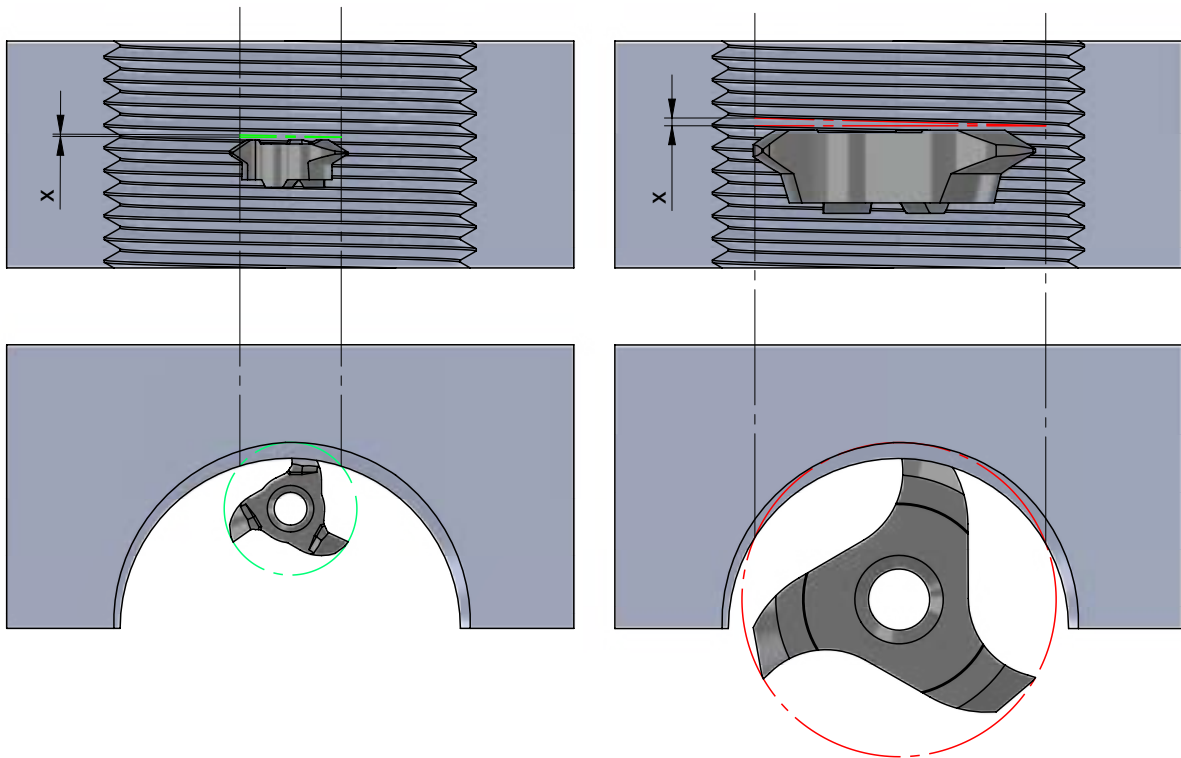

SYSTEM 500

Nut-, Formzirkular- und
Trennfräsen

groove milling by
circular interpolation,
groove and slot milling

Technische Hinweise

Grundsätzliche Informationen zum Gewindefräsen

Technical instructions,
basic informations about thread milling

Teilprofil

Werkzeuge mit Teilprofil sind Mehrbereichswerkzeuge, d.h. mit diesem Werkzeug können Gewinde mit unterschiedlichen Steigungen hergestellt werden. Dies ist aber nur mit einer kleinen Abweichung vom Normprofil möglich. Abgestimmt ist das Werkzeug auf die kleinste angegebene Steigung, dieses Profil kann ohne Abweichung produziert werden. Alle weiteren Steigungen können ebenfalls produziert werden, hier weicht aber das gefertigte Profil gegenüber der Norm durch eine höhere Gewindetiefe ab. In der Regel ist dies unproblematisch, muß aber gegebenenfalls im Einzelfall genauer betrachtet werden.

Partial profile

Tools with partial profile are multi-purpose tools, that means you can process several pitches with one tool. The processed shape has a small difference to the standard profile. Created is that tool for the smallest pitch, this profile depends to the standard.

All other pitches are producible, but only with a small deviation. Normally this causes no problem, but sometimes you have to decide case by case.

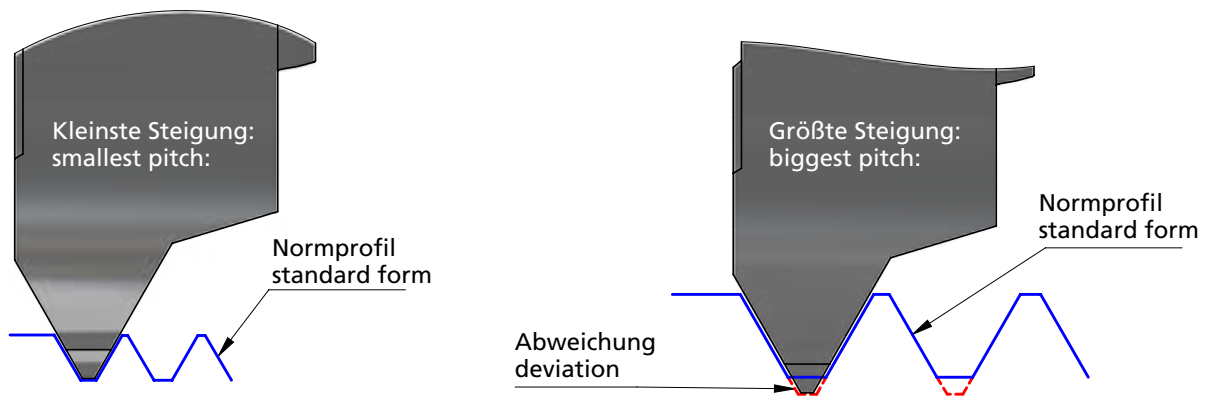

SYSTEM 500

Nut-, Formzirkular- und
Trennfräsen

groove milling by
circular interpolation,
groove and slot milling

Technische Hinweise

Grundsätzliche Informationen zum Gewindefräsen

Technical instructions,
basic informations about thread milling

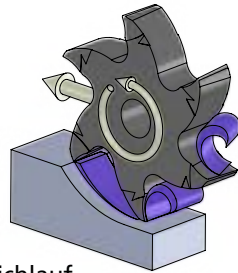

Gleichlauf
down-cut

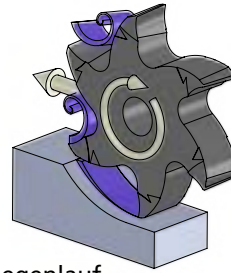

Gegenlauf
up-cut

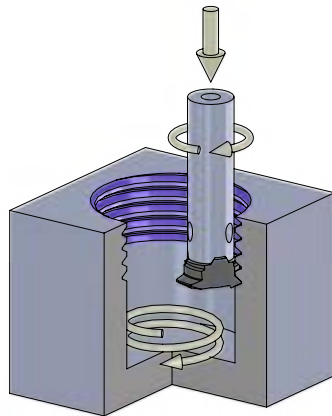

Rechtsgewinde (Gegenlauf)
Linksgewinde (Gleichlauf)*
RH-thread (up-cut)
LH-thread (down-cut)*

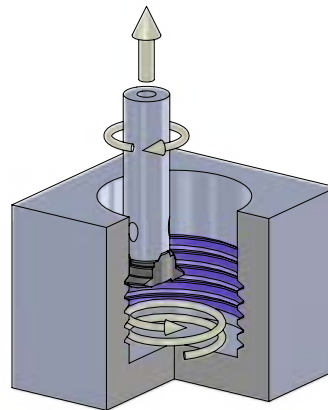

Rechtsgewinde (Gleichlauf)
Linksgewinde (Gegenlauf)*
RH-thread (down-cut)
LH-thread (up-cut)*

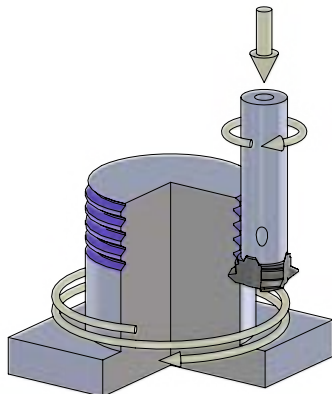

Rechtsgewinde (Gleichlauf)
Linksgewinde (Gegenlauf)*
RH-thread (down-cut)
LH-thread (up-cut)*

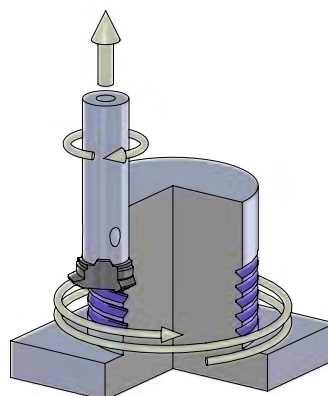

Rechtsgewinde (Gegenlauf)
Linksgewinde (Gleichlauf)*
RH-thread (up-cut)
LH-thread (down-cut)*

*Spiralbewegung axial gespiegelt
*spiral movement axially mirrored



SYSTEM 500

Nut-, Formzirkular- und
Trennfräsen

groove milling by
circular interpolation,
groove and slot milling

Technische Hinweise

Hartmetallsorten und Beschichtungen

Technical instructions,
carbide grades and coatings

K10F

Universell einsetzbares Feinkornhartmetall mit guter Verschleißfestigkeit. Unbeschichtet geeignet für Anwendungen mit niedrigen und mittleren Schnittgeschwindigkeiten, sowie die Bearbeitung von NE-Metallen.

All purpose micrograin carbide with good abrasion resistance. Uncoated for applications with low or medium cutting speeds and machining of non-ferrous materials.

P04C

Optimierte, sehr universell einsetzbare TIALN-Beschichtung mit hoher Temperaturbeständigkeit bei hoher Härte. Sehr gut geeignet auch für NE-Metalle.

Optimized TIALN coating - very universal with a high resistance to high temperature and hardness. Very suitable also for non-ferrous metals.

AL41F

Sehr universell einsetzbare TIALN-Beschichtung mit hoher Temperaturbeständigkeit bei hoher Härte. Sehr gut geeignet auch für NE-Metalle.

TIALN coating - very universal with a high resistance to high temperature and hardness. Very suitable also for non-ferrous metals.

CN45F

Universell einsetzbare PVD-TIN-Beschichtung. Diese Allround-Sorte ist für niedrige und mittlere Schnittgeschwindigkeiten mit Einschränkung bei NE-Metallen.

PVD-TIN coating - all purpose, all around grade is suitable for low and medium cutting speed with restrictions on non-ferrous materials.

P18C

Universell einsetzbare Hochleistungsschicht mit hoher Oxidationsbeständigkeit, Verschleißfestigkeit und Warmhärte.

Very universal high performance coating with high oxidation resistance, wear resistance and hot hardness resistance.

P18C-X

Universell einsetzbare Hochleistungsschicht mit hoher Oxidationsbeständigkeit, Verschleißfestigkeit und Warmhärte. Fräswendeschneidplatte mit Hochleistungsschneidkante, extra stabile Ausführung.

Very universal high performance coating with high oxidation resistance, wear resistance and hot hardness resistance. Indexable milling insert with high performance cutting edge extra strong design.

SYSTEM 500

Nut-, Formzirkular- und
Trennfräsen

groove milling by
circular interpolation,
groove and slot milling

Technische Hinweise

Hartmetallsorten und Beschichtungen

Technical instructions,
carbide grades and coatings

P07C

Beschichtung für die Bearbeitung von Titan, Edelstahl und Molybdän.

Coating to machine titanium, stainless steel and molybdenum.

XC2A

Beschichtung mit einer exzellenten Warmhärte, Oxidationsbeständigkeit und thermischen Isolationsfähigkeit. Ideal für Hartzerspannung >60HRC

Coating with excellent hot hardness, high oxidation resistance and thermal insulation capacity. Ideal for hard machining >60 HRC.

P03C

Beschichtung für die Bearbeitung von schwer zerspanbaren Materialien. Sehr gut auch für die Trockenbearbeitung geeignet.

Coating for materials which are difficult to machine. Perfect to use for dry machining.

PD2F

Beschichtung für den universellen Einsatz bei niedrigen und mittleren Schnittgeschwindigkeiten.

Coating for universal use with medium and low speed.

NEME

Beschichtung für die Bearbeitung von Aluminium, Al-Legierungen, NE-Metallen und Kompositwerkstoffen.

Coating for machining aluminium, Al alloys, non-ferrous metals and composite materials.



SYSTEM 500

Nut-, Formzirkular- und Trennfräsen

groove milling by circular interpolation, groove and slot milling

Technische Hinweise

Ermittlung der Schnittdaten

Technical instructions, evaluation of the cutting data

$$n = \frac{V_c * 1000}{d * \pi} \quad V_{eff} = f_z * z * n \quad f_z = h_m * \sqrt{\frac{d}{a_e}}$$

Fräsen Außenkontur
milling external

$$V_{prog} = \frac{V_{eff} * (D + d)}{D}$$

$$V_{eff} = \frac{D * V_{prog}}{(D + d)}$$

Fräsen Innenkontur
milling internal

$$V_{prog} = \frac{V_{eff} * (D - d)}{D}$$

$$V_{eff} = \frac{D * V_{prog}}{(D - d)}$$

Formel-Zeichen
formula characters

Bezeichnungen
specifications

Einheit
unit

a_e

Spantiefe radial
radial depth of cut

mm

d

Fräserdurchmesser
milling diameter

mm

D

Konturdurchmesser
contour diameter

mm

f_z

Vorschub pro Zahn
feed per tooth

mm

h_m

mittlere Spandicke
medium thickness of chip

mm

h_{max}

maximale Spandicke
maximum thickness of chip

mm

n

Spindeldrehzahl
revolutions

U / min

R

Radius Fräser
radius of cutter

mm

Nach Möglichkeit immer im Kreisbogen eintauchen.

Always plunge in a circular arc where possible.

SYSTEM 500

Nut-, Formzirkular- und
Trennfräsen

groove milling by
circular interpolation,
groove and slot milling

Technische Hinweise

Ermittlung der Schnittdaten

Technical instructions,
evaluation of the cutting data

$$z = \frac{\text{Fräswendeschneidplatten / *}}{\text{quantity of cutting inserts}} = \frac{\quad}{2}$$

$$n = \frac{V_c * 1000}{d * \pi}$$

$$V_f = f_z * z * n$$

$$f_z = h_m * \sqrt{\frac{d}{a_e}}$$

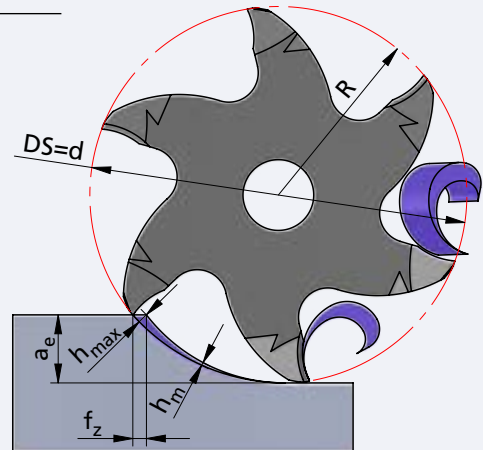

Formel-Zeichen
formula characters

Bezeichnungen
specifications

Einheit
unit

V_{eff}

effektive Vorschubgeschwindigkeit
(auf / an der Kontur)
feed rate of tool tip

mm / min

V_{prog}

programmierte Vorschubgeschwindigkeit
feed rate of tool center

mm / min

V_c

Schnittgeschwindigkeit
cutting speeds

m / min

V_f

Vorschubgeschwindigkeit
feed rate of tool center

mm / min

z

Schneidenzahl Fräser
number of cutting edges

Stk.
pcs.

*

Nur bei Typ 590 und 591 anwenden.

Use only for type 590 and 591.



SYSTEM 500

Nut-, Formzirkular- und Trennfräsen

groove milling by circular interpolation, groove and slot milling

Technische Hinweise

Schnittdatenempfehlung: metrisch

Technical instructions, speed and feed recommendation: metric

Schnittgeschwindigkeit: V_C (m/min)
Vorschub pro Zahn: fz (mm)

cutting speed: V_C (m/min)
feed per tooth: fz (mm)

Werkstoffgruppe material group		Zusammensetzung composition		(Zug-)Festigkeit tensile strength	
ISO	Beschreibung / description	Gefüge / structure	Wärmebehandlung / heat treatment	Psi / N/mm ² (Rm) / HB / HRC	
P	Unlegierter Stahl unalloyed steel	ca.lapp. 0,15 % C	geglüht / annealed	61000 Psi / 420 N/mm ² / 125 HB	
		ca.lapp. 0,45 % C	geglüht / annealed	93000 Psi / 640 N/mm ² / 190 HB	
		ca.lapp. 0,75 % C	vergütet / tempered	122000 Psi / 840 N/mm ² / 250 HB	
			geglüht / annealed	132000 Psi / 910 N/mm ² / 270 HB	
	Niedriglegierter Stahl low alloyed steel	vergütet / tempered	146500 Psi / 1010 N/mm ² / 300 HB		
		geglüht / annealed	88500 Psi / 610 N/mm ² / 180 HB		
		vergütet / tempered	135000 Psi / 930 N/mm ² / 275 HB		
		vergütet / tempered	146500 Psi / 1010 N/mm ² / 300 HB		
	Hochlegierter (Werkzeug)-Stahl highly alloyed steel	vergütet / tempered	174000 Psi / 1200 N/mm ² / 375 HB		
		geglüht / annealed	99000 Psi / 680 N/mm ² / 200 HB		
gehärtet & angelassen / hardened & tempered		160000 Psi / 1100 N/mm ² / 300 HB			
Nichtrostender Stahl stainless steel	gehärtet & angelassen / hardened & tempered	189000 Psi / 1300 N/mm ² / 400 HB			
	ferritisch, martensitisch / ferritic, martensitic	geglüht / annealed	99000 Psi / 680 N/mm ² / 200 HB		
M	Nichtrostender Stahl stainless steel	martensitisch / martensitic	vergütet / tempered	117500 Psi / 810 N/mm ² / 250 HB	
		austenitisch / austenitic	abgeschreckt / quenched	88500 Psi / 610 N/mm ² / 200 HB	
		austenitisch / austenitic	vergütet / tempered	300 HB	
K	Grauguss cast iron	austenitisch, ferritisch / ferritic, martensitic (Duplex)		113000 Psi / 780 N/mm ² / 230 HB	
		perlitisch, ferritisch / pearlitic, ferritic		51000 Psi / 350 N/mm ² / 180 HB	
	Gusseisen mit Kugelgraphit cast iron with nodular graphite	perlitisch (martensitisch) / pearlitic (martensitic)		72500 Psi / 500 N/mm ² / 260 HB	
		ferritisch / ferritic		72500 Psi / 500 N/mm ² / 160 HB	
Temperguss malleable iron	perlitisch / pearlitic		122500 Psi / 845 N/mm ² / 250 HB		
	ferritisch / ferritic		63800 Psi / 440 N/mm ² / 130 HB		
N	Aluminium - Knetlegierungen wrought aluminum alloys	nicht aushärtbar / uncurable		60 HB	
		aushärtbar / curable	ausgehärtet / cured	49000 Psi / 340 N/mm ² / 100 HB	
		≤ 12% Si, nicht aushärtbar / uncurable		36250 Psi / 250 N/mm ² / 75 HB	
	Aluminium - Gusslegierungen cast aluminum alloys	≤ 12% Si, aushärtbar / curable	ausgehärtet / cured	43500 Psi / 300 N/mm ² / 90 HB	
		> 12% Si, nicht aushärtbar / uncurable		63800 Psi / 440 N/mm ² / 130 HB	
	Kupfer und Kupferlegierungen (Bronze / Messing) copper and copper alloys (bronze / brass)	PB > 1 %, Automatenlegierungen / free cutting alloys		54500 Psi / 375 N/mm ² / 110 HB	
CuZn, CuSnZn			43500 Psi / 300 N/mm ² / 90 HB		
CuSn, bleifrei & Elektrolytisch / lead free & electrolytic			49000 Psi / 340 N/mm ² / 100 HB		
Magnesium & -Legierungen / Mg-alloys	Magnesium und -Legierungen / and -alloys		70 HB		
S	Warmfeste Legierungen heat-resistant alloys	Fe-Basis / Fe base	geglüht / annealed	99000 Psi / 680 N/mm ² / 200 HB	
			ausgehärtet / cured	137750 Psi / 950 N/mm ² / 280 HB	
		Ni- oder Co-Basis / Ni- or Co-Base	geglüht / annealed	122000 Psi / 840 N/mm ² / 250 HB	
			ausgehärtet / cured	171000 Psi / 1180 N/mm ² / 350 HB	
	Titanlegierungen titanium alloys	gegossen / cast		156600 Psi / 1080 N/mm ² / 320 HB	
		Reintitan / pure titanium		58000 Psi / 400 N/mm ²	
H	Gehärteter Stahl hardened steel	Alpha- + Beta-Legierungen / -alloys	ausgehärtet / cured	152250 Psi / 1050 N/mm ²	
		Beta-Legierungen / -alloys		203000 Psi / 1400 N/mm ² / 410 HB	
		gehärtet & angelassen / hardened & tempered		46-55 HRC	
O	Nichtmetallische Werkstoffe non-metallic materials	gehärtet & angelassen / hardened & tempered		56-60 HRC	
		gehärtet & angelassen / hardened & tempered		61-65 HRC	
O	Hartguss / chilled cast iron	gehärtet & angelassen / hardened & tempered		66-70 HRC	
		gegossen / cast		400 HB	
		gehärtet & angelassen / hardened & tempered		55 HRC	
		Gehärtetes Guss / hardened cast iron	Kunststoffe, duroplastisch / plastics, duroplastic		≤ 21750 Psi / ≤ 150 N/mm ²
			Kunststoffe, thermoplastisch / plastics, thermoplastic		≤ 14500 Psi / ≤ 100 N/mm ²
aramidfaserverstärkt / aramid fiber reinforced			≤ 145000 Psi / ≤ 1000 N/mm ²		
O	Nichtmetallische Werkstoffe non-metallic materials	glas/kohlefaserverstärkt / glas/carbon fiber reinforced		≤ 145000 Psi / ≤ 1000 N/mm ²	
		Graphit / graphite			

Richtige Schnittgeschwindigkeit ist in Abhängigkeit von Dimension und Anwendungssituation zu wählen.

The correct cutting speed must be selected depending on the dimension and application situation.

20 (10 - 50) bevorzugte Wahl / best choice
20 (10 - 50) bedingt möglich / conditionally possible

20 (10 - 50) empfohlener Startwert / recommended starting value (bevorzugter Einsatzbereich) / (preferred application area)

SYSTEM 500

Nut-, Formzirkular- und Trennfräsen

groove milling by circular interpolation, groove and slot milling

Technische Hinweise

Schnittdatenempfehlung:

Technical instructions, speed and feed recommendation: imperial

cutting speed (SFM):
feed per tooth:

V_C (feet/min)
fz (inch)

Werkstoffgruppe material group		Zusammensetzung composition		(Zug-)Festigkeit tensile strength
ISO	Beschreibung / description	Gefüge / structure	Wärmebehandlung / heat treatment	Psi / N/mm ² (Rm) / HB / HRC
P	Unlegierter Stahl unalloyed steel	ca.Japp. 0,15 % C	geglüht / annealed	61000 Psi / 420 N/mm ² / 125 HB
		ca.Japp. 0,45 % C	geglüht / annealed	93000 Psi / 640 N/mm ² / 190 HB
		ca.Japp. 0,75 % C	vergütet / tempered	122000 Psi / 840 N/mm ² / 250 HB
			geglüht / annealed	132000 Psi / 910 N/mm ² / 270 HB
	Niedriglegierter Stahl low alloyed steel	vergütet / tempered	146500 Psi / 1010 N/mm ² / 300 HB	
		geglüht / annealed	88500 Psi / 610 N/mm ² / 180 HB	
		vergütet / tempered	135000 Psi / 930 N/mm ² / 275 HB	
		vergütet / tempered	146500 Psi / 1010 N/mm ² / 300 HB	
	Hochlegierter (Werkzeug-)Stahl highly alloyed steel	vergütet / tempered	174000 Psi / 1200 N/mm ² / 375 HB	
		geglüht / annealed	99000 Psi / 680 N/mm ² / 200 HB	
gehärtet & angelassen / hardened & tempered		160000 Psi / 1100 N/mm ² / 300 HB		
Nichtrostender Stahl stainless steel	gehärtet & angelassen / hardened & tempered	189000 Psi / 1300 N/mm ² / 400 HB		
	ferritisch, martensitisch / ferritic, martensitic	geglüht / annealed	99000 Psi / 680 N/mm ² / 200 HB	
M	Nichtrostender Stahl stainless steel	martensitisch / martensitic	vergütet / tempered	117500 Psi / 810 N/mm ² / 250 HB
		austenitisch / austenitic	abgeschreckt / quenched	88500 Psi / 610 N/mm ² / 200 HB
		austenitisch / austenitic	vergütet / tempered	300 HB
K	Grauguss cast iron	austenitisch, ferritisch / ferritic, martensitic (Duplex)		113000 Psi / 780 N/mm ² / 230 HB
		perlitisch, ferritisch / pearlitic, ferritic		51000 Psi / 350 N/mm ² / 180 HB
	Gusseisen mit Kugelgraphit cast iron with nodular graphite	perlitisch (martensitisch) / pearlitic (martensitic)		72500 Psi / 500 N/mm ² / 260 HB
		ferritisch / ferritic		72500 Psi / 500 N/mm ² / 160 HB
Temperguss malleable iron	perlitisch / pearlitic		122500 Psi / 845 N/mm ² / 250 HB	
	ferritisch / ferritic		63800 Psi / 440 N/mm ² / 130 HB	
N	Aluminium - Knetlegierungen wrought aluminum alloys	nicht aushärtbar / uncurable		60 HB
		aushärtbar / curable	ausgehärtet / cured	49000 Psi / 340 N/mm ² / 100 HB
		≤ 12% Si, nicht aushärtbar / uncurable		36250 Psi / 250 N/mm ² / 75 HB
	Aluminium - Gusslegierungen cast aluminum alloys	≤ 12% Si, aushärtbar / curable	ausgehärtet / cured	43500 Psi / 300 N/mm ² / 90 HB
		> 12% Si, nicht aushärtbar / uncurable		63800 Psi / 440 N/mm ² / 130 HB
	Kupfer und Kupferlegierungen (Bronze / Messing) copper and copper alloys (bronze / brass)	PB > 1 %, Automatenlegierungen / free cutting alloys		54500 Psi / 375 N/mm ² / 110 HB
CuZn, CuSnZn			43500 Psi / 300 N/mm ² / 90 HB	
CuSn, bleifrei & Elektrolytisch / lead free & electrolytic			49000 Psi / 340 N/mm ² / 100 HB	
Magnesium - & Legierungen / Mg-alloys	Magnesium und -Legierungen / and -alloys		70 HB	
S	Warmfeste Legierungen heat-resistant alloys	Fe-Basis / Fe base	geglüht / annealed	99000 Psi / 680 N/mm ² / 200 HB
			ausgehärtet / cured	137750 Psi / 950 N/mm ² / 280 HB
		Ni- oder Co-Basis / Ni- or Co-Base	geglüht / annealed	122000 Psi / 840 N/mm ² / 250 HB
			ausgehärtet / cured	171000 Psi / 1180 N/mm ² / 350 HB
			gegossen / cast	156600 Psi / 1080 N/mm ² / 320 HB
	Titanlegierungen titanium alloys	Reintitan / pure titanium		58000 Psi / 400 N/mm ²
	Alpha- + Beta-Legierungen / -alloys	ausgehärtet / cured	152250 Psi / 1050 N/mm ²	
	Beta-Legierungen / -alloys		203000 Psi / 1400 N/mm ² / 410 HB	
H	Gehärteter Stahl hardened steel		gehärtet & angelassen / hardened & tempered	46-55 HRC
			gehärtet & angelassen / hardened & tempered	56-60 HRC
			gehärtet & angelassen / hardened & tempered	61-65 HRC
	Hartguss / chilled cast iron		gehärtet & angelassen / hardened & tempered	66-70 HRC
Gehärtetes Guss / hardened cast iron		gegossen / cast	400 HB	
		gehärtet & angelassen / hardened & tempered	55 HRC	
O	Nichtmetallische Werkstoffe non-metallic materials	Kunststoffe, duroplastisch / plastics, duroplastic		≤ 21750 Psi / ≤ 150 N/mm ²
		Kunststoffe, thermoplastisch / plastics, thermoplastic		≤ 14500 Psi / ≤ 100 N/mm ²
		aramidfaserverstärkt / aramid fiber reinforced		≤ 145000 Psi / ≤ 1000 N/mm ²
		glas/kohlefaserverstärkt / glas/carbon fiber reinforced		≤ 145000 Psi / ≤ 1000 N/mm ²
		Graphit / graphite		

The correct cutting speed must be selected depending on the dimension and application situation.

20 (10 - 50) best choice
20 (10 - 50) conditionally possible

20 (10 - 50)
recommended starting value (preferred application area)



duemmel.de



ROTALINE

D min. $\geq \varnothing 0.4$ mm

ROTALINE

Ausspindeln
ab Ø 0.4 mm

precision boring
starting at Ø 0.4 mm

Übersicht

summary



Allgemeine Beschreibung

general instructions

... 4

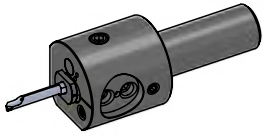

Klemmhalter und Reduzierhülsen

**toolholder and
reduction bushes**

**Maße
dimensions
[mm]**

**Seite
page**

ROTA-VAR0319

Feindrehwerkzeug und Reduzierhülsen
mit Innenkühlung und externer
digitaler Anzeigeeinheit

precision turning tool and reduction
bushes with internal coolant supply
and external digital display unit

D min. 0.4 – 18.4

... 6

ROTA-HSP0410

Feindrehwerkzeug und Reduzierhülsen
mit Innenkühlung und interner
digitaler Anzeigeeinheit

precision turning tool and reduction
bushes with internal coolant supply
and internal digital display unit

D min. 0.4 – 15.8

... 7

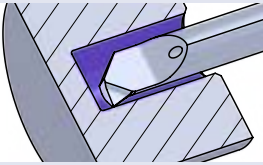

**Schneideinsätze
Ausspindeln**

**inserts
precision boring**

**Maße
dimensions
[mm]**

**Seite
page**

ROTA...RIK

Hartmetallausdrehchneiden
mit Innenkühlung

carbide mini boring insert
with internal coolant supply

D min. 0.4 – 13.0

... 8

ROTA...R

Hartmetallausdrehchneiden

carbide mini boring insert

D min. 0.4 – 13.0

... 10

**V...HM
RS08...
RS11...**

Hartmetallausdrehchneiden
mit Innenkühlung

carbide mini boring insert
with internal coolant supply

D min. 9.3 – 18.4

... 11

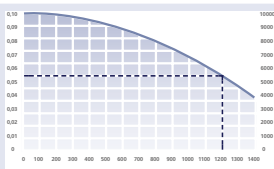

Technische Hinweise

Technical Instructions

**Seite
page**

Hartmetallsorten und Beschichtungen

carbide grades and coatings

... 12

Schnittdatenempfehlung

speed and feed recommendation

... 14

ROTALINE

Ausspindeln
ab \varnothing 0.4 mm

precision boring
starting at \varnothing 0.4 mm

Impressionen

impressions

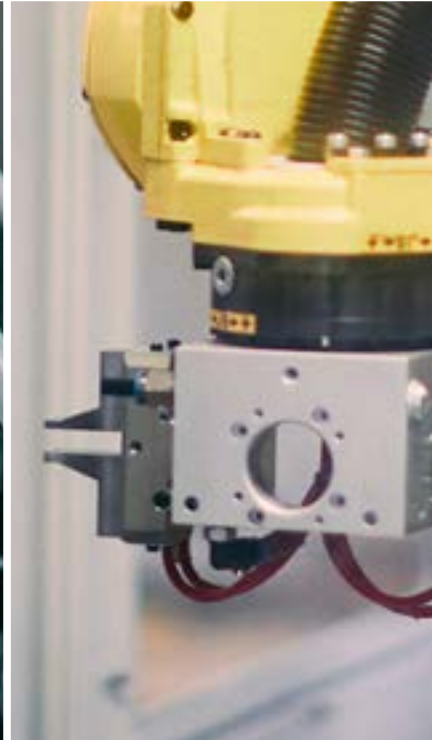

ROTALINE

Ausspindeln
ab \varnothing 0.4 mm

precision boring
starting at \varnothing 0.4 mm

Allgemeine Beschreibung

ROTA-VAR

general instructions
ROTA-VAR



- Einfachste Handhabung mit externer Digitalanzeige
- Zustellgenauigkeit 0.002 mm im Durchmesser
- 2.5 mm radiale Hubverstellung
- Stufenlos axial einstellbare Schneiden
- Automatisch definierte Schneidenlage
- Zylindrischer Schaft für flexible Anwendungen
- Innere Kühlschmierstoffzufuhr (max. 40 bar)
- Aufgrund geringer Baugröße (Körper- \varnothing = 32 mm) hervorragend geeignet zum Einsatz bei kleinen Platzverhältnissen
- **Nicht** im Hydrodehnspannfutter einsetzen!
- **Nicht** im Schrumpffutter einsetzen!
- Flexibles System - digital und analog einsetzbar
- Digitale Anzeigeeinheit kann mit mehreren Ausspindelköpfen verwendet werden.
- Digitale Anzeige umschaltbar mm / inch

- easiest handling with external digital display unit
- infeed accuracy 0.002 mm in diameter
- 2.5 mm radial stroke adjustment
- infinitely variable axially adjustable inserts
- automatically defined insert alignment
- cylindrical shank for flexible applications
- internal coolant supply (max. 40 bar)
- due to the small size (body \varnothing = 32 mm) outstanding suited for use with small space conditions
- **do not** use in the hydraulic expansion chuck!
- **do not** use in the shrink chuck!
- flexible system - can be used digitally and analogously
- digital display unit can be used with multiple boring heads.
- digital display switchable mm / inch

Maximal zulässige Drehzahlen
< \varnothing 6.0 max. 30.000 U/min
> \varnothing 6.0 <5x Schaft- \varnothing max. 30.000 U/min
> \varnothing 6.0 >5x Schaft- \varnothing max. 18.000 U/min

maximum permissible speeds
< \varnothing 6.0 max. 30.000 rpm
> \varnothing 6.0 <5x shank- \varnothing max. 30.000 rpm
> \varnothing 6.0 >5x shank- \varnothing max. 18.000 rpm

Gewicht / weight [kg]

ROTA-VAR0319 0.20

Ausdrehbereich / boring range [A]

ROTA-VAR0319 \varnothing 0.4 - \varnothing 18.4

ROTALINE

Ausspindeln
ab \varnothing 0.4 mm

precision boring
starting at \varnothing 0.4 mm

Allgemeine Beschreibung

ROTA-HSP

general instructions
ROTA-HSP



- Einfachste Handhabung mit interner Digitalanzeige
 - Zustellgenauigkeit 0.002 mm im Durchmesser
 - 1.2 mm radiale Hubverstellung
 - Stufenlos axial einstellbare Schneiden
 - Automatisch definierte Schneidenlage
 - Zylindrischer Schaft für flexible Anwendungen
 - Innere Kühlschmierstoffzufuhr (max. 40 bar)
 - Kompakte Baugröße (Körper- \varnothing = 40 mm)
hervorragend geeignet zum Einsatz auf kompakten
Maschinen ab Spindelgröße HSK40
 - **Nicht** im Hydrodehnspannfutter einsetzen!
 - **Nicht** im Schrumpffutter einsetzen!
 - Manuelle Feinwuchtung per Ausgleichsgewichte
 - Wasser und staubgeschützt gemäß IP65
- easiest handling with internal digital display unit
 - infeed accuracy 0.002 mm in diameter
 - 1.2 mm radial stroke adjustment
 - infinitely axially adjustable cutting edges
 - automatically defined cutting edge position
 - cylindrical shank for flexible applications
 - internal coolant supply (max. 40 bar)
 - compact size (body \varnothing = 40 mm)
outstanding for use on compact Machines from spindle
size HSK40
 - **do not** use in the hydraulic expansion chuck!
 - **do not** use in the shrink chuck!
 - manual fine balancing via balancing weight
 - water and dust proof according to IP65

Maximal zulässige Drehzahlen
< \varnothing 6.0 max. 35.000 U/min
> \varnothing 6.0 <5x Schaft- \varnothing max. 35.000 U/min
> \varnothing 6.0 >5x Schaft- \varnothing max. 25.000 U/min

maximum permissible speeds
< \varnothing 6.0 max. 35.000 rpm
> \varnothing 6.0 <5x shank- \varnothing max. 35.000 rpm
> \varnothing 6.0 >5x shank- \varnothing max. 25.000 rpm

Gewicht / weight [kg]

ROTA-HSP0410 0.44

Ausdrehbereich / boring range [A]

ROTA-HSP0410 \varnothing 0.4 - \varnothing 15.8



ROTALINE

Ausspindeln
ab $\varnothing 0.4$ mm

precision boring
starting at $\varnothing 0.4$ mm

ROTA-VAR0319

Feindrehwerkzeug und Reduzierhülsen
mit Innenkühlung und externer
digitaler Anzeigeeinheit

precision turning tool
and reduction bushes
with internal coolant supply
and external digital display unit

für Schneideinsätze
D min. 0.4 - 18.4 mm

for inserts
D min. 0.4 - 18.4 mm

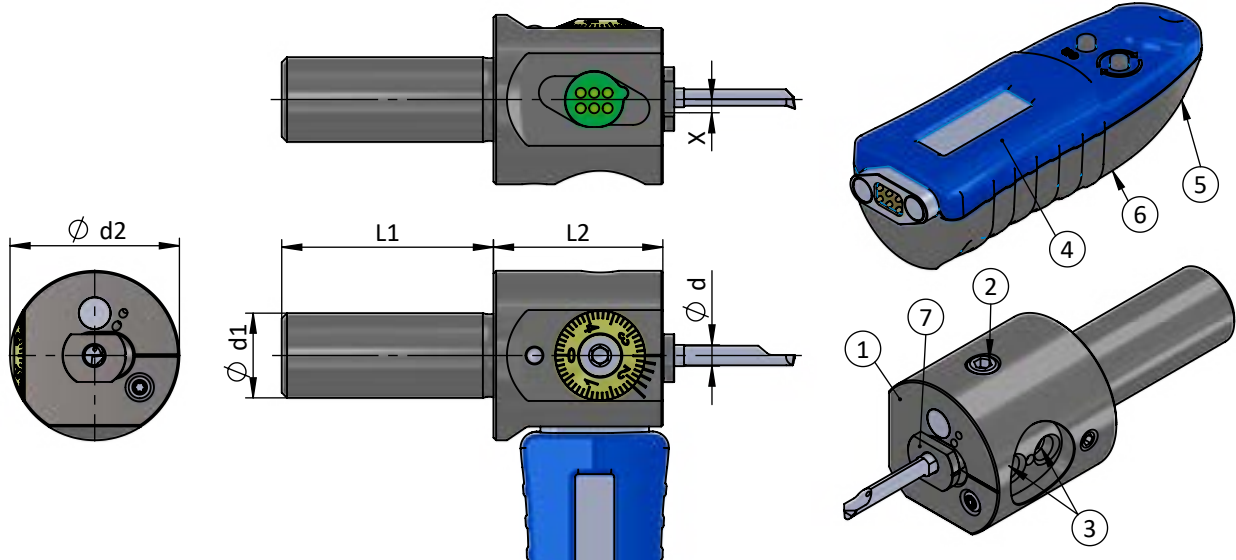

Klemmhalter für rechte
Schneideinsätze einsetzbar

X = Feinjustierung (Hub)

toolholder for right inserts usable

Abmessungen in mm

X = fine adjustment (stroke)

dimensions in mm



Bestellnummer part number	Position	Bezeichnung description	X	$\varnothing d$	$\varnothing d1$	$\varnothing d2$	L1	L2	Schraubenschlüssel wrench	Anzugs- drehmoment torque	$\varnothing d$ $\varnothing d h6$ Schneideinsatz insert
ROTA-VAR0319	1	Spindelkopf zum Innendrehen / precision boring tool for internal turning	2.5	8	16	32	40	32			8
VAR-M6/5	2	Hub-Klemmschraube / stroke clamping screw							DS SW30	4.0 Nm	
VAR-M6/8	3	Schneiden-Spannschraube / insert clamping screw							DS SW30	4.0 Nm	
VAR-DIGI	4	Digitale Anzeigeeinheit VAR / Digital display unit VAR									
VAR-PT22	5	VAR-DIGI-Gehäuseschraube / VAR-DIGI casing screw							T10F	1.2 Nm	
VAR-BAT *	6	Batterie AAA / battery AAA									
RB04-VAR				4							4
RB05-VAR	7	Reduzierhülse / reduction bush		5							5
RB06-VAR				6							6
RB07-VAR				7							7

Reduzierhülsen und Anzeigeeinheit müssen
separat bestellt werden!

* Batterie ist im Lieferumfang enthalten.
Battery is included in the scope of delivery.

Reduction bushes and display unit must be
ordered separately!

Bestellbeispiel:
ROTA-VAR0319 + RB04-VAR + VAR-DIGI

order-example:
ROTA-VAR0319 + RB04-VAR + VAR-DIGI

ROTALINE

Ausspindeln
ab \varnothing 0.4 mm

precision boring
starting at \varnothing 0.4 mm

ROTA-HSP0410

Feindrehwerkzeug und Reduzierhülsen
mit Innenkühlung und interner
digitaler Anzegeeinheit

precision turning tool
and reduction bushes
with internal coolant supply
and internal digital display unit

für Schneideinsätze
D min. 0.4 - 15.8 mm

for inserts
D min. 0.4 - 15.8 mm

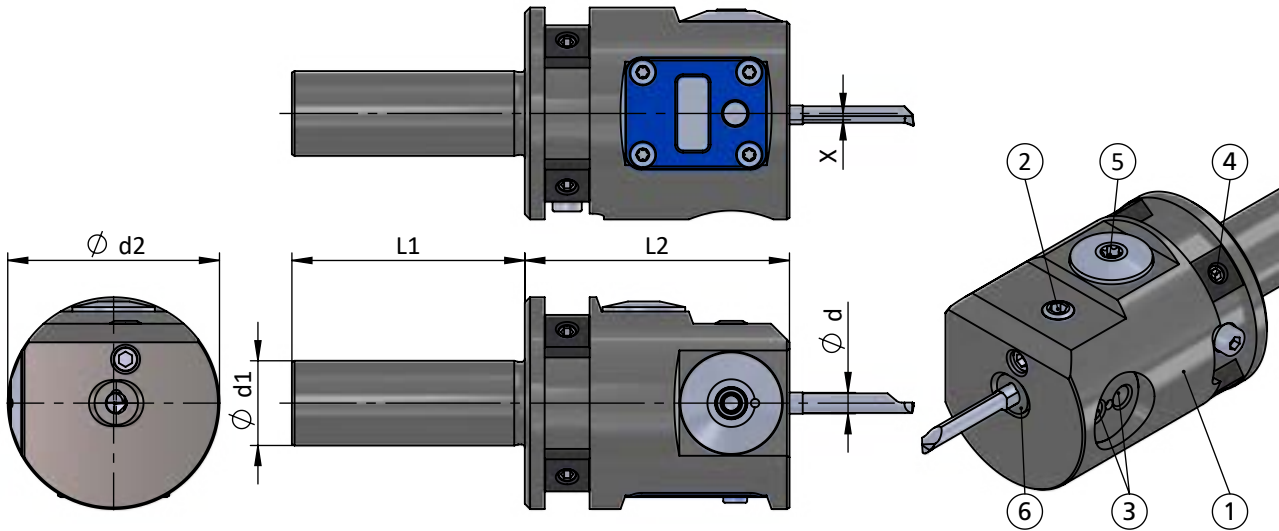

Klemmhalter für rechte
Schneideinsätze einsetzbar

X = Feinjustierung (Hub)

toolholder for right inserts usable



Abmessungen in mm

X = fine adjustment (stroke)

dimensions in mm

Bestellnummer part number	Position	Bezeichnung description	X	\varnothing d	\varnothing d1	\varnothing d2	L1	L2	Schraubenschlüssel wrench	Anzugs- drehmoment torque	Schneideinsatz insert	
											\varnothing d	\varnothing d h6
ROTA-HSP0410	1	Spindelkopf zum Innendrehen / precision boring tool for internal turning	1.2	8	16	40	44	50				8
ROTA-M6	2	Hub-Klemmschraube / stroke clamping screw							DS SW30	4.0 Nm		
ROTA-M5	3	Schneiden-Spannschraube / insert clamping screw							DS SW25	3.0 Nm		
ROTA-M4	4	Feinwucht-Spannschraube / balancing clamping screw							DS SW20	2.5 Nm		
ROTA-DCK	5	Batteriefachdeckel / battery compartment cover							T20F	5.0 Nm		
ROTA-DIC		Dichtung für Deckel / seal for cover										
ROTA-BAT*		Batterie / battery										
RB04-ROTA				4								4
RB05-ROTA	6	Reduzierhülse / reduction bush		5								5
RB06-ROTA				6								6
RB07-ROTA				7					without internal coolant supply			7

Reduzierhülsen müssen separat bestellt werden!

* Batterie ist im Lieferumfang enthalten.
Battery is included in the scope of delivery.

Reduction bushes must be ordered separately!

Bestellbeispiel:
ROTA-HSP0410+ RB04-ROTA

order-example:
ROTA-HSP0410+ RB04-ROTA

ROTALINE

Ausspindeln
ab Ø 0.4 mm

precision boring
starting at Ø 0.4 mm

ROTA...RIK

Hartmetallausdreh schneiden
mit Innenkühlung

D min. 0.4 - 10.4/13.0 mm

carbide mini boring insert
with internal coolant supply

D min. 0.4 - 10.4/13.0 mm

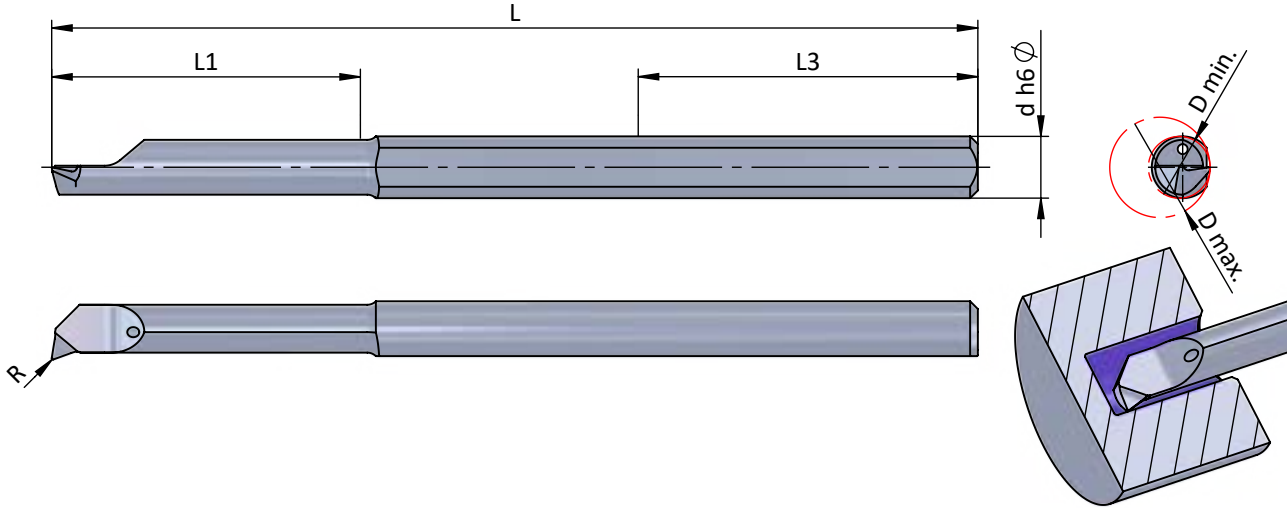

Rechts (R): wie gezeichnet

righthand (R): as shown

Abmessungen in mm

dimensions in mm



Bestellnummer part number	D min.	D max. * D max. = D min. + 2 * X	L1	R	L	L3	Mindest- einspannlänge min. clamping length	Ø d h6	P04C	XC2A	Feindrehwerkzeug precision turning tool		Reduzierhülse reduction bush
											ROTA-VAR0319 ROTA-HSP0410	RB04-VAR RB04-ROTA	
ROTA04-020RIK	0.4		2.0	0.03	45.0	20	4.0	●	●				
ROTA06-030RIK	0.6		3.0	0.04	45.0	20	4.0	●	●				
ROTA08-040RIK	0.8		4.0	0.04	45.0	20	4.0	●	●				
ROTA10-050RIK	1.0		5.0	0.05	45.0	20	4.0	●	●				
ROTA15-075RIK	1.5		7.5	0.05	47.5	20	4.0	●	●				
ROTA20-070RIK	2.0		7.0	0.05	31.0	20	4.0	●	●				
ROTA20-100RIK	2.0		10.0	0.05	53.0	20	4.0	●	●				
ROTA25-125RIK	2.5		12.5	0.05	53.0	20	4.0	●	●				
ROTA30-105RIK	3.0		10.5	0.07	34.5	20	4.0	●	●				
ROTA30-150RIK	3.0		15.0	0.07	53.0	20	4.0	●	●				
ROTA35-175RIK	3.5		17.5	0.08	53.0	20	4.0	●	●				
ROTA40-140RIK	4.0		14.0	0.08	38.0	20	4.0	●	●				
ROTA40-200RIK	4.0		20.0	0.08	60.0	20	4.0	●	●				
↳ ...													

Weitere HM Sorten können Sie in der Sortenübersicht im Kapitel "Technische Hinweise" und der Preisliste finden.

*
"X" ist abhängig vom gewählten Feindrehwerkzeug
"X" depends on the selected precision turning tool
ROTA-VAR0319: X = 2.5
ROTA-HSP0410: X = 1.2

More carbide grades you can find in the grades summary in the chapter "technical instructions" and in the price list.

order-example:
righthand version and grade
ROTA04-020RIK/P04C

Bestellbeispiel:
für rechte Ausführung und Sorte
ROTA04-020RIK/P04C

ROTALINE

Ausspindeln
ab \varnothing 0.4 mm

precision boring
starting at \varnothing 0.4 mm

ROTA...RIK

Hartmetallausdrehmaschinen
mit Innenkühlung

carbide mini boring insert
with internal coolant supply

D min. 0.4 - 10.4/13.0 mm

D min. 0.4 - 10.4/13.0 mm

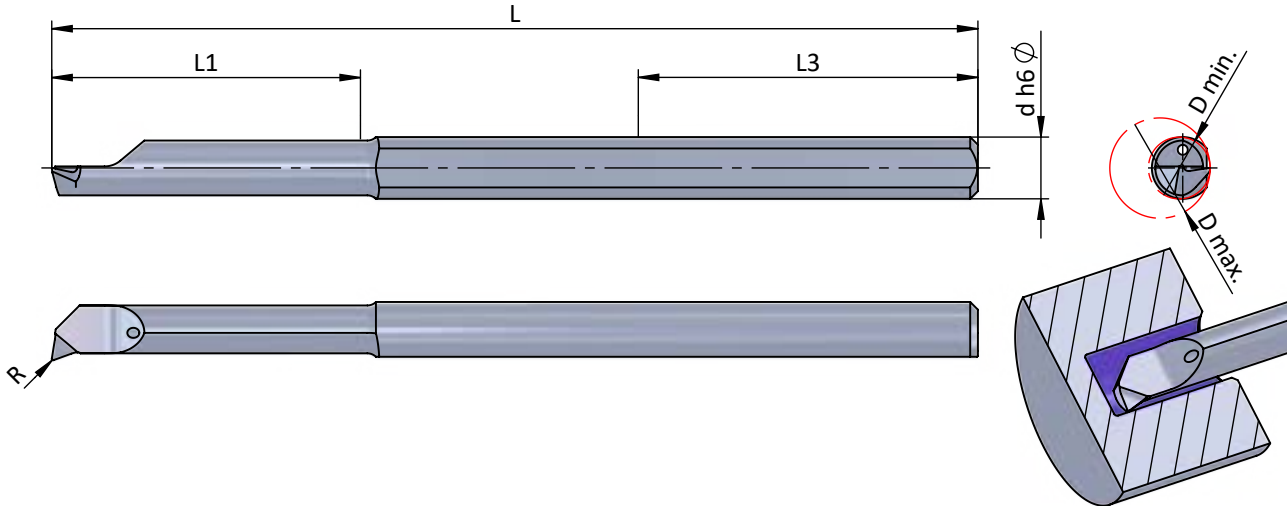

Rechts (R): wie gezeichnet

righthand (R): as shown

Abmessungen in mm

dimensions in mm



Bestellnummer part number	D min.	D max. *	L1	R	L	L3	Mindest- einspannlänge min. clamping length	\varnothing d h6	P04C	XC2A	Feindrehwerkzeug precision turning tool	
											Feindrehwerkzeug precision turning tool	Reduzierhülse reduction bush
ROTA50-175RIK	5.0	X	17.5	0.10	41.5	20	5.0	●	●	ROTA-VAR0319 ROTA-HSP0410	RB05-VAR RB05-ROTA	
ROTA50-250RIK	5.0	+ 2 * X	22.0	0.10	66.0	20	5.0	●	●		RB06-VAR RB06-ROTA	
ROTA60-210RIK	6.0	D min. = D	21.0	0.10	45.0	20	6.0	●	●		RB07-VAR RB07-ROTA	
ROTA60-320RIK	6.0	D max. = D	32.0	0.10	66.0	20	6.0	●	●			
ROTA70-405RIK	7.0		40.5	0.12	66.0	20	7.0	●	●			
ROTA80-505RIK	8.0		50.5	0.12	80.0	20	8.0	●	●			

Weitere HM Sorten können Sie in der Sortenübersicht im Kapitel "Technische Hinweise" und der Preisliste finden.

Bestellbeispiel:
für rechte Ausführung und Sorte
ROTA04-020RIK/P04C

*
"X" ist abhängig vom gewählten
Feindrehwerkzeug
"X" depends on the selected
precision turning tool
ROTA-VAR0319: X = 2.5
ROTA-HSP0410: X = 1.2

More carbide grades you can find in the grades summary in the chapter "technical instructions" and in the price list.

order-example:
righthand version and grade
ROTA04-020RIK/P04C

ROTALINE

Ausspindeln
ab Ø 0.4 mm

precision boring
starting at Ø 0.4 mm

ROTA...R

Hartmetallausdreh schneiden

D min. 0.4 - 10.4/13.0 mm

carbide mini boring insert

D min. 0.4 - 10.4/13.0 mm

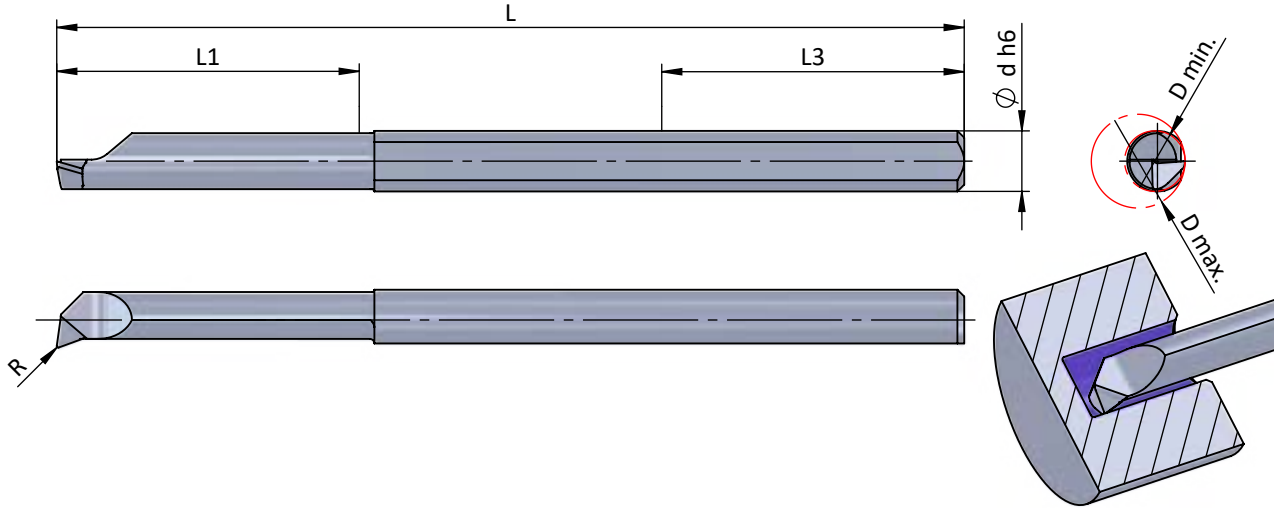

Rechts (R): wie gezeichnet

righthand (R): as shown

Abmessungen in mm

dimensions in mm

Best. Nummer part number	D min.	D max. *	L1	R	L	L3	Mindest- einspannlänge min. clamping length	Ø d h6	AL41F	XC2A	Feindrehwerkzeug precision turning tool	Reduzierhülse reduction bush
ROTA04-020R	0.4	D max. = D min. + 2 * X	2.0	0.03	42.0	20	4.0	4.0	●		ROTA-VAR0319 ROTA-HSP0410	RB04-VAR RB04-ROTA
ROTA06-030R	0.6		3.0	0.04	43.0	20	4.0	4.0	●			
ROTA08-040R	0.8		4.0	0.04	44.0	20	4.0	4.0	●			
ROTA10-050R	1.0		5.0	0.05	45.0	20	4.0	4.0	●			
ROTA15-075R	1.5		7.5	0.05	47.5	20	4.0	4.0	●			
ROTA20-100R	2.0		10.0	0.05	50.0	20	4.0	4.0	●	●		
ROTA25-125R	2.5		12.5	0.05	52.5	20	4.0	4.0	●	●		
ROTA28-140R	2.8		14.0	0.07	54.0	20	4.0	4.0	●	●		
ROTA35-180R	3.5		18.0	0.10	58.0	20	4.0	4.0	●	●		
ROTA40-200R	4.0		20.0	0.10	60.0	20	4.0	4.0	●	●		
ROTA50-255R	5.0		25.5	0.12	66.0	20	5.0	5.0	●	●		
ROTA60-320R	6.0		32.0	0.15	75.0	20	6.0	6.0	●	●		
ROTA70-405R	7.0		40.5	0.20	82.0	20	7.0	7.0	●	●		
ROTA80-505R	8.0		50.5	0.20	92.0	20	8.0	8.0	●	●		

Weitere HM Sorten können Sie in der Sortenübersicht im Kapitel "Technische Hinweise" und der Preisliste finden.

*
"X" ist abhängig vom gewählten Feindrehwerkzeug
"X" depends on the selected precision turning tool
ROTA-VAR0319: X = 2.5
ROTA-HSP0410: X = 1.2

More carbide grades you can find in the grades summary in the chapter "technical instructions" and in the price list.

order-example:
righthand version and grade
ROTA04-020R/AL41F

Bestellbeispiel:
für rechte Ausführung und Sorte
ROTA04-020R/AL41F

ROTALINE

Ausspindeln
ab Ø 0.4 mm

precision boring
starting at Ø 0.4 mm

V...HM / RS08... / RS11...

Hartmetallausdrehchneiden
mit Innenkühlung

carbide mini boring insert
with internal coolant supply

D min. 9.3 - 15.8/18.4 mm

D min. 9.3 - 15.8/18.4 mm

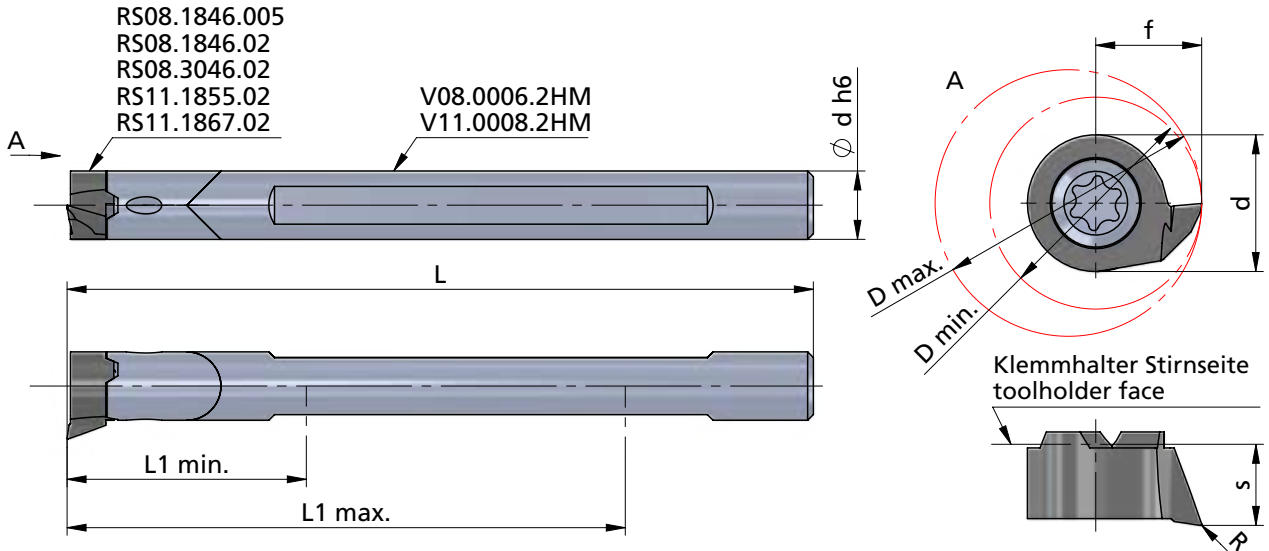

Rechts (R): wie gezeichnet

Achtung: Schneide muss in Richtung der Spannschrauben zeigen!

righthand (R): as shown

Abmessungen in mm

Attention: cutting edge has to face towards the clamp screws!

dimensions in mm

**



Bestellnummer part number	D min.	D max. *	L1 min.	L1 max.	L	Ø d h6	Spannschraube screw	Schraubenschlüssel wrench	Anzugs- drehmoment torque	Reduzierhülse / reduction bush	Feindrehwerkzeug precision turning tool	Schneideinsatz insert
V08.0006.2HM without through coolant	9.3		21	49	65	6	A.SPS016	T8F-P	1.2 Nm	RB06-VAR + ROTA-VAR0319 RB06-ROTA + ROTA-HSP0410		RS08...
** V11.0008.2HM	11		35	63	79	8	A.SPS021	T10F-P	3.5 Nm	- ROTA-VAR0319 - ROTA-HSP0410		RS11...
Bestellnummer part number	D min.		R	f	s	d						Klemmhalter toolholder
RS08.1846.005	9.3	D max. = D min. + 2 * X	0.05	4.65	3.5	6						
RS08.1846.02	9.3		0.2	4.65	3.5	6						V08.0006.2HM
RS08.3046.02	9.3		0.2	4.65	3.5	6						
RS11.1855.02	11.0		0.2	5.5	4.2	8						
RS11.1867.02	13.4		0.2	6.7	4.2	8						V11.0008.2HM

Weitere HM Sorten können Sie in der Sortenübersicht im Kapitel "Technische Hinweise" und der Preisliste finden.

Bestellbeispiel:
für rechte Ausführung und Sorte
RS08.1846.02/AL41F

*
"X" ist abhängig vom gewählten Feindrehwerkzeug
"X" depends on the selected precision turning tool
ROTA-VAR0319: X = 2.5
ROTA-HSP0410: X = 1.2

More carbide grades you can find in the grades summary in the chapter "technical instructions" and in the price list.

order-example:
righthand version and grade
RS08.1846.02/AL41F

ROTALINE

Ausspindeln
ab \varnothing 0.4 mm

precision boring
starting at \varnothing 0.4 mm

Technische Hinweise

Hartmetallsorten und Beschichtungen

Technical instructions,
carbide grades and coatings

K10F

Universell einsetzbares Feinkornhartmetall mit guter Verschleißfestigkeit. Unbeschichtet geeignet für Anwendungen mit niedrigen und mittleren Schnittgeschwindigkeiten, sowie die Bearbeitung von NE-Metallen.

All purpose micrograin carbide with good abrasion resistance. Uncoated for applications with low or medium cutting speeds and machining of non-ferrous materials.

P04C

Optimierte, sehr universell einsetzbare TIALN-Beschichtung mit hoher Temperaturbeständigkeit bei hoher Härte. Sehr gut geeignet auch für NE-Metalle.

Optimized TIALN coating - very universal with a high resistance to high temperature and hardness. Very suitable also for non-ferrous metals.

AL41F

Sehr universell einsetzbare TIALN-Beschichtung mit hoher Temperaturbeständigkeit bei hoher Härte. Sehr gut geeignet auch für NE-Metalle.

TIALN coating - very universal with a high resistance to high temperature and hardness. Very suitable also for non-ferrous metals.

CN45F

Universell einsetzbare PVD-TIN-Beschichtung. Diese Allround-Sorte ist für niedrige und mittlere Schnittgeschwindigkeiten mit Einschränkung bei NE-Metallen.

PVD-TIN coating - all purpose, all around grade is suitable for low and medium cutting speed with restrictions on non-ferrous materials.

P18C

Universell einsetzbare Hochleistungsschicht mit hoher Oxidationsbeständigkeit, Verschleißfestigkeit und Warmhärte.

Very universal high performance coating with high oxidation resistance, wear resistance and hot hardness resistance.

P07C

Beschichtung für die Bearbeitung von Titan, Edelstahl und Molybdän.

Coating to machine titanium, stainless steel and molybdenum.

ROTALINE

Ausspindeln
ab \varnothing 0.4 mm

precision boring
starting at \varnothing 0.4 mm

Technische Hinweise

Hartmetallsorten und Beschichtungen

Technical instructions,
carbide grades and coatings

XC2A

Beschichtung mit einer exzellenten Warmhärte, Oxidationsbeständigkeit und thermischen Isolationsfähigkeit. Ideal für Hartzerspanung >60HRC

Coating with excellent hot hardness, high oxidation resistance and thermal insulation capacity. Ideal for hard machining >60 HRC.

P03C

Beschichtung für die Bearbeitung von schwer zerspanbaren Materialien. Sehr gut auch für die Trockenbearbeitung geeignet.

Coating for materials which are difficult to machine. Perfect to use for dry machining.

PD2F

Beschichtung für den universellen Einsatz bei niedrigen und mittleren Schnittgeschwindigkeiten.

Coating for universal use with medium and low speed.

NEME

Beschichtung für die Bearbeitung von Aluminium, Al-Legierungen, NE-Metallen und Kompositwerkstoffen.

Coating for machining aluminium, Al alloys, non-ferrous metals and composite materials.



ROTALINE

Ausspindeln
ab Ø 0.4 mm

precision boring
starting at Ø 0.4 mm

Technische Hinweise

Schnittdatenempfehlung:
metrisch

Schnittgeschwindigkeit: V_C (m/min)
Vorschub: f (mm/U)

Technical instructions,
speed and feed recommendation:
metric

cutting speed: V_C (m/min)
feed: f (mm/rev)

Werkstoffgruppe material group		Zusammensetzung composition		(Zug-)Festigkeit tensile strength		
ISO	Beschreibung / description	Gefüge / structure	Wärmebehandlung / heat treatment	Psi / N/mm ² (Rm) / HB / HRC		
P	Unlegierter Stahl unalloyed steel	ca.Japp. 0,15 % C	geglüht / annealed	61000 Psi / 420 N/mm ² / 125 HB		
		ca.Japp. 0,45 % C	geglüht / annealed	93000 Psi / 640 N/mm ² / 190 HB		
			vergütet / tempered	122000 Psi / 840 N/mm ² / 250 HB		
		ca.Japp. 0,75 % C	geglüht / annealed	132000 Psi / 910 N/mm ² / 270 HB		
	Niedriglegierter Stahl low alloyed steel		vergütet / tempered	146500 Psi / 1010 N/mm ² / 300 HB		
			geglüht / annealed	88500 Psi / 610 N/mm ² / 180 HB		
			vergütet / tempered	135000 Psi / 930 N/mm ² / 275 HB		
			vergütet / tempered	146500 Psi / 1010 N/mm ² / 300 HB		
	Hochlegierter (Werkzeug)-Stahl highly alloyed steel			vergütet / tempered	174000 Psi / 1200 N/mm ² / 375 HB	
				geglüht / annealed	99000 Psi / 680 N/mm ² / 200 HB	
		gehärtet & angelassen / hardened & tempered	160000 Psi / 1100 N/mm ² / 300 HB			
Nichtrostender Stahl stainless steel		gehärtet & angelassen / hardened & tempered	189000 Psi / 1300 N/mm ² / 400 HB			
		ferritisch, martensitisch / ferritic, martensitic	geglüht / annealed	99000 Psi / 680 N/mm ² / 200 HB		
M	Nichtrostender Stahl stainless steel		martensitisch / martensitic	vergütet / tempered	117500 Psi / 810 N/mm ² / 250 HB	
			austenitisch / austenitic	abgeschreckt / quenched	88500 Psi / 610 N/mm ² / 200 HB	
			austenitisch / austenitic	vergütet / tempered	300 HB	
K	Grauguss cast iron		austenitisch, ferritisch / ferritic, martensitic (Duplex)	113000 Psi / 780 N/mm ² / 230 HB		
			perlitisch, ferritisch / pearlitic, ferritic	51000 Psi / 350 N/mm ² / 180 HB		
			perlitisch (martensitisch) / pearlitic (martensitic)	72500 Psi / 500 N/mm ² / 260 HB		
K	Gusseisen mit Kugelgraphit cast iron with nodular graphite		ferritisch / ferritic	72500 Psi / 500 N/mm ² / 160 HB		
			perlitisch / pearlitic	122500 Psi / 845 N/mm ² / 250 HB		
			ferritisch / ferritic	63800 Psi / 440 N/mm ² / 130 HB		
N	Aluminium - Knetlegierungen wrought aluminum alloys		perlitisch / pearlitic	113000 Psi / 780 N/mm ² / 230 HB		
			nicht aushärtbar / uncurable	60 HB		
			aushärtbar / curable	ausgehärtet / cured	49000 Psi / 340 N/mm ² / 100 HB	
N	Aluminium - Gusslegierungen cast aluminum alloys		≤ 12% Si, nicht aushärtbar / uncurable	36250 Psi / 250 N/mm ² / 75 HB		
			≤ 12% Si, aushärtbar / curable	ausgehärtet / cured	43500 Psi / 300 N/mm ² / 90 HB	
			> 12% Si, nicht aushärtbar / uncurable	ausgehärtet / cured	63800 Psi / 440 N/mm ² / 130 HB	
			PB > 1 %, Automatenlegierungen / free cutting alloys	54500 Psi / 375 N/mm ² / 110 HB		
N	Kupfer und Kupferlegierungen (Bronze / Messing) copper and copper alloys (bronze / brass)		CuZn, CuSnZn	43500 Psi / 300 N/mm ² / 90 HB		
			CuSn, bleifrei & Elektrolytisch / lead free & electrolytic	49000 Psi / 340 N/mm ² / 100 HB		
S	Magnesium &-Legierungen/Mg-alloys		Magnesium und -Legierungen / and -alloys	70 HB		
		Warmfeste Legierungen heat-resistant alloys		Fe-Basis / Fe base	geglüht / annealed	99000 Psi / 680 N/mm ² / 200 HB
					ausgehärtet / cured	137750 Psi / 950 N/mm ² / 280 HB
				Ni- oder Co-Basis / Ni- or Co-Base	geglüht / annealed	122000 Psi / 840 N/mm ² / 250 HB
					ausgehärtet / cured	171000 Psi / 1180 N/mm ² / 350 HB
				gegossen / cast	156600 Psi / 1080 N/mm ² / 320 HB	
	S	Titanlegierungen titanium alloys		Reintitan / pure titanium	58000 Psi / 400 N/mm ²	
				Alpha- + Beta-Legierungen / -alloys	ausgehärtet / cured	152250 Psi / 1050 N/mm ²
				Beta-Legierungen / -alloys		203000 Psi / 1400 N/mm ² / 410 HB
	H	Gehärteter Stahl hardened steel		gehärtet & angelassen / hardened & tempered	46-55 HRC	
			gehärtet & angelassen / hardened & tempered	56-60 HRC		
			gehärtet & angelassen / hardened & tempered	61-65 HRC		
			gehärtet & angelassen / hardened & tempered	66-70 HRC		
H	Hartguss / chilled cast iron		gegossen / cast	400 HB		
	Gehärtetes Guss / hardened cast iron		gehärtet & angelassen / hardened & tempered	55 HRC		
O	Nichtmetallische Werkstoffe non-metallic materials		Kunststoffe, duroplastisch / plastics, duroplastic	≤ 21750 Psi / ≤ 150 N/mm ²		
			Kunststoffe, thermoplastisch / plastics, thermoplastic	≤ 14500 Psi / ≤ 100 N/mm ²		
			aramidfaserverstärkt / aramid fiber reinforced	≤ 145000 Psi / ≤ 1000 N/mm ²		
			glas/kohlefaserverstärkt / glas/carbon fiber reinforced	≤ 145000 Psi / ≤ 1000 N/mm ²		
			Graphit / graphite			



Richtige Schnittgeschwindigkeit ist in Abhängigkeit von Dimension und Anwendungssituation zu wählen.

The correct cutting speed must be selected depending on the dimension and application situation.

20 (10 - 50) bevorzugte Wahl / best choice
20 (10 - 50) bedingt möglich / conditionally possible

20 (10 - 50) empfohlener Startwert recommended starting value (bevorzugter Einsatzbereich) (preferred application area)

Vorschub: feed f: [mm/U] [mm/rev]

Ausspindeln ≤ Ø 3mm: 0.01 - 0.06 mm/U
precision boring ≤ Ø 3mm: 0.01 - 0.06 mm/rev

Ausspindeln > Ø 3mm: 0.02 - 0.1 mm/U
precision boring > Ø 3mm: 0.02 - 0.1 mm/rev

ROTALINE

Ausspindeln
ab Ø 0.4 mm

precision boring
starting at Ø 0.4 mm

Technische Hinweise

Schnittdatenempfehlung:
metrisch

Technical instructions,
speed and feed recommendation:
metric

Schnittgeschwindigkeit: V_C (m/min)
Vorschub: f (mm/U)

cutting speed: V_C (m/min)
feed: f (mm/rev)

beispielhafte Werkstoffe exemplary materials				V_C Start (min. - max.)					
DIN	DIN-Code	DIN	DIN-Code	P04C / AL41F [m/min]	XC2A [m/min]				
1.0401	C15	1.1141	Ck 15	90 (40 - 180)	90 (40 - 180)				
1.1191	C45E	1.0718	9 SMnPb 28	70 (30 - 150)	70 (30 - 150)				
1.1191	C45E	1.0535	C 55	50 (20 - 120)	50 (20 - 120)				
1.1223	C60R	1.0535	C 55	50 (20 - 120)	50 (20 - 120)				
1.1223	C60R	1.0727	45 S 20	50 (20 - 100)	50 (20 - 100)				
1.7131	16 MnCr 5	1.6587	17 CrNiMo6	50 (20 - 120)	50 (20 - 120)				
1.7131	16 MnCr 5	1.6587	17 CrNiMo6	50 (20 - 100)	50 (20 - 100)				
1.7225	42 CrMo 4	1.3505	100Cr6	40 (20 - 90)	40 (20 - 90)				
1.7225	42 CrMo 4	1.3505	100Cr6	40 (20 - 80)	40 (20 - 80)				
1.4021	X20Cr13	1.4034	X46Cr13	40 (20 - 80)	40 (20 - 80)				
1.2343	X 38 CrMoV 5 1	1.4034	X46Cr13	30 (10 - 70)	30 (10 - 70)				
1.2343	X 38 CrMoV 5 1	1.4034	X46Cr13	20 (10 - 50)	20 (10 - 50)				
1.4016	X 6 Cr 17	1.2316	X36 CrMo 16	50 (20 - 100)	50 (20 - 100)				
1.4112	X90CrMoV18	1.2316	X36 CrMo 16	40 (20 - 90)	40 (20 - 90)				
1.4301	X 5 CrNi 18 10	1.4571	X2CrNiMo17-12-2	50 (20 - 120)	50 (20 - 120)				
1.4841	X15CrNiSi25-21	1.4539	X1NiCrMoCu25-20-5	40 (20 - 90)	40 (20 - 90)				
1.4462	X2CrNiMoN22-5-3	1.4501	X2CrNiMoCuWN25-7-4	40 (20 - 80)	40 (20 - 80)				
0.6010	GG-10	0.6025	GG-25	70 (30 - 150)	70 (30 - 150)				
0.6030	GG-30	0.6045	GG-45	50 (20 - 110)	50 (20 - 110)				
0.7040	GGG-40	0.7060	GGG-60	50 (20 - 100)	50 (20 - 100)				
0.7070	GGG-70	0.7080	GGG-80	40 (20 - 80)	40 (20 - 80)				
0.8035	GTW-35-04	0.8045	GTW-45	70 (30 - 150)	70 (30 - 150)				
0.8165	GTS-65-02	0.8170	GTS-70-02	60 (30 - 130)	60 (30 - 130)				
3.0255	Al99,5	3.3315	AlMg 1	250 (70 - 610)	250 (70 - 610)				
3.1355	AlCuMg2	3.2315	AlMgSi1	240 (70 - 580)	240 (70 - 580)				
3.2581	G-AlSi12	3.2163	G-AlSi9Cu3	200 (60 - 490)	200 (60 - 490)				
3.2134	G-AlSi5Cu1Mg	3.2373	G-AlSi9Mg	180 (50 - 430)	180 (50 - 430)				
-	G-AlSi17Cu4Mg (Silafont-90)	-	G-AlSi18CuNiMg (Silafont-92)	110 (30 - 260)	110 (30 - 260)				
2.0380	CuZn39Pb2 (Ms58)	2.0410	CuZn44Pb2	180 (50 - 440)	180 (50 - 440)				
2.0331	CuZn15	2.4070	CuZn28Sn1As	150 (40 - 370)	150 (40 - 370)				
2.0060	E-Cu57	2.0590	CuZn40Fe	130 (40 - 320)	130 (40 - 320)				
3.5612	MgAl6Zn	3.5312	MgAl3Zn	130 (40 - 320)	130 (40 - 320)				
1.4864	X12NiCrSi 36-16	1.4865	G-X40NiCrSi38-18	30 (10 - 70)	30 (10 - 70)				
1.4980	X6NiCrTiMoVB25-15-2	1.4876	X10NiCrAlTi32-20	20 (10 - 50)	20 (10 - 50)				
2.4631	NiCr20TiAl (Nimonic 80A)	2.4856	NiCr22Mo9Nb (Inconel 625)	30 (10 - 70)	30 (10 - 70)				
2.4668	NiCr19Nb5Mo3 (Inconel 718)	2.4955	NiFe25Cr20NbTi	20 (10 - 50)	20 (10 - 50)				
2.4765	CoCr20W15Ni	1.3401	G-X120Mn12	20 (10 - 40)	20 (10 - 40)				
3.7025	Ti99,8	3.7035	Ti99,7	30 (10 - 70)	30 (10 - 70)				
3.7164	TiAl6V4	Ti-6246	Ti-6Al-2Sn-4Zr-6Mo	20 (10 - 40)	20 (10 - 40)				
Ti5553	Ti-5Al-5V-5Mo-3Cr	Ti-1023	Ti-10V-2Fe-3Al	20 (10 - 30)	20 (10 - 30)				
				30 (10 - 60)	30 (10 - 60)				
					20 (10 - 50)				
					20 (10 - 40)				
				20 (10 - 30)	20 (10 - 30)				
				90 (40 - 180)	90 (40 - 180)				
				90 (40 - 190)	90 (40 - 190)				
				70 (30 - 160)	70 (30 - 160)				
				50 (20 - 120)	50 (20 - 120)				
				90 (40 - 180)	90 (40 - 180)				



Richtige Schnittgeschwindigkeit ist in Abhängigkeit von Dimension und Anwendungssituation zu wählen.

The correct cutting speed must be selected depending on the dimension and application situation.

20 (10 - 50) bevorzugte Wahl / best choice
20 (10 - 50) bedingt möglich / conditionally possible

20 (10 - 50) empfohlener Startwert recommended starting value (bevorzugter Einsatzbereich) (preferred application area)

Vorschub: feed f: [mm/U] [mm/rev]

Ausspindeln ≤ Ø 3mm: 0.01 - 0.06 mm/U
precision boring ≤ Ø 3mm: 0.01 - 0.06 mm/rev
Ausspindeln > Ø 3mm: 0.02 - 0.1 mm/U
precision boring > Ø 3mm: 0.02 - 0.1 mm/rev

ROTALINE

Ausspindeln
ab Ø 0.4 mm

precision boring
starting at Ø 0.4 mm

Technische Hinweise

Schnittdatenempfehlung:

Technical instructions,
speed and feed recommendation:
imperial

cutting speed (SFM): V_C (feet/min)
feed: f (inch/rev)

Werkstoffgruppe material group		Zusammensetzung composition		(Zug-)Festigkeit tensile strength	
ISO	Beschreibung / description	Gefüge / structure	Wärmebehandlung / heat treatment	Psi / N/mm ² (Rm) / HB / HRC	
P	Unlegierter Stahl unalloyed steel	ca.Japp. 0,15 % C	geglüht / annealed	61000 Psi / 420 N/mm ² / 125 HB	
		ca.Japp. 0,45 % C	geglüht / annealed	93000 Psi / 640 N/mm ² / 190 HB	
		ca.Japp. 0,75 % C	vergütet / tempered	122000 Psi / 840 N/mm ² / 250 HB	
			geglüht / annealed	132000 Psi / 910 N/mm ² / 270 HB	
	Niedriglegierter Stahl low alloyed steel	vergütet / tempered	146500 Psi / 1010 N/mm ² / 300 HB		
		geglüht / annealed	88500 Psi / 610 N/mm ² / 180 HB		
		vergütet / tempered	135000 Psi / 930 N/mm ² / 275 HB		
		vergütet / tempered	146500 Psi / 1010 N/mm ² / 300 HB		
	Hochlegierter (Werkzeug)-Stahl highly alloyed steel	vergütet / tempered	174000 Psi / 1200 N/mm ² / 375 HB		
		geglüht / annealed	99000 Psi / 680 N/mm ² / 200 HB		
gehärtet & angelassen / hardened & tempered		160000 Psi / 1100 N/mm ² / 300 HB			
Nichtrostender Stahl stainless steel	gehärtet & angelassen / hardened & tempered	189000 Psi / 1300 N/mm ² / 400 HB			
	ferritisch, martensitisch / ferritic, martensitic	geglüht / annealed	99000 Psi / 680 N/mm ² / 200 HB		
M	Nichtrostender Stahl stainless steel	martensitisch / martensitic	vergütet / tempered	117500 Psi / 810 N/mm ² / 250 HB	
		austenitisch / austenitic	abgeschreckt / quenched	88500 Psi / 610 N/mm ² / 200 HB	
		austenitisch / austenitic	vergütet / tempered	300 HB	
K	Grauguss cast iron	austenitisch, ferritisch / ferritic, martensitic (Duplex)		113000 Psi / 780 N/mm ² / 230 HB	
		perlitisch, ferritisch / pearlitic, ferritic		51000 Psi / 350 N/mm ² / 180 HB	
	Gusseisen mit Kugelgraphit cast iron with nodular graphite	perlitisch (martensitisch) / pearlitic (martensitic)		72500 Psi / 500 N/mm ² / 260 HB	
		ferritisch / ferritic		72500 Psi / 500 N/mm ² / 160 HB	
Temperguss malleable iron	perlitisch / pearlitic		122500 Psi / 845 N/mm ² / 250 HB		
	ferritisch / ferritic		63800 Psi / 440 N/mm ² / 130 HB		
N	Aluminium - Knetlegierungen wrought aluminum alloys	nicht aushärtbar / uncurable		60 HB	
		aushärtbar / curable	ausgehärtet / cured	49000 Psi / 340 N/mm ² / 100 HB	
	Aluminium - Gusslegierungen cast aluminum alloys	≤ 12% Si, nicht aushärtbar / uncurable		36250 Psi / 250 N/mm ² / 75 HB	
		≤ 12% Si, aushärtbar / curable	ausgehärtet / cured	43500 Psi / 300 N/mm ² / 90 HB	
		> 12% Si, nicht aushärtbar / uncurable		63800 Psi / 440 N/mm ² / 130 HB	
		PB > 1 %, Automatenlegierungen / free cutting alloys		54500 Psi / 375 N/mm ² / 110 HB	
Kupfer und Kupferlegierungen (Bronze / Messing) copper and copper alloys (bronze / brass)	CuZn, CuSnZn		43500 Psi / 300 N/mm ² / 90 HB		
	CuSn, bleifrei & Elektrolytisch / lead free & electrolytic		49000 Psi / 340 N/mm ² / 100 HB		
S	Magnesium & -Legierungen / Mg-alloys	Magnesium und -Legierungen / and -alloys		70 HB	
		Warmfeste Legierungen heat-resistant alloys	Fe-Basis / Fe base	geglüht / annealed	99000 Psi / 680 N/mm ² / 200 HB
				ausgehärtet / cured	137750 Psi / 950 N/mm ² / 280 HB
			Ni- oder Co-Basis / Ni- or Co-Base	geglüht / annealed	122000 Psi / 840 N/mm ² / 250 HB
				ausgehärtet / cured	171000 Psi / 1180 N/mm ² / 350 HB
	Titanlegierungen titanium alloys	gegossen / cast	156600 Psi / 1080 N/mm ² / 320 HB		
		Reintitan / pure titanium		58000 Psi / 400 N/mm ²	
		Alpha- + Beta-Legierungen / -alloys	ausgehärtet / cured	152250 Psi / 1050 N/mm ²	
		Beta-Legierungen / -alloys		203000 Psi / 1400 N/mm ² / 410 HB	
		H	Gehärteter Stahl hardened steel	gehärtet & angelassen / hardened & tempered	
gehärtet & angelassen / hardened & tempered				56-60 HRC	
gehärtet & angelassen / hardened & tempered				61-65 HRC	
gehärtet & angelassen / hardened & tempered				66-70 HRC	
Hartguss / chilled cast iron	gegossen / cast			400 HB	
Gehärtetes Guss / hardened cast iron	gehärtet & angelassen / hardened & tempered		55 HRC		
O	Nichtmetallische Werkstoffe non-metallic materials	Kunststoffe, duroplastisch / plastics, duroplastic		≤ 21750 Psi / ≤ 150 N/mm ²	
		Kunststoffe, thermoplastisch / plastics, thermoplastic		≤ 14500 Psi / ≤ 100 N/mm ²	
		aramidfaserverstärkt / aramid fiber reinforced		≤ 145000 Psi / ≤ 1000 N/mm ²	
		glas/kohlefaserverstärkt / glas/carbon fiber reinforced		≤ 145000 Psi / ≤ 1000 N/mm ²	
		Graphit / graphite			

The correct cutting speed must be selected depending on the dimension and application situation.

20 (10 - 50) best choice
20 (10 - 50) conditionally possible

20 (10 - 50) recommended starting value (preferred application area)

feed f: [inch/rev]

precision boring ≤ Ø 3mm: 0.0004 - 0.0024 in/rev

precision boring > Ø 3mm: 0.0008 - 0.0039 in/rev



duemmel.de



AXALINE

D min. $\geq \varnothing 5.0$ mm

AXALINE

Rotierender Einsteckkopf
für flexible Systemlösungen

rotating grooving head
for flexible system solutions

Übersicht

summary

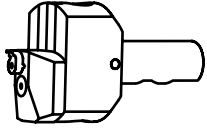

Allgemeine Beschreibung

general instructions

... 5



Einsteckkopf

grooving head

**Maße
dimensions
[mm]**

**Seite
page**

Typ Axaline

Grundhalter und Klemmhalter
für Ultramini, Minicut und
DED

basic holder and toolholder
for Ultramini, Minicut and
DED

... 6

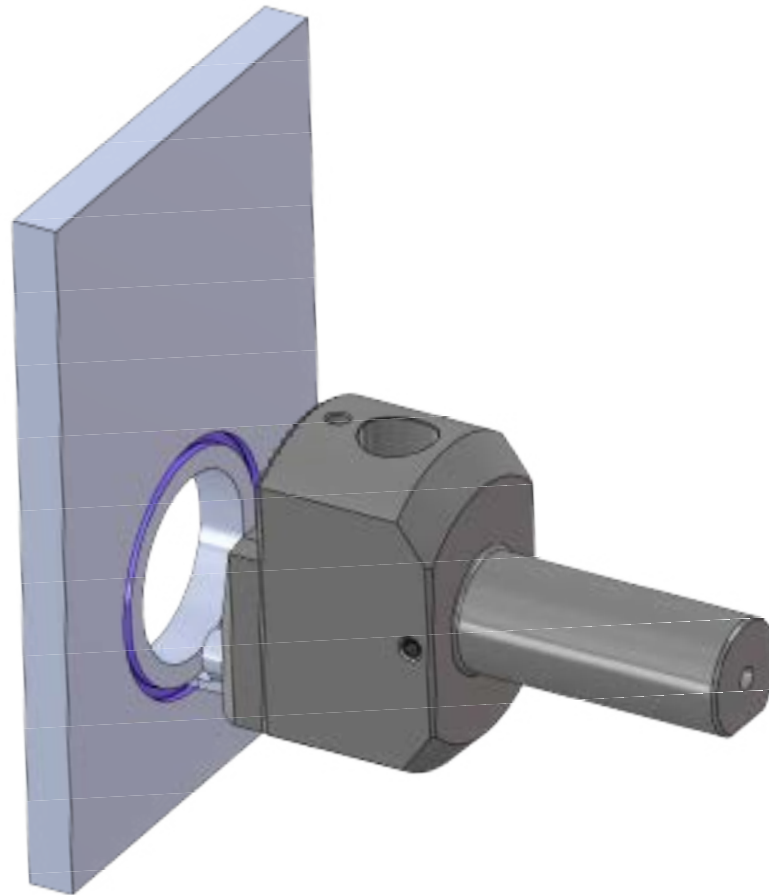

Anwendungsbeispiel
application example

AXALINE

Rotierender Einsteckkopf
für flexible Systemlösungen

rotating grooving head
for flexible system solutions

Übersicht

summary

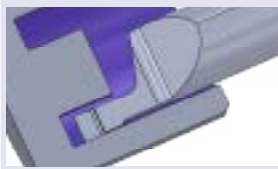

ULTRAMINI



Schneideinsätze
Axialstechen

inserts
face grooving

Maße
dimensions
[mm]

Seite
page

Typ 510M

Axialstechen
mit Eckenradius

face grooving
with corner radius

D min. 5.0
t max. 4.0

... 8

Typ 010M

Axialstechen
mit Eckenradius

face grooving
with corner radius

D min. 8.0
t max. 6.0

... 9

Typ 012 / 016

Axialstechen
mit Eckenradius
und doppeltem Kühlkanal

face grooving
with corner radius
and double internal cooling

D min. 12.0
t max. 20

... 11

Typ 020

Axialstechen
mit Eckenradius
und doppeltem Kühlkanal

face grooving
with corner radius
and double internal cooling

D min. 20.0
t max. 40

... 12



MINICUT



Schneideinsätze
Axialstechen

inserts
face grooving

Maße
dimensions
[mm]

Seite
page

Typ Axialstechen

allgemein

type face grooving

D min. 14
t max. 6

... 13



STECHDREH-WERKZEUGE System DED



Wendeschneidplatten
Stechdrehen

indexable inserts
grooving

Maße
dimensions
[mm]

Seite
page

**Typ Stechdrehen
DED / DED.XL**

DED Wendeschneidplatte,
Axialbearbeitung

DED indexable insert,
face grooving

D min. 20.0
t max. 5

... 14

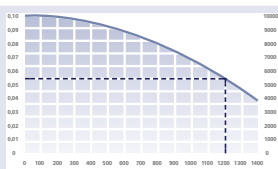

Technische Hinweise

Technical Instructions

Seite
page

Grundsätzliche Informationen zum
Werkzeugprogramm Axaline

Basic informations about the tool
program Axaline

... 15

Schnittdatenempfehlung

speed and feed recommendation

... 16

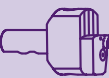

AXALINE

Rotierender Einsteckkopf
für flexible Systemlösungen

rotating grooving head
for flexible system solutions

Impressionen

impressions

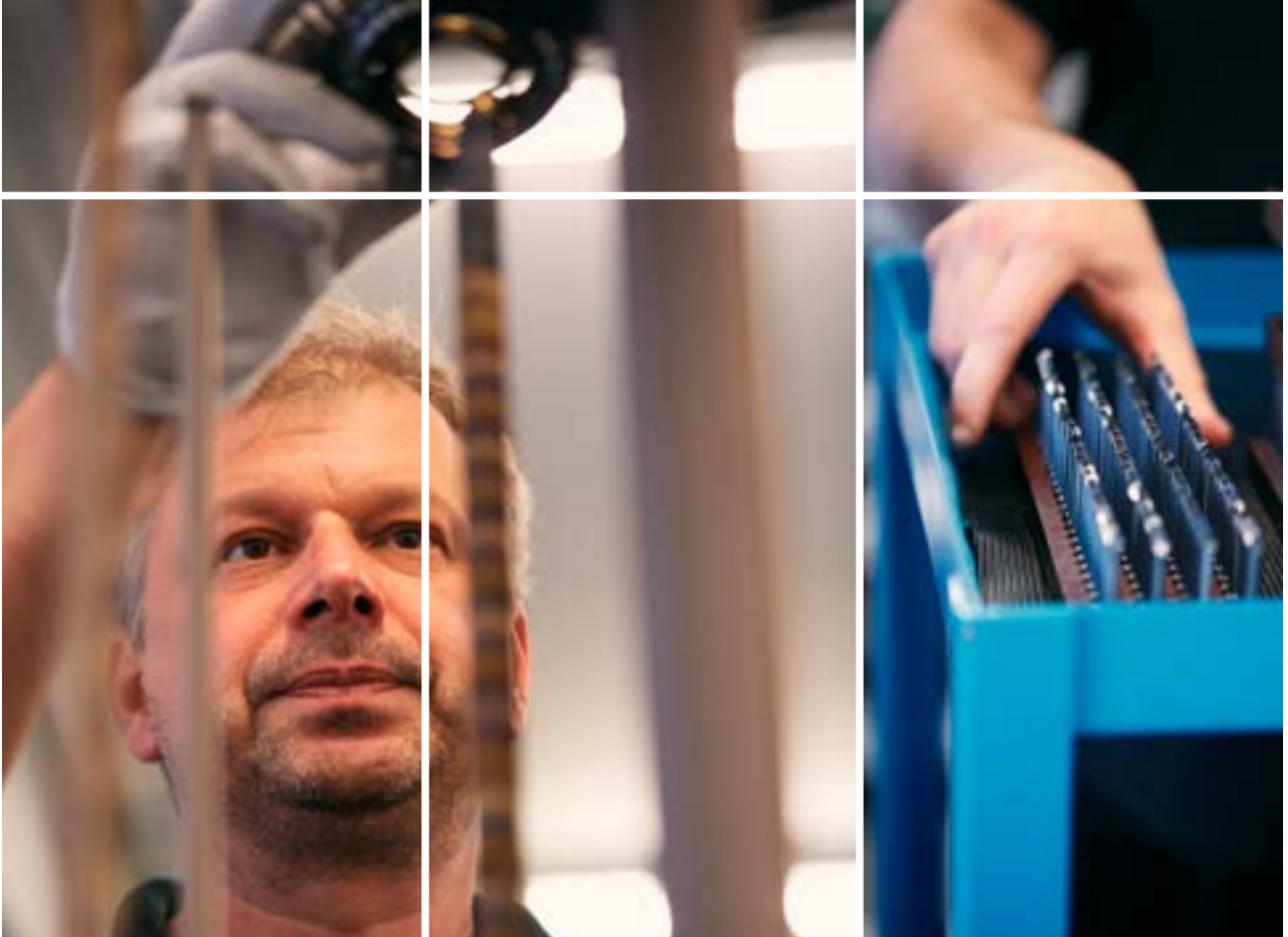

AXALINE

Rotierender Einsteckkopf
für flexible Systemlösungen

rotating grooving head
for flexible system solutions

Allgemeine Beschreibung

general instruction

Der rotierende Einsteckkopf für die funktionale Fertigung von Ringnuten auf Bearbeitungszentren und Fräsmaschinen. Einfaches Handling und ein großer Durchmesserbereich zeichnen dieses Werkzeug aus. Durch verschiedene Klemmhalter können viele Standardwerkzeuge aus unserem Programm eingesetzt werden, auch Sonderlösungen sind jederzeit möglich.

The rotating grooving head for the functional production of ring grooves on machining centres or milling machines. Easy handling and a large diameter range characterizes this tool. Many standard inserts from our program can be used by different toolholders. And also customized, special solutions are always possible.

Basisdaten basic informations

axiale Nutbearbeitung face grooving		Ø5 - Ø130 mm	
Körperdurchmesser body diameter		Ø70 mm	
Aufnahme interface diameter		Ø25 mm	
Schneideinsätze inserts	Ultramini:	Spannschaft / clamp shank Ø5 h6 Ø7 h6 Ø8 h6	Klemmhalter für rechte Schneiden ausgelegt, andere Ausführungen auf Anfrage. toolholder for righthand inserts designed, other versions on request.
	Minicut:	RS014	
	DED:	Sonderanfertigung/ custom made insert	

Kühlmittelzufuhr direkt an die Schneide.

the coolant medium is directly transported to the cutting edge

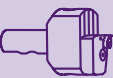
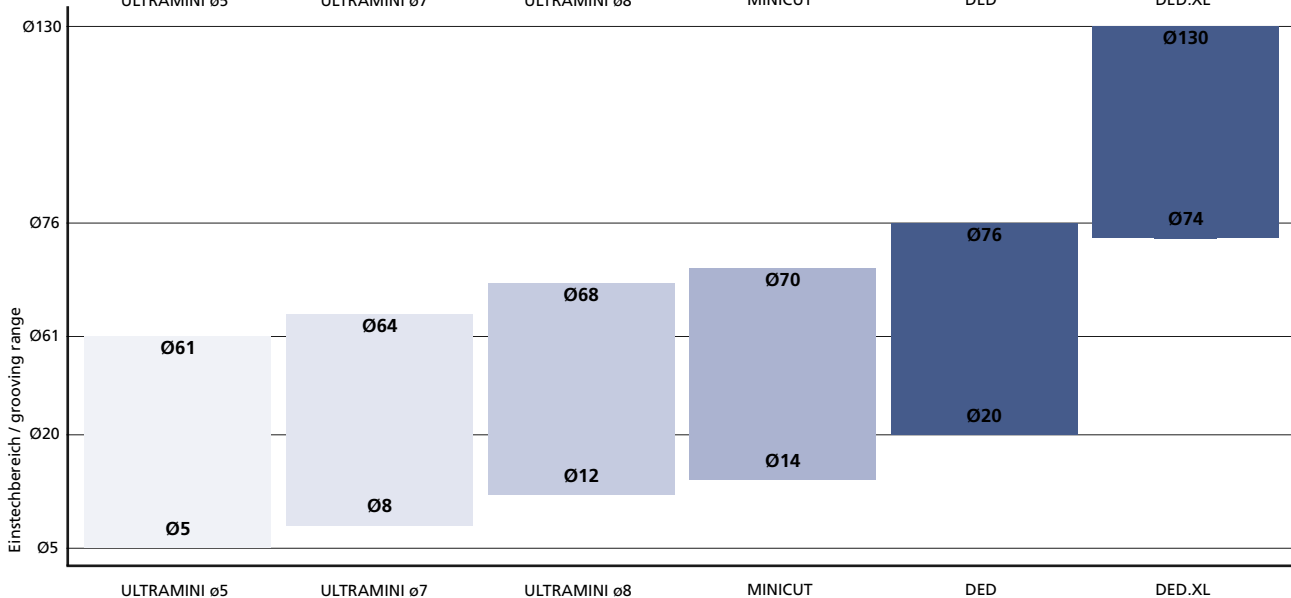
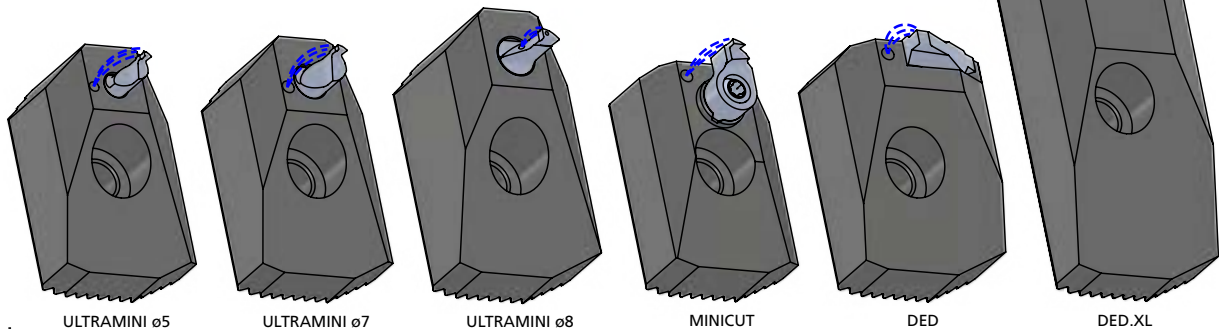

AXALINE

Rotierender Einsteckkopf
für flexible Systemlösungen

rotating grooving head
for flexible system solutions

Typ Axaline

Grundhalter und Klemmhalter
für Ultramini, Minicut und
DED

basic holder and toolholder
for Ultramini, Minicut and
DED

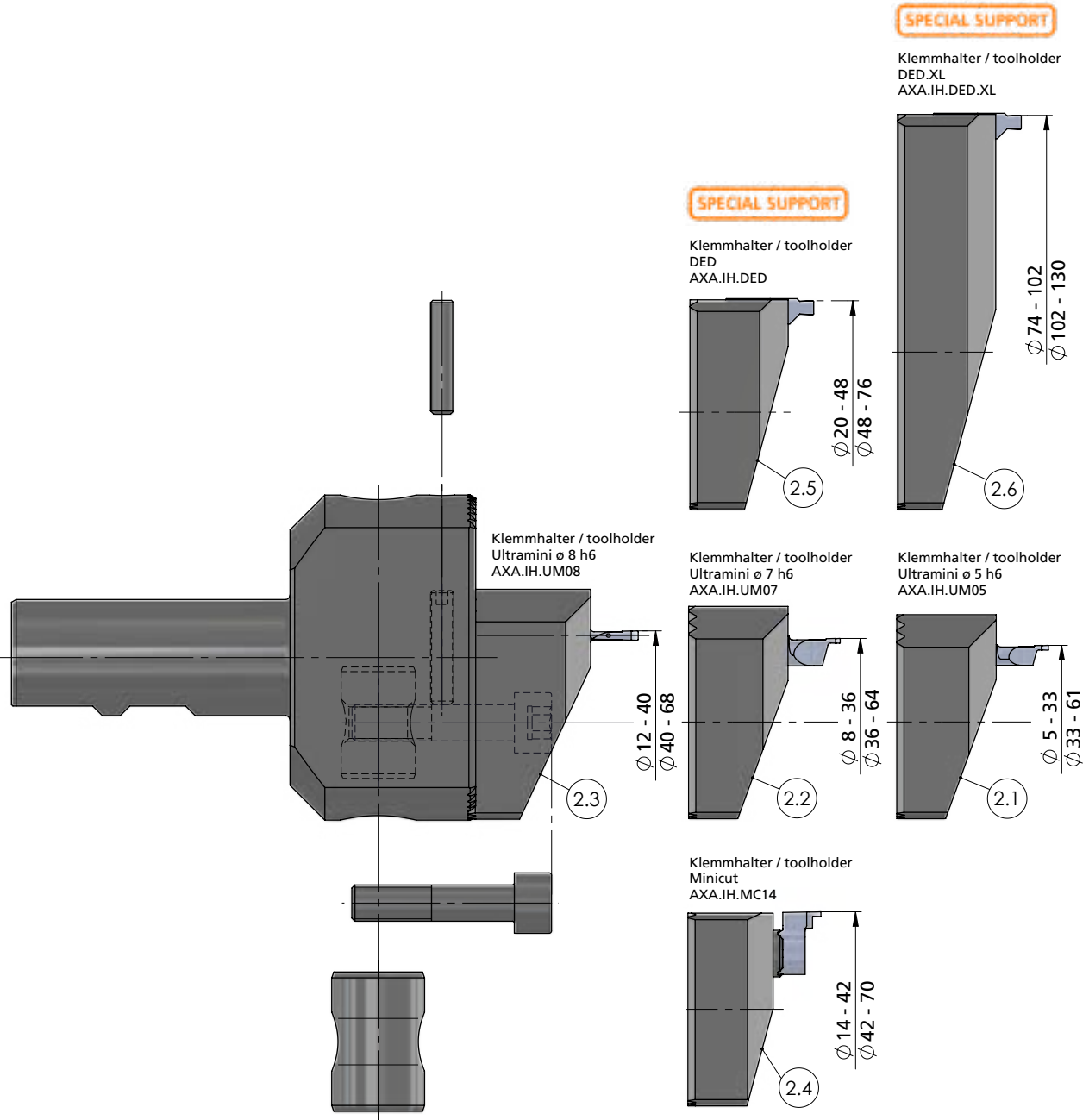

AXALINE

Rotierender Einsteckkopf für flexible Systemlösungen

rotating grooving head for flexible system solutions

Typ Axaline

Grundhalter und Klemmhalter für Ultramini, Minicut und DED

basic holder and toolholder for Ultramini, Minicut and DED

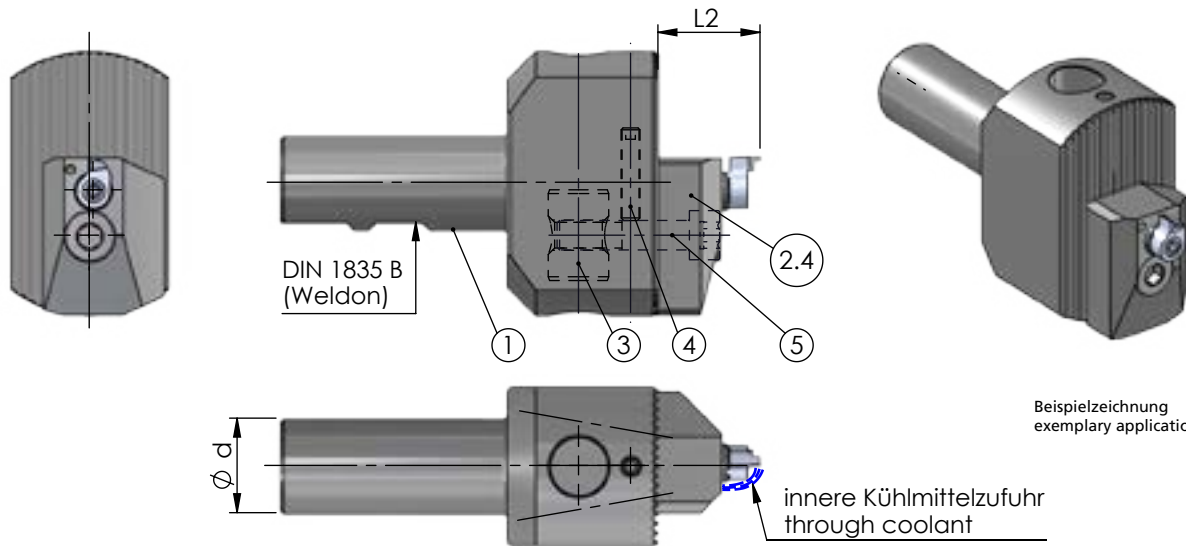

Abmessungen in mm

dimensions in mm



Bestellnummer part number	Position	Bezeichnung description	Ø d	L2	Spannschraube screw	Schraubenschlüssel wrench	Anzugsdrehmoment torque	Schneideinsatz * insert *	Spannschaft rechter Schneideinsatz / *	clamp shank righthand insert *
AXA.BH.0576.25.B	1	Grundhalter / basic holder	25							
AXA.IH.UM05	2.1	Ultramini	31 - 40		A.GST004	111.645	1.2 Nm		Ø 5 h6	
AXA.IH.UM07	2.2	Ultramini	31 - 50		A.GST004	111.645	1.2 Nm		Ø 7 h6	
AXA.IH.UM08	2.3	Klemmhalter / toolholder	Ultramini	35 - 65	A.GST001	111.INB3	2.5 Nm		Ø 8 h6	
AXA.IH.MC14	2.4	Minicut	27 - 30		A.SPS026	TR15-P	4.5 Nm	RS014		
AXA.IH.DED	2.5	DED	25		A.SPS011	T20F-P	6.0 Nm	DED		
AXA.IH.DED.XL	2.6	DED.XL	25		A.SPS011	T20F-P	6.0 Nm	DED		

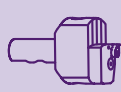

Ersatzteile / spare parts										
Bestellnummer part number	Position	Bezeichnung description	Ø d	L2	Spannschraube screw	Schraubenschlüssel wrench	Anzugsdrehmoment torque	Schneideinsatz * insert *	Spannschaft rechter Schneideinsatz / *	clamp shank righthand insert *
AXA.ET.SB1624	3	Spannbolzen / clamping bolt								
AXA.ET.GSM524	4	Gewindestift / threaded pin				111.645				
AXA.ET.ZSM835	5	Zylinderschraube / cylinder screw				911XL	20 Nm			

* Schneiden sind im Lieferumfang nicht enthalten.

* inserts are not included in the scope of delivery

Bestellbeispiel:
AXA.BH.0576.25.B + AXA.IH.UM05

order-example:
AXA.BH.0576.25.B + AXA.IH.UM05

AXALINE

Rotierender Einstechkopf
für flexible Systemlösungen

rotating grooving head
for flexible system solutions

Typ 510M

Axialstechen
mit Eckenradius

face grooving
with corner radius

Ultramini

D min. 5.0 mm
Stechtiefe t max. 4.0 mm
Nutbreite bis 2.0 mm

D min. 5.0 mm
depth of groove t max. 4.0 mm
width of groove up to 2.0 mm

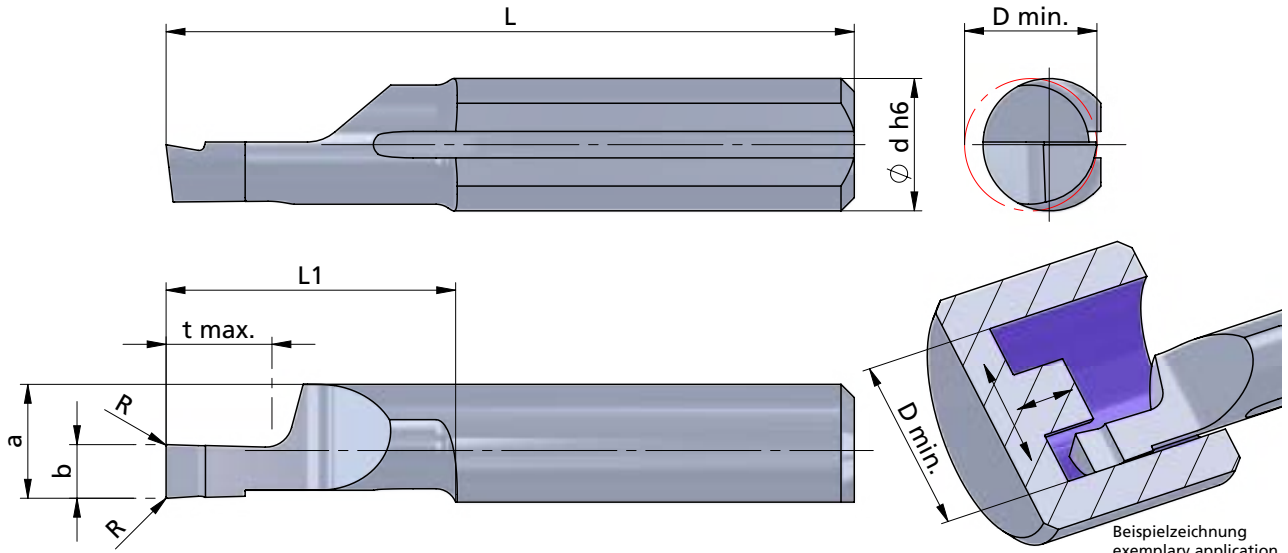

Beispielzeichnung
exemplary application

Rechts (R): wie gezeichnet

righthand (R): as shown

Abmessungen in mm

dimensions in mm

Bestellnummer part number	b +0.05	a	L	L1	t max.	D min.	Ø d h6	R	*				Klemmhalter Typ toolholder type
									K10F	CN45F	AL41F	P07C	
R/- 510M0508-10	0.5	4.3	26	11	1.0	5.0	5.0	0.05			●		AXA.IH.UJ05
R/- 510M0808-10	0.8	4.3	26	11	2.0	5.0	5.0	0.05			●		
R/- 510M1008-10	1.0	4.3	26	11	2.0	5.0	5.0	0.05			●		
R/- 510M1508-10	1.5	4.3	26	11	3.0	5.0	5.0	0.05			●		
R/- 510M2008-10	2.0	4.3	26	11	4.0	5.0	5.0	0.05			●		
R/- 510M1008-20	1.0	4.3	35	20	2.0	5.0	5.0	0.05			●		
R/- 510M1508-20	1.5	4.3	35	20	3.0	5.0	5.0	0.05			●		
R/- 510M2008-20	2.0	4.3	35	20	4.0	5.0	5.0	0.05			●		

* Weitere HM Sorten können Sie in der Sortenübersicht im Kapitel "Technische Hinweise" des Programms Ultramini und der Preisliste finden.

Bestellbeispiel:
für rechte Ausführung und Sorte
R510M0508-10/AL41F

* More carbide grades you can find in the grades summary in the chapter "technical instructions" of the program Ultramini and in the price list.

order-example:
righthand version and grade
R510M0508-10/AL41F

AXALINE

Rotierender Einstechkopf für flexible Systemlösungen

rotating grooving head for flexible system solutions

Typ 010M

Axialstechen mit Eckenradius

face grooving with corner radius

Ultramini

D min. 8.0 mm
Stechtiefe t max. 6.0 mm
Nutbreite bis 3.0 mm

D min. 8.0 mm
depth of groove t max. 6.0 mm
width of groove up to 3.0 mm

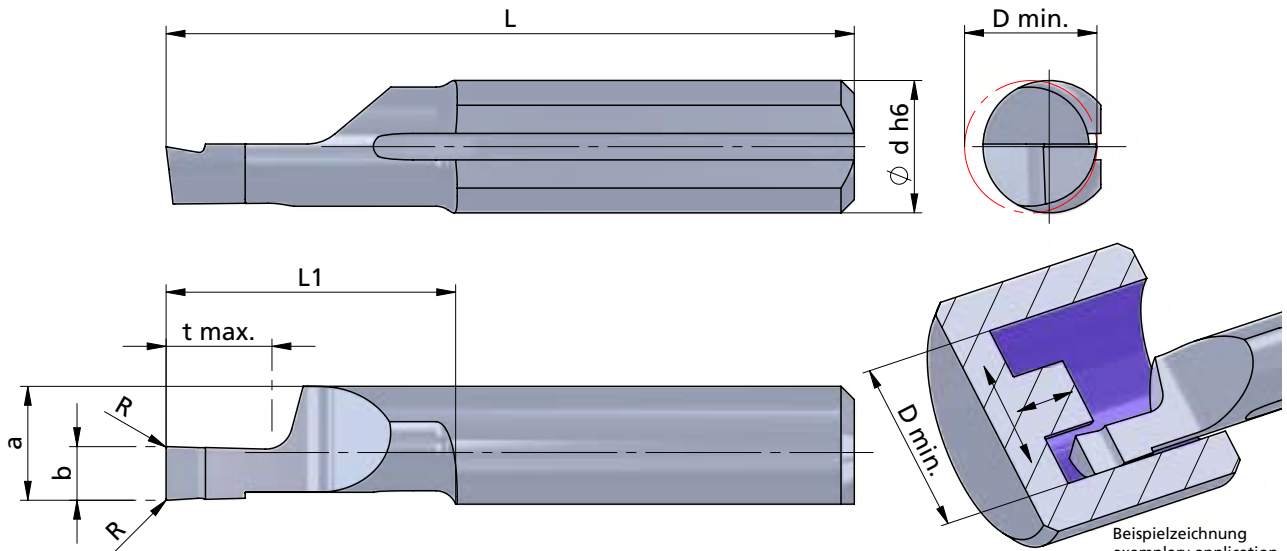

Rechts (R): wie gezeichnet

righthand (R): as shown

Abmessungen in mm

dimensions in mm

Bestellnummer part number	b +0.05	b (inch)	a	L	L1	t max.	D min.	Ø d h6	R	*				Klemmhalter Typ toolholder type
										K10F	CN45F	AL41F	NEME	
R/- 010M1008-10	1.0		5.9	26	11	2.0	8.0	7.0	0.1		●			AXA.IH.UM07
R/- 010M1508-10	1.5		5.9	26	11	3.0	8.0	7.0	0.1		●			
R/- 010M1578-10	1.57	0.062"	5.9	26	11	3.0	8.0	7.0	0.1		●			
R/- 010M2008-10	2.0		5.9	26	11	4.0	8.0	7.0	0.1		●	●		
R/- 010M2508-10	2.5		5.9	26	11	5.0	8.0	7.0	0.1		●			
R/- 010M3008-10	3.0		5.9	26	11	6.0	8.0	7.0	0.1		●			
R/- 010M1008-20	1.0		5.9	35	20	2.0	8.0	7.0	0.1		●			
R/- 010M1508-20	1.5		5.9	35	20	3.0	8.0	7.0	0.1		●			
R/- 010M2008-20	2.0		5.9	35	20	4.0	8.0	7.0	0.1		●			
R/- 010M2308-20	2.38	0.094"	5.9	35	20	5.0	8.0	7.0	0.1		●			
R/- 010M2508-20	2.5		5.9	35	20	5.0	8.0	7.0	0.1		●			
R/- 010M3008-20	3.0		5.9	35	20	6.0	8.0	7.0	0.1		●			
↳ ...														

* Weitere HM Sorten können Sie in der Sortenübersicht im Kapitel "Technische Hinweise" des Programms Ultramini und der Preisliste finden.

Bestellbeispiel:
für rechte Ausführung und Sorte
R010M1008-10/AL41F

* More carbide grades you can find in the grades summary in the chapter "technical instructions" of the program Ultramini and in the price list.

order-example:
righthand version and grade
R010M1008-10/AL41F

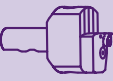

AXALINE

Rotierender Einstechkopf
für flexible Systemlösungen

rotating grooving head
for flexible system solutions

Typ 010M

Axialstechen
mit Eckenradius

face grooving
with corner radius

Ultramini

D min. 8.0 mm
Stechtiefe t max. 6.0 mm
Nutbreite bis 3.0 mm

D min. 8.0 mm
depth of groove t max. 6.0 mm
width of groove up to 3.0 mm

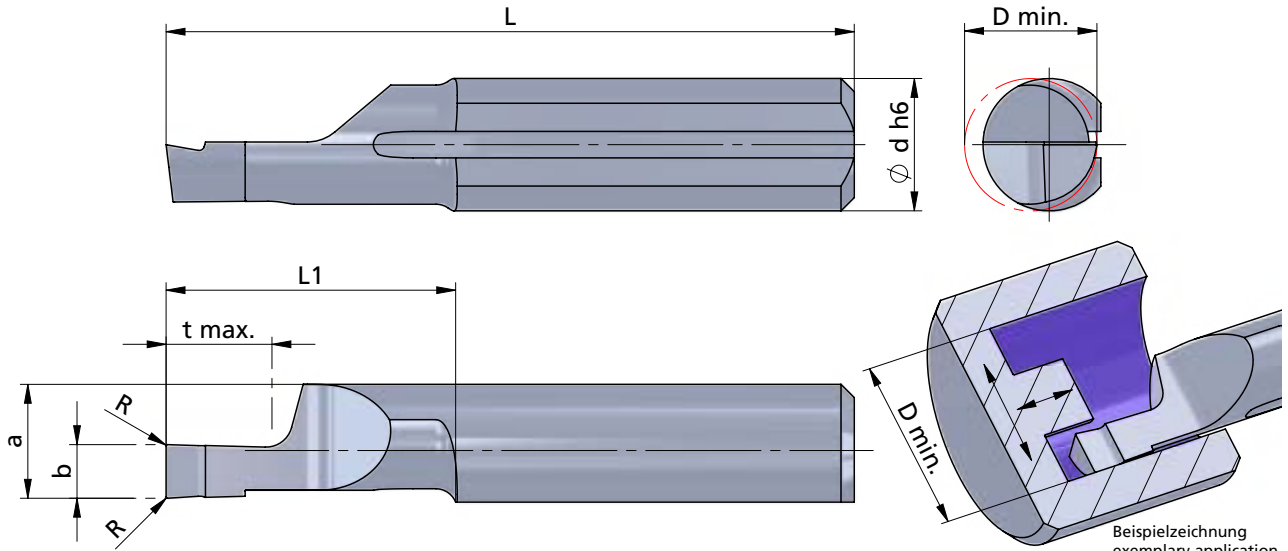

Rechts (R): wie gezeichnet

righthand (R): as shown

Abmessungen in mm

dimensions in mm

Bestellnummer part number	b +0.05	b (inch)	a	L	L1	t max.	D min.	Ø d h6	R	*				Klemmhalter Typ toolholder type	
										K10F	CN45F	AL41F	P07C		
...															
R/- 010M1008-30	1.0		5.9	45	30	2.0	8.0	7.0	0.1		●				
R/- 010M1508-30	1.5		5.9	45	30	3.0	8.0	7.0	0.1		●				
R/- 010M2008-30	2.0		5.9	45	30	4.0	8.0	7.0	0.1		●				
R/- 010M2508-30	2.5		5.9	45	30	5.0	8.0	7.0	0.1		●				
R/- 010M3008-30	3.0		5.9	45	30	6.0	8.0	7.0	0.1		●				AXA.IH.JUM07

* Weitere HM Sorten können Sie in der Sortenübersicht im Kapitel "Technische Hinweise" des Programms Ultramini und der Preisliste finden.

Bestellbeispiel:
für rechte Ausführung und Sorte
R010M1008-30/AL41F

* More carbide grades you can find in the grades summary in the chapter "technical instructions" of the program Ultramini and in the price list.

order-example:
righthand version and grade
R010M1008-30/AL41F

AXALINE

Rotierender Einstechkopf für flexible Systemlösungen

rotating grooving head for flexible system solutions

Typ 012 / 016

Axialstechen mit Eckenradius und doppeltem Kühlkanal

face grooving with corner radius and double internal cooling

Ultramini

D min. 12 mm
Stechtiefe t max. 20 mm
Nutbreite bis 4.0 mm

D min. 12 mm
depth of groove t max. 20 mm
width of groove up to 4.0 mm

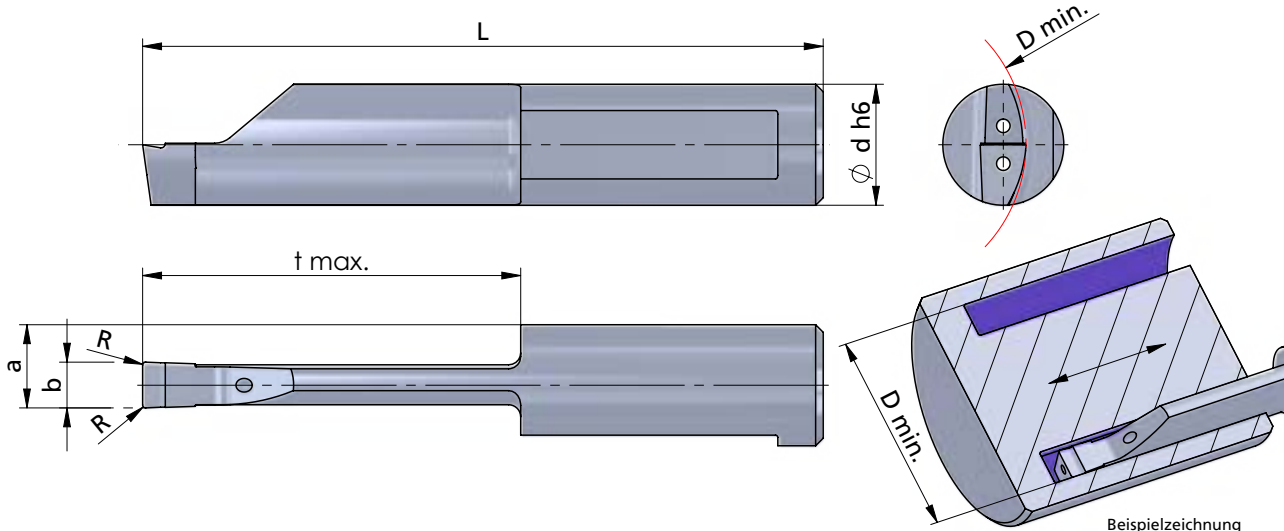

Beispielzeichnung exemplary application

Rechts (R): wie gezeichnet

Kühlmitteldruckempfehlung
70 bar

Abmessungen in mm

righthand (R): as shown

Coolant pressure recommendation
70 bar

dimensions in mm



Bestellnummer part number	b +0.05	a	L	t max.	D min.	Ø d h6	R	*				Klemmhalter Typ toolholder type
								K10F	CN45F	AL41F	PD2F	
R/- 012.0200-10	2.0	5.00	30	10	12	8.0	0.2			●		AXA.IH.UJ08
R/- 012.0200-15	2.0	5.00	35	15	12	8.0	0.2			●		
R/- 012.0250-10	2.5	5.25	30	10	12	8.0	0.2			●		
R/- 012.0250-20	2.5	5.25	40	20	12	8.0	0.2			●		
R/- 016.0300-10	3.0	5.50	30	10	16	8.0	0.2			●	●	
R/- 016.0300-20	3.0	5.50	40	20	16	8.0	0.2			●	●	
R/- 016.0400-10	4.0	6.00	30	10	16	8.0	0.2			●	●	
R/- 016.0400-20	4.0	6.00	40	20	16	8.0	0.2			●	●	

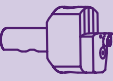

* Weitere HM Sorten können Sie in der Sortenübersicht im Kapitel "Technische Hinweise" des Programms Ultramini und der Preisliste finden.

Bestellbeispiel:
für rechte Ausführung und Sorte
R012.0200-10/AL41F

* More carbide grades you can find in the grades summary in the chapter "technical instructions" of the program Ultramini and in the price list.

order-example:
righthand version and grade
R012.0200-10/AL41F

AXALINE

Rotierender Einstechkopf
für flexible Systemlösungen

rotating grooving head
for flexible system solutions

Typ 020

Axialstechen
mit Eckenradius
und doppeltem Kühlkanal

face grooving
with corner radius
and double internal cooling

Ultramini

D min. 20 mm
Stechtiefe t max. 40 mm
Nutbreite bis 5.0 mm

D min. 20 mm
depth of groove t max. 40 mm
width of groove up to 5.0 mm

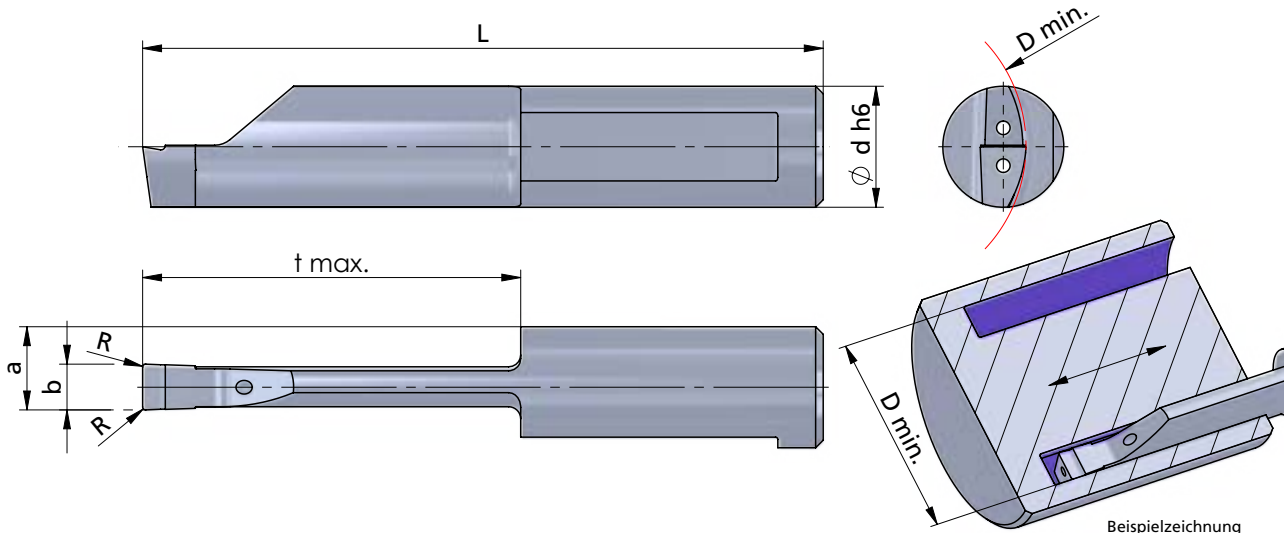

Beispielzeichnung
exemplary application

Rechts (R): wie gezeichnet

Kühlmitteldruckempfehlung
70 bar

Abmessungen in mm

righthand (R): as shown

Coolant pressure recommendation
70 bar

dimensions in mm



Bestellnummer part number	b +0.05	a	L	t max.	D min.	Ø d h6	R	*				Klemmhalter Typ toolholder type
								K10F	CN45F	AL41F	PD2F	
R/- 020.0300-25	3.0	5.5	45	25	20	8.0	0.2			●	●	AXA.IH.JM08
R/- 020.0300-30	3.0	5.5	50	30	20	8.0	0.2			●	●	
R/- 020.0300-35	3.0	5.5	55	35	20	8.0	0.2			●	●	
R/- 020.0300-40	3.0	5.5	60	40	20	8.0	0.2			●	●	
R/- 020.0400-25	4.0	6.0	45	25	20	8.0	0.2			●	●	
R/- 020.0400-30	4.0	6.0	50	30	20	8.0	0.2			●	●	
R/- 020.0400-35	4.0	6.0	55	35	20	8.0	0.2			●	●	
R/- 020.0400-40	4.0	6.0	60	40	20	8.0	0.2			●	●	
R/- 020.0500-20	5.0	6.5	40	20	20	8.0	0.2			●	●	
R/- 020.0500-25	5.0	6.5	45	25	20	8.0	0.2			●	●	
R/- 020.0500-30	5.0	6.5	50	30	20	8.0	0.2			●	●	
R/- 020.0500-35	5.0	6.5	55	35	20	8.0	0.2			●	●	
R/- 020.0500-40	5.0	6.5	60	40	20	8.0	0.2			●	●	

*
Weitere HM Sorten können Sie in der Sorten-
übersicht im Kapitel "Technische Hinweise" des
Programms Ultramini und der Preisliste finden.

Bestellbeispiel:
für rechte Ausführung und Sorte
R020.0300-25/AL41F

*
More carbide grades you can find in the grades
summary in the chapter "technical instructions"
of the program Ultramini and in the price list.

order-example:
righthand version and grade
R020.0300-25/AL41F

AXALINE

Rotierender Einstechkopf für flexible Systemlösungen

rotating grooving head for flexible system solutions

Typ Axialstechen

allgemein

type face grooving

Minicut

D min. 14 mm
Stechtiefe t max. 6 mm
Nutbreite bis 3.0 mm

D min. 14 mm
depth of groove t max. 6 mm
width of groove up to 3.0 mm

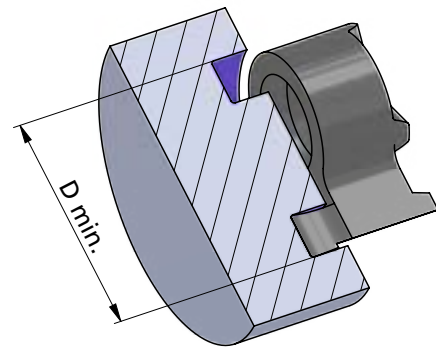
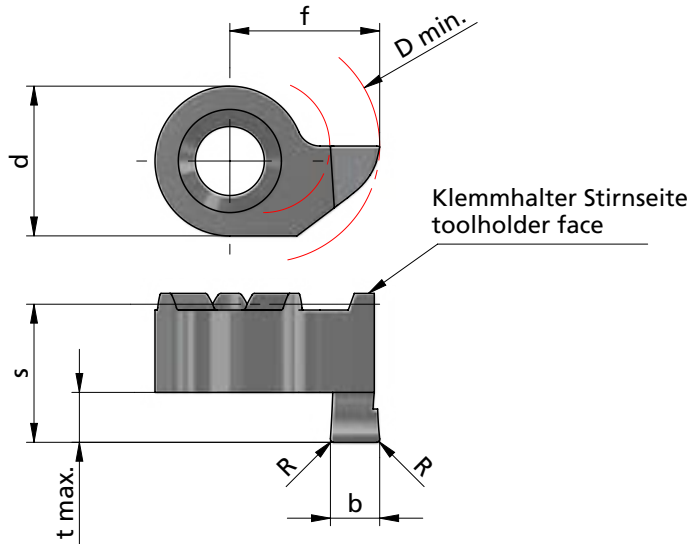

Beispielzeichnung
exemplary application

Rechts (R): wie gezeichnet

righthand (R): as shown

Abmessungen in mm

dimensions in mm

Bestellnummer part number	b		f	R	s	d	t max.	D min.	*			Klemmhalter Typ toolholder type
	b+0.03	b (inch)							K10F	AL41F	P18C	
R/- S014.1410.00	1.0		9	-	8.3	9	1.5	14	●			AXA..IH.MC.14
R/- S014.U411.00	1.17	0.046"	9	-	8.3	9	1.5	14		●		
R/- S014.1415.02	1.5		9	0.2	8.3	9	2.5	14	●	●		
R/- S014.1420.02	2.0		9	0.2	8.3	9	3.0	14	●	●		
R/- S014.1425.02	2.5		9	0.2	8.3	9	3.0	14	●	●		
R/- S014.1430.02	3.0		9	0.2	8.3	9	3.0	14		●		
R/- S014.1420.52	2.0		9	0.2	10.3	9	5.0	14	●	●		
R/- S014.1425.52	2.5		9	0.2	10.3	9	5.0	14	●	●		
R/- S014.1430.52	3.0		9	0.2	10.3	9	5.0	14	●	●		
R/- S014.1430.62	3.0		9	0.2	11.3	9	6.0	14		●		

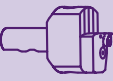

*
Weitere HM Sorten können Sie in der Sortenübersicht im Kapitel "Technische Hinweise" des Programms Minicut und der Preisliste finden.

Bestellbeispiel:
für rechte Ausführung und Sorte
RS014.1410.00/AL41F

*
More carbide grades you can find in the grades summary in the chapter "technical instructions" of the program Minicut and in the price list.

order-example:
righthand version and grade
RS014.1410.00/AL41F

AXALINE

Rotierender Einstechkopf
für flexible Systemlösungen

rotating grooving head
for flexible system solutions

Typ DED / DED.XL

DED Wendeschneidplatte,
Axialbearbeitung

DED indexable insert,
face grooving

Stechdrehen

D min. 20 mm
Stechtiefe t max. 5.0
Stechbreite C max 5.0 mm

D min. 20 mm
depth of groove t max. 5.0
width of groove C max. 5.0 mm

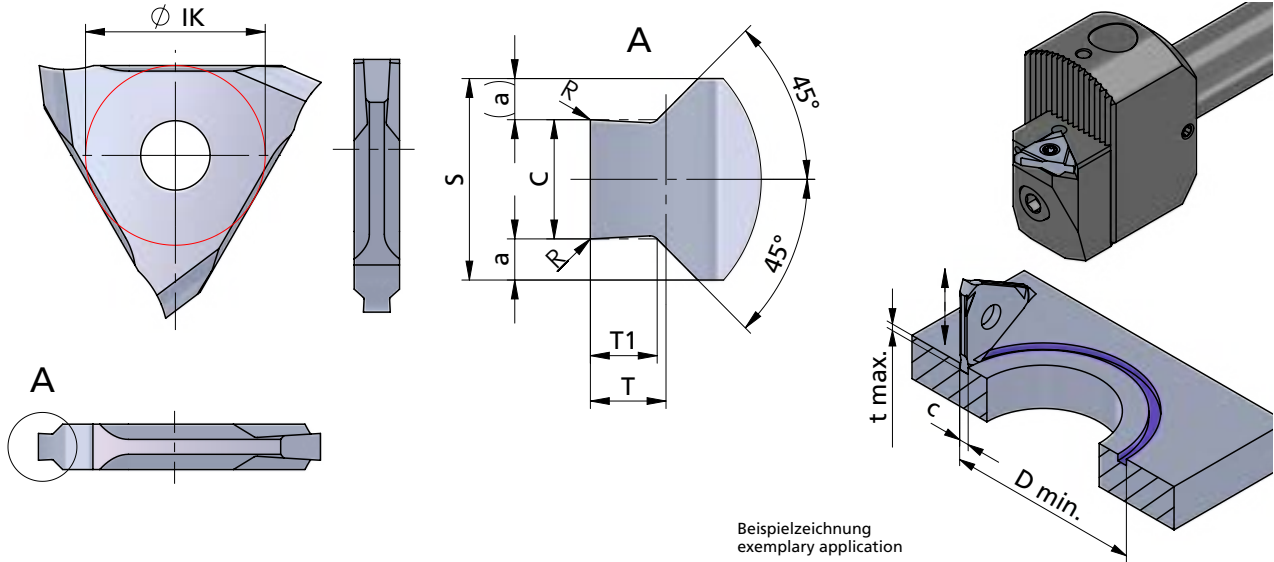

Abmessungen in mm

dimensions in mm

Bestellnummer
part number

C

S

a

R

T

T1

t max.

Ø IK

D min.

K10F

CN45F

AL41F *

P07C

Klemmhalter Typ

toolholder type

AXA.IH.DED
AXA.IH.DED.XL

Profilbeispiele / Examples of profiles

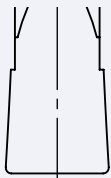

Profil mittig
profile in the middle

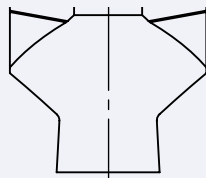

Nutaußenkantenfasung
with chamfer



Vollradius
full radius

**Momentan haben wir keine Standardschneiden im Programm.
Gerne fertigen wir nach Ihren Anforderungen Sonderschneiden.**

**At the moment we do not have any standard inserts in our program.
We are happy to manufacture special inserts according to your requirements.**

*

Weitere HM Sorten können Sie in der Sortenübersicht im Kapitel "Technische Hinweise" des Programms "Stechdrehen DED" und der Preisliste finden.

Bestellbeispiel:
auf Anfrage

*

More carbide grades you can find in the grades summary in the chapter "technical instructions" of the program "Stechdrehen DED" and in the price list.

order-example:
on request

AXALINE

Rotierender Einstechkopf
für flexible Systemlösungen

rotating grooving head
for flexible system solutions

Technische Hinweise

Grundsätzliche Informationen zum
Werkzeugprogramm Axaline

Technical instructions,
Basic informations about the
tool program Axaline

Technische Daten technical data

Anzugsmoment Zylinderschraube M8 tightening torque cylinder screw M8		20 Nm	
maximal zulässige Drehzahl maximum permissible speed	$n_{\max.}$	4000 U/min.	zuerst erreichter Grenzwert ($n_{\max.}$ oder $v_{c \max.}$) gilt! limit value ($n_{\max.}$ or $v_{c \max.}$) reached first applies!
maximal zulässige Schnittgeschwindigkeit maximum permissible cutting speed	$v_{c \max.}$	400 m/min.	
Vorschub feed	f	0.02 ... 0.15	

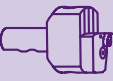
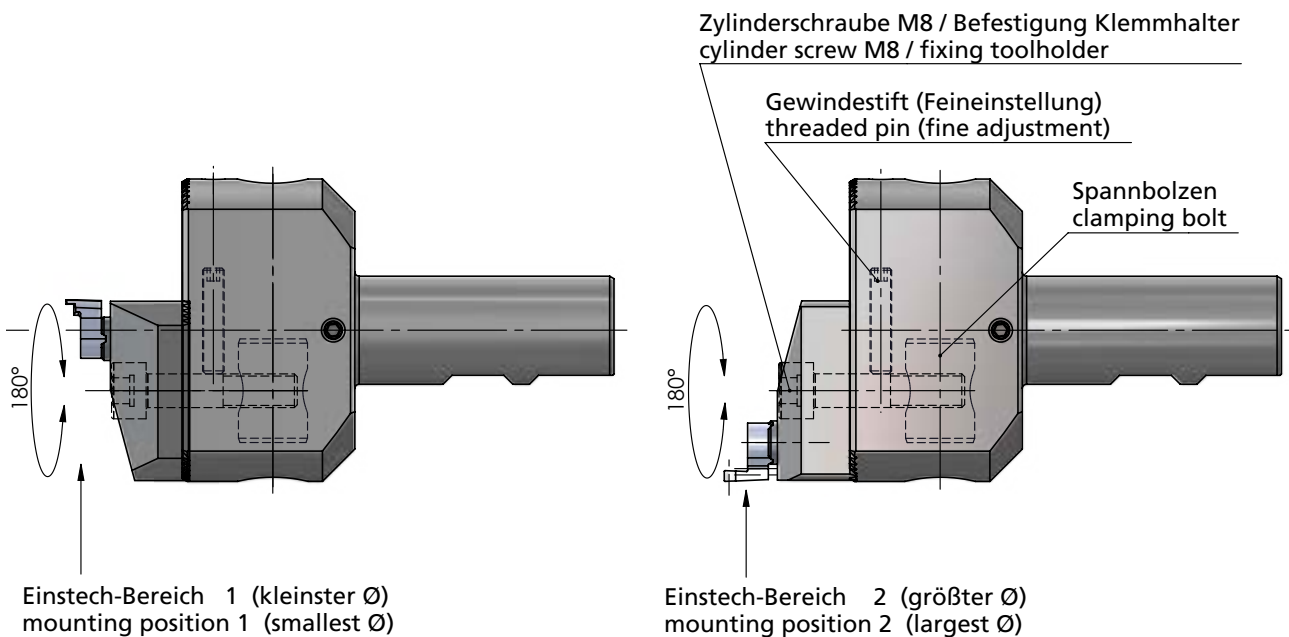

AXALINE

Rotierender Einsteckkopf
für flexible Systemlösungen

rotating grooving head
for flexible system solutions

Technische Hinweise

Schnittdatenempfehlung

Technical instructions,
speed and feed recommendation

Sehr allgemeine Schnittdatenempfehlungen / * Very general cutting data recommendations *

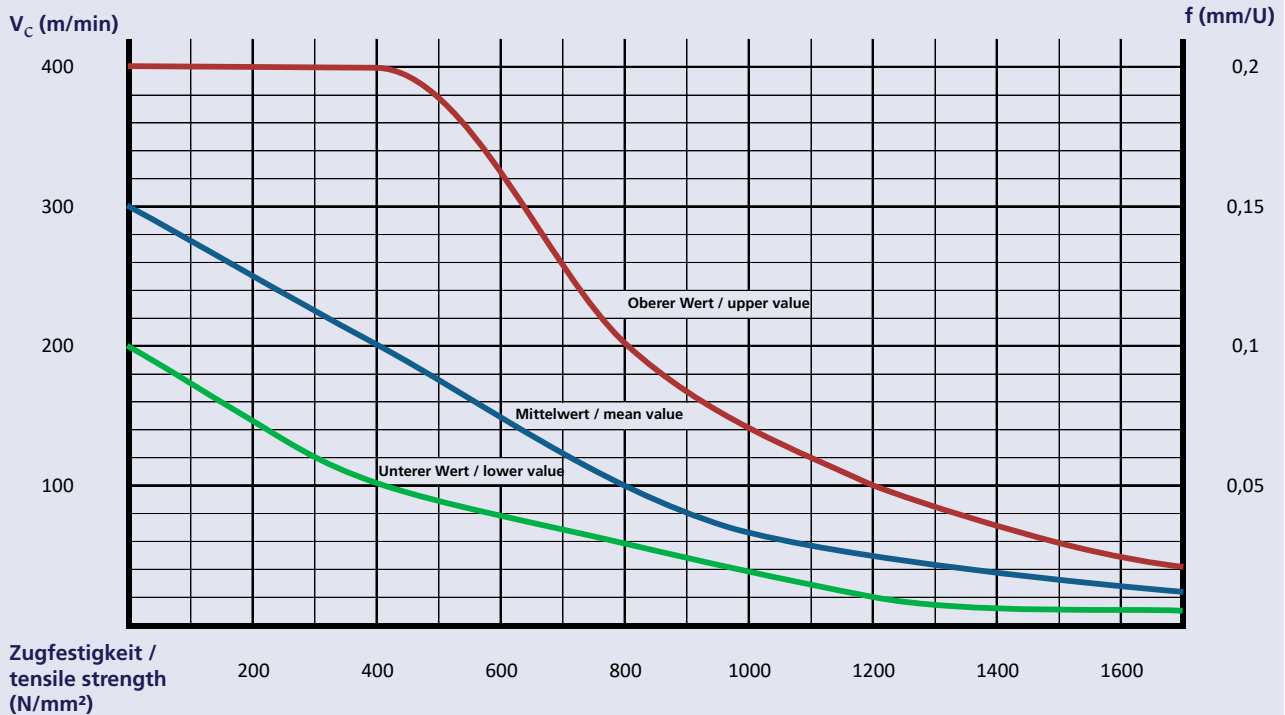

Zugfestigkeit /
tensile strength
(N/mm²)

Anmerkung:

Bei der Wahl der Schnittdaten sind vielerlei Einflüsse zu berücksichtigen, wie z.B. Werkstückspannung und Werkzeugaufbau. Ebenfalls sollte die Zerspanbarkeit des Werkstoffs mit berücksichtigt werden. Bei gut zerspanbaren Materialien kann im Bereich des Mittelwertes gestartet werden, schlecht zerspanbare am unteren Wert. Wir empfehlen grundsätzlich mit kleineren Werten zu starten und diese dann in der Praxis zu optimieren.

Remark:

When choosing the cutting data, a variety of influences must be taken into account, such as workpiece clamping and tool structure. The machinability of the material should also be taken into account. In the case of materials that can be machined well, you can start in the area of the mean value, and those that are difficult to machine at the lower value. We generally recommend starting with lower values and then optimizing them in practice.

* Detaillierte Schnittwerteeinstellungen, Hartmetallsorten und Beschichtungen sind aus den jeweiligen verwendeten Systemen zu entnehmen (Ultramini, Minicut und DED).

* Take detailed cutting value settings, carbide grades and coatings from the respective systems used (Ultramini, Minicut and DED).

AXALINE

Rotierender Einsteckkopf
für flexible Systemlösungen

rotating grooving head
for flexible system solutions

Impressionen

impressions

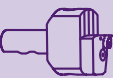
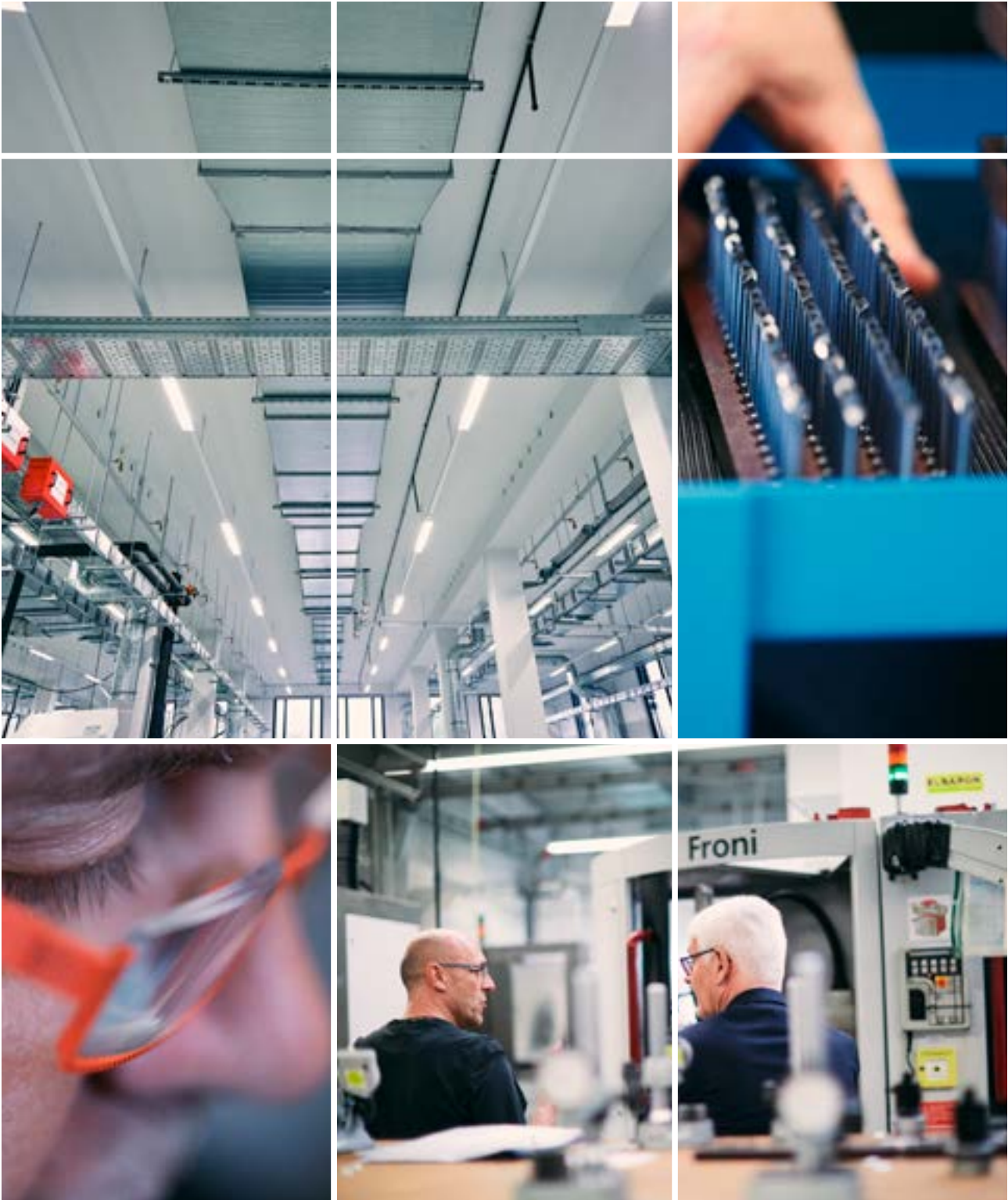

Bohren drilling

Inhalt
content



BM-LINE

BM-LINE

D ≥ Ø 0.8 mm
Bohrungstiefen ≤ 30 x D
Drilling depths ≤ 30 x D

13







BM - LINE

$D \geq \varnothing 0.8 \text{ mm}$

Bohrungstiefen $\leq 30 \times D$

Drilling depths $\leq 30 \times D$

BM-LINE

VHM - Mikrobohrer
mit spiralisierter
Hochleistungskühlung

solid carbide micro drills
with spiralized
high performance cooling

Übersicht

summary



Allgemeine Beschreibung

general instructions

... 3

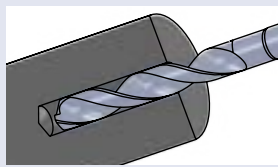

**VHM - Mikrobohrer
mit spiralisierter
Hochleistungskühlung**

**solid carbide micro drills
with spiralized
high performance cooling**

**Maße
dimensions
[mm]**

**Seite
page**

Typ BM05D.135

VHM - Mikrobohrer,
Pilotbohrung 135°
mit spiralisierter
Hochleistungskühlung

solid carbide micro drills,
pilot hole 135°
with spiralized
high performance cooling

D 0.8 - 2.9
Bohrungstiefe/
drilling depth
5xD

... 4

Typ BM08D.128

VHM - Mikrobohrer 128°
mit spiralisierter
Hochleistungskühlung

solid carbide micro drills 128°
with spiralized
high performance cooling

D 0.8 - 2.9
Bohrungstiefe/
drilling depth
8xD

... 6

Typ BM12D.128

VHM - Mikrobohrer 128°
mit spiralisierter
Hochleistungskühlung

solid carbide micro drills 128°
with spiralized
high performance cooling

D 0.8 - 2.9
Bohrungstiefe/
drilling depth
12xD

... 8

Typ BM16D.128

VHM - Mikrobohrer 128°
mit spiralisierter
Hochleistungskühlung

solid carbide micro drills 128°
with spiralized
high performance cooling

D 0.8 - 2.9
Bohrungstiefe/
drilling depth
16xD

... 10

Typ BM20D.128

VHM - Mikrobohrer 128°
mit spiralisierter
Hochleistungskühlung

solid carbide micro drills 128°
with spiralized
high performance cooling

D 0.8 - 2.9
Bohrungstiefe/
drilling depth
20xD

... 12

Typ BM30D.128

VHM - Mikrobohrer 128°
mit spiralisierter
Hochleistungskühlung

solid carbide micro drills 128°
with spiralized
high performance cooling

D 1.0 - 2.9
Bohrungstiefe/
drilling depth
30xD

... 14

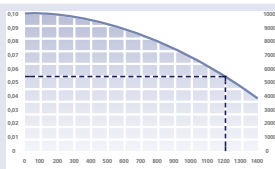

Technische Hinweise

Technical instructions

**Seite
page**

Grundsätzliche Informationen zum
Tieflochbohren mit Pilotbohrung

general informations,
about deep-hole drilling
with pilot hole

... 17

Hartmetallsorten und Beschichtungen

carbide grades and coatings

... 20

Schnittdatenempfehlung

speed and feed recommendation

... 21

BM-LINE

VHM - Mikrobohrer
mit spiralisierter
Hochleistungskühlung

solid carbide micro drills
with spiralized
high performance cooling

Allgemeine Beschreibung

general instruction

Ausspitzung / point geometry

- spezielle Ausspitzung für sicheres Zentrierverhalten
- special point geometry for reliable centring behaviour

Schneidkante / cutting edge

- gleichmäßig und speziell präpariert für optimale Spanform
- evenly and specially prepared for optimum chip shape

Geläppte Oberfläche / lapped surface

- für perfekten Späneabtransport
- for perfect chip evacuation

Spanraumöffnung / chip space opening

- neu entwickelt
- new designed

Durchmesserbereich / diameter range

- 0.8 - 2.9 mm

Beschichtung / coating

- verschleißfeste und extrem glatte AC3N Hochleistungsbeschichtung
- wear-resistant and extremely smooth AC3N high performance coating

Spezielles Substrat / special carbide

- Ultra-Feinkornsubstrat mit 10% Cobalt-Anteil, speziell für die Mikrobearbeitung entwickelt
- ultra-micrograin carbide with 10% cobalt proportion, specially developed for micro-machining



5xD

8xD

12xD

16xD

20xD

30xD

Vorteile

- Höchste Werkzeugpräzision und -stabilität
- Universeller Materialeinsatz mit dem Schwerpunkt Stahlbearbeitung.
- Prozesssicherheit trifft auf Produktivität.

advantages

- maximum tool precision and stability
- for general use on materials, focussing on steel machining
- process reliability meets productivity

- Übergang zu spiralisiertem Kühlkanal
- transition to spiralized coolant hole

- maximal verlängerte Reichweite des vergrößerten Kühlkanalquerschnitts

- maximum extended range of the enlarged coolant hole cross-section

Zentrale Hochleistungskühlung / central high-pressure cooling

- vergrößerter Kühlkanalquerschnitt im gesamten Schaftbereich für verstärkten Durchfluss des Kühlmittels
- höchste Durchflussgeschwindigkeit und optimale Kühlung bei sämtlichen Ausführungen und Größen

- increased coolant hole cross-section over the entire shank area for increased flow of coolant
- maximum flow rate and optimum cooling for all versions and sizes

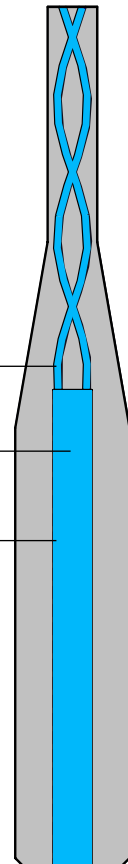

BM-LINE

VHM - Mikrobohrer
mit spiralisierter
Hochleistungskühlung

solid carbide micro drills
with spiralized
high performance cooling

Typ BM05D.135

VHM - Mikrobohrer, Pilotbohrung 135°
mit spiralisierter
Hochleistungskühlung

solig carbide micro drills, pilot hole 135°
with spiralized
high performance cooling

Bohrungsdurchmesser 0.8 - 2.9 mm
Bohrungstiefe ≤ 5xD

drilling diameter from 0.8 - 2.9 mm
drilling depth ≤ 5xD

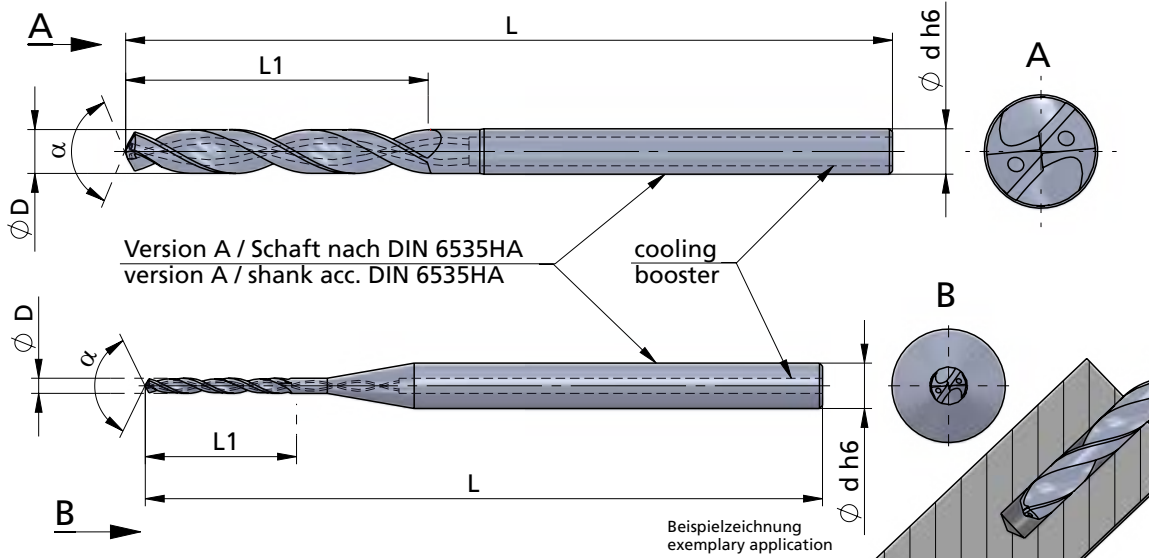

- Pilotbohrer
pilot drill**
- $\alpha \hat{=} 135^\circ$
- Bohrungstiefe
drilling depth
≤ 5xD

Schneidrichtung (R):
wie gezeichnet

cutting direction (R): as shown

Abmessungen in mm

dimensions in mm



Bestellnummer part number	Ø D m6	Ø d h6	L	L1	AC3N
BM0080.05D.135	0.8	3.0	39	5	●
BM0090.05D.135	0.9	3.0	39	6	●
BM0100.05D.135	1.0	3.0	40	7	●
BM0110.05D.135	1.1	3.0	41	7	●
BM0120.05D.135	1.2	3.0	41	8	●
BM0130.05D.135	1.3	3.0	42	9	●
BM0140.05D.135	1.4	3.0	42	9	●
BM0150.05D.135	1.5	3.0	43	10	●
BM0160.05D.135	1.6	3.0	44	11	●
BM0170.05D.135	1.7	3.0	44	11	●
BM0180.05D.135	1.8	3.0	45	12	●
BM0190.05D.135	1.9	3.0	45	13	●
BM0200.05D.135	2.0	3.0	46	14	●
↳ ...					

Bestellbeispiel:
für Sorte AC3N:
BM0080.05D.135/AC3N

order-example:
grade AC3N:
BM0080.05D.135/AC3N

BM-LINE

VHM - Mikrobohrer
mit spiralisierter
Hochleistungskühlung

solid carbide micro drills
with spiralized
high performance cooling

Typ BM05D.135

VHM - Mikrobohrer, Pilotbohrung 135°
mit spiralisierter
Hochleistungskühlung

solig carbide micro drills, pilot hole 135°
with spiralized
high performance cooling

Bohrungsdurchmesser 0.8 - 2.9 mm
Bohrungstiefe $\leq 5xD$

drilling diameter from 0.8 - 2.9 mm
drilling depth $\leq 5xD$

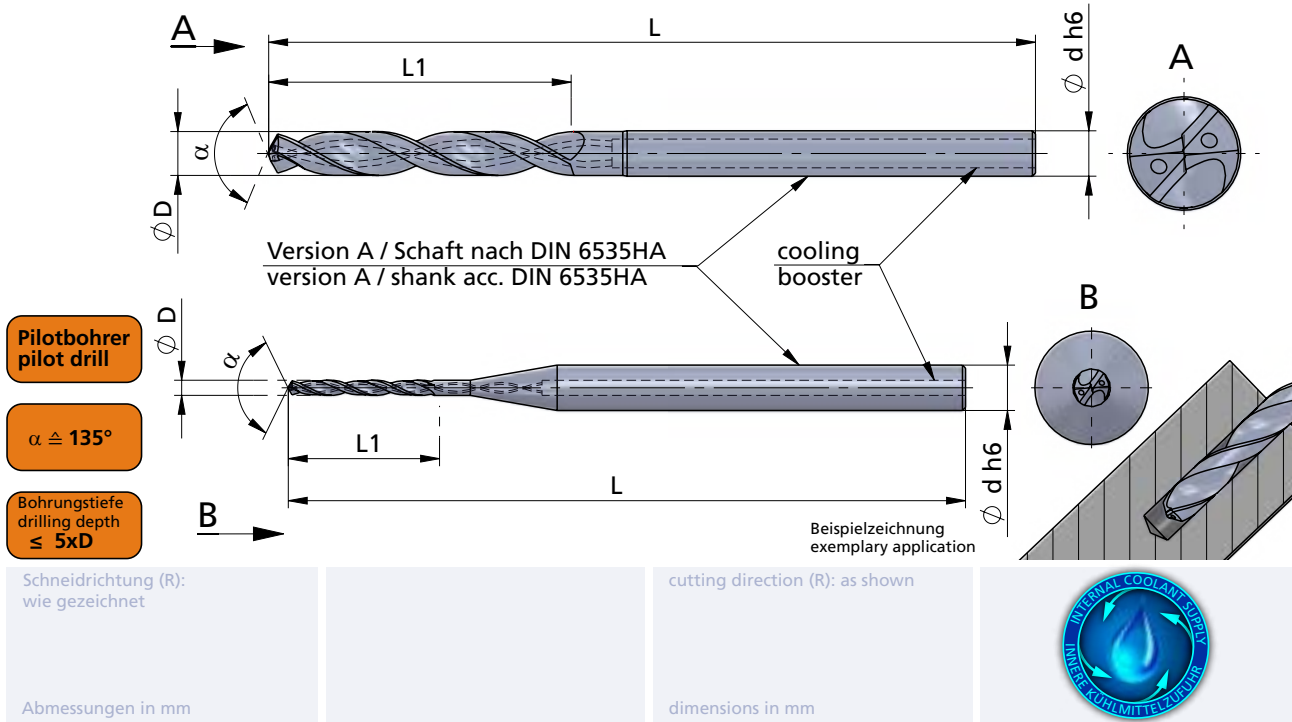

Bestellnummer part number	$\varnothing D$ m6	$\varnothing d$ h6	L	L1	AC3N
...					
BM0210.05D.135	2.1	3.0	47	14	●
BM0220.05D.135	2.2	3.0	47	15	●
BM0230.05D.135	2.3	3.0	48	16	●
BM0240.05D.135	2.4	3.0	48	16	●
BM0250.05D.135	2.5	3.0	49	17	●
BM0260.05D.135	2.6	3.0	50	18	●
BM0270.05D.135	2.7	3.0	50	18	●
BM0280.05D.135	2.8	3.0	51	19	●
BM0290.05D.135	2.9	3.0	51	20	●

Bestellbeispiel:
für Sorte AC3N:
BM0210.05D.135/AC3N

order-example:
grade AC3N:
BM0210.05D.135/AC3N

BM-LINE

VHM - Mikrobohrer
mit spiralisierter
Hochleistungskühlung

solid carbide micro drills
with spiralized
high performance cooling

Typ BM08D.128

VHM - Mikrobohrer 128°
mit spiralisierter
Hochleistungskühlung

solig carbide micro drills 128°
with spiralized
high performance cooling

Bohrungsdurchmesser 0.8 - 2.9 mm
Bohrungstiefe ≤ 8xD

drilling diameter from 0.8 - 2.9 mm
drilling depth ≤ 8xD

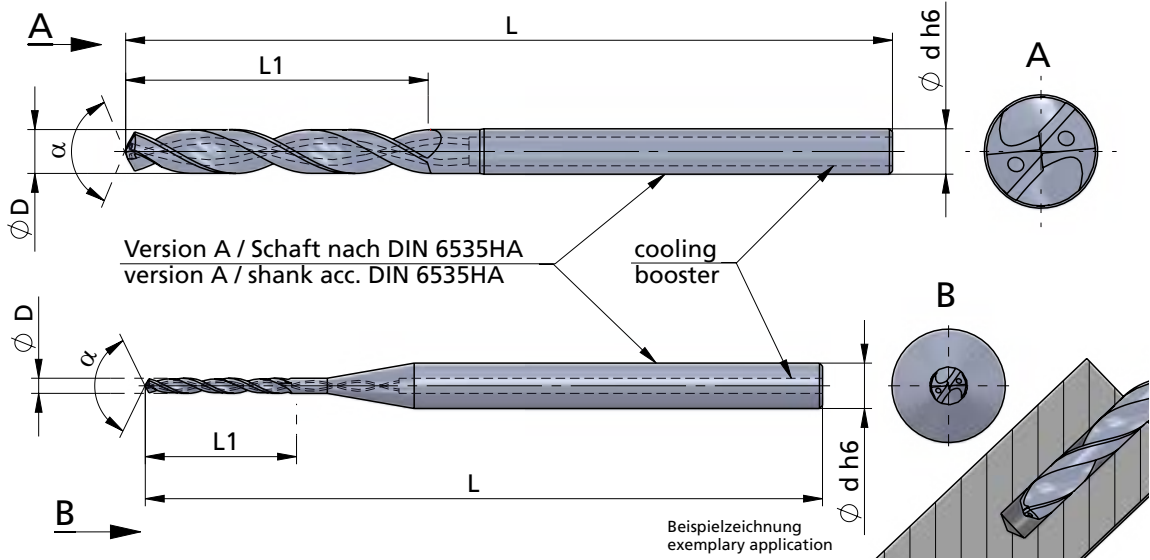

$\alpha \hat{=} 128^\circ$

Bohrungstiefe
drilling depth
≤ 8xD

Schneidrichtung (R):
wie gezeichnet

cutting direction (R): as shown

Abmessungen in mm

dimensions in mm



Bestellnummer part number	Ø D h6	Ø d h6	L	L1	AC3N
BM0080.08D.128	0.8	3.0	41	8	●
BM0090.08D.128	0.9	3.0	42	9	●
BM0100.08D.128	1.0	3.0	43	10	●
BM0110.08D.128	1.1	3.0	44	11	●
BM0120.08D.128	1.2	3.0	45	12	●
BM0130.08D.128	1.3	3.0	46	13	●
BM0140.08D.128	1.4	3.0	47	14	●
BM0150.08D.128	1.5	3.0	47	15	●
BM0160.08D.128	1.6	3.0	48	16	●
BM0170.08D.128	1.7	3.0	49	17	●
BM0180.08D.128	1.8	3.0	50	18	●
BM0190.08D.128	1.9	3.0	51	19	●
BM0200.08D.128	2.0	3.0	52	20	●
↳ ...					

BM-LINE

VHM - Mikrobohrer
mit spiralisierter
Hochleistungskühlung

solid carbide micro drills
with spiralized
high performance cooling

Typ BM08D.128

VHM - Mikrobohrer 128°
mit spiralisierter
Hochleistungskühlung

solig carbide micro drills 128°
with spiralized
high performance cooling

Bohrungsdurchmesser 0.8 - 2.9 mm
Bohrungstiefe ≤ 8xD

drilling diameter from 0.8 - 2.9 mm
drilling depth ≤ 8xD

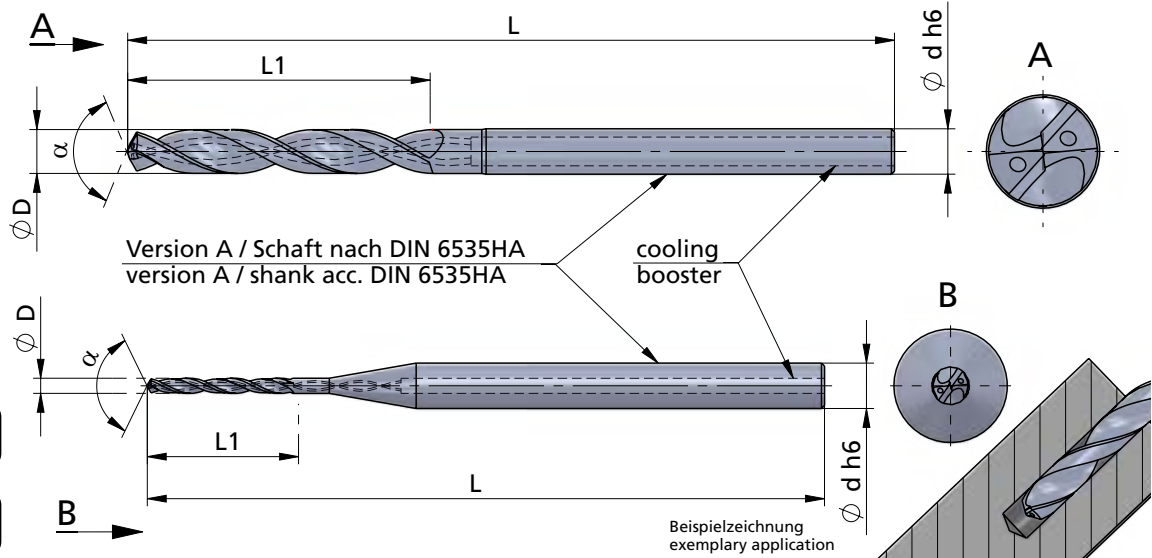

$\alpha \hat{=} 128^\circ$

Bohrungstiefe
drilling depth
≤ 8xD

Schneidrichtung (R):
wie gezeichnet

cutting direction (R): as shown

Abmessungen in mm

dimensions in mm



Bestellnummer part number	Ø D h6	Ø d h6	L	L1	AC3N
...					
BM0210.08D.128	2.1	3.0	53	21	●
BM0220.08D.128	2.2	3.0	54	22	●
BM0230.08D.128	2.3	3.0	55	23	●
BM0240.08D.128	2.4	3.0	56	24	●
BM0250.08D.128	2.5	3.0	56	25	●
BM0260.08D.128	2.6	3.0	57	26	●
BM0270.08D.128	2.7	3.0	58	27	●
BM0280.08D.128	2.8	3.0	59	28	●
BM0290.08D.128	2.9	3.0	60	29	●

Bestellbeispiel:
für Sorte AC3N:
BM0210.08D.128/AC3N

order-example:
grade AC3N:
BM0210.08D.128/AC3N

BM-LINE

VHM - Mikrobohrer
mit spiralisierter
Hochleistungskühlung

solid carbide micro drills
with spiralized
high performance cooling

Typ BM12D.128

VHM - Mikrobohrer 128°
mit spiralisierter
Hochleistungskühlung

solig carbide micro drills 128°
with spiralized
high performance cooling

Bohrungsdurchmesser 0.8 - 2.9 mm
Bohrungstiefe ≤ 12xD

drilling diameter from 0.8 - 2.9 mm
drilling depth ≤ 12xD

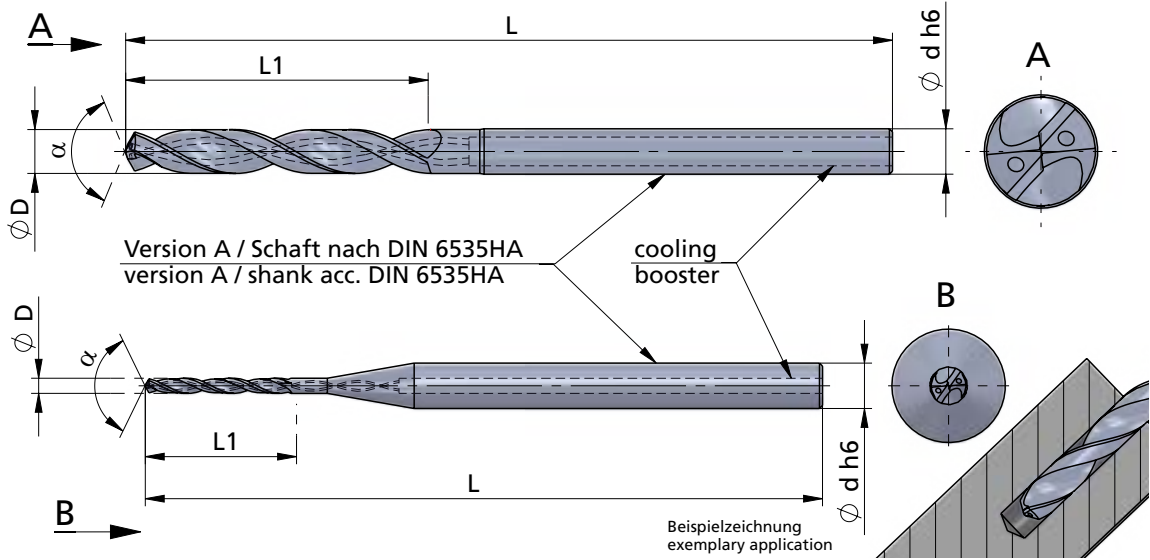

$\alpha \hat{=} 128^\circ$

Bohrungstiefe
drilling depth
≤ 12xD

Schneidrichtung (R):
wie gezeichnet

cutting direction (R): as shown

Abmessungen in mm

dimensions in mm



Bestellnummer part number	Ø D h6	Ø d h6	L	L1	AC3N
BM0080.12D.128	0.8	3.0	44	11	●
BM0090.12D.128	0.9	3.0	46	13	●
BM0100.12D.128	1.0	3.0	47	14	●
BM0110.12D.128	1.1	3.0	48	15	●
BM0120.12D.128	1.2	3.0	50	17	●
BM0130.12D.128	1.3	3.0	51	18	●
BM0140.12D.128	1.4	3.0	52	20	●
BM0150.12D.128	1.5	3.0	53	21	●
BM0160.12D.128	1.6	3.0	55	22	●
BM0170.12D.128	1.7	3.0	56	24	●
BM0180.12D.128	1.8	3.0	57	25	●
BM0190.12D.128	1.9	3.0	59	27	●
BM0200.12D.128	2.0	3.0	60	28	●
↳ ...					

BM-LINE

VHM - Mikrobohrer
mit spiralisierter
Hochleistungskühlung

solid carbide micro drills
with spiralized
high performance cooling

Typ BM12D.128

VHM - Mikrobohrer 128°
mit spiralisierter
Hochleistungskühlung

solig carbide micro drills 128°
with spiralized
high performance cooling

Bohrungsdurchmesser 0.8 - 2.9 mm
Bohrungstiefe ≤ 12xD

drilling diameter from 0.8 - 2.9 mm
drilling depth ≤ 12xD

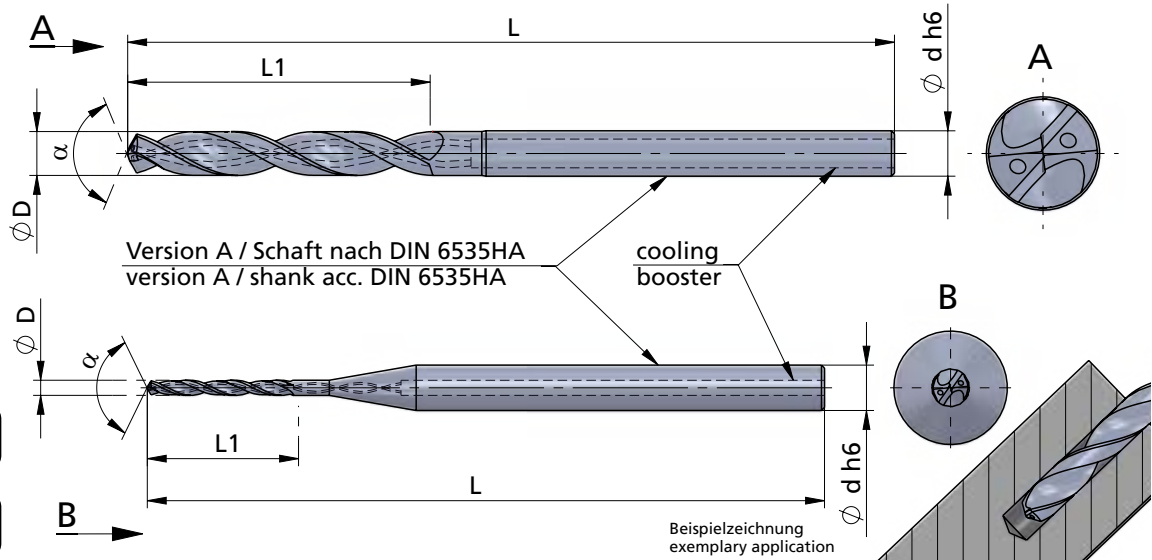

$\alpha \hat{=} 128^\circ$

Bohrungstiefe
drilling depth
≤ 12xD

Schneidrichtung (R):
wie gezeichnet

cutting direction (R): as shown

Abmessungen in mm

dimensions in mm



Bestellnummer part number	Ø D h6	Ø d h6	L	L1	AC3N
...					
BM0210.12D.128	2.1	3.0	61	29	●
BM0220.12D.128	2.2	3.0	63	31	●
BM0230.12D.128	2.3	3.0	64	32	●
BM0240.12D.128	2.4	3.0	65	34	●
BM0250.12D.128	2.5	3.0	67	35	●
BM0260.12D.128	2.6	3.0	68	36	●
BM0270.12D.128	2.7	3.0	69	38	●
BM0280.12D.128	2.8	3.0	70	39	●
BM0290.12D.128	2.9	3.0	72	41	●

Bestellbeispiel:
für Sorte AC3N:
BM0210.12D.128/AC3N

order-example:
grade AC3N:
BM0210.12D.128/AC3N

BM-LINE

VHM - Mikrobohrer
mit spiralisierter
Hochleistungskühlung

solid carbide micro drills
with spiralized
high performance cooling

Typ BM16D.128

VHM - Mikrobohrer 128°
mit spiralisierter
Hochleistungskühlung

solig carbide micro drills 128°
with spiralized
high performance cooling

Bohrungsdurchmesser 0.8 - 2.9 mm
Bohrungstiefe ≤ 16xD

drilling diameter from 0.8 - 2.9 mm
drilling depth ≤ 16xD

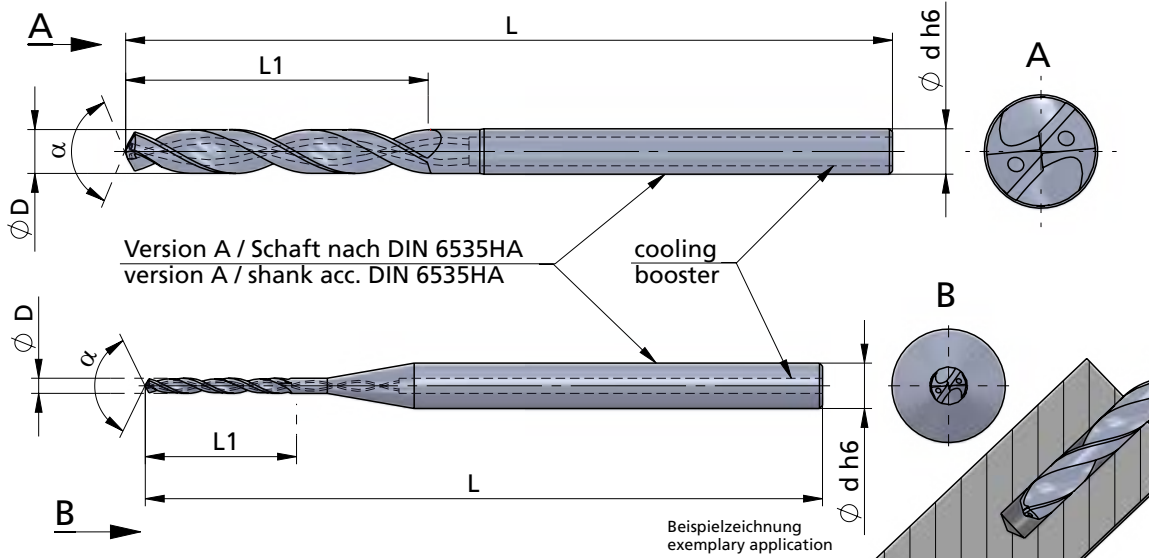

$\alpha \hat{=} 128^\circ$
Bohrungstiefe
drilling depth
≤ 16xD

Schneidrichtung (R):
wie gezeichnet

cutting direction (R): as shown

Abmessungen in mm

dimensions in mm



Bestellnummer part number	Ø D h6	Ø d h6	L	L1	AC3N
BM0080.16D.128	0.8	3.0	48	14	●
BM0090.16D.128	0.9	3.0	49	16	●
BM0100.16D.128	1.0	3.0	51	18	●
BM0110.16D.128	1.1	3.0	53	20	●
BM0120.16D.128	1.2	3.0	54	22	●
BM0130.16D.128	1.3	3.0	56	23	●
BM0140.16D.128	1.4	3.0	58	25	●
BM0150.16D.128	1.5	3.0	60	27	●
BM0160.16D.128	1.6	3.0	61	29	●
BM0170.16D.128	1.7	3.0	63	31	●
BM0180.16D.128	1.8	3.0	65	32	●
BM0190.16D.128	1.9	3.0	66	34	●
BM0200.16D.128	2.0	3.0	68	36	●
↳ ...					

BM-LINE

VHM - Mikrobohrer
mit spiralisierter
Hochleistungskühlung

solid carbide micro drills
with spiralized
high performance cooling

Typ BM16D.128

VHM - Mikrobohrer 128°
mit spiralisierter
Hochleistungskühlung

solig carbide micro drills 128°
with spiralized
high performance cooling

Bohrungsdurchmesser 0.8 - 2.9 mm
Bohrungstiefe ≤ 16xD

drilling diameter from 0.8 - 2.9 mm
drilling depth ≤ 16xD

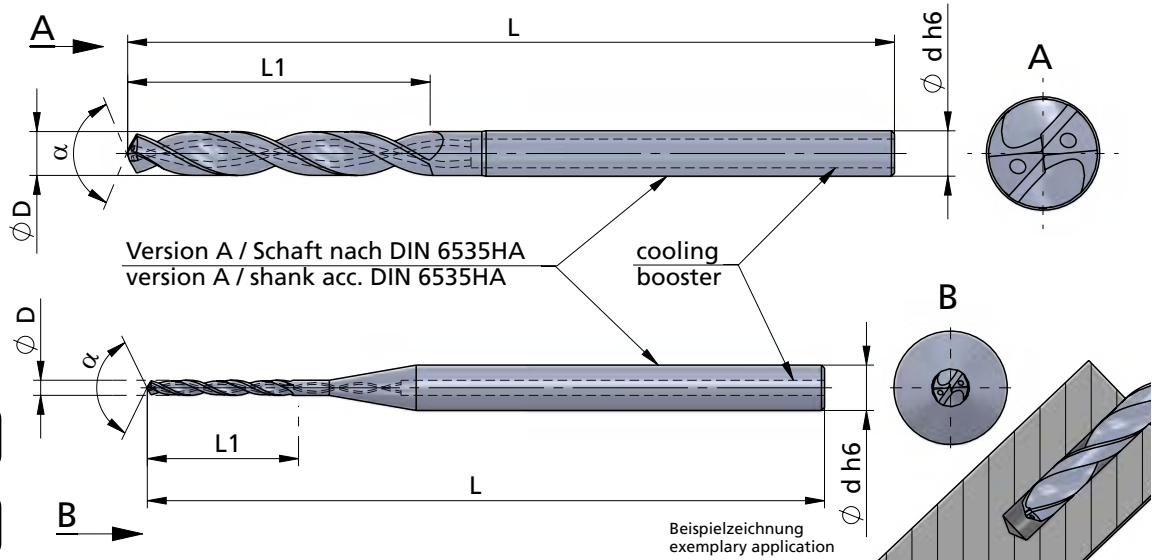

$\alpha \hat{=} 128^\circ$

Bohrungstiefe
drilling depth
≤ 16xD

Schneidrichtung (R):
wie gezeichnet

cutting direction (R): as shown

Abmessungen in mm

dimensions in mm



Bestellnummer part number	Ø D h6	Ø d h6	L	L1	AC3N
...					
BM0210.16D.128	2.1	3.0	70	38	●
BM0220.16D.128	2.2	3.0	71	40	●
BM0230.16D.128	2.3	3.0	73	41	●
BM0240.16D.128	2.4	3.0	75	43	●
BM0250.16D.128	2.5	3.0	77	45	●
BM0260.16D.128	2.6	3.0	78	47	●
BM0270.16D.128	2.7	3.0	80	49	●
BM0280.16D.128	2.8	3.0	82	50	●
BM0290.16D.128	2.9	3.0	83	52	●

Bestellbeispiel:
für Sorte AC3N:
BM0210.16D.128/AC3N

order-example:
grade AC3N:
BM0210.16D.128/AC3N

BM-LINE

VHM - Mikrobohrer
mit spiralisierter
Hochleistungskühlung

solid carbide micro drills
with spiralized
high performance cooling

Typ BM20D.128

VHM - Mikrobohrer 128°
mit spiralisierter
Hochleistungskühlung

solig carbide micro drills 128°
with spiralized
high performance cooling

Bohrungsdurchmesser 0.8 - 2.9 mm
Bohrungstiefe ≤ 20xD

drilling diameter from 0.8 - 2.9 mm
drilling depth ≤ 20xD

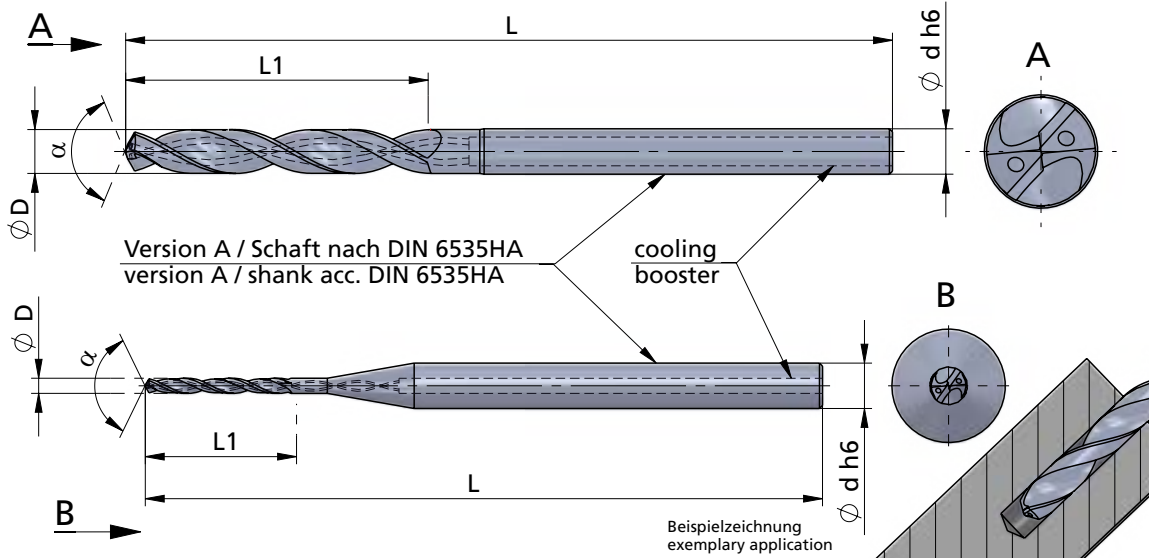

$\alpha \hat{=} 128^\circ$

Bohrungstiefe
drilling depth
≤ 20xD

Schneidrichtung (R):
wie gezeichnet

cutting direction (R): as shown

Abmessungen in mm

dimensions in mm



Bestellnummer
part number

Ø D h6

Ø d h6

L

L1

AC3N

BM0080.20D.128	0.8	3.0	51	18	●
BM0090.20D.128	0.9	3.0	53	20	●
BM0100.20D.128	1.0	3.0	55	22	●
BM0110.20D.128	1.1	3.0	57	24	●
BM0120.20D.128	1.2	3.0	59	26	●
BM0130.20D.128	1.3	3.0	61	29	●
BM0140.20D.128	1.4	3.0	63	31	●
BM0150.20D.128	1.5	3.0	66	33	●
BM0160.20D.128	1.6	3.0	68	35	●
BM0170.20D.128	1.7	3.0	70	37	●
BM0180.20D.128	1.8	3.0	72	40	●
BM0190.20D.128	1.9	3.0	74	42	●
BM0200.20D.128	2.0	3.0	76	44	●

↳ ...

BM-LINE

VHM - Mikrobohrer
mit spiralisierter
Hochleistungskühlung

solid carbide micro drills
with spiralized
high performance cooling

Typ BM20D.128

VHM - Mikrobohrer 128°
mit spiralisierter
Hochleistungskühlung

solig carbide micro drills 128°
with spiralized
high performance cooling

Bohrungsdurchmesser 0.8 - 2.9 mm
Bohrungstiefe ≤ 20xD

drilling diameter from 0.8 - 2.9 mm
drilling depth ≤ 20xD

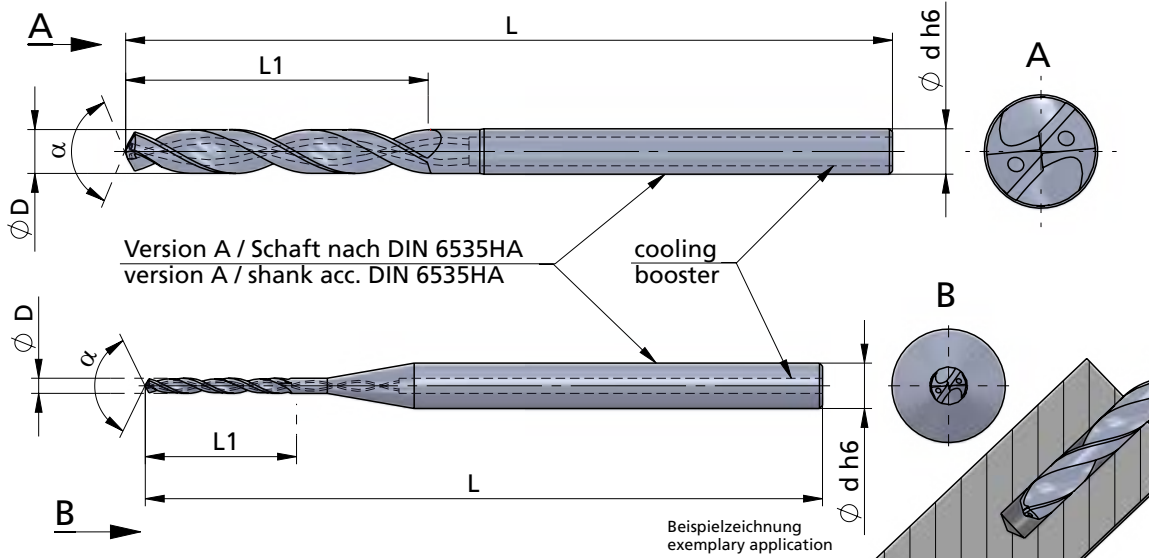

$\alpha \hat{=} 128^\circ$

Bohrungstiefe
drilling depth
≤ 20xD

Schneidrichtung (R):
wie gezeichnet

cutting direction (R): as shown

Abmessungen in mm

dimensions in mm



Bestellnummer part number	Ø D h6	Ø d h6	L	L1	AC3N
...					
BM0210.20D.128	2.1	3.0	78	46	●
BM0220.20D.128	2.2	3.0	80	48	●
BM0230.20D.128	2.3	3.0	82	51	●
BM0240.20D.128	2.4	3.0	85	53	●
BM0250.20D.128	2.5	3.0	87	55	●
BM0260.20D.128	2.6	3.0	89	57	●
BM0270.20D.128	2.7	3.0	91	59	●
BM0280.20D.128	2.8	3.0	93	62	●
BM0290.20D.128	2.9	3.0	95	64	●

Bestellbeispiel:
für Sorte AC3N:
BM0210.20D.128/AC3N

order-example:
grade AC3N:
BM0210.20D.128/AC3N

BM-LINE

VHM - Mikrobohrer
mit spiralisierter
Hochleistungskühlung

solid carbide micro drills
with spiralized
high performance cooling

Typ BM30D.128

VHM - Mikrobohrer 128°
mit spiralisierter
Hochleistungskühlung

solig carbide micro drills 128°
with spiralized
high performance cooling

Bohrungsdurchmesser 1.0 - 2.9 mm
Bohrungstiefe ≤ 30xD

drilling diameter from 1.0 - 2.9 mm
drilling depth ≤ 30xD

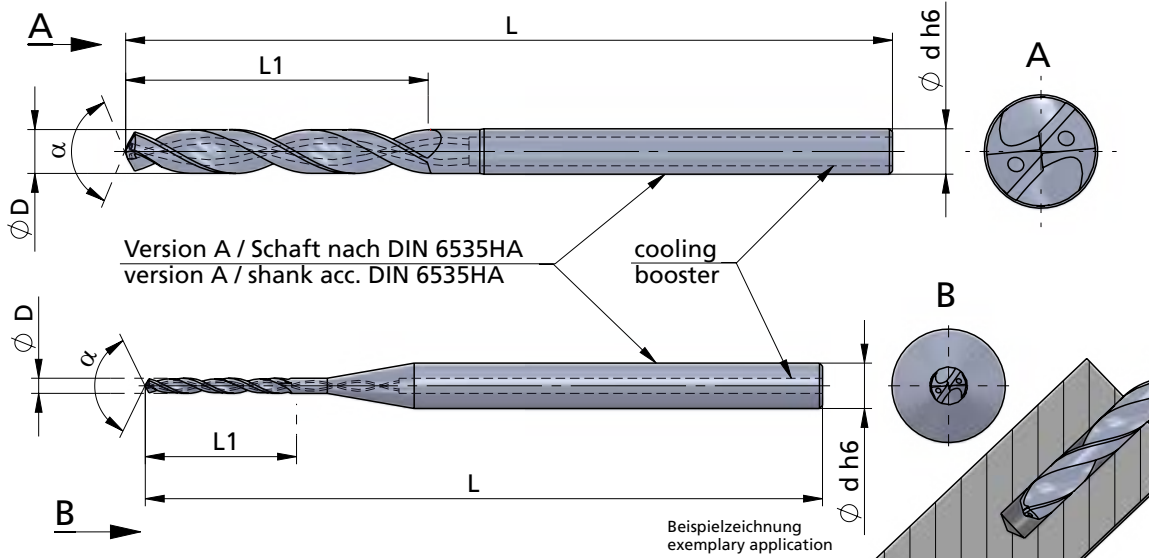

$\alpha \hat{=} 128^\circ$
Bohrungstiefe
drilling depth
≤ 30xD

Schneidrichtung (R):
wie gezeichnet

cutting direction (R): as shown

Abmessungen in mm

dimensions in mm



Bestellnummer part number	Ø D h6	Ø d h6	L	L1	AC3N
BM0100.30D.128	1.0	3.0	65	32	●
BM0110.30D.128	1.1	3.0	68	35	●
BM0120.30D.128	1.2	3.0	71	38	●
BM0130.30D.128	1.3	3.0	74	41	●
BM0140.30D.128	1.4	3.0	78	44	●
BM0150.30D.128	1.5	3.0	81	48	●
BM0160.30D.128	1.6	3.0	84	51	●
BM0170.30D.128	1.7	3.0	87	54	●
BM0180.30D.128	1.8	3.0	90	57	●
BM0190.30D.128	1.9	3.0	93	60	●
BM0200.30D.128	2.0	3.0	96	64	●
↳ ...					

BM-LINE

VHM - Mikrobohrer
mit spiralisierter
Hochleistungskühlung

solid carbide micro drills
with spiralized
high performance cooling

Typ BM30D.128

VHM - Mikrobohrer 128°
mit spiralisierter
Hochleistungskühlung

solig carbide micro drills 128°
with spiralized
high performance cooling

Bohrungsdurchmesser 1.0 - 2.9 mm
Bohrungstiefe ≤ 30xD

drilling diameter from 1.0 - 2.9 mm
drilling depth ≤ 30xD

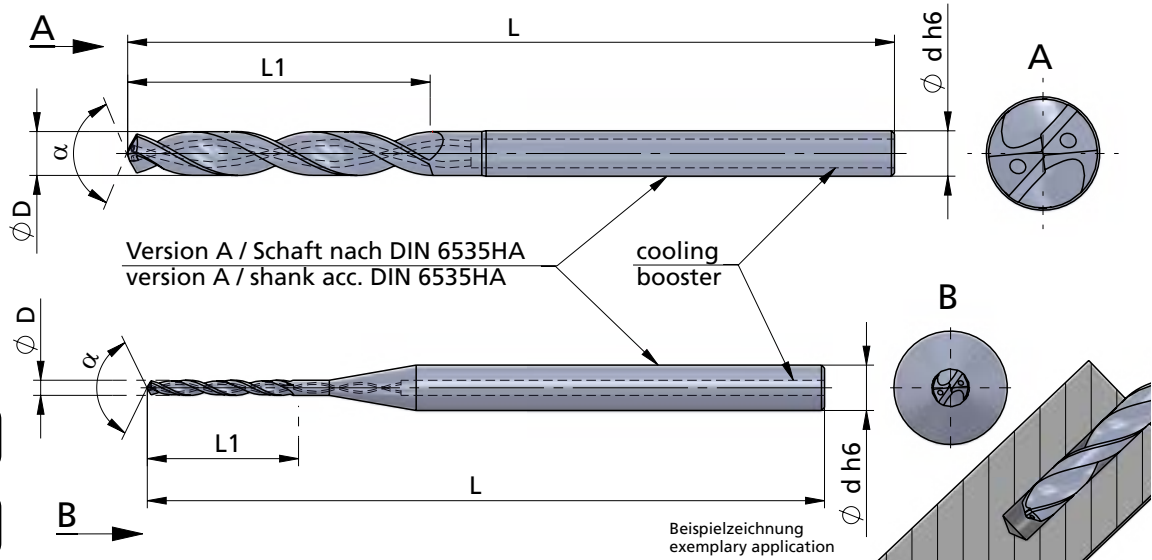

$\alpha \hat{=} 128^\circ$

Bohrungstiefe
drilling depth
≤ 30xD

Schneidrichtung (R):
wie gezeichnet

cutting direction (R): as shown

Abmessungen in mm

dimensions in mm



Bestellnummer part number	Ø D h6	Ø d h6	L	L1	AC3N
...					
BM0210.30D.128	2.1	3.0	99	67	●
BM0220.30D.128	2.2	3.0	102	70	●
BM0230.30D.128	2.3	3.0	106	73	●
BM0240.30D.128	2.4	3.0	109	76	●
BM0250.30D.128	2.5	3.0	112	80	●
BM0260.30D.128	2.6	3.0	115	83	●
BM0270.30D.128	2.7	3.0	118	86	●
BM0280.30D.128	2.8	3.0	121	89	●
BM0290.30D.128	2.9	3.0	124	92	●

Bestellbeispiel:
für Sorte AC3N:
BM0210.30D.128/AC3N

order-example:
grade AC3N:
BM0210.30D.128/AC3N

BM-LINE

VHM - Mikrobohrer
mit spiralisierter
Hochleistungskühlung

solid carbide micro drills
with spiralized
high performance cooling

Impressionen

impressions



BM-LINE

VHM - Mikrobohrer
mit spiralisierter
Hochleistungskühlung

solid carbide micro drills
with spiralized
high performance cooling

Technische Hinweise

Grundsätzliche Informationen
zum Tieflochbohren mit Pilotbohrung

Technical instructions,
general informations about deep-hole drilling
with pilot hole

Anwendungsempfehlung:

- Die vorbereitete Pilotbohrung muss frei von Spänen sein, um ein Aufsitzen der Schneide (Mikrotieflochbohrer) zu vermeiden
- Bei vertikaler Bearbeitung von regelmäßigen und geraden Oberflächen kann ab einem Ø1.0mm bis zu einer Länge von 12xD auf eine Pilotbohrung verzichtet werden, aufgrund der hervorragenden Eigenzentrierung. Bei horizontaler Bearbeitung oder unregelmäßigen und schrägen Oberflächen muss ein Pilotbohrer verwendet werden.
- Um ein problemloses Einführen des Tieflochbohrers in die Pilotbohrung zu garantieren, wird bei horizontaler Bearbeitung eine 90° Senkung mit entsprechend geeignetem NC-Senker empfohlen.
- Bei vertikaler Bearbeitung können Bohrer ab Ø1.0mm bis zu einer Länge von 12xD auch ohne Drehzahlreduzierung außerhalb der Pilotbohrung betrieben werden.
- Bei Durchgangsbohrungen ist der Vorschub pro Umdrehung vor dem Bohrungsaustritt um 50% zu reduzieren.
- Bei langspanenden Materialien kann ab einer Bohrtiefe von 10xD ein Entspannen alle 3xD erforderlich sein. Die Entspannungshubbewegung (Rückzugbewegung) soll auf Pilotbohrungstiefe erfolgen.
- Aufgrund der kleinen IKØ bei Mikrobohrern ist auf eine effektive Filtration des Kühlmediums unbedingt Wert zu legen.
Bohrer < Ø2.0mm Filter ≤ 0.01mm
Bohrer < Ø3.0mm Filter ≤ 0.02mm
- Schweb- und Kleinstpartikel im Kühlmedium verhindern mit zunehmendem Alter der Emulsion einen effektiven Kühlfluss. Regelmäßiger Kühlmitteltausch wird deshalb empfohlen.
- Zur Prozesssicheren Fertigung ist ein geeignetes Spannmittel mit höchsten Rundlaufgenauigkeiten und Wuchtgüte erforderlich.
Rundlaufgenauigkeit ≤ 0.003mm
Eignung für hohe Drehzahlbereiche
- Um einen Prozesssicheren Bohrvorgang zu garantieren, muss ein Mindestkühlmitteldruck von 30 bis max. 50 bar vorhanden sein.

Recommended application

- The prepared pilot hole must be free of chips to avoid rest on of the cutting edges.
- During vertical machining, a pilot hole is not required for regular and straight surfaces from Ø1.0mm up to a length of 12xD due to the excellent self-centring. During horizontal drilling, a pilot drill must be used for irregular and angled surfaces.
- To guarantee problem-free insertion of the deep hole twist drill in the pilot hole, during horizontal machining 90° countersinking with suitable NC countersink is recommended.
- During vertical machining, drills from Ø1.0mm up to a length of 12xD can also be operated outside the pilot hole without a reduction in speed.
- For through holes, the feed per revolution must be reduced by 50% before exiting the hole.
- For long-chipping materials, pecking may be required every 3xD from a hole depth of 10xD. Peck drilling (retraction) should occur at the pilot hole depth.
- Due to the small through coolant Ø during micro drilling, effective filtration of the cooling medium is of the utmost importance.
Drill < Ø2.0mm filter ≤ 0.01mm
Drill < Ø3.0mm filter ≤ 0.02mm
- The longer the coolant is in the machine, suspended particles and particulate matter in the cooling medium prevent effective coolant flow. Regular replacement of the coolant is therefore recommended.
- A suitable clamping device with max. radial run-out accuracy and balance quality is required for process-secure production.
Radial run-out accuracy ≤ 0.003mm
Suitable for high-speed applications
- To guarantee a process-secure drilling process, a minimum cooling pressure of 30 up to max. 50 bar must be present.



BM-LINE

VHM - Mikrobohrer
mit spiralisierter
Hochleistungskühlung

solid carbide micro drills
with spiralized
high performance cooling

Technische Hinweise

Grundsätzliche Informationen
zum Tieflochbohren mit Pilotbohrung

Technical instructions,
general informations about deep-hole drilling
with pilot hole

1 Pilotbohrung setzen / producing the pilot hole

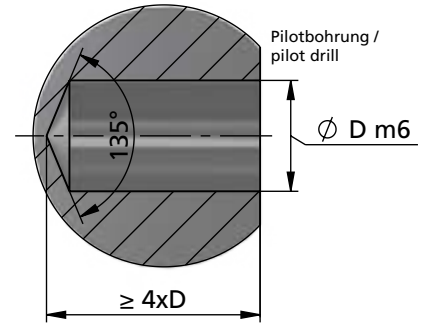
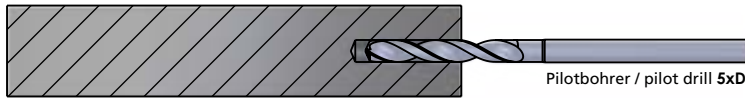

- für die Pilotbohrung 5xD - Bohrer bei gleichem Nenndurchmesser verwenden
- ab 16xD Bohrtiefe ist eine Pilotbohrung Voraussetzung
- Pilotbohrung muss spänefrei sein
- Kühlmitteldruck: 30 bis max. 50 bar
- Kühlmittel filtrieren
- max. Nutzlänge beachten

- we recommend to use for the pilot hole a 5xD - drill, with the same nominal diameter
- from a drilling depth of 16xD a pilot hole is a prerequisite
- ensure the pilot hole is clean
- coolant pressure: 30 up to max. 50 bar
- filtration of the coolant
- observe the maximum usable length

2 Eintritt in die Pilotbohrung mit Tieflochbohrer / entering the pilot hole with a deep hole twist drill

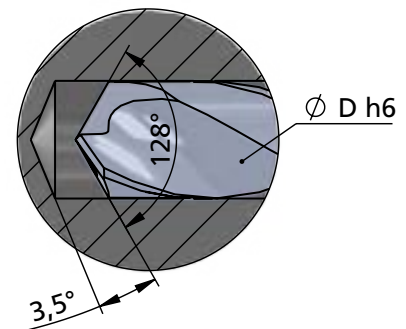
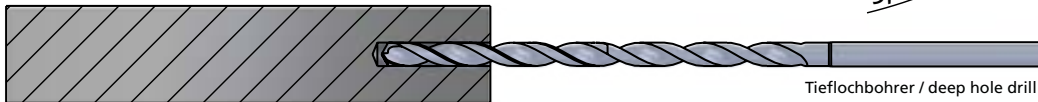

- ohne Kühlmittel eintauchen
- geringe Drehzahl (200 - 300 U/min)
- Eintrittsvorschub ca. 1000 mm/min
- 0.5-2.0mm vor Erreichen des Pilotgrundes Vorschub stoppen
- Kühlung einschalten
- erhöhen auf empfohlene Drehzahl
- verweilen, bis Parameter erreicht sind

- entry without cooling
- reduced speed (200-300 rpm)
- entry feed approx. 1000 mm/min
- 0.5-2.0mm before reaching the bore bottom stop the feed
- switch on cooling
- increase to the recommended speed
- stay until the parameters are reached

BM-LINE

VHM - Mikrobohrer
mit spiralisierter
Hochleistungskühlung

solid carbide micro drills
with spiralized
high performance cooling

Technische Hinweise

Grundsätzliche Informationen
zum Tieflochbohren mit Pilotbohrung

Technical instructions,
general informations about deep-hole drilling
with pilot hole



3 Tieflochbohren / deep hole drilling

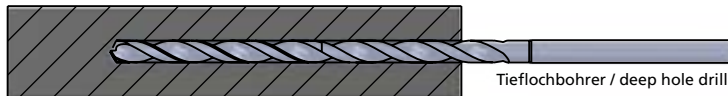

- auf Bohrtiefe fahren ohne Entspannen
- bei langspanenden Materialien kann ein Entspannen erforderlich sein
- bei Materialaustritt oder Querbohrungen Vorschub um -50% reduzieren
- drive to the hole depth without pecking
- at long chipping materials pecking is maybe necessary
- when exiting material or cross hole exists reduce feed rate by -50%

4 Herausfahren des Bohrers / retracting the drill



- Bohrer ca. 1xD zurückziehen
- Drehzahl auf 200-300 U/min verringern
- Austrittsvorschub ca. 1000 mm/min
- Kühlmittel vor dem Verlassen der Bohrung ausschalten
- retract drill approx. 1xD
- reduce speed to 200-300 rpm
- exit feed approx. 1000 mm/min
- switch off cooling before exiting the hole

BM-LINE

VHM - Mikrobohrer
mit spiralisierter
Hochleistungskühlung

solid carbide micro drills
with spiralized
high performance cooling

Technische Hinweise

Hartmetallsorten und Beschichtungen

Technical instructions,
carbide grades and coatings



AC3N

Extrem glatte und verschleißfeste AlCrN-Hochleistungs-Beschichtung speziell für Mikrowerkzeuge für den universellen Einsatz bis max. 32HRC.

Extremely smooth and wear-resistant AlCrN high-performance coating especially for micro tools for universal use up to max. 32HRC.

BM-LINE

VHM - Mikrobohrer
mit spiralisierter
Hochleistungskühlung

solid carbide micro drills
with spiralized
high performance cooling

Technische Hinweise

Schnittdatenempfehlung

Technical instructions,
speed and feed recommendation

V_c (m/min)

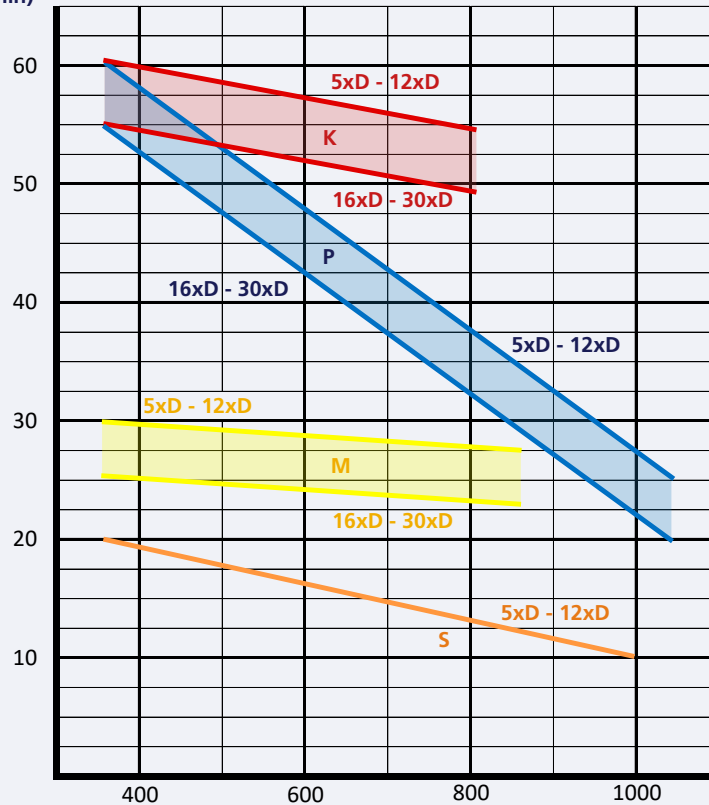

Zugfestigkeit /
tensile strength (N/mm²)

P M K S

Werkstoffgruppen/
material groups

f (mm/U)

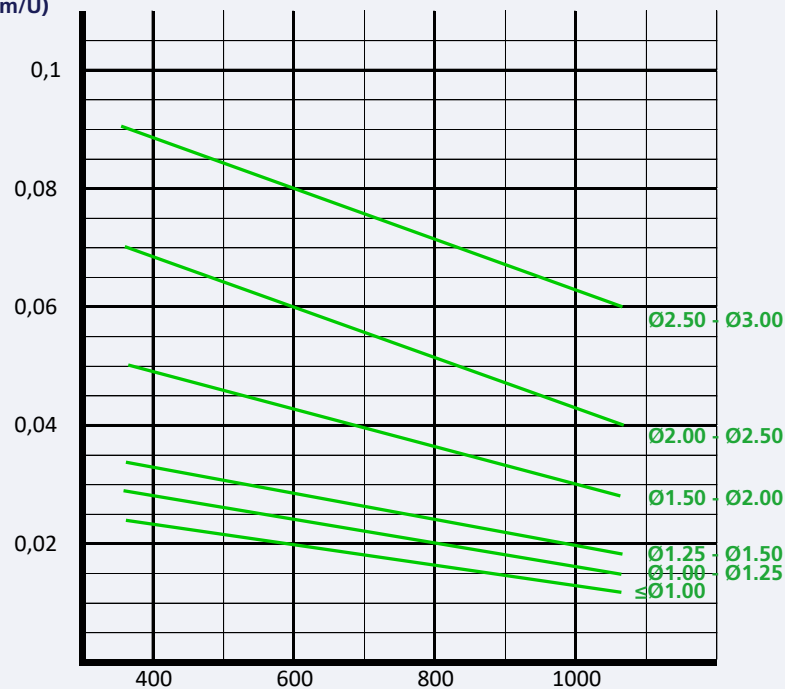

Zugfestigkeit /
tensile strength (N/mm²)



Notiz

notice



A large area for taking notes, consisting of multiple horizontal rows of dotted lines on a white background.

Notiz

notice



Notiz

notice



Notiz

notice



Notiz

notice



Notiz

notice





25 Jahre

Dümmel WERKZEUGFABRIK

Zertifiziert nach / certified to
DIN EN ISO 9001: 2015

MINDESTBESTELLMENGE
für Schneidplatten beträgt
die Mindestbestellmenge
2 Stück, für Halter 1 Stück.

MINIMUM ORDER QUANTITY
for inserts the minimum order
quantity is 2 pieces,
for toolholders 1 piece.

MINDESTBESTELLWERT
der Mindestbestellwert pro
Auftrag beträgt € 80,- Netto
(ausschließlich Umsatzsteuer).
Für Aufträge unter € 80,-
berechnen wir einen Zuschlag
für Kleinaufträge in Höhe
von € 20,-.

MINIMUM ORDER VALUE
the minimum order value for
one order is € 80,- net.
(excluded sales tax).
For orders less than € 80,-
we have an additional order
charge of € 20,-.

© Stand 09/2024
Urheberrechtlich geschützt.

© edition 09/2024
copyright reserved.

Katalognachdruck oder
Veröffentlichung auch
auszugsweise verboten.

reprint or publishing of the
catalogue complete or in
extracts prohibited.

Technische Änderungen und
Irrtümer vorbehalten, keine
Gewährleistung für
Druckfehler.

technical changes and errors
reserved, no warranty for
missprints.

