

Hydrodehnspannfutter Hydraulic chuck

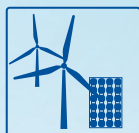

ERNEUERBARE
ENERGIEEN
RENEWABLE
ENERGY



ALLGEMEINER
MASCHINENBAU
GENERAL
MECHANICAL
ENGINEERING



AUTOMOTIVE
AUTOMOTIVE



ELEKTRONIK
ELECTRONICS



OPTIK
OPTICS



FEINMECHANIK
FINE MECHANICS



WERKZEUGBAU
TOOLMAKING

HC... HSK-A, DIN 69893-1

Schaft HSK-A nach DIN 69893-1 HSK-A shank according to DIN 69893-1

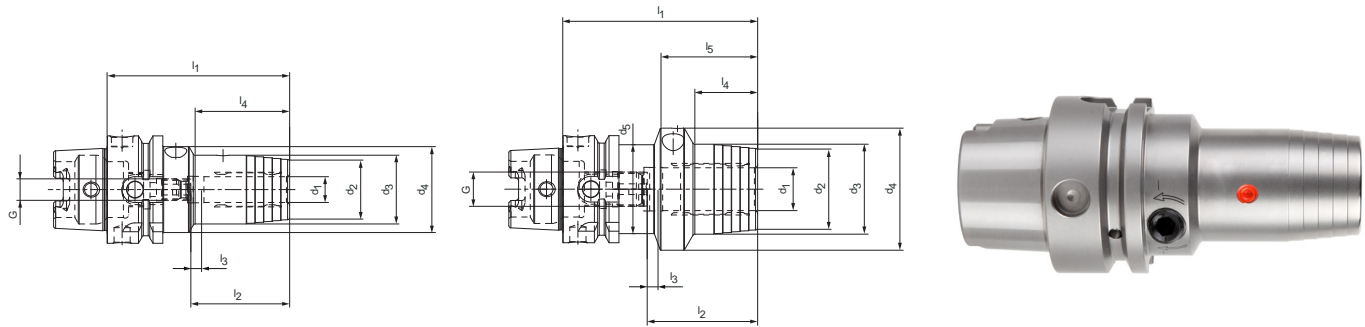

Lagerhaltige Vorzugsbaureihe Preferred series in stock
 Mit axialer Werkzeuglängeneinstellung With axial tool length adjustment

HSK-A	Baumaße Dimensions										G	Bestell-Bezeichnung Order designation	Bestell-Nr. Order no.
	d ₁	d ₂	d ₃	d ₄	d ₅	l ₁	l ₂	l ₃	l ₄	l ₅			
32	6,0	22,0	26,0	40,0	-	80,0	37,0	10,0	29,0	-	M5	HC06-80-HSK-A32	5222670
32	8,0	24,0	28,0	40,0	-	80,0	37,0	10,0	29,0	-	M6	HC08-80-HSK-A32	5222671
32	10,0	26,0	30,0	40,0	-	85,0	41,0	10,0	35,0	-	M6	HC10-85-HSK-A32	5222672
32	12,0	28,0	32,0	40,0	-	90,0	46,0	10,0	40,0	-	M6	HC12-90-HSK-A32	5222673
40	6,0	22,0	26,0	33,5	-	70,0	37,0	10,0	36,0	-	M5	HC06-70-HSK-A40	5222681
40	8,0	24,0	28,0	33,5	-	70,0	37,0	10,0	36,0	-	M6	HC08-70-HSK-A40	5222682
40	10,0	26,0	30,0	33,5	-	75,0	41,0	10,0	42,0	-	M6	HC10-75-HSK-A40	5222683
40	12,0	28,0	32,0	33,5	-	80,0	46,0	10,0	48,0	-	M6	HC12-80-HSK-A40	5222684
50	6,0	22,0	26,0	40,0	-	70,0	37,0	10,0	28,0	-	M5	HC06-70-HSK-A50	5221383
50	8,0	24,0	28,0	40,0	-	70,0	37,0	10,0	28,0	-	M6	HC08-70-HSK-A50	5222685
50	10,0	26,0	30,0	40,0	-	75,0	41,0	10,0	34,0	-	M8x1	HC10-75-HSK-A50	5221384
50	12,0	28,0	32,0	40,0	-	85,0	46,0	10,0	44,0	-	M10x1	HC12-85-HSK-A50	5222686
50	14,0	30,0	34,0	40,0	-	85,0	46,0	10,0	44,0	-	M10x1	HC14-85-HSK-A50	5221386
50	16,0	34,0	38,0	53,0	41,5	90,0	49,0	10,0	30,0	45,5	M12x1	HC16-90-HSK-A50	5222688
50	18,0	36,0	40,0	53,0	41,5	90,0	49,0	10,0	30,0	45,5	M12x1	HC18-90-HSK-A50	5222689
50	20,0	38,0	42,0	57,0	41,5	90,0	51,0	10,0	29,0	45,5	M16x1	HC20-90-HSK-A50	5222691
63	6,0	22,0	26,0	50,0	-	70,0	37,0	10,0	24,0	-	M5	HC06-70-HSK-A63	5222908
63	6,0	22,0	26,0	50,0	-	120,0	37,0	10,0	73,0	-	M5	HC06-120-HSK-A63	5222956
63	6,0	22,0	26,0	50,0	-	150,0	37,0	10,0	103,0	-	M5	HC06-150-HSK-A63	5222957
63	6,0	22,0	26,0	50,0	-	200,0	37,0	10,0	153,0	-	M5	HC06-200-HSK-A63	5222958
63	8,0	24,0	28,0	50,0	-	70,0	37,0	10,0	25,0	-	M6	HC08-70-HSK-A63	5222959
63	8,0	24,0	28,0	50,0	-	120,0	37,0	10,0	74,0	-	M6	HC08-120-HSK-A63	5222960
63	8,0	24,0	28,0	50,0	-	150,0	37,0	10,0	104,0	-	M6	HC08-150-HSK-A63	5222961
63	8,0	24,0	28,0	50,0	-	200,0	37,0	10,0	154,0	-	M6	HC08-200-HSK-A63	5222964
63	10,0	26,0	30,0	50,0	-	80,0	41,0	10,0	35,0	-	M8x1	HC10-80-HSK-A63	5222965
63	10,0	26,0	30,0	50,0	-	120,0	41,0	10,0	74,0	-	M8x1	HC10-120-HSK-A63	5222966
63	10,0	26,0	30,0	50,0	-	150,0	41,0	10,0	104,0	-	M8x1	HC10-150-HSK-A63	5222967
63	10,0	26,0	30,0	50,0	-	200,0	41,0	10,0	154,0	-	M8x1	HC10-200-HSK-A63	5222968
63	12,0	28,0	32,0	50,0	-	85,0	46,0	10,0	40,0	-	M10x1	HC12-85-HSK-A63	5222969
63	12,0	28,0	32,0	50,0	-	120,0	46,0	10,0	75,0	-	M10x1	HC12-120-HSK-A63	5222970
63	12,0	28,0	32,0	50,0	-	150,0	46,0	10,0	105,0	-	M10x1	HC12-150-HSK-A63	5222971
63	12,0	28,0	32,0	50,0	-	200,0	46,0	10,0	155,0	-	M10x1	HC12-200-HSK-A63	5222973
63	14,0	30,0	34,0	50,0	-	85,0	46,0	10,0	40,0	-	M10x1	HC14-85-HSK-A63	5222974
63	14,0	30,0	34,0	50,0	-	120,0	46,0	10,0	75,0	-	M10x1	HC14-120-HSK-A63	5222975
63	14,0	30,0	34,0	50,0	-	150,0	46,0	10,0	105,0	-	M10x1	HC14-150-HSK-A63	5222989
63	14,0	30,0	34,0	50,0	-	200,0	46,0	10,0	155,0	-	M10x1	HC14-200-HSK-A63	5222990
63	16,0	34,0	38,0	50,0	-	90,0	49,0	10,0	46,0	-	M12x1	HC16-90-HSK-A63	5222992
63	16,0	34,0	38,0	50,0	-	120,0	49,0	10,0	76,0	-	M12x1	HC16-120-HSK-A63	5222993
63	16,0	34,0	38,0	50,0	-	150,0	49,0	10,0	106,0	-	M12x1	HC16-150-HSK-A63	5222994

HC... HSK-A, DIN 69893-1

Schaft HSK-A nach DIN 69893-1 HSK-A shank according to DIN 69893-1

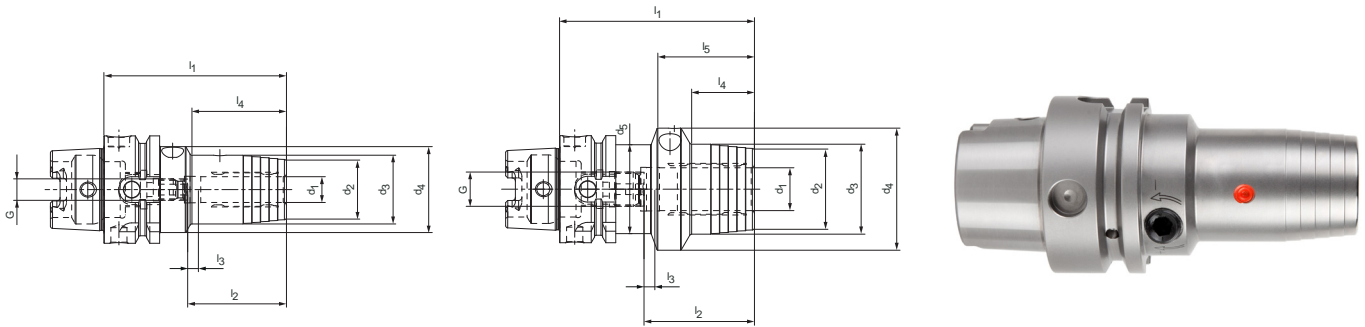

Lagerhaltige Vorzugsbaureihe Preferred series in stock

Mit axialer Werkzeuglängeneinstellung With axial tool length adjustment

HSK-A	Baumaße Dimensions										G	Bestell-Bezeichnung Order designation	Bestell-Nr. Order no.
	d ₁	d ₂	d ₃	d ₄	d ₅	l ₁	l ₂	l ₃	l ₄	l ₅			
63	16,0	34,0	38,0	50,0	-	200,0	49,0	10,0	156,0	-	M12x1	HC16-200-HSK-A63	5222995
63	18,0	36,0	40,0	50,0	-	90,0	49,0	10,0	47,0	-	M12x1	HC18-90-HSK-A63	5222996
63	18,0	36,0	40,0	50,0	-	120,0	49,0	10,0	77,0	-	M12x1	HC18-120-HSK-A63	5222997
63	18,0	36,0	40,0	50,0	-	150,0	49,0	10,0	107,0	-	M12x1	HC18-150-HSK-A63	5222998
63	18,0	36,0	40,0	50,0	-	200,0	49,0	10,0	157,0	-	M12x1	HC18-200-HSK-A63	5222999
63	20,0	38,0	42,0	50,0	-	90,0	51,0	10,0	48,0	-	M16x1	HC20-90-HSK-A63	5223000
63	20,0	38,0	42,0	50,0	-	120,0	51,0	10,0	78,0	-	M16x1	HC20-120-HSK-A63	5223001
63	20,0	38,0	42,0	50,0	-	150,0	51,0	10,0	108,0	-	M16x1	HC20-150-HSK-A63	5223002
63	20,0	38,0	42,0	50,0	-	200,0	51,0	10,0	158,0	-	M16x1	HC20-200-HSK-A63	5223003
63	25,0	53,0	57,0	52,5	-	120,0	57,0	10,0	63,0	-	M16x1	HC25-120-HSK-A63	5223004
63	25,0	53,0	57,0	52,5	-	150,0	57,0	10,0	63,0	-	M16x1	HC25-150-HSK-A63	5223005
63	25,0	53,0	57,0	52,5	-	200,0	57,0	10,0	63,0	-	M16x1	HC25-200-HSK-A63	5223006
63	32,0	59,0	63,0	59,0	52,5	125,0	61,0	10,0	61,0	77,0	M16x1	HC32-120-HSK-A63	5223007
63	32,0	59,0	63,0	59,0	52,5	150,0	61,0	10,0	65,0	77,0	M16x1	HC32-150-HSK-A63	5223008
63	32,0	59,0	63,0	59,0	52,2	200,0	61,0	10,0	65,0	77,0	M16x1	HC32-200-HSK-A63	5223009
80	6,0	22,0	26,0	50,0	-	70,0	37,0	10,0	24,0	-	M5	HC06-70-HSK-A80	5223014
80	8,0	24,0	28,0	50,0	-	70,0	37,0	10,0	24,0	-	M6	HC08-70-HSK-A80	5223015
80	10,0	26,0	30,0	50,0	-	80,0	41,0	10,0	35,0	-	M8x1	HC10-80-HSK-A80	5223016
80	12,0	28,0	32,0	50,0	-	85,0	46,0	10,0	40,0	-	M10x1	HC12-85-HSK-A80	5223017
80	14,0	30,0	34,0	50,0	-	85,0	46,0	10,0	40,0	-	M10x1	HC14-85-HSK-A80	5223018
80	16,0	34,0	38,0	50,0	-	95,0	49,0	10,0	51,0	-	M12x1	HC16-95-HSK-A80	5223019
80	18,0	36,0	40,0	50,0	-	95,0	49,0	10,0	51,0	-	M12x1	HC18-95-HSK-A80	5223020
80	20,0	38,0	42,0	50,0	-	95,0	51,0	10,0	51,0	-	M16x1	HC20-95-HSK-A80	5223021
80	25,0	53,0	57,0	63,0	-	110,0	57,0	10,0	65,0	-	M16x1	HC25-110-HSK-A80	5223022
80	32,0	59,0	63,0	66,5	-	125,0	61,0	10,0	63,0	-	M16x1	HC32-125-HSK-A80	5223024
100	6,0	22,0	26,0	50,0	-	75,0	37,0	10,0	26,0	-	M5	HC06-75-HSK-A100	5223150
100	6,0	22,0	26,0	50,0	-	120,0	37,0	10,0	71,0	-	M5	HC06-120-HSK-A100	5223151
100	8,0	24,0	28,0	50,0	-	75,0	37,0	10,0	26,0	-	M6	HC08-75-HSK-A100	5223152
100	8,0	24,0	28,0	50,0	-	120,0	37,0	10,0	71,0	-	M6	HC08-120-HSK-A100	5223153
100	10,0	26,0	30,0	50,0	-	90,0	41,0	10,0	42,0	-	M8x1	HC10-90-HSK-A100	5223154
100	10,0	26,0	30,0	50,0	-	120,0	41,0	10,0	72,0	-	M8x1	HC10-120-HSK-A100	5223155
100	12,0	28,0	32,0	50,0	-	95,0	46,0	10,0	47,0	-	M10x1	HC12-95-HSK-A100	5223156
100	12,0	28,0	32,0	50,0	-	120,0	46,0	10,0	72,0	-	M10x1	HC12-120-HSK-A100	5223159
100	14,0	30,0	34,0	50,0	-	95,0	46,0	10,0	47,0	-	M10x1	HC14-95-HSK-A100	5223160
100	16,0	34,0	38,0	50,0	-	100,0	49,0	10,0	53,0	-	M12x1	HC16-100-HSK-A100	5223161
100	18,0	36,0	40,0	50,0	-	100,0	49,0	10,0	53,0	-	M12x1	HC18-100-HSK-A100	5223162
100	20,0	38,0	42,0	50,0	-	105,0	51,0	10,0	59,0	-	M16x1	HC20-105-HSK-A100	5223163
100	25,0	53,0	57,0	63,0	-	110,0	57,0	10,0	62,0	-	M16x1	HC25-110-HSK-A100	5223164
100	32,0	59,0	63,0	67,0	-	110,0	61,0	10,0	62,0	-	M16x1	HC32-110-HSK-A100	5223165

HCP... HSK-A, DIN 69893-1



Kurze schwere Ausführung Short heavy-duty design
 Schaft HSK-A nach DIN 69893-1 HSK-A shank according to DIN 69893-1

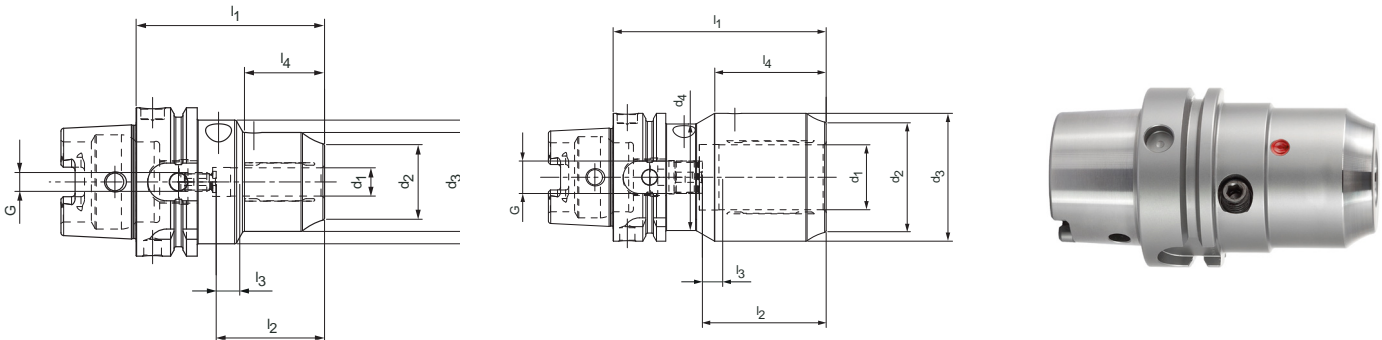

Lagerhaltige Vorzugsbaureihe Preferred series in stock
 Mit axialer Werkzeuglängeneinstellung With axial tool length adjustment

HSK-A	Baumaße Dimensions								G	Bestell-Bezeichnung Order designation	Bestell-Nr. Order no.
	d ₁	d ₂	d ₃	d ₄	l ₁	l ₂	l ₃	l ₄			
63	12,0	32,0	42,0	52,5	80,0	46,0	10,0	34,0	M8x1	HCP12-80-HSK-A63	5222902
63	20,0	38,0	49,0	52,5	80,0	51,0	10,0	36,0	M8x1	HCP20-80-HSK-A63	5222903
63*	32,0	54,0	63,0	52,5	105,0	61,0	10,0	55,0	M16x1	HCP32-105-HSK-A63	5222904
100	12,0	32,0	42,0	52,5	85,0	46,0	10,0	34,0	M8x1	HCP12-85-HSK-A100	5223144
100	20,0	38,0	49,0	52,5	85,0	51,0	10,0	36,0	M8x1	HCP20-85-HSK-A100	5223145
100	32,0	57,0	68,0	72,0	100,0	61,0	10,0	42,0	M8x1	HCP32-100-HSK-A100	5223146

* Hammerkopfvvariante siehe Zeichnung oben rechts

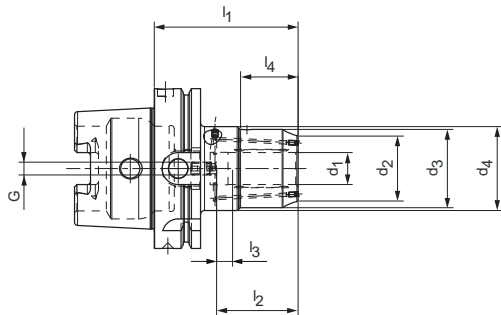

Kurze schwere Ausführung mit zwei Kühlkanalbohrungen, wiederverschließbar
 Short, heavy-duty design with two cooling channel holes, resealable
 Lagerhaltige Vorzugsbaureihe Preferred series in stock

HSK-A	Baumaße Dimensions								G	Bestell-Bezeichnung Order designation	Bestell-Nr. Order no.
	d ₁	d ₂	d ₃	d ₄	l ₁	l ₂	l ₃	l ₄			
63	12,0	32,0	42,0	52,5	80,0	46,0	10,0	34,0	M8x1	HCP12-80-C1-HSK-A63	5222905
63	16,0	38,0	46,0	52,5	80,0	49,0	10,0	35,0	M8x1	HCP16-80-C1-HSK-A63	5222906
63	20,0	41,0	49,0	52,5	80,0	51,0	10,0	36,0	M8x1	HCP20-80-C1-HSK-A63	5222907
100	12,0	32,0	42,0	52,5	90,0	46,0	10,0	34,0	M8x1	HCP12-90-C1-HSK-A100	5223147
100	20,0	41,0	49,0	52,5	90,0	51,0	10,0	36,0	M8x1	HCP20-90-C1-HSK-A100	5223148
100	32,0	57,0	68,0	72,0	105,0	61,0	10,0	42,0	M8x1	HCP32-105-C1-HSK-A100	5223149

HCS... HSK-A, DIN 69893-1



Schlankes Hydrodehnspannfutter Slim hydraulic chuck
 Schaft HSK-A nach DIN 69893-1 HSK-A shank according to DIN 69893-1

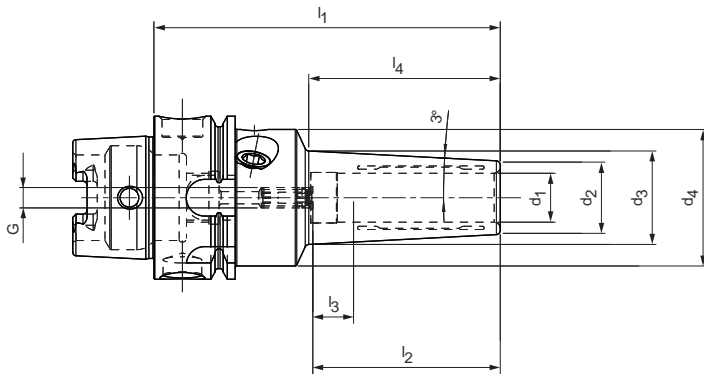

Lagerhaltige Vorzugsbaureihe Preferred series in stock
 Schlanke Ausführung 3° Slim design 3°

HSK-A	Baumaße Dimensions								G	Bestell-Bezeichnung Order designation	Bestell-Nr. Order no.
	d ₁	d ₂	d ₃	d ₄	l ₁	l ₂	l ₃	l ₄			
40	3,0	9,0	13,8	33,5	85,0	28,0	16,0	45,0	M2,5	HCS03-85-HSK-A40	5222674
40	4,0	10,0	14,8	33,5	85,0	28,0	12,0	45,0	M2,5	HCS04-85-HSK-A40	5222675
40	5,0	11,0	15,8	33,5	85,0	28,0	8,0	45,0	M2,5	HCS05-85-HSK-A40	5222676
40	6,0	12,0	16,9	33,5	85,0	37,0	10,0	46,0	M5	HCS06-85-HSK-A40	5222677
40	8,0	14,0	18,9	33,5	85,0	37,0	10,0	46,0	M6	HCS08-85-HSK-A40	5222678
40	10,0	16,0	21,0	33,5	85,0	41,0	10,0	47,0	M5	HCS10-85-HSK-A40	5222679
40	12,0	18,0	23,0	33,5	85,0	46,0	10,0	47,0	M5	HCS12-85-HSK-A40	5222680
63	3,0	9,0	16,7	50,0	120,0	28,0	16,0	73,0	M2,5	HCS03-120-HSK-A63	5222692
63	4,0	10,0	17,7	50,0	120,0	28,0	12,0	73,0	M2,5	HCS04-120-HSK-A63	5222694
63	5,0	11,0	18,7	50,0	120,0	28,0	8,0	73,0	M2,5	HCS05-120-HSK-A63	5222695
63	6,0	12,0	19,8	50,0	120,0	37,0	10,0	74,0	M5	HCS06-120-HSK-A63	5222697
63	8,0	14,0	21,8	50,0	120,0	37,0	10,0	74,0	M6	HCS08-120-HSK-A63	5222698
63	10,0	16,0	23,8	50,0	120,0	41,0	10,0	74,0	M8x1	HCS10-120-HSK-A63	5222699
63	12,0	18,0	25,9	50,0	120,0	46,0	10,0	75,0	M10x1	HCS12-120-HSK-A63	5222700
63	14,0	22,0	29,5	50,0	120,0	46,0	10,0	71,0	M10x1	HCS14-120-HSK-A63	5222702
63	16,0	24,0	31,5	50,0	120,0	49,0	10,0	71,5	M12x1	HCS16-120-HSK-A63	5222703
63	18,0	26,0	33,6	50,0	120,0	49,0	10,0	72,0	M12x1	HCS18-120-HSK-A63	5222706
63	20,0	28,0	35,6	50,0	120,0	51,0	10,0	72,0	M16x1	HCS20-120-HSK-A63	5222708
63	3,0	9,0	12,5	50,0	80,0	28,0	16,0	33,0	M2,5	HCS03-80-HSK-A63	5222709
63	4,0	10,0	13,5	50,0	80,0	28,0	12,0	33,0	M2,5	HCS04-80-HSK-A63	5222711
63	5,0	11,0	14,5	50,0	80,0	28,0	8,0	33,0	M2,5	HCS05-80-HSK-A63	5222712
63	6,0	12,0	15,6	50,0	80,0	37,0	10,0	34,0	M5	HCS06-80-HSK-A63	5222714
63	8,0	14,0	17,6	50,0	80,0	37,0	10,0	34,0	M6	HCS08-80-HSK-A63	5222715
63	10,0	16,0	20,0	50,0	85,0	41,0	10,0	39,0	M8x1	HCS10-85-HSK-A63	5222716
63	12,0	18,0	22,7	50,0	90,0	46,0	10,0	45,0	M10x1	HCS12-90-HSK-A63	5222717
63	14,0	22,0	26,7	50,0	90,0	46,0	10,0	45,0	M10x1	HCS14-90-HSK-A63	5222718
63	16,0	24,0	28,9	50,0	95,0	49,0	10,0	47,0	M12x1	HCS16-95-HSK-A63	5222719
63	18,0	26,0	30,9	50,0	95,0	49,0	10,0	47,0	M12x1	HCS18-95-HSK-A63	5222720
63	20,0	28,0	33,4	50,0	100,0	51,0	10,0	52,0	M16x1	HCS20-100-HSK-A63	5222721

HCS... HSK-A, DIN 69893-1



Schlankes Hydrodehnspannfutter Slim hydraulic chuck
 Schaft HSK-A nach DIN 69893-1 HSK-A shank according to DIN 69893-1

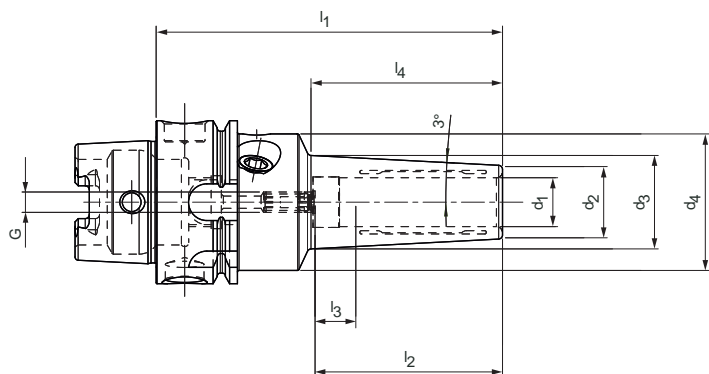

Schlanke Ausführung 3° Slim design 3°

HSK-A	Baumaße Dimensions								G	Bestell-Bezeichnung Order designation	Bestell-Nr. Order no.
	d ₁	d ₂	d ₃	d ₄	l ₁	l ₂	l ₃	l ₄			
100	3,0	9,0	16,4	50,0	120,0	28,0	16,0	70,0	M2,5	HCS03-120-HSK-A100	5223025
100	4,0	10,0	17,4	50,0	120,0	28,0	12,0	70,0	M2,5	HCS04-120-HSK-A100	5223026
100	5,0	11,0	18,4	50,0	120,0	28,0	8,0	70,0	M2,5	HCS05-120-HSK-A100	5223027
100	6,0	12,0	19,4	50,0	120,0	37,0	10,0	70,0	M5	HCS06-120-HSK-A100	5223028
100	8,0	14,0	21,5	50,0	120,0	37,0	10,0	71,0	M6	HCS08-120-HSK-A100	5223029
100	10,0	16,0	23,5	50,0	120,0	41,0	10,0	71,0	M8x1	HCS10-120-HSK-A100	5223030
100	12,0	18,0	25,6	50,0	120,0	46,0	10,0	72,0	M10x1	HCS12-120-HSK-A100	5223031
100	14,0	22,0	29,2	50,0	120,0	46,0	10,0	68,0	M10x1	HCS14-120-HSK-A100	5223032
100	16,0	24,0	31,2	50,0	120,0	49,0	10,0	68,0	M12x1	HCS16-120-HSK-A100	5223033
100	18,0	26,0	33,3	50,0	120,0	49,0	10,0	69,0	M12x1	HCS18-120-HSK-A100	5223034
100	20,0	28,0	35,3	50,0	120,0	51,0	10,0	69,0	M16x1	HCS20-120-HSK-A100	5223035

Maßangaben in mm.
 Zubehör und Ersatzteile siehe Seite 25
 Weitere Abmessungen und Sonderausführungen auf Anfrage.

Dimensions in mm.
 For accessories and spare parts, see page 25
 Other dimensions and special designs on request.

HCS... HSK-A, DIN 69893-1



Schlankes Hydrodehnspannfutter Slim hydraulic chuck
 Schaft HSK-A nach DIN 69893-1 HSK-A shank according to DIN 69893-1

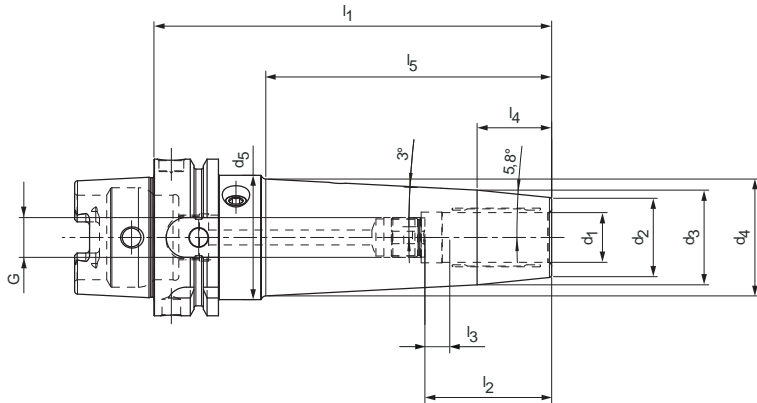

Schlanke Ausführung 3° Slim design 3°
 optimierte Kontur für maximale Biegesteifigkeit Optimised contour for maximum bending stiffness
 Lagerhaltige Vorzugsbaureihe Preferred series in stock

HSK-A	Baumaße Dimensions										G	Bestell-Bezeichnung Order designation	Bestell-Nr. Order no.
	d ₁	d ₂	d ₃	d ₄	d ₅	l ₁	l ₂	l ₃	l ₄	l ₅			
63	3,0	13,0	27,3	31,5	50,0	160,0	28,0	16,0	70,0	110,0	M2,5	HCS03-160-HSK-A63	5222722
63	3,0	13,0	27,3	35,8	50,0	200,0	28,0	16,0	70,0	151,0	M2,5	HCS03-200-HSK-A63	5222723
63	4,0	14,0	28,3	32,5	50,0	160,0	28,0	12,0	70,0	110,0	M2,5	HCS04-160-HSK-A63	5222724
63	4,0	14,0	28,3	36,8	50,0	200,0	28,0	12,0	70,0	151,0	M2,5	HCS04-200-HSK-A63	5222728
63	5,0	15,0	29,3	33,5	50,0	160,0	28,0	8,0	70,0	110,0	M2,5	HCS05-160-HSK-A63	5222729
63	5,0	15,0	29,3	37,8	50,0	200,0	28,0	8,0	70,0	151,0	M2,5	HCS05-200-HSK-A63	5222730
63	6,0	16,0	28,2	33,6	50,0	160,0	37,0	10,0	60,0	111,0	M5	HCS06-160-HSK-A63	5222731
63	6,0	16,0	28,2	37,9	50,0	200,0	37,0	10,0	60,0	152,0	M5	HCS06-200-HSK-A63	5222732
63	8,0	18,0	28,2	34,6	50,0	160,0	37,0	10,0	50,0	111,0	M6	HCS08-160-HSK-A63	5222733
63	8,0	18,0	28,2	38,9	50,0	200,0	37,0	10,0	50,0	152,0	M6	HCS08-200-HSK-A63	5222734
63	10,0	20,0	29,2	36,3	50,0	160,0	41,0	10,0	45,0	113,0	M8x1	HCS10-160-HSK-A63	5222735
63	10,0	20,0	29,2	40,6	50,0	200,0	41,0	10,0	45,0	154,0	M8x1	HCS10-200-HSK-A63	5222737
63	12,0	22,0	30,2	37,8	50,0	160,0	46,0	10,0	40,0	113,0	M10x1	HCS12-160-HSK-A63	5222738
63	12,0	22,0	30,2	42,1	50,0	200,0	46,0	10,0	40,0	154,0	M10x1	HCS12-200-HSK-A63	5222739
63	14,0	26,0	34,2	41,8	50,0	160,0	46,0	10,0	40,0	113,0	M10x1	HCS14-160-HSK-A63	5222740
63	14,0	26,0	34,2	46,1	50,0	200,0	46,0	10,0	40,0	154,0	M10x1	HCS14-200-HSK-A63	5222741
63	16,0	28,0	36,2	43,8	50,0	160,0	49,0	10,0	40,0	113,0	M12x1	HCS16-160-HSK-A63	5222742
63	16,0	28,0	36,2	48,1	50,0	200,0	49,0	10,0	40,0	154,0	M12x1	HCS16-200-HSK-A63	5222895
63	18,0	30,0	36,1	45,1	50,0	160,0	49,0	10,0	30,0	115,0	M12x1	HCS18-160-HSK-A63	5222896
63	18,0	30,0	36,1	49,4	50,0	200,0	49,0	10,0	30,0	156,0	M12x1	HCS18-200-HSK-A63	5222897
63	20,0	32,0	38,1	47,1	50,0	160,0	51,0	10,0	30,0	115,0	M16x1	HCS20-160-HSK-A63	5222899
63	20,0	32,0	38,1	49,1	50,0	200,0	51,0	10,0	30,0	156,0	M16x1	HCS20-200-HSK-A63	5222900

HC... HSK-E, DIN 69893-5



Mit axialer Werkzeuglängeneinstellung With axial tool length adjustment
 Schaft HSK-E nach DIN 69893-5 HSK-E shank according to DIN 69893-5

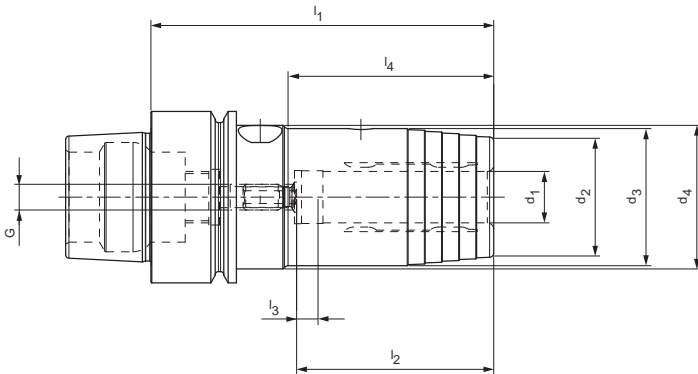

Lagerhaltige Vorzugsbaureihe Preferred series in stock

HSK-E	Baumaße Dimensions								G	Bestell-Bezeichnung Order designation	Bestell-Nr. Order no.
	d ₁	d ₂	d ₃	d ₄	l ₁	l ₂	l ₃	l ₄			
40	6,0	22,0	26,0	33,5	70,0	37,0	10,0	36,0	M5	HC06-70-HSK-E40	5223168
40	8,0	24,0	28,0	33,5	70,0	37,0	10,0	36,0	M6	HC08-70-HSK-E40	5223170
40	10,0	26,0	30,0	33,5	75,0	41,0	10,0	42,0	M6	HC10-75-HSK-E40	5223171
40	12,0	28,0	32,0	33,5	80,0	46,0	10,0	48,0	M6	HC12-80-HSK-E40	5223172
50	6,0	22,0	26,0	40,0	70,0	37,0	10,0	28,0	M5	HC06-70-HSK-E50	5223173
50	8,0	24,0	28,0	40,0	70,0	37,0	10,0	28,0	M6	HC08-70-HSK-E50	5223174
50	10,0	26,0	30,0	40,0	75,0	41,0	10,0	34,0	M8x1	HC10-75-HSK-E50	5223175
50	12,0	28,0	32,0	40,0	85,0	46,0	10,0	44,0	M10x1	HC12-85-HSK-E50	5223176
50	14,0	30,0	34,0	40,0	85,0	46,0	10,0	44,0	M10x1	HC14-85-HSK-E50	5223177
50	16,0	34,0	38,0	42,0	90,0	49,0	10,0	30,0	M12x1	HC16-90-HSK-E50	5223178
50	18,0	36,0	40,0	42,0	90,0	49,0	10,0	29,0	M12x1	HC18-90-HSK-E50	5223179
50	20,0	38,0	42,0	42,0	90,0	51,0	10,0	29,0	M16x1	HC20-90-HSK-E50	5223180

HCS... HSK-E, DIN 69893-5



Schlankes Hydrodehnspannfutter Slim hydraulic chuck
 Mit axialer Werkzeuflängeneinstellung With axial tool length adjustment
 Schaft HSK-E nach DIN 69893-5 HSK-E shank according to DIN 69893-5

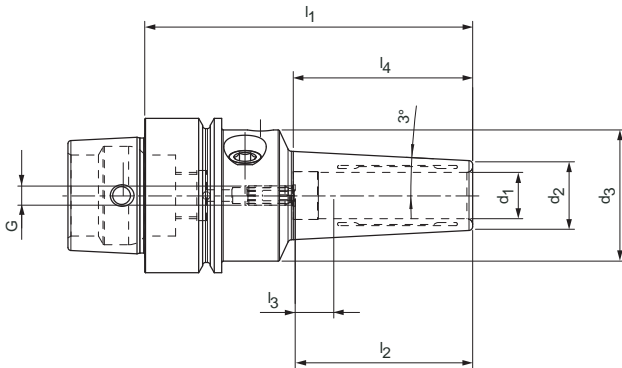

Schlankes Ausführung, 3° auf Anfrage erhältlich Slim design 3° available on request

HSK-E	Baumaße Dimensions							G	Bestell-Bezeichnung Order designation	Bestell-Nr. Order no.
	d ₁	d ₂	d ₃	l ₁	l ²	l ₃	l ₄			
40	3,0	9,0	34,0	85,0	28,0	16,0	45,0	M2,5	HCS03-85-HSK-E40	5222940
40	4,0	10,0	34,0	85,0	28,0	12,0	45,0	M2,5	HCS04-85-HSK-E40	5222941
40	5,0	11,0	34,0	85,0	28,0	8,0	45,0	M2,5	HCS05-85-HSK-E40	5222943
40	6,0	12,0	34,0	85,0	37,0	10,0	46,0	M5	HCS06-85-HSK-E40	5222944
40	8,0	14,0	34,0	85,0	37,0	10,0	46,0	M6	HCS08-85-HSK-E40	5222945
40	10,0	16,0	34,0	85,0	41,0	10,0	47,0	M5	HCS10-85-HSK-E40	5222946
40	12,0	18,0	34,0	85,0	46,0	10,0	47,0	M5	HCS12-85-HSK-E40	5222947
50	3,0	9,0	42,0	85,0	28,0	16,0	37,0	M2,5	HCS03-85-HSK-E50	5222948
50	4,0	10,0	42,0	85,0	28,0	12,0	37,0	M2,5	HCS04-85-HSK-E50	5222949
50	5,0	11,0	42,0	85,0	28,0	8,0	37,0	M2,5	HCS05-85-HSK-E50	5222950
50	6,0	12,0	42,0	85,0	37,0	10,0	38,0	M5	HCS06-85-HSK-E50	5222951
50	8,0	14,0	42,0	85,0	37,0	10,0	38,0	M6	HCS08-85-HSK-E50	5222952
50	10,0	16,0	42,0	85,0	41,0	10,0	39,0	M8x1	HCS10-85-HSK-E50	5222953
50	12,0	18,0	42,0	85,0	46,0	10,0	39,0	M8x1	HCS12-85-HSK-E50	5222954

Maßangaben in mm.
 Zubehör und Ersatzteile siehe Seite 25
 Weitere Abmessungen und Sonderausführungen auf Anfrage.

Dimensions in mm.
 For accessories and spare parts, see page 25
 Other dimensions and special designs on request.

HC... SK, ISO 7388-1



Mit axialer Werkzeuglängeneinstellung With axial tool length adjustment
 Schaft SK nach ISO 7388-1 Form AD/AF Shank SK to ISO 7388-1 form AD/AF

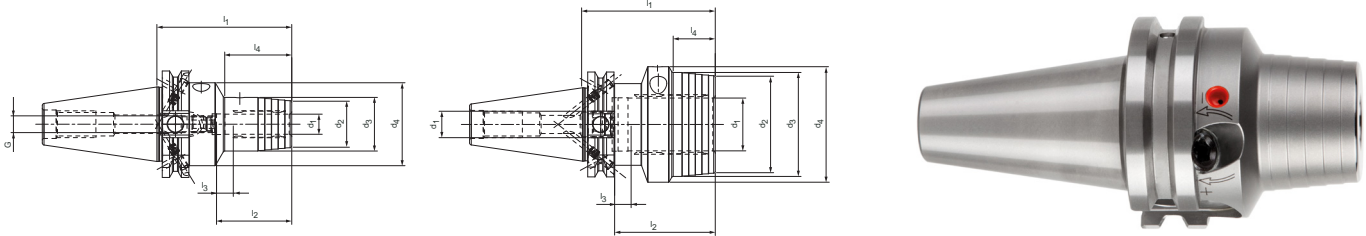

Lagerhaltige Vorzugsbaureihe Preferred series in stock

SK	Baumaße Dimensions										G	Bestell-Bezeichnung Order designation	Bestell-Nr. Order no.
	d ₁	d ₂	d ₃	d ₄	d ₅	l ₁	l ₂	l ₃	l ₄	l ₅			
30*	6,0	23,0	26,0	44,5	-	55,0	37,0	10,0	20,0	-	M5	HC06-55-SK30	5223036
30*	8,0	24,0	28,0	44,5	-	55,0	37,0	10,0	20,0	-	M6	HC08-55-SK30	5223037
30*	10,0	27,0	30,0	44,5	-	55,0	41,0	10,0	21,0	-	M8x1	HC10-55-SK30	5223038
30*	12,0	28,0	32,0	44,5	-	55,0	46,0	10,0	22,0	-	M8x1	HC12-55-SK30	5223039
30*	14,0	30,0	34,0	44,5	-	90,0	46,0	10,0	42,0	-	M8x1	HC14-90-SK30	5223044
30*	16,0	34,0	38,0	44,5	-	90,0	49,0	10,0	50,0	-	M8x1	HC16-90-SK30	5223045
30*	18,0	36,0	40,0	44,5	-	90,0	49,0	10,0	50,0	-	M8x1	HC18-90-SK30	5223046
30*	20,0	38,0	42,0	44,5	-	90,0	51,0	10,0	50,0	-	M8x1	HC20-90-SK30	5223047
40	6,0	22,0	26,0	49,5	-	80,5	37,0	10,0	29,5	-	M5	HC06-80,5-SK40	5223048
40	8,0	24,0	28,0	49,5	-	80,5	37,0	10,0	30,0	-	M6	HC08-80,5-SK40	5223049
40	10,0	26,0	30,0	49,5	-	80,5	41,0	10,0	35,0	-	M8x1	HC10-80,5-SK40	5223050
40	12,0	28,0	32,0	49,5	-	80,5	46,0	10,0	40,0	-	M10x1	HC12-80,5-SK40	5223051
40	14,0	30,0	34,0	49,5	-	80,5	46,0	10,0	40,0	-	M10x1	HC14-80,5-SK40	5223052
40	16,0	34,0	38,0	49,5	-	80,5	49,0	10,0	45,0	-	M12x1	HC16-80,5-SK40	5223053
40	18,0	36,0	40,0	49,5	-	80,5	49,0	10,0	46,0	-	M12x1	HC18-80,5-SK40	5223054
40	20,0	38,0	42,0	49,5	-	80,5	51,0	10,0	47,0	-	M16x1	HC20-80,5-SK40	5223055
40	25,0	51,0	55,0	63,0	49,5	80,5	57,0	10,0	28,0	42,0	M16x1	HC25-80,5-SK40	5223056
40	32,0	59,0	63,0	70,0	49,5	80,5	61,0	10,0	20,0	41,0	M16x1	HC32-80,5-SK40	5223057
50	6,0	22,0	26,0	49,5	-	80,5	37,0	10,0	29,5	-	M5	HC06-80,5-SK50	5223059
50	8,0	24,0	28,0	49,5	-	80,5	37,0	10,0	30,0	-	M6	HC08-80,5-SK50	5223060
50	10,0	26,0	30,0	49,5	-	80,5	41,0	10,0	35,0	-	M8x1	HC10-80,5-SK50	5223062
50	12,0	28,0	32,0	49,5	-	80,5	46,0	10,0	40,0	-	M10x1	HC12-80,5-SK50	5223063
50	14,0	30,0	34,0	49,5	-	80,5	46,0	10,0	40,0	-	M10x1	HC14-80,5-SK50	5223064
50	16,0	34,0	38,0	49,5	-	80,5	49,0	10,0	45,0	-	M12x1	HC16-80,5-SK50	5223065
50	18,0	36,0	40,0	49,5	-	80,5	49,0	10,0	46,0	-	M12x1	HC18-80,5-SK50	5223066
50	20,0	38,0	42,0	49,5	-	80,5	51,0	10,0	42,0	-	M16x1	HC20-80,5-SK50	5223067
50	25,0	51,0	55,0	63,0	-	100,0	57,0	10,0	48,0	-	M16x1	HC25-100-SK50	5223068
50	32,0	59,0	63,0	70,0	-	100,0	61,0	10,0	61,0	-	M16x1	HC32-100-SK50	5223069

* Ausführung: Steilkegelgröße ist nicht in Kombi-Ausführung AD/AF erhältlich
 * Version: Steep taper size is not available in combination version AD/AF

HCP... SK, DIN 69893-1



Kurze schwere Ausführung Short heavy-duty design

Mit axialer Werkzeuglängeneinstellung With axial tool length adjustment

Schaft SK nach ISO 7388-1 Form AD/AF Shank SK to ISO 7388-1 form AD/AF

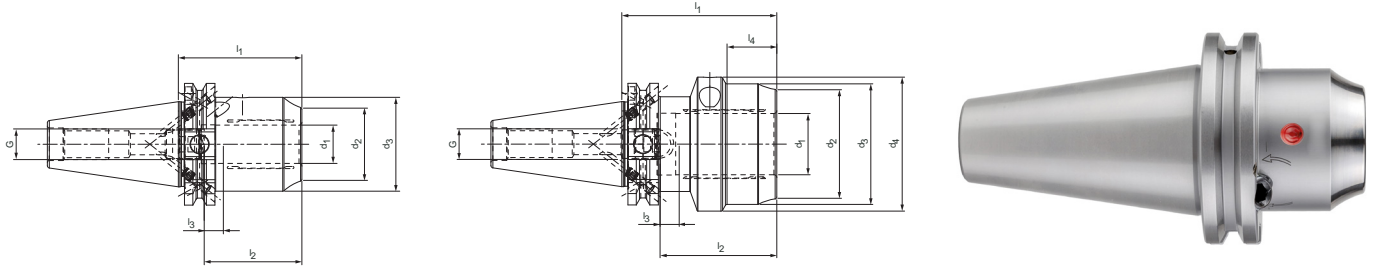

Lagerhaltige Vorzugsbaureihe Preferred series in stock

SK	Baumaße Dimensions								G	Bestell-Bezeichnung Order designation	Bestell-Nr. Order no.
	d ₁	d ₂	d ₃	d ₄	l ₁	l ₂	l ₃	l ₄			
40	12,0	32,0	42,0	-	50,0	46,0	10,0	-	M8x1	HCP12-50-SK40	5222909
40	20,0	38,0	49,0	-	64,5	51,0	10,0	-	M16x1	HCP20-64,5-SK40	5222913
40	32,0	57,0	63,0	70,0	81,0	61,0	10,0	26,0	M16x1	HCP32-81-SK40	5222914
50	12,0	32,0	42,0	-	50,0	46,0	10,0	-	M8x1	HCP12-50-SK50	5222915
50	20,0	38,0	49,0	-	64,5	51,0	10,0	-	M16x1	HCP20-64,5-SK50	5222916
50	32,0	57,0	68,0	72,0	81,0	61,0	10,0	35,0	M16x1	HCP32-81-SK50	5222917

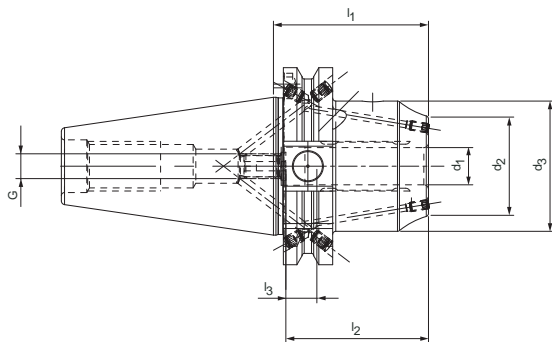

Kurze schwere Ausführung mit zwei Kühlkanalbohrungen, wiederverschließbar

Short, heavy-duty design with two cooling channel holes, resealable

Lagerhaltige Vorzugsbaureihe Preferred series in stock

SK	Baumaße Dimensions						G	Bestell-Bezeichnung Order designation	Bestell-Nr. Order no.
	d ₁	d ₂	d ₃	l ₁	l ₂	l ₃			
40	12,0	32,0	42,0	50,0	46,0	10,0	M8x1	HCP12-50-C1-SK40	5222918
40	16,0	38,0	46,0	64,5	49,0	10,0	M12x1	HCP16-64,5-C1-SK40	5222919
40	20,0	41,0	49,0	64,5	51,0	10,0	M16x1	HCP20-64,5-C1-SK40	5222920

HCS... SK, ISO 7388-1



Schlankes Hydrodehnspannfutter Slim hydraulic chuck

Mit axialer Werkzeuglängeneinstellung With axial tool length adjustment

Schaft SK nach ISO 7388-1 Form AD/AF Shank SK to ISO 7388-1 form AD/AF

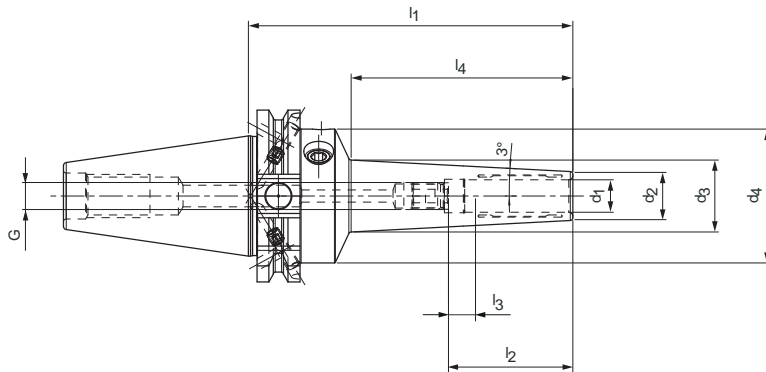

Schlanke Ausführung 3° Slim design 3°

Lagerhaltige Vorzugsbaureihe Preferred series in stock

SK	Baumaße Dimensions								G	Bestell-Bezeichnung Order designation	Bestell-Nr. Order no.
	d ₁	d ₂	d ₃	d ₄	l ₁	l ₂	l ₃	l ₄			
30*	3,0	9,0	13,2	40,0	80,0	28,0	16,0	40,0	M2,5	HCS03-80-SK30	5222743
30*	4,0	10,0	14,2	40,0	80,0	28,0	12,0	40,0	M2,5	HCS04-80-SK30	5222744
30*	5,0	11,0	15,3	40,0	80,0	28,0	8,0	41,0	M2,5	HCS05-80-SK30	5222745
30*	6,0	12,0	16,3	40,0	80,0	37,0	10,0	41,0	M5	HCS06-80-SK30	5222746
30*	8,0	14,0	18,3	40,0	80,0	37,0	10,0	41,0	M6	HCS08-80-SK30	5222747
30*	10,0	16,0	20,5	40,0	80,0	41,0	10,0	42,0	M8x1	HCS10-80-SK30	5222772
30*	12,0	18,0	22,5	40,0	80,0	46,0	10,0	42,0	M8x1	HCS12-80-SK30	5222773
40	3,0	9,0	17,4	49,5	120,0	28,0	16,0	80,0	M2,5	HCS03-120-SK40	5222774
40	4,0	10,0	18,4	49,5	120,0	28,0	12,0	80,0	M2,5	HCS04-120-SK40	5222775
40	5,0	11,0	19,4	49,5	120,0	28,0	8,0	80,0	M2,5	HCS05-120-SK40	5222777
40	6,0	12,0	20,4	49,5	120,0	37,0	10,0	80,0	M5	HCS06-120-SK40	5222778
40	8,0	14,0	22,4	49,5	120,0	37,0	10,0	80,0	M6	HCS08-120-SK40	5222780
40	10,0	16,0	24,5	49,5	120,0	41,0	10,0	81,0	M8x1	HCS10-120-SK40	5222781
40	12,0	18,0	26,6	49,5	120,0	46,0	10,0	82,0	M10x1	HCS12-120-SK40	5222782
40	14,0	22,0	30,3	49,5	120,0	46,0	10,0	79,0	M10x1	HCS14-120-SK40	5222783
40	16,0	24,0	32,3	49,5	120,0	49,0	10,0	79,0	M12x1	HCS16-120-SK40	5222784
40	18,0	26,0	34,4	49,5	120,0	49,0	10,0	80,0	M12x1	HCS18-120-SK40	5222785
40	20,0	28,0	36,4	49,5	120,0	51,0	10,0	80,0	M16x1	HCS20-120-SK40	5222786

* Ausführung: Steilkegelgröße ist nicht in Kombi-Ausführung AD/AF erhältlich

* Version: Steep taper size is not available in combination version AD/AF

Schlanke Ausführung 3° | Auf Anfrage erhältlich Slim version 3° | Available on request

40	3,0	9,0	13,2	49,5	80,0	28,0	16,0	40,0	M2,5	HCS03-80-SK40	5222787
40	4,0	10,0	14,2	49,5	80,0	28,0	12,0	40,0	M2,5	HCS04-80-SK40	5222788
40	5,0	11,0	15,2	49,5	80,0	28,0	8,0	40,0	M2,5	HCS05-80-SK40	5222789
40	6,0	12,0	16,2	49,5	80,0	37,0	10,0	40,0	M5	HCS06-80-SK40	5222790
40	8,0	14,0	18,2	49,5	80,0	37,0	10,0	40,0	M6	HCS08-80-SK40	5222791
40	10,0	16,0	20,3	49,5	80,0	41,0	10,0	41,0	M8x1	HCS10-80-SK40	5222792
40	12,0	18,0	22,4	49,5	80,0	46,0	10,0	42,0	M10x1	HCS12-80-SK40	5222793
40	14,0	22,0	26,4	49,5	80,0	46,0	10,0	42,0	M10x1	HCS14-80-SK40	5222794
40	16,0	24,0	28,2	49,5	80,0	49,0	10,0	40,0	M12x1	HCS16-80-SK40	5222795
40	18,0	26,0	30,2	49,5	80,0	49,0	10,0	40,0	M12x1	HCS18-80-SK40	5222796
40	20,0	28,0	32,7	49,5	85,0	51,0	10,0	45,0	M16x1	HCS20-85-SK40	5222797

HCS... SK, ISO 7388-1



Mit axialer Werkzeuglängeneinstellung With axial tool length adjustment
 Schaft SK nach ISO 7388-1 Form AD/AF Shank SK to ISO 7388-1 form AD/AF

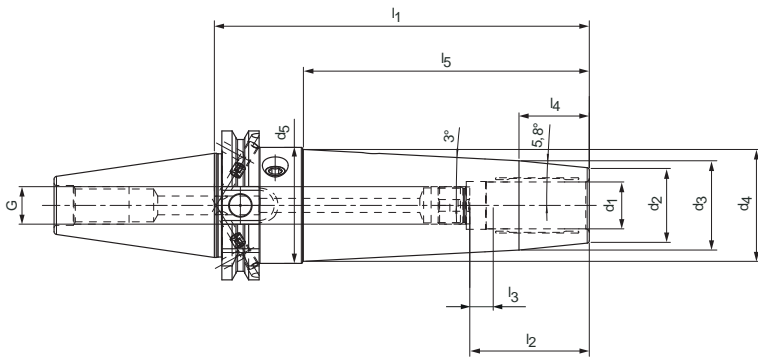

Schlanke Ausführung 3°, optimierte Kontur für maximale Biegesteifigkeit Slim design 3°, optimised contour for maximum bending stiffness
 Lagerhaltige Vorzugsbaureihe Preferred series in stock

SK	Baumaße Dimensions										G	Bestell-Bezeichnung Order designation	Bestell-Nr. Order no.
	d ₁	d ₂	d ₃	d ₄	d ₅	l ₁	l ₂	l ₃	l ₄	l ₅			
40	3,0	13,0	27,2	49,5	49,5	160,0	28,0	16,0	70,0	117,0	M2,5	HCS03-160-SK40	5222798
40	3,0	13,0	27,2	49,5	49,5	200,0	28,0	16,0	70,0	158,0	M2,5	HCS03-200-SK40	5222799
40	4,0	14,0	28,2	49,5	49,5	160,0	28,0	12,0	70,0	117,0	M2,5	HCS04-160-SK40	5222800
40	4,0	14,0	28,2	49,5	49,5	200,0	28,0	12,0	70,0	158,0	M2,5	HCS04-200-SK40	5222801
40	5,0	15,0	29,2	49,5	49,5	160,0	28,0	8,0	70,0	117,0	M2,5	HCS05-160-SK40	5222802
40	5,0	15,0	29,2	49,5	49,5	200,0	28,0	8,0	70,0	158,0	M2,5	HCS05-200-SK40	5222803
40	6,0	16,0	28,2	49,5	49,5	160,0	37,0	10,0	60,0	119,0	M5	HCS06-160-SK40	5222804
40	6,0	16,0	28,2	49,5	49,5	200,0	37,0	10,0	60,0	160,5	M5	HCS06-200-SK40	5222805
40	8,0	18,0	28,2	49,5	49,5	160,0	37,0	10,0	50,0	119,5	M6	HCS08-160-SK40	5222806
40	8,0	18,0	28,2	49,5	49,5	200,0	37,0	10,0	50,0	160,5	M6	HCS08-200-SK40	5222807
40	10,0	20,0	29,2	49,5	49,5	160,0	41,0	10,0	45,0	121,0	M8x1	HCS10-160-SK40	5222808
40	10,0	20,0	29,2	49,5	49,5	200,0	41,0	10,0	45,0	162,0	M8x1	HCS10-200-SK40	5222809
40	12,0	22,0	30,2	49,5	49,5	160,0	46,0	10,0	40,0	122,0	M10x1	HCS12-160-SK40	5222810
40	12,0	22,0	30,2	49,5	49,5	200,0	46,0	10,0	40,0	163,0	M10x1	HCS12-200-SK40	5222811
40	14,0	26,0	34,2	49,5	49,5	160,0	46,0	10,0	40,0	121,0	M10x1	HCS14-160-SK40	5222812
40	14,0	26,0	34,2	49,5	49,5	200,0	46,0	10,0	40,0	162,0	M10x1	HCS14-200-SK40	5222813
40	16,0	28,0	36,2	49,5	49,5	160,0	49,0	10,0	40,0	121,0	M12x1	HCS16-160-SK40	5222814
40	16,0	28,0	36,2	49,5	49,5	200,0	49,0	10,0	40,0	162,0	M12x1	HCS16-200-SK40	5222815
40	18,0	30,0	36,1	49,5	49,5	160,0	49,0	10,0	30,0	122,0	M12x1	HCS18-160-SK40	5222816
40	18,0	30,0	36,1	49,5	49,5	200,0	49,0	10,0	30,0	163,0	M12x1	HCS18-200-SK40	5222817
40	20,0	32,0	38,1	49,5	49,5	160,0	51,0	10,0	30,0	122,0	M16x1	HCS20-160-SK40	5222818
40	20,0	32,0	38,1	49,5	49,5	200,0	51,0	10,0	30,0	163,0	M16x1	HCS20-200-SK40	5222819

Maßangaben in mm.
 Zubehör und Ersatzteile siehe Seite 25
 Weitere Abmessungen und Sonderausführungen auf Anfrage.

Dimensions in mm.
 For accessories and spare parts, see page 25
 Other dimensions and special designs on request.

HC... SK, ISO 7388-1



Für Werkzeugschärf- und Schleifmaschinen, mit axialer Werkzeuglängeneinstellung
 For tool sharpening and grinding machines, with axial tool length adjustment
 Schaft SK nach ISO 7388-1 Form AD Shank SK according to ISO 7388-1 Form AD

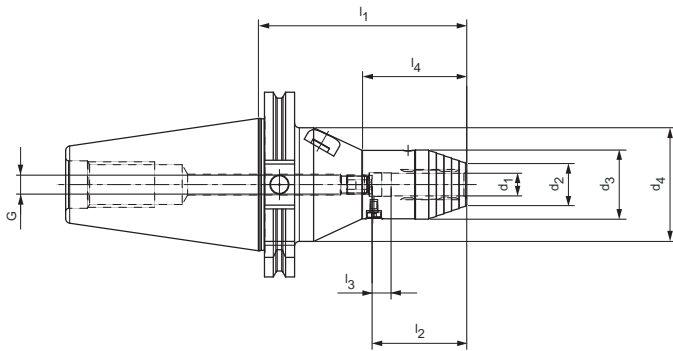

Auf Anfrage erhältlich Available on request

SK/ISO	Baumaße Dimensions								G	Bestell-Bezeichnung Order designation	Bestell-Nr. Order no.
	d ₁	d ₂	d ₃	d ₄	l ₁	l ₂	l ₃	l ₄			
50	6,0	18,0	32,0	60,0	110,0	43,0	10,0	45,0	M5	HC06-110-SK50	5223211
50	8,0	19,5	33,5	60,0	110,0	43,0	10,0	50,0	M6	HC08-110-SK50	5223212
50	10,0	21,0	35,0	60,0	110,0	43,0	10,0	50,0	M8x1	HC10-110-SK50	5223213
50	12,0	22,5	36,5	60,0	110,0	50,0	10,0	55,0	M10x1	HC12-110-SK50	5223214
50	14,0	24,0	38,0	60,0	110,0	50,0	10,0	60,0	M10x1	HC14-110-SK50	5223215
50	16,0	25,5	39,5	60,0	110,0	53,0	10,0	60,0	M12x1	HC16-110-SK50	5223217
50	18,0	27,0	41,0	60,0	110,0	53,0	10,0	60,0	M12x1	HC18-110-SK50	5223224
50	20,0	28,0	42,0	70,0	110,0	95,0	10,0	41,0	M16x1	HC20-110-SK50	5223225
50	22,0	30,0	44,0	70,0	110,0	95,0	10,0	43,0	M16x1	HC22-110-SK50	5223226
50	25,0	33,0	47,0	70,0	110,0	95,0	10,0	40,0	M16x1	HC25-110-SK50	5223227
50	32,0	40,0	54,0	70,0	110,0	95,0	10,0	56,0	M16x1	HC32-110-SK50	5223228

HC... SK, ISO 7388-1

Ultrakurze Ausführung Ultra-short version

Mit axialer Werkzeuglängeneinstellung With axial tool length adjustment

Schaft SK nach ISO 7388-1 Form AD/AF Shank SK according to ISO 7388-1 Form AD/AF

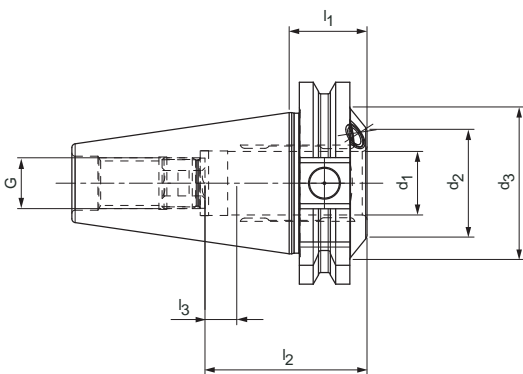

Lagerhaltige Vorzugsbaureihe Preferred series in stock

SK	Baumaße Dimensions						G	Bestell-Bezeichnung Order designation	Bestell-Nr. Order no.
	d ₁	d ₂	d ₃	l ₁	l ₂	l ₃			
40	20,0	34,0	48,0	24,5	51,0	10,0	M16x1	HC20-24,5-SK40	5223166

HC... BT, ISO 7388-2



Mit axialer Werkzeuglängeneinstellung With axial tool length adjustment
 Schaft BT nach ISO 7388-2 Form JD/JF (JIS B 6339)
 BT shank to ISO 7388-2 form JD/JF (JIS B 6339)

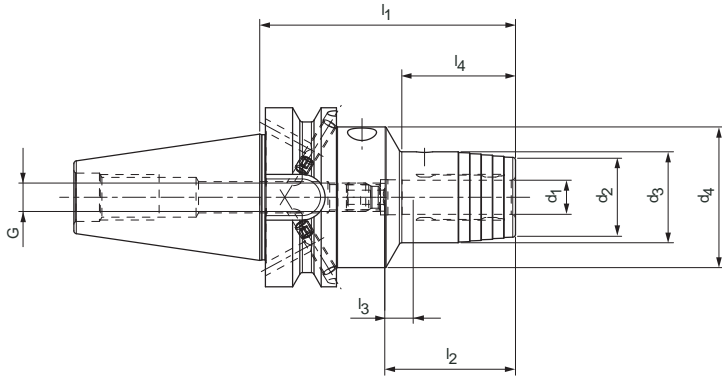

Lagerhaltige Vorzugsbaureihe Preferred series in stock

BT	Baumaße Dimensions								G	Bestell-Bezeichnung Order designation	Bestell-Nr. Order no.
	d ₁	d ₂	d ₃	d ₄	l ₁	l ₂	l ₃	l ₄			
30*	6,0	23,0	26,0	45,0	50,8	37,0	10,0	12,3	M5	HC06-50,8-BT30	5223070
30*	8,0	25,0	28,0	45,0	50,8	37,0	10,0	12,5	M6	HC08-50,8-BT30	5223071
30*	10,0	27,0	30,0	45,0	50,8	41,0	10,0	13,0	M8x1	HC10-50,8-BT30	5223099
30*	12,0	29,0	32,0	45,0	50,8	46,0	10,0	14,0	M8x1	HC12-50,8-BT30	5223100
30*	14,0	30,0	34,0	45,0	90,0	46,0	10,0	45,0	M8x1	HC14-90-BT30	5223101
30*	16,0	34,0	38,0	45,0	90,0	49,0	10,0	50,0	M8x1	HC16-90-BT30	5223103
30*	18,0	36,0	40,0	45,0	90,0	49,0	10,0	50,0	M8x1	HC18-90-BT30	5223104
30*	20,0	38,0	42,0	45,0	90,0	51,0	10,0	50,0	M8x1	HC20-90-BT30	5223105
40	6,0	22,0	26,0	49,5	90,0	37,0	10,0	29,0	M5	HC06-90-BT40	5223107
40	8,0	24,0	28,0	49,5	90,0	37,0	10,0	30,0	M6	HC08-90-BT40	5223108
40	10,0	26,0	30,0	49,5	90,0	41,0	10,0	35,0	M8x1	HC10-90-BT40	5223110
40	12,0	28,0	32,0	49,5	90,0	46,0	10,0	40,0	M10x1	HC12-90-BT40	5223111
40	14,0	30,0	34,0	49,5	90,0	46,0	10,0	40,0	M10x1	HC14-90-BT40	5223113
40	16,0	34,0	38,0	49,5	90,0	49,0	10,0	45,0	M12x1	HC16-90-BT40	5223114
40	18,0	36,0	40,0	49,5	90,0	49,0	10,0	46,0	M12x1	HC18-90-BT40	5223115
40	20,0	38,0	42,0	49,5	90,0	51,0	10,0	47,0	M16x1	HC20-90-BT40	5223116
40	25,0	51,0	55,0	52,0	90,0	57,0	10,0	50,0	M16x1	HC25-90-BT40	5223117
40	32,0	59,0	63,0	62,0	90,0	61,0	10,0	48,0	M16x1	HC32-90-BT40	5223118
50	6,0	22,0	26,0	49,5	90,0	37,0	10,0	29,0	M5	HC06-90-BT50	5223122
50	8,0	24,0	28,0	49,5	90,0	37,0	10,0	30,0	M6	HC08-90-BT50	5223124
50	10,0	26,0	30,0	49,5	90,0	41,0	10,0	34,0	M8x1	HC10-90-BT50	5223125
50	12,0	28,0	32,0	49,5	90,0	46,0	10,0	34,0	M10x1	HC12-90-BT50	5223126
50	14,0	30,0	34,0	49,5	90,0	46,0	10,0	35,0	M10x1	HC14-90-BT50	5223127
50	16,0	34,0	38,0	49,5	90,0	49,0	10,0	35,0	M12x1	HC16-90-BT50	5223128
50	18,0	36,0	40,0	49,5	90,0	49,0	10,0	35,0	M12x1	HC18-90-BT50	5223129
50	20,0	38,0	42,0	49,5	90,0	51,0	10,0	35,0	M16x1	HC20-90-BT50	5223130
50	25,0	51,0	55,0	63,0	110,0	57,0	10,0	48,0	M16x1	HC25-110-BT50	5223131
50	32,0	59,0	63,0	70,0	110,0	61,0	10,0	50,0	M16x1	HC32-110-BT50	5223132

* Ausführung: Steilkegelgröße ist nicht in Kombi-Ausführung JD/JF erhältlich
 * Version: Steep taper size is not available in combination version JD/JF

HCP.. BT, ISO 7388-2



Kurze schwere Ausführung Short heavy-duty design

Mit axialer Werkzeuglängeneinstellung With axial tool length adjustment

Schaft BT nach ISO 7388-2 Form JD/JF (JIS B 6339) BT shank to ISO 7388-2 form JD/JF (JIS B 6339)

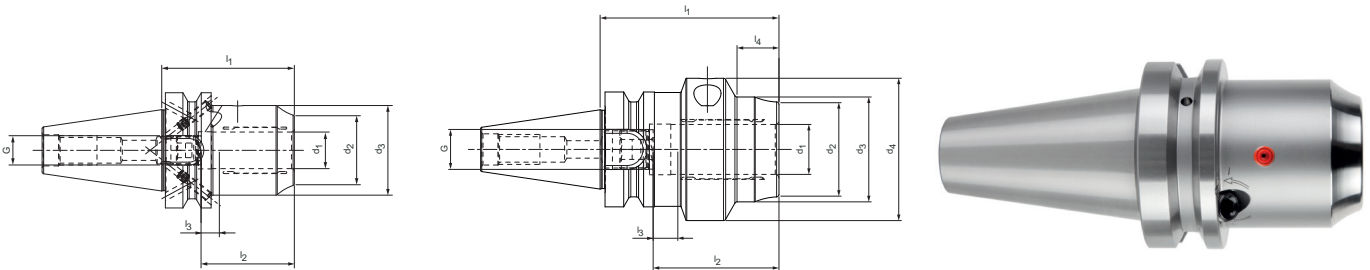

Lagerhaltige Vorzugsbaureihe Preferred series in stock

BT	Baumaße Dimensions								G	Bestell-Bezeichnung Order designation	Bestell-Nr. Order no.
	d ₁	d ₂	d ₃	d ₄	l ₁	l ₂	l ₃	l ₄			
30*	12,0	32,0	42,0	-	58,0	46,0	10,0	-	M8x1	HCP12-58-BT30	5222921
30*	20,0	38,0	42,0	57,0	72,5	51,0	10,0	17,0	M16x1	HCP20-72,5-BT30	5222922
40	12,0	32,0	42,0	-	58,0	46,0	10,0	-	M8x1	HCP12-58-BT40	5222923
40	20,0	38,0	49,0	-	72,5	51,0	10,0	-	M16x1	HCP20-72,5-BT40	5222924
40	32,0	54,0	63,0	62,0	90,0	61,0	10,0	-	M16x1	HCP32-90-BT40	5222925
50	12,0	32,0	42,0	-	69,0	46,0	10,0	-	M8x1	HCP12-69-BT40	5222926
50	20,0	38,0	49,0	-	83,5	51,0	10,0	-	M16x1	HCP20-83,5-BT40	5222927
50	32,0	57,0	68,0	72,0	90,0	61,0	10,0	35,0	M16x1	HCP32-90-BT40	5222929

* Ausführung: Steilkegelgröße ist nicht in Kombi-Ausführung JD/JF erhältlich.

* Version: Steep taper size is not available in combination version JD/JF.

Besuchen Sie unseren onlineshop unter <https://shop.bilz.de>

Visit our online store at <https://shop.bilz.de>



HCS... BT, ISO 7388-2



Schlanke Ausführung 3° Slim design 3°

Mit axialer Werkzeuflängeneinstellung With axial tool length adjustment

Schaft BT nach ISO 7388-2 Form JD/JF (JIS B 6339) BT shank to ISO 7388-2 form JD/JF (JIS B 6339)

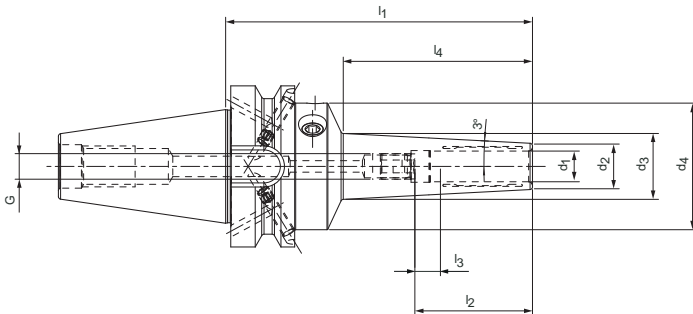

Lagerhaltige Vorzugsbaureihe Preferred series in stock

BT	Baumaße Dimensions								G	Bestell-Bezeichnung Order designation	Bestell-Nr. Order no.
	d ₁	d ₂	d ₃	d ₄	l ₁	l ₂	l ₃	l ₄			
30°	3,0	10,0	14,8	40,0	85,0	28,0	16,0	45,0	M2,5	HCS03-85-BT30	5222820
30°	4,0	12,0	16,8	40,0	85,0	28,0	12,0	45,0	M2,5	HCS04-85-BT30	5222822
30°	5,0	13,0	17,8	40,0	85,0	28,0	8,0	45,0	M2,5	HCS05-85-BT30	5222823
30°	6,0	14,0	18,9	40,0	85,0	37,0	10,0	46,0	M5	HCS06-85-BT30	5222826
30°	8,0	16,0	20,9	40,0	85,0	37,0	10,0	46,0	M6	HCS08-85-BT30	5222827
30°	10,0	18,0	23,0	40,0	85,0	41,0	10,0	47,0	M8x1	HCS10-85-BT30	5222830
30°	12,0	20,0	25,0	40,0	85,0	46,0	10,0	47,0	M8x1	HCS12-85-BT30	5222831
30°	14,0	24,0	29,0	40,0	85,0	46,0	10,0	47,0	M8x1	HCS14-85-BT30	5222832
30°	16,0	26,0	31,1	40,0	85,0	49,0	10,0	48,0	M8x1	HCS16-85-BT30	5222834
30°	18,0	28,0	33,1	40,0	85,0	49,0	10,0	48,0	M8x1	HCS18-85-BT30	5222835
30°	20,0	30,0	35,2	40,0	85,0	51,0	10,0	49,0	M8x1	HCS20-85-BT30	5222836
40	3,0	9,0	16,6	49,5	120,0	28,0	16,0	72,0	M2,5	HCS03-120-BT40	5222837
40	4,0	10,0	17,6	49,5	120,0	28,0	12,0	72,0	M2,5	HCS04-120-BT40	5222838
40	5,0	11,0	18,6	49,5	120,0	28,0	8,0	72,0	M2,5	HCS05-120-BT40	5222839
40	6,0	12,0	19,6	49,5	120,0	37,0	10,0	72,0	M5	HCS06-120-BT40	5222840
40	8,0	14,0	21,6	49,5	120,0	37,0	10,0	72,0	M6	HCS08-120-BT40	5222841
40	10,0	16,0	23,7	49,5	120,0	41,0	10,0	73,0	M8x1	HCS10-120-BT40	5222842
40	12,0	18,0	25,8	49,5	120,0	46,0	10,0	74,0	M10x1	HCS12-120-BT40	5222843
40	14,0	22,0	29,5	49,5	120,0	46,0	10,0	71,0	M10x1	HCS14-120-BT40	5222844
40	16,0	24,0	31,5	49,5	120,0	49,0	10,0	71,0	M12x1	HCS16-120-BT40	5222845
40	18,0	26,0	33,6	49,5	120,0	49,0	10,0	72,0	M12x1	HCS18-120-BT40	5222846
40	20,0	28,0	35,6	49,5	120,0	51,0	10,0	72,0	M16x1	HCS20-120-BT40	5222847

* Ausführung: Steilkegelgröße ist nicht in Kombi-Ausführung JD/JF erhältlich.

* Version: Steep taper size is not available in combination version JD/JF.

Maßangaben in mm.

Zubehör und Ersatzteile siehe Seite 25

Weitere Abmessungen und Sonderausführungen auf Anfrage.

Dimensions in mm.

For accessories and spare parts, see page 25

Other dimensions and special designs on request.

HCS... BT, ISO 7388-2



Schlanke Ausführung 3°, optimierte Kontur für maximale Biegesteifigkeit

Slim design 3°, optimised contour for maximum bending stiffness

Mit axialer Werkzeuglängeneinstellung With axial tool length adjustment

Schaft BT nach ISO 7388-2 Form JD/JF (JIS B 6339) BT shank to ISO 7388-2 form JD/JF (JIS B 6339)

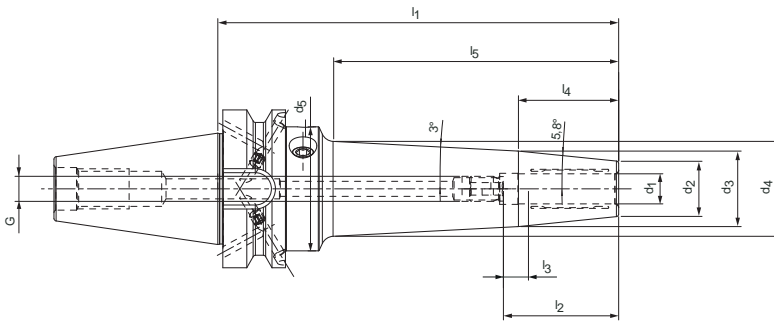

Lagerhaltige Vorzugsbaureihe Preferred series in stock

BT	Baumaße Dimensions								G	Bestell-Bezeichnung Order designation	Bestell-Nr. Order no.
	d ₁	d ₂	d ₃	d ₄	l ₁	l ₂	l ₃	l ₄			
40	3,0	13,0	31,4	49,5	160,0	28,0	16,0	109,0	M2,5	HCS03-160-BT40	5222848
40	3,0	13,0	35,7	49,5	200,0	28,0	16,0	150,0	M2,5	HCS03-200-BT40	5222849
40	4,0	14,0	32,4	49,5	160,0	28,0	12,0	109,0	M2,5	HCS04-160-BT40	5222850
40	4,0	14,0	36,7	49,5	200,0	28,0	12,0	150,0	M2,5	HCS04-200-BT40	5222851
40	5,0	15,0	33,4	49,5	160,0	28,0	8,0	109,0	M2,5	HCS05-160-BT40	5222852
40	5,0	15,0	37,7	49,5	200,0	28,0	8,0	150,0	M2,5	HCS05-200-BT40	5222853
40	6,0	16,0	33,6	49,5	160,0	37,0	10,0	111,0	M5	HCS06-160-BT40	5222854
40	6,0	16,0	37,9	49,5	200,0	37,0	10,0	152,5	M5	HCS06-200-BT40	5222855
40	8,0	18,0	34,7	49,5	160,0	37,0	10,0	111,5	M6	HCS08-160-BT40	5222856
40	8,0	18,0	39,0	49,5	200,0	37,0	10,0	152,5	M6	HCS08-200-BT40	5222857
40	10,0	20,0	36,3	49,5	160,0	41,0	10,0	113,0	M8x1	HCS10-160-BT40	5222858
40	10,0	20,0	40,6	49,5	200,0	41,0	10,0	154,0	M8x1	HCS10-200-BT40	5222859
40	12,0	22,0	37,9	49,5	160,0	46,0	10,0	114,0	M10x1	HCS12-160-BT40	5222860
40	12,0	22,0	42,2	49,5	200,0	46,0	10,0	155,0	M10x1	HCS12-200-BT40	5222861
40	14,0	26,0	41,8	49,5	160,0	46,0	10,0	113,0	M10x1	HCS14-160-BT40	5222862
40	14,0	26,0	46,1	49,5	200,0	46,0	10,0	154,0	M10x1	HCS14-200-BT40	5222863
40	16,0	28,0	43,8	49,5	160,0	49,0	10,0	113,0	M12x1	HCS16-160-BT40	5222864
40	16,0	28,0	46,1	49,5	200,0	49,0	10,0	154,0	M12x1	HCS16-200-BT40	5222865
40	18,0	30,0	44,9	49,5	160,0	49,0	10,0	114,0	M12x1	HCS18-160-BT40	5222866
40	18,0	30,0	47,1	49,5	200,0	49,0	10,0	155,0	M12x1	HCS18-200-BT40	5222867
40	20,0	32,0	46,9	49,5	160,0	51,0	10,0	114,0	M16x1	HCS20-160-BT40	5222868
40	20,0	32,0	46,9	49,5	200,0	51,0	10,0	155,0	M16x1	HCS20-200-BT40	5222869

Maßangaben in mm.

Zubehör und Ersatzteile siehe Seite 25

Weitere Abmessungen und Sonderausführungen auf Anfrage.

Dimensions in mm.

For accessories and spare parts, see page 25

Other dimensions and special designs on request.

Hydro-Dehnspannfutter



Ultrakurze Ausführung Ultra-short version

Mit axialer Werkzeuglängeneinstellung With axial tool length adjustment

Schaft BT nach ISO 7388-2 Form JD (JIS B 6339) BT shank to ISO 7388-2 form JD (JIS B 6339)

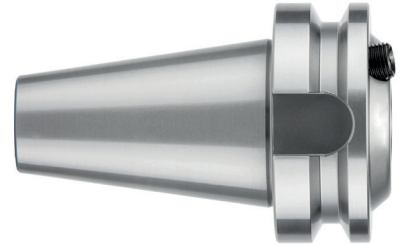
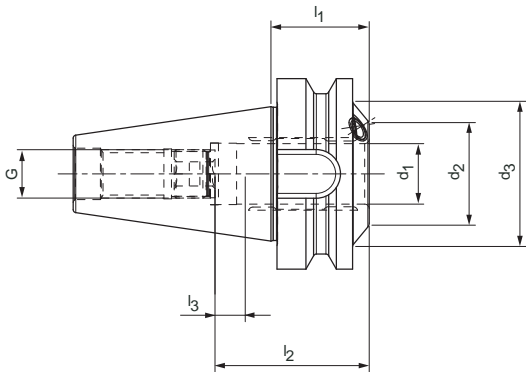

Lagerhaltige Vorzugsbaureihe Preferred series in stock

BT	Baumaße Dimensions						G	Bestell-Bezeichnung	Bestell-Nr. Order no.
	d ₁	d ₂	d ₃	l ₁	l ₂	l ₃			
40	20,0	38,0	48,0	32,5	51,0	10,0	M16x1	HC20-32,5-BT40	5223167

Besuchen Sie unseren onlineshop unter <https://shop.bilz.de>

Visit our online store at <https://shop.bilz.de>



HCP... FBT, ISO 7388-2



Kurze schwere Ausführung Short heavy-duty design

Mit axialer Werkzeuglängeneinstellung With axial tool length adjustment

Schaft ähnlich ISO 7388-2 Form JD (mit Plananlage) Shank similar to ISO 7388-2 form JD (with face contact)

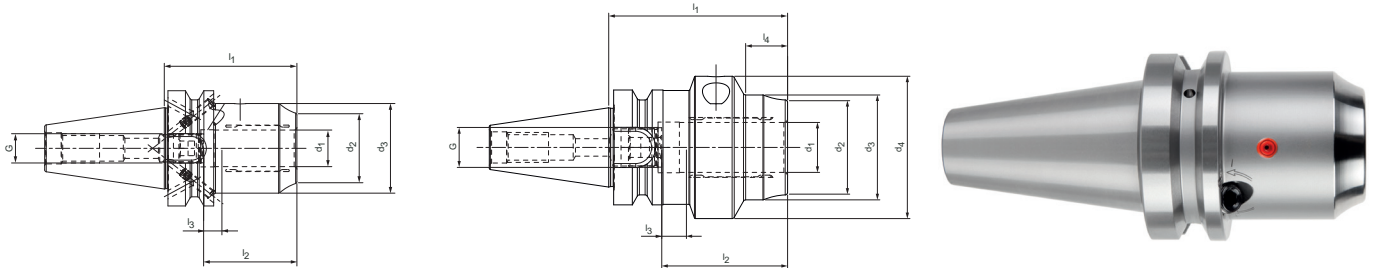

Lagerhaltige Vorzugsbaureihe Preferred series in stock

BT-FC	Baumaße Dimensions								G	Bestell-Bezeichnung Order designation	Bestell-Nr. Order no.
	d ₁	d ₂	d ₃	d ₄	l ₁	l ₂	l ₃	l ₄			
30	12,0	32,0	42,0	-	58,0	46,0	10,0	-	M8x1	HCP12-58-FBT30	5222930
30	20,0	38,0	42,0	57,0	72,5	51,0	10,0	17,0	M16x1	HCP20-72,5-FBT30	5222931
40	12,0	32,0	42,0	-	58,0	46,0	10,0	-	M8x1	HCP12-58-FBT40	5222932
40	20,0	38,0	49,0	-	72,5	51,0	10,0	-	M16x1	HCP20-72,5-FBT40	5222934
40	32,0	54,0	62,0	63,0	90,0	61,0	10,0	48,0	M16x1	HCP32-90-FBT40	5222936
50	12,0	32,0	42,0	-	69,0	46,0	10,0	-	M8x1	HCP12-69-FBT50	5222937
50	20,0	38,0	49,0	-	83,5	51,0	10,0	-	M16x1	HCP20-83,5-FBT50	5222938
50	32,0	57,0	68,0	72,0	90,0	61,0	10,0	35,0	M16x1	HCP32-90-FBT50	5222939

Maßangaben in mm.

Zubehör und Ersatzteile siehe Seite 25

Weitere Abmessungen und Sonderausführungen auf Anfrage.

Dimensions in mm.

For accessories and spare parts, see page 25

Other dimensions and special designs on request.

HCS... FBT, ISO 7388-2



Schlanke Ausführung 3° Slim design 3°

Mit axialer Werkzeuglängeneinstellung With axial tool length adjustment

Schaft ähnlich ISO 7388-2 Form JD (mit Plananlage) Shank similar to ISO 7388-2 form JD (with face contact)

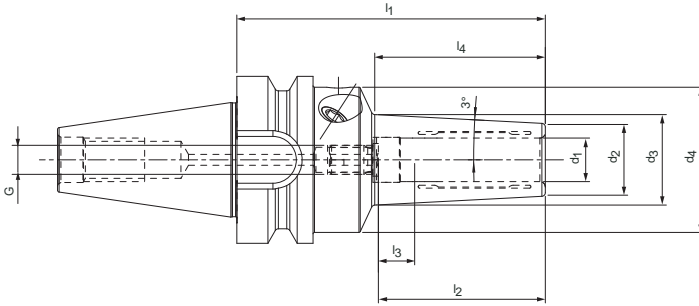

Lagerhaltige Vorzugsbaureihe Preferred series in stock

BT-FC	Baumaße Dimensions								G	Bestell-Bezeichnung Order designation	Bestell-Nr. Order no.
	d ₁	d ₂	d ₃	d ₄	l ₁	l ₂	l ₃	l ₄			
30	3,0	10,0	14,8	40,0	85,0	28,0	16,0	45,0	M2,5	HCS03-85-FBT30	5222870
30	4,0	12,0	16,8	40,0	85,0	28,0	12,0	45,0	M2,5	HCS04-85-FBT30	5222871
30	5,0	13,0	17,8	40,0	85,0	28,0	8,0	45,0	M2,5	HCS05-85-FBT30	5222872
30	6,0	14,0	18,9	40,0	85,0	37,0	10,0	46,0	M5	HCS06-85-FBT30	5222873
30	8,0	16,0	20,9	40,0	85,0	37,0	10,0	46,0	M6	HCS08-85-FBT30	5222874
30	10,0	18,0	23,0	40,0	85,0	41,0	10,0	47,0	M8x1	HCS10-85-FBT30	5222875
30	12,0	20,0	25,0	40,0	85,0	46,0	10,0	47,0	M8x1	HCS12-85-FBT30	5222889
30	14,0	24,0	29,0	40,0	85,0	46,0	10,0	47,0	M8x1	HCS14-85-FBT30	5222890
30	16,0	26,0	31,1	40,0	85,0	49,0	10,0	48,0	M8x1	HCS16-85-FBT30	5222891
30	18,0	28,0	33,1	40,0	85,0	49,0	10,0	48,0	M8x1	HCS18-85-FBT30	5222892
30	20,0	30,0	35,2	40,0	85,0	51,0	10,0	49,0	M8x1	HCS20-85-FBT30	5222893

HC... MOD, MN5000-14



Mit radial- und Winkelausrichtung und axialer Werkzeuglängeneinstellung

With radial and angular alignment and axial tool length adjustment

Modul - Anschlussmaße nach MN5000-14 Module - connection dimensions according to MN5000-14

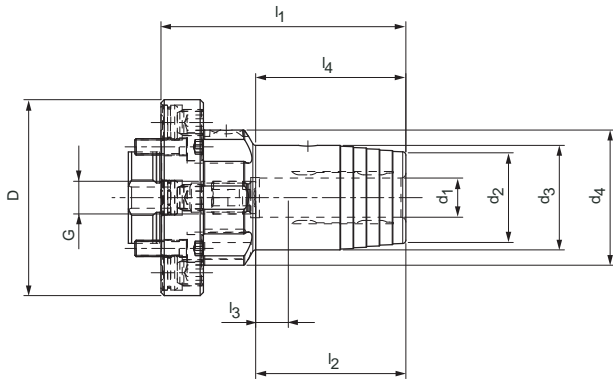

Lagerhaltige Vorzugsbaureihe Preferred series in stock

Aufnahme- durchmesser Modul D	Baumaße Dimensions								G	Bestell-Bezeichnung Order designation	Bestell-Nr. Order no.
	d ₁	d ₂	d ₃	d ₄	l ₁	l ₂	l ₃	l ₄			
60	6,0	22,0	26,0	42,0	65,0	37,0	10,0	34,0	M5	HC06-65-MOD60	5223134
60	8,0	24,0	28,0	42,0	65,0	37,0	10,0	35,0	M6	HC08-65-MOD60	5223135
60	10,0	26,0	30,0	42,0	70,0	41,0	10,0	40,0	M8x1	HC10-70-MOD60	5223136
60	12,0	28,0	32,0	42,0	75,0	46,0	10,0	46,0	M10x1	HC12-75-MOD60	5223137
80	12,0	28,0	32,0	50,0	77,5	46,0	10,0	41,5	M10x1	HC12-77,5-MOD80	5223138
80	16,0	34,0	38,0	50,0	82,5	49,0	10,0	47,5	M12x1	HC16-82,5-MOD80	5223139
80	20,0	38,0	42,0	50,0	82,5	51,0	10,0	50,0	M16x1	HC20-82,5-MOD80	5223140
100	25,0	53,0	57,0	63,0	100,0	57,0	10,0	61,0	M16x1	HC25-100-MOD100	5223141
117	32,0	60,0	64,0	75,0	103,0	61,0	10,0	61,0	M16x1	HC32-103-MOD117	5223142

Besuchen Sie unseren onlineshop unter <https://shop.bilz.de>

Visit our online store at <https://shop.bilz.de>



Modular Adapter HSK-A, DIN 69893-1

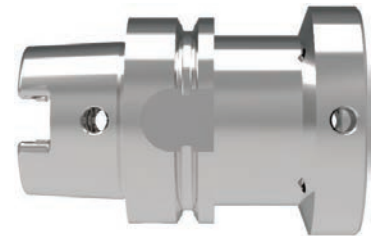
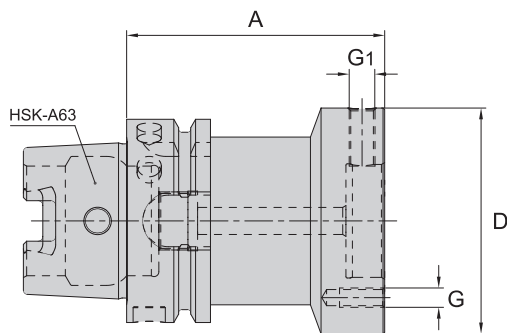

HSK-A	D (mm)	A (mm)	G	G1	N/W (Kg)	Bestell-Bezeichnung Order designation	Bestell-Nr. Order no.
63	60	60	M5	M8x1	1.3	MOD/60xD30xL60/HSK-A63	5166938
63	70	60	M6	M8x1	1.4	MOD/70xD35xL60/HSK-A63	5166939
63	80	60	M6	M8x1	1.5	MOD/80xD40xL60/HSK-A63	5166940
63	100	65	M8	M10x1	2.1	MOD/100xD50xL65/HSK-A63	5166941
63	117	65	M10	M10x1	2.5	MOD/117xD60xL65/HSK-A63	5166942

HSK-A	D (mm)	A (mm)	G	G1	N/W (Kg)	Bestell-Bezeichnung Order designation	Bestell-Nr. Order no.
100	60	55	M5	M8x1	2.8	MOD/60xD30xL55/HSK-A100	5166943
100	70	55	M6	M8x1	2.8	MOD/70xD35xL55/HSK-A100	5166944
100	80	55	M6	M8x1	3.0	MOD/80xD40xL55/HSK-A100	5166945
100	100	65	M8	M10x1	3.7	MOD/100xD50xL65/HSK-A100	5166946
100	117	65	M8	M10x1	4.0	MOD/117xD60xL65/HSK-A100	5166947
100	140	75	M10	M10x1	5.7	MOD/140xD80xL75/HSK-A100	5166948

Maßangaben in mm.
Zubehör und Ersatzteile siehe Seite 25
Weitere Abmessungen und Sonderausführungen auf Anfrage.

Dimensions in mm.
For accessories and spare parts, see page 25
Other dimensions and special designs on request.

Hydro-TurnChuck

Hydraulik Spanneinsatz für Drehmaschinen mit Innenkühlung
Hydraulic clamping insert for lathes with internal cooling

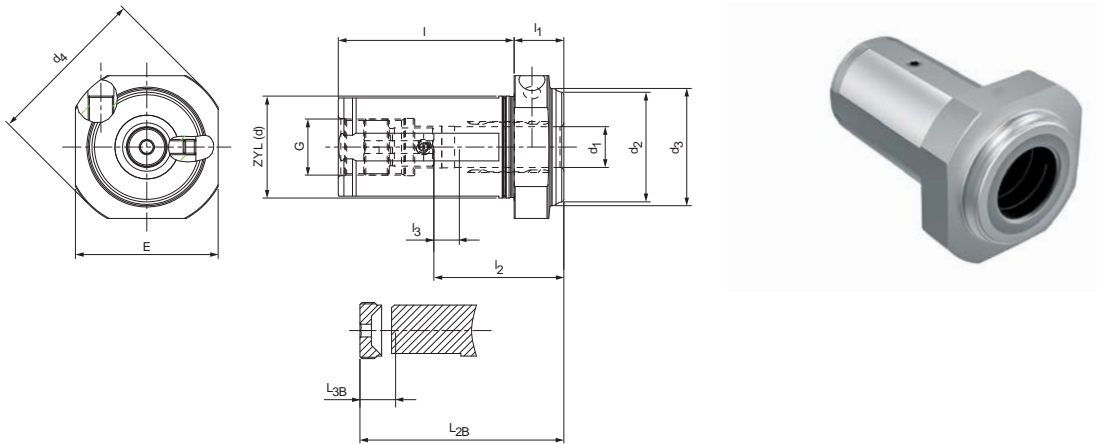

Auf Anfrage erhältlich Available on request

ZYL (d)	Baumaße Dimensions									G	L _{2B}	L _{3B}	Bestell-Bezeichnung Order designation	Bestell-Nr. Order no.
	d ₁	d ₂	d ₃	d ₄	E	l	l ₁	l ₂	l ₃					
32	16,0	38,0	41,0	59,0	50,0	59,0	19,5	51,0	10,0	M22x1	70	14	HC16-19,5-Z3200	5223181
32	20,0	38,0	41,0	59,0	50,0	59,0	19,5	51,0	10,0	M22x1	70	14	HC20-19,5-Z3200	5223182
40	16,0	43,0	46,0	64,0	56,0	69,0	19,5	51,0	10,0	M22x1	80	14	HC16-19,5-Z4000	5223183
40	20,0	43,0	46,0	64,0	56,0	69,0	19,5	51,0	10,0	M22x1	80	14	HC20-19,5-Z4000	5223184
40	25,0	43,0	46,0	64,0	56,0	69,0	19,5	57,0	10,0	M27x1	80	14	HC25-19,5-Z4000	5223186

Hydro-Dehnspannfutter VDI / DIN ISO 10889-1 für Drehmaschinen mit Innenkühlung
Hydraulic expansion chuck VDI / DIN ISO 10889-1 for lathes with internal cooling

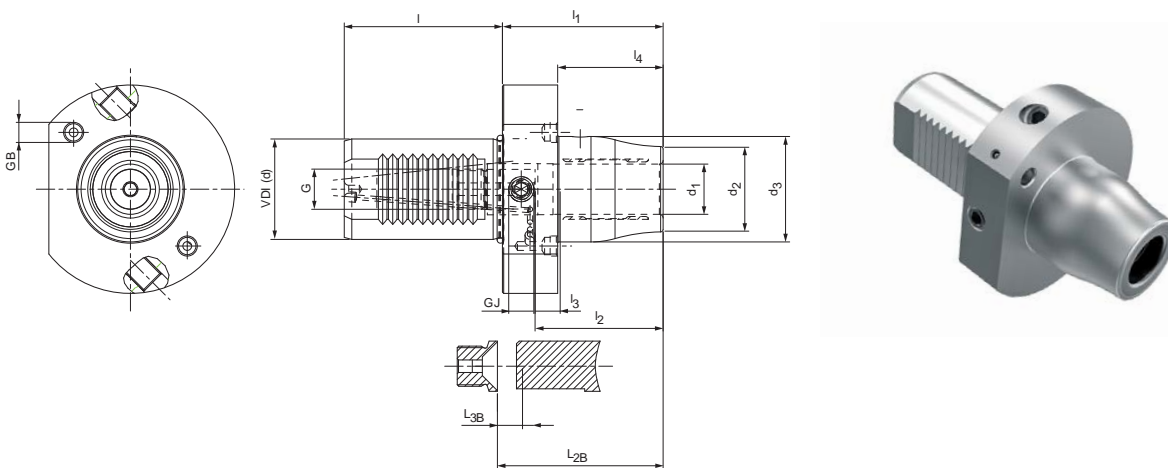

Auf Anfrage erhältlich Available on request

VDI (d)	Baumaße Dimensions									G	GJ	GB	L _{2B}	L _{3B}	Bestell-Bezeichnung Order designation	Bestell-Nr. Order no.
	d ₁	d ₂	d ₃	l	l ₁	l ₂	l ₃	l ₄								
32	20,0	34,0	42,0	55,0	64,0	51,0	10,0	42,0	M16x1	M10	M8x1	66	10	HC20-64-VDI32	5223187	
40	20,0	34,0	42,0	63,0	64,0	51,0	10,0	42,0	M16x1	M10	M8x1	66	10	HC20-64-VDI40	5223188	

Hydrodehnverlängerung Hydraulic extension



Als flexible Adaption As a flexible adaptation

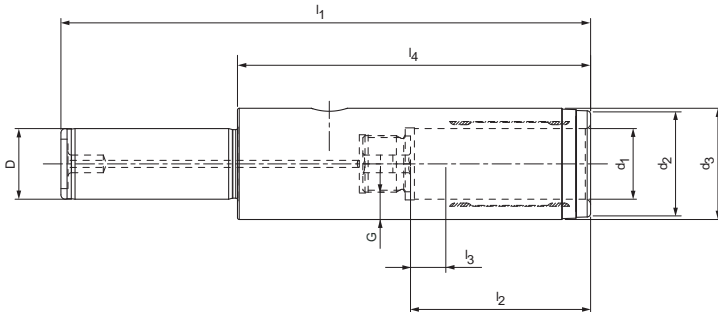

Lagerhaltige Vorzugsbaureihe Preferred series in stock

Aufnahmedurchmesser Zylinderschaft D	Baumaße Dimensions							G	Bestell-Bezeichnung Order designation	Bestell-Nr. Order no.
	d ₁	d ₂	d ₃	l ₁	l ₂	l ₃	l ₄			
20	12,0	22,0	25,0	150,0	46,0	10,0	100,0	M10x1	HC12-150-Z2000	5223189
20	20,0	30,0	31,5	150,0	51,0	10,0	100,0	M16x1	HC20-150-Z2000	5223190
32	20,0	30,0	31,5	150,0	51,0	10,0	90,0	M16x1	HC20-150-Z3200	5223191
32	20,0	30,0	31,5	200,0	51,0	10,0	90,0	M16x1	HC20-200-Z3200	5223192

Zubehör und Ersatzteile Accessories and spare parts

Montageschlüssel für Kühlmittelrohr
Installation wrench for coolant pipe

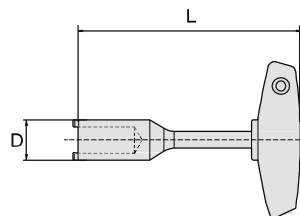

HSK-Größen HSK Size	D (mm)	L (mm)	Bestell-Nr. Ident no.
HSK 32	8.5	115	6738740
HSK 40	10.5	115	6738741
HSK 50	14.5	115	6738422
HSK 63	16.5	136	6738421
HSK 80	18.5	136	6738095
HSK 100	22.0	136	6738303

Reduzierbuchsen für Hydrodehnspannfutter

Reduction sleeves for Hydraulic expansion chuck



WHC - Reduzierbuchsen
WHC - Reduction sleeves

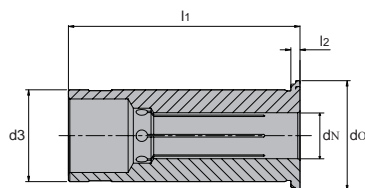

d1 (mm)	d2 (mm)	d3 (mm)	l1 (mm)	l2 (mm)	Innere Kühlmittelzufuhr / Internal coolant supply Bezeichnung / Designation	Bestell-Nr. Ident no.
3	19	12	45.0	2	WHC12-3	9142752
4	19	12	45.0	2	WHC12-4	9142753
5	19	12	45.0	2	WHC12-5	9142754
6	19	12	45.0	2	WHC12-6	9142755
8	19	12	45.0	2	WHC12-8	9142756
3	29	20	50,5	2	WHC20-3	9142758
4	29	20	50,5	2	WHC20-4	9142779
5	29	20	50,5	2	WHC20-5	9142780
6	29	20	50,5	2	WHC20-6	9142781
7	29	20	50,5	2	WHC20-7	9142782
8	29	20	50,5	2	WHC20-8	9142784
9	29	20	50,5	2	WHC20-9	9142785
10	29	20	50,5	2	WHC20-10	9142786
11	29	20	50,5	2	WHC20-11	9142787
12	29	20	50,5	2	WHC20-12	9142788
13	29	20	50,5	2	WHC20-13	9142799
14	29	20	50,5	2	WHC20-14	9142800
15	29	20	50,5	2	WHC20-15	9142801
16	29	20	50,5	2	WHC20-16	9142802
6	39	32	60,5	3	WHC32-6	9142804
8	39	32	60,5	3	WHC32-8	5069815
10	39	32	60,5	3	WHC32-10	9142809
12	39	32	60,5	3	WHC32-12	9142810
14	39	32	60,5	3	WHC32-14	9142811
16	39	32	60,5	3	WHC32-16	9142812
18	39	32	60,5	3	WHC32-18	9142813
20	39	32	60,5	3	WHC32-20	9142814
25	39	32	60,5	3	WHC32-25	9142815

WHC/WZ - Ausziehwerkzeug für Reduzierbuchsen
WHC/WZ - Sleeve remover

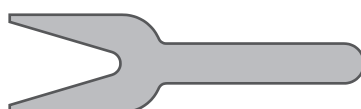

Bezeichnung Designation	Bestell-Nr. Ident no.
HGR/WZ	9142854

Anzugsbolzen MAS BT A+B

Pull stud MAS BT A+B



Type A (Ohne Durchgangsbohrung, ohne O-Ring)

Type A (Without trough hole, without O-ring)

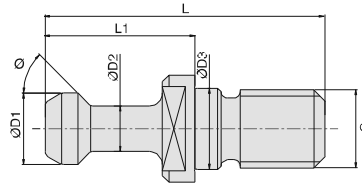

G	ØD1 (mm)	ØD2 (mm)	ØD3 (mm)	L (mm)	L1 (mm)	Ø	Bezeichnung / Designation	Bestell-Nr. Ident no.
M12	11.0	7.0	12.5	43.0	23.0	45°	BN 164 - BT 30	6733617
M16	15.0	10.0	17.0	60.0	35.0	45°	BN 164 - BT 40	6733618
M24	23.0	17.0	25.0	85.0	45.0	45°	BN 164 - BT 50	6733619
M12	11.0	7.0	12.5	43.0	23.0	60°	BN 164 - BT 30-60	4600614
M16	15.0	10.0	17.0	60.0	35.0	60°	BN 164 - BT 40-60	4600882
M24	23.0	17.0	25.0	85.0	45.0	60°	BN 164 - BT 50-60	4601402
M16	15.0	10.0	17.0	60.0	35.0	90°	BN 164 - BT 40-90	4600959
M24	23.0	17.0	25.0	85.0	45.0	90°	BN 164 - BT 50-90	4601404

Type B (mit Durchgangsbohrung, inkl. O-Ring)

Type A (with trough hole, incl. O-ring)

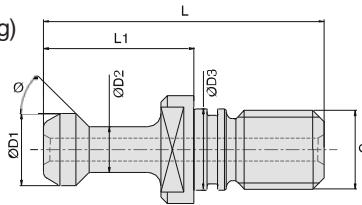

G	ØD1 (mm)	ØD2 (mm)	ØD3 (mm)	L (mm)	L1 (mm)	Ø	Bezeichnung / Designation	Bestell-Nr. Ident no.
M12	11.0	7.0	12.5	43.0	23.0	45°	BN 164B - BT 30	4600613
M16	15.0	10.0	17.0	60.0	35.0	45°	BN 164B - BT 40	4600957
M24	23.0	17.0	25.0	85.0	45.0	45°	BN 164B - BT 50	4601460
M12	11.0	7.0	12.5	43.0	23.0	60°	BN 164B - BT 30-60	5084973
M16	15.0	10.0	17.0	60.0	35.0	60°	BN 164B - BT 40-60	4600958
M24	23.0	17.0	25.0	85.0	45.0	60°	BN 164B - BT 50-60	4601461
M16	15.0	10.0	17.0	60.0	35.0	90°	BN 164B - BT 40-90	5084974
M24	23.0	17.0	25.0	85.0	45.0	90°	BN 164B - BT 50-90	4602462

Kühlmittelrohr für HSK-Spannfutter. Zur Kühlmittelübergabe bei HSK-Werkzeugen inkl. Runddichtung 01N 3770 und Überwurfmutter

Coolant tube for HSK chuck For coolant transfer in HSK tools incl. round gasket 01N 3770 and union nut

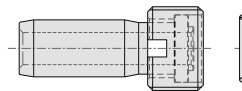

HSK-Größen HSK Size	Bezeichnung Designation	Bestell-Nr. Ident no.
HSK 32	UE4/HSK32	5064893
HSK 40	UE4/HSK40	5028425
HSK 50	UE4/HSK50	5028426
HSK 63	UE4/HSK63	5025376
HSK 80	UE4/HSK80	5028427
HSK 100	UE4/HSK100	5028428

Kundennähe und Innovationsgeist prägen unser Handeln seit 1919.



- Thermogrip® Schrumpfgeräte und Schrumpfspannfutter
- Gewindespanntechnik
- CNC Werkzeugaufnahmen
- Pendelhalter
- Sonderwerkzeuge
- Komplettanbieter für Werkzeugspanntechnik
- Kundenlösungen
- Ratschen und Druckluft
- SmartTools und Messtechnik
- Automation
- Sondergewindebohrer
- Montage

