

**boehlerit**

Ölfeldtechnologie  
Oilfield Technology

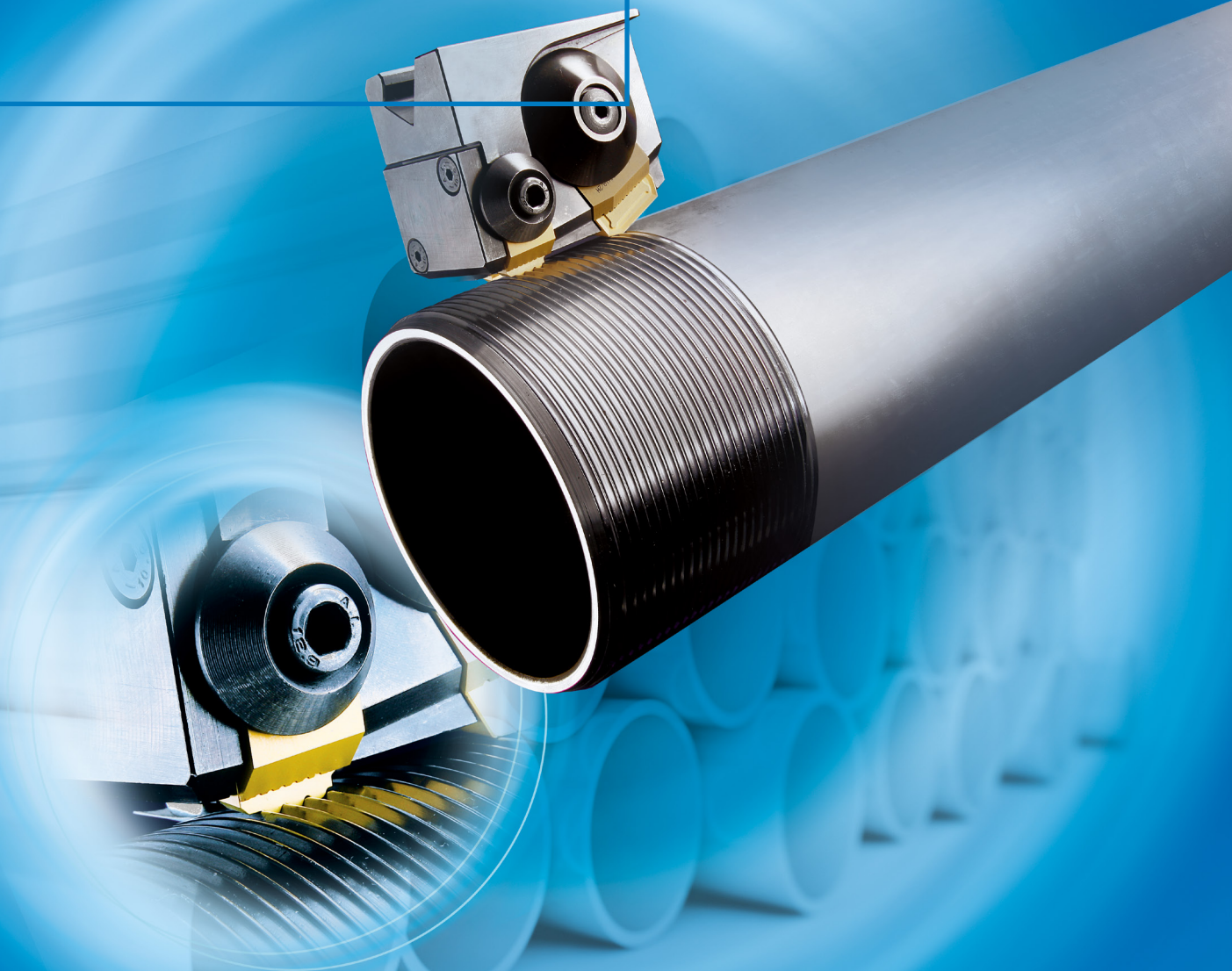

Wendeschneidplatten für das Schälen	Indexable inserts for roughturning	3
Wendeschneidplatten für das Gewinden, außen	Indexable inserts for threading, external	4
Wendeschneidplatten für das Gewinden, innen	Indexable inserts for threading, internal	5
Speziellösungen, innen	Special solutions, internal	5
Wendeschneidplatten für das Anfasen	Indexable inserts for chamfering	6
Positive und negative Wendeschneidplatten für Ölfeld	Positive and negative indexable inserts for oilfield	7
Sonderwerkzeuge für die Ölfeldbearbeitung	Special tools for oilfield machining	12
Schneidstoffsorten, Bezeichnung	Grade denomination	14
Sortenübersicht	Grade overview	15

### **Boehlerit – der Entwicklungspionier im Hartmetall**

Die Marke Boehlerit wurde 1932 für die Hartmetallfertigung der Firma Böhler in Düsseldorf gegründet. 1950 begann der Aufbau der Hartmetallfertigung in der österreichischen Stahlstadt Kapfenberg, wo sich heute der Hauptstandort der Boehlerit Gruppe befindet. Ein wesentlicher Meilenstein in der Boehlerit Geschichte war die 100%ige Übernahme der gesamten Boehlerit Gruppe durch den Leitz Firmenverband aus Oberkochen / Deutschland im Jahr 1991. Seitdem hat sich Boehlerit erfolgreich zum Schneidstoffzentrum der Leitz Firmengruppe entwickelt und zählt zu den weltweit führenden Herstellern von Schneidstoffen aus Hartmetall für Werkzeuge zur Holz-, Kunststoff- und Metallbearbeitung sowie von Werkzeugen zum Drehen, Fräsen, Bohren und Drehschälen. Eine weitere Stärke von Boehlerit sind Hartmetalle für Konstruktionsteile und für den Verschleißschutz.

Synergien zum Mutterkonzern und zu den Allianzpartnern werden zum Vorteil der weltweiten Kunden genutzt.

### **Boehlerit – Pioneers in Carbide Development**

The Boehlerit brand was established in 1932 for the carbide production of the Böhler company in Dusseldorf. 1950 was the beginning of carbide production in the Austrian steel town of Kapfenberg where the Boehlerit Group's headquarters are located today. The take-over of the entire Boehlerit Group by the Leitz Group from Oberkochen, Germany in 1991 marked an important milestone in the history of Boehlerit. Since its integration into the Leitz Group, Boehlerit has successfully developed into the group's centre for cutting materials. It is one of the world's leading producers of carbide cutting materials for tools for wood, plastic and metal cutting and tools for turning, milling, drilling and bar peeling. Carbide for structural parts and wear protection are yet another core competency of Boehlerit.

Synergies with our group companies and alliance partners, are utilised to the benefits of customers worldwide.





**Boehlerit Kapfenberg** in der Steiermark/Österreich, **Boehlerit Kapfenberg** in Styria/Austria





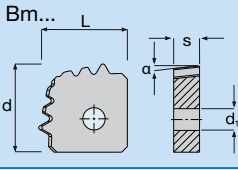

Bm... 	Bestellbezeichnung Ordering Code	L [mm]	d [mm]	s [mm]	d <sub>1</sub> [mm]	α [°]	Sorten Grades	
							LCP15T	LCP25T
Bm41767 	SCGX 2506	25,0	25,0	6,35	5,0	7	●	●
Bm53808 	SCGX 2506-OFB	25,0	25,0	6,35	5,0	7	●	●
Bm52897 	SCGX 2506-OFA	25,0	25,0	6,35	6,5	7	●	●

Bestellbeispiel Order Example: 10 Stück 10 pieces SCGX 2506 LCP15T

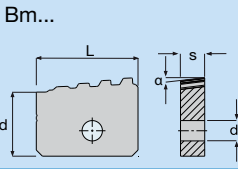
- Verfügbar ab Lager Available from stock
- Verfügbar auf Anfrage Available on request

**Wendeschneidplatten zum Außengewinde schneiden**  
**Indexable inserts for external threading**

	Bestellbezeichnung Ordering Code	L [mm]	d [mm]	s [mm]	d <sub>1</sub> [mm]	α [°]	Teeth	Sorten Grades
								BCP150
Bm52718 	API RD8 External	15,87	15,87	4,76	4,0	6	3	●



	Bestellbezeichnung Ordering Code	L [mm]	d [mm]	s [mm]	d <sub>1</sub> [mm]	α [°]	Teeth	Sorten Grades
								BCP150
Bm52696 	API-Buttress 5 TPI External	25,0	15,90	4,76	4,0	7	5	●
Bm53800 	GOST NKM 6 TPI External roughing	20,0	15,20	4,76	4,0	7	4	○
Bm53799 	GOST NKM 6 TPI External finishing	20,0	15,38	4,76	4,0	7	4	○
Bm53846 	API-Buttress 5 TPI External roughing	20,0	15,72	4,76	4,0	7	3	●
Bm53847 	API-Buttress 5 TPI External finishing	20,0	15,90	4,76	4,0	7	4	●

Bestellbeispiel Order Example: 10 Stück 10 pieces API RD8 External BCP150



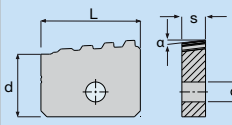

- Verfügbar ab Lager Available from stock
- Verfügbar auf Anfrage Available on request

**Wendeschneidplatten zum Innengewinde schneiden**  
**Indexable inserts for internal threading**

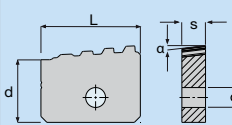

Bm...		Bestellbezeichnung Ordering Code	L [mm]	d [mm]	s [mm]	d <sub>1</sub> [mm]	α [°]	Teeth	Sorten Grades
									BCP150
Bm53315		API-Buttress 5 TPI Internal	25,00	15,90	5,0	4,0	7	5	●
									



**Sonderwendeschneidplatten, innen**  
**Special inserts, internal**

Bm...		Bestellbezeichnung Ordering Code	L [mm]	d [mm]	s [mm]	d <sub>1</sub> [mm]	α [°]	Teeth	Sorten Grades
									BCP150
Bm52731		Bm52731 5 TPI	15,9	15,75	5,0	4,0	7	2	○
									
Bm49056		Bm49056 6 TPI	15,9	15,75	5,0	4,0	7	1	○
									
Bm52730		Bm52730 8 TPI	15,9	15,75	5,0	4,0	7	1	○
									

Bestellbeispiel Order Example: 10 Stück 10 pieces API-Buttress 5 TPI Internal BCP150

- Verfügbar ab Lager Available from stock
- Verfügbar auf Anfrage Available on request

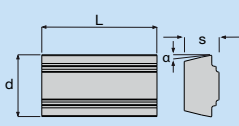
**Wendeschneidplatten zum Anfasen**  
**Indexable inserts for chamfering**

Bm... 	Bestellbezeichnung Ordering Code							Sorten Grades		
		L <sub>1</sub> [mm]	L [mm]	d [mm]	s [mm]	d <sub>1</sub> [mm]	α [°]	LC228E	LCP15T	LCP25T
Bm52177 	Bm52177	-	39,75	21,3	12,0	-	11	○		
Bm52178 	Bm52178	-	60,2	20,0	13,0	-	0	○		

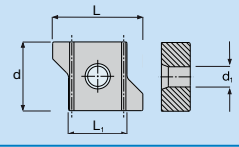
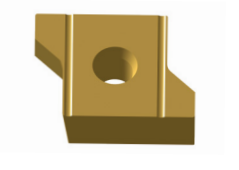
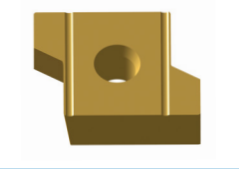
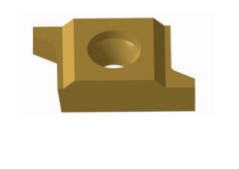

Bm... 	Bestellbezeichnung Ordering Code							Sorten Grades		
		L [mm]	L <sub>1</sub> [mm]	d [mm]	s [mm]	d <sub>1</sub> [mm]	α [°]	LC228E	LCP15T	LCP25T
Bm39658 45° 	Bm39658	25,0	16,2	19,0	8,0	5,6	7		●	●
Bm53763 60° 	Bm53763	25,0	16,2	19,0	8,0	5,6	7		●	●
Bm42421 60° 	Bm42421	23,3	16,8	13,7	6,4	5,6	7		●	●

Bestellbeispiel Order Example: 10 Stück 10 pieces Bm52177 LC228E

- Verfügbar ab Lager Available from stock
- Verfügbar auf Anfrage Available on request

**Positive und negative Wendeschneidplatten**  
**Positive and negative indexable inserts**

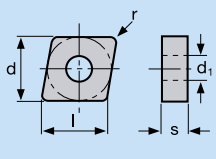

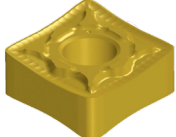
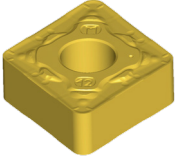
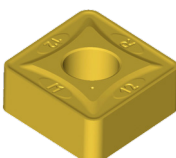
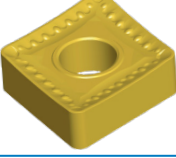
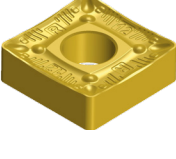



	Bestellbezeichnung Ordering code	l	d	s	d <sub>1</sub>	r	Sorte Grade		
							LCP15T	LCP25T	LC240F
	<b>CCMT 060202-MP</b>	6,40	6,35	2,38	2,80	0,2	●	●	
	<b>CCMT 060204-MP</b>	6,40	6,35	2,38	2,80	0,4	●	●	
	<b>CCMT 060208-MP</b>	6,40	6,35	2,38	2,80	0,8	●	●	
	<b>CCMT 09T304-MP</b>	9,70	9,52	3,97	4,40	0,4	●	●	
	<b>CCMT 09T308-MP</b>	9,70	9,52	3,97	4,40	0,8	●	●	
	<b>CCMT 120404-MP</b>	12,90	12,70	4,76	5,50	0,4	●	●	
	<b>CCMT 120408-MP</b>	12,90	12,70	4,76	5,50	0,8	●	●	
	<b>CNMG 120408-HPT</b>	12,90	12,70	4,76	5,16	0,8	●	●	
	<b>CNMG 120412-HPT</b>	12,90	12,70	4,76	5,16	1,2	●	●	
	<b>CNMG 090308-MP</b>	9,70	9,52	3,18	3,81	0,8	●	●	●
	<b>CNMG 120408-MP</b>	12,90	12,70	4,76	5,16	0,8	●	●	●
	<b>CNMG 120412-MP</b>	12,90	12,70	4,76	5,16	1,2	●	●	●
	<b>CNMG 120416-MP</b>	12,90	12,70	4,76	5,16	1,6	●	●	●
	<b>CNMG 160608-MP</b>	16,10	15,87	6,35	6,35	0,8	●	●	●
	<b>CNMG 160612-MP</b>	16,10	15,87	6,35	6,35	1,2	●	●	●
	<b>CNMG 160616-MP</b>	16,10	15,87	6,35	6,35	1,6	●	●	●
	<b>CNMG 190612-MP</b>	19,30	19,05	6,35	7,93	1,2	●	●	●
	<b>CNMG 190616-MP</b>	19,30	19,05	6,35	7,93	1,6	●	●	●
	<b>CNMG 120408-MRP</b>	12,90	12,70	4,76	5,16	0,8	●	●	●
	<b>CNMG 120412-MRP</b>	12,90	12,70	4,76	5,16	1,2	●	●	●
	<b>CNMG 120416-MRP</b>	12,90	12,70	4,76	5,16	1,6	●	●	●
	<b>CNMG 160608-MRP</b>	16,10	15,87	6,35	6,35	0,8	●	●	●
	<b>CNMG 160612-MRP</b>	16,10	15,87	6,35	6,35	1,2	●	●	●
	<b>CNMG 160616-MRP</b>	16,10	15,87	6,35	6,35	1,6	●	●	●
	<b>CNMG 190612-MRP</b>	19,30	19,05	6,35	7,93	1,2	●	●	●
	<b>CNMG 190616-MRP</b>	19,30	19,05	6,35	7,93	1,6	●	●	●
	<b>CNMM 160616-BR</b>	16,10	15,87	6,35	6,35	1,6			
	<b>CNMM 190616-BR</b>	19,30	19,05	6,35	7,93	1,6	●	●	●
	<b>CNMM 190624-BR</b>	19,30	19,05	6,35	7,93	2,4			
	<b>CNMM 120408-RP</b>	12,90	12,70	4,76	5,16	0,8	●	●	●
	<b>CNMM 120412-RP</b>	12,90	12,70	4,76	5,16	1,2	●	●	●
	<b>CNMM 160612-RP</b>	16,10	15,87	6,35	6,35	1,2	●	●	●
	<b>CNMM 160616-RP</b>	16,10	15,87	6,35	6,35	1,6	●	●	●
	<b>CNMM 190612-RP</b>	19,30	19,05	6,35	7,93	1,2	●	●	●
	<b>CNMM 190616-RP</b>	19,30	19,05	6,35	7,93	1,6	●	●	●
	<b>CNMM 190624-RP</b>	19,30	19,05	6,35	7,93	2,4	●	●	●

Bestellbeispiel Order Example: 10 Stück 10 pieces CCMT 060202-MP LCP15T

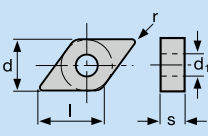
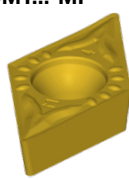
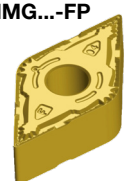
- Verfügbar ab Lager Available from stock
- Verfügbar auf Anfrage Available on request

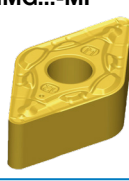
**Positive und negative Wendeschneidplatten**  
**Positive and negative indexable inserts**

	<b>Bestellbezeichnung</b> <b>Ordering code</b>	l	d	s	d <sub>1</sub>	r	Sorte Grade		
							LCP15T	LCP25T	LC240F
<b>DCMT...-MP</b> 	<b>DCMT 070204-MP</b>	7,70	6,35	2,38	2,80	0,4	●	●	
	<b>DCMT 11T304-MP</b>	11,60	9,52	3,97	4,40	0,4	●	●	
	<b>DCMT 11T308-MP</b>	11,60	9,52	3,97	4,40	0,8	●	●	
<b>DNMG...-FP</b> 	<b>DNMG 110404-FP</b>	11,60	9,52	4,76	3,97	0,4	●	●	
	<b>DNMG 110408-FP</b>	11,60	9,52	4,76	3,97	0,8	●	●	
	<b>DNMG 150404-FP</b>	15,50	12,70	4,76	5,16	0,4	●	●	
	<b>DNMG 150408-FP</b>	15,50	12,70	4,76	5,16	0,8	●	●	
	<b>DNMG 150604-FP</b>	15,50	12,70	6,35	5,16	0,4	●	●	
	<b>DNMG 150608-FP</b>	15,50	12,70	6,35	5,16	0,8	●	●	
<b>DNMG...-FMP</b> 	<b>DNMG 110404-FMP</b>	11,60	9,52	4,76	3,81	0,4	●	●	●
	<b>DNMG 110408-FMP</b>	11,60	9,52	4,76	3,81	0,8	●	●	
	<b>DNMG 150408-FMP</b>	15,50	12,70	4,76	5,16	0,8	●	●	
	<b>DNMG 150604-FMP</b>	15,50	12,70	6,35	5,16	0,4	●	●	●
	<b>DNMG 150608-FMP</b>	15,50	12,70	6,35	5,16	0,8	●	●	●
<b>DNMG...-HPT</b> 	<b>DNMG 150612-HPT</b>	15,50	12,70	6,35	5,16	1,2	●	●	
<b>DNMG...-MP</b> 	<b>DNMG 110408-MP</b>	11,60	9,52	4,76	3,97	0,8	●	●	●
	<b>DNMG 150408-MP</b>	15,50	12,70	4,76	5,16	0,8	●	●	●
	<b>DNMG 150412-MP</b>	15,50	12,70	4,76	5,16	1,2	●	●	●
	<b>DNMG 150608-MP</b>	15,50	12,70	6,35	5,16	0,8	●	●	●
	<b>DNMG 150612-MP</b>	15,50	12,70	6,35	5,16	1,2	●	●	●
	<b>DNMG 150616-MP</b>	15,50	12,70	6,35	5,16	1,6	●	●	●
<b>DNMG...-MRP</b> 	<b>DNMG 150408-MRP</b>	15,50	12,70	4,76	5,16	0,8	●	●	●
	<b>DNMG 150412-MRP</b>	15,50	12,70	4,76	5,16	1,2	●	●	●
	<b>DNMG 150608-MRP</b>	15,50	12,70	6,35	5,16	0,8	●	●	●
	<b>DNMG 150612-MRP</b>	15,50	12,70	6,35	5,16	1,2	●	●	●
	<b>DNMG 150616-MRP</b>	15,50	12,70	6,35	5,16	1,6	●	●	●
<b>DNMM...-RP</b> 	<b>DNMM 150608-RP</b>	15,50	12,70	6,35	5,16	0,8	●	●	●
	<b>DNMM 150612-RP</b>	15,50	12,70	6,35	5,16	1,2	●	●	●
	<b>DNMM 150616-RP</b>	15,50	12,70	6,35	5,16	1,6	●	●	●



Bestellbeispiel Order Example: 10 Stück 10 pieces DNMG 110404-FP LCP15T

- Verfügbar ab Lager Available from stock
- Verfügbar auf Anfrage Available on request



**Positive und negative Wendeschneidplatten**  
**Positive and negative indexable inserts**

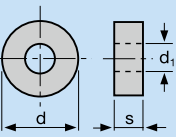

	Bestellbezeichnung Ordering code						Sorte Grade		
		l	d	s	d <sub>1</sub>	r	LCP15T	LCP25T	LC240F
<b>RCMX...</b> 	<b>RCMX 1003M0</b>	-	10,00	3,18	3,60	-			●
	<b>RCMX 1204M0</b>	-	12,00	4,76	4,20	-		●	●
	<b>RCMX 1606M0</b>	-	16,00	6,35	5,20	-	●	●	●
	<b>RCMX 2006M0</b>	-	20,00	6,35	6,50	-	●	●	●
	<b>RCMX 2507M0</b>	-	25,00	7,90	7,20	-	●	●	●
	<b>RCMX 3209M0</b>	-	32,00	9,52	9,50	-	●	●	●

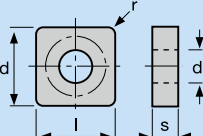
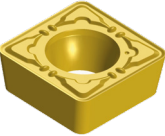
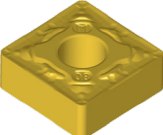
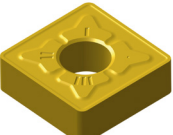
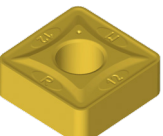
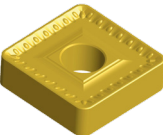
	Bestellbezeichnung Ordering code						Sorte Grade		
		l	d	s	d <sub>1</sub>	r	LCP15T	LCP25T	LC240F
<b>SCMT...-MP</b> 	<b>SCMT 09T308-MP</b>	9,52	9,52	3,97	4,40	0,8	●	●	
	<b>SCMT 120408-MP</b>	12,70	12,70	4,76	5,50	0,8	●	●	
	<b>SCMT 120412-MP</b>	12,70	12,70	4,76	5,50	1,2	●	●	
<b>SNMG...-MP</b> 	<b>SNMG 120408-MP</b>	12,70	12,70	4,76	5,16	0,8	●	●	●
	<b>SNMG 120412-MP</b>	12,70	12,70	4,76	5,16	1,2	●	●	●
	<b>SNMG 150608-MP</b>	15,87	15,87	6,35	6,35	0,8	●	●	●
	<b>SNMG 190612-MP</b>	19,05	19,05	6,35	7,93	1,2	●	●	●
<b>SNMG...-OFM</b> 	<b>SNMG 190612-OFM</b>	19,05	19,05	6,35	7,93	1,2	●	●	
<b>SNMG...-MRP</b> 	<b>SNMG 120408-MRP</b>	12,70	12,70	4,76	5,16	0,8	●	●	●
	<b>SNMG 120412-MRP</b>	12,70	12,70	4,76	5,16	1,2	●	●	●
	<b>SNMG 150608-MRP</b>	15,87	15,87	6,35	6,35	0,8	●	●	●
	<b>SNMG 150612-MRP</b>	15,87	15,87	6,35	6,35	1,2	●	●	●
	<b>SNMG 150616-MRP</b>	15,87	15,87	6,35	6,35	1,6	●	●	●
	<b>SNMG 190612-MRP</b>	19,05	19,05	6,35	7,93	1,2	●	●	●
	<b>SNMG 190616-MRP</b>	19,05	19,05	6,35	7,93	1,6	●	●	●
<b>SNMM...-BR</b> 	<b>SNMM 190616-BR</b>	19,05	19,05	6,35	7,93	1,6	●	●	●
	<b>SNMM 190624-BR</b>	19,05	19,05	6,35	7,93	2,4	●	●	●
	<b>SNMM 250724-BR</b>	25,40	25,40	7,94	9,12	2,4		●	●
	<b>SNMM 250924-BR</b>	25,40	25,40	9,52	9,12	2,4		●	●

Bestellbeispiel Order Example: 10 Stück 10 pieces RCMX 1003MO LCP15T

- Verfügbar ab Lager Available from stock
- Verfügbar auf Anfrage Available on request

**Positive und negative Wendeschneidplatten**  
**Positive and negative indexable inserts**

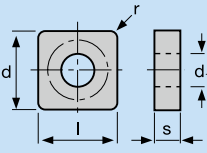
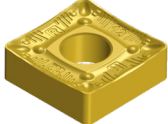
	Bestellbezeichnung Ordering code	l	d	s	d <sub>1</sub>	r	Sorte Grade		
							LCP15T	LCP25T	LC240F
<b>SNMM...-RP</b> 	<b>SNMM 120408-RP</b>	12,70	12,70	4,76	5,16	0,8	●	●	●
	<b>SNMM 120412-RP</b>	12,70	12,70	4,76	5,16	1,2	●	●	●
	<b>SNMM 150612-RP</b>	15,87	15,87	6,35	6,35	1,2	●	●	●
	<b>SNMM 150616-RP</b>	15,87	15,87	6,35	6,35	1,6	●	●	●
	<b>SNMM 190612-RP</b>	19,05	19,05	6,35	7,93	1,2	●	●	●
	<b>SNMM 190616-RP</b>	19,05	19,05	6,35	7,93	1,6	●	●	●
	<b>SNMM 190624-RP</b>	19,05	19,05	6,35	7,93	2,4	●	●	●
	<b>SNMM 190632-RP</b>	19,05	19,05	6,35	7,93	3,2		●	●
	<b>SNMM 250724-RP</b>	25,40	25,40	7,94	9,12	2,4		●	

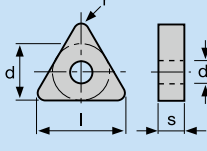
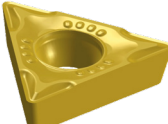
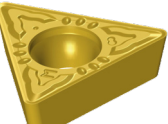
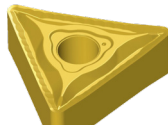
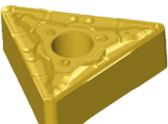
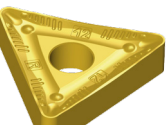

	Bestellbezeichnung Ordering code	l	d	s	d <sub>1</sub>	r	Sorte Grade		
							LCP15T	LCP25T	LC240F
<b>TCMT...-FP</b> 	<b>TCMT 110202-FP</b>	11,00	6,35	2,38	2,80	0,2	●	●	
	<b>TCMT 110204-FP</b>	11,00	6,35	2,38	2,80	0,4	●	●	
<b>TCMT...-MP</b> 	<b>TCMT 110204-MP</b>	11,00	6,35	2,38	2,80	0,4	●	●	
	<b>TCMT 110208-MP</b>	11,00	6,35	2,38	2,80	0,8	●	●	
	<b>TCMT 16T304-MP</b>	16,50	9,52	3,97	4,40	0,4	●	●	
	<b>TCMT 16T308-MP</b>	16,50	9,52	3,97	4,40	0,8	●	●	
<b>TNMG...-FMP</b> 	<b>TNMG 160404-FMP</b>	16,50	9,52	4,76	3,81	0,4	●	●	●
	<b>TNMG 160408-FMP</b>	16,50	9,52	4,76	3,81	0,8	●	●	●
	<b>TNMG 160412-FMP</b>	16,50	9,52	4,76	3,81	1,2		●	
<b>TNMG...-MP</b> 	<b>TNMG 160408-MP</b>	16,50	9,52	4,76	3,81	0,8	●	●	●
	<b>TNMG 160412-MP</b>	16,50	9,52	4,76	3,81	1,2	●	●	●
	<b>TNMG 160416-MP</b>	16,50	9,52	4,76	3,81	1,6	●	●	●
	<b>TNMG 220408-MP</b>	22,00	12,70	4,76	5,16	0,8	●	●	●
	<b>TNMG 220412-MP</b>	22,00	12,70	4,76	5,16	1,2	●	●	
<b>TNMM...-RP</b> 	<b>TNMM 160408-RP</b>	16,50	9,52	4,76	3,81	0,8	●	●	●
	<b>TNMM 220408-RP</b>	22,00	12,70	4,76	5,16	0,8	●	●	●
	<b>TNMM 220412-RP</b>	22,00	12,70	4,76	5,16	1,2	●	●	●



Bestellbeispiel Order Example: 10 Stück 10 pieces SNMM 120408-RP LCP15T

- Verfügbar ab Lager Available from stock
- Verfügbar auf Anfrage Available on request

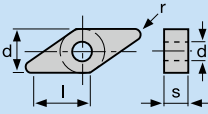
**Positive und negative Wendeschneidplatten**  
**Positive and negative indexable inserts**

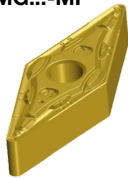

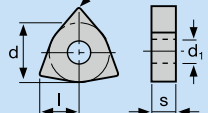
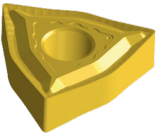
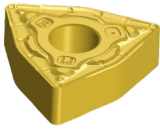
 <b>Bestellbezeichnung</b> <b>Ordering code</b>	l	d	s	d <sub>1</sub>	r	Sorte Grade			
						LCP15T	LCP25T	LC240F	
<b>VCMT...-MP</b> 	<b>VCMT 160404-MP</b>	16,60	9,52	4,76	3,81	0,4	●	●	
	<b>VCMT 160408-MP</b>	16,60	9,52	4,76	3,81	0,8	●	●	
<b>VNMG...-MP</b> 	<b>VNMG 160408-MP</b>	16,60	9,52	4,76	3,81	0,8	●	●	●
	<b>VNMG 160412-MP</b>	16,60	9,52	4,76	3,81	1,2	●	●	●

 <b>Bestellbezeichnung</b> <b>Ordering code</b>	l	d	s	d <sub>1</sub>	r	Sorte Grade			
						LCP15T	LCP25T	LC240F	
<b>WNMG...-FMP</b> 	<b>WNMG 060404-FMP</b>	6,50	9,52	4,76	3,81	0,4	●	●	●
	<b>WNMG 060408-FMP</b>	6,50	9,52	4,76	3,81	0,8	●	●	●
	<b>WNMG 080404-FMP</b>	8,60	12,70	4,76	5,16	0,4	●	●	●
	<b>WNMG 080408-FMP</b>	8,60	12,70	4,76	5,16	0,8	●	●	●
	<b>WNMG 080412-FMP</b>	8,60	12,70	4,76	5,16	1,2		●	
<b>WNMG...-MP</b> 	<b>WNMG 060408-MP</b>	6,50	9,52	4,76	3,81	0,8	●	●	●
	<b>WNMG 080408-MP</b>	8,60	12,70	4,76	5,16	0,8	●	●	●
	<b>WNMG 080412-MP</b>	8,60	12,70	4,76	5,16	1,2	●	●	●
	<b>WNMG 080416-MP</b>	8,60	12,70	4,76	5,16	1,6	●	●	
<b>WNMG...-MRP</b> 	<b>WNMG 080408-MRP</b>	8,60	12,70	4,76	5,16	0,8	●	●	●
	<b>WNMG 080412-MRP</b>	8,60	12,70	4,76	5,16	1,2	●	●	●
	<b>WNMG 080416-MRP</b>	8,60	12,70	4,76	5,16	1,6	●	●	●

Bestellbeispiel Order Example: 10 Stück 10 pieces VCMT 160404-MP LCP15T

- Verfügbar ab Lager Available from stock
- Verfügbar auf Anfrage Available on request

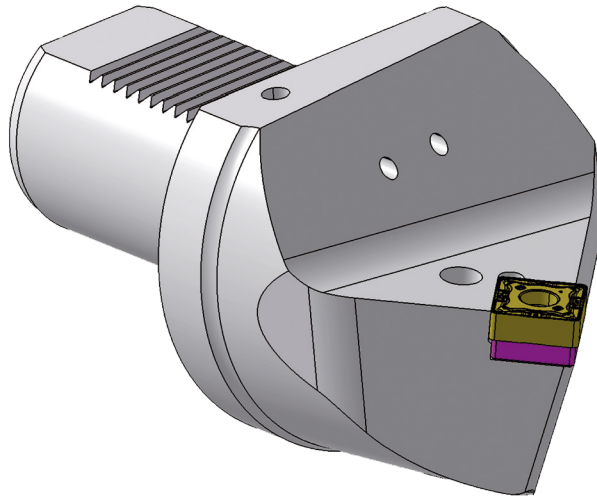

Fasen  
Chamfering

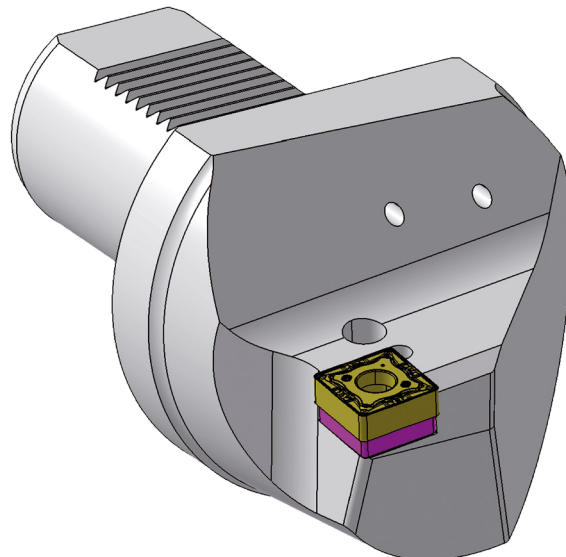

Plandrehen  
Planing

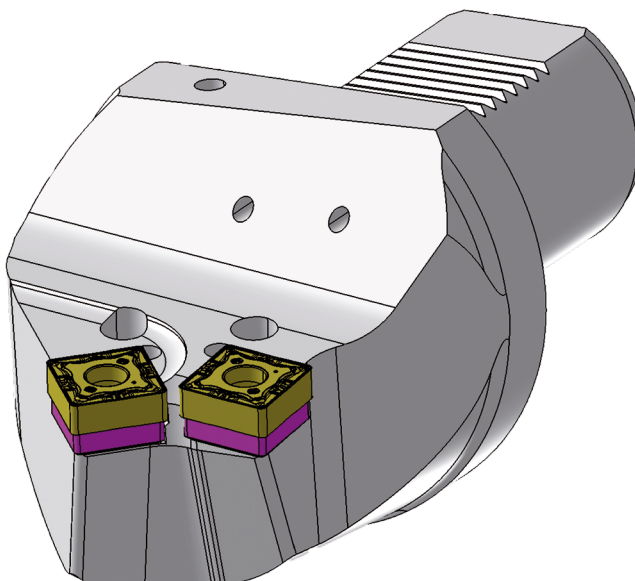

Plandrehen und Fasen  
Planing and chamfering

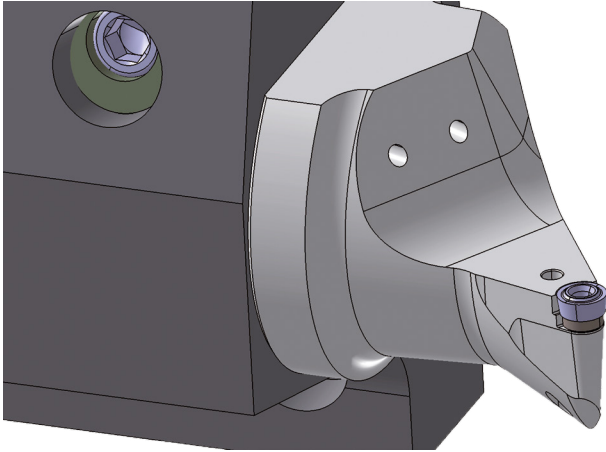

Kopieren  
Copying

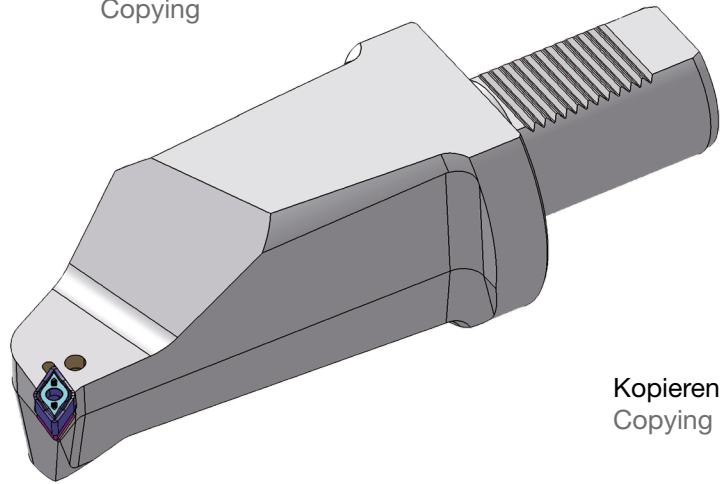

Kopieren  
Copying

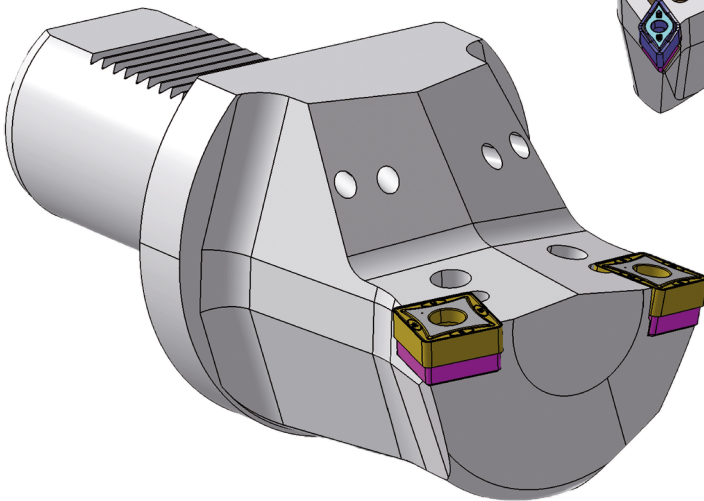

Schruppen innen und außen  
Internal and external roughing

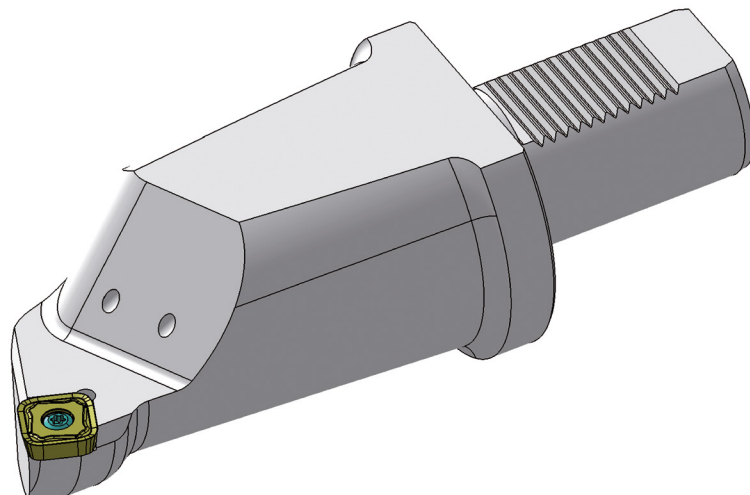

Schruppen - Schälen  
Roughing - Peeling

## Schneidstoffsorten, Bezeichnung Grade denomination

[www.boehlerit.com](http://www.boehlerit.com)

Der neue Sortenbezeichnungsschlüssel von Boehlerit stellt einen sprechenden Code dar und erleichtert somit die Zuordnung zur Anwendung.

The new grade designation system of Boehlerit is a “talking” code and makes allocation of code to application much easier.

## Stahlsorten BCP15O, LCP15T und LCP25T Steel grades BCP15O, LCP15T and LCP25T

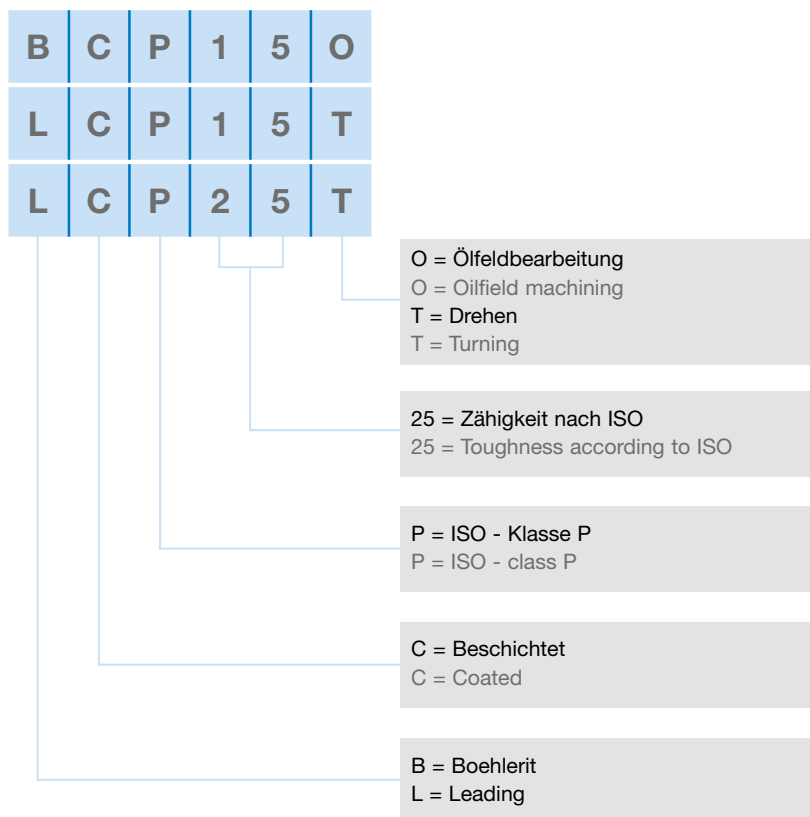

Sorte Grade	ISO	Anwendungsbereich Range of applications	Werkstoffgruppe Group of materials						Bearbeitungsverfahren Application						
			P Stahl Steel	M Rostfrei Stainless	K Grauguß Grey cast iron	N NE-Metalle (Al, etc.) Nonferrous metals	S Hochwarmfest High temper- ature materials	H Harte Werkstoffe Hard materials	T Drehen Turning	M Fräsen Milling	D Hobeln Scarfing	S Gewinde- bearbeitung Threading	G Einstechen Grooving	P Abstechen Parting	
LCP15T	HC-P15		■		□							●			
	HC-K15				□							●			
LCP25T	HC-P25		■									●			
	HC-M25			□								●			
LC240F	HC-P40		■									●			
	HC-M40			■								●			
BCP15O	HC-P15		■									●			
	HC-K15				□							●			
Anwendungsschwerpunkt Application peak  Gesamtbereich nach ISO 513 Full range to ISO 513		 01 05 10 15 20 25 30 35 40 45 50	■ Hauptanwendung Main application □ Weitere Anwendung Further applications						● Standardsorte Standard grade						

## Einsatzbereiche Fields of application

### LCP15T (HC-P15, HC-K15)

Drehsorte für Stahlwerkstoffe mit einer hohen Zugfestigkeit und hohe Bearbeitungstemperatur. Auch für das Gussdrehen geeignet.

### LCP15T (HC-P15, HC-K15)

Grade for steel materials with a high tensile strength and high temperature. Suitable for stainless steel application

### LCP25T (HC-P25, HC-M25)

(Universelle Drehsorte)  
Hauptsorte zum Drehen von Stahlwerkstoffen und leicht zerspanbarem rostbeständigem Stahl, bei mittleren Schnittgeschwindigkeiten, auch bei unterbrochenem Schnitt. Diese Mehrbereichssorte zeichnet sich durch hohe Verschleißfestigkeit und ausgezeichnete Zähigkeitseigenschaften in einem breiten Einsatzspektrum aus.

### LCP25T (HC-P25, HC-M25)

(Universal turning grade)  
Main grade for machining steel materials and easily machinable stainless steels at medium cutting speeds, included interrupted cut. This general purpose grade is characterized by the properties of high wear resistance and excellent characteristics across a wide range of applications.

### LC240F (HC-P40, HC-M40)

Sorte für die Bearbeitung von legiertem und unlegiertem Stahl bei mittleren Schnittgeschwindigkeiten. Die mehrlagige TiN TiCN Beschichtung ist auf einem äußerst zähen Basismaterial aufgebracht. Dieser Schneidstoff vereinigt somit die Verschleißbeständigkeit der Hartstoffbeschichtung mit der Schneidkantenstabilität und Ausbruchssicherheit des Substrates.

### LC240F (HC-P40, HC-M40)

Grade for machining alloyed and unalloyed steels at medium cutting speeds. The multilayer TiN TiCN coating is on a very tough base material. This grade has the wear resistance of the hard material coating as well as the cutting edge stability and breakage security of the substrate.

### BCP15O (P-15, K-15)

Beschichtete und verschleißfeste Stahlsorte für höchste Beanspruchung beim Gewindedrehen im Ölfeld.

### BCP15O (K-15, P-15)

Coated and wear resistant steel grade for highest demands for threading for oilfield machining.

**Boehlerit GmbH & Co. KG**  
Werk VI-Strasse 100  
8605 Kapfenberg  
Österreich/Austria  
Telefon +43 3862 300 - 0  
Telefax +43 3862 300 - 793  
info@boehlerit.com  
www.boehlerit.com

**boehlerit**

**Argentinien/Argentina**

SIN PAR S.A.  
Conesa 10  
B1878KSB Quilmes -  
Buenos Aires  
Telefon +54 11 4257 4396  
Telefax +54 11 4224 5687  
ventas@sinpar.com.ar  
www.sinpar.net  
www.boehlerit.com

**Brasilien/Brazil**

Boehlerit Brasil Ferramentas Ltda.  
Rua Capricórnio 72  
Alpha Conde I Comercial  
06473-005 - Barueri -  
São Paulo  
Telefon +55 11 554 60 755  
Telefax +55 11 554 60 476  
info@boehlerit.com.br  
www.boehlerit.com

**China/China**

Boehlerit China  
Swiss Center Shanghai  
Room A107, Building 3  
No. 526, 3rd East Fute Road  
Shanghai Pilot Free Trade Zone  
200131 P.R. China  
Telefon +86 137 358 950 58  
info@boehlerit.com.cn  
www.boehlerit.com

Golden Carbide (Shanghai) Co., Ltd  
Room 2101-2102, Gateway  
International Plaza Building A,  
No.325, Tian Yao Qiao Road,  
Shanghai China Zip:200030  
Telefon +86-21-33632088,33632099  
Telefax +86-21-33633303  
info@goldencarbide.com  
www.boehlerit.com

**Deutschland/Germany**

Boehlerit GmbH & Co. KG  
Werk VI-Strasse 100  
8605 Kapfenberg  
Österreich/Austria  
Telefon +43 3862 300-0  
Telefax +43 3862 300-793  
info@boehlerit.com  
www.boehlerit.com

**Dubai/Dubai**

HFD Electronic Spare Parts LLC  
The Curve Bldg. SZR  
Office M40, P.O. Box 6293  
Dubai, United Arab Emirates  
Telefon +971 4 380 7866  
Telefax +971 4 380 7867  
chris@hfdme.ae  
www.hfdme.com  
www.boehlerit.com

**Großbritannien/United Kingdom**

LMT UK Ltd  
4202 Waterside Centre,  
Solihull Parkway  
B37 7YN Birmingham  
Telefon +44 16 76 523440  
Telefax +44 16 76 525379  
lmt.uk@lmt-tools.com  
www.lmt-uk.co.uk  
www.boehlerit.com

**Finnland/Finland**

Oy Maanterä AB  
Keinumäenkuja 2, P.O. Box 70  
01510 Vantaa  
Telefon +358 29 006 130  
Telefax +358 29 006 1130  
maantera@maantera.fi  
www.maantera.fi  
www.boehlerit.com

**Frankreich/France**

LMT BELIN France S.A.S.  
Lieu dit «Les Cizes»  
F-01590 LAVANCIA  
Telefon +33 4 74 75 89 89  
Telefax +33 4 74 75 89 90  
info.fr@lmt-tools.com  
www.lmt-belin.com  
www.boehlerit.com

**Kanada/Canada**

Eagle Industrial Ltd.  
Dorian Tool Canada  
Box 55, GRP 582, RR 5  
UNIT 1 - 42 Matheson Parkway  
Winnipeg, Manitoba  
Canada R2C 2Z2  
Telefon +1 204 654-9894  
Telefax + 1 204 654-6080  
Toll Free: +1 866 460-4951  
www.eagleindustrial.ca  
www.boehlerit.com

**Indien/India**

Boehlerit GmbH & Co. KG  
Werk VI-Strasse 100  
8605 Kapfenberg  
Österreich/Austria  
Telefon +43 3862 300 - 0  
Telefax +43 3862 300 - 793  
info@boehlerit.com  
www.boehlerit.com

**Italien/Italy**

Boehlerit Italy S.r.l.  
Via Papa Giovanni XXIII, Nr. 45  
20090 Rodano (MI)  
Telefon +39 02 269 49 71  
Telefax +39 02 218 72 456  
info@boehlerit.it  
www.boehlerit.com

**Mexiko/Mexico**

Boehlerit S.A. de C.V.  
Av. Acueducto No. 15  
Parque Industrial Bernardo  
Quintana  
El Marqués, Querétaro  
México. C.P. 76246  
Telefon +52 442 221 5706  
Telefax +52 442 221 5555  
info@boehlerit.com.mx  
www.boehlerit.com

**Niederlande/Nederlande**

Hagro Precisie b.v.  
Industriepark 18  
NL-5374 CM Schaijk  
Telefon +31 486 462 424  
Telefax +31 486 461 650  
hagro@hagro.nl  
www.hagro.nl  
www.boehlerit.com

**Polen/Poland**

Boehlerit Polska sp.z.o.o.  
Złotniki, ul. Kobaltowa 6  
62-002 Suchy Las  
Telefon +48 61 659 38 00  
Telefax +48 61 623 20 14  
info@boehlerit.pl  
www.boehlerit.com

**Russland/Russia**

MWT-Engineering, Ltd.  
5, bld 10, 2nd Enthuziastov str.  
111024, Moscow  
Telefon +7 495 280 1854  
Telefax +7 495 222 5147  
info@mwt-engineering.ru  
www.mwt-engineering.ru  
www.boehlerit.com

**Schweden/Sweden  
Dänemark/Danmark**

Edeco Tool AB  
Gräsdalsgatan 9  
650 02 Karlstad  
Telefon +46 54 55 80 00  
Telefax +46 54 55 80 35  
info@edeco.se  
www.edeco.se  
www.boehlerit.com

**Schweiz/Switzerland**

Vargus Werkzeugtechnik Snel AG  
Knonauerstraße 56  
6330 Cham 1  
Telefon +41 41 784 21 21  
Telefax +41 41 784 21 39  
info@vargus.ch  
www.vargus.ch  
www.boehlerit.com

**Singapur/Singapore**

Boehlerit Asia Pte Ltd  
1 Clementi Loop 04-01  
Clementi West District Park  
Singapore 12 98 08  
Telefon +65 64 62 1608  
Telefax +65 64 62 4215  
info@boehleritasia.com  
www.boehlerit.com

**Slowakei/Slovakia**

Kancelár Boehlerit  
Santraziny 753  
760 01 Zlín  
Telefon +420 577 214 989  
Telefax +420 577 219 061  
boehlerit@boehlerit.sk  
www.boehlerit.cz  
www.boehlerit.com

**Slowenien/Slovenia**

KAČ trade d.o.o.  
Ložnica pri Žalcu 46  
3310 Žalec  
Telefon: +386 3 710 40 80  
Telefax: +386 3 710 40 81  
info@kactrade.si  
www.kactrade.com  
www.boehlerit.com

**Spanien/Spain**

Boehlerit Spain S.L.  
C/. Narcis Monturiol 11-15  
08339 Vilassar de Dalt Barcelona  
Telefon +34 93 750 7907  
Telefax +34 93 750 7925  
info@boehlerit.es  
www.boehlerit.com

**Taiwan/Taiwan**

Golden Hardpoint Inc.  
2F, No. 40, Tun Hua S. Road, Sec.2,  
Taipei ZIP: 106  
Telefon + 886-2-27058448A  
Telefax +886-2-27008430  
info@goldencarbide.com  
www.boehlerit.com

**Tschechien/  
Czech Republic**

Kancelár Boehlerit  
Santraziny 753  
760 01 Zlín  
Telefon +420 577 214 989  
Telefax +420 577 219 061  
boehlerit@boehlerit.cz  
www.boehlerit.cz  
www.boehlerit.com

**Türkei/Turkey**

Boehlerit  
Sert Metal ve Takım San. ve Tic. A.Ş.  
Gosb 1600. Sk.No: 1602  
41480 Gebze - Kocaeli  
Telefon +90 262 677 1737  
Telefax +90 262 677 1746  
info@boehlerit.com.tr  
www.boehlerit.com.tr  
www.boehlerit.com

**Ungarn/Hungary**

Boehlerit Hungária Kft.  
2036 Érdliget Pf. 32  
2030-Érd, Kis-Duna u.6.  
Telefon +36 23 521 915  
Telefax +36 23 521 919  
info@boehlerit.hu  
www.boehlerit.com

**USA**

Boehlerit USA  
1140 No.Main St.  
Lombard IL 60148  
Telefon +1 847 734 9390  
Telefax +1 847 734 9391  
www.boehlerit.com