

GESAMTKATALOG GENERAL CATALOGUE CATALOGUE GÉNÉRAL

K24





K KEMMLER®

Ein Unternehmen mit Geschichte und Tradition

KEMMLER® Präzisionswerkzeuge GmbH, das Familienunternehmen aus der baden-württembergischen Stadt Mössingen bei Stuttgart, entwickelt, fertigt und vertreibt innovative und hochpräzise Produkte rund um die Werkzeugmaschine.

Das international tätige Unternehmen wurde 1997 von Fritz Kemmler gegründet und wird mittlerweile in zweiter Generation von Jörg Kemmler geführt.

K KEMMLER®

A company with history and tradition

***KEMMLER®** Präzisionswerkzeuge GmbH, the family business at Mössingen near Stuttgart in Baden-Württemberg develops, manufactures and distributes innovative and high-precision products around the machine tools.*

The international acting company was founded in 1997 by Fritz Kemmler and is now run by the second generation of Jörg Kemmler.

K KEMMLER®

Une entreprise plein d'histoire et de tradition

KEMMLER® Präzisionswerkzeuge GmbH, une entreprise familiale située à Mössingen près de Stuttgart en Bade-Wurtemberg, développe, produit et distribue des produits innovants et précis pour machines outils.

Dès 1997 l'entreprise inaugurée par Fritz Kemmler est active dans le monde entier. Entre-temps ses fils Jörg Kemmler ont pris en charge la direction.



Familienwappen seit 1396

Family crest since 1396

Blason familial dès 1396

<p>Werkzeugaufnahmen DIN ISO 7388-1 (ehemals DIN 69871) <i>Toolholders DIN ISO 7388-1 (formerly DIN 69871)</i> Porte-outils DIN ISO 7388-1 (l'ancien DIN 69871)</p>	1
<p>Werkzeugaufnahmen DIN ISO 7388-2 (ehemals JIS B 6339 - MAS / BT) <i>Toolholders DIN ISO 7388-2 (formerly JIS B 6339 - MAS / BT)</i> Porte-outils DIN ISO 7388-2 (l'ancien JIS B 6339 - MAS / BT)</p>	2
<p>Werkzeugaufnahmen mit Plananlage / Doppelkontakt <i>Toolholders with face contact / Dual contact</i> Porte-outils avec plan de travail / Contact direct</p>	3
<p>Werkzeugaufnahmen DIN 2080 <i>Toolholders DIN 2080</i> Porte-outils DIN 2080</p>	4
<p>Werkzeugaufnahmen ISO 12164 und DIN 69893 (HSK-A HSK-E HSK-F) <i>Toolholders ISO 12164 und DIN 69893 (HSK-A HSK-E HSK-F)</i> Porte-outils ISO 12164 et DIN 69893 (HSK-A HSK-E HSK-F)</p>	5
<p>Werkzeugaufnahmen mit Polygonalschaft ISO 26623 <i>Toolholders with polygonal shank ISO 26623</i> Porte-outils à queue polygonale ISO 26623</p>	6
<p>Statische und angetriebene Werkzeuge für CNC-Drehmaschinen <i>Static and power-driven tools for CNC lathes and machining centers</i> Porte-outils statiques ou rotatifs pour tours CN</p>	7
<p>Werkzeugaufnahmen MK DIN 228-1 A und DIN 228-1 B <i>Toolholders MT DIN 228-1 A and DIN 228-1 B</i> Porte-outils CM DIN 228-1 A et DIN 228-1 B</p>	8
<p>Spannzangen <i>Collets</i> Pincés</p>	9
<p>Zubehör · Anzugsbolzen <i>Accessories · Pull studs</i> Accessoires · Tirettes</p>	10
<p>Präzisionsschraubstöcke <i>Precision vices</i> Eaux de précision</p>	11
<p>Messtechnik <i>Measuring technique</i> Métrologie</p>	12
<p>Technische Daten <i>Technical data</i> Données techniques</p>	13



K KEMMLER® *Fertigung Werkzeughalter*

Vom Schmiederohling bis hin zum Endprodukt erfolgen alle Bearbeitungsprozesse unter einem Dach. Nur so kann die 100% **KEMMLER®** Qualität erreicht werden.

Mit modernstem Maschinenpark der jüngsten Generation und sehr hohem Automatisierungsgrad bei großer Fertigungstiefe werden mehr als 40.000 Werkzeughalter im Monat produziert.

K KEMMLER® *Toolholder production*

*From the forging blank to the final product all working processes take place under the same roof. Just this way the 100% **KEMMLER®** quality can be achieved.*

With modern machinery of the latest generation and a very high degree of automation in a large vertical range of manufacture more than 40.000 toolholders are produced every month.

K KEMMLER® *Fabrication de porte-outils*

De l'ébauche de forge au produit fini tous les processus d'usinage ont lieu sous le même toit. Seulement ainsi la qualité **KEMMLER®** de 100% peut être obtenue.

Avec des machines modernes de la dernière génération et de très haut degré d'automatisation dans une large portée verticale de fabrication plus de 40.000 porte-outils sont produits par mois.

Schmieden

Forging

Forger

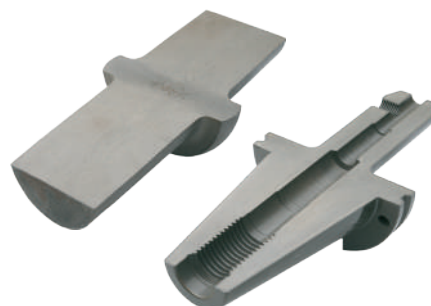

Fräsen und Drehen

Milling and Turning

Fraisage et Tournasage

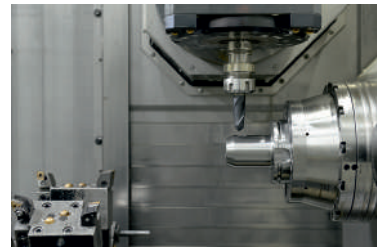
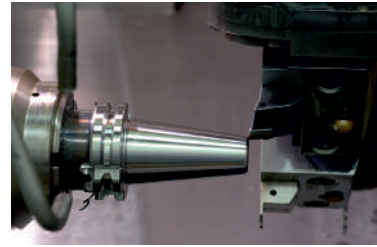
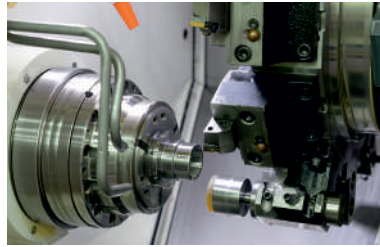
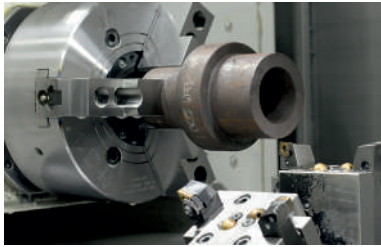

Schleifen

Grinding

Affûtage

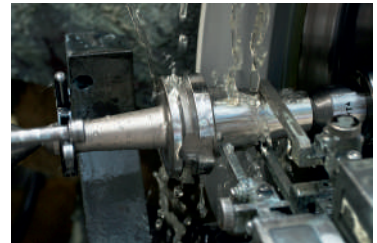

Messen und Auswuchten

Measuring and Balancing

Métrie et Équilibrage

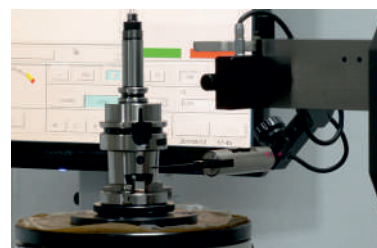
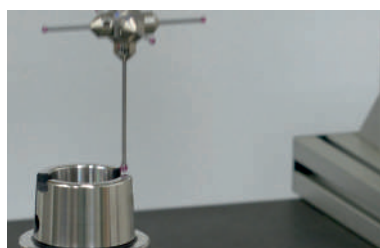
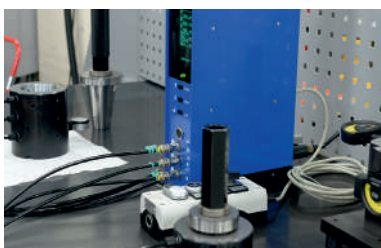
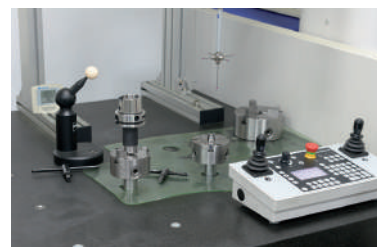
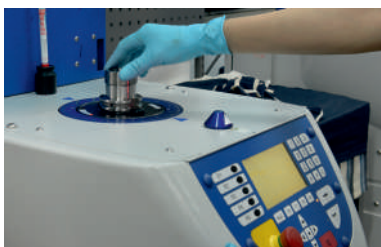



KEMMLER®

Präzision in Perfektion

KEMMLER® Präzisionswerkzeuge ist Ihr kompetenter Partner und Lieferant für qualitativ hochwertige Produkte und fertigt auf Werkzeugmaschinen der jüngsten Generation. Als Hersteller von Werkzeugaufnahmen hat sich das mehrsprachige Unternehmen aufgrund hoher Innovationsfreude und einem überdurchschnittlichen Qualitätsniveau vor Jahren am nationalen und internationalen Markt etabliert.

Der Vertrieb der Produkte erfolgt über die führenden Handelshäuser, Werkzeughersteller, namhaften Erstausrüster und den einschlägigen Fachhandel.

KEMMLER® steht für höchste Präzision in Perfektion, Zuverlässigkeit sowie Qualität und kann damit seine Produkte in besonders anspruchsvollen Branchen zum Einsatz bringen: Luft- und Raumfahrt, Maschinenbau, Medizintechnik und Automobilindustrie.

KEMMLER®

Precision in perfection

KEMMLER® Präzisionswerkzeuge is your professional partner and supplier for high quality products and manufactures with machine tools of the latest generation.

As a manufacturer of tool holders, the multilingual business has established on the national and international market since years due to high innovation and an above-average quality level.

The products distribution takes place via leading retail companies, tool manufacturer, original equipment manufacturers and the specialist shops.

KEMMLER® stands for high-precision in perfection, reliability as well as quality and can thus bring its products to ambitious industries: aerospace, engineering, medical technology and the automotive industry.

KEMMLER®

Précision en perfection

KEMMLER® Präzisionswerkzeuge est votre partenaire et fournisseur compétent pour des produits de haute qualité fabriqués sur machines innovatrices.

En tant que producteur de porte-outils notre entreprise plurilingue s'est établie sur le marché national et international grâce à innovations permanentes et une qualité de haut niveau.

La distribution des produits s'effectue par maisons de commerce, fournisseurs d'outils, OEM connus et le commerce spécialisé.

KEMMLER® garantit haute precision , fiabilité et qualité ce qui permet l'emploi de nos produits dans des branches exigeantes – aéronautique et astronautique, construction de machines, technologie médicale et l'industrie automobile.





First Class® ist ein eingetragenes Warenzeichen der Kemmler Präzisionswerkzeuge GmbH. Ein Gütesiegel das Präzision, Qualität, Zuverlässigkeit und hervorragenden Service symbolisiert.

First Class® is a licenced trade mark of Kemmler Präzisionswerkzeuge GmbH. A grade standing for precision, quality, reliability and top class service.

First Class® est une marque déposée de Kemmler Präzisionswerkzeuge GmbH. Une marque qui représente la précision, qualité, fiabilité et un service extraordinaire.

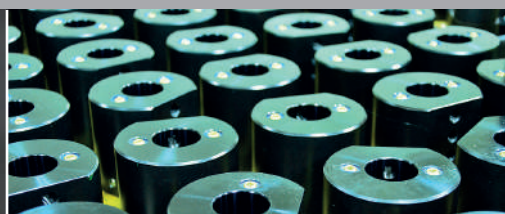



K KEMMLER®

Service in Perfektion

KEMMLER® steht nicht nur für Präzision und Qualität bei der Herstellung von Werkzeugaufnahmen, sondern wir wünschen uns vor allem, dass Sie sich wohl fühlen und bieten Ihnen einen erstklassigen Rundum-Service.



SIE BESTELLEN – WIR LIEFERN

KEMMLER® möchte seinen Kunden lange Wartezeiten auf bestellte Ware ersparen. Daher sind rund 98% der **KEMMLER®**-Produkte sofort ab Lager lieferbar. Zudem können Sie als Kunde jederzeit online die Lieferverfügbarkeit abrufen – einfach einloggen, die gewünschte Ware abrufen und bestellen.

K KEMMLER®

Service in perfection

KEMMLER® not only stands for precision and quality in the manufacture of toolholders, but our aim is to make you feel comfortable and therefore we offer you a first class all round service.



YOU ORDER – WE DELIVER

KEMMLER® minimizes delivery time for ordered goods. Therefore 98% of all **KEMMLER®**-products are available ex-stock. As a registered customer you can check the availability of the products anytime by online access – just log in, retrieve the desired goods and place the order.

K KEMMLER®

Service en perfection

KEMMLER® ne signifie pas seulement précision et qualité au niveau de nos produits. Nous tenons surtout à votre contentement et nous nous efforçons à vous offrir un service complet.



VOUS COMMANDEZ – NOUS EXPÉDIONS

KEMMLER® réduit de longs délais. 98% des produits Kemmler sont en stock. Sur notre site nos clients peuvent vérifier si l'article demandé est disponible. Il faut tout simplement se connecter sur internet et passer la commande.

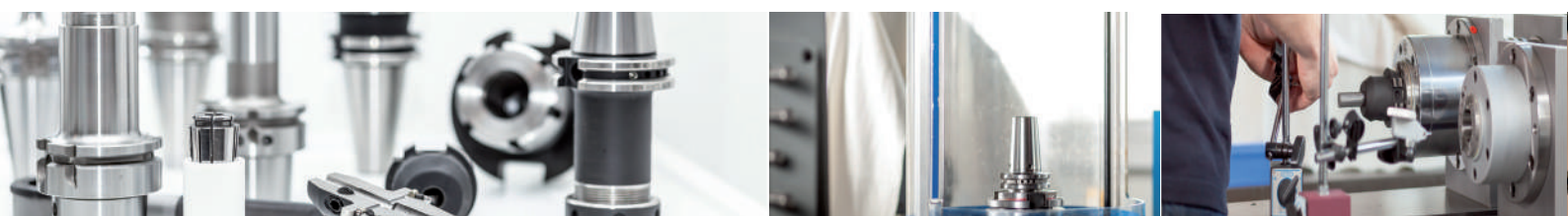



KEMMLER® WELTWEIT

Als Unternehmen mit internationaler Ausrichtung möchten wir auf die Bedürfnisse unserer Kunden weltweit eingehen: mit persönlicher und kompetenter Fachberatung, der Unterstützung unseres mehrsprachigen Teams und umfassenden, dreisprachigen Produktkatalogen sind wir für Sie da.

Darf es etwas mehr sein?

Sie benötigen spezielle Werkzeuge? Wir stellen uns jeder Herausforderung und fertigen für Sie kurzfristig Sonderwerkzeuge nach Wunsch und liefern innerhalb weniger Wochen.



KEMMLER® WORLDWIDE

As a company with international focus, we want to commit to the needs of our worldwide customers: with personal and competent technical advice, the support of our multi-lingual team and comprehensive, trilingual product catalogues, we are ready to attend you.

Any additional requirements?

You need special tools? We accept every challenge and finish special tools according to your wishes and deliver within few weeks.



KEMMLER® AUTOUR DU MONDE

Comme entreprise à orientation internationale notre objectif est de répondre aux besoins de nos clients dans le monde entier: par une consultation individuelle de notre personnel plurilingue et qualifié et des catalogues détaillés trilingues.

Vous avez un besoin en plus?

Il vous faut des outils spéciaux? Nous acceptons le défi et fabriquons des porte-outils spéciaux sur demande à court terme.



SCHNELLER SERVICE

Wir garantieren Ihnen eine zügige und reibungslose Bestellabwicklung. Wir bearbeiten Ihre Kundenanfragen direkt und verschicken die Ware noch am selben Tag an Sie oder ihren Kunden. Neben einer schnellen Abwicklung erhalten Sie zusätzlich eine Versandbestätigung per E-Mail und können Ihre Bestellung nachverfolgen. Bei Bestellungen aus dem Ausland übernimmt KEMMLER® die Zollformalitäten.



RAPID SERVICE

We guarantee a fast and smooth order processing. We execute your customer inquiries directly and send the goods the same day to you or your customer. In addition to a quick execution you will receive a shipping confirmation by e-mail and you will be able to track your order online. For orders from foreign countries KEMMLER® procures the incurring customs formalities.



SERVICE RAPIDE

Nous garantissons un déroulement vite et sans difficulté. Nous traitons les commandes de vos clients et expédions la marchandise le même jour directement à votre clientèle bien sûr en emballage neutre. La preuve d'expédition vous parvient par mail et vous permet de suivre le transport. KEMMLER® s'occupe des formalités douanières si nécessaire.





K KEMMLER®
Qualität in Perfektion

100% GEPRÜFTE KEMMLER® QUALITÄT

Wer hohe Ansprüche hat, kann sich keine Kompromisse erlauben.

Deshalb fertigt Kemmler leistungsstarke Werkzeuge für optimale Zerspanungsprozesse.

- Sämtliche Aufnahmen werden aus geschmiedetem Stahl gefertigt
- Spezifisch, verzugsarm gehärtet
- Oberflächenhärte HRC 60 ± 2
- Härtetiefe 0,8 mm ± 0,2 mm
- Brüniert und präzisionsgeschliffen
- Kegelwinkeltoleranz < AT 3 nach DIN 7187 und DIN 2080
- Max. Rundlauffehler kleiner als 0,003 mm
- Oberflächenrauigkeit Rz kleiner als 0,5 µ
- Zugfestigkeit im Kern von min. 800 N/mm²
- Standardmäßig dynamisch gewuchtet auf G 6,3 / 15.000 U/min

- Wir liefern Qualität auf höchstem Niveau
- 100 % Qualitätssicherung
- Unschlagbares Preis-Leistungs-Verhältnis
- Katalogwerkzeuge ab Lager lieferbar
- Sonderwerkzeuge kurzfristig innerhalb weniger Wochen
- Qualitätsmanagement nach DIN EN ISO 9001
- Umweltmanagement nach DIN EN ISO 14001
- Qualitätsmanagement nach IATF 16949



100% CERTIFICATED KEMMLER® QUALITY
*Who has high claims cannot afford to make compromises.
Therefore Kemmler manufactures powerful tools for ideal machining processes.*

- All holders are made of forged steel
- Specific, low warpage hardened
- Surface hardened HRC 60 ± 2
- Hardening depth 0,8 mm ± 0,2 mm
- Black-finished and precisionground
- Taper angle tolerance < AT 3 according to DIN 7187 and DIN 2080
- Max. runout less than 0,003 mm
- Surface roughness Rz less than 0,5 μ
- Tensile strength in the core of min. 800 N/mm²
- Dynamically balanced by default G 6,3 / 15.000 U/min

- We deliver quality at the highest level
- 100 % quality control
- Unbeatable price-performance ratio
- Catalogue tools available ex-stock
- Special tools shortly available within a few weeks
- Quality management according to DIN EN ISO 9001
- Environment management according to DIN EN ISO 14001
- Quality management according to IATF 16949

QUALITÉ KEMMLER® ÉPROUVÉ A 100 %

Ce qui a des exigences élevés ne peut pas accepter des compromis. Kemmler produit des porte-outils performants pour usinage optimal.

- Tous les porte-outils sont fabriqués d'acier forge
- Trempé spécifiquement, déformation minimale
- Rigueur superficielle HRC 60± 2
- Profondeur trempée 0,8 mm ± 2 mm
- Bruni et rectifié précisément
- Tolerance angle du cône < AT 3 selon DIN 7187 et DIN 2080
- Erreur de concentricité max. < 0,003 mm
- Rugosité de la surface Rz <0,5 μ
- Résistance à la traction au moins 800 N/mm²
- Equilibrage dynamique standard G 6,3 / 15.000 t/min

- Nous fournissons une qualité de haut niveau
- 100 % d'assurance qualité
- Rapport prix-performance imbattable
- Porte-outils „standard“ en stock
- Porte-outils spéciaux à court terme
- Contrôle de qualité selon DIN EN ISO 9001
- Management environnemental DIN EN ISO 14001
- Contrôle de qualité selon IATF 16949



IATF 16949
Qualitätsmanagementsystem für die Automobilindustrie

Die Zertifizierung nach IATF 16949 ergänzt unser bereits seit vielen Jahren eingerichtetes Qualitätssicherungssystem nach DIN/ISO 9001/9002. Wir hatten uns zur Zertifizierung entschieden, da für ein Produktionsunternehmen unserer Branche eine Qualitätssicherung nahezu unabdingbare Voraussetzung ist. Hierzu war die IATF 16949 der richtige Maßstab, da sich diese Qualitätssicherungsnorm nicht wie bei den bisherigen Normen auf den Herstellungs- und Prüfungsaspekt der Produkte beschränkt. Sie ist vielmehr ein gesamtunternehmerischer Ansatz, der u.a. das Managementsystem, die Technologie, die Wettbewerbsfähigkeit sowie den Arbeits- und Umweltschutz des Unternehmens einer sehr kritischen Überprüfung und Bewertung unterzieht.

Mit dem Erreichen der IATF 16949 Zertifizierung sehen wir eine Steigerung unserer Leistungsfähigkeit und Verantwortung, die Kundenforderungen qualitätsgerecht und gezielt umzusetzen. Wir überprüfen unsere Kundenorientierung nicht nur, indem wir das Ohr am Kunden haben, sondern auch durch Bewertung der Kundenzufriedenheit und der internen Kunden-Lieferanten-Beziehungen in unserem Unternehmen.

Benchmarking und die Optimierung unserer Prozesse sind Schlüsselfunktionen für weitere Meilensteine unseres Erfolges.



IATF 16949
Quality management system for the automobile industry

The certificate according to IATF 16949 supplements our quality assurance system as described in DIN/ISO 9001/9002, which we established many years ago. Our decision to obtain quality certification is based on the fact that for a producing company independent quality assurance is almost a predetermined prerequisite. In this regard, the IATF 16949 was considered to be the ideal level of measure because the quality assurance standard is not, as in the case of other previously used standards, restricted to manufacturing and examination aspects of our products. In essence, it forms a complete industrial basis including the management system, technology, competitiveness as well as labour and environmental protection, thus providing a critical examination and evaluation.

Our successful acquisition of the certification according to IATF 16949 increases our productivity and potential to implement customer requirements in a qualitative and effective fashion. We review our customer orientation not only by keeping close touch with their needs but also by evaluating customer satisfaction and the relationship between customers and suppliers within our company. Setting benchmarks and optimising internal processes are key indicators for further milestones of our success.



IATF 16949
Système de gestion de qualité pour l'industrie automobile

Ce certificat d'après IATF 16949 complète notre système d'assurance de qualité d'après DIN/ISO 9001/9002 qui a été implanté avant plusieurs ans. Nous avons décidé d'être certifié, parce que pour une entreprise produisant une certification de qualité est presque une supposition inaliénable dans notre branche. L' IATF 16949 a été le bon critère, parce que ce standard d'assurance de qualité ne se limite pas à l'aspect de la production et vérification de nos produits, comme c'était le cas chez des standards précédents. Elle est plutôt un fondement industriel complet, qui inclut le système de gestion, technologie, compétitivité ainsi que protection de l'emploi et de l'environnement, donc fournissant une vérification et évaluation très solide.

Notre acquisition du certificat d'après IATF 16949 élève notre productivité et potentiel de réaliser des demandes de nos clients dans une manière qualitative et effective. Nous vérifions l'orientation de nos clients ne pas seulement par nous aligner sur leurs demandes, mais aussi par évaluer leur satisfaction et la relation entre clients et fournisseurs dans notre société. Benchmarking et l'optimisation de nos procès sont les indicateurs décisifs pour des jalons supplémentaires de notre succès.



Technische Datenblätter, STEP/STL Modelle für die Simulation der NC-Programme und DXF-Zeichnungen zur Erstellung des Einrichteblattes stehen Online zur Verfügung.

Technical data sheets, STEP/STL models for the simulation of NC programs and DXF drawings to create the tooling sheet are online available.

Fiches techniques, STEP/STL modèles techniques pour la simulation de programmes CN et dessins DXF pour créer la feuille d'installation sont disponible online.

Sie können unsere Kataloge entweder direkt im Browser betrachten oder sie auf Ihren PC, Smartphone oder Tablet herunterladen (PDF-Reader notwendig).

You can view our catalogues either directly in the browser or download to your PC, smartphone or tablet (PDF reader required).

Vous pouvez consulter nos catalogues directement dans le navigateur ou télécharger sur votre PC, smartphone ou tablet (lecteur PDF requis).

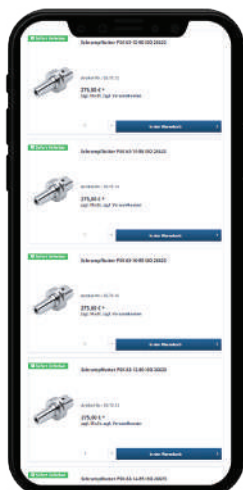

Auf unserer Internetseite können Sie die Lagerverfügbarkeit prüfen - auch auf Mobilgeräten.

On our website you can check the stock availability - also on mobile devices.

Vous pouvez également vérifier la disponibilité de nos produits sur le site Internet - ainsi que sur vos appareils

WERKZEUGAUFNAHMEN
ISO 7388-1
(ehemals DIN 69871)

TOOLHOLDERS
ISO 7388-1
(formerly DIN 69871)

PORTE-OUTILS
ISO 7388-1
(l'ancien DIN 69871)

ISO 7388-1

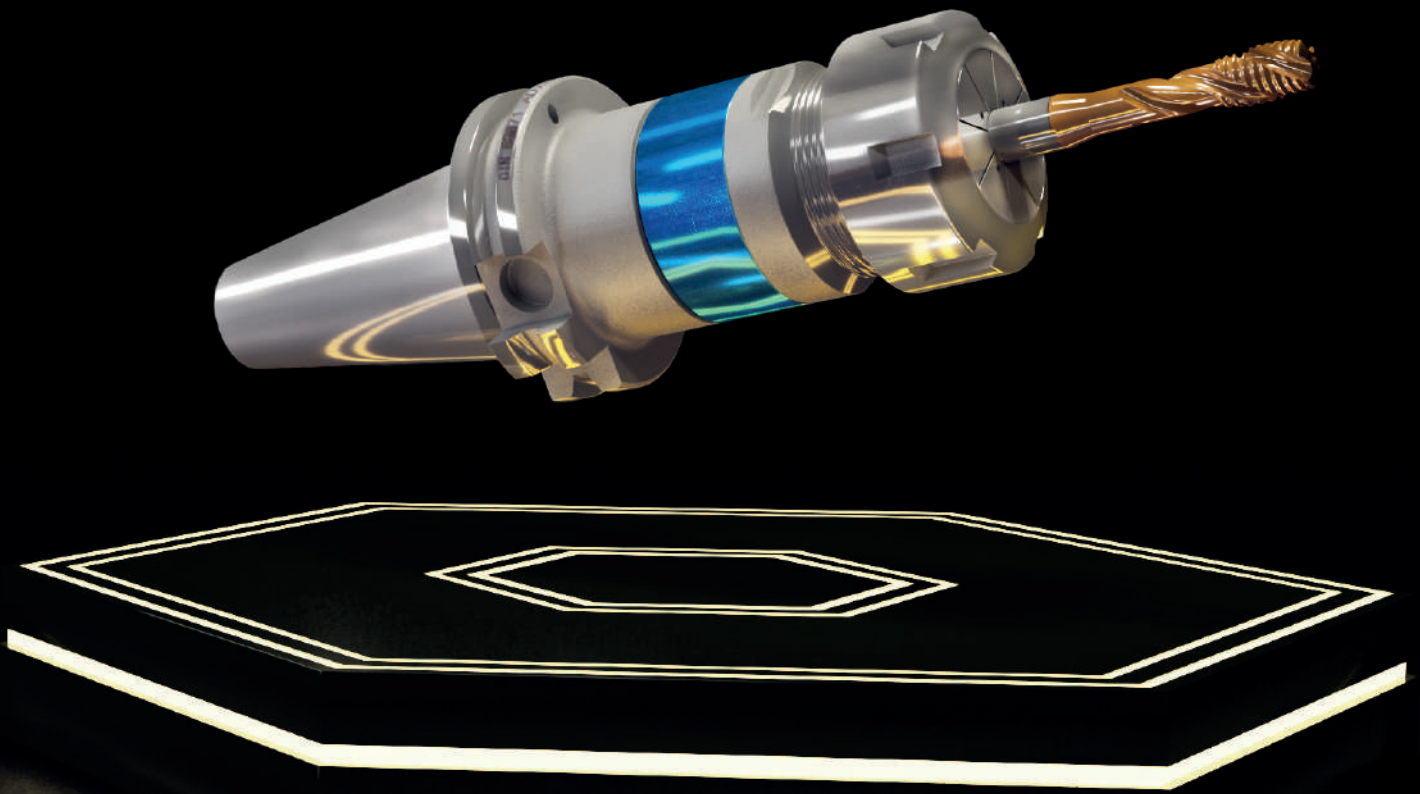

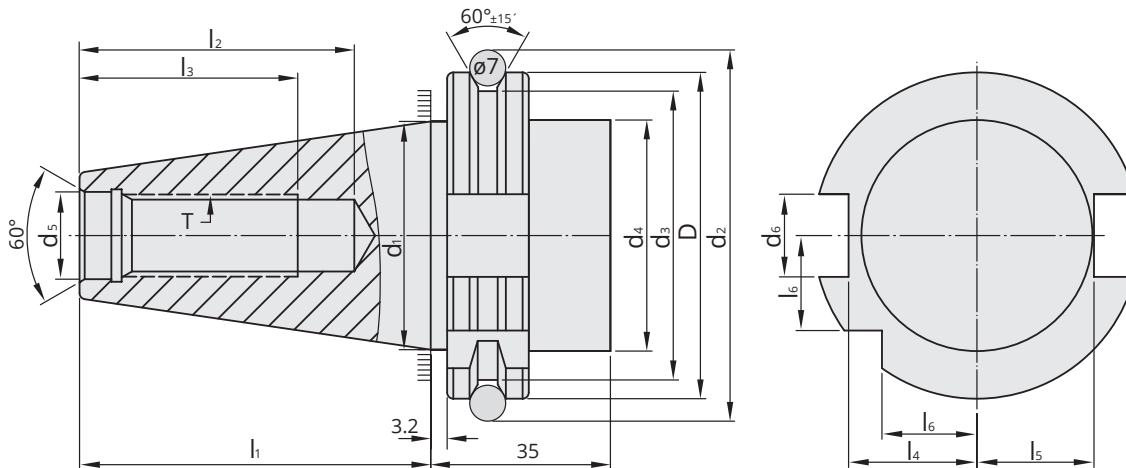

SK	D	d ₁	d ₂	d ₃	d ₄	d ₅	d ₆	d ₉	l ₁	l ₂	l ₃	l ₄	l ₅	l ₆	e ₁	e ₂	T
	$\begin{matrix} 0 \\ -0,1 \end{matrix}$		$\pm 0,05$	$\begin{matrix} 0 \\ -0,5 \end{matrix}$	max	H7	H12		$\begin{matrix} 0 \\ -0,3 \end{matrix}$	min	min	$\begin{matrix} 0 \\ -0,4 \end{matrix}$	$\begin{matrix} 0 \\ -0,4 \end{matrix}$	$\begin{matrix} 0 \\ -0,3 \end{matrix}$	$\pm 0,1$	max	
30	50,00	31,75	59,30	44,30	45	13	16,1	4	47,8	33,5	24	19	16,4	15	21	5	M12
40	63,55	44,45	72,30	56,25	50	17	16,1	4	68,4	42,5	32	25	22,8	18,5	27	5	M16
50	97,50	69,85	107,25	91,25	80	25	25,7	6	101,75	61,5	47	37,7	35,5	30	42	7	M24

Vorgewuchtet G 6,3 15.000 min⁻¹
Pre-balanced
 Pré-équilibré

G 2,5 Feinwuchten gegen Aufpreis
G 2.5 Fine balancing at extra charge
 G 2,5 Équilibrage de précision moyennant un supplément

Mit innerer Kühlmittelzufuhr über den Bund - Form AD/AF (ehemals AD/B)

With internal coolant through the collar - form AD/AF (formerly AD/B)

Avec arrosage interne par la collerette - forme AD/AF (anciennement AD/B)

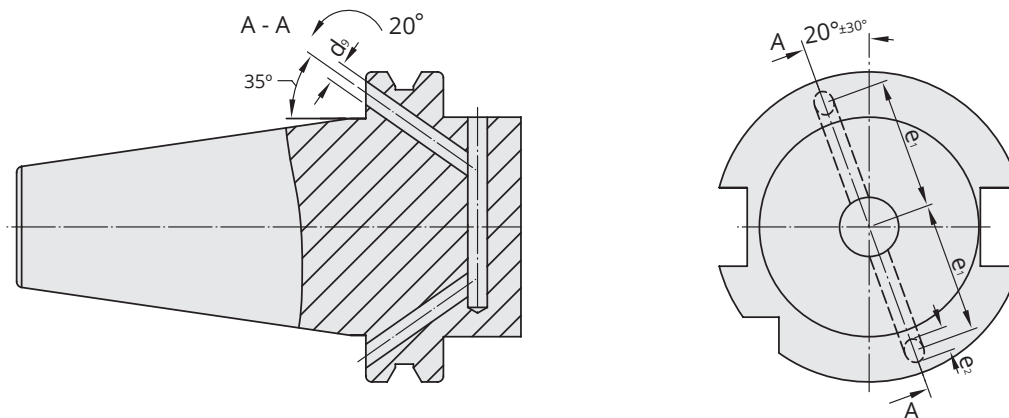

Werkstoff: Legierter Einsatzstahl mit einer Zugfestigkeit im Kern von min. 950 N / mm². Einsatzgehärtet HRC 60 ± 2 (HV 700 ± 50), Härtetiefe 0,8 mm ± 0,2 mm, brüniert und präzisionsgeschliffen.

Form AD/AF: Lieferung in Ausführung AD, Form AF (B) mit lösbaren Gewindestiften verschlossen.

Genauigkeit: Kegelwinkel - Toleranzqualität < AT 3 nach DIN 7187 und DIN 2080.

Material: Alloyed case-hardened steel, tensile core strength of min. 950 N / mm². Case hardened HRC 60 ± 2 (HV 700 ± 50), hardening depth 0.8 mm ± 0.2 mm, black-finished and precisely grinded.

Form AD/AF: Delivery in form AD, type (B) closed with releasable headless screws.

Accuracy: Quality of taper < AT 3 according to DIN 7187 and DIN 2080.

Matière: Acier de cémentation allié. Résistance à la traction dans le noyau d'au moins 950 N / mm². Cémenté et trempé HRC 60 ± 2 (HV 700 ± 50), profondeur de trempé 0,8 mm ± 0,2 mm, brunie et rectifiée avec précision.

Forme AD/AF: Livraison en forme AD, forme AF (B) fermée avec de vis sans tête amovibles.

Précision: Angle de cône - qualité de tolérance < AT 3 selon DIN 7187 et DIN 2080



1.05	1.06	1.09	1.11
1.12	1.13	1.14	1.15
1.16	1.21	1.26	1.27
1.28	1.29	1.30	1.31
1.33	1.35	1.36	1.37
1.39	1.40	1.41	1.42
1.43	1.44	1.47	1.49
1.50	1.55	1.56	

1



Verwendung:
Zur Aufnahme von Werkzeugen mit Zylinderschaft in Spannzangen.

Application:
For mounting straight-shank tools in collets.

Utilisation:
Pour la fixation d'outils à queue cylindrique dans les pinces de serrage.

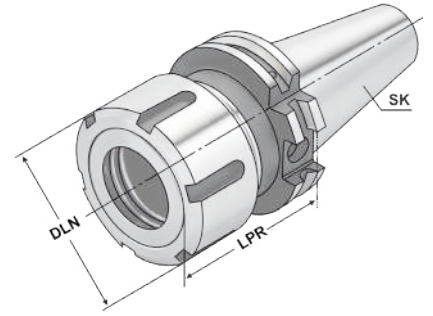

Bestell-Nr. Order no. Référence	SK	DCONWS Spannbereich Capacity Capacité	Typ	LPR	DLN	THID
302.01.16 *	SK 30	2 - 16	415E OZ 16	60	43	M16 x 2,0
302.01.25 *	SK 30	2 - 25	462E OZ 25	80	60	M16 x 2,0
403.01.16	SK 40	2 - 16	415E OZ 16	70	43	M16 x 2,0
403.01.25	SK 40	2 - 25	462E OZ 25	70	60	M16 x 2,0
403.01.32	SK 40	3 - 32	467E OZ 32	90	72	M16 x 2,0
403.01.16.1	SK 40	2 - 16	415E OZ 16	100	43	M16 x 2,0
403.01.25.1	SK 40	2 - 25	462E OZ 25	100	60	M16 x 2,0
503.01.25	SK 50	2 - 25	462E OZ 25	70	60	M16 x 2,0
503.01.32	SK 50	3 - 32	467E OZ 32	80	72	M16 x 2,0
503.01.32.1	SK 50	3 - 32	467E OZ 32	100	72	M16 x 2,0

* DIN 69871 Form AD
* DIN 69871 form AD
* DIN 69871 forme AD

Lieferumfang: Mit kugellagerter Spannmutter
Delivery: With ball bearing clamping nut
Livraison: Avec écrou de serrage monté sur roulement à billes

Gewuchtete Ausführung

Balanced type
Version équilibrée



Bestell-Nr. Order no. Référence	Abmessung Size Dimension
---------------------------------------	--------------------------------

Wuchten auf G 2,5 von vorgewuchteten Kemmler-Werkzeugen

Balancing at G 2.5 of pre-balanced Kemmler-tools
Équilibrage G 2,5 d'outils Kemmler pré-équilibrés

W25 **Ohne Wuchtprotokoll**
Without balancing report
Sans protocole d'équilibrage

W25.2 **Mit Wuchtprotokoll**
With balancing report
Avec protocole d'équilibrage

Wuchten von nicht vorgewuchteten Werkzeugen
Balancing of unbalanced tools
Équilibrage d'outils non-équilibrés

W25.1 **Ohne Wuchtprotokoll**
Without balancing report
Sans protocole d'équilibrage



Collet chucks for collets ISO 15488 (DIN 6499) ER-system

[DIN 69871]

Mandrin de serrage pour pinces de serrage ISO 15488 (DIN 6499) système ER

**Verwendung:**

Zur Aufnahme von Werkzeugen mit Zylinderschaft in Spannzangen.

Application:

For mounting straight-shank tools in collets.

Utilisation:

Pour la fixation d'outils à queue cylindrique dans les pinces de serrage.

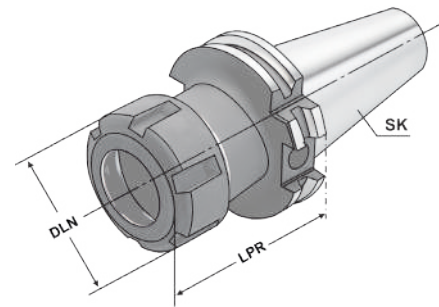

1



Bestell-Nr. Order no. Référence	SK	DCONWS Spannbereich Capacity Capacité	Typ	LPR	DLN	THID
302.02.10	SK 30	1 - 10	426E ER 16	70	32	M10 x 1,5
302.02.13	SK 30	2 - 13	428E ER 20	70	35	M12 x 1,75
302.02.16	SK 30	2 - 16	430E ER 25	70	42	M16 x 2,0
302.02.20	SK 30	2 - 20	470E ER 32	70	50	M16 x 2,0
302.02.26	SK 30	3 - 26	472E ER 40	70	63	M16 x 2,0
302.02.10.1	SK 30	1 - 10	426E ER 16	100	32	M10 x 1,5
302.02.13.1	SK 30	2 - 13	428E ER 20	100	35	M12 x 1,75
302.02.16.1	SK 30	2 - 16	430E ER 25	100	42	M16 x 2,0
302.02.20.1	SK 30	2 - 20	470E ER 32	100	50	M16 x 2,0
402.02.10	SK 40	1 - 10	426E ER 16	63	32	M10 x 1,5
402.02.13	SK 40	2 - 13	428E ER 20	70	35	M12 x 1,75
402.02.16	SK 40	2 - 16	430E ER 25	60	42	M16 x 2,0
402.02.20	SK 40	2 - 20	470E ER 32	70	50	M16 x 2,0
402.02.26	SK 40	3 - 26	472E ER 40	80	63	M16 x 2,0
402.02.10.1	SK 40	1 - 10	426E ER 16	100	32	M10 x 1,5
402.02.13.1	SK 40	2 - 13	428E ER 20	100	35	M12 x 1,75
402.02.16.1	SK 40	2 - 16	430E ER 25	100	42	M16 x 2,0
402.02.20.1	SK 40	2 - 20	470E ER 32	100	50	M16 x 2,0
402.02.26.1	SK 40	3 - 26	472E ER 40	100	63	M16 x 2,0

Lieferumfang: Mit gewuchteter Spannmutter
Delivery: With balanced clamping nut
Livraison: Avec écrou de serrage équilibré



1



Verwendung:
Zur Aufnahme von Werkzeugen mit Zylinderschaft in Spannzangen.

Application:
For mounting straight-shank tools in collets.

Utilisation:
Pour la fixation d'outils à queue cylindrique dans les pinces de serrage.

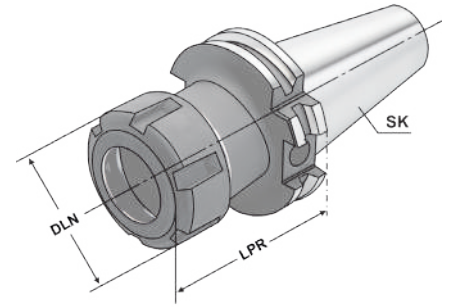

ISO 7388-1

Form AD/AF (AD/B)

≤ 3µm

G2.5 25.000 min⁻¹

RFID Chip

ISO 15488

i
13.04

Bestell-Nr. Order no. Référence	SK	DCONWS Spannbereich Capacity Capacité	Typ	LPR	DLN	THID
403.02.10	SK 40	1 - 10	426E ER 16	63	32	M10 x 1,5
403.02.13	SK 40	2 - 13	428E ER 20	70	35	M12 x 1,75
403.02.16	SK 40	2 - 16	430E ER 25	60	42	M16 x 2,0
403.02.20	SK 40	2 - 20	470E ER 32	70	50	M16 x 2,0
403.02.26	SK 40	3 - 26	472E ER 40	80	63	M16 x 2,0
403.02.10.1	SK 40	1 - 10	426E ER 16	100	32	M10 x 1,5
403.02.13.1	SK 40	2 - 13	428E ER 20	100	35	M12 x 1,75
403.02.16.1	SK 40	2 - 16	430E ER 25	100	42	M16 x 2,0
403.02.20.1	SK 40	2 - 20	470E ER 32	100	50	M16 x 2,0
403.02.26.1	SK 40	3 - 26	472E ER 40	100	63	M16 x 2,0
403.02.10.130	SK 40	1 - 10	426E ER 16	130	32	M10 x 1,5
403.02.13.130	SK 40	2 - 13	428E ER 20	130	35	M12 x 1,75
403.02.16.130	SK 40	2 - 16	430E ER 25	130	42	M16 x 2,0
403.02.20.130	SK 40	2 - 20	470E ER 32	130	50	M16 x 2,0
403.02.26.130	SK 40	3 - 26	472E ER 40	130	63	M16 x 2,0
403.02.10.2	SK 40	1 - 10	426E ER 16	160	32	M10 x 1,5
403.02.13.2	SK 40	2 - 13	428E ER 20	160	35	M12 x 1,75
403.02.16.2	SK 40	2 - 16	430E ER 25	160	42	M16 x 2,0
403.02.20.2	SK 40	2 - 20	470E ER 32	160	50	M16 x 2,0
403.02.26.2	SK 40	3 - 26	472E ER 40	160	63	M16 x 2,0
403.02.10.3	SK 40	1 - 10	426E ER 16	200	32	M10 x 1,5
403.02.13.3	SK 40	2 - 13	428E ER 20	200	35	M12 x 1,75
403.02.16.3	SK 40	2 - 16	430E ER 25	200	42	M16 x 2,0
403.02.20.3	SK 40	2 - 20	470E ER 32	200	50	M16 x 2,0
403.02.26.3	SK 40	3 - 26	472E ER 40	200	63	M16 x 2,0

Lieferumfang: Mit gewichteter Spannmutter
Delivery: With balanced clamping nut
Livraison: Avec écrou de serrage équilibré



Collet chucks for collets ISO 15488 (DIN 6499) ER-system

[DIN 69871]

Mandrin de serrage pour pinces de serrage ISO 15488 (DIN 6499) système ER

**Verwendung:**

Zur Aufnahme von Werkzeugen mit Zylinderschaft in Spannzangen.

Application:

For mounting straight-shank tools in collets.

Utilisation:

Pour la fixation d'outils à queue cylindrique dans les pinces de serrage.

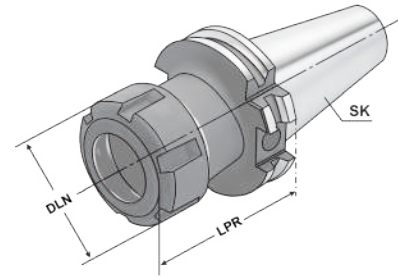

1



Bestell-Nr. Order no. Référence	SK	DCONWS Spannbereich Capacity Capacité	Typ	LPR	DLN	THID
503.02.10	SK 50	1 - 10	426E ER 16	70	32	M10 x 1,5
503.02.13	SK 50	2 - 13	428E ER 20	70	35	M12 x 1,75
503.02.16	SK 50	2 - 16	430E ER 25	60	42	M16 x 2,0
503.02.20	SK 50	2 - 20	470E ER 32	70	50	M16 x 2,0
503.02.26	SK 50	3 - 26	472E ER 40	80	63	M16 x 2,0
503.02.10.1	SK 50	1 - 10	426E ER 16	100	32	M10 x 1,5
503.02.13.1	SK 50	2 - 13	428E ER 20	100	35	M12 x 1,75
503.02.16.1	SK 50	2 - 16	430E ER 25	100	42	M16 x 2,0
503.02.20.1	SK 50	2 - 20	470E ER 32	100	50	M16 x 2,0
503.02.26.1	SK 50	3 - 26	472E ER 40	100	63	M16 x 2,0
503.02.10.130	SK 50	1 - 10	426E ER 16	130	32	M10 x 1,5
503.02.13.130	SK 50	2 - 13	428E ER 20	130	35	M12 x 1,75
503.02.16.130	SK 50	2 - 16	430E ER 25	130	42	M16 x 2,0
503.02.20.130	SK 50	2 - 20	470E ER 32	130	50	M16 x 2,0
503.02.26.130	SK 50	3 - 26	472E ER 40	130	63	M16 x 2,0
503.02.10.2	SK 50	1 - 10	426E ER 16	160	32	M10 x 1,5
503.02.13.2	SK 50	2 - 13	428E ER 20	160	35	M12 x 1,75
503.02.16.2	SK 50	2 - 16	430E ER 25	160	42	M16 x 2,0
503.02.20.2	SK 50	2 - 20	470E ER 32	160	50	M16 x 2,0
503.02.26.2	SK 50	3 - 26	472E ER 40	160	63	M16 x 2,0
503.02.10.3	SK 50	1 - 10	426E ER 16	200	32	M10 x 1,5
503.02.13.3	SK 50	2 - 13	428E ER 20	200	35	M12 x 1,75
503.02.16.3	SK 50	2 - 16	430E ER 25	200	42	M16 x 2,0
503.02.20.3	SK 50	2 - 20	470E ER 32	200	50	M16 x 2,0
503.02.26.3	SK 50	3 - 26	472E ER 40	200	63	M16 x 2,0

Lieferumfang: Mit gewuchteter Spannmutter
Delivery: With balanced clamping nut
Livraison: Avec écrou de serrage équilibré



1



Verwendung:
Zur Aufnahme von Werkzeugen mit Zylinderschaft in Spannzangen.
Für Anwendungen im HSC-Bereich und für hochpräzise Bearbeitungsergebnisse.

Application:
For mounting straight-shank tools in collets.
To use for high speed cutting and high precision milling.

Utilisation:
Pour la fixation d'outils à queue cylindrique dans les pinces de serrage. Pour l'UGV (Usinage à Grande Vitesse) et pour des résultats d'usinage de haute précision.

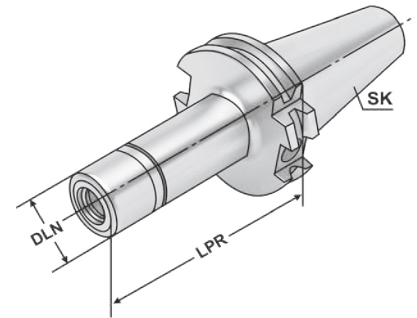

ISO 7388-1

Form AD/AF (AD/B)

≤ 3µm

G2.5 30.000 min⁻¹

RFID Chip

KPS

i
13.04

Bestell-Nr. Order no. Référence	SK	DCONWS Spannbereich Capacity Capacité	Typ	LPR	DLN	THID
302.03.10	SK 30	1 - 10	490EK KPS 10	60	27,5	M12 x 1,75
302.03.16	SK 30	4 - 16	496EK KPS 16	60	40	M18 x 1,50
302.03.10.1	SK 30	1 - 10	490EK KPS 10	90	27,5	M12 x 1,75
302.03.16.1	SK 30	4 - 16	496EK KPS 16	90	40	M18 x 1,50
402.03.10	SK 40	1 - 10	490EK KPS 10	60	27,5	M12 x 1,75
402.03.16	SK 40	4 - 16	496EK KPS 16	60	40	M18 x 1,50
402.03.10.1	SK 40	1 - 10	490EK KPS 10	90	27,5	M12 x 1,75
402.03.16.1	SK 40	4 - 16	496EK KPS 16	90	40	M18 x 1,50
402.03.10.2	SK 40	1 - 10	490EK KPS 10	120	27,5	M12 x 1,75
402.03.16.2	SK 40	4 - 16	496EK KPS 16	120	40	M18 x 1,50
402.03.10.3	SK 40	1 - 10	490EK KPS 10	160	27,5	M12 x 1,75
402.03.16.3	SK 40	4 - 16	496EK KPS 16	160	40	M18 x 1,50

Lieferumfang: Mit gewichteter Spannmutter
Delivery: With balanced clamping nut
Livraison: Avec écrou de serrage équilibré



**Verwendung:**

Zur Aufnahme von Werkzeugen mit Zylinderschaft in Spannzangen.
Für Anwendungen im HSC-Bereich und für hochpräzise Bearbeitungsergebnisse.

Application:

For mounting straight-shank tools in collets.
To use for high speed cutting and high precision milling.

Utilisation:

Pour la fixation d'outils à queue cylindrique dans les pinces de serrage. Pour l'UGV (Usinage à Grande Vitesse) et pour des résultats d'usinage de haute précision.

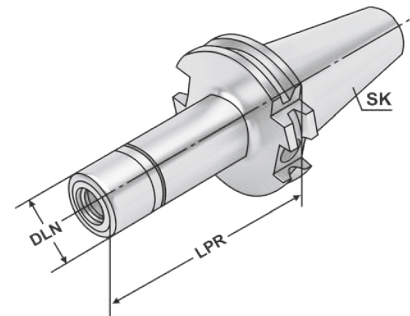

Bestell-Nr. Order no. Référence	SK	DCONWS Spannbereich Capacity Capacité	Typ	LPR	DLN	THID
502.03.10	SK 50	1 - 10	490EK KPS 10	105	27,5	M12 x 1,75
502.03.16	SK 50	4 - 16	496EK KPS 16	105	40	M18 x 1,50
502.03.10.1	SK 50	1 - 10	490EK KPS 10	135	27,5	M12 x 1,75
502.03.16.1	SK 50	4 - 16	496EK KPS 16	135	40	M18 x 1,50
502.03.10.2	SK 50	1 - 10	490EK KPS 10	165	27,5	M12 x 1,75
502.03.16.2	SK 50	4 - 16	496EK KPS 16	165	40	M18 x 1,50

Lieferumfang: Mit gewuchteter Spannmutter
Delivery: With balanced clamping nut
Livraison: Avec écrou de serrage équilibré



1

Collet chucks DIN 6391 for collets ISO 10897 (DIN 6388) OZ-system – without drive slots
 Mandrin de serrage DIN 6391 pour pinces ISO 10897 système OZ – sans rainures d'entraînement



Verwendung:
 Zur Aufnahme von Werkzeugen zur Holzbearbeitung mit Zylinderschaft in Spannzangen.

Application:
 For mounting straight-shank tools for woodworking in collets.

Utilisation:
 Pour la fixation d'outils pour le travail du bois avec à queue cylindrique dans les pinces de serrage.

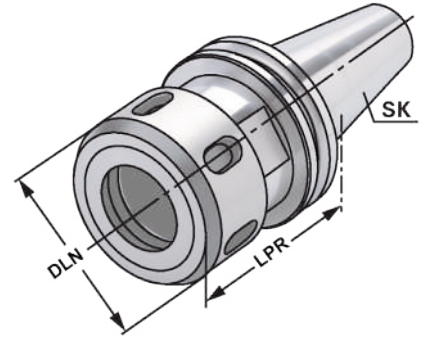

ISO 7388-1	Form AD	≤ 3µm	G2.5 25.000 min ¹	ISO 10897	13.04
------------	---------	-------	------------------------------	-----------	-------

Bestell-Nr. Order no. Référence	SK	DCONWS Spannbereich Capacity Capacité	Typ	LPR	DLN	THID
302.61.25	SK 30	2 – 25	462E OZ 25	71	60	M16 x 2,0
402.61.25	SK 40	2 – 25	462E OZ 25	63	60	M16 x 2,0

Lieferumfang: Mit kugelgelagerter Spannmutter
Delivery: With ball bearing clamping nut
Livraison: Avec écrou de serrage monté sur roulement à billes



Collet chucks for collets ISO 15488 (DIN 6499) ER-system – without drive slots

Mandrin de serrage pour pinces ISO 15488 (DIN 6499) système ER – sans rainures d'entraînement

**Verwendung:**

Zur Aufnahme von Werkzeugen zur Holzbearbeitung mit Zylinderschaft in Spannzangen.

Application:

For mounting straight-shank tools for woodworking in collets.

Utilisation:

Pour la fixation d'outils pour le travail du bois avec à queue cylindrique dans les pinces de serrage.

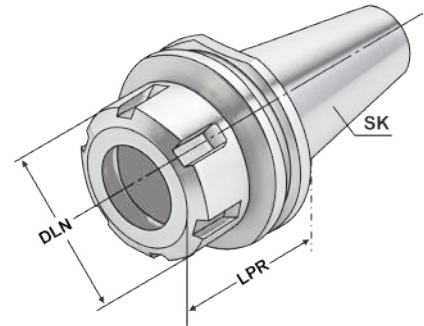

1

ISO
7388-1Form
ADISO
15488

Bestell-Nr. Order no. Référence	SK	DCONWS Spannbereich Capacity Capacité	Typ	LPR	DLN	THID
302.62.16	SK 30	2 - 16	430E ER 25	50	42	M16 x 2,0
302.62.20	SK 30	2 - 20	470E ER 32	50	50	M16 x 2,0
302.62.20.1	SK 30	2 - 20	470E ER 32	57	50	M16 x 2,0
302.62.20.2	SK 30	2 - 20	470E ER 32	63	50	M16 x 2,0
302.62.26	SK 30	3 - 26	472E ER 40	60	63	M16 x 2,0
402.62.16	SK 40	2 - 16	430E ER 25	50	42	M16 x 2,0
402.62.20	SK 40	2 - 20	470E ER 32	50	50	M16 x 2,0
402.62.26	SK 40	3 - 26	472E ER 40	63	63	M16 x 2,0

Lieferumfang: Mit gewichteter Spannmutter
Delivery: With balanced clamping nut
Livraison: Avec écrou de serrage équilibré



1



Verwendung:
 Zur Aufnahme von Werkzeugen mit Zylinderschaft in Spannzangen.
Application:
 For mounting straight-shank tools in collets.
Utilisation:
 Pour la fixation d'outils à queue cylindrique dans les pinces de serrage.

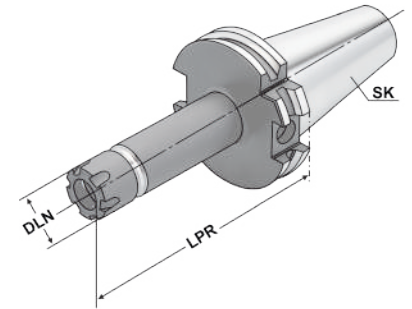

ISO 7388-1 Form AD/AF (AD/B) $\leq 3\mu\text{m}$ G2.5 25.000 min⁻¹ RFID Chip ISO 15488 13.04

Bestell-Nr. Order no. Référence	SK	DCONWS Spannbereich Capacity Capacité	Typ	LPR	DLN	THID
302.02.07*	SK 30	1 - 7	4008E ER 11	70	16	M8 x 1,25
302.02.07.1*	SK 30	1 - 7	4008E ER 11	100	16	M8 x 1,25
302.02.07.10*	SK 30	1 - 10	426E ER 16	70	22	7/16" 20 UNF
302.02.07.10.1*	SK 30	1 - 10	426E ER 16	100	22	7/16" 20 UNF
403.02.07	SK 40	1 - 7	4008E ER 11	55	16	M8 x 1,25
403.02.07.1	SK 40	1 - 7	4008E ER 11	100	16	M8 x 1,25
403.02.07.2	SK 40	1 - 7	4008E ER 11	160	16	M8 x 1,25
403.02.07.10	SK 40	1 - 10	426E ER 16	55	22	7/16" 20 UNF
403.02.07.10.1	SK 40	1 - 10	426E ER 16	100	22	7/16" 20 UNF
403.02.07.10.2	SK 40	1 - 10	426E ER 16	160	22	7/16" 20 UNF
403.02.07.13	SK 40	2 - 13	428E ER 20	70	28	9/16" 18 UNF
403.02.07.13.1	SK 40	2 - 13	428E ER 20	100	28	9/16" 18 UNF
403.02.07.13.2	SK 40	2 - 13	428E ER 20	160	28	9/16" 18 UNF
403.02.07.16	SK 40	2 - 16	430E ER 25	70	35	11/16" 16 UN
403.02.07.16.1	SK 40	2 - 16	430E ER 25	100	35	11/16" 16 UN
403.02.07.16.2	SK 40	2 - 16	430E ER 25	160	35	11/16" 16 UN
503.02.07.10.1	SK 50	1 - 10	426E ER 16	100	22	7/16" 20 UNF
503.02.07.10.2	SK 50	1 - 10	426E ER 16	160	22	7/16" 20 UNF

* Form AD
 * Form AD
 * Forme AD

Lieferumfang: Mit gewuchteter Spannmutter und Verstelle schraube
Delivery: With balanced clamping nut and adjusting screw
Livraison: Avec écrou de serrage équilibré et vis de réglage



Precision collet chuck ER for collets ISO 15488 (DIN 6499) ER-system

Mandrin à pinces de précision ER pour pinces ISO 15488 (DIN 6499) système ER



Verwendung:
Zur Aufnahme von Werkzeugen mit Zylinderschaft in 3 µm-Spannzangen.

Application:
For mounting straight-shank tools in 3 µm-collets.

Utilisation:
Pour la fixation d'outils à queue cylindrique dans les pinces de serrage de 3 µm

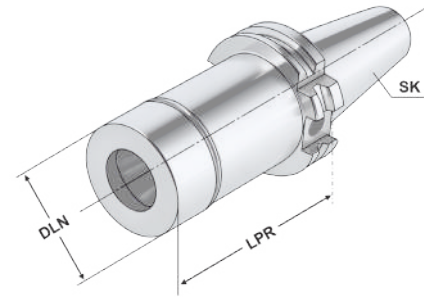

ISO 7388-1 Form AD $\leq 3\mu\text{m}$ G2.5 25.000 min⁻¹ RFID Chip ISO 15488



Bestell-Nr. Order no. Référence	SK	DCONWS Spannbereich Capacity Capacité	Typ	LPR	LB	DLN	THID
402.P2.20.070	SK 40	2 - 20	470E ER 32	70	50,1	50	M16 x 2,0
402.P2.20.100	SK 40	2 - 20	470E ER 32	100	80,1	50	M16 x 2,0
402.P2.20.125	SK 40	2 - 20	470E ER 32	125	105,1	50	M16 x 2,0
402.P2.20.150	SK 40	2 - 20	470E ER 32	150	130,1	50	M16 x 2,0
402.P2.20.200	SK 40	2 - 20	470E ER 32	200	180,1	50	M16 x 2,0
502.P2.20.070	SK 50	2 - 20	470E ER 32	70	50,1	50	M16 x 2,0
502.P2.20.100	SK 50	2 - 20	470E ER 32	100	80,1	50	M16 x 2,0
502.P2.20.125	SK 50	2 - 20	470E ER 32	125	105,1	50	M16 x 2,0
502.P2.20.150	SK 50	2 - 20	470E ER 32	150	130,1	50	M16 x 2,0
502.P2.20.200	SK 50	2 - 20	470E ER 32	200	180,1	50	M16 x 2,0

Vorteile:

Exzellente Rundlaufgenauigkeit im System (Futter + Spannzange + Spannmutter)
 Extreme Haltekräfte (erhöht die Haltekraft um mindestens 60 % im Vergleich zu Standard ER-Futter)
 Glatte Spannmutter ohne Nuten für Hochgeschwindigkeitsbearbeitung

Advantages:

Excellent concentricity in the system (chuck + collet + clamping nut)
 Extremely strong holding force (increases the holding power by at least 60% compared to standard ER chuck)
 Plain clamping nut without grooves for high speed machining

Avantages:

Excellente concentricité du système (mandrin + pince de serrage + écrou de serrage)
 La force de rétention est extrêmement forte (augmente la force de rétention d'au moins 60 % par rapport aux mandrins ER standard)
 Ecrou de serrage lisse sans rainures pour l'usinage à grande vitesse

Hinweis:

Nur das Nennmaß DCONWS kann gespannt werden.

Note:

Only nominal size DCONWS can be clamped.

Remarque:

Seulement la dimension nominale DCONWS peut être serrée.

Lieferumfang:

Inklusive Präzisions-Spannmutter

Delivery:

With precision clamping nut

Livraison:

Avec écrou de serrage de précision





1



Verwendung:
Zur Aufnahme von Werkzeugen mit Zylinderschaft nach DIN 1835 Form A+B+E und DIN 6535 Form HB+HE

Application:
For mounting straight-shank tools acc. DIN 1835 form A+B+E and DIN 6535 form HB+HE

Utilisation:
Pour la fixation d'outils à queue cylindrique selon DIN 1835 forme A+B+E et DIN 6535 forme HB+HE

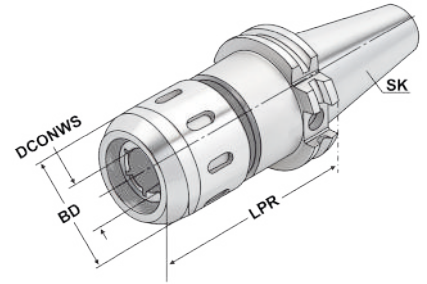

ISO 7388-1	Form AD/AF (AD/B)	≤ 3µm	G6.3 15.000 min ⁻¹	RFID Chip	HKS	13.04
------------	-------------------	-------	-------------------------------	-----------	-----	-------

Bestell-Nr. Order no. Référence	SK	DCONWS Spannbereich Capacity Capacité	Typ	DCONWS	LPR	BD
403.64.20	SK 40	3 - 20	HKS 20	20	90	53
403.64.25	SK 40	3 - 25	HKS 25	25	105	63
403.64.32	SK 40	3 - 32	HKS 32	32	105	68
503.64.20	SK 50	3 - 20	HKS 20	20	90	53
503.64.25	SK 50	3 - 25	HKS 25	25	90	63
503.64.32	SK 50	3 - 32	HKS 32	32	90	68

Größe Size Taille	20mm	25mm	32mm
Anzugsmoment Clamping torque Couple de serrage	50-70 Nm	80-100 Nm	80-100 Nm
Spannkraft Clamping force Force de serrage	780 Nm	2000 Nm	2000 Nm

Gewuchtete Ausführung

Balanced type
Version équilibrée

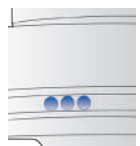

Bestell-Nr. Order no. Référence	Abmessung Size Dimension
---------------------------------------	--------------------------------

Wuchten auf G 2,5 von vorgewuchteten Kemmler-Werkzeugen

Balancing at G 2.5 of pre-balanced Kemmler-tools
Équilibrage G 2,5 d'outils Kemmler pré-équilibrés

W25 **Ohne Wuchtprotokoll**
Without balancing report
Sans protocole d'équilibrage

W25.2 **Mit Wuchtprotokoll**
With balancing report
Avec protocole d'équilibrage

Wuchten von nicht vorgewuchteten Werkzeugen
Balancing of unbalanced tools
Équilibrage d'outils non-équilibrés

W25.1 **Ohne Wuchtprotokoll**
Without balancing report
Sans protocole d'équilibrage

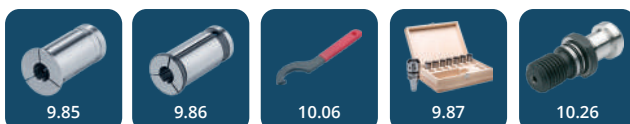

End mill holders DIN 6359 for end mills DIN 1835-B

[DIN 69871]

Porte-fraises DIN 6359 pour queues cylindriques DIN 1835-B

1

**Verwendung:**

Zum Spannen von zylindrischen Werkzeugschäften mit seitlicher Spannfläche nach DIN 1835 Form B (Weldon).

Application:

For mounting straight-shank tools with lateral flat according to DIN 1835 form B (Weldon).

Utilisation:

Pour le serrage d'outils à queue cylindrique et avec la surface de serrage latérale selon DIN 1835 forme B (Weldon).

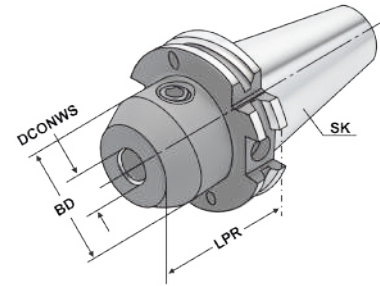

Bestell-Nr. Order no. Référence	SK	DCONWS	TDCON	LPR	BD
302.04.06	SK 30	6	H4	50	25
302.04.08	SK 30	8	H4	50	28
302.04.10	SK 30	10	H4	50	35
302.04.12	SK 30	12	H4	50	42
302.04.14	SK 30	14	H4	63	44
302.04.16	SK 30	16	H4	63	48
302.04.18	SK 30	18	H4	63	50
302.04.20	SK 30	20	H4	70	52
402.04.06	SK 40	6	H4	50	25
402.04.08	SK 40	8	H4	50	28
402.04.10	SK 40	10	H4	50	35
402.04.12	SK 40	12	H4	50	42
402.04.14	SK 40	14	H4	50	44
402.04.16	SK 40	16	H4	63	48
402.04.18	SK 40	18	H4	63	50
402.04.20	SK 40	20	H4	63	52
402.04.25	SK 40	25	H4	100	65
402.04.32	SK 40	32	H4	100	72
402.04.06.1	SK 40	6	H4	100	25
402.04.08.1	SK 40	8	H4	100	28
402.04.10.1	SK 40	10	H4	100	35
402.04.12.1	SK 40	12	H4	100	42
402.04.14.1	SK 40	14	H4	100	44
402.04.16.1	SK 40	16	H4	100	48
402.04.18.1	SK 40	18	H4	100	50
402.04.20.1	SK 40	20	H4	100	52

Hinweis: Ab DCONWS = 25 mit zwei Spannschrauben
Note: From DCONWS = 25 on two clamping screws
Remarque: À partir de DCONWS = 25 avec deux vis de serrage

Lieferumfang: Mit Spannschraube
Delivery: With clamping screw
Livraison: Avec vis de serrage



1



Verwendung:

Zum Spannen von zylindrischen Werkzeugschäften mit seitlicher Spannfläche nach DIN 1835 Form B (Weldon).

Application:

For mounting straight-shank tools with lateral flat according to DIN 1835 form B (Weldon).

Utilisation:

Pour le serrage d'outils à queue cylindrique et avec la surface de serrage latérale selon DIN 1835 forme B (Weldon).

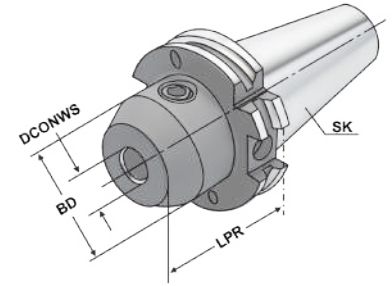

Bestell-Nr. Order no. Référence	SK	DCONWS	TDCON	LPR	BD
403.04.16.0	SK 40	16	H4	35	45
403.04.20.0	SK 40	20	H4	35	45
403.04.25.0	SK 40	25	H4	35	45
403.04.32.0	SK 40	32	H4	65	50
403.04.06	SK 40	6	H4	50	25
403.04.08	SK 40	8	H4	50	28
403.04.10	SK 40	10	H4	50	35
403.04.12	SK 40	12	H4	50	42
403.04.14	SK 40	14	H4	50	44
403.04.16	SK 40	16	H4	63	48
403.04.18	SK 40	18	H4	63	50
403.04.20	SK 40	20	H4	63	52
403.04.25	SK 40	25	H4	100	65
403.04.32	SK 40	32	H4	100	72
403.04.40	SK 40	40	H4	120	80
403.04.06.1	SK 40	6	H4	100	25
403.04.08.1	SK 40	8	H4	100	28
403.04.10.1	SK 40	10	H4	100	35
403.04.12.1	SK 40	12	H4	100	42
403.04.14.1	SK 40	14	H4	100	44
403.04.16.1	SK 40	16	H4	100	48
403.04.18.1	SK 40	18	H4	100	50
403.04.20.1	SK 40	20	H4	100	52

Hinweis: Ab DCONWS = 25 mit zwei Spannschrauben
Note: From DCONWS = 25 on two clamping screws
Remarque: À partir de DCONWS = 25 avec deux vis de serrage

Lieferumfang: Mit Spannschraube
Delivery: With clamping screw
Livraison: Avec vis de serrage



End mill holders DIN 6359 for end mills DIN 1835-B

[DIN 69871]

Porte-fraises DIN 6359 pour queues cylindriques DIN 1835-B

1

**Verwendung:**

Zum Spannen von zylindrischen Werkzeugschäften mit seitlicher Spannfläche nach DIN 1835 Form B (Weldon).

Application:

For mounting straight-shank tools with lateral flat according to DIN 1835 form B (Weldon).

Utilisation:

Pour le serrage d'outils à queue cylindrique et avec la surface de serrage latérale selon DIN 1835 forme B (Weldon).

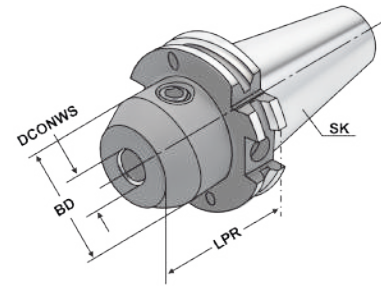

Bestell-Nr.
Order no.
Référence

Bestell-Nr. Order no. Référence	SK	DCONWS	TDCON	LPR	BD
403.04.06.130	SK 40	6	H4	130	25
403.04.08.130	SK 40	8	H4	130	28
403.04.10.130	SK 40	10	H4	130	35
403.04.12.130	SK 40	12	H4	130	42
403.04.14.130	SK 40	14	H4	130	44
403.04.16.130	SK 40	16	H4	130	48
403.04.18.130	SK 40	18	H4	130	50
403.04.20.130	SK 40	20	H4	130	52
403.04.06.2	SK 40	6	H4	160	25
403.04.08.2	SK 40	8	H4	160	28
403.04.10.2	SK 40	10	H4	160	35
403.04.12.2	SK 40	12	H4	160	42
403.04.14.2	SK 40	14	H4	160	44
403.04.16.2	SK 40	16	H4	160	48
403.04.18.2	SK 40	18	H4	160	50
403.04.20.2	SK 40	20	H4	160	52
403.04.25.2	SK 40	25	H4	160	65
403.04.32.2	SK 40	32	H4	160	72
403.04.40.2	SK 40	40	H4	160	80

Nachträgliches Erodieren von 2 Kühlkanalbohrungen*Supplementary eroding of 2 cooling channels*

Erodage complémentaire de 2 trous de canaux de refroidissement

Bestell-Nr.
Order no.
Référence

U.KKB



10.64



10.26

1



Verwendung:
 Zum Spannen von zylindrischen Werkzeugschäften mit seitlicher Spannfläche nach DIN 1835 Form B (Weldon).

Application:
 For mounting straight-shank tools with lateral flat according to DIN 1835 form B (Weldon).

Utilisation:
 Pour le serrage d'outils à queue cylindrique et avec la surface de serrage latérale selon DIN 1835 forme B (Weldon).

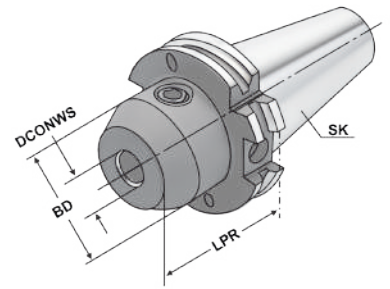

ISO 7388-1	Form AD/AF (AD/B)	$\leq 3\mu\text{m}$	G2.5 25.000 min ⁻¹	RFID Chip	DIN 1835-B	H4	13.04
------------	-------------------	---------------------	-------------------------------	-----------	------------	----	-------

Bestell-Nr. Order no. Référence	SK	DCONWS	TDCON	LPR	BD
503.04.06	SK 50	6	H4	63	25
503.04.08	SK 50	8	H4	63	28
503.04.10	SK 50	10	H4	63	35
503.04.12	SK 50	12	H4	63	42
503.04.14	SK 50	14	H4	63	44
503.04.16	SK 50	16	H4	63	48
503.04.18	SK 50	18	H4	63	50
503.04.20	SK 50	20	H4	63	52
503.04.25	SK 50	25	H4	80	65
503.04.32	SK 50	32	H4	100	72
503.04.40	SK 50	40	H4	100	80
503.04.50	SK 50	50	H4	120	99
503.04.06.1	SK 50	6	H4	100	25
503.04.08.1	SK 50	8	H4	100	28
503.04.10.1	SK 50	10	H4	100	35
503.04.12.1	SK 50	12	H4	100	42
503.04.14.1	SK 50	14	H4	100	44
503.04.16.1	SK 50	16	H4	100	48
503.04.18.1	SK 50	18	H4	100	50
503.04.20.1	SK 50	20	H4	100	52
503.04.25.1	SK 50	25	H4	120	65
503.04.06.130	SK 50	6	H4	130	25
503.04.08.130	SK 50	8	H4	130	28
503.04.10.130	SK 50	10	H4	130	35
503.04.12.130	SK 50	12	H4	130	42
503.04.14.130	SK 50	14	H4	130	44
503.04.16.130	SK 50	16	H4	130	48
503.04.18.130	SK 50	18	H4	130	50
503.04.20.130	SK 50	20	H4	130	52



End mill holders DIN 6359 for end mills DIN 1835-B

[DIN 69871]

Porte-fraises DIN 6359 pour queues cylindriques DIN 1835-B

**Verwendung:**

Zum Spannen von zylindrischen Werkzeugschäften mit seitlicher Spannfläche nach DIN 1835 Form B (Weldon).

Application:

For mounting straight-shank tools with lateral flat according to DIN 1835 form B (Weldon).

Utilisation:

Pour le serrage d'outils à queue cylindrique et avec la surface de serrage latérale selon DIN 1835 forme B (Weldon).

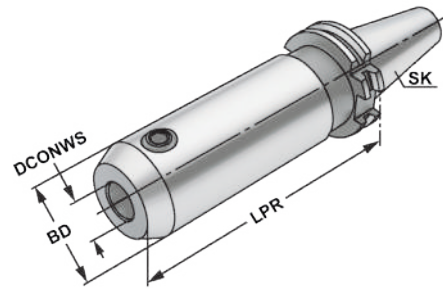

1



Bestell-Nr. Order no. Référence	SK	DCONWS	TDCON	LPR	BD
503.04.06.2	SK 50	6	H4	160	25
503.04.08.2	SK 50	8	H4	160	28
503.04.10.2	SK 50	10	H4	160	35
503.04.12.2	SK 50	12	H4	160	42
503.04.14.2	SK 50	14	H4	160	44
503.04.16.2	SK 50	16	H4	160	48
503.04.18.2	SK 50	18	H4	160	50
503.04.20.2	SK 50	20	H4	160	52
503.04.25.2	SK 50	25	H4	160	65
503.04.32.2	SK 50	32	H4	160	72
503.04.40.2	SK 50	40	H4	160	80
503.04.06.3	SK 50	6	H4	200	25
503.04.08.3	SK 50	8	H4	200	28
503.04.10.3	SK 50	10	H4	200	35
503.04.12.3	SK 50	12	H4	200	42
503.04.14.3	SK 50	14	H4	200	44
503.04.16.3	SK 50	16	H4	200	48
503.04.18.3	SK 50	18	H4	200	50
503.04.20.3	SK 50	20	H4	200	52
503.04.25.3	SK 50	25	H4	200	65
503.04.32.3	SK 50	32	H4	200	72
503.04.40.3	SK 50	40	H4	200	80

Hinweis: Ab DCONWS = 25 mit zwei Spannschrauben
Note: From DCONWS = 25 on two clamping screws
Remarque: À partir de DCONWS = 25 avec deux vis de serrage

Lieferumfang: Mit Spannschraube
Delivery: With clamping screw
Livraison: Avec vis de serrage



End mill holders DIN 6359 with coolant channels for end mills DIN 1835-B
Porte-fraises DIN 6359 avec canaux d'arrosage pour queues cylindriques DIN 1835-B

1



Verwendung:

Zum Spannen von zylindrischen Werkzeugschäften mit seitlicher Spannfläche nach DIN 1835 Form B (Weldon). Mit Kühlkanälen für optimale Kühlung der Werkzeugschneide.

Application:

For mounting straight-shank tools with lateral flat according to DIN 1835 form B (Weldon). With coolant channels for optimal coolant at the cutting edge.

Application:

Pour le serrage d'outils à queue cylindrique et avec la surface de serrage latérale selon DIN 1835 forme B (Weldon). Avec canaux d'arrosage pour refroidissement optimal du tranchant d'outil.

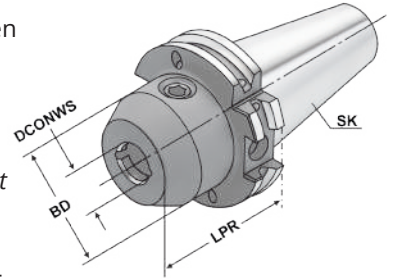

ISO 7388-1

Form AD/AF (AD/B)

≤ 3µm

G2.5 25.000 min⁻¹

RFID Chip

DIN 1835-B

H4

13.04

Bestell-Nr. Order no. Référence	SK	DCONWS	TDCON	LPR	BD
403.04.06.K	SK 40	6	H4	50	25
403.04.08.K	SK 40	8	H4	50	28
403.04.10.K	SK 40	10	H4	50	35
403.04.12.K	SK 40	12	H4	50	42
403.04.14.K	SK 40	14	H4	50	44
403.04.16.K	SK 40	16	H4	63	48
403.04.18.K	SK 40	18	H4	63	50
403.04.20.K	SK 40	20	H4	63	52
403.04.25.K	SK 40	25	H4	100	65
403.04.32.K	SK 40	32	H4	100	72
403.04.40.K	SK 40	40	H4	120	80
403.04.06.1.K	SK 40	6	H4	100	25
403.04.08.1.K	SK 40	8	H4	100	28
403.04.10.1.K	SK 40	10	H4	100	35
403.04.12.1.K	SK 40	12	H4	100	42
403.04.14.1.K	SK 40	14	H4	100	44
403.04.16.1.K	SK 40	16	H4	100	48
403.04.18.1.K	SK 40	18	H4	100	50
403.04.20.1.K	SK 40	20	H4	100	52

Hinweis: Ab DCONWS = 25 mit zwei Spannschrauben
DCONWS = 6 bis 18 mit zwei Kühlkanälen
DCONWS = 20 bis 40 mit vier Kühlkanälen
Für Werkzeuge mit innerer Kühlmittelzufuhr muss ein O-Ring eingesetzt werden.

Note: From DCONWS = 25 on two clamping screws
DCONWS = 6 to 18 with two coolant channels
DCONWS = 20 to 40 with four coolant channels
For tools with through coolant an O-ring must be used.

Remarque: À partir de DCONWS = 25 avec deux vis de serrage
DCONWS = 6 bis 18 avec deux canaux d'arrosage
DCONWS = 20 bis 40 avec quatre canaux d'arrosage
Pour outils avec arrosage interne il faut utiliser un joint torique.

Lieferumfang: Mit Spannschraube und O-Ring
Delivery: With clamping screw and O-ring
Livraison: Avec vis de serrage et joint torique



End mill holders DIN 6359 with coolant channels for end mills DIN 1835-B

Porte-fraises DIN 6359 avec canaux d'arrosage pour queues cylindriques DIN 1835-B

Verwendung:

Zum Spannen von zylindrischen Werkzeugschäften mit seitlicher Spannfläche nach DIN 1835 Form B (Weldon). Mit Kühlkanälen für optimale Kühlung der Werkzeugschneide.

Application:

For mounting straight-shank tools with lateral flat according to DIN 1835 form B (Weldon). With coolant channels for optimal coolant at the cutting edge.

Application:

Pour le serrage d'outils à queue cylindrique et avec la surface de serrage latérale selon DIN 1835 forme B (Weldon). Avec canaux d'arrosage pour refroidissement optimal du tranchant d'outil.

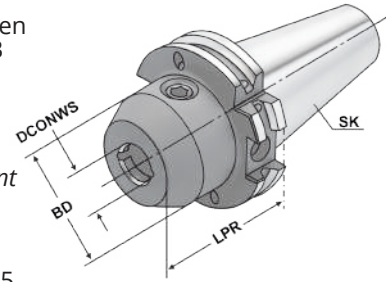

1



Bestell-Nr.
Order no.
Référence

SK

DCONWS

TDCON

LPR

BD

403.04.06.130.K

SK 40

6

H4

130

25

403.04.08.130.K

SK 40

8

H4

130

28

403.04.10.130.K

SK 40

10

H4

130

35

403.04.12.130.K

SK 40

12

H4

130

42

403.04.14.130.K

SK 40

14

H4

130

44

403.04.16.130.K

SK 40

16

H4

130

48

403.04.18.130.K

SK 40

18

H4

130

50

403.04.20.130.K

SK 40

20

H4

130

52

403.04.06.2.K

SK 40

6

H4

160

25

403.04.08.2.K

SK 40

8

H4

160

28

403.04.10.2.K

SK 40

10

H4

160

35

403.04.12.2.K

SK 40

12

H4

160

42

403.04.14.2.K

SK 40

14

H4

160

44

403.04.16.2.K

SK 40

16

H4

160

48

403.04.18.2.K

SK 40

18

H4

160

50

403.04.20.2.K

SK 40

20

H4

160

52

Hinweis:

Ab DCONWS = 25 mit zwei Spannschrauben

DCONWS = 6 bis 18 mit zwei Kühlkanälen

DCONWS = 20 bis 40 mit vier Kühlkanälen

Für Werkzeuge mit innerer Kühlmittelzufuhr muss ein O-Ring eingesetzt werden.

Note:

From DCONWS = 25 on two clamping screws

DCONWS = 6 to 18 with two coolant channels

DCONWS = 20 to 40 with four coolant channels

For tools with through coolant an O-ring must be used.

Remarque:

À partir de DCONWS = 25 avec deux vis de serrage

DCONWS = 6 bis 18 avec deux canaux d'arrosage

DCONWS = 20 bis 40 avec quatre canaux d'arrosage

Pour outils avec arrosage interne il faut utiliser un joint torique.

Lieferumfang:

Mit Spannschraube und O-Ring

Delivery:

With clamping screw and O-ring

Livraison:

Avec vis de serrage et joint torique



End mill holders DIN 6359 with coolant channels for end mills DIN 1835-B
Porte-fraises DIN 6359 avec canaux d'arrosage pour queues cylindriques DIN 1835-B

1



Verwendung:

Zum Spannen von zylindrischen Werkzeugschäften mit seitlicher Spannfläche nach DIN 1835 Form B (Weldon). Mit Kühlkanälen für optimale Kühlung der Werkzeugschneide.

Application:

For mounting straight-shank tools with lateral flat according to DIN 1835 form B (Weldon). With coolant channels for optimal coolant at the cutting edge.

Application:

Pour le serrage d'outils à queue cylindrique et avec la surface de serrage latérale selon DIN 1835 forme B (Weldon). Avec canaux d'arrosage pour refroidissement optimal du tranchant d'outil.

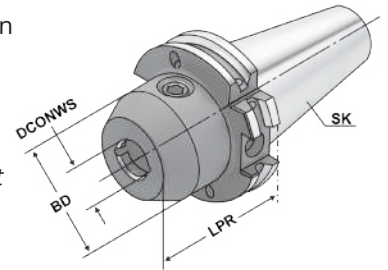

ISO 7388-1

Form AD/AF (AD/B)

≤ 3µm

G2.5 25.000 min

RFID Chip

DIN 1835-B

H4

13.04

Bestell-Nr. Order no. Référence	SK	DCONWS	TDCON	LPR	BD
503.04.06.K	SK 50	6	H4	63	25
503.04.08.K	SK 50	8	H4	63	28
503.04.10.K	SK 50	10	H4	63	35
503.04.12.K	SK 50	12	H4	63	42
503.04.14.K	SK 50	14	H4	63	44
503.04.16.K	SK 50	16	H4	63	48
503.04.18.K	SK 50	18	H4	63	50
503.04.20.K	SK 50	20	H4	63	52
503.04.25.K	SK 50	25	H4	80	65
503.04.32.K	SK 50	32	H4	100	72
503.04.40.K	SK 50	40	H4	100	80
503.04.06.1.K	SK 50	6	H4	100	25
503.04.08.1.K	SK 50	8	H4	100	28
503.04.10.1.K	SK 50	10	H4	100	35
503.04.12.1.K	SK 50	12	H4	100	42
503.04.14.1.K	SK 50	14	H4	100	44
503.04.16.1.K	SK 50	16	H4	100	48
503.04.18.1.K	SK 50	18	H4	100	50
503.04.20.1.K	SK 50	20	H4	100	52

Hinweis: Ab DCONWS = 25 mit zwei Spannschrauben
DCONWS = 6 bis 18 mit zwei Kühlkanälen
DCONWS = 20 bis 40 mit vier Kühlkanälen
Für Werkzeuge mit innerer Kühlmittelzufuhr muss ein O-Ring eingesetzt werden.

Note: From DCONWS = 25 on two clamping screws
DCONWS = 6 to 18 with two coolant channels
DCONWS = 20 to 40 with four coolant channels
For tools with through coolant an O-ring must be used.

Remarque: À partir de DCONWS = 25 avec deux vis de serrage
DCONWS = 6 bis 18 avec deux canaux d'arrosage
DCONWS = 20 bis 40 avec quatre canaux d'arrosage
Pour outils avec arrosage interne il faut utiliser un joint torique.

Lieferumfang: Mit Spannschraube und O-Ring
Delivery: With clamping screw and O-ring
Livraison: Avec vis de serrage et joint torique



End mill holders DIN 6359 with coolant channels for end mills DIN 1835-B

Porte-fraises DIN 6359 avec canaux d'arrosage pour queues cylindriques DIN 1835-B

**Verwendung:**

Zum Spannen von zylindrischen Werkzeugschäften mit seitlicher Spannfläche nach DIN 1835 Form B (Weldon). Mit Kühlkanälen für optimale Kühlung der Werkzeugschneide.

Application:

For mounting straight-shank tools with lateral flat according to DIN 1835 form B (Weldon). With coolant channels for optimal coolant at the cutting edge.

Application:

Pour le serrage d'outils à queue cylindrique et avec la surface de serrage latérale selon DIN 1835 forme B (Weldon). Avec canaux d'arrosage pour refroidissement optimal du tranchant d'outil.

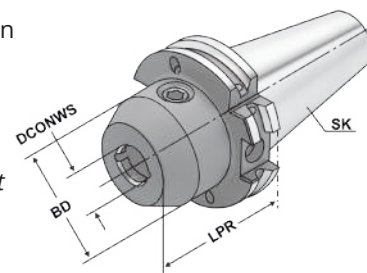

1



Bestell-Nr.
Order no.
Référence

SK

DCONWS

TDCON

LPR

BD

503.04.06.130.K

SK 50

6

H4

130

25

503.04.08.130.K

SK 50

8

H4

130

28

503.04.10.130.K

SK 50

10

H4

130

35

503.04.12.130.K

SK 50

12

H4

130

42

503.04.14.130.K

SK 50

14

H4

130

44

503.04.16.130.K

SK 50

16

H4

130

48

503.04.18.130.K

SK 50

18

H4

130

50

503.04.20.130.K

SK 50

20

H4

130

52

503.04.25.130.K

SK 50

25

H4

130

65

503.04.32.130.K

SK 50

32

H4

130

72

503.04.40.130.K

SK 50

40

H4

130

80

503.04.06.2.K

SK 50

6

H4

160

25

503.04.08.2.K

SK 50

8

H4

160

28

503.04.10.2.K

SK 50

10

H4

160

35

503.04.12.2.K

SK 50

12

H4

160

42

503.04.14.2.K

SK 50

14

H4

160

44

503.04.16.2.K

SK 50

16

H4

160

48

503.04.18.2.K

SK 50

18

H4

160

50

503.04.20.2.K

SK 50

20

H4

160

52

503.04.25.2.K

SK 50

25

H4

160

65

503.04.32.2.K

SK 50

32

H4

160

72

503.04.40.2.K

SK 50

40

H4

160

80

Hinweis:

Ab DCONWS = 25 mit zwei Spannschrauben
DCONWS = 6 bis 18 mit zwei Kühlkanälen
DCONWS = 20 bis 40 mit vier Kühlkanälen

Für Werkzeuge mit innerer Kühlmittelzufuhr muss ein O-Ring eingesetzt werden.

Note:

From DCONWS = 25 on two clamping screws
DCONWS = 6 to 18 with two coolant channels
DCONWS = 20 to 40 with four coolant channels

For tools with through coolant an O-ring must be used.

Remarque:

À partir de DCONWS = 25 avec deux vis de serrage
DCONWS = 6 bis 18 avec deux canaux d'arrosage
DCONWS = 20 bis 40 avec quatre canaux d'arrosage

Pour outils avec arrosage interne il faut utiliser un joint torique.

Lieferumfang:

Mit Spannschraube und O-Ring

Delivery:

With clamping screw and O-ring

Livraison:

Avec vis de serrage et joint torique



1



Verwendung:
 Zum Spannen von zylindrischen Werkzeugschäften mit geneigter Spannfläche nach DIN 1835 Form E (Whistle Notch).

Application:
 For mounting straight-shank tools and inclined flat according to DIN 1835 form E (Whistle Notch).

Application:
 Pour le serrage d'outils à queue cylindrique avec la surface de serrage incliné selon DIN 1835 forme E (Whistle notch).

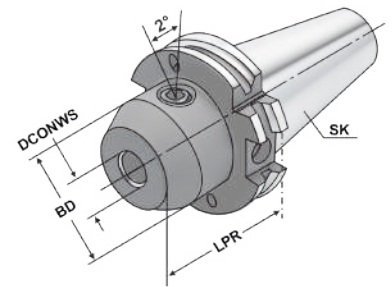

ISO 7388-1	Form AD/AF (AD/B)	$\leq 3\mu\text{m}$	G2.5 25.000 min ⁻¹	RFID Chip	DIN 1835-E	H4	13.04
------------	-------------------	---------------------	-------------------------------	-----------	------------	----	-------

Bestell-Nr. Order no. Référence	SK	DCONWS	TDCON	LPR	BD
403.05.06	SK 40	6	H4	50	25
403.05.08	SK 40	8	H4	50	28
403.05.10	SK 40	10	H4	50	35
403.05.12	SK 40	12	H4	50	42
403.05.14	SK 40	14	H4	50	44
403.05.16	SK 40	16	H4	63	48
403.05.18	SK 40	18	H4	63	50
403.05.20	SK 40	20	H4	63	52
403.05.25	SK 40	25	H4	100	65
403.05.32	SK 40	32	H4	100	72
403.05.40	SK 40	40	H4	120	80
503.05.06	SK 50	6	H4	63	25
503.05.08	SK 50	8	H4	63	28
503.05.10	SK 50	10	H4	63	35
503.05.12	SK 50	12	H4	63	42
503.05.14	SK 50	14	H4	63	44
503.05.16	SK 50	16	H4	63	48
503.05.18	SK 50	18	H4	63	50
503.05.20	SK 50	20	H4	63	52
503.05.25	SK 50	25	H4	80	65
503.05.32	SK 50	32	H4	100	72
503.05.40	SK 50	40	H4	100	80

Hinweis: Ab DCONWS = 25 mit zwei Spannschrauben
Note: From DCONWS = 25 on two clamping screws
Remarque: À partir de DCONWS = 25 avec deux vis de serrage

Lieferumfang: Mit Spannschraube und axialer Verstellechraube
Delivery: With clamping screw and axial adjustment bolt
Livraison: Avec vis de serrage et vis de réglage



Milling arbors for screw-in cutters

Mandrins porte fraise pour fraises à visser

[DIN 69871]

1

**Verwendung:**

Zur Aufnahme von Einschraubfräser mit Gewinde.

Application:

For mounting screw-in cutters with thread.

Application:

Pour la fixation de fraise à visser avec filetage

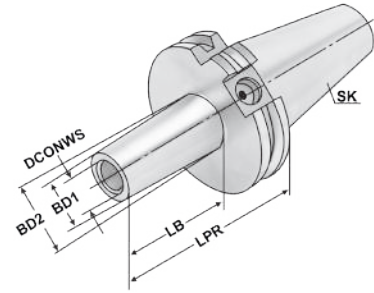

Bestell-Nr. Order no. Référence	SK	THSZWS	DCONWS	BD1	BD2	LPR	LB
403.06.06	SK 40	M6	6,5	10	13	44	25
403.06.06.1	SK 40	M6	6,5	10	13	69	50
403.06.06.2	SK 40	M6	6,5	10	13	94	75
403.06.08	SK 40	M8	8,5	13	15	44	25
403.06.08.1	SK 40	M8	8,5	13	23	69	50
403.06.08.2	SK 40	M8	8,5	13	23	94	75
403.06.08.3	SK 40	M8	8,5	13	25	119	100
403.06.10.0	SK 40	M10	10,5	18	18	24	5
403.06.10	SK 40	M10	10,5	18	20	44	25
403.06.10.1	SK 40	M10	10,5	18	23	69	50
403.06.10.2	SK 40	M10	10,5	18	28	94	75
403.06.10.3	SK 40	M10	10,5	18	32	119	100
403.06.10.5	SK 40	M10	10,5	18	37	169	150
403.06.12.0	SK 40	M12	12,5	21	21	24	5
403.06.12	SK 40	M12	12,5	21	24	44	25
403.06.12.1	SK 40	M12	12,5	21	24	69	50
403.06.12.2	SK 40	M12	12,5	21	31	94	75
403.06.12.3	SK 40	M12	12,5	21	33	119	100
403.06.12.5	SK 40	M12	12,5	21	40	169	150
403.06.16.0	SK 40	M16	17	29	29	24	5
403.06.16	SK 40	M16	17	29	29	44	25
403.06.16.1	SK 40	M16	17	29	34	69	50
403.06.16.2	SK 40	M16	17	29	34	94	75
403.06.16.3	SK 40	M16	17	29	36	119	100
403.06.16.5	SK 40	M16	17	29	43	169	150
503.06.08.1	SK 50	M8	8,5	13	23	69	50
503.06.08.3	SK 50	M8	8,5	13	25	119	100
503.06.08.5	SK 50	M8	8,5	13	30	169	150
503.06.10.1	SK 50	M10	10,5	18	23	69	50
503.06.10.3	SK 50	M10	10,5	18	32	119	100
503.06.10.5	SK 50	M10	10,5	18	37	169	150
503.06.12.1	SK 50	M12	12,5	21	24	69	50
503.06.12.3	SK 50	M12	12,5	21	33	119	100
503.06.12.5	SK 50	M12	12,5	21	40	169	150
503.06.16.1	SK 50	M16	17	29	34	69	50
503.06.16.3	SK 50	M16	17	29	36	119	100
503.06.16.5	SK 50	M16	17	29	43	169	150



1



Verwendung:

Zur Aufnahme von Werkzeugen mit Morsekegelschaft und Austreibblappen nach DIN 228-1 Form B.

Application:

For mounting tools with Morse taper shank and tang according to DIN 228-1 form B.

Utilisation:

Pour le serrage d'outils avec la queue au cône morse et tenon de déblocage selon DIN 228-1 forme B.

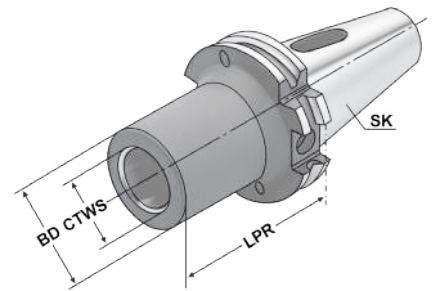

ISO 7388-1 Form AD/AF (AD/B) $\leq 5\mu\text{m}$ G6.3 15.000 min⁻¹ RFID Chip DIN 6383 AT5

Bestell-Nr. Order no. Référence	SK	CTWS	TDCON	LPR	BD
302.07.01*	SK 30	1	AT5	50	25
302.07.02*	SK 30	2	AT5	60	32
302.07.03*	SK 30	3	AT5	80	40
402.07.01*	SK 40	1	AT5	50	25
402.07.02*	SK 40	2	AT5	50	32
402.07.03*	SK 40	3	AT5	70	40
402.07.04*	SK 40	4	AT5	95	48
403.07.01	SK 40	1	AT5	50	25
403.07.02	SK 40	2	AT5	50	32
403.07.03	SK 40	3	AT5	70	40
403.07.04	SK 40	4	AT5	95	48
402.07.02.1*	SK 40	2	AT5	117	32
402.07.03.1*	SK 40	3	AT5	133	40
402.07.04.1*	SK 40	4	AT5	156	48
503.07.01	SK 50	1	AT5	45	25
503.07.02	SK 50	2	AT5	60	32
503.07.03	SK 50	3	AT5	65	40
503.07.04	SK 50	4	AT5	95	48
503.07.05	SK 50	5	AT5	105	63
502.07.02.1*	SK 50	2	AT5	117	32
502.07.03.1*	SK 50	3	AT5	137	40
502.07.04.1*	SK 50	4	AT5	167	48
502.07.05.1*	SK 50	5	AT5	197	63

* Form AD
* Form AD
* Forme AD



Adaptor sleeves for MT with drawbar thread DIN 6364
 Douilles de réduction pour CM avec filetage DIN 6364

[DIN 69871]



Verwendung:
 Zum Spannen von Werkzeugen mit Morsekegelschaft und Anzugsgewinde nach DIN 228-1 Form A.

Application:
 For clamping tools with Morse taper shank and thread according to DIN 228-1 form A.

Utilisation:
 Pour le serrage d'outils avec la queue au cône morse et filetage selon DIN 228-1 forme A.

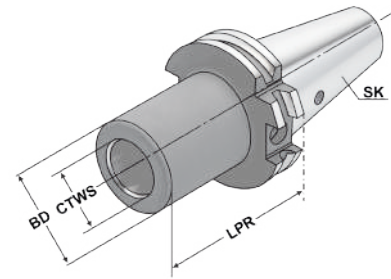

ISO 7388-1 Form A ≤ 5µm G6.3 15.000 min⁻¹ RFID Chip DIN 6364 AT5

Bestell-Nr. Order no. Référence	SK	CTWS	THID	LPR	BD
402.08.01	SK 40	1	M6	50	25
402.08.02	SK 40	2	M10	50	32
402.08.03	SK 40	3	M12	70	40
402.08.04	SK 40	4	M16	95	48
402.08.04A*	SK 40	4	M16	110	63
502.08.01	SK 50	1	M6	45	25
502.08.02	SK 50	2	M10	60	32
502.08.03	SK 50	3	M12	65	40
502.08.04	SK 50	4	M16	70	48
502.08.04A*	SK 50	4	M16	85	63
502.08.05	SK 50	5	M20	100	63
502.08.05A*	SK 50	5	M20	118	78

* Mit Mitnahmeausfräsung nach DIN 2201
 * With drive flats according to DIN 2201
 * Avec des fraises d'entraînement suivant DIN 2201

Lieferumfang: Mit eingebauter Fräseranzugsschraube
Delivery: With built-in tightening bolt
Livraison: Avec vis de serrage montée

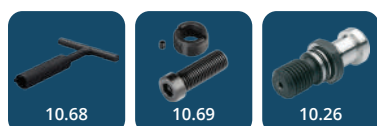



1



Verwendung:
Adapter SK / PSK mit Axialspannung.

Application:
Adapter from ISO to PSC with axial tension

Application:
Adaptateur ISO à PSC avec serrage axial

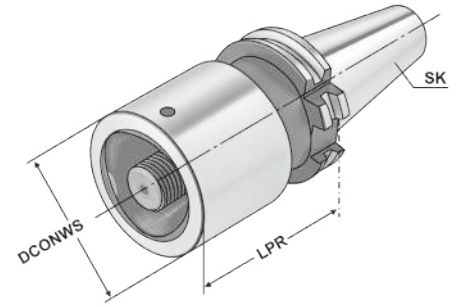

Bestell-Nr. Order no. Référence	SK	Typ	DCONWS	LPR	LB	BD	TQX	THID
402.09.C3	SK 40	PSK C3	32	30	10,9	32	45	M12x1,5
402.09.C4	SK 40	PSK C4	40	40	20,9	40	55	M14x1,5
402.09.C5	SK 40	PSK C5	50	50	30,9	50	95	M16x1,5
402.09.C6	SK 40	PSK C6	63	90	70,9	63	170	M20x2,0

Ausführung:

Adapter SK / PSK mit Axialspannung. Innen und außen geschliffen. Das im PSK-Werkzeughalter für Kühlmittel-Rohre vorgesehene Innengewinde wird mit der im Adapter integrierten Zylinderkopfschraube verschraubt. Spannschraube durchbohrt, somit ist das System für Innenkühlung geeignet.

Passend für Werkzeugaufnahmen mit Polygonschaft (PSC/PSK) ISO 26623-1.

Version:

Adapters SK / PSK with axial clamping. Ground internally and externally. The internal thread provided for the coolant tube in the PSC toolholder is plugged with the socket-head screw incorporated in the adapter. The clamping screw incorporates a through hole, so the system is suitable for through-coolant feed.

Suitable for tool arbor with polygonal shank (PSC) - ISO 26623-1.

Exécution:

Adaptateurs SK / PSK Tension axiale. Intérieur et extérieur rectifiés. Le filetage intérieur prévu pour les conduits d'arrosage dans le porte-outils PSC est vissé à l'aide de la vis à tête cylindrique intégrée dans l'adaptateur. Système adapté à l'arrosage interne grâce à la vis de serrage percée. Pour la réception d'outils PSK ISO 26623-1.

Lieferumfang: Mit Spannschraube
Delivery: Clamping screw
Livraison: Avec vis de serrage





Verwendung:
Zur Aufnahme von Steilkegeln nach DIN 69871, JIS B 6339 und DIN 2080.

Application:
For holding tapers according to DIN 69871, JIS B 6339 and DIN 2080.

Application:
Pour le serrage de porte-outils suivant DIN 69871, JIS B 6339 et DIN 2080.

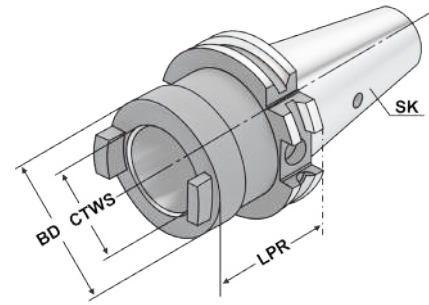

ISO 7388-1 Form A $\leq 5\mu\text{m}$ G6.3 15.000 min⁻¹ RFID Chip AT5

Bestell-Nr. Order no. Référence	SK	CTWS	LPR	BD
402.09.30	SK 40	SK 30	50	50
402.09.40	SK 40	SK 40	100	63
502.09.40	SK 50	SK 40	70	70
502.09.50	SK 50	SK 50	120	97

Hinweis: Lieferung erfolgt mit eingebauter Schraube für Werkzeuge mit gekürztem Steilkegel. Schraube für DIN 2080 Werkzeuge beiliegend.

Note: Delivered with a built-in screw for shortened taper tools. Additional screw for DIN 2080 tools included.

Remarque: Livraison avec un vis incorporée pour outils à cône court. Vis pour cônes DIN 2080 incluse.

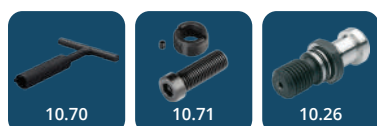

1



Verwendung:

Zur Aufnahme von Walzen-, Walzenstirnfräsern oder Messerköpfen mit Längs- oder Quernut.

Application:

For mounting milling cutters with transverse or longitudinal groove.

Application:

Destiné à recevoir les fraise cylindriques, les fraises frontales cylindriques ou les têtes de fraisage avec rainure longitudinale et transversale.

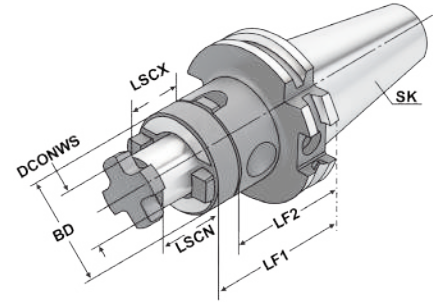

ISO
7388-1

Form
AD/AF
(AD/B)

$\leq 5\mu\text{m}$

G6.3
 15.000
 min⁻¹

RFID
Chip

DIN
6358

h6

Bestell-Nr. Order no. Référence	SK	DCONWS	TDCON	LF1	LF2	LSCN	LSCX	BD
302.10.16*	SK 30	16	h6	50	40	17	27	32
302.10.22*	SK 30	22	h6	50	38	19	31	40
302.10.27*	SK 30	27	h6	55	43	21	33	48
302.10.32*	SK 30	32	h6	60	46	24	38	58
403.10.16	SK 40	16	h6	55	45	17	27	32
403.10.22	SK 40	22	h6	55	43	19	31	40
403.10.27	SK 40	27	h6	55	43	21	33	48
403.10.32	SK 40	32	h6	60	46	24	38	58
403.10.40	SK 40	40	h6	60	46	27	41	70
403.10.16.1	SK 40	16	h6	100	90	17	27	32
403.10.22.1	SK 40	22	h6	100	88	19	31	40
403.10.27.1	SK 40	27	h6	100	88	21	33	48
403.10.32.1	SK 40	32	h6	100	86	24	38	58
403.10.40.1	SK 40	40	h6	100	86	27	41	70
403.10.16.2	SK 40	16	h6	160	150	17	27	32
403.10.22.2	SK 40	22	h6	160	148	19	31	40
403.10.27.2	SK 40	27	h6	160	148	21	33	48
403.10.32.2	SK 40	32	h6	160	146	24	38	58
403.10.40.2	SK 40	40	h6	160	146	27	41	70

* Form AD
* Form AD
* Forme AD

Lieferumfang: Mit Fräseranzugsschraube, Mitnehmerring und Passfeder
Delivery: With retaining screw, driving ring and feather key
Livraison: Avec vis de serrage, bague d'entraînement et clavette





Verwendung:
Zur Aufnahme von Walzen-, Walzenstirnfräsern oder Messerköpfen mit Längs- oder Quernut.

Application:
For mounting milling cutters with transverse or longitudinal groove.

Application:
Destiné à recevoir les fraise cylindriques, les fraises frontales cylindriques ou les têtes de fraisage avec rainure longitudinale et transversale.

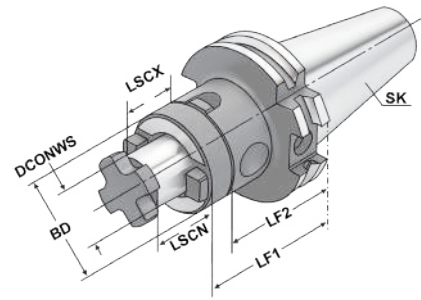

ISO 7388-1 Form AD/AF (AD/B) $\leq 5\mu\text{m}$ G6.3 15.000 min⁻¹ RFID Chip DIN 6358 h6

Bestell-Nr. Order no. Référence	SK	DCONWS	TDCON	LF1	LF2	LSCN	LSCX	BD
503.10.16	SK 50	16	h6	55	45	17	27	32
503.10.22	SK 50	22	h6	55	43	19	31	40
503.10.27	SK 50	27	h6	55	43	21	33	48
503.10.32	SK 50	32	h6	55	41	24	38	58
503.10.40	SK 50	40	h6	55	41	27	41	70
503.10.16.1	SK 50	16	h6	100	90	17	27	32
503.10.22.1	SK 50	22	h6	100	88	19	31	40
503.10.27.1	SK 50	27	h6	100	88	21	33	48
503.10.32.1	SK 50	32	h6	100	86	24	38	58
503.10.40.1	SK 50	40	h6	100	86	27	41	70
503.10.16.2	SK 50	16	h6	160	150	17	27	32
503.10.22.2	SK 50	22	h6	160	148	19	31	40
503.10.27.2	SK 50	27	h6	160	148	21	33	48
503.10.32.2	SK 50	32	h6	160	146	24	38	58
503.10.40.2	SK 50	40	h6	160	146	27	41	70

Lieferumfang: Mit Fräseranzugsschraube, Mitnehmerring und Passfeder
Delivery: With retaining screw, driving ring and feather key
Livraison: Avec vis de serrage, bague d'entraînement et clavette



Nachträgliches Erodieren von 2 Kühlkanalbohrungen

Supplementary eroding of 2 cooling channels

Erodage complémentaire de 2 trous de canaux de refroidissement

Bestell-Nr.
Order no.
Référence

U.KKB

10.62 10.60 10.63 10.63 10.61 10.26



Shell mill holders DIN 6357 with enlarged contact face and coolant exit bores on the end face
 Porte-fraises à trou lisse DIN 6357 avec surface de contact agrandie et arrosage frontal

1



Verwendung:

Zur Aufnahme von Messerköpfen und Fräsern mit Quernut.

Application:

For mounting milling cutters with transversal groove.

Application:

Destiné à recevoir les têtes de fraisage et les fraises avec des rainures transversales.

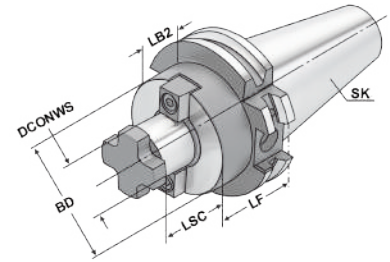

Bestell-Nr. Order no. Référence	SK	DCONWS	TDCON	LF	LSC	LB2	BD
302.11.16 *	SK 30	16	h6	40	17	20,9	38
302.11.22 *	SK 30	22	h6	40	19	20,9	48
302.11.27 *	SK 30	27	h6	50	21	30,9	58
302.11.32 *	SK 30	32	h6	50	24	30,9	78
402.11.16 *	SK 40	16	h6	35	17	15,9	38
402.11.22 *	SK 40	22	h6	35	19	15,9	48
402.11.27 *	SK 40	27	h6	40	21	20,9	58
402.11.32 *	SK 40	32	h6	50	24	30,9	78
402.11.40 *	SK 40	40	h6	50	27	30,9	88
403.11.16	SK 40	16	h6	35	17	15,9	38
403.11.22	SK 40	22	h6	35	19	15,9	48
403.11.27	SK 40	27	h6	40	21	20,9	58
403.11.32	SK 40	32	h6	50	24	30,9	78
403.11.40	SK 40	40	h6	50	27	30,9	88
403.11.16.1	SK 40	16	h6	100	17	80,9	38
403.11.22.1	SK 40	22	h6	100	19	80,9	48
403.11.27.1	SK 40	27	h6	100	21	80,9	58
403.11.32.1	SK 40	32	h6	100	24	80,9	78
403.11.40.1	SK 40	40	h6	100	27	80,9	88
403.11.16.130	SK 40	16	h6	130	17	110,9	38
403.11.22.130	SK 40	22	h6	130	19	110,9	48
403.11.27.130	SK 40	27	h6	130	21	110,9	58
403.11.32.130	SK 40	32	h6	130	24	110,9	78
403.11.40.130	SK 40	40	h6	130	27	110,9	88
403.11.16.2	SK 40	16	h6	160	17	140,9	38
403.11.22.2	SK 40	22	h6	160	19	140,9	48
403.11.27.2	SK 40	27	h6	160	21	140,9	58
403.11.32.2	SK 40	32	h6	160	24	140,9	78
403.11.40.2	SK 40	40	h6	160	27	140,9	88

* Form AD
 * Form AD
 * Forme AD

SK 30 ohne Kühlkanalbohrungen an der Stirnseite
 SK 30 without coolant exit bores on the end face
 SK 30 sans alésages pour l'arrosage frontal

DCONWS = 40 & 60

Für große Planfräser mit vier zusätzlichen Gewindebohrungen nach DIN 2079.
 For large diameter face mill cutters with four additional threaded holes according to DIN 2079.
 Pour fraises à surfacer à grands diamètres avec 4 taraudages supplémentaires suivant DIN 2079.

Shell mill holders DIN 6357 with enlarged contact face and coolant exit bores on the end face

Porte-fraises à trou lisse DIN 6357 avec face de contact élargie et conduits pour l'arrosage frontal



Verwendung:
Zur Aufnahme von Messerköpfen und Fräsern mit Quernut.

Application:
For mounting milling cutters with transversal groove.

Application:
Destiné à recevoir les têtes de fraisage et les fraises avec des rainures transversales.

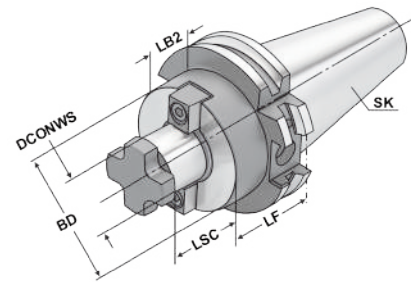

Bestell-Nr. Order no. Référence	SK	DCONWS	TDCON	LF	LSC	LB2	BD
503.11.16	SK 50	16	h6	45	17	25,9	38
503.11.22	SK 50	22	h6	35	19	15,9	48
503.11.27	SK 50	27	h6	40	21	20,9	58
503.11.32	SK 50	32	h6	50	24	30,9	78
503.11.40	SK 50	40	h6	50	27	30,9	88
503.11.60	SK 50	60	h6	70	40	50,9	129
503.11.16.1	SK 50	16	h6	100	17	80,9	38
503.11.22.1	SK 50	22	h6	100	19	80,9	48
503.11.27.1	SK 50	27	h6	100	21	80,9	58
503.11.32.1	SK 50	32	h6	100	24	80,9	78
503.11.40.1	SK 50	40	h6	100	27	80,9	88
503.11.16.130	SK 50	16	h6	130	17	110,9	38
503.11.22.130	SK 50	22	h6	130	19	110,9	48
503.11.27.130	SK 50	27	h6	130	21	110,9	58
503.11.32.130	SK 50	32	h6	130	24	110,9	78
503.11.40.130	SK 50	40	h6	130	27	110,9	88
503.11.16.2	SK 50	16	h6	160	17	140,9	38
503.11.22.2	SK 50	22	h6	160	19	140,9	48
503.11.27.2	SK 50	27	h6	160	21	140,9	58
503.11.32.2	SK 50	32	h6	160	24	140,9	78
503.11.40.2	SK 50	40	h6	160	27	140,9	88
503.11.16.3	SK 50	16	h6	200	17	180,9	38
503.11.22.3	SK 50	22	h6	200	19	180,9	48
503.11.27.3	SK 50	27	h6	200	21	180,9	58
503.11.32.3	SK 50	32	h6	200	24	180,9	78
503.11.40.3	SK 50	40	h6	200	27	180,9	88

Lieferumfang: Mit Mitnehmersteinen, Kreuzschraube und Zylinderkopfschraube nach DIN 912 für Fräser mit innerer Kühlmittelzufuhr.
Bei DCONWS = 60 nur mit vier Befestigungsschrauben nach DIN 912.

Delivery: With drivers, cross head retaining screw and cylinder head retaining screw for cutters with central coolant.
For DCONWS = 60 only with four fixation screws according to DIN 912.

Livraison: Avec tenon d entraînement, vis cruciforme et vis à têtes cylindrique suivant DIN 912 pour les fraises avec arrosage central.
Pour DCONWS = 60 est seulement avec quatre vis de fixation suivant DIN 912.



1



Verwendung:

Zur Aufnahme von allen nach DIN 6595 genormten Vollbohrern mit Zylinderschaft.

Application:

For mounting solid drills with cylindrical shank according to DIN 6595.

Application:

Pour le serrage de forets à queue cylindrique suivant DIN 6595.

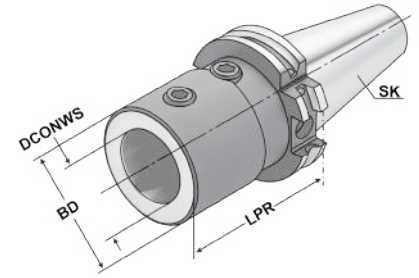

ISO 7388-1	Form AD/AF (AD/B)	$\leq 4\mu\text{m}$	G6.3 15.000 min ⁻¹	RFID Chip	ISO 9766	E1	H4
------------	-------------------	---------------------	-------------------------------	-----------	----------	----	----

Bestell-Nr. Order no. Référence	SK	DCONWS	TDCON	LPR	BD
403.51.20	SK 40	20	H4	65	40
403.51.25	SK 40	25	H4	70	45
403.51.32	SK 40	32	H4	75	52
503.51.20	SK 50	20	H4	70	40
503.51.25	SK 50	25	H4	70	45
503.51.32	SK 50	32	H4	70	52
503.51.40	SK 50	40	H4	80	60

Hinweis: Plangeschliffene Anlagefläche
Note: Contact surface precision grinded
Remarque: Surface d'appui rectifiée

Lieferumfang: Mit Spannschrauben
Delivery: With clamping screws
Livraison: Avec vis de serrage





Verwendung:
Zur Aufnahme von Bohrfuttern.
Application:
For mounting drill chucks.
Application:
Pour le serrage de mandrins de perçage.

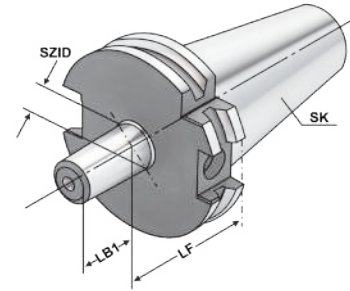

ISO 7388-1 Form A $\leq 5\mu\text{m}$ G6.3 15.000 min⁻¹ RFID Chip DIN 238 AT4

Bestell-Nr. Order no. Référence	SK	SZID	LF	LB1
302.14.12	SK 30	B12	25	18,5
302.14.16	SK 30	B16	25	24
402.14.12	SK 40	B12	25	18,5
402.14.16	SK 40	B16	25	24
402.14.18	SK 40	B18	35	32
502.14.12	SK 50	B12	25	18,5
502.14.16	SK 50	B16	25	24
502.14.18	SK 50	B18	25	32

Gewuchtete Ausführung

Balanced type
Type équilibré



Bestell-Nr. Order no. Référence	Abmessung Size Dimension
---------------------------------------	--------------------------------

Wuchten auf G 2,5 von vorgewuchteten Kemmler-Werkzeugen
Balancing at G 2.5 of pre-balanced Kemmler-tools
Équilibrage G 2,5 d'outils Kemmler pré-équilibrés

W25 **Ohne Wuchtprotokoll**
Without balancing report
Sans protocole d'équilibrage

W25.2 **Mit Wuchtprotokoll**
With balancing report
Avec protocole d'équilibrage

Wuchten von nicht vorgewuchteten Werkzeugen
Balancing of unbalanced tools
Équilibrage d'outils non-équilibrés

W25.1 **Ohne Wuchtprotokoll**
Without balancing report
Sans protocole d'équilibrage



1



Verwendung:
Zur Aufnahme von Werkzeugen mit Zylinderschaft.

Application:
For mounting tools with straight shanks.

Application:
Pour le serrage d'outils avec queue cylindrique.

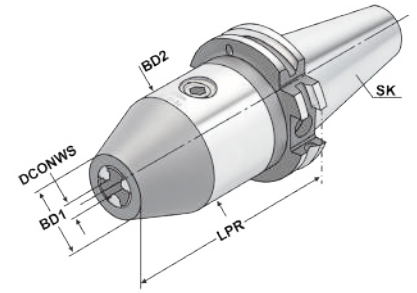

Bestell-Nr. Order no. Référence	SK	DCONWS Spannbereich Capacity Capacité	LPR	BD1	BD2	DRVS
302.15.08	SK 30	0 – 8	70	23	36	4
302.15.13	SK 30	1,0 – 13	111	31,0	50	6
302.15.16	SK 30	2,5 – 16	116	27,5	50	6
402.15.08	SK 40	0 – 8	70	23	36	4
402.15.13	SK 40	1,0 – 13	90	31,0	50	6
402.15.16	SK 40	2,5 – 16	95	27,5	50	6
502.15.13	SK 50	1,0 – 13	90	31,0	50	6
502.15.16	SK 50	2,5 – 16	95	27,5	50	6

Hinweis: Hohe Präzision und Rundlaufgenauigkeit von $\leq 0,03$ mm. Sichere Spannung des Werkzeuges durch mechanische Spannkraftverstärkung. Kein selbständiges Lösen der Spannung während der Bearbeitung bei Links- oder Rechtslauf, sowie bei Spindelstop. Spannen und Lösen mit Sechskantschlüssel.

Note: High precision and accurate concentricity of ≤ 0.03 mm. Secure gripping of the tool through mechanical amplification of the clamping force. No automatic slackening of the clamping force while machining with either clockwise or counter clockwise rotation or on spindle stop. Clamping and releasing effected by means of an Allen wrench.

Remarque: Précision élevée et exactitude de circularité de $\leq 0,03$ mm. Serrage d'outil assuré grâce à la face de serrage mécanique. Pas de desserage autonome pendant l'usinage lors de la rotation à gauche ou à droite, ainsi que lors de l'arrêt de la broche. Serrage et desserage avec la clé hexagonale.

Lieferumfang: Ohne Spannschlüssel
Delivery: Without wrench
Livraison: Sans clé de serrage





Verwendung:
Zur Aufnahme von Werkzeugen mit Zylinderschaft.

Application:
For mounting tools with straight shanks.

Application:
Pour le serrage d'outils avec queue cylindrique.

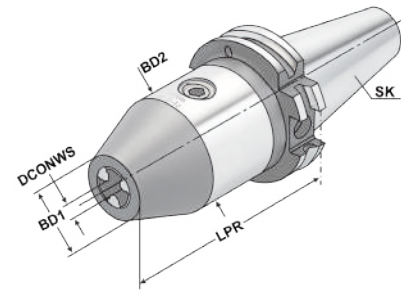

ISO 7388-1 Form AD/AF (AD/B) $\leq 30\mu\text{m}$ G6.3 15.000 min⁻¹ RFID Chip

13.04

Bestell-Nr. Order no. Référence	SK	DCONWS Spannbereich Capacity Capacité	LPR	BD1	BD2	DRVS
403.15.08	SK 40	0 – 8	70	23	36	4
403.15.13	SK 40	1,0 – 13	90	31,0	50	6
403.15.16	SK 40	2,5 – 16	95	27,5	50	6
503.15.13	SK 50	1,0 – 13	90	31,0	50	6
503.15.16	SK 50	2,5 – 16	95	27,5	50	6

Hinweis: Hohe Präzision und Rundlaufgenauigkeit von $\leq 0,03$ mm. Sichere Spannung des Werkzeuges durch mechanische Spannkraftverstärkung. Kein selbständiges Lösen der Spannung während der Bearbeitung bei Links- oder Rechtslauf, sowie bei Spindelstop. Spannen und Lösen mit Sechskantschlüssel.

Note: High precision and accurate concentricity of ≤ 0.03 mm. Secure gripping of the tool through mechanical amplification of the clamping force. No automatic slackening of the clamping force while machining with either clockwise or counter clockwise rotation or on spindle stop. Clamping and releasing effected by means of an Allen wrench.

Remarque: Précision élevée et exactitude de circularité de $\leq 0,03$ mm. Serrage d'outil assuré grâce à la face de serrage mécanique. Pas de desserage autonome pendant l'usinage lors de la rotation à gauche ou à droite, ainsi que lors de l'arrêt de la broche. Serrage et desserage avec la clé hexagonale.

Lieferumfang: Ohne Spannschlüssel
Delivery: Without wrench
Livraison: Sans clé de serrage





1

Quick change tapping chucks **with** length compensation on compression and expansion

Mandrins de taraudage à changement rapide **avec** compensation longitudinale à la compression et traction



Verwendung:

Zur Aufnahme von Schnellwechsel-Ein-sätzen für Gewindebohrer.

Application:

For the chucking of quick change adaptors for taps.

Application:

Pour le serrage d'adapteurs portetauds à changement rapide.

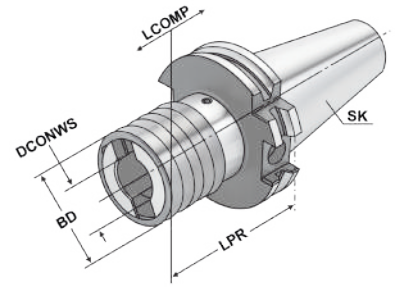

Bestell-Nr. Order no. Référence	SK	Spannbereich Capacity Capacité	SZID	DCONWS	LPR	BD	LCOMP
302.16.12	SK 30	M3 - M14	1	19	65	36	7
302.16.20	SK 30	M5 - M22	2	31	102	53	12
402.16.12	SK 40	M3 - M14	1	19	63	36	7
402.16.20	SK 40	M5 - M22	2	31	97	53	12
402.16.36	SK 40	M14 - M36	3	48	156	78	17,5
502.16.12	SK 50	M3 - M14	1	19	63	36	7
502.16.20	SK 50	M5 - M22	2	31	97	53	12
502.16.36	SK 50	M14 - M36	3	48	140	78	17,5

Hinweis:

Note:

Remarque:

Für Bearbeitungszentren ohne Synchronspindel.
For machining centres without synchronous spindle.
Pour centres d'usinage sans broche synchrone.



ohne Längenausgleich auf Druck und Zug

[DIN 69871]

Quick change tapping chucks **without** length compensation on compression and expansion

Mandrins de taraudage à changement rapide **sans** compensation longitudinale à la compression et traction



Verwendung:
Zur Aufnahme von Schnellwechsel-Einsätzen für Gewindebohrer.

Application:
For the chucking of quick change adaptors for taps.

Application:
Pour le serrage d'adapteurs portetarauds à changement rapide.

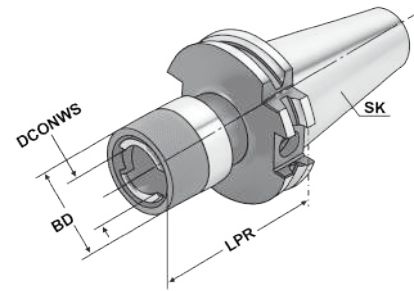

ISO 7388-1 Form AD RFID Chip

13.04

Bestell-Nr. Order no. Référence	SK	Spannbereich Capacity Capacité	SZID	DCONWS	LPR	BD
302.16.12.1	SK 30	M3 – M14	1	19	58	34
302.16.20.1	SK 30	M5 – M22	2	31	103	49
402.16.12.1	SK 40	M3 – M14	1	19	62	34
402.16.20.1	SK 40	M5 – M22	2	31	95	49
402.16.36.1	SK 40	M14 – M36	3	48	130	74
502.16.12.1	SK 50	M3 – M14	1	19	60	34
502.16.20.1	SK 50	M5 – M22	2	31	85	49
502.16.36.1	SK 50	M14 – M36	3	48	117	74

Hinweis: Für Bearbeitungszentren mit Synchronspindel.
Note: For machining centres with synchronous spindle.
Remarque: Pour centres d'usinage avec broche synchrone.

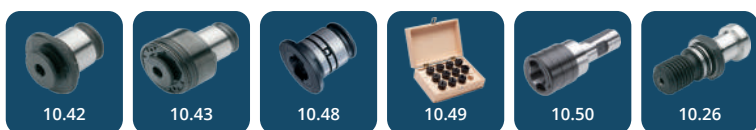



Tapping chucks for synchronisation for collets DIN 6499 (ISO 15488) ER-system

Mandrins de taraudage pour synchronisation pour pinces DIN 6499 (ISO 15488) système ER

1



Verwendung:

Für Bearbeitungszentren mit Synchronspindel.

Application:

For machining centres with synchronous spindle.

Application:

Pour centres d'usinage avec la broche synchrone.

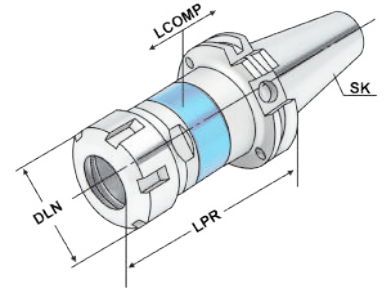

Bestell-Nr. Order no. Référence	SK	DCONWS Spannbereich Capacity Capacité	Typ	LPR	DLN	LCOMP
403.16.02.10 ¹	SK 40	M3 – M12	426E ER 16 SW25	79	28	0,5
403.16.02.10.M ²	SK 40	M3 – M12	426E ER 16 Mini	79	22	0,5
403.16.02.13	SK 40	M3 – M16	428E ER 20	80	34	0,5
403.16.02.16	SK 40	M3 – M20	430E ER 25	84	42	0,5
403.16.02.20	SK 40	M3 – M27	470E ER 32	95	50	0,5
403.16.02.26	SK 40	M3 – M33	472E ER 40	120	63	0,5
503.16.02.10 ¹	SK 50	M3 – M12	426E ER 16 SW25	79	28	0,5
503.16.02.10.M ²	SK 50	M3 – M12	426E ER 16 Mini	79	22	0,5
503.16.02.10.1.M ²	SK 50	M3 – M12	426E ER 16 Mini	90	22	0,5
503.16.02.13	SK 50	M3 – M16	428E ER 20	80	34	0,5
503.16.02.16	SK 50	M3 – M20	430E ER 25	84	42	0,5
503.16.02.20	SK 50	M3 – M27	470E ER 32	95	50	0,5
503.16.02.26	SK 50	M3 – M33	472E ER 40	105	63	0,5

¹ Sechskantmutter

¹ Hexagonal clamping nut

¹ Écrous hexagonal

² Minimutter

² Mini nut

² Écrous mini

Hinweis:

- Synchro-Gewindeschneidfutter kompensieren Synchronisationsfehler.
- Minimallängenausgleich in Druck- und Zugrichtung zwischen Synchronspindel und Gewindebohrer reduziert zu hohe Gewindeflankenreibungskräfte.
- Reduziert eventuelle Axialkraftherhöhung während des Schneidzyklus auf ein Minimum.
- Geeignet für Innenkühlung.
- Kühlmitteldruck max. 100 bar.

Note:

- Synchro tapping chucks compensate synchronisation errors.
- Minimal length compensation on compression and expansion balances very small pitch differences between synchro spindle and tap, which can cause high frictional forces on the thread flanks.
- A possible increase of axial force during the tapping process is reduced to a minimum.
- Suitable for internal coolant.
- Coolant pressure up to max. 100 bar.

Remarque:

- Les mandrins de taraudage synchro corrigent les erreurs commises lors de la synchronisation.
- La compensation de longueur minimale vers la compression et la traction entre la broche synchrone et le taraud réduit les forces de frottement qui sont trop élevées sur les flancs du filet.
- Réduit à min. l'augmentation potentielle de la force axiale pendant le coupage.
- Convient pour le refroidissement interne.
- La pression du liquide d'arrosage max. 100 bar.

Lieferumfang:

Mit gewichteter Spannmutter

Delivery:

With balanced clamping nut

Livraison:

Avec écrou de serrage équilibré

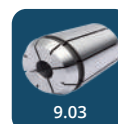

9.03



10.24



10.51



10.26

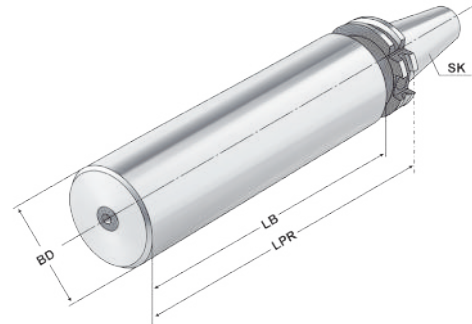

Verwendung:
Zur Herstellung von Sonderwerkzeugen.
Application:
For the manufacturing of special tools.
Application:
Pour la fabrication d'outils spéciaux.

ISO
7388-1Form
ARFID
ChipBestell-Nr.
Order no.
Référence

SK

BD

LB

LPR

302.17.40

SK 30

40,5

-

160

402.17.63

SK 40

63

215

250

502.17.97

SK 50

97

280

315

Ausführung:
Version:
Version:

Steilkegel und Bund gehärtet und geschliffen. Schaft weich zur weiteren Bearbeitung.
Cone and flange hardened and grinded. Soft body for later processing.
Cône et collerette durcis et rectifiés. Corps doux pour un usinage ultérieur.

Gewuchtete Ausführung

Balanced type
Type équilibré



Bestell-Nr.
Order no.
Référence

Abmessung
Size
Dimension

Wuchten auf G 2,5 von vorgewuchteten Kemmler-Werkzeugen

Balancing at G 2.5 of pre-balanced Kemmler-tools
Équilibrage G 2,5 d'outils Kemmler pré-équilibrés

W25

Ohne Wuchtprotokoll

Without balancing report
Sans protocole d'équilibrage

W25.2

Mit Wuchtprotokoll

With balancing report
Avec protocole d'équilibrage

Wuchten von nicht vorgewuchteten Werkzeugen
Balancing of unbalanced tools
Équilibrage d'outils non-équilibrés

W25.1

Ohne Wuchtprotokoll

Without balancing report
Sans protocole d'équilibrage



10.26

1



Verwendung:

Zur Abnahme von Werkzeugmaschinen gemäß ISO-Empfehlung R230 oder zur Überprüfung der Werkzeugspindel.

Application:

For the inspection of machine tools according to ISO recommendation R230 or for testing the tool spindle.

Application:

Pour l'inspection de machine-outils suite à la recommandation ISO R230 ou pour la vérification de la broche.

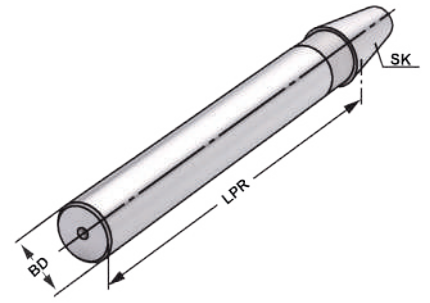

Bestell-Nr. Order no. Référence	SK	LPR	BD	Toleranz Tolerance Tolérance	max. Rundlaufabweichung max. concentricity deviation Faux-rond max.
302.18.32	SK 30	300	32	0,003	0,003
402.18.40	SK 40	300	40	0,003	0,003
502.18.50	SK 50	300	50	0,003	0,003

Lieferumfang: Auslieferung mit Prüfprotokoll
Delivery: Delivery with test certificate
Livraison: Livraison avec rapport d'essais

Holzkasten für Kontrolldorne

Wooden box for test arbors
Coffret en bois pour mandrins de contrôle



Verwendung:

Zur Aufbewahrung von Kontrolldornen.

Application:

For the storage of test arbors.

Application:

Pour la conservation de mandrins de contrôle.



Bestell-Nr. Order no. Référence	Abmessung Size Dimension	für Kegelgrößen for cones pour cônes
701.18	460 × 130 × 115	SK 30 / 40 / 50





Verwendung:
Zur Aufnahme von Werkzeugen mit Zylinderschaft nach DIN 1835 Form A+B+E und DIN 6535 Form HB+HE (größer Ø 20 mm nur mit Reduzierung).

Application:
For mounting straight-shank tools acc. DIN 1835 form A+B+E and DIN 6535 form HB+HE (larger than Ø 20 mm only with reduction sleeve).

Application:
Pour le serrage d'outils à queue cylindrique selon DIN 1835 forme A+B+E et DIN 6535 forme HB+HE (à partir de Ø 20 mm seulement avec réduction).

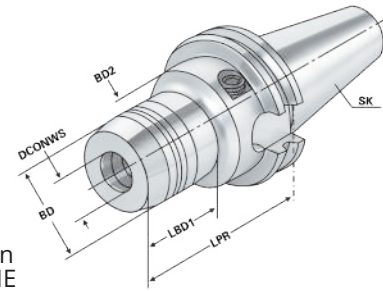

ISO 7388-1 Form AD $\leq 3\mu\text{m}$ G2.5 25.000 min⁻¹ RFID Chip

13.04

Bestell-Nr. Order no. Référence	SK	DCONWS	LPR	BD	BD2	LSCX	ADJRGA	LBD1	DRVS	THID
302.H06	SK 30	6	60	26	45	37	10	25	5	M6x1
302.H08	SK 30	8	64	28	45	37	10	29	5	M6x1
302.H10	SK 30	10	64	30	45	42	10	35	5	M6x1
302.H12	SK 30	12	72	32	45	47	10	43	5	M8x1
302.H14	SK 30	14	72	34	45	47	10	42	5	M10x1
302.H16	SK 30	16	72	38	45	52	10	43	5	M12x1
302.H18	SK 30	18	72	40	45	52	10	42	5	M12x1
302.H20	SK 30	20	90	42	42	52	10	71	5	M12x1

LSCX = Einspannlänge, max. ADJRGA = Verstellweg, max.
LSCX = Clamping depth, max. ADJRGA = Length adjustment range, max.
LSCX = Profondeur d'insertion, max. ADJRGA = Course de réglage, max.

Lieferumfang: Ohne Spannschlüssel
Delivery: Without wrench
Livraison: Sans clé de serrage



Spannkraft-Prüfgerät für Hydrodehnspannfutter - Seite 12.59
Clamping force proofing instrument for hydraulic chucks - page 12.59
Appareil de contrôle des forces de serrage pour mandrin expansibles hydrauliques - page 12.59



9.89 9.90 9.92 12.59 10.26 10.22



1



Verwendung:
Zur Aufnahme von Werkzeugen mit Zylinderschaft nach DIN 1835 Form A+B+E und DIN 6535 Form HB+HE (größer Ø 20 mm nur mit Reduzierung).

Application:
For mounting straight-shank tools acc. DIN 1835 form A+B+E and DIN 6535 form HB+HE (larger than Ø 20 mm only with reduction sleeve).

Application:
Pour le serrage d'outils à queue cylindrique selon DIN 1835 forme A+B+E et DIN 6535 forme HB+HE (à partir de Ø 20 mm seulement avec réduction).

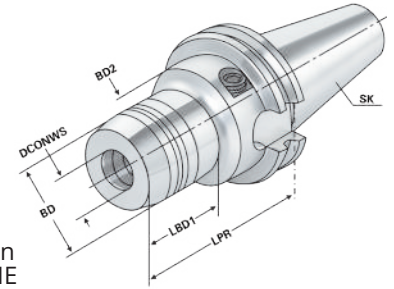

Bestell-Nr. Order no. Référence	SK	DCONWS	LPR	BD	BD2	LSCX	ADJRGA	LBD1	DRVS	THID
403.H06	SK 40	6	68	26	50	37	10	33	5	M6x1
403.H08	SK 40	8	68	28	50	37	10	33	5	M6x1
403.H10	SK 40	10	72	30	50	42	10	37	5	M8x1
403.H12	SK 40	12	77	32	50	47	10	42	5	M8x1
403.H14	SK 40	14	77	34	50	47	10	42	5	M10x1
403.H16	SK 40	16	80	38	50	52	10	43	5	M10x1
403.H18	SK 40	18	80	40	50	52	10	43	5	M10x1
403.H20	SK 40	20	82	42	50	52	10	47	5	M10x1
403.H25	SK 40	25	117	50	63	58	10	51	6	M12x1
403.H32	SK 40	32	117	60	63	64	10	51	6	M12x1
403.H06.1	SK 40	6	110	26	50	37	10	33	5	M6x1
403.H08.1	SK 40	8	110	28	50	37	10	33	5	M6x1
403.H10.1	SK 40	10	110	30	50	42	10	37	5	M8x1
403.H12.1	SK 40	12	110	32	50	47	10	42	5	M8x1
403.H14.1	SK 40	14	110	34	50	47	10	42	5	M10x1
403.H16.1	SK 40	16	110	38	50	52	10	43	5	M10x1
403.H18.1	SK 40	18	110	40	50	52	10	43	5	M12x1
403.H20.1	SK 40	20	110	42	50	52	10	47	5	M12x1
403.H06.2	SK 40	6	150	26	50	42	10	110	5	M6x1
403.H08.2	SK 40	8	150	28	50	42	10	110	5	M6x1
403.H10.2	SK 40	10	150	30	50	42	10	110	5	M8x1
403.H12.2	SK 40	12	150	32	50	47	10	110	5	M8x1
403.H14.2	SK 40	14	150	34	50	47	10	110	5	M10x1
403.H16.2	SK 40	16	150	38	50	52	10	110	5	M10x1
403.H18.2	SK 40	18	150	40	50	52	10	110	5	M12x1
403.H20.2	SK 40	20	150	42	50	52	10	110	5	M12x1
403.H25.2	SK 40	25	150	50	63	58	10	94	6	M12x1

LSCX = Einspannlänge, max.
LSCX = Clamping depth, max.
LSCX = Profondeur d'insertion, max.

ADJRGA = Verstellweg, max.
ADJRGA = Length adjustment range, max.
ADJRGA = Course de réglage, max.

Lieferumfang: Ohne Spannschlüssel
Delivery: Without wrench
Livraison: Sans clé de serrage

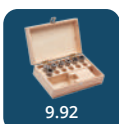



Verwendung:
Zur Aufnahme von Werkzeugen mit Zylinderschaft nach DIN 1835 Form A+B+E und DIN 6535 Form HB+HE (größer Ø 20 mm nur mit Reduzierung).

Application:
For mounting straight-shank tools acc. DIN 1835 form A+B+E and DIN 6535 form HB+HE (larger than Ø 20 mm only with reduction sleeve).

Application:
Pour le serrage d'outils à queue cylindrique selon DIN 1835 forme A+B+E et DIN 6535 forme HB+HE (à partir de Ø 20 mm seulement avec réduction).

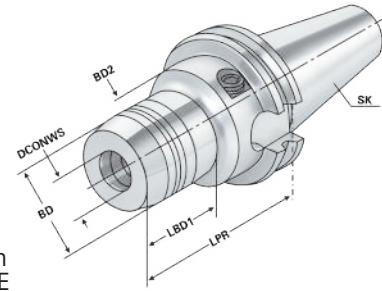

ISO 7388-1 Form AD/AF (AD/B) ≤ 3µm G2.5 25.000 min⁻¹ RFID Chip

13.04

Bestell-Nr. Order no. Référence	SK	DCONWS	LPR	BD	BD2	LSCX	ADJRGA	LBD1	DRVS	THID
503.H06	SK 50	6	68	26	50	37	10	33	5	M6x1
503.H08	SK 50	8	68	28	50	37	10	33	5	M6x1
503.H10	SK 50	10	72	30	50	42	10	37	5	M8x1
503.H12	SK 50	12	77	32	50	47	10	42	5	M8x1
503.H14	SK 50	14	77	34	50	47	10	42	5	M10x1
503.H16	SK 50	16	80	38	50	52	10	45	5	M12x1
503.H18	SK 50	18	80	40	50	52	10	45	5	M12x1
503.H20	SK 50	20	82	42	50	52	10	47	5	M12x1
503.H25	SK 50	25	87	50	63	58	10	52	6	M12x1
503.H32	SK 50	32	91	60	63	64	10	56	6	M12x1
503.H06.1	SK 50	6	110	26	50	37	10	33	5	M6x1
503.H08.1	SK 50	8	110	28	50	37	10	33	5	M6x1
503.H10.1	SK 50	10	110	30	50	42	10	37	5	M8x1
503.H12.1	SK 50	12	110	32	50	47	10	42	5	M8x1
503.H14.1	SK 50	14	110	34	50	47	10	42	5	M10x1
503.H16.1	SK 50	16	110	38	50	52	10	45	5	M12x1
503.H18.1	SK 50	18	110	40	50	52	10	45	5	M12x1
503.H20.1	SK 50	20	110	42	50	52	10	47	5	M12x1
503.H25.1	SK 50	25	110	50	63	58	10	52	6	M16x1
503.H32.1	SK 50	32	110	60	63	64	10	56	6	M16x1
503.H06.2	SK 50	6	150	26	50	37	10	110	5	M6x1
503.H08.2	SK 50	8	150	28	50	37	10	110	5	M6x1
503.H10.2	SK 50	10	150	30	50	42	10	110	5	M8x1
503.H12.2	SK 50	12	150	32	50	47	10	110	5	M8x1
503.H14.2	SK 50	14	150	34	50	47	10	110	5	M10x1
503.H16.2	SK 50	16	150	38	50	52	10	110	5	M12x1
503.H18.2	SK 50	18	150	40	50	52	10	110	5	M12x1
503.H20.2	SK 50	20	150	42	50	52	10	110	5	M12x1
503.H25.2	SK 50	25	150	50	50	52	10	110	6	M16x1
503.H32.2	SK 50	32	150	60	63	64	10	110	6	M16x1
503.H40.2	SK 50	40	150	63	63	74	10	131	6	M16x1

LSCX = Einspannlänge, max. ADJRGA = Verstellweg, max.
LSCX = Clamping depth, max. ADJRGA = Length adjustment range, max.
LSCX = Profondeur d'insertion, max. ADJRGA = Course de réglage, max.

Lieferumfang: Ohne Spannschlüssel
Delivery: Without wrench
Livraison: Sans clé de serrage



1



Verwendung:
Zur Aufnahme von Werkzeugen mit Zylinderschaft. Besonders im Werkzeug- und Formenbau wo reduzierte Störkontur gefordert ist.

Application:
For mounting straight-shank tools. Especially in operations in toolmaking and mould making. Wherever reduced interference contours are required.

Application:
Pour le serrage d'outils avec queue cylindrique. Particulièrement dans la fabrication d'outils et de moules. Applications nécessitant un encombrement réduit.

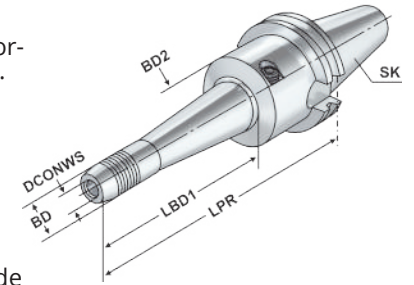

ISO 7388-1 Form AD/AF (AD/B) $\leq 3\mu\text{m}$ G7.5 25.000 min⁻¹ RFID Chip

13.04

Bestell-Nr. Order no. Référence	SK	DCONWS	LPR	BD	BD2	LSCX	ADJRGA	LBD1	DRVS	THID
403.HSL06.160	SK 40	6	160	16	50	37	10	103	5	M6x1
403.HSL08.160	SK 40	8	160	18	50	37	10	103	5	M6x1
403.HSL10.160	SK 40	10	160	20	50	42	10	103	5	M8x1
403.HSL12.160	SK 40	12	160	22	50	47	10	103	5	M8x1

LSCX = Einspannlänge, max. ADJRGA = Verstellweg, max.
LSCX = Clamping depth, max. ADJRGA = Length adjustment range, max.
LSCX = Profondeur d'insertion, max. ADJRGA = Course de réglage, max.

Lieferumfang: Ohne Spannschlüssel
Delivery: Without wrench
Livraison: Sans clé de serrage



Spannkraft-Prüfgerät für Hydrodehnspannfutter - Seite 12.59
Clamping force proofing instrument for hydraulic chucks - page 12.59
Appareil de contrôle des forces de serrage pour mandrin expansibles hydrauliques - page 12.59



9.89 9.90 9.92 12.59 10.26 10.22

Reparatur und Wartung für Hydro-Dehnspannfutter

Die Hydro-Dehnspanntechnik ist eine weltweit verbreitete, bewährte und zuverlässige Methode zur Aufnahme von Werkzeugen. Dank ihrer konstruktiven Vorteile ist sie unempfindlich, wartungsarm und langlebig. Dennoch kommt es durch thermische und mechanische Belastung im Werkstattgebrauch im Laufe der Zeit zu Spannkraftverlusten. Die Folge sind schlechtere Werkzeugstandzeiten und Qualitätseinbußen bei der Bearbeitung bis hin zum teuren Werkzeugbruch.

Wir warten und reparieren Ihre Hydro-Dehnspannfutter - egal ob von uns oder ein Fremdfabrikat - kostengünstig hier bei uns in Süd-Deutschland.

Hier prüfen wir die Ursachen für den Spannkraftverlust und reparieren innerhalb von zwei Wochen zu einem günstigen Festpreis. Wir erneuern dabei alle Verschleißteile, befüllen das Hydrauliksystem neu und justieren das Hydrauliksystem auf den korrekten Spanndruck. Abschließend erfolgt eine Endprüfung.

Kontaktieren Sie unseren Kundenservice für weitere Informationen und Preise.

Maintenance and repair of hydraulic chucks

Clamping of tools with hydraulic chucks is a widespread, well-established and reliable method.

It is a resistant, easy-to-operate and durable way of clamping due to its advantageous construction design.

Nevertheless in the course of time under the influence of thermal and mechanical outputs at factories loss of clamping force is observed. As a result the life of the tool shortens and its quality during the working process reduces. Therefore it leads to a costly damage of the tool.

We maintain and repair your hydraulic chucks - both those manufactured at our place and those produced somewhere else - for a reasonable price here at our office in the south of Germany.

We check possible causes of the clamping force reduction and repair it within two weeks at a fixed low price. At the same time we renew all the fast wearing parts, fill the hydraulic system anew and adjust its clamping force. Afterwards the final inspection stage takes place.

You are welcome to contact our customer service for further information and prices.

La réparation et la maintenance des mandrins hydrauliques

L'accueil des outils à l'aide d'un mandrin hydraulique est une technique éprouvée, répandue à l'échelle mondiale et de confiance.

Grâce à sa construction avantageuse elle est robuste, facile à entretenir et durable.

Pourtant à cause de la charge thermique et mécanique imposés sur les mandrins lors du travail la tension du ressort diminue au fil du temps. Par conséquent la résistance des outils coupants se détériore et la qualité lors d'usinage se réduit. En retour cela conduit à la rupture coûteuse d'outil.

On entretient et répare vos mandrins hydrauliques - peu importe l'issu de notre production ou d'ailleurs - bon marché et ici chez nous au sud de l'Allemagne.

Tout d'abord nos spécialistes cherchent la cause de la perte de la tension du ressort, ensuite ils effectuent la réparation sous 2 semaines pour le prix fixe et favorable. En outre ils renouvellent toutes les pièces d'usure, remplissent le système hydraulique à nouveau et ajustent la tension correcte. À la fin l'inspection finale se déroule.

Contactez notre centre de service client pour obtenir l'information supplémentaire ainsi que l'information actuelle sur le prix.



1



Verwendung:
Zur Aufnahme von Werkzeugen mit Zylinderschaft.

Application:
For mounting straight-shank tools.

Application:
Pour le serrage d'outil à queue cylindrique.

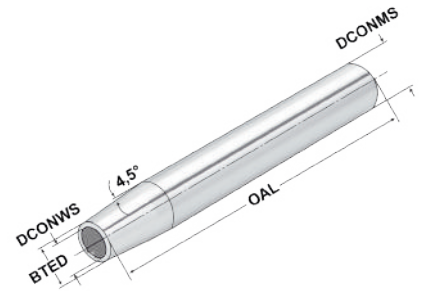

Bestell-Nr. Order no. Référence	DCONMS	DCONWS	BTED	OAL	LSCN	LSCX	ADJRGA	THID
120.70.03	20	3	10	150	6	-	-	-
120.70.04	20	4	10	150	8	-	-	-
120.70.05	20	5	10	150	10	-	-	-
120.70.06*	20	6	10	150	22	36	10	M5x0,8
120.70.08*	20	8	12	150	26	36	10	M6x1
120.70.10*	20	10	14	150	31	41	10	M8x1
120.70.12*	20	12	16	150	36	46	10	M10x1

* mit Anschlag | * with end stop | * avec butée

Durchgangsbohrung für Innenkühlung vorhanden.
Through hole for internal cooling provided.
Trou débouchant disponible pour arrosage interne.

LSCX = Einspannlänge, max. ADJRGA = Verstellweg, max.
LSCX = Clamping depth, max. ADJRGA = Length adjustment range, max.
LSCX = Profondeur d'insertion, max. ADJRGA = Course de réglage, max.

Für Ø 3, 4 und 5 mm nur Hartmetallschäfte verwenden!
For Ø 3, 4 and 5 mm only solid carbide tool shanks must be used!
Pour Ø 3, 4 et 5 mm il faut seulement utiliser de queues d'outils carbures de type HM!

Hinweis: Aufnahmen für Induktiv-, Kontakt- und Heißluftschumpfergeräte geeignet.
Schafttoleranz bei Ø 3, 4 und 5 mm = h₄, bei Ø 6 – Ø 32 mm = h₆

Note: Toolholders suitable for induction-, contact- and hot air shrink units.
Ø 3, 4, 5 with h₄-tolerance and Ø 6 – Ø 32 with h₆-tolerance

Remarque: Porte-outils convenables pour machines à fretter par induction, par contact, ou par air chaud.
Ø 3, 4, 5 avec h₄-tolerance et Ø 6 – Ø 32 avec h₆-tolerance

Shrink chucks 4,5° for mounting of solid carbide and HSS-tool shanks

Mandrins de frettage 4,5° pour le serrage de queues d'outils en carbure du type HM et HSS



Verwendung:
Zur Aufnahme von Werkzeugen mit Zylinderschaft.

Application:
For mounting straight-shank tools.

Application:
Pour le serrage d'outil à queue cylindrique.

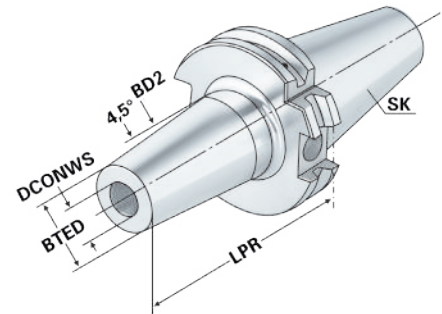

ISO 7388-1 Form AD $\leq 3\mu\text{m}$ G2.5 25.000 min⁻¹ RFID Chip h6

Bestell-Nr. Order no. Référence	SK	DCONWS	TDCON	LPR	BTED	BD2	LSCN	LSCX	ADJRGA	THID
302.70.03	SK 30	3	h4	80	15	20	6	-	-	-
302.70.04	SK 30	4	h4	80	15	20	8	-	-	-
302.70.05	SK 30	5	h4	80	15	20	10	-	-	-
302.70.06	SK 30	6	h6	80	21	27	22	36	10	M5x0,8
302.70.08	SK 30	8	h6	80	21	27	26	36	10	M6x1
302.70.10	SK 30	10	h6	80	24	32	31	41	10	M8x1
302.70.12	SK 30	12	h6	100	24	32	36	46	10	M10x1
302.70.14	SK 30	14	h6	100	27	34	36	46	10	M10x1
302.70.16	SK 30	16	h6	100	27	34	39	49	10	M12x1
302.70.18	SK 30	18	h6	100	33	42	39	49	10	M12x1
302.70.20	SK 30	20	h6	100	33	42	41	51	10	M16x1

LSCX = Einspannlänge, max.
LSCX = Clamping depth, max.
LSCX = Profondeur d'insertion, max.

ADJRGA = Verstellweg, max.
ADJRGA = Length adjustment range, max.
ADJRGA = Course de réglage, max.

Für Ø 3, 4 und 5 mm nur Hartmetallschäfte verwenden

For Ø 3, 4 and 5 mm only solid carbide tool shanks must be used
Pour Ø 3, 4 et 5 mm il faut seulement utiliser de queues d'outils carbures de type HM

Hinweis: Aufnahmen für Induktiv-, Kontakt- und Heißluftschumpfgeräte geeignet.
Schafftoleranz bei Ø 3, 4 und 5 mm = h4, bei Ø 6 - Ø 32 mm = h6

Note: Toolholders suitable for induction-, contact- and hot air shrink units.
Ø 3, 4, 5 with h4-tolerance and Ø 6 - Ø 32 with h6-tolerance

Remarque: Porte-outils convenables pour machines à fretter par induction, par contact, ou par air chaud.
Ø 3, 4, 5 avec h4-tolerance et Ø 6 - Ø 32 avec h6-tolerance



Nachträgliches Erodieren von 2 Kühlkanalbohrungen

Supplementary eroding of 2 cooling channels

Erodage complémentaire de 2 trous de canaux de refroidissement

Bestell-Nr.
Order no.
Référence

U.KKB





Shrink chucks 4,5° for mounting of solid carbide and HSS-tool shanks

Mandrins de frettage 4,5° pour le serrage de queues d'outils en carbure du type HM et HSS

1



Verwendung:
Zur Aufnahme von Werkzeugen mit Zylinderschaft.

Application:
For mounting straight-shank tools.

Application:
Pour le serrage d'outil à queue cylindrique.

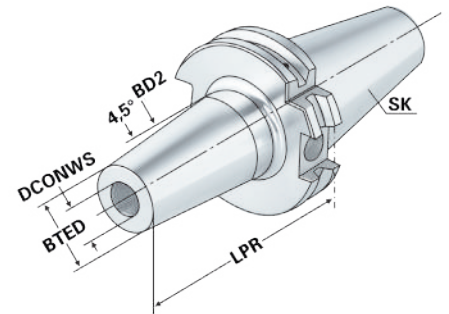

- ISO 7388-1
- Form AD/AF (AD/B)
- ≤ 3µm
- G7.5 25.000 min⁻¹
- RFID Chip
- h6

Bestell-Nr. Order no. Référence	SK	DCONWS	TDCON	LPR	BTED	BD2	LSCN	LSCX	ADJRGA	THID
403.70.03	SK 40	3	h4	80	15	20	6	-	-	-
403.70.04	SK 40	4	h4	80	15	20	8	-	-	-
403.70.05	SK 40	5	h4	80	15	20	10	-	-	-
403.70.06	SK 40	6	h6	80	21	27	22	36	10	M5x0,8
403.70.08	SK 40	8	h6	80	21	27	26	36	10	M6x1
403.70.10	SK 40	10	h6	80	24	32	31	41	10	M8x1
403.70.12	SK 40	12	h6	80	24	32	36	46	10	M10x1
403.70.14	SK 40	14	h6	80	27	34	36	46	10	M10x1
403.70.16	SK 40	16	h6	80	27	34	39	49	10	M12x1
403.70.18	SK 40	18	h6	80	33	42	39	49	10	M12x1
403.70.20	SK 40	20	h6	80	33	42	41	51	10	M16x1
403.70.25	SK 40	25	h6	100	44	53	47	57	10	M16x1
403.70.32	SK 40	32	h6	100	44	53	51	61	10	M16x1
403.70.03.1	SK 40	3	h4	120	15	20	6	-	-	-
403.70.04.1	SK 40	4	h4	120	15	20	8	-	-	-
403.70.05.1	SK 40	5	h4	120	15	20	10	-	-	-
403.70.06.1	SK 40	6	h6	120	21	27	22	36	10	M5x0,8
403.70.08.1	SK 40	8	h6	120	21	27	26	36	10	M6x1
403.70.10.1	SK 40	10	h6	120	24	32	31	41	10	M8x1
403.70.12.1	SK 40	12	h6	120	24	32	36	46	10	M10x1
403.70.14.1	SK 40	14	h6	120	27	34	36	46	10	M10x1
403.70.16.1	SK 40	16	h6	120	27	34	39	49	10	M12x1
403.70.18.1	SK 40	18	h6	120	33	42	39	49	10	M12x1
403.70.20.1	SK 40	20	h6	120	33	42	41	51	10	M16x1

LSCX = Einspannlänge, max. ADJRGA = Verstellweg, max.
 LSCX = Clamping depth, max. ADJRGA = Length adjustment range, max.
 LSCX = Profondeur d'insertion, max. ADJRGA = Course de réglage, max.

Für Ø 3, 4 und 5 mm nur Hartmetallschäfte verwenden
For Ø 3, 4 and 5 mm only solid carbide tool shanks must be used
 Pour Ø 3, 4 et 5 mm il faut seulement utiliser de queues d'outils carbures de type HM

Hinweis: Aufnahmen für Induktiv-, Kontakt- und Heißluftschumpfgeräte geeignet.
 Schafttoleranz bei Ø 3, 4 und 5 mm = h4, bei Ø 6 - Ø 32 mm = h6

Note: Toolholders suitable for induction-, contact- and hot air shrink units.
 Ø 3, 4, 5 with h4-tolerance and Ø 6 - Ø 32 with h6-tolerance

Remarque: Porte-outils convenables pour machines à fretter par induction,
 par contact, ou par air chaud.
 Ø 3, 4, 5 avec h4-tolerance et Ø 6 - Ø 32 avec h6-tolerance



Shrink chucks 4,5° for mounting of solid carbide and HSS-tool shanks

Mandrins de frettage 4,5° pour le serrage de queues d'outils en carbure du type HM et HSS



Verwendung:
Zur Aufnahme von Werkzeugen mit Zylinderschaft.

Application:
For mounting straight-shank tools.

Application:
Pour le serrage d'outils à queue cylindrique.

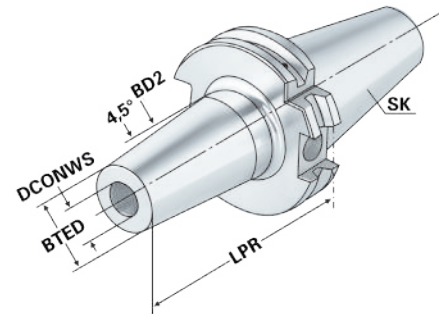

ISO
7388-1

Form
AD/AF
(AD/B)

$\leq 3\mu\text{m}$

$G2.5$
 25.000
 min^{-1}

RFID
Chip

h6

Bestell-Nr. Order no. Référence	SK	DCONWS	TDCON	LPR	BTED	BD2	LSCN	LSCX	ADJRGA	THID
403.70.03.2	SK 40	3	h4	160	15	20	6	-	-	-
403.70.04.2	SK 40	4	h4	160	15	20	8	-	-	-
403.70.05.2	SK 40	5	h4	160	15	20	10	-	-	-
403.70.06.2	SK 40	6	h6	160	21	27	22	36	10	M5x0,8
403.70.08.2	SK 40	8	h6	160	21	27	26	36	10	M6x1
403.70.10.2	SK 40	10	h6	160	24	32	31	41	10	M8x1
403.70.12.2	SK 40	12	h6	160	24	32	36	46	10	M10x1
403.70.14.2	SK 40	14	h6	160	27	34	36	46	10	M10x1
403.70.16.2	SK 40	16	h6	160	27	34	39	49	10	M12x1
403.70.18.2	SK 40	18	h6	160	33	42	39	49	10	M12x1
403.70.20.2	SK 40	20	h6	160	33	42	41	51	10	M16x1
403.70.25.2	SK 40	25	h6	160	44	53	47	57	10	M16x1
403.70.32.2	SK 40	32	h6	160	44	53	51	61	10	M16x1

LSCX = Einspannlänge, max. ADJRGA = Verstellweg, max.
 LSCX = Clamping depth, max. ADJRGA = Length adjustment range, max.
 LSCX = Profondeur d'insertion, max. ADJRGA = Course de réglage, max.

Für Ø 3, 4 und 5 mm nur Hartmetallschäfte verwenden
For Ø 3, 4 and 5 mm only solid carbide tool shanks must be used
 Pour Ø 3, 4 et 5 mm il faut seulement utiliser de queues d'outils carbures de type HM

- Hinweis:** Aufnahmen für Induktiv-, Kontakt- und Heißluftschumpfergeräte geeignet.
 Schafttoleranz bei Ø 3, 4 und 5 mm = h4, bei Ø 6 - Ø 32 mm = h6
- Note:** *Toolholders suitable for induction-, contact- and hot air shrink units.*
 Ø 3, 4, 5 with h4-tolerance and Ø 6 - Ø 32 with h6-tolerance
- Remarque:** Porte-outils convenables pour machines à fretter par induction,
 par contact, ou par air chaud.
 Ø 3, 4, 5 avec h4-tolerance et Ø 6 - Ø 32 avec h6-tolerance



Nachträgliches Erodieren von 2 Kühlkanalbohrungen
Supplementary eroding of 2 cooling channels
 Erodage complémentaire de 2 trous de canaux de refroidissement

Bestell-Nr.
Order no.
Référence

U.KKB





Shrink chucks 4,5° for mounting of solid carbide and HSS-tool shanks

Mandrins de frettage 4,5° pour le serrage de queues d'outils en carbure du type HM et HSS

1



Verwendung:
Zur Aufnahme von Werkzeugen mit Zylinderschaft.

Application:
For mounting straight-shank tools.

Application:
Pour le serrage d'outil à queue cylindrique.

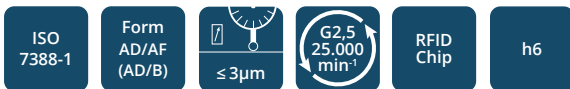
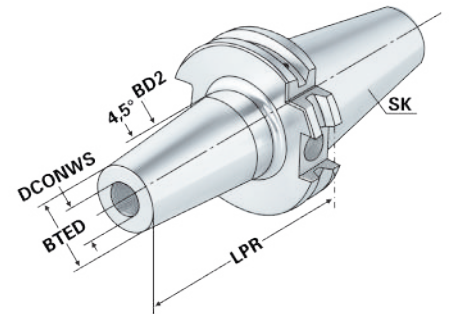

Bestell-Nr. Order no. Référence	SK	DCONWS	TDCON	LPR	BTED	BD2	LSCN	LSCX	ADJRGA	THID
503.71.03	SK 50	3	h4	80	15	20	6	-	-	-
503.71.04	SK 50	4	h4	80	15	20	8	-	-	-
503.71.05	SK 50	5	h4	80	15	20	10	-	-	-
503.71.06	SK 50	6	h6	80	21	27	22	36	10	M5x0,8
503.71.08	SK 50	8	h6	80	21	27	26	36	10	M6x1
503.71.10	SK 50	10	h6	80	24	32	31	41	10	M8x1
503.71.12	SK 50	12	h6	80	24	32	36	46	10	M10x1
503.71.14	SK 50	14	h6	80	27	34	36	46	10	M10x1
503.71.16	SK 50	16	h6	80	27	34	39	49	10	M12x1
503.71.18	SK 50	18	h6	80	33	42	39	49	10	M12x1
503.71.20	SK 50	20	h6	80	33	42	41	51	10	M16x1
503.71.25	SK 50	25	h6	100	44	53	47	57	10	M16x1
503.71.32	SK 50	32	h6	100	44	53	51	61	10	M16x1
503.71.06.1	SK 50	6	h6	120	21	27	22	36	10	M5x0,8
503.71.08.1	SK 50	8	h6	120	21	27	26	36	10	M6x1
503.71.10.1	SK 50	10	h6	120	24	32	31	41	10	M8x1
503.71.12.1	SK 50	12	h6	120	24	32	36	46	10	M10x1
503.71.14.1	SK 50	14	h6	120	27	34	36	46	10	M10x1
503.71.16.1	SK 50	16	h6	120	27	34	39	49	10	M12x1
503.71.18.1	SK 50	18	h6	120	33	42	39	49	10	M12x1
503.71.20.1	SK 50	20	h6	120	33	42	41	51	10	M16x1

LSCX = Einspannlänge, max. ADJRGA = Verstellweg, max.
 LSCX = Clamping depth, max. ADJRGA = Length adjustment range, max.
 LSCX = Profondeur d'insertion, max. ADJRGA = Course de réglage, max.

Für Ø 3, 4 und 5 mm nur Hartmetallschäfte verwenden

For Ø 3, 4 and 5 mm only solid carbide tool shanks must be used
 Pour Ø 3, 4 et 5 mm il faut seulement utiliser les queues d'outil en carbure de type HM

Hinweis: Aufnahmen für Induktiv-, Kontakt- und Heißluftschumpfergeräte geeignet.
 Schafttoleranz bei Ø 6 - Ø 32 mm = h6

Note: Toolholders suitable for induction-, contact- and hot air shrink units.
 Ø 6 - Ø 32 with h6-tolerance

Remarque: Porte-outils pour les machines à fretter par induction,
 par contact, ou par l'air chaud.
 Ø 6 - Ø 32 avec la h6-tolerance



Shrink chucks 4,5° for mounting of solid carbide and HSS-tool shanks

Mandrins de frettage 4,5° pour le serrage de queues d'outils en carbure du type HM et HSS



Verwendung:
Zur Aufnahme von Werkzeugen mit Zylinderschaft.

Application:
For mounting straight-shank tools.

Application:
Pour le serrage d'outil à queue cylindrique.

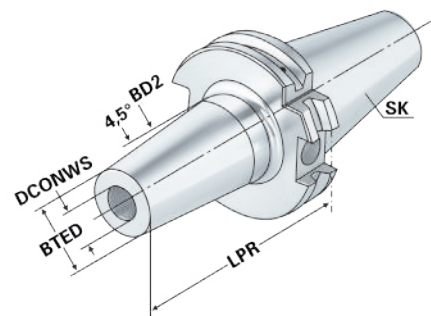

ISO 7388-1 Form AD/AF (AD/B) ≤ 3µm G2.5 25.000 min⁻¹ RFID Chip h6

Bestell-Nr. Order no. Référence	SK	DCONWS	TDCON	LPR	BTED	BD2	LSCN	LSCX	ADJRGA	THID
503.71.06.2	SK 50	6	h6	160	21	27	22	36	10	M5x0,8
503.71.08.2	SK 50	8	h6	160	21	27	26	36	10	M6x1
503.71.10.2	SK 50	10	h6	160	24	32	31	41	10	M8x1
503.71.12.2	SK 50	12	h6	160	24	32	36	46	10	M10x1
503.71.14.2	SK 50	14	h6	160	27	34	36	46	10	M10x1
503.71.16.2	SK 50	16	h6	160	27	34	39	49	10	M12x1
503.71.18.2	SK 50	18	h6	160	33	42	39	49	10	M12x1
503.71.20.2	SK 50	20	h6	160	33	42	41	51	10	M16x1
503.71.25.2	SK 50	25	h6	160	44	53	47	57	10	M16x1
503.71.32.2	SK 50	32	h6	160	44	53	51	61	10	M16x1
503.71.06.3	SK 50	6	h6	200	21	27	22	36	10	M5x0,8
503.71.08.3	SK 50	8	h6	200	21	27	26	36	10	M6x1
503.71.10.3	SK 50	10	h6	200	24	32	31	41	10	M8x1
503.71.12.3	SK 50	12	h6	200	24	32	36	46	10	M10x1
503.71.14.3	SK 50	14	h6	200	27	34	36	46	10	M10x1
503.71.16.3	SK 50	16	h6	200	27	34	39	49	10	M12x1
503.71.18.3	SK 50	18	h6	200	33	42	39	49	10	M12x1
503.71.20.3	SK 50	20	h6	200	33	42	41	51	10	M16x1
503.71.25.3	SK 50	25	h6	200	44	53	47	57	10	M16x1
503.71.32.3	SK 50	32	h6	200	44	53	51	61	10	M16x1

LSCX = Einspannlänge, max. ADJRGA = Verstellweg, max.
LSCX = Clamping depth, max. ADJRGA = Length adjustment range, max.
LSCX = Profondeur d'insertion, max. ADJRGA = Course de réglage, max.

Für Ø 3, 4 und 5 mm nur Hartmetallschäfte verwenden

For Ø 3, 4 and 5 mm only solid carbide tool shanks must be used

Pour Ø 3, 4 et 5 mm il faut seulement utiliser les queues d'outil en carbure de type HM

Hinweis: Aufnahmen für Induktiv-, Kontakt- und Heißluftschrimpferäte geeignet.
Schafttoleranz bei Ø 6 - Ø 32 mm = h6

Note: *Toolholders suitable for induction-, contact- and hot air shrink units.*
Ø 6 - Ø 32 with h6-tolerance

Remarque: Porte-outils pour les machines à frotter par induction,
par contact, ou par l'air chaud.
Ø 6 - Ø 32 avec la h6-tolerance





Shrink chucks 4,5° with coolant channels for mounting of solid carbide and HSS-tool shanks
Mandrins de frettage 4,5° avec canaux d'arrosage pour le serrage de queues d'outils en carbure du type HM et HSS

1



Verwendung:
Zur Aufnahme von Werkzeugen mit Zylinderschaft.

Application:
For mounting straight-shank tools.

Application:
Pour le serrage d'outil à queue cylindrique.

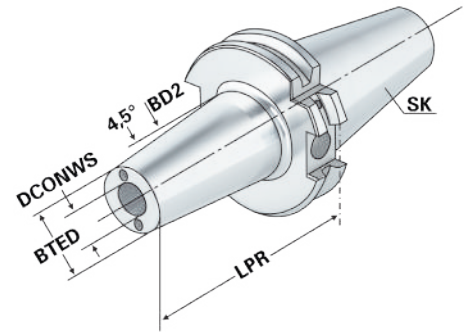

Bestell-Nr. Order no. Référence	SK	DCONWS	TDCON	LPR	BTED	BD2	LSCN	LSCX	ADJRGA	THID
403.70.06.K	SK 40	6	h6	80	21	27	22	36	10	M5x0,8
403.70.08.K	SK 40	8	h6	80	21	27	26	36	10	M6x1
403.70.10.K	SK 40	10	h6	80	24	32	31	41	10	M8x1
403.70.12.K	SK 40	12	h6	80	24	32	36	46	10	M10x1
403.70.14.K	SK 40	14	h6	80	27	34	36	46	10	M10x1
403.70.16.K	SK 40	16	h6	80	27	34	39	49	10	M12x1
403.70.18.K	SK 40	18	h6	80	33	42	39	49	10	M12x1
403.70.20.K	SK 40	20	h6	80	33	42	41	51	10	M16x1
403.70.25.K	SK 40	25	h6	100	44	53	47	57	10	M16x1
403.70.32.K	SK 40	32	h6	100	44	53	51	61	10	M16x1
403.70.06.1.K	SK 40	6	h6	120	21	27	22	36	10	M5x0,8
403.70.08.1.K	SK 40	8	h6	120	21	27	26	36	10	M6x1
403.70.10.1.K	SK 40	10	h6	120	24	32	31	41	10	M8x1
403.70.12.1.K	SK 40	12	h6	120	24	32	36	46	10	M10x1
403.70.14.1.K	SK 40	14	h6	120	27	34	36	46	10	M10x1
403.70.16.1.K	SK 40	16	h6	120	27	34	39	49	10	M12x1
403.70.18.1.K	SK 40	18	h6	120	33	42	39	49	10	M12x1
403.70.20.1.K	SK 40	20	h6	120	33	42	41	51	10	M16x1
503.71.06.K	SK 50	6	h6	80	21	27	22	36	10	M5x0,8
503.71.08.K	SK 50	8	h6	80	21	27	26	36	10	M6x1
503.71.10.K	SK 50	10	h6	80	24	32	31	41	10	M8x1
503.71.12.K	SK 50	12	h6	80	24	32	36	46	10	M10x1
503.71.14.K	SK 50	14	h6	80	27	34	36	46	10	M10x1
503.71.16.K	SK 50	16	h6	80	27	34	39	49	10	M12x1
503.71.18.K	SK 50	18	h6	80	33	42	39	49	10	M12x1
503.71.20.K	SK 50	20	h6	80	33	42	41	51	10	M16x1
503.71.25.K	SK 50	25	h6	100	44	53	47	57	10	M16x1
503.71.32.K	SK 50	32	h6	100	44	53	51	61	10	M16x1

LSCX = Einspannlänge, max.
LSCX = Clamping depth, max.
LSCX = Profondeur d'insertion, max.

ADJRGA = Verstellweg, max.
ADJRGA = Length adjustment range, max.
ADJRGA = Course de réglage, max.



Für Ø 3, 4 und 5 mm nur Hartmetallschäfte verwenden
For Ø 3, 4 and 5 mm only solid carbide tool shanks must be used
Pour Ø 3, 4 et 5 mm il faut seulement utiliser de queues d'outils en carbure du type HM

Shrink chucks 3° for mounting of solid carbide and HSS-tool shanks - slim

Mandrins de frettage 3° pour le serrage de queues d'outils en carbure du type HM et HSS - élancé



Verwendung:
Zur Aufnahme von Werkzeugen mit Zylinderschaft.

Application:
For mounting straight-shank tools.

Application:
Pour le serrage d'outil à queue cylindrique.

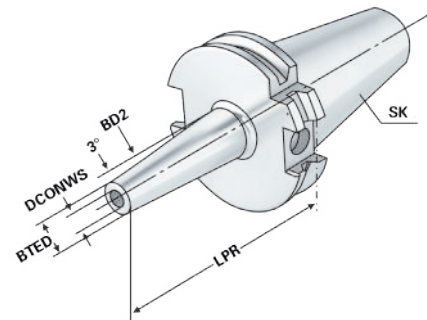

ISO 7388-1 Form AD/AF (AD/B) $\leq 3\mu\text{m}$ G2.5 25.000 min⁻¹ RFID Chip h6

Bestell-Nr. Order no. Référence	SK	DCONWS	TDCON	LPR	BTED	BD2	LSCN	LSCX	ADJRGA	THID
403.72.03	SK 40	3	h4	80	9	15,5	6	-	-	-
403.72.04	SK 40	4	h4	80	10	16,5	8	-	-	-
403.72.05	SK 40	5	h4	80	11	17,5	10	-	-	-
403.72.06	SK 40	6	h6	80	12	18,5	22	36	10	M5x0,8
403.72.08	SK 40	8	h6	80	14	20,5	26	36	10	M6x1
403.72.10	SK 40	10	h6	80	16	22,5	31	41	10	M8x1
403.72.12	SK 40	12	h6	80	18	24,5	36	46	10	M10x1
403.72.03.1	SK 40	3	h4	120	9	19,5	6	-	-	-
403.72.04.1	SK 40	4	h4	120	10	20,5	8	-	-	-
403.72.05.1	SK 40	5	h4	120	11	21,5	10	-	-	-
403.72.06.1	SK 40	6	h6	120	12	22,5	22	36	10	M5x0,8
403.72.08.1	SK 40	8	h6	120	14	24,5	26	36	10	M6x1
403.72.10.1	SK 40	10	h6	120	16	26,5	31	41	10	M8x1
403.72.12.1	SK 40	12	h6	120	18	28,5	36	46	10	M10x1
403.72.06.2	SK 40	6	h6	160	12	26,5	22	36	10	M5x0,8
403.72.08.2	SK 40	8	h6	160	14	28,5	26	36	10	M6x1
403.72.10.2	SK 40	10	h6	160	16	30,5	31	41	10	M8x1
403.72.12.2	SK 40	12	h6	160	18	32,5	36	46	10	M10x1

LSCX = Einspannlänge, max. ADJRGA = Verstellweg, max.
 LSCX = Clamping depth, max. ADJRGA = Length adjustment range, max.
 LSCX = Profondeur d'insertion, max. ADJRGA = Course de réglage, max.

Ausführung: schlanke Bauform (reduzierte Störkontur)
Version: slim design (reduced interference contour)
Version: Modèle très étroit (encombrement réduit)

Für Ø 3, 4 und 5 mm nur Hartmetallschäfte verwenden
For Ø 3, 4 and 5 mm only solid carbide tool shanks must be used
 Pour Ø 3, 4 et 5 mm il faut seulement utiliser de queues d'outils en carbure du type HM

Hinweis: Aufnahmen für Induktiv-, Kontakt- und Heißluftschrimpfergeräte geeignet.
 Schafttoleranz bei Ø 3, 4 und 5 mm = h4, bei Ø 6 - Ø 12 mm = h6

Note: Toolholders suitable for induction-, contact- and hot air shrink units.
 Ø 3, 4, 5 with h4-tolerance and Ø 6 - Ø 12 with h6-tolerance

Remarque: Porte-outils pour machines à fretter par induction,
 par contact, ou par air chaud.
 Ø 3, 4, 5 avec la h4-tolerance et Ø 6 - Ø 12 avec la h6-tolerance



WERKZEUGAUFNAHMEN
ISO 7388-2
JIS B 6339 (MAS 403 BT)

TOOLHOLDERS
ISO 7388-2
JIS B 6339 (MAS 403 BT)

PORTE-OUTILS
ISO 7388-2
JIS B 6339 (MAS 403 BT)

ISO 7388-2



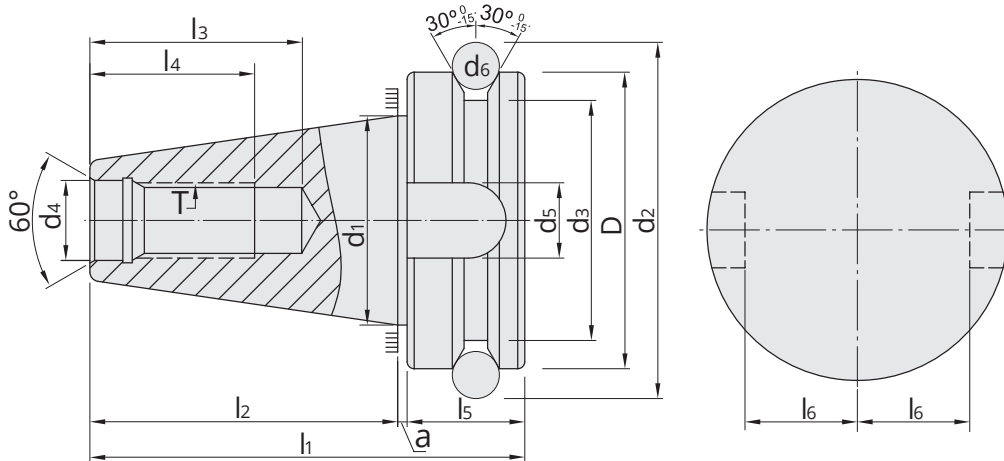

SK	D	d ₁	d ₂	d ₃	d ₄	d ₅	d ₆	d ₉	a	l ₁	l ₂	l ₃	l ₄	l ₅	l ₆	e ₁	e ₂	T
	H8				H8	H12		H12	±0,4		±0,2	min	min		⁰ _{-0,2}	±0,1	max	
30	46	31,75	56,14	38	12,5	16,1	8	-	2	70,4	48,4	34	24	20	16,3	-	-	M12
40	63	44,45	75,679	53	17	16,1	10	4	2	92,4	65,4	43	30	25	22,6	27	5	M16
50	100	69,85	119,02	85	25	25,7	15	6	3	139,8	101,8	62	45	35	35,4	42	7	M24

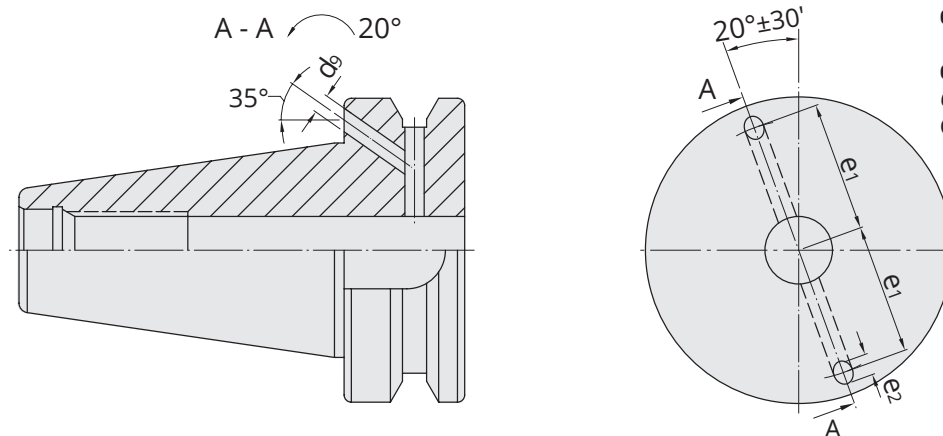
Mit innerer Kühlmittelzufuhr über den Bund - Form JD/JF (AD/B)
With internal coolant through the collar - form JD/JF (AD/B)
Avec arrosage interne par la colletterette - forme JD/JF (AD/B)
Vorgewuchtet
Pre-balanced
Pré-équilibré
G 6,3 15.000 min⁻¹
G 2,5 Feinwuchten gegen Aufpreis
G 2.5 Fine balancing at extra charge
G 2,5 Equilibrage fin contre un supplément

Werkstoff: Legierter Einsatzstahl mit einer Zugfestigkeit im Kern von min. 950 N / mm². Einsatzgehärtet HRC 60 ± 2 (HV 700 ± 50), Härtetiefe 0,8 mm ± 0,2 mm, brüniert und präzisionsgeschliffen.

Form JD/JF: Lieferung in Ausführung JD (AD), Form JF (B) mit lösbaren Gewindestiften verschlossen.

Genauigkeit: Kegelwinkel - Toleranzqualität < AT 3 nach DIN 7187 und DIN 2080.

Material: *Alloyed case-hardened steel, tensile core strength of min. 950 N / mm². Case hardened HRC 60 ± 2 (HV 700 ± 50), hardening depth 0.8 mm ± 0.2 mm, black-finished and precisely grinded.*

Form JD/JF: *Delivery in form JD (AD), form JF (B) closed with releasable headless screws.*

Accuracy: *Quality of taper < AT 3 according to DIN 7187 and DIN 2080.*

Matière: Acier de cémentation allié. Résistance à la traction dans le noyau de min 950 N / mm². Cémentation à HRC 60 ± 2 (HV 700 ± 50), profondeur de cémentation 0,8 mm ± 0,2 mm, bruni et rectifié précisément.

Forme JD/JF: Livraison en forme JD (AD), forme JF (B) fermée avec des vis amovibles sans tête.

Précision: Qualité du cône < AT 3 selon DIN 7187 et DIN 2080.



Index
Sommaire

2

 2.05	 2.06	 2.09	 2.10
 2.11	 2.12	 2.13	 2.17
 2.20	 2.21	 2.22	 2.23
 2.25	 2.27	 2.29	 2.30
 2.31	 2.32	 2.33	 2.34
 2.35	 2.37	 2.38	 2.40
 2.41	 2.45	 2.46	
 2.47	 2.48	 2.49	



Collet chucks DIN 6391 for collets ISO 10897 (DIN 6388) OZ-system
Mandrins à pinces DIN 6391 pour pinces ISO 10897 (DIN 6388) système OZ

2



Verwendung:
Zur Aufnahme von Werkzeugen mit Zylinderschaft in Spannzangen.

Application:
For mounting straight-shank tools in collets.

Application:
Destiné à recevoir les outils avec les queues de forme cylindrique dans les pinces de serrage.

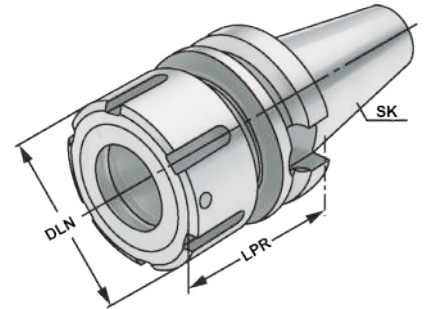

ISO 7388-2	Form JD/JF (AD/B)	≤ 3µm	G2.5 25.000 min ⁻¹	ISO 10897
------------	-------------------	-------	-------------------------------	-----------

13.04

Bestell-Nr. Order no. Référence	SK	DCONWS Spannbereich Capacity Capacité	Typ	LPR	DLN	THID
305.01.16 *	BT 30	2 – 16	415E OZ 16	60	43	M16 x 2,0
305.01.25 *	BT 30	2 – 25	462E OZ 25	80	60	M16 x 2,0
406.01.16	BT 40	2 – 16	415E OZ 16	70	43	M16 x 2,0
406.01.25	BT 40	2 – 25	462E OZ 25	70	60	M16 x 2,0
406.01.32	BT 40	3 – 32	467E OZ 32	90	72	M16 x 2,0
506.01.25	BT 50	2 – 25	462E OZ 25	85	60	M16 x 2,0
506.01.32	BT 50	3 – 32	467E OZ 32	90	72	M16 x 2,0

* Form JD (AD)
* Form JD (AD)
* Form JD (AD)

Lieferumfang: Mit kugelgelagerter Spannmutter
Delivery: With ball bearing clamping nut
Livraison: Avec écrou de serrage à roulement à billes

Gewuchtete Ausführung



Balanced type
Type équilibré

Bestell-Nr. Order no. Référence	Abmessung Size Dimension
---------------------------------------	--------------------------------

Wuchten auf G 2,5 von vorgewuchteten Kemmler-Werkzeugen
Balancing at G 2.5 of pre-balanced Kemmler-tools
Équilibrage sur G 2,5 d'outils Kemmler pré-équilibrés

W25 **Ohne Wuchtprotokoll**
Without balancing report
Sans protocole d'équilibrage

W25.2 **Mit Wuchtprotokoll**
With balancing report
Avec protocole d'équilibrage

Wuchten von nicht vorgewuchteten Werkzeugen
Balancing of unbalanced tools
Équilibrage d'outils non-équilibrés

W25.1 **Ohne Wuchtprotokoll**
Without balancing report
Sans protocole d'équilibrage



Collet chucks for collets ISO 15488 (DIN 6499) ER-system
Mandrins à pinces pour pinces ISO 15488 (DIN 6499) système ER



Verwendung:
Zur Aufnahme von Werkzeugen mit Zylinderschaft in Spannzangen.

Application:
For mounting straight-shank tools in collets.

Application:
Destiné à recevoir les outils avec les queues de forme cylindrique dans les pinces de serrage.

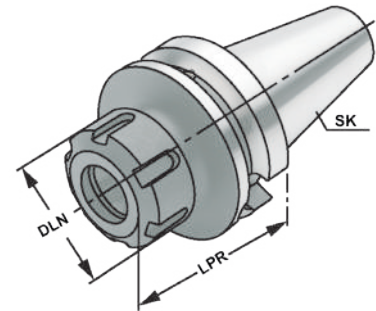

2



Bestell-Nr. Order no. Référence	SK	DCONWS Spannbereich Capacity Capacité	Typ	LPR	DLN	THID
305.02.10	BT 30	1 - 10	426E ER 16	70	32	M10 x 1,5
305.02.13	BT 30	2 - 13	428E ER 20	70	35	M12 x 1,75
305.02.16	BT 30	2 - 16	430E ER 25	70	42	M16 x 2,0
305.02.20	BT 30	2 - 20	470E ER 32	70	50	M16 x 2,0
305.02.26	BT 30	3 - 26	472E ER 40	70	63	M16 x 2,0
305.02.10.1	BT 30	1 - 10	426E ER 16	100	32	M10 x 1,5
305.02.13.1	BT 30	2 - 13	428E ER 20	100	35	M12 x 1,75
305.02.16.1	BT 30	2 - 16	430E ER 25	100	42	M16 x 2,0
305.02.20.1	BT 30	2 - 20	470E ER 32	100	50	M16 x 2,0
405.02.10	BT 40	1 - 10	426E ER 16	63	32	M10 x 1,5
405.02.13	BT 40	2 - 13	428E ER 20	70	35	M12 x 1,75
405.02.16	BT 40	2 - 16	430E ER 25	60	42	M16 x 2,0
405.02.20	BT 40	2 - 20	470E ER 32	70	50	M16 x 2,0
405.02.26	BT 40	3 - 26	472E ER 40	80	63	M16 x 2,0
405.02.10.1	BT 40	1 - 10	426E ER 16	100	32	M10 x 1,5
405.02.13.1	BT 40	2 - 13	428E ER 20	100	35	M12 x 1,75
405.02.16.1	BT 40	2 - 16	430E ER 25	100	42	M16 x 2,0
405.02.20.1	BT 40	2 - 20	470E ER 32	100	50	M16 x 2,0
405.02.26.1	BT 40	3 - 26	472E ER 40	100	63	M16 x 2,0

Lieferumfang: Mit gewuchteter Spannmutter
Delivery: With balanced clamping nut
Livraison: Avec écrou de serrage équilibré





Collet chucks for collets ISO 15488 (DIN 6499) ER-system
Mandrins à pinces pour pinces ISO 15488 (DIN 6499) système ER

2



Verwendung:
Zur Aufnahme von Werkzeugen mit Zylinderschaft in Spannzangen.

Application:
For mounting straight-shank tools in collets.

Application:
Destiné à recevoir les outils avec les queues de forme cylindrique dans les pinces de serrage.

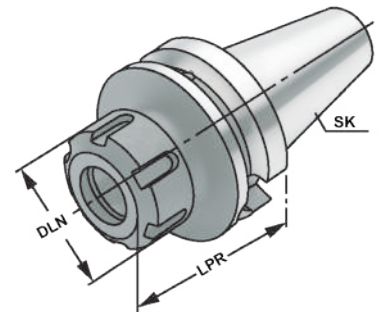

ISO 7388-2 Form JD/JF (AD/B) $\leq 3\mu\text{m}$ G2.5 25.000 min⁻¹ ISO 15488



Bestell-Nr. Order no. Référence	SK	DCONWS Spannbereich Capacity Capacité	Typ	LPR	DLN	THID
406.02.10	BT 40	1 - 10	426E ER 16	63	32	M10 x 1,5
406.02.13	BT 40	2 - 13	428E ER 20	70	35	M12 x 1,75
406.02.16	BT 40	2 - 16	430E ER 25	60	42	M16 x 2,0
406.02.20	BT 40	2 - 20	470E ER 32	70	50	M16 x 2,0
406.02.26	BT 40	3 - 26	472E ER 40	80	63	M16 x 2,0
406.02.10.1	BT 40	1 - 10	426E ER 16	100	32	M10 x 1,5
406.02.13.1	BT 40	2 - 13	428E ER 20	100	35	M12 x 1,75
406.02.16.1	BT 40	2 - 16	430E ER 25	100	42	M16 x 2,0
406.02.20.1	BT 40	2 - 20	470E ER 32	100	50	M16 x 2,0
406.02.26.1	BT 40	3 - 26	472E ER 40	100	63	M16 x 2,0
406.02.10.2	BT 40	1 - 10	426E ER 16	160	32	M10 x 1,5
406.02.13.2	BT 40	2 - 13	428E ER 20	160	35	M12 x 1,75
406.02.16.2	BT 40	2 - 16	430E ER 25	160	42	M16 x 2,0
406.02.20.2	BT 40	2 - 20	470E ER 32	160	50	M16 x 2,0
406.02.26.2	BT 40	3 - 26	472E ER 40	160	63	M16 x 2,0
406.02.10.3	BT 40	1 - 10	426E ER 16	200	32	M10 x 1,5
406.02.13.3	BT 40	2 - 13	428E ER 20	200	35	M12 x 1,75
406.02.16.3	BT 40	2 - 16	430E ER 25	200	42	M16 x 2,0
406.02.20.3	BT 40	2 - 20	470E ER 32	200	50	M16 x 2,0
406.02.26.3	BT 40	3 - 26	472E ER 40	200	63	M16 x 2,0

Lieferumfang: Mit gewuchteter Spannmutter
Delivery: With balanced clamping nut
Livraison: Avec écrou de serrage équilibré

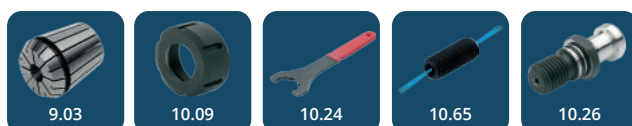

Collet chucks for collets ISO 15488 (DIN 6499) ER-system

Mandrins à pinces pour pinces ISO 15488 (DIN 6499) système ER

**Verwendung:**

Zur Aufnahme von Werkzeugen mit Zylinderschaft in Spannzangen.

Application:

For mounting straight-shank tools in collets.

Application:

Destiné à recevoir les outils avec les queues de forme cylindrique dans les pinces de serrage.

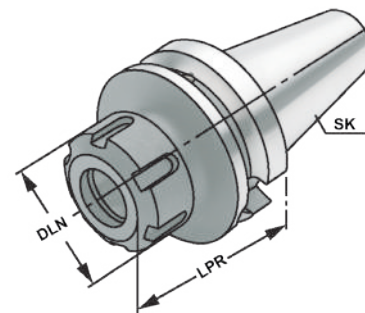

2



Bestell-Nr. Order no. Référence	SK	DCONWS Spannbereich Capacity Capacité	Typ	LPR	DLN	THID
506.02.13	BT 50	2 - 13	428E ER 20	70	35	M12 x 1,75
506.02.16	BT 50	2 - 16	430E ER 25	70	42	M16 x 2,0
506.02.20	BT 50	2 - 20	470E ER 32	70	50	M16 x 2,0
506.02.26	BT 50	3 - 26	472E ER 40	80	63	M16 x 2,0
506.02.10.1	BT 50	1 - 10	426E ER 16	100	32	M10 x 1,5
506.02.13.1	BT 50	2 - 13	428E ER 20	100	35	M12 x 1,75
506.02.16.1	BT 50	2 - 16	430E ER 25	100	42	M16 x 2,0
506.02.20.1	BT 50	2 - 20	470E ER 32	100	50	M16 x 2,0
506.02.26.1	BT 50	3 - 26	472E ER 40	100	63	M16 x 2,0
506.02.10.2	BT 50	1 - 10	426E ER 16	160	32	M10 x 1,5
506.02.13.2	BT 50	2 - 13	428E ER 20	160	35	M12 x 1,75
506.02.16.2	BT 50	2 - 16	430E ER 25	160	42	M16 x 2,0
506.02.20.2	BT 50	2 - 20	470E ER 32	160	50	M16 x 2,0
506.02.26.2	BT 50	3 - 26	472E ER 40	160	63	M16 x 2,0
506.02.10.3	BT 50	1 - 10	426E ER 16	200	32	M10 x 1,5
506.02.13.3	BT 50	2 - 13	428E ER 20	200	35	M12 x 1,75
506.02.16.3	BT 50	2 - 16	430E ER 25	200	42	M16 x 2,0
506.02.20.3	BT 50	2 - 20	470E ER 32	200	50	M16 x 2,0
506.02.26.3	BT 50	3 - 26	472E ER 40	200	63	M16 x 2,0

Lieferumfang: Mit gewuchteter Spannmutter
Delivery: With balanced clamping nut
Livraison: Avec écrou de serrage équilibré

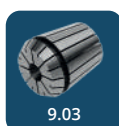

2



Verwendung:
Zur Aufnahme von Werkzeugen mit Zylinderschaft in Spannzangen.

Application:
For mounting straight-shank tools in collets.

Application:
Destiné à recevoir les outils avec les queues de forme cylindrique dans les pinces de serrage.

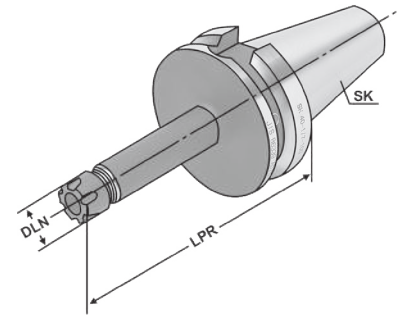

ISO
7388-2

Form
JD/JF
(AD/B)

≤ 3µm

G2.5
25.000
min⁻¹

ISO
15488

13.04

Bestell-Nr. Order no. Référence	SK	DCONWS Spannbereich Capacity Capacité	Typ	LPR	DLN	THID
305.02.07*	BT 30	1 – 7	4008E ER 11	70	16	M8 x 1,25
305.02.07.1*	BT 30	1 – 7	4008E ER 11	100	16	M8 x 1,25
305.02.07.10*	BT 30	1 – 10	426E ER 16	70	22	7/16" 20 UNF
305.02.07.10.1*	BT 30	1 – 10	426E ER 16	100	22	7/16" 20 UNF
406.02.07	BT 40	1 – 7	4008E ER 11	63	16	M8 x 1,25
406.02.07.1	BT 40	1 – 7	4008E ER 11	100	16	M8 x 1,25
406.02.07.2	BT 40	1 – 7	4008E ER 11	160	16	M8 x 1,25
406.02.07.10	BT 40	1 – 10	426E ER 16	55	22	7/16" 20 UNF
406.02.07.10.1	BT 40	1 – 10	426E ER 16	100	22	7/16" 20 UNF
406.02.07.10.2	BT 40	1 – 10	426E ER 16	160	22	7/16" 20 UNF
406.02.07.13	BT 40	2 – 13	428E ER 20	70	28	9/16" 18 UNF
406.02.07.13.1	BT 40	2 – 13	428E ER 20	100	28	9/16" 18 UNF
406.02.07.13.2	BT 40	2 – 13	428E ER 20	160	28	9/16" 18 UNF
406.02.07.16	BT 40	2 – 16	430E ER 25	70	35	11/16" 16 UN
406.02.07.16.1	BT 40	2 – 16	430E ER 25	100	35	11/16" 16 UN
406.02.07.16.2	BT 40	2 – 16	430E ER 25	160	35	11/16" 16 UN

* Form JD (AD)
* Form JD (AD)
* Form JD (AD)

Lieferumfang: Mit gewichteter Spannmutter und Verstellerschraube
Delivery: With balanced clamping nut and adjusting screw
Livraison: Avec écrou de serrage équilibré et vis de réglage



Precision collet chuck ER for collets ISO 15488 (DIN 6499) ER-system

Mandrin à pinces ER de précision pour pinces ISO 15488 (DIN 6499) système ER



Verwendung:
Zur Aufnahme von Werkzeugen mit Zylinderschaft in 3 µm-Spannzangen.

Application:
For mounting straight-shank tools in 3 µm-collets.

Application:
Pour le serrage d'outils avec queue cylindrique dans des pinces de serrage 3 µm.

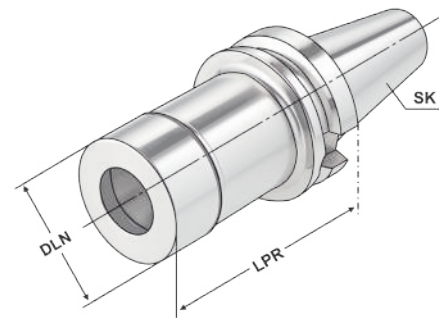

Bestell-Nr. Order no. Référence	SK	DCONWS Spannbereich Capacity Capacité	Typ	LPR	LB	DLN	THID
305.P2.20.070	BT 30	2 - 20	470E ER 32	70	48	50	M16 x 2,0
405.P2.20.070	BT 40	2 - 20	470E ER 32	70	43	50	M16 x 2,0
405.P2.20.100	BT 40	2 - 20	470E ER 32	100	73	50	M16 x 2,0
405.P2.20.125	BT 40	2 - 20	470E ER 32	125	98	50	M16 x 2,0
405.P2.20.150	BT 40	2 - 20	470E ER 32	150	123	50	M16 x 2,0
405.P2.20.200	BT 40	2 - 20	470E ER 32	200	173	50	M16 x 2,0
505.P2.20.070	BT 50	2 - 20	470E ER 32	70	32	50	M16 x 2,0
505.P2.20.100	BT 50	2 - 20	470E ER 32	100	62	50	M16 x 2,0
505.P2.20.125	BT 50	2 - 20	470E ER 32	125	87	50	M16 x 2,0
505.P2.20.150	BT 50	2 - 20	470E ER 32	150	112	50	M16 x 2,0
505.P2.20.200	BT 50	2 - 20	470E ER 32	200	162	50	M16 x 2,0

Vorteile:

Exzellente Rundlaufgenauigkeit im System (Futter + Spannzange + Spannmutter)
 Extreme Haltekräfte (erhöht die Haltekraft um mindestens 60 % im Vergleich zu Standard ER-Futter)
 Glatte Spannmutter ohne Nuten für Hochgeschwindigkeitsbearbeitung

Advantages:

Excellent concentricity in the system (chuck + collet + clamping nut)
 Extremely strong holding force (increases the holding power by at least 60% compared to standard ER chuck)
 Plain clamping nut without grooves for high speed machining

Avantages:

Excellente précision de concentricité dans le système (mandrin + pince de serrage + écrou de serrage)
 La force de maintien extrême (augmente la force de maintien d'au moins à 60% par rapport aux mandrins standards ER)
 Ecrou de serrage lisse sans rainures pour l'usinage à haute vitesse

Hinweis:

Nur das Nennmaß DCONWS kann gespannt werden.

Note:

Only nominal size DCONWS can be clamped.

Observation:

Seulement la dimension nominale DCONWS peut être serrée.

Lieferumfang:

Inklusive Präzisions-Spannmutter

Delivery:

With precision clamping nut

Livraison:

Avec écrou de serrage de précision



2



Verwendung:
Zur Aufnahme von Werkzeugen mit Zylinder-
schaft in Spannzangen.
Für Anwendungen im HSC-Bereich und für
hochpräzise Bearbeitungsergebnisse.

Application:
For mounting straight-shank tools in collets.
To use for high speed cutting and high precision
milling.

Utilisation:
Pour la fixation d'outils à queue cylindrique
dans les pinces de serrage. Pour l'UGV (Usi-
nage à Grande Vitesse) et pour des résultats
d'usinage de haute précision.

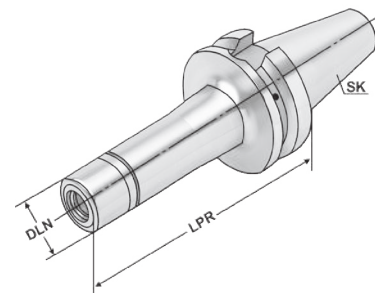

ISO 7388-2 Form JD (AD) $\leq 3\mu\text{m}$ G2.5 30,000 min⁻¹ KPS

13.04

Bestell-Nr. Order no. Référence	SK	DCONWS Spannbereich Capacity Capacité	Typ	LPR	DLN	THID
305.03.10	BT 30	1 – 10	490EK KPS 10	60	27,5	M12 x 1,75
305.03.16	BT 30	4 – 16	496EK KPS 16	60	40	M18 x 1,50
305.03.10.1	BT 30	1 – 10	490EK KPS 10	90	27,5	M12 x 1,75
305.03.16.1	BT 30	4 – 16	496EK KPS 16	90	40	M18 x 1,50
405.03.10	BT 40	1 – 10	490EK KPS 10	60	27,5	M12 x 1,75
405.03.16	BT 40	4 – 16	496EK KPS 16	60	40	M18 x 1,50
405.03.10.1	BT 40	1 – 10	490EK KPS 10	90	27,5	M12 x 1,75
405.03.16.1	BT 40	4 – 16	496EK KPS 16	90	40	M18 x 1,50
405.03.10.2	BT 40	1 – 10	490EK KPS 10	120	27,5	M12 x 1,75
405.03.16.2	BT 40	4 – 16	496EK KPS 16	120	40	M18 x 1,50
405.03.10.3	BT 40	1 – 10	490EK KPS 10	160	27,5	M12 x 1,75
405.03.16.3	BT 40	4 – 16	496EK KPS 16	160	40	M18 x 1,50
505.03.10	BT 50	1 – 10	490EK KPS 10	105	27,5	M12 x 1,75
505.03.16	BT 50	4 – 16	496EK KPS 16	105	40	M18 x 1,50
505.03.10.1	BT 50	1 – 10	490EK KPS 10	135	27,5	M12 x 1,75
505.03.16.1	BT 50	4 – 16	496EK KPS 16	135	40	M18 x 1,50
505.03.10.2	BT 50	1 – 10	490EK KPS 10	165	27,5	M12 x 1,75
505.03.16.2	BT 50	4 – 16	496EK KPS 16	165	40	M18 x 1,50

Lieferumfang: Mit gewuchteter Spannmutter
Delivery: With balanced clamping nut
Livraison: Avec écrou de serrage équilibré





Verwendung:
Zur Aufnahme von Werkzeugen mit Zylinderschaft nach DIN 1835 Form A+B+E und DIN 6535 Form HB+HE

Application:
For mounting straight-shank tools acc. DIN 1835 form A+B+E and DIN 6535 form HB+HE

Application:
Destiné à recevoir les outils avec les queues de forme cylindrique suivant DIN 1835 en forme A+B+E et DIN 6535 en forme HB+HE

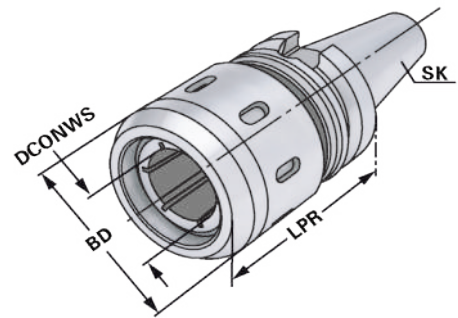

ISO 7388-2	Form JD/JF (AD/B)	≤ 3µm	G6.3 15.000 min ⁻¹	HKS	13.04
------------	-------------------	-------	-------------------------------	-----	-------

Bestell-Nr. Order no. Référence	SK	DCONWS Spannbereich Capacity Capacité	Typ	DCONWS	LPR	BD
406.64.20	BT 40	3 - 20	HKS 20	20	90	53
406.64.25	BT 40	3 - 25	HKS 25	25	90	63
406.64.32	BT 40	3 - 32	HKS 32	32	90	68
506.64.20	BT 50	3 - 20	HKS 20	20	95	53
506.64.25	BT 50	3 - 25	HKS 25	25	95	63
506.64.32	BT 50	3 - 32	HKS 32	32	90	68

Größe Size Taille	20mm	25mm	32mm
Anzugsmoment Clamping torque Couple	50-70 Nm	80-100 Nm	80-100 Nm
Spannkraft Clamping force Tension	780 Nm	2000 Nm	2000 Nm

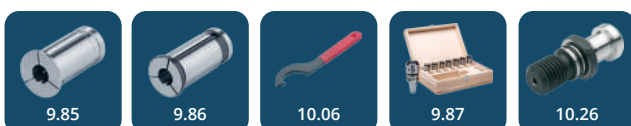

2



Verwendung:
 Zum Spannen von zylindrischen Werkzeugschäften mit seitlicher Spannfläche nach DIN 1835 Form B (Weldon).

Application:
 For mounting straight-shank tools with lateral flat according to DIN 1835 form B (Weldon).

Application:
 Pour le serrage d'outils avec queue cylindrique et avec méplat de serrage latérale suivant DIN 1835 forme B (Weldon).

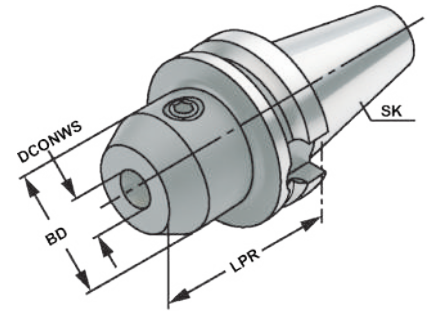

ISO 7388-2	Form JD (AD)	$\leq 3\mu\text{m}$	G7.5 25.000 min ⁻¹	DIN 1835-B	H4	13.04
------------	--------------	---------------------	-------------------------------	------------	----	-------

Bestell-Nr. Order no. Référence	SK	DCONWS	TDCON	LPR	BD
305.04.06	BT 30	6	H4	50	25
305.04.08	BT 30	8	H4	50	28
305.04.10	BT 30	10	H4	50	35
305.04.12	BT 30	12	H4	50	42
305.04.14	BT 30	14	H4	50	44
305.04.16	BT 30	16	H4	63	48
305.04.18	BT 30	18	H4	63	50
305.04.20	BT 30	20	H4	63	52
405.04.06	BT 40	6	H4	50	25
405.04.08	BT 40	8	H4	50	28
405.04.10	BT 40	10	H4	63	35
405.04.12	BT 40	12	H4	63	42
405.04.14	BT 40	14	H4	63	44
405.04.16	BT 40	16	H4	63	48
405.04.18	BT 40	18	H4	63	50
405.04.20	BT 40	20	H4	63	52
405.04.25	BT 40	25	H4	90	65
405.04.32	BT 40	32	H4	100	72
405.04.06.1	BT 40	6	H4	100	25
405.04.08.1	BT 40	8	H4	100	28
405.04.10.1	BT 40	10	H4	100	35
405.04.12.1	BT 40	12	H4	100	42
405.04.14.1	BT 40	14	H4	100	44
405.04.16.1	BT 40	16	H4	100	48
405.04.18.1	BT 40	18	H4	100	50
405.04.20.1	BT 40	20	H4	100	52

Hinweis: Ab DCONWS = 25 mit zwei Spannschrauben
Note: From DCONWS = 25 on two clamping screws
Observation: À partir de DCONWS = 25 avec deux vis de serrage

Lieferumfang: Mit Spannschraube
Delivery: With clamping screw
Livraison: Avec vis de serrage



End mill holders DIN 6359 for end mills DIN 1835-B

(JIS B 6339)

Porte-fraises DIN 6359 pour queues cylindriques DIN 1835-B

**Verwendung:**

Zum Spannen von zylindrischen Werkzeugschäften mit seitlicher Spannfläche nach DIN 1835 Form B (Weldon).

Application:

For mounting straight-shank tools with lateral flat according to DIN 1835 form B (Weldon).

Application:

Pour le serrage d'outils avec queue cylindrique et avec méplat de serrage latérale suivant DIN 1835 forme B (Weldon).

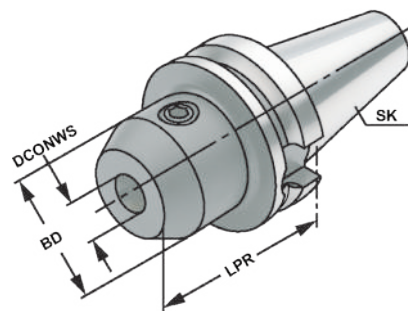

2

ISO
7388-2Form
JD/JF
(AD/B)

 $\leq 3\mu\text{m}$

 $G2.5$
 $25,000$
 min^{-1}
DIN
1835-B

H4

 13.04
Bestell-Nr.
Order no.
Référence

SK

DCONWS

TDCON

LPR

BD

406.04.16.0	BT 40	16	H4	35	45
406.04.20.0	BT 40	20	H4	35	45
406.04.25.0	BT 40	25	H4	35	45
406.04.32.0	BT 40	32	H4	65	62

406.04.06	BT 40	6	H4	50	25
406.04.08	BT 40	8	H4	50	28
406.04.10	BT 40	10	H4	63	35
406.04.12	BT 40	12	H4	63	42
406.04.14	BT 40	14	H4	63	44
406.04.16	BT 40	16	H4	63	48
406.04.18	BT 40	18	H4	63	50
406.04.20	BT 40	20	H4	63	52
406.04.25	BT 40	25	H4	90	65
406.04.32	BT 40	32	H4	100	72
406.04.40	BT 40	40	H4	120	80

406.04.06.1	BT 40	6	H4	100	25
406.04.08.1	BT 40	8	H4	100	28
406.04.10.1	BT 40	10	H4	100	35
406.04.12.1	BT 40	12	H4	100	42
406.04.14.1	BT 40	14	H4	100	44
406.04.16.1	BT 40	16	H4	100	48
406.04.18.1	BT 40	18	H4	100	50
406.04.20.1	BT 40	20	H4	100	52

406.04.06.2	BT 40	6	H4	160	25
406.04.08.2	BT 40	8	H4	160	28
406.04.10.2	BT 40	10	H4	160	35
406.04.12.2	BT 40	12	H4	160	42
406.04.14.2	BT 40	14	H4	160	44
406.04.16.2	BT 40	16	H4	160	48
406.04.18.2	BT 40	18	H4	160	50
406.04.20.2	BT 40	20	H4	160	52
406.04.25.2	BT 40	25	H4	160	65
406.04.32.2	BT 40	32	H4	160	72
406.04.40.2	BT 40	40	H4	160	80

2



Verwendung:
 Zum Spannen von zylindrischen Werkzeugschäften mit seitlicher Spannfläche nach DIN 1835 Form B (Weldon).

Application:
 For mounting straight-shank tools with lateral flat according to DIN 1835 form B (Weldon).

Application:
 Pour le serrage d'outils avec queue cylindrique et avec méplat de serrage latérale suivant DIN 1835 forme B (Weldon).

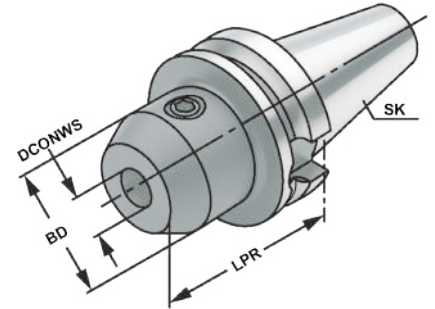

Bestell-Nr. Order no. Référence	SK	DCONWS	TDCON	LPR	BD
506.04.06	BT 50	6	H4	63	25
506.04.08	BT 50	8	H4	63	28
506.04.10	BT 50	10	H4	63	35
506.04.12	BT 50	12	H4	80	42
506.04.14	BT 50	14	H4	80	44
506.04.16	BT 50	16	H4	80	48
506.04.18	BT 50	18	H4	80	50
506.04.20	BT 50	20	H4	80	52
506.04.25	BT 50	25	H4	100	65
506.04.32	BT 50	32	H4	105	72
506.04.40	BT 50	40	H4	110	80
506.04.06.1	BT 50	6	H4	100	25
506.04.08.1	BT 50	8	H4	100	28
506.04.10.1	BT 50	10	H4	100	35
506.04.12.1	BT 50	12	H4	100	42
506.04.14.1	BT 50	14	H4	100	44
506.04.16.1	BT 50	16	H4	100	48
506.04.18.1	BT 50	18	H4	100	50
506.04.20.1	BT 50	20	H4	100	52
506.04.06.2	BT 50	6	H4	160	25
506.04.08.2	BT 50	8	H4	160	28
506.04.10.2	BT 50	10	H4	160	35
506.04.12.2	BT 50	12	H4	160	42
506.04.14.2	BT 50	14	H4	160	44
506.04.16.2	BT 50	16	H4	160	48
506.04.18.2	BT 50	18	H4	160	50
506.04.20.2	BT 50	20	H4	160	52
506.04.25.2	BT 50	25	H4	160	65
506.04.32.2	BT 50	32	H4	160	72
506.04.40.2	BT 50	40	H4	160	80

Hinweis: Ab DCONWS = 25 mit zwei Spansschrauben
Note: From DCONWS = 25 on two clamping screws
Observation: À partir de DCONWS = 25 avec deux vis de serrage

Lieferumfang: Mit Spansschraube
Delivery: With clamping screw
Livraison: Avec vis de serrage



End mill holders DIN 6359 for end mills DIN 1835-B

(JIS B 6339)

Porte-fraises DIN 6359 pour queues cylindriques DIN 1835-B

**Verwendung:**

Zum Spannen von zylindrischen Werkzeugschäften mit seitlicher Spannfläche nach DIN 1835 Form B (Weldon).

Application:

For mounting straight-shank tools with lateral flat according to DIN 1835 form B (Weldon).

Application:

Pour le serrage d'outils avec queue cylindrique et avec méplat de serrage latérale suivant DIN 1835 forme B (Weldon).

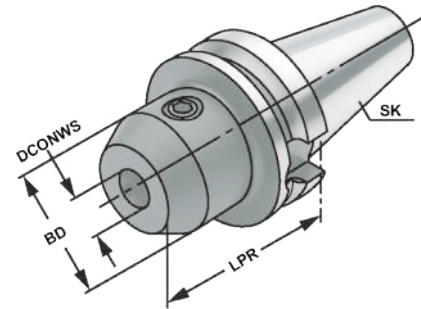

2

ISO
7388-2Form
JD/JF
(AD/B)

 $\leq 3\mu\text{m}$

 $G2.5$
 $25,000$
 min^{-1}
DIN
1835-B

H4

 13.04
Bestell-Nr.
Order no.
Référence

SK

DCONWS

TDCON

LPR

BD

506.04.06.3

BT 50

6

H4

200

25

506.04.08.3

BT 50

8

H4

200

28

506.04.10.3

BT 50

10

H4

200

35

506.04.12.3

BT 50

12

H4

200

42

506.04.14.3

BT 50

14

H4

200

44

506.04.16.3

BT 50

16

H4

200

48

506.04.18.3

BT 50

18

H4

200

50

506.04.20.3

BT 50

20

H4

200

52

506.04.25.3

BT 50

25

H4

200

65

506.04.32.3

BT 50

32

H4

200

72

506.04.40.3

BT 50

40

H4

200

80

Hinweis:

Ab DCONWS = 25 mit zwei Spannschrauben

Note:

From DCONWS = 25 on two clamping screws

Observation:

À partir de DCONWS = 25 avec deux vis de serrage

Lieferumfang:

Mit Spannschraube

Delivery:

With clamping screw

Livraison:

Avec vis de serrage

**Nachträgliches Erodieren von 2 Kühlkanalbohrungen**

Supplementary eroding of 2 cooling channels

Erodage complémentaire de 2 trous de canaux de refroidissement

Bestell-Nr.
Order no.
Référence

U.KKB



10.64



10.26

End mill holders DIN 6359 with coolant channels for end mills DIN 1835-B
Porte-fraises DIN 6359 avec canaux d'arrosage pour queues cylindriques DIN 1835-B

2



Verwendung:

Zum Spannen von zylindrischen Werkzeugschäften mit seitlicher Spannfläche nach DIN 1835 Form B (Weldon). Mit Kühlkanälen für optimale Kühlung der Werkzeugschneide.

Application:

For mounting straight-shank tools with lateral flat according to DIN 1835 form B (Weldon). With coolant channels for optimal coolant at the cutting edge.

Application:

Pour le serrage d'outils avec queue cylindrique et avec méplat de serrage latéral suivant DIN 1835 forme B (Weldon). Avec canaux d'arrosage pour refroidissement optimal des coupes.

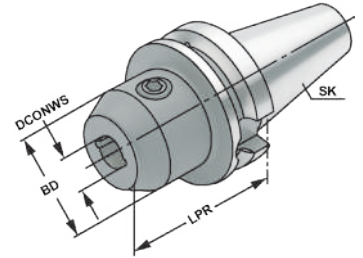

ISO 7388-2	Form JD/JF (AD/B)	≤ 3µm	G2.5 25.000 min ⁻¹	DIN 1835-B	H4		
------------	-------------------	-------	-------------------------------	------------	----	--	--

Bestell-Nr. Order no. Référence	SK	DCONWS	TDCON	LPR	BD
406.04.06.K	BT 40	6	H4	63	25
406.04.08.K	BT 40	8	H4	63	28
406.04.10.K	BT 40	10	H4	63	35
406.04.12.K	BT 40	12	H4	80	42
406.04.14.K	BT 40	14	H4	80	44
406.04.16.K	BT 40	16	H4	80	48
406.04.18.K	BT 40	18	H4	80	50
406.04.20.K	BT 40	20	H4	80	52
406.04.25.K	BT 40	25	H4	100	65
406.04.32.K	BT 40	32	H4	105	72
406.04.40.K	BT 40	40	H4	110	80
406.04.06.1.K	BT 40	6	H4	100	25
406.04.08.1.K	BT 40	8	H4	100	28
406.04.10.1.K	BT 40	10	H4	100	35
406.04.12.1.K	BT 40	12	H4	100	42
406.04.14.1.K	BT 40	14	H4	100	44
406.04.16.1.K	BT 40	16	H4	100	48
406.04.18.1.K	BT 40	18	H4	100	50
406.04.20.1.K	BT 40	20	H4	100	52

Hinweis: Ab DCONWS = 25 mit zwei Spannschrauben
DCONWS = 6 bis 18 mit zwei Kühlkanälen
DCONWS = 20 bis 40 mit vier Kühlkanälen
Für Werkzeuge mit innerer Kühlmittelzufuhr muss ein O-Ring eingesetzt werden.

Note: From DCONWS = 25 on two clamping screws
DCONWS = 6 to 18 with two coolant channels
DCONWS = 20 to 40 with four coolant channels
For tools with through coolant an O-ring must be used.

Observation: À partir de DCONWS = 25 avec deux vis de serrage
DCONWS = 6 bis 18 avec deux canaux d'arrosage
DCONWS = 20 bis 40 avec quatre canaux d'arrosage
Pour outils avec arrosage interne il faut utiliser un joint torique.



Lieferumfang: Mit Spannschraube und O-Ring
Delivery: With clamping screw and O-ring
Livraison: Avec vis de serrage et joint torique



End mill holders DIN 6359 with coolant channels for end mills DIN 1835-B

Porte-fraises DIN 6359 avec canaux d'arrosage pour queues cylindriques DIN 1835-B

**Verwendung:**

Zum Spannen von zylindrischen Werkzeugschäften mit seitlicher Spannfläche nach DIN 1835 Form B (Weldon). Mit Kühlkanälen für optimale Kühlung der Werkzeugschneide.

Application:

For mounting straight-shank tools with lateral flat according to DIN 1835 form B (Weldon). With coolant channels for optimal coolant at the cutting edge.

Application:

Pour le serrage d'outils avec queue cylindrique et avec méplat de serrage latéral suivant DIN 1835 forme B (Weldon). Avec canaux d'arrosage pour refroidissement optimal des coupes.

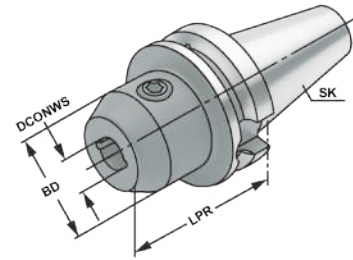

2

Form
JD/JF
(AD/B)DIN
1835-B

H4

Bestell-Nr.
Order no.
Référence

SK

DCONWS

TDCON

LPR

BD

506.04.06.K

BT 50

6

H4

63

25

506.04.08.K

BT 50

8

H4

63

28

506.04.10.K

BT 50

10

H4

63

35

506.04.12.K

BT 50

12

H4

80

42

506.04.14.K

BT 50

14

H4

80

44

506.04.16.K

BT 50

16

H4

80

48

506.04.18.K

BT 50

18

H4

80

50

506.04.20.K

BT 50

20

H4

80

52

506.04.25.K

BT 50

25

H4

100

65

506.04.32.K

BT 50

32

H4

105

72

506.04.40.K

BT 50

40

H4

110

80

Hinweis:

Ab DCONWS = 25 mit zwei Spannschrauben
DCONWS = 6 bis 18 mit zwei Kühlkanälen
DCONWS = 20 bis 40 mit vier Kühlkanälen

Für Werkzeuge mit innerer Kühlmittelzufuhr muss ein O-Ring eingesetzt werden.

Note:

From DCONWS = 25 on two clamping screws
DCONWS = 6 to 18 with two coolant channels
DCONWS = 20 to 40 with four coolant channels

For tools with through coolant an O-ring must be used.

Observation:

À partir de DCONWS = 25 avec deux vis de serrage
DCONWS = 6 bis 18 avec deux canaux d'arrosage
DCONWS = 20 bis 40 avec quatre canaux d'arrosage

Pour outils avec arrosage interne il faut utiliser un joint torique.

**Lieferumfang:**

Mit Spannschraube und O-Ring

Delivery:

With clamping screw and O-ring

Livraison:

Avec vis de serrage et joint torique



10.64



10.26



10.97

2



Verwendung:
 Zum Spannen von zylindrischen Werkzeugschäften mit geneigter Spannfläche nach DIN 1835 Form E (Whistle Notch).

Application:
 For mounting straight-shank tools and inclined flat according to DIN 1835 form E (Whistle Notch).

Application:
 Pour le serrage d'outils avec queue cylindrique et avec méplat incliné suivant DIN 1835 forme E (Whistle Notch).

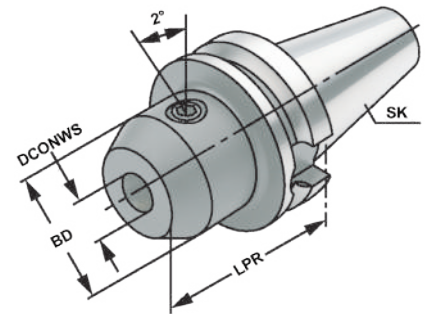

ISO 7388-2	Form JD/JF (AD/B)	$\leq 3\mu\text{m}$	G7.5 25.000 min ⁻¹	DIN 1835-E	H4	13.04
------------	-------------------	---------------------	-------------------------------	------------	----	-------

Bestell-Nr. Order no. Référence	SK	DCONWS	TDCON	LPR	BD
406.05.06	BT 40	6	H4	50	25
406.05.08	BT 40	8	H4	50	28
406.05.10	BT 40	10	H4	63	35
406.05.12	BT 40	12	H4	63	42
406.05.14	BT 40	14	H4	63	44
406.05.16	BT 40	16	H4	63	48
406.05.18	BT 40	18	H4	63	50
406.05.20	BT 40	20	H4	63	52
406.05.25	BT 40	25	H4	90	65
406.05.32	BT 40	32	H4	100	72
406.05.40	BT 40	40	H4	120	80
506.05.06	BT 50	6	H4	63	25
506.05.08	BT 50	8	H4	63	28
506.05.10	BT 50	10	H4	63	35
506.05.12	BT 50	12	H4	80	42
506.05.14	BT 50	14	H4	80	44
506.05.16	BT 50	16	H4	80	48
506.05.18	BT 50	18	H4	80	50
506.05.20	BT 50	20	H4	80	52
506.05.25	BT 50	25	H4	100	65
506.05.32	BT 50	32	H4	105	72
506.05.40	BT 50	40	H4	110	80

Hinweis: Ab DCONWS = 25 mit zwei Spannschrauben
Note: From DCONWS = 25 on two clamping screws
Observation: A partir de DCONWS = 25 avec deux vis de serrage

Lieferumfang: Mit Spannschraube und axialer Verstellechraube
Delivery: With clamping screw and axial adjustment bolt
Livraison: Avec vis de serrage et vis de butée axiale





Verwendung:
 Zur Aufnahme von Werkzeugen mit Morsekegelschaft und Austreibblappen nach DIN 228-1 Form B.

Application:
 For mounting tools with Morse taper shank and tang according to DIN 228-1 form B.

Application:
 Pour le serrage d'outils avec queue cône Morse et tenon suivant DIN 228-1 forme B.

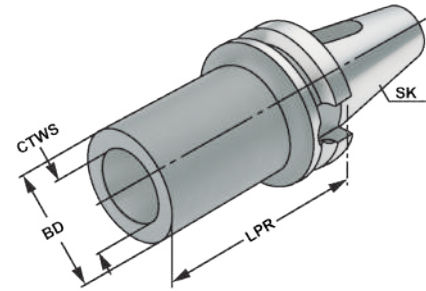

ISO 7388-2	Form JD/JF (AD/B)	≤ 5µm	G6.3 15.000 min ⁻¹	DIN 6383	AT5
------------	-------------------	-------	-------------------------------	----------	-----

Bestell-Nr. Order no. Référence	SK	CTWS	TDCON	LPR	BD
305.07.01*	BT 30	1	AT5	45	25
305.07.02*	BT 30	2	AT5	60	32
305.07.03*	BT 30	3	AT5	75	40
405.07.01*	BT 40	1	AT5	50	25
405.07.02*	BT 40	2	AT5	50	32
405.07.03*	BT 40	3	AT5	70	40
405.07.04*	BT 40	4	AT5	95	48
406.07.01	BT 40	1	AT5	50	25
406.07.02	BT 40	2	AT5	50	32
406.07.03	BT 40	3	AT5	70	40
406.07.04	BT 40	4	AT5	95	48
506.07.01	BT 50	1	AT5	45	25
506.07.02	BT 50	2	AT5	60	32
506.07.03	BT 50	3	AT5	65	40
506.07.04	BT 50	4	AT5	95	48
506.07.05	BT 50	5	AT5	105	63

* Form JD (AD)
 * Form JD (AD)
 * Form JD (AD)





2



Verwendung:

Zum Spannen von Werkzeugen mit Morsekegelschaft und Anzugsgewinde nach DIN 228-1 Form A.

Application:

For clamping tools with Morse taper shank and thread according to DIN 228-1 form A.

Application:

Pour le serrage d'outils avec queue cône Morse et filetage suivant DIN 228-1 forme A.

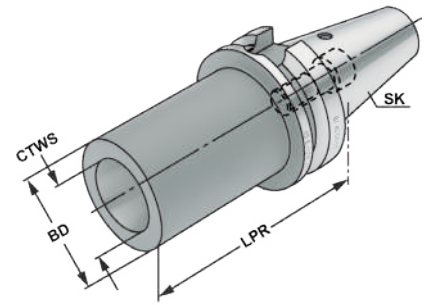

ISO 7388-2	Form J (A)	$\leq 5\mu\text{m}$	G6.3 15.000 min ⁻¹	DIN 6364	AT5
------------	------------	---------------------	-------------------------------	----------	-----

Bestell-Nr. Order no. Référence	SK	CTWS	THID	LPR	BD
405.08.01	BT 40	1	M6	50	25
405.08.02	BT 40	2	M10	50	32
405.08.03	BT 40	3	M12	70	40
405.08.04	BT 40	4	M16	95	48
405.08.04A*	BT 40	4	M16	110	63
505.08.01	BT 50	1	M6	45	25
505.08.02	BT 50	2	M10	60	32
505.08.03	BT 50	3	M12	65	40
505.08.04	BT 50	4	M16	70	48
505.08.04A*	BT 50	4	M16	85	63
505.08.05	BT 50	5	M20	100	63
505.08.05A*	BT 50	5	M20	118	78

- * Mit Mitnahmeausfräsung nach DIN 2201
- * With drive flats according to DIN 2201
- * Avec des fraises d'entraînement suivant DIN 2201

Lieferumfang: Mit eingebauter Fräseranzugsschraube
Delivery: With built-in tightening bolt
Livraison: Avec vis de serrage montée





Verwendung:

Zur Aufnahme von Steilkegeln nach DIN 69871, JIS B 6339 und DIN 2080.

Application:

For holding tapers according to DIN 69871, JIS B 6339 and DIN 2080.

Application:

Pour le serrage de porte-outils suivant DIN 69871, JIS B 6339 et DIN 2080.

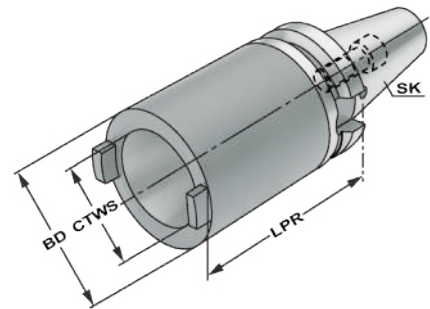

ISO 7388-2	Form J (A)	$\leq 5\mu\text{m}$	G6.3 15.000 min ⁻¹	AT5
---------------	------------------	---------------------	-------------------------------------	-----

Bestell-Nr. Order no. Référence	SK	CTWS	LPR	BD
405.09.30	BT 40	SK 30	60	63
405.09.40	BT 40	SK 40	100	63
505.09.40	BT 50	SK 40	70	70
505.09.50	BT 50	SK 50	120	97

Hinweis: Lieferung erfolgt mit eingebauter Schraube für Werkzeuge mit gekürztem Steilkegel. Schraube für DIN 2080 Werkzeuge beiliegend.

Note: Delivered with a built-in screw for shortened taper tools. Additional screw for DIN 2080 tools included.

Observation: Livraison avec un vis incorporée pour outils à cône court. Vis pour cônes DIN 2080 incluse.



2



Verwendung:

Zur Aufnahme von Walzen-, Walzenstirnfräsern oder Messerköpfen mit Längs- oder Quernut.

Application:

For mounting milling cutters with transverse or longitudinal groove.

Application:

Destiné à recevoir les porte-fraises, les fraises cylindriques ou les têtes de fraisage avec rainure longitudinale et transversale.

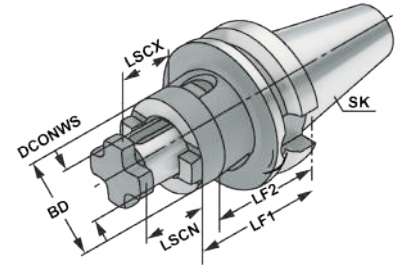

ISO
7388-2

Form
JD/JF
(AD/B)

≤ 5µm

G6.3
15.000
min⁻¹

DIN
6358

h6

Bestell-Nr. Order no. Référence	SK	DCONWS	TDCON	LF1	LF2	LSCN	LSCX	BD
305.10.16*	BT 30	16	h6	45	35	17	27	32
305.10.22*	BT 30	22	h6	47	35	19	31	40
305.10.27*	BT 30	27	h6	49	35	21	33	48
406.10.16	BT 40	16	h6	55	45	17	27	32
406.10.22	BT 40	22	h6	55	43	19	31	40
406.10.27	BT 40	27	h6	55	43	21	33	48
406.10.32	BT 40	32	h6	60	46	24	38	58
406.10.40	BT 40	40	h6	60	46	27	41	70
406.10.16.1	BT 40	16	h6	100	90	17	27	32
406.10.22.1	BT 40	22	h6	100	88	19	31	40
406.10.27.1	BT 40	27	h6	100	88	21	33	48
406.10.32.1	BT 40	32	h6	100	86	24	38	58
406.10.40.1	BT 40	40	h6	100	86	27	41	70
406.10.16.2	BT 40	16	h6	160	150	17	27	32
406.10.22.2	BT 40	22	h6	160	148	19	31	40
406.10.27.2	BT 40	27	h6	160	148	21	33	48
406.10.32.2	BT 40	32	h6	160	146	24	38	58
406.10.40.2	BT 40	40	h6	160	146	27	41	70

- * Form JD (AD)
- * Form JD (AD)
- * Form JD (AD)

Lieferumfang: Mit Fräseranzugsschraube, Mitnehmerring und Passfeder
Delivery: With retaining screw, driving ring and feather key
Livraison: Avec vis de serrage, bague d'entraînement et clavette





Verwendung:

Zur Aufnahme von Walzen-, Walzenstirnfräsern oder Messerköpfen mit Längs- oder Quernut.

Application:

For mounting milling cutters with transverse or longitudinal groove.

Application:

Destiné à recevoir les porte-fraises, les fraises cylindriques ou les têtes de fraisage avec rainure longitudinale et transversale.

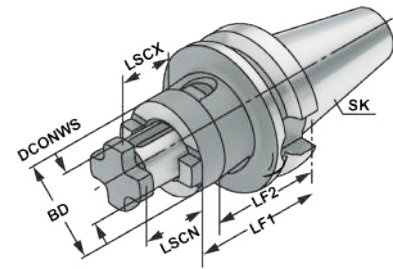

ISO 7388-2 Form JD/JF (AD/B) ≤ 5µm G6.3 15.000 min⁻¹ DIN 6358 h6

Bestell-Nr. Order no. Référence	SK	DCONWS	TDCON	LF1	LF2	LSCN	LSCX	BD
506.10.16	BT 50	16	h6	70	60	17	27	32
506.10.22	BT 50	22	h6	70	58	19	31	40
506.10.27	BT 50	27	h6	70	58	21	33	48
506.10.32	BT 50	32	h6	70	56	24	38	58
506.10.40	BT 50	40	h6	70	56	27	41	70
506.10.16.2	BT 50	16	h6	160	150	17	27	32
506.10.22.2	BT 50	22	h6	160	148	19	31	40
506.10.27.2	BT 50	27	h6	160	148	21	33	48
506.10.32.2	BT 50	32	h6	160	146	24	38	58
506.10.40.2	BT 50	40	h6	160	146	27	41	70

Lieferumfang: Mit Fräseranzugsschraube, Mitnehmerring und Passfeder
Delivery: With retaining screw, driving ring and feather key
Livraison: Avec vis de serrage, bague d'entraînement et clavette



Nachträgliches Erodieren von 2 Kühlkanalbohrungen

Supplementary eroding of 2 cooling channels

Erodage complémentaire de 2 trous de canaux de refroidissement

Bestell-Nr.
Order no.
Référence

U.KKB





Shell mill holders DIN 6357 with enlarged contact face and coolant exit bores on the end face

Porte-fraises à trou lisse DIN 6357 avec face de contact élargie et conduits pour l'arrosage frontal

2



Verwendung:

Zur Aufnahme von Messerköpfen und Fräsern mit Quernut.

Application:

For mounting milling cutters with transversal groove.

Application:

Destiné à recevoir les fraises et les fraises avec des rainures transversales.

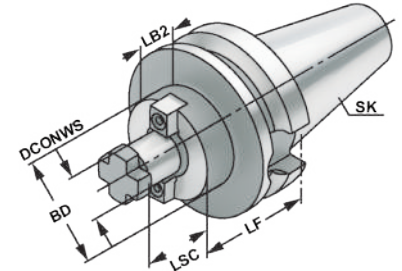

Bestell-Nr. Order no. Référence	SK	DCONWS	TDCON	LF	LSC	LB2	BD
305.11.16*	BT 30	16	h6	40	17	18	38
305.11.22*	BT 30	22	h6	40	19	18	48
305.11.27*	BT 30	27	h6	40	21	18	58
305.11.32*	BT 30	32	h6	50	24	28	78
405.11.16*	BT 40	16	h6	40	17	13	38
405.11.22*	BT 40	22	h6	40	19	13	48
405.11.27*	BT 40	27	h6	40	21	13	58
405.11.32*	BT 40	32	h6	50	24	23	78
405.11.40*	BT 40	40	h6	50	27	23	88
406.11.16	BT 40	16	h6	40	17	13	38
406.11.22	BT 40	22	h6	40	19	13	48
406.11.27	BT 40	27	h6	40	21	13	58
406.11.32	BT 40	32	h6	50	24	23	78
406.11.40	BT 40	40	h6	50	27	23	88
406.11.16.1	BT 40	16	h6	100	17	73	38
406.11.22.1	BT 40	22	h6	100	19	73	48
406.11.27.1	BT 40	27	h6	100	21	73	58
406.11.32.1	BT 40	32	h6	100	24	73	78
406.11.40.1	BT 40	40	h6	100	27	73	88
406.11.16.2	BT 40	16	h6	160	17	133	38
406.11.22.2	BT 40	22	h6	160	19	133	48
406.11.27.2	BT 40	27	h6	160	21	133	58
406.11.32.2	BT 40	32	h6	160	24	133	78
406.11.40.2	BT 40	40	h6	160	27	133	88

* Form JD (AD)
* Form JD (AD)
* Form JD (AD)

BT 30 ohne Kühlkanalbohrungen an der Stirnseite
BT 30 without coolant exit bores on the end face
BT 30 sans alésages pour l'arrosage frontal

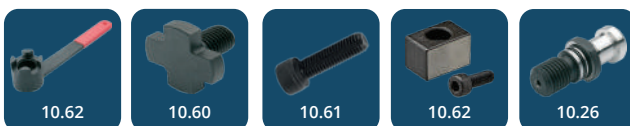

Shell mill holders DIN 6357 with enlarged contact face and coolant exit bores on the end face

Porte-fraises à trou lisse DIN 6357 avec face de contact élargie et conduits pour l'arrosage frontal



Verwendung:

Zur Aufnahme von Messerköpfen und Fräsern mit Quernut.

Application:

For mounting milling cutters with transversal groove.

Application:

Destiné à recevoir les fraises et les fraises avec des rainures transversales.

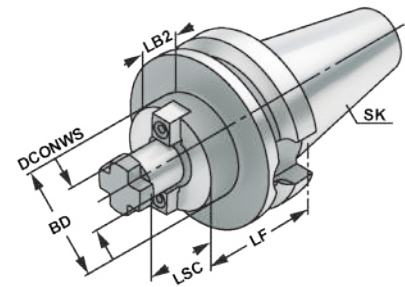

ISO 7388-2 Form JD/JF (AD/B) $\leq 5\mu\text{m}$ G2.5 25.000 min⁻¹ DIN 63587 h6

Bestell-Nr. Order no. Référence	SK	DCONWS	TDCON	LF	LSC	LB2	BD
506.11.22	BT 50	22	h6	40	19	2	48
506.11.27	BT 50	27	h6	40	21	2	58
506.11.32	BT 50	32	h6	50	24	12	78
506.11.40	BT 50	40	h6	50	27	12	88
506.11.60	BT 50	60	h6	80	40	42	129
506.11.22.1	BT 50	22	h6	100	19	62	48
506.11.27.1	BT 50	27	h6	100	21	62	58
506.11.32.1	BT 50	32	h6	100	24	62	78
506.11.40.1	BT 50	40	h6	100	27	62	88
506.11.22.2	BT 50	22	h6	160	19	122	48
506.11.27.2	BT 50	27	h6	160	21	122	58
506.11.32.2	BT 50	32	h6	160	24	122	78
506.11.40.2	BT 50	40	h6	160	27	122	88

DCONWS = 40 & 60 Für große Planfräser mit vier zusätzlichen Gewindebohrungen nach DIN 2079.
 For large diameter face mill cutters with four additional threaded holes according to DIN 2079.
 Pour fraises à surfacer à grands diamètres avec 4 taraudages supplémentaires suivant DIN 2079.

Lieferumfang: Mit Mitnehmersteinen, Kreuzschraube und Zylinderkopfschraube nach DIN 912 für Fräser mit innerer Kühlmittelzufuhr.

Delivery: With drivers, cross head retaining screw and cylinder head retaining screw for cutters with central coolant.
 For DCONWS = 60 only with four fixation screws according to DIN 912.

Livraison: Avec tenon d entraînement, vis cruciforme et vis à têtes cylindrique suivant DIN 912 pour les fraises avec arrosage central.
 Pour DCONWS = 60 est seulement avec quatre vis de fixation suivant DIN 912.

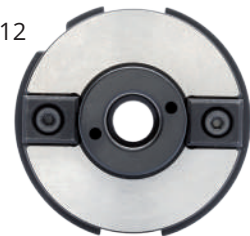

2



Verwendung:
Zur Aufnahme von Werkzeugen mit Zylinderschaft.

Application:
For mounting tools with straight shanks.

Application:
Pour le serrage d'outils avec queue cylindrique.

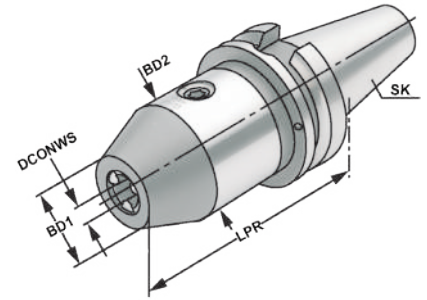

Bestell-Nr. Order no. Référence	SK	DCONWS Spannbereich Capacity Capacité	LPR	BD1	BD2	DRVS
305.15.08	BT 30	0 – 8	73	23	36	4
305.15.13	BT 30	1,0 – 13	93	31,0	50	6
305.15.16	BT 30	2,5 – 16	98	27,5	50	6
405.15.08	BT 40	0 – 8	78	23	36	4
405.15.13	BT 40	1,0 – 13	98	31,0	50	6
405.15.16	BT 40	2,5 – 16	103	27,5	50	6
505.15.13	BT 50	1,0 – 13	111	31,0	50	6
505.15.16	BT 50	2,5 – 16	113	27,5	50	6

Hinweis: Hohe Präzision und Rundlaufgenauigkeit von $\leq 0,03$ mm. Sichere Spannung des Werkzeuges durch mechanische Spannkraftverstärkung. Kein selbständiges Lösen der Spannung während der Bearbeitung bei Links- oder Rechtslauf, sowie bei Spindelstop. Spannen und Lösen mit Sechskantschlüssel.

Note: High precision and accurate concentricity of ≤ 0.03 mm. Secure gripping of the tool through mechanical amplification of the clamping force. No automatic slackening of the clamping force while machining with either clockwise or counter clockwise rotation or on spindle stop. Clamping and releasing effected by means of an Allen wrench.

Observation: Précision élevée et exactitude de circularité de $\leq 0,03$ mm. Serrage sûr de l'outil grâce à l'amplification de la force de serrage. Pas de desserrage intempestif en cours d'usinage lors de la rotation la gauche ou la droite, de même qu'en cas d'arrêt de la broche. Serrage et desserrage en utilisant un clé sur à fourche.

Lieferumfang: Ohne Spannschlüssel
Delivery: Without wrench
Livraison: Sans clé de serrage





Verwendung:
Zur Aufnahme von Werkzeugen mit Zylinderschaft.

Application:
For mounting tools with straight shanks.

Application:
Pour le serrage d'outils avec queue cylindrique.

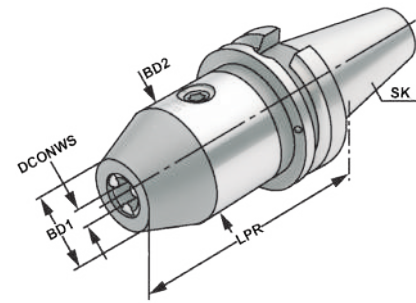

Bestell-Nr. Order no. Référence	SK	DCONWS Spannbereich Capacity Capacité	LPR	BD1	BD2	DRVS
406.15.08	BT 40	0 - 8	78	23	36	4
406.15.13	BT 40	1,0 - 13	98	31,0	50	6
406.15.16	BT 40	2,5 - 16	103	27,5	50	6
506.15.13	BT 50	1,0 - 13	111	31,0	50	6
506.15.16	BT 50	2,5 - 16	113	27,5	50	6

Hinweis: Hohe Präzision und Rundlaufgenauigkeit von $\leq 0,03$ mm. Sichere Spannung des Werkzeuges durch mechanische Spannkraftverstärkung. Kein selbständiges Lösen der Spannung während der Bearbeitung bei Links- oder Rechtslauf, sowie bei Spindelstop. Spannen und Lösen mit Sechskantschlüssel.

Note: High precision and accurate concentricity of ≤ 0.03 mm. Secure gripping of the tool through mechanical amplification of the clamping force. No automatic slackening of the clamping force while machining with either clockwise or counter clockwise rotation or on spindle stop. Clamping and releasing effected by means of an Allen wrench.

Observation: Précision élevée et exactitude de circularité de $\leq 0,03$ mm. Serrage sûr de l'outil grâce à l'amplification de la force de serrage. Pas de desserrage intempestif en cours d'usinage lors de la rotation la gauche ou la droite, de même qu'en cas d'arrêt de la broche. Serrage et desserrage en utilisant un clé sur à fourche.

Lieferumfang: Ohne Spannschlüssel
Delivery: Without wrench
Livraison: Sans clé de serrage





Quick change tapping chucks **with** length compensation on compression and expansion

Mandrins de taraudage à changement rapide **avec** compensation longitudinale à la compression et traction

2



Verwendung:

Zur Aufnahme von Schnellwechsel-Ein-sätzen für Gewindebohrer.

Application:

For the chucking of quick change adaptors for taps.

Application:

Pour le serrage d'adaptateurs porte-tarands à changement rapide.

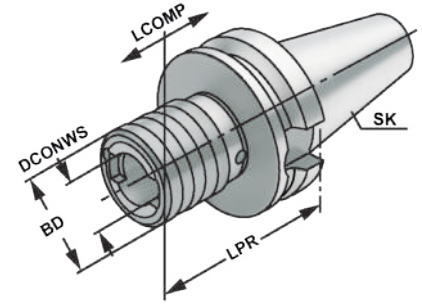

Bestell-Nr. Order no. Référence	SK	Spannbereich Capacity Capacité	SZID	DCONWS	LPR	BD	LCOMP
305.16.12	BT 30	M3 - M14	1	19	64	36	7
305.16.20	BT 30	M5 - M22	2	31	95	53	12
405.16.12	BT 40	M3 - M14	1	19	65	36	7
405.16.20	BT 40	M5 - M22	2	31	93	53	12
405.16.36	BT 40	M14 - M36	3	48	166	78	20
505.16.12	BT 50	M3 - M14	1	19	100	36	7
505.16.20	BT 50	M5 - M22	2	31	105	53	12
505.16.36	BT 50	M14 - M36	3	48	142	78	17,5

Hinweis: Für Bearbeitungszentren ohne Synchronspindel.
Note: For machining centres without synchronous spindle.
Observation: Pour centres d'usinage sans broche synchrone.



ohne Längenausgleich auf Druck und Zug

(JIS B 6339)

Quick change tapping chucks **without** length compensation on compression and expansion

Mandrins de taraudage à changement rapide **sans** compensation longitudinale à la compression et traction



Verwendung:
Zur Aufnahme von Schnellwechsel-Einsätzen für Gewindebohrer.

Application:
For the chucking of quick change adaptors for taps.

Application:
Pour le serrage d'adapteurs portetarauds à changement rapide.

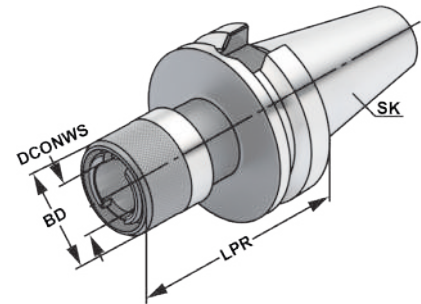

2

ISO 7388-2

Form JD (AD)

13.04

Bestell-Nr. Order no. Référence	SK	Spannbereich Capacity Capacité	SZID	DCONWS	LPR	BD
305.16.12.1	BT 30	M3 – M14	1	19	66	38
305.16.20.1	BT 30	M5 – M22	2	31	80	54
405.16.12.1	BT 40	M3 – M14	1	19	72	38
405.16.20.1	BT 40	M5 – M22	2	31	93	54
405.16.36.1	BT 40	M14 – M36	3	48	130	78
505.16.12.1	BT 50	M3 – M14	1	19	80	38
505.16.20.1	BT 50	M5 – M22	2	31	95	54
505.16.36.1	BT 50	M14 – M36	3	48	142	78

Hinweis: Für Bearbeitungszentren mit Synchronspindel.
Note: For machining centres with synchronous spindle.
Observation: Pour centres d'usinage avec broche synchrone.





Tapping chucks for synchronisation for collets DIN 6499 (ISO 15488) ER-system

Mandrins de taraudage pour synchronisation pour pinces DIN 6499 (ISO 15488) système ER

2



Verwendung:

Für Bearbeitungszentren mit Synchronspindel.

Application:

For machining centres with synchronous spindle.

Application:

Pour centres d'usinage avec broche synchrone.

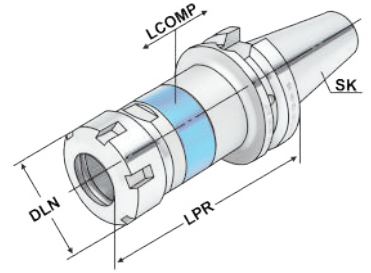

Bestell-Nr. Order no. Référence	SK	DCONWS Spannbereich Capacity Capacité	Typ	LPR	DLN	LCOMP
406.16.02.10*	BT 40	M3 – M12	426E ER 16 SW25	81	28	0,5
406.16.02.13	BT 40	M3 – M16	428E ER 20	85	34	0,5
406.16.02.16	BT 40	M3 – M20	430E ER 25	89	42	0,5
406.16.02.20	BT 40	M3 – M27	470E ER 32	110	50	0,5
406.16.02.26	BT 40	M3 – M33	472E ER 40	115	63	0,5
506.16.02.10*	BT 50	M3 – M12	426E ER 16 SW25	95	28	0,5
506.16.02.13	BT 50	M3 – M16	428E ER 20	100	34	0,5
506.16.02.16	BT 50	M3 – M20	430E ER 25	110	42	0,5
506.16.02.20	BT 50	M3 – M27	470E ER 32	120	50	0,5
506.16.02.26	BT 50	M3 – M33	472E ER 40	120	63	0,5

*** Sechskantmutter**

* Hexagonal clamping nut

* Écrous hexagonal

Hinweis:

- Synchro-Gewindeschneidfutter kompensieren Synchronisationsfehler.
- Minimallängenausgleich in Druck- und Zugrichtung zwischen Synchronspindel und Gewindebohrer reduziert zu hohe Gewindeflankenreibungskräfte.
- Reduziert eventuelle Axialkraftherhöhung während des Schneidzyklus auf ein Minimum.
- Geeignet für Innenkühlung.
- Kühlmitteldruck max. 100 bar.

Note:

- Synchro tapping chucks compensate synchronisation errors.
- Minimal length compensation on compression and expansion balances very small pitch differences between synchro spindle and tap, which can cause high frictional forces on the thread flanks.
- A possible increase of axial force during the tapping process is reduced to a minimum.
- Suitable for internal coolant.
- Coolant pressure up to max. 100 bar.

Observation:

- Mandrins de taraudage version „synchro“ compensent les erreurs éventuelles de synchronisation.
- Compensation longitudinale minimale à la compression et traction entre la broche synchronisée et le taraud réduit la friction au niveau des flancs de filets.
- Réduit au minimum les efforts éventuelles axiaux lors du cycle de taraudage.
- Approprié pour la lubrification centrale.
- Pression de lubrification max. 100 bar.

Lieferumfang:

Mit gewuchteter Spannmutter

Delivery:

With balanced clamping nut

Livraison:

Avec écrou de serrage équilibré

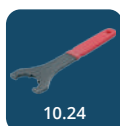



Verwendung:
Zur Aufnahme von Bohrfuttern.
Application:
For mounting drill chucks.
Application:
Pour le serrage de mandrins de perçage.

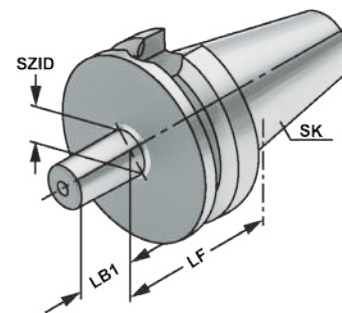

ISO 7388-2	Form J (A)	≤ 5µm	G6.3 15.000 min ⁻¹	DIN 238	AT4
------------	------------	-------	-------------------------------	---------	-----

Bestell-Nr. Order no. Référence	SK	SZID	LF	LB1
305.14.12	BT 30	B12	25	18,5
305.14.16	BT 30	B16	25	24
405.14.12	BT 40	B12	25	18,5
405.14.16	BT 40	B16	25	24
405.14.18	BT 40	B18	32	32
505.14.16	BT 50	B16	32	24
505.14.18	BT 50	B18	32	32



2



Verwendung:
Zur Aufnahme von Einschraubfräser mit Gewinde.

Application:
For mounting screw-in cutters with thread.

Application:
Pour le serrage de fraises à queue fileté.

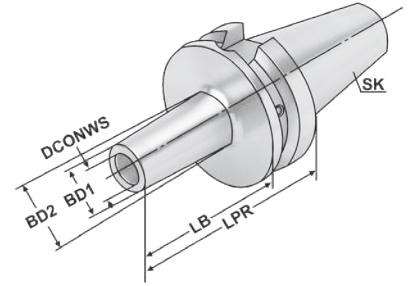

ISO
7388-2

Form
JD/JF
(AD/B)

$\leq 3\mu\text{m}$

$G2.5$
 25.000
 min^{-1}

H7

Bestell-Nr. Order no. Référence	SK	THSZWS	DCONWS	BD1	BD2	LPR	LB
406.06.06	BT 40	M6	6,5	10	13	52	25
406.06.06.1	BT 40	M6	6,5	10	20	77	50
406.06.06.2	BT 40	M6	6,5	10	23	102	75
406.06.08	BT 40	M8	8,5	13	15	52	25
406.06.08.1	BT 40	M8	8,5	13	23	77	50
406.06.08.2	BT 40	M8	8,5	13	23	102	75
406.06.08.3	BT 40	M8	8,5	13	25	127	100
406.06.10	BT 40	M10	10,5	18	20	52	25
406.06.10.1	BT 40	M10	10,5	18	23	77	50
406.06.10.2	BT 40	M10	10,5	18	28	102	75
406.06.10.3	BT 40	M10	10,5	18	32	127	100
406.06.12	BT 40	M12	12,5	21	24	52	25
406.06.12.1	BT 40	M12	12,5	21	24	77	50
406.06.12.2	BT 40	M12	12,5	21	31	102	75
406.06.12.3	BT 40	M12	12,5	21	33	127	100
406.06.12.4	BT 40	M12	12,5	21	36	152	125
406.06.16	BT 40	M16	17	29	29	52	25
406.06.16.1	BT 40	M16	17	29	34	77	50
406.06.16.2	BT 40	M16	17	29	34	102	75
406.06.16.3	BT 40	M16	17	29	36	127	100
406.06.16.4	BT 40	M16	17	29	40	152	125
406.06.16.5	BT 40	M16	17	29	42	177	150
506.06.08.1	BT 50	M8	8,5	13	23	88	50
506.06.08.3	BT 50	M8	8,5	13	25	138	100
506.06.08.5	BT 50	M8	8,5	13	30	188	150
506.06.10.1	BT 50	M10	10,5	18	23	88	50
506.06.10.3	BT 50	M10	10,5	18	32	138	100
506.06.10.5	BT 50	M10	10,5	18	37	188	150
506.06.12.1	BT 50	M12	12,5	21	24	88	50
506.06.12.3	BT 50	M12	12,5	21	33	138	100
506.06.12.5	BT 50	M12	12,5	21	40	188	150
506.06.16.1	BT 50	M16	17	29	34	88	50
506.06.16.2	BT 50	M16	17	29	36	113	75
506.06.16.3	BT 50	M16	17	29	36	138	100
506.06.16.5	BT 50	M16	17	29	43	188	150

Test arbors
Mandrins de contrôle



Verwendung:
Zur Abnahme von Werkzeugmaschinen gemäß ISO-Empfehlung R230 oder zur Überprüfung der Werkzeugspindel.

Application:
For the inspection of machine tools according to ISO recommendation R230 or for testing the tool spindle.

Application:
Pour l'inspection de machine-outils suite à la recommandation ISO R230 ou pour la vérification de la broche.

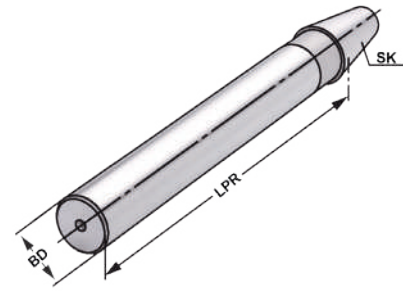

ISO 7388-2 Form J (A) ≤ 3µm

Bestell-Nr. Order no. Référence	SK	LPR	BD	Toleranz Tolerance Tolérance	max. Rundlaufabweichung max. concentricity deviation Faux-rond max.
305.18.32	BT 30	300	32	0,003	0,003
405.18.40	BT 40	300	40	0,003	0,003
505.18.50	BT 50	300	50	0,003	0,003

Lieferumfang: Auslieferung mit Prüfprotokoll
Delivery: *Delivery with test certificate*
Livraison: Livraison avec rapport d essais

Holzkasten für Kontrolldorne

Wooden box for test arbors
Coffret en bois pour mandrins de contrôle



Verwendung:
Zur Aufbewahrung von Kontrolldornen.

Application:
For the storage of test arbors.

Application:
Pour la conservation de mandrins de contrôle.



Bestell-Nr. Order no. Référence	Abmessung Size Dimension	für Kegelgrößen for cones pour cônes
701.18	460 × 130 × 115	BT 30 / 40 / 50



2



Verwendung:
Zur Herstellung von Sonderwerkzeugen.
Application:
For the manufacturing of special tools.
Application:
Pour la fabrication d'outils spéciaux.

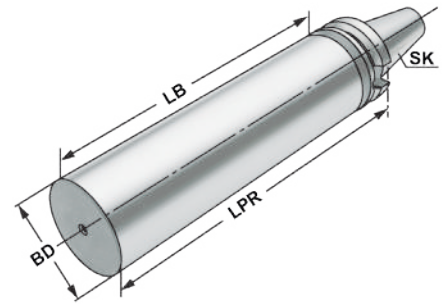

ISO
7388-2

Form
J
(A)

Bestell-Nr. Order no. Référence	SK	BD	LB	LPR
305.17.40	BT 30	40,5	138	160
405.17.63	BT 40	63	215	250
505.17.97	BT 50	97	277	315

Ausführung: Steilkegel und Bund gehärtet und geschliffen. Schaft weich zur weiteren Bearbeitung.
Version: Cone and flange hardened and grinded. Soft body for later processing.
Version: Cône et collerette durcis et rectifiés. Corps doux pour un usinage ultérieur.



Reparatur und Wartung für Hydro-Dehnspannfutter

Die Hydro-Dehnspanntechnik ist eine weltweit verbreitete, bewährte und zuverlässige Methode zur Aufnahme von Werkzeugen. Dank ihrer konstruktiven Vorteile ist sie unempfindlich, wartungsarm und langlebig. Dennoch kommt es durch thermische und mechanische Belastung im Werkstattgebrauch im Laufe der Zeit zu Spannkraftverlusten. Die Folge sind schlechtere Werkzeugstandzeiten und Qualitätseinbußen bei der Bearbeitung bis hin zum teuren Werkzeugbruch.

Wir warten und reparieren Ihre Hydro-Dehnspannfutter - egal ob von uns oder ein Fremdfabrikat - kostengünstig hier bei uns in Süd-Deutschland.

Hier prüfen wir die Ursachen für den Spannkraftverlust und reparieren innerhalb von zwei Wochen zu einem günstigen Festpreis. Wir erneuern dabei alle Verschleißteile, befüllen das Hydrauliksystem neu und justieren das Hydrauliksystem auf den korrekten Spanndruck. Abschließend erfolgt eine Endprüfung.

Kontaktieren Sie unseren Kundenservice für weitere Informationen und Preise.

Maintenance and repair of hydraulic chucks

Clamping of tools with hydraulic chucks is a widespread, well-established and reliable method.

It is a resistant, easy-to-operate and durable way of clamping due to its advantageous construction design.

Nevertheless in the course of time under the influence of thermal and mechanical outputs at factories loss of clamping force is observed. As a result the life of the tool shortens and its quality during the working process reduces. Therefore it leads to a costly damage of the tool.

We maintain and repair your hydraulic chucks - both those manufactured at our place and those produced somewhere else - for a reasonable price here at our office in the south of Germany.

We check possible causes of the clamping force reduction and repair it within two weeks at a fixed low price. At the same time we renew all the fast wearing parts, fill the hydraulic system anew and adjust its clamping force. Afterwards the final inspection stage takes place.

You are welcome to contact our customer service for further information and prices.

La réparation et la maintenance des mandrins hydrauliques

L'accueil des outils à l'aide d'un mandrin hydraulique est une technique éprouvée, répandue à l'échelle mondiale et de confiance.

Grâce à sa construction avantageuse elle est robuste, facile à entretenir et durable.

Pourtant à cause de la charge thermique et mécanique imposés sur les mandrins lors du travail la tension du ressort diminue au fil du temps. Par conséquent la résistance des outils coupants se détériore et la qualité lors d'usinage se réduit. En retour cela conduit à la rupture coûteuse d'outil.

On entretient et répare vos mandrins hydrauliques - peu importe l'issue de notre production ou d'ailleurs - bon marché et ici chez nous au sud de l'Allemagne.

Tout d'abord nos spécialistes cherchent la cause de la perte de la tension du ressort, ensuite ils effectuent la réparation sous 2 semaines pour le prix fixe et favorable. En outre ils renouvellent toutes les pièces d'usure, remplissent le système hydraulique à nouveau et ajustent la tension correcte. À la fin l'inspection finale se déroule.

Contactez notre centre de service client pour obtenir l'information supplémentaire ainsi que l'information actuelle sur le prix.



2



Verwendung:
Zur Aufnahme von Werkzeugen mit Zylinderschaft. Besonders im Werkzeug- und Formenbau wo reduzierte Störkontur gefordert ist.

Application:
For mounting straight-shank tools. Especially in operations in toolmaking and mould making. Wherever reduced interference contours are required.

Application:
Pour le serrage d'outils avec queue cylindrique. Particulièrement dans la fabrication d'outils et de moules. Applications nécessitant un encombrement réduit.

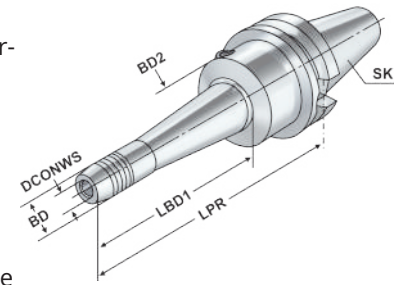

Bestell-Nr. Order no. Référence	SK	DCONWS	LPR	BD	BD2	LSCX	ADJRGA	LBD1	DRVS	THID
406.HSL06.160	BT 40	6	160	16	50	37	10	103	5	M6x1
406.HSL08.160	BT 40	8	160	18	50	37	10	103	5	M6x1
406.HSL10.160	BT 40	10	160	20	50	42	10	103	5	M8x1
406.HSL12.160	BT 40	12	160	22	50	47	10	103	5	M8x1

LSCX = Einspannlänge, max. ADJRGA = Verstellweg, max.
LSCX = Clamping depth, max. ADJRGA = Length adjustment range, max.
LSCX = Profondeur d'insertion, max. ADJRGA = Course de réglage, max.

Lieferumfang: Ohne Spannschlüssel
Delivery: Without wrench
Livraison: Sans clé de serrage



Spannkraft-Prüfgerät für Hydrodehnspannfutter - Seite 12.59
Clamping force proofing instrument for hydraulic chucks - page 12.59
Appareil de contrôle des forces de serrage pour mandrin expansibles hydrauliques - page 12.59





Verwendung:

Zur Aufnahme von Werkzeugen mit Zylinderschaft nach DIN 1835 Form A+B+E und DIN 6535 Form HB+HE (größer Ø 20 mm nur mit Reduzierung).

Application:

For mounting straight-shank tools acc. DIN 1835 form A+B+E and DIN 6535 form HB+HE (larger than Ø 20 mm only with reduction sleeve).

Application:

Pour le serrage d'outils avec queue cylindrique suivant DIN 1835 forme A+B+E et DIN 6535 forme HB+HE (à partir de Ø 20 mm seulement avec réduction).

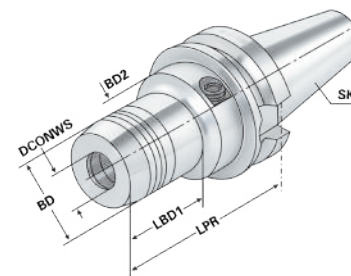

Bestell-Nr. Order no. Référence	SK	DCONWS	LPR	BD	BD2	LSCX	ADJRGA	LBD1	DRVS	THID
305.H06*	BT 30	6	60	26	45	37	10	33	5	M6x1
305.H08*	BT 30	8	64	28	45	37	10	29	5	M6x1
305.H10*	BT 30	10	64	30	45	42	10	37	5	M6x1
305.H12*	BT 30	12	72	32	45	47	10	43	5	M8x1
305.H14*	BT 30	14	70	34	45	47	10	41	5	M10x1
305.H16*	BT 30	16	90	38	45	52	10	52	5	M12x1
305.H18*	BT 30	18	90	40	45	52	10	52	5	M12x1
305.H20*	BT 30	20	90	42	45	52	10	52	5	M12x1
405.H06	BT 40	6	90	26	50	37	10	43	5	M6x1
405.H08	BT 40	8	90	28	50	37	10	43,5	5	M6x1
405.H10	BT 40	10	90	30	50	42	10	44	5	M8x1
405.H12	BT 40	12	90	32	50	47	10	44,5	5	M8x1
405.H14	BT 40	14	90	34	50	47	10	47,5	5	M10x1
405.H16	BT 40	16	90	38	50	52	10	47,5	5	M12x1
405.H18	BT 40	18	90	40	50	52	10	47,5	5	M12x1
405.H20	BT 40	20	90	42	50	52	10	47,5	5	M12x1
405.H25	BT 40	25	90	50	50	58	10	63	6	M8x1
405.H32	BT 40	32	110	60	60	62	10	83	6	M12x1
405.H06.1	BT 40	6	150	26	50	37	10	102	5	M6x1
405.H08.1	BT 40	8	150	28	50	37	10	103	5	M6x1
405.H10.1	BT 40	10	150	30	50	42	10	104	5	M8x1
405.H12.1	BT 40	12	150	32	50	47	10	105	5	M8x1
405.H14.1	BT 40	14	150	34	50	47	10	105	5	M10x1
405.H16.1	BT 40	16	150	38	50	52	10	106	5	M12x1
405.H18.1	BT 40	18	150	40	50	52	10	107	5	M12x1
405.H20.1	BT 40	20	150	42	50	52	10	108	5	M12x1
405.H25.1	BT 40	25	150	50	50	58	10	123	6	M12x1
405.H32.1	BT 40	32	150	60	60	64	10	123	6	M12x1

* Form JD (AD)

* Form JD (AD)

* Form JD (AD)

LSCX = Einspannlänge, max.

LSCX = Clamping depth, max.

LSCX = Profondeur d'insertion, max.

ADJRGA = Verstellweg, max.

ADJRGA = Length adjustment range, max.

ADJRGA = Course de réglage, max.

Lieferumfang: Ohne Spannschlüssel

Delivery: Without wrench

Livraison: Sans clé de serrage



2



Verwendung:

Zur Aufnahme von Werkzeugen mit Zylinderschaft nach DIN 1835 Form A+B+E und DIN 6535 Form HB+HE (größer Ø 20 mm nur mit Reduzierung).

Application:

For mounting straight-shank tools acc. DIN 1835 form A+B+E and DIN 6535 form HB+HE (larger than Ø 20 mm only with reduction sleeve).

Application:

Pour le serrage d'outils avec queue cylindrique suivant DIN 1835 forme A+B+E et DIN 6535 forme HB+HE (à partir de Ø 20 mm seulement avec réduction).

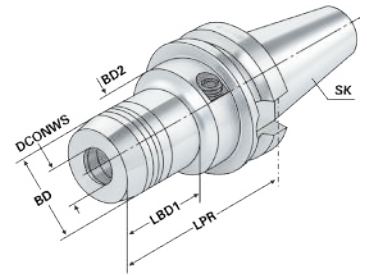

Bestell-Nr. Order no. Référence	SK	DCONWS	LPR	BD	BD2	LSCX	ADJRGA	LBD1	DRVS	THID
405.H06.2	BT 40	6	200	26	50	37	10	152	5	M6x1
405.H08.2	BT 40	8	200	28	50	37	10	153	5	M6x1
405.H10.2	BT 40	10	200	30	50	42	10	154	5	M8x1
405.H12.2	BT 40	12	200	32	50	47	10	155	5	M8x1
405.H14.2	BT 40	14	200	34	50	47	10	155	5	M10x1
405.H16.2	BT 40	16	200	38	50	52	10	156	5	M12x1
405.H18.2	BT 40	18	200	40	50	52	10	157	5	M12x1
405.H20.2	BT 40	20	200	42	50	52	10	158	5	M12x1
405.H25.2	BT 40	25	200	50	50	58	10	173	6	M12x1
405.H32.2	BT 40	32	200	60	50	62	10	173	6	M12x1
505.H06	BT 50	6	110	26	80	37	10	43	5	M6x1
505.H08	BT 50	8	110	28	80	37	10	43,5	5	M6x1
505.H10	BT 50	10	110	30	80	42	10	44	5	M8x1
505.H12	BT 50	12	110	32	80	47	10	42	5	M8x1
505.H14	BT 50	14	110	34	80	47	10	42	5	M10x1
505.H16	BT 50	16	110	38	80	52	10	45	5	M12x1
505.H18	BT 50	18	110	40	80	52	10	47,5	5	M12x1
505.H20	BT 50	20	110	42	80	52	10	47,5	5	M12x1
505.H25	BT 50	25	110	50	80	58	10	47,5	6	M16x1
505.H32	BT 50	32	110	60	80	62	10	47,5	6	M16x1

LSCX = Einspannlänge, max.
LSCX = Clamping depth, max.
LSCX = Profondeur d'insertion, max.

ADJRGA = Verstellweg, max.
ADJRGA = Length adjustment range, max.
ADJRGA = Course de réglage, max.

Lieferumfang: Ohne Spannschlüssel
Delivery: Without wrench
Livraison: Sans clé de serrage

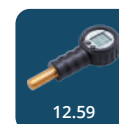
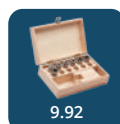

Shrink chucks 3° for mounting of solid carbide and HSS-tool shanks - slim

Mandrins de frettage 3° pour le serrage de queues d'outils carbures de type HM et HSS - élané



Verwendung:
Zur Aufnahme von Werkzeugen mit Zylinderschaft.

Application:
For mounting straight-shank tools.

Application:
Pour le serrage d'outils avec queue cylindrique.

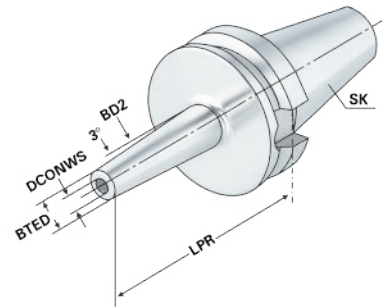

Bestell-Nr. Order no. Référence	SK	DCONWS	TDCON	LPR	BTED	BD2	LSCX	LSCN	ADJRGA	THID
406.72.03	BT 40	3	h4	90	9	15,5	-	6	-	-
406.72.04	BT 40	4	h4	90	10	16,5	-	8	-	-
406.72.05	BT 40	5	h4	90	11	17,5	-	10	-	-
406.72.06	BT 40	6	h6	90	12	18,5	36	22	10	M5x0,8
406.72.08	BT 40	8	h6	90	14	20,5	36	26	10	M6x1
406.72.10	BT 40	10	h6	90	16	22,5	41	31	10	M8x1
406.72.12	BT 40	12	h6	90	18	24,5	46	36	10	M10x1
406.72.03.1	BT 40	3	h4	120	9	19,5	-	6	-	-
406.72.04.1	BT 40	4	h4	120	10	20,5	-	8	-	-
406.72.05.1	BT 40	5	h4	120	11	21,5	-	10	-	-
406.72.06.1	BT 40	6	h6	120	12	22,5	36	22	10	M5x0,8
406.72.08.1	BT 40	8	h6	120	14	24,5	36	26	10	M6x1
406.72.10.1	BT 40	10	h6	120	16	26,5	41	31	10	M8x1
406.72.12.1	BT 40	12	h6	120	18	28,5	46	36	10	M10x1
406.72.06.2	BT 40	6	h6	160	12	26,5	36	22	10	M5x0,8
406.72.08.2	BT 40	8	h6	160	14	28,5	36	26	10	M6x1
406.72.10.2	BT 40	10	h6	160	16	30,5	41	31	10	M8x1
406.72.12.2	BT 40	12	h6	160	18	32,5	46	36	10	M10x1

LSCX = Einspannlänge, max. ADJRGA = Verstellweg, max.
 LSCX = Clamping depth, max. ADJRGA = Length adjustment range, max.
 LSCX = Profondeur d'insertion, max. ADJRGA = Course de réglage, max.

Ausführung: schlanke Bauform (reduzierte Störkontur)
Version: slim design (reduced interference contour)
Version: Modèle très étroit (encombrement réduit)

Für Ø 3, 4 und 5 mm nur Hartmetallschäfte verwenden
 For Ø 3, 4 and 5 mm only solid carbide tool shanks must be used
 Pour Ø 3, 4 et 5 mm il faut seulement utiliser de queues d'outils carbures de type HM

Hinweis: Aufnahmen für Induktiv-, Kontakt- und Heißluftschrimpferäte geeignet.
 Schafttoleranz bei Ø 3, 4 und 5 mm = h4, bei Ø 6 - Ø 12 mm = h6

Note: Toolholders suitable for induction-, contact- and hot air shrink units.
 Ø 3, 4, 5 with h4-tolerance and Ø 6 - Ø 12 with h6-tolerance

Observation: Porte-outils convenables pour machines à fretter par induction,
 par contact, ou par air chaud.
 Ø 3, 4, 5 avec h4-tolerance et Ø 6 - Ø 12 avec h6-tolerance





Shrink chucks 4,5° for mounting of solid carbide and HSS-tool shanks

Mandrins de frettage 4,5° pour le serrage de queues d'outils carbures de type HM et HSS

2

**Verwendung:**

Zur Aufnahme von Werkzeugen mit Zylinderschaft.

Application:

For mounting straight-shank tools.

Application:

Pour le serrage d'outils avec queue cylindrique.

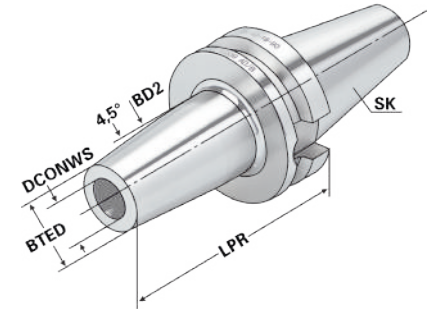

Bestell-Nr. Order no. Référence	SK	DCONWS	TDCON	LPR	BTED	BD2	LSCN	LSCX	ADJRGA	THID
305.70.03*	BT 30	3	h4	80	15	20	6	-	-	-
305.70.04*	BT 30	4	h4	80	15	20	8	-	-	-
305.70.05*	BT 30	5	h4	80	15	20	10	-	-	-
305.70.06*	BT 30	6	h6	80	21	27	22	36	10	M5x0,8
305.70.08*	BT 30	8	h6	80	21	27	26	36	10	M6x1
305.70.10*	BT 30	10	h6	90	24	32	31	41	10	M8x1
305.70.12*	BT 30	12	h6	90	24	32	36	46	10	M10x1
305.70.14*	BT 30	14	h6	90	27	34	36	46	10	M10x1
305.70.16*	BT 30	16	h6	90	27	34	39	49	10	M12x1
305.70.18*	BT 30	18	h6	90	33	42	39	49	10	M12x1
305.70.20*	BT 30	20	h6	90	33	42	41	51	10	M16x1
305.70.25*	BT 30	25	h6	100	44	53	47	57	10	M16x1
406.70.03	BT 40	3	h4	80	11	15	6	-	-	-
406.70.04	BT 40	4	h4	80	14	22	8	-	-	-
406.70.05	BT 40	5	h4	80	16	22	10	-	-	-
406.70.06	BT 40	6	h6	90	21	27	22	36	10	M5x0,8
406.70.08	BT 40	8	h6	90	21	27	26	36	10	M6x1
406.70.10	BT 40	10	h6	90	24	32	31	41	10	M8x1
406.70.12	BT 40	12	h6	90	24	32	36	46	10	M10x1
406.70.14	BT 40	14	h6	90	27	34	36	46	10	M10x1
406.70.16	BT 40	16	h6	90	27	34	39	49	10	M12x1
406.70.18	BT 40	18	h6	90	33	42	39	49	10	M12x1
406.70.20	BT 40	20	h6	90	33	42	41	51	10	M16x1
406.70.25	BT 40	25	h6	100	44	53	47	57	10	M16x1
406.70.32	BT 40	32	h6	100	44	53	51	61	10	M16x1

* Form JD/AD

* Form JD/AD

* Form JD/AD

LSCX = Einspannlänge, max.

LSCX = Clamping depth, max.

LSCX = Profondeur d'insertion, max.

ADJRGA = Verstellweg, max.

ADJRGA = Length adjustment range, max.

ADJRGA = Course de réglage, max.

Für Ø 3, 4 und 5 mm nur Hartmetallschäfte verwenden!

For Ø 3, 4 and 5 mm only solid carbide tool shanks must be used!

Pour Ø 3, 4 et 5 mm il faut seulement utiliser de queues d'outils carbures de type HM!

Hinweis:Aufnahme für Induktiv-, Kontakt- und Heißluftschumpfgeräte geeignet.
Schafttoleranz bei Ø 3, 4 und 5 mm = h₄, bei Ø 6 – Ø 32 mm = h₆**Note:**Toolholders suitable for induction-, contact- and hot air shrink units.
Ø 3, 4, 5 with h₄-tolerance and Ø 6 – Ø 32 with h₆-tolerance**Observation:**Porte-outils convenables pour machines à fretter par induction,
par contact, ou par air chaud.
Ø 3, 4, 5 avec h₄-tolerance et Ø 6 – Ø 32 avec h₆-tolerance

Shrink chucks 4,5° for mounting of solid carbide and HSS-tool shanks

Mandrins de frettage 4,5° pour le serrage de queues d'outils carbures de type HM et HSS



Verwendung:
Zur Aufnahme von Werkzeugen mit Zylinderschaft.

Application:
For mounting straight-shank tools.

Application:
Pour le serrage d'outils avec queue cylindrique.

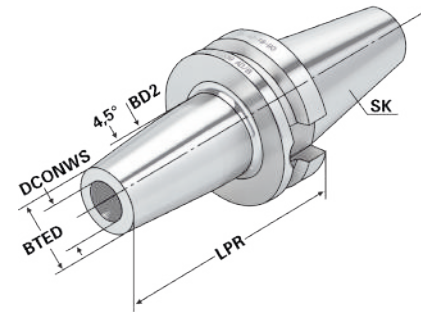

ISO 7388-2 Form JD/JF (AD/B) ≤ 3µm G2.5 25.000 min⁻¹ h6

Bestell-Nr. Order no. Référence	SK	DCONWS	TDCON	LPR	BTED	BD2	LSCN	LSCX	ADJRGA	THID
406.70.06.1	BT 40	6	h6	120	21	27	22	36	10	M5x0,8
406.70.08.1	BT 40	8	h6	120	21	27	26	36	10	M6x1
406.70.10.1	BT 40	10	h6	120	24	32	31	41	10	M8x1
406.70.12.1	BT 40	12	h6	120	24	32	36	46	10	M10x1
406.70.14.1	BT 40	14	h6	120	27	34	36	46	10	M10x1
406.70.16.1	BT 40	16	h6	120	27	34	39	49	10	M12x1
406.70.18.1	BT 40	18	h6	120	33	42	39	49	10	M12x1
406.70.20.1	BT 40	20	h6	120	33	42	41	51	10	M16x1
406.70.06.2	BT 40	6	h6	160	21	27	22	36	10	M5x0,8
406.70.08.2	BT 40	8	h6	160	21	27	26	36	10	M6x1
406.70.10.2	BT 40	10	h6	160	24	32	31	41	10	M8x1
406.70.12.2	BT 40	12	h6	160	24	32	36	46	10	M10x1
406.70.14.2	BT 40	14	h6	160	27	34	36	46	10	M10x1
406.70.16.2	BT 40	16	h6	160	27	34	39	49	10	M12x1
406.70.18.2	BT 40	18	h6	160	33	42	39	49	10	M12x1
406.70.20.2	BT 40	20	h6	160	33	42	41	51	10	M16x1
406.70.25.2	BT 40	25	h6	160	44	53	47	57	10	M16x1
406.70.32.2	BT 40	32	h6	160	44	62	51	61	10	M16x1

LSCX = Einspannlänge, max. ADJRGA = Verstellweg, max.
LSCX = Clamping depth, max. ADJRGA = Length adjustment range, max.
LSCX = Profondeur d'insertion, max. ADJRGA = Course de réglage, max.

Hinweis: Aufnahme für Induktiv-, Kontakt- und Heißluftschumpfergeräte geeignet. Schafttoleranz bei Ø 6 - Ø 32 mm = h₆

Note: Toolholders suitable for induction-, contact- and hot air shrink units. Ø 6 - Ø 32 with h₆-tolerance

Observation: Porte-outils convenables pour machines à fretter par induction, par contact, ou par air chaud. Ø 6 - Ø 32 avec h₆-tolerance





Shrink chucks 4,5° for mounting of solid carbide and HSS-tool shanks

Mandrins de frettage 4,5° pour le serrage de queues d'outils carbures de type HM et HSS

2



Verwendung:
Zur Aufnahme von Werkzeugen mit Zylinderschaft.

Application:
For mounting straight-shank tools.

Application:
Pour le serrage d'outils avec queue cylindrique.

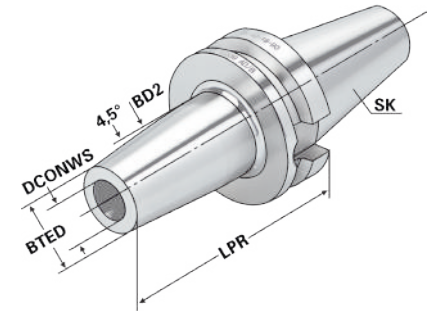

Bestell-Nr. Order no. Référence	SK	DCONWS	TDCON	LPR	BTED	BD2	LSCN	LSCX	ADJRGA	THID
506.71.04	BT 50	4	h4	100	15	20	8	-	-	-
506.71.05	BT 50	5	h4	100	15	20	10	-	-	-
506.71.06	BT 50	6	h6	100	21	27	22	36	10	M5x0,8
506.71.08	BT 50	8	h6	100	21	27	26	36	10	M6x1
506.71.10	BT 50	10	h6	100	24	32	31	41	10	M8x1
506.71.12	BT 50	12	h6	100	24	32	36	46	10	M10x1
506.71.14	BT 50	14	h6	100	27	34	36	46	10	M10x1
506.71.16	BT 50	16	h6	100	27	34	39	49	10	M12x1
506.71.18	BT 50	18	h6	110	33	42	39	49	10	M12x1
506.71.20	BT 50	20	h6	110	33	42	41	51	10	M16x1
506.71.25	BT 50	25	h6	120	44	53	47	57	10	M16x1
506.71.32	BT 50	32	h6	120	44	53	51	61	10	M16x1
506.71.06.1	BT 50	6	h6	120	21	27	22	36	10	M5x0,8
506.71.08.1	BT 50	8	h6	120	21	27	26	36	10	M6x1
506.71.10.1	BT 50	10	h6	120	24	32	31	41	10	M8x1
506.71.12.1	BT 50	12	h6	120	24	32	36	46	10	M10x1
506.71.14.1	BT 50	14	h6	120	27	34	36	46	10	M10x1
506.71.16.1	BT 50	16	h6	120	27	34	39	49	10	M12x1
506.71.18.1	BT 50	18	h6	120	33	42	39	49	10	M12x1
506.71.20.1	BT 50	20	h6	120	33	42	41	51	10	M16x1

LSCX = Einspannlänge, max.
LSCX = Clamping depth, max.
LSCX = Profondeur d'insertion, max.

ADJRGA = Verstellweg, max.
ADJRGA = Length adjustment range, max.
ADJRGA = Course de réglage, max.

Hinweis: Aufnahme für Induktiv-, Kontakt- und Heißluftschumpfgeräte geeignet.
Schafttoleranz bei $\varnothing 6 - \varnothing 32$ mm = h₆

Note: Toolholders suitable for induction-, contact- and hot air shrink units.
 $\varnothing 6 - \varnothing 32$ with h₆-tolerance

Observation: Porte-outils convenables pour machines à frotter par induction, par contact, ou par air chaud.
 $\varnothing 6 - \varnothing 32$ avec h₆-tolerance



Shrink chucks 4,5° for mounting of solid carbide and HSS-tool shanks

Mandrins de frettage 4,5° pour le serrage de queues d'outils carbures de type HM et HSS



Verwendung:
Zur Aufnahme von Werkzeugen mit Zylinderschaft.

Application:
For mounting straight-shank tools.

Application:
Pour le serrage d'outils avec queue cylindrique.

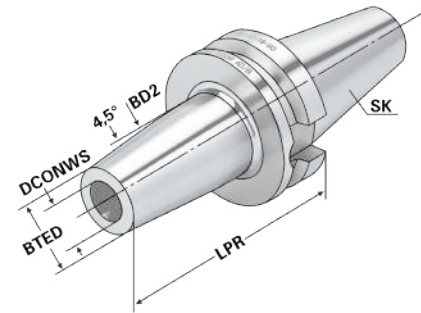

ISO 7388-2 Form JD/JF (AD/B) ≤ 3µm G2.5 25.000 min⁻¹ h6

Bestell-Nr. Order no. Référence	SK	DCONWS	TDCON	LPR	BTED	BD2	LSCN	LSCX	ADJRGA	THID
505.71.06.2	BT 50	6	h6	160	21	27	22	36	10	M5x0,8
505.71.08.2	BT 50	8	h6	160	21	27	26	36	10	M6x1
505.71.10.2	BT 50	10	h6	160	24	32	31	41	10	M8x1
505.71.12.2	BT 50	12	h6	160	24	32	36	46	10	M10x1
505.71.14.2	BT 50	14	h6	160	27	34	36	46	10	M10x1
505.71.16.2	BT 50	16	h6	160	27	34	39	49	10	M12x1
505.71.18.2	BT 50	18	h6	160	33	42	39	49	10	M12x1
505.71.20.2	BT 50	20	h6	160	33	42	41	51	10	M16x1
505.71.25.2	BT 50	25	h6	160	44	53	47	57	10	M16x1
505.71.32.2	BT 50	32	h6	160	44	53	51	61	10	M16x1
505.71.06.3	BT 50	6	h6	200	21	27	22	36	10	M5x0,8
505.71.08.3	BT 50	8	h6	200	21	27	26	36	10	M6x1
505.71.10.3	BT 50	10	h6	200	24	32	31	41	10	M8x1
505.71.12.3	BT 50	12	h6	200	24	32	36	46	10	M10x1
505.71.14.3	BT 50	14	h6	200	27	34	36	46	10	M10x1
505.71.16.3	BT 50	16	h6	200	27	34	39	49	10	M12x1
505.71.18.3	BT 50	18	h6	200	33	42	39	49	10	M12x1
505.71.20.3	BT 50	20	h6	200	33	42	41	51	10	M16x1
505.71.25.3	BT 50	25	h6	200	44	53	47	57	10	M16x1

LSCX = Einspannlänge, max. ADJRGA = Verstellweg, max.
 LSCX = Clamping depth, max. ADJRGA = Length adjustment range, max.
 LSCX = Profondeur d'insertion, max. ADJRGA = Course de réglage, max.

Hinweis: Aufnahme für Induktiv-, Kontakt- und Heißluftschumpfergeräte geeignet. Schafttoleranz bei Ø 6 - Ø 32 mm = h₆

Note: Toolholders suitable for induction-, contact- and hot air shrink units. Ø 6 - Ø 32 with h₆-tolerance

Observation: Porte-outils convenables pour machines à fretter par induction, par contact, ou par air chaud. Ø 6 - Ø 32 avec h₆-tolerance





Shrink chucks 4,5° for mounting of solid carbide and HSS-tool shanks

Mandrins de frettage 4,5° pour le serrage de queues d'outils carbures de type HM et HSS

2



Verwendung:

Zur Aufnahme von Werkzeugen mit Zylinderschaft.

Application:

For mounting straight-shank tools.

Application:

Pour le serrage d'outils avec queue cylindrique.

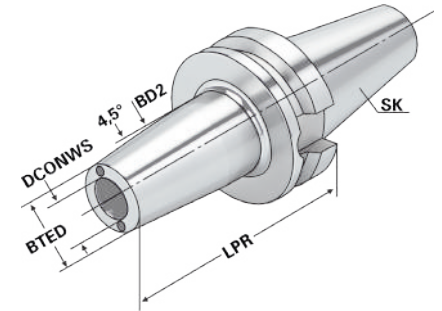

Bestell-Nr. Order no. Référence	SK	DCONWS	TDCON	LPR	BTED	BD2	LSCN	LSCX	ADJRGA	THID
406.70.06.K	BT 40	6	h6	90	21	27	22	36	10	M5x0,8
406.70.08.K	BT 40	8	h6	90	21	27	26	36	10	M6x1
406.70.10.K	BT 40	10	h6	90	24	32	31	41	10	M8x1
406.70.12.K	BT 40	12	h6	90	24	32	36	46	10	M10x1
406.70.14.K	BT 40	14	h6	90	27	34	36	46	10	M10x1
406.70.16.K	BT 40	16	h6	90	27	34	39	49	10	M12x1
406.70.18.K	BT 40	18	h6	90	33	42	39	49	10	M12x1
406.70.20.K	BT 40	20	h6	90	33	42	41	51	10	M16x1
506.71.06.K	BT 50	6	h6	100	21	27	22	36	10	M5x0,8
506.71.08.K	BT 50	8	h6	100	21	27	26	36	10	M6x1
506.71.10.K	BT 50	10	h6	100	24	32	31	41	10	M8x1
506.71.12.K	BT 50	12	h6	100	24	32	36	46	10	M10x1
506.71.14.K	BT 50	14	h6	100	27	34	36	46	10	M10x1
506.71.16.K	BT 50	16	h6	100	27	34	39	49	10	M12x1
506.71.18.K	BT 50	18	h6	110	33	42	39	49	10	M12x1
506.71.20.K	BT 50	20	h6	110	33	42	41	51	10	M16x1

LSCX = Einspannlänge, max.
LSCX = Clamping depth, max.
LSCX = Profondeur d'insertion, max.

ADJRGA = Verstellweg, max.
ADJRGA = Length adjustment range, max.
ADJRGA = Course de réglage, max.

Hinweis: Aufnahme für Induktiv-, Kontakt- und Heißluftschumpfgeräte geeignet. Schafttoleranz bei Ø 6 – Ø 25 mm = h₆

Note: Toolholders suitable for induction-, contact- and hot air shrink units. Ø 6 – Ø 25 with h₆-tolerance

Observation: Porte-outils convenables pour machines à fretter par induction, par contact, ou par air chaud. Ø 6 – Ø 25 avec h₆-tolerance



Shrink fit extensions (with end stop)
Rallonges de frettage (avec butée)



Verwendung:
Zur Aufnahme von Werkzeugen mit Zylinderschaft.
Application:
For mounting straight-shank tools.
Application:
Pour le serrage d'outils avec queue cylindrique.

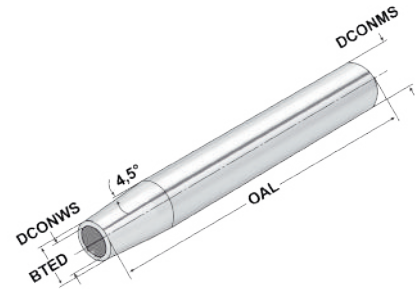

2



Bestell-Nr. Order no. Référence	DCONMS	DCONWS	BTED	OAL	LSCN	LSCX	ADJRGA	THID
120.70.03	20	3	10	150	6	-	-	-
120.70.04	20	4	10	150	8	-	-	-
120.70.05	20	5	10	150	10	-	-	-
120.70.06*	20	6	10	150	22	36	10	M5x0,8
120.70.08*	20	8	12	150	26	36	10	M6x1
120.70.10*	20	10	14	150	31	41	10	M8x1
120.70.12*	20	12	16	150	36	46	10	M10x1

* mit Anschlag | * with end stop | * avec butée

Durchgangsbohrung für Innenkühlung vorhanden.
Through hole for internal cooling provided.
Trou débouchant disponible pour arrosage interne.

LSCX = Einspannlänge, max. ADJRGA = Verstellweg, max.
LSCX = Clamping depth, max. ADJRGA = Length adjustment range, max.
LSCX = Profondeur d'insertion, max. ADJRGA = Course de réglage, max.

Für Ø 3, 4 und 5 mm nur Hartmetallschäfte verwenden!
For Ø 3, 4 and 5 mm only solid carbide tool shanks must be used!
Pour Ø 3, 4 et 5 mm il faut seulement utiliser de queues d'outils carbures de type HM!

Hinweis: Aufnahmen für Induktiv-, Kontakt- und Heißluftschumpfergeräte geeignet.
Schafttoleranz bei Ø 3, 4 und 5 mm = h₄, bei Ø 6 – Ø 32 mm = h₆

Note: Toolholders suitable for induction-, contact- and hot air shrink units.
Ø 3, 4, 5 with h₄-tolerance and Ø 6 – Ø 32 with h₆-tolerance

Observation: Porte-outils convenables pour machines à fretter par induction, par contact, ou par air chaud.
Ø 3, 4, 5 avec h₄-tolerance et Ø 6 – Ø 32 avec h₆-tolerance

**WERKZEUGAUFNAHMEN
MIT PLANANLAGE**

**TOOLHOLDERS
TAPER FACE**

**PORTE-OUTILS
CONTACT DIRECT**

DUAL CONTACT

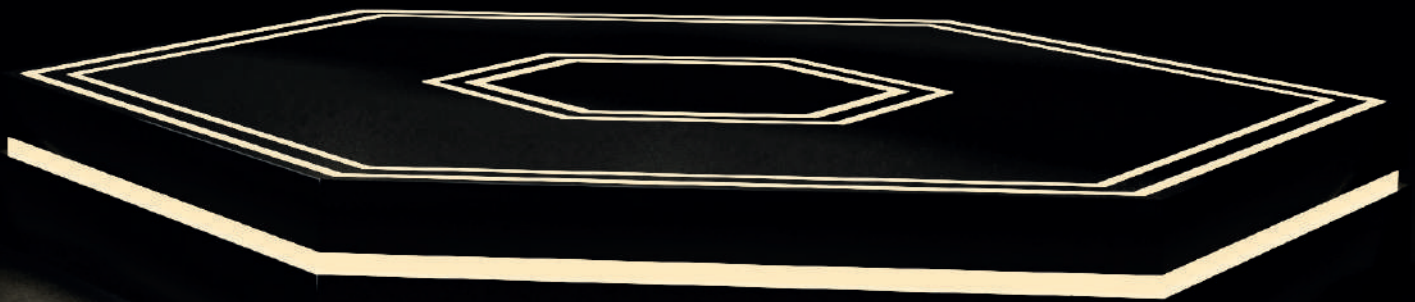

Toolholders similar DIN ISO 7388-1 (formerly DIN 69871) with face contact

Porte-outils similaire à DIN ISO 7388-1 (l'ancien DIN 69871) avec contact face

3

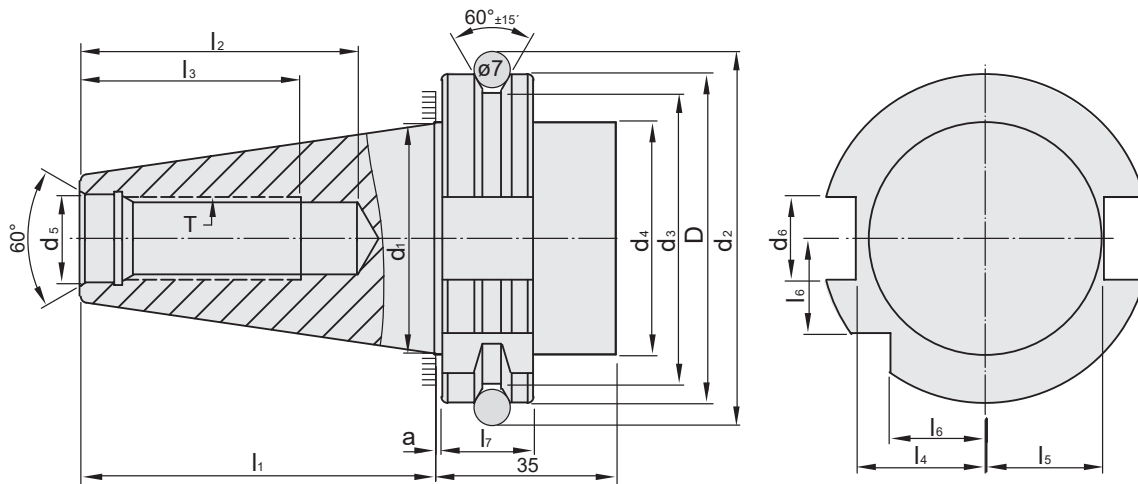

SK	D	d ₁	d ₂	d ₃	d ₄	d ₅	d ₆	d ₉	l ₁	l ₂	l ₃	l ₄	l ₅	l ₆	l ₇	a	e ₁	e ₂	T
	$\begin{matrix} 0 \\ -0,1 \end{matrix}$		$\pm 0,05$	$\begin{matrix} 0 \\ -0,5 \end{matrix}$	max	H7	H12		$\begin{matrix} 0 \\ -0,3 \end{matrix}$	min	min	$\begin{matrix} 0 \\ -0,4 \end{matrix}$	$\begin{matrix} 0 \\ -0,4 \end{matrix}$	$\begin{matrix} 0 \\ -0,3 \end{matrix}$	$\begin{matrix} +0,1 \\ 0 \end{matrix}$	$\begin{matrix} 0 \\ -0,005 \end{matrix}$	$\pm 0,1$	max	
40	63,55	44,45	72,30	56,25	50	17	16,1	4	68,4	42,5	32	25	22,8	18,5	18,1	1	27	5	M16
50	97,50	69,85	107,25	91,25	80	25	25,7	6	101,75	61,5	47	37,7	35,5	30	17,6	1,5	42	7	M24

Vorgewuchtet G 6,3 15.000 min⁻¹
Pre-balanced
Pré-équilibré

G 2,5 Feinwuchten gegen Aufpreis
G 2.5 Fine balancing at extra charge
G 2,5 Equilibrage fin contre un supplément

Mit innerer Kühlmittelzufuhr über den Bund - Form AD/AF (AD/B)

With internal coolant through the collar - form AD/AF (AD/B)

Avec arrosage interne par la collerette - forme AD/AF (AD/B)

Bei Lieferung mit Gewindestiften verschlossen
Delivery with headless screws in closed position
Livraison en état fermé avec de vis sans tête

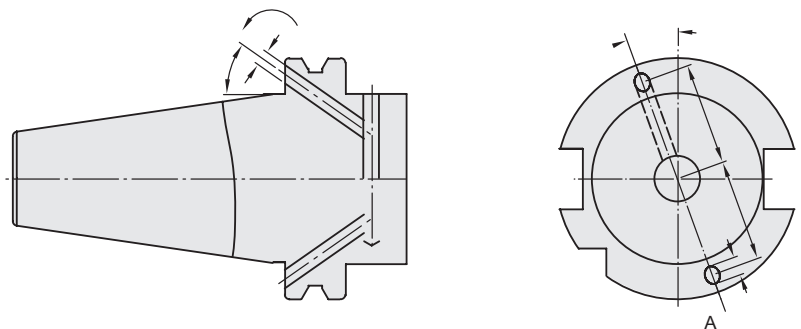

Werkstoff: Legierter Einsatzstahl mit einer Zugfestigkeit im Kern von min. 950 N / mm². Einsatzgehärtet HRC 60 ± 2 (HV 700 ± 50), Härtetiefe 0,8 mm ± 0,2 mm, brüniert und präzisionsgeschliffen.

Form AD/AF: Lieferung in Ausführung AD, Form AF (B) mit lösbaren Gewindestiften verschlossen.

Genauigkeit: Kegelwinkel - Toleranzqualität < AT 3 nach DIN 7187 und DIN 2080.

Material: Alloyed case-hardened steel, tensile core strength of min. 950 N / mm². Case hardened HRC 60 ± 2 (HV 700 ± 50), hardening depth 0.8 mm ± 0.2 mm, black-finished and precisely grinded.

Form AD/AF: Delivery in form AD, type (B) closed with releasable headless screws.

Accuracy: Quality of taper < AT 3 according to DIN 7187 and DIN 2080.

Matière: Acier de cémentation allié. Résistance à la traction dans le noyau d'au moins 950 N / mm². Cémenté et trempé HRC 60 ± 2 (HV 700 ± 50), profondeur de trempé 0,8 mm ± 0,2 mm, brunie et rectifiée avec précision.

Forme AD/AF: Livraison en forme AD, forme AF (B) fermée avec de vis sans tête amovibles.

Précision: Angle de cône - qualité de tolérance < AT 3 selon DIN 7187 et DIN 2080



3.05	3.06	3.07	3.09
3.10	3.11	3.12	3.13
3.14	3.15	3.16	3.17
3.18	3.19	3.20	3.21
3.23			

3

DIN ISO 7388-2

BT

DUAL CONTACT



Werkzeugaufnahmen ähnlich DIN ISO 7388-2 (ehem. JIS B 6339) mit Plananlage ab Seite 3.23

Toolholders similar DIN ISO 7388-2 with face contact (formerly JIS B 6339) from page 3.23

Porte-outils similaire à DIN ISO 7388-2 avec contact face (l'ancien JIS B 6339) à partir de la page 3.23

K Spannfutter für Spannzangen ISO 15488 (DIN 6499) System ER Plananlage ISO 7388-1

Collet chucks for collets ISO 15488 (DIN 6499) ER-system
Mandrins à pinces pour pinces ISO 15488 (DIN 6499) système ER

Dual Contact ISO 7388-1

3



Verwendung:
Zur Aufnahme von Werkzeugen mit Zylinderschaft in Spannzangen.

Application:
For mounting straight-shank tools in collets.

Application:
Destiné à recevoir les outils avec les queues de forme cylindrique dans les pinces de serrage.

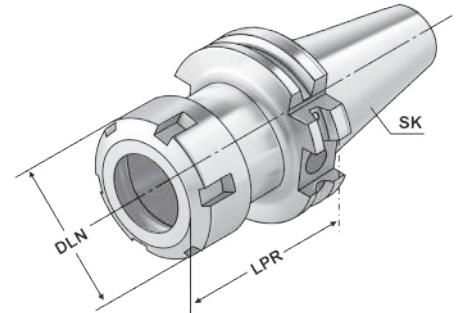

ISO 7388-1 DC

Form AD/AF (AD/B)

≤ 3µm

G2.5 25.000 min⁻¹

RFID Chip

ISO 15488

13.04

Bestell-Nr. Order no. Référence	SK	DCONWS Spannbereich Capacity Capacité	Typ	LPR	DLN	THID
DC.403.02.10	SK-DC 40	1 – 10	426E ER 16	63	32	M10x1,5
DC.403.02.16	SK-DC 40	2 – 16	430E ER 25	60	42	M16x2,0
DC.403.02.20	SK-DC 40	2 – 20	470E ER 32	70	50	M16x2,0
DC.403.02.26	SK-DC 40	3 – 26	472E ER 40	80	63	M16x2,0
DC.403.02.10.1	SK-DC 40	1 – 10	426E ER 16	100	32	M10x1,5
DC.403.02.16.1	SK-DC 40	2 – 16	430E ER 25	100	42	M16x2,0
DC.403.02.20.1	SK-DC 40	2 – 20	470E ER 32	100	50	M16x2,0
DC.403.02.26.1	SK-DC 40	3 – 26	472E ER 40	100	63	M16x2,0
DC.403.02.10.2	SK-DC 40	1 – 10	426E ER 16	160	32	M10x1,5
DC.403.02.16.2	SK-DC 40	2 – 16	430E ER 25	160	42	M16x2,0
DC.403.02.20.2	SK-DC 40	2 – 20	470E ER 32	160	50	M16x2,0
DC.403.02.26.2	SK-DC 40	3 – 26	472E ER 40	160	63	M16x2,0

Lieferumfang: Mit gewuchteter Spannmutter
Delivery: With balanced clamping nut
Livraison: Avec écrou de serrage équilibré

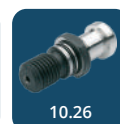
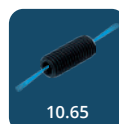
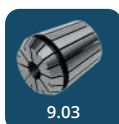



Precision collet chuck ER for collets DIN 6499 (ISO 15488) ER-system

Mandrin à pinces ER de précision pour pinces DIN 6499 (ISO 15488) système ER



Verwendung:
Zur Aufnahme von Werkzeugen mit Zylinderschaft in 3 µm-Spannzangen.

Application:
For mounting straight-shank tools in 3 µm-collets.

Application:
Pour le serrage d'outils avec queue cylindrique dans des pinces de serrage 3 µm.

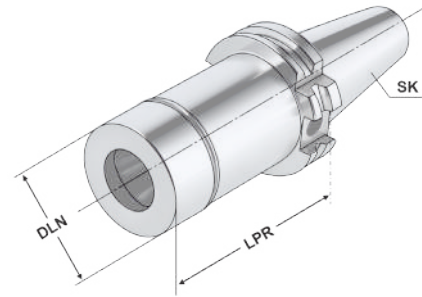

ISO 7388-1 DC Form AD $\leq 3\mu\text{m}$ G2.5 25.000 min⁻¹ RFID Chip ISO 15488

Bestell-Nr. Order no. Référence	SK	DCONWS Spannbereich Capacity Capacité	Typ	LPR	LB	DLN	THID
DC.402.P2.20.070	SK-DC 40	2 - 20	470E ER 32	70	50,9	50	M16 x 2,0
DC.402.P2.20.100	SK-DC 40	2 - 20	470E ER 32	100	80,9	50	M16 x 2,0

Vorteile:

Exzellente Rundlaufgenauigkeit im System (Futter + Spannzange + Spannmutter)
 Extreme Haltekräfte (erhöht die Haltekraft um mindestens 60 % im Vergleich zu Standard ER-Futter)
 Glatte Spannmutter ohne Nuten für Hochgeschwindigkeitsbearbeitung

Advantages:

Excellent concentricity in the system (chuck + collet + clamping nut)
 Extremely strong holding force (increases the holding power by at least 60% compared to standard ER chuck)
 Plain clamping nut without grooves for high speed machining

Avantages:

Excellente précision de concentricité dans le système (mandrin + pince de serrage + écrou de serrage)
 La force de maintien extrême (augmente la force de maintien d'au moins à 60% par rapport aux mandrins standards ER)
 Ecrou de serrage lisse sans rainures pour l'usinage à haute vitesse

Hinweis:

Nur das Nennmaß DCONWS kann gespannt werden.

Note:

Only nominal size DCONWS can be clamped.

Observation:

Seulement la dimension nominale DCONWS peut être serrée.

Lieferumfang:

Inklusive Präzisions-Spannmutter

Delivery:

With precision clamping nut

Livraison:

Avec écrou de serrage de précision





Verwendung:
Zur Aufnahme von Werkzeugen mit Zylinderschaft nach DIN 1835 Form A+B+E und DIN 6535 Form HB+HE

Application:
For mounting straight-shank tools acc. DIN 1835 form A+B+E and DIN 6535 form HB+HE

Application:
Destiné à recevoir les outils avec les queues de forme cylindrique suivant DIN 1835 en forme A+B+E et DIN 6535 en forme HB+HE

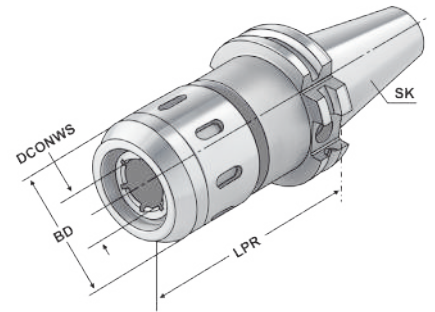

3

ISO 7388-1 DC	Form AD/AF (AD/B)	≤ 3µm	G6.3 15.000 min ⁻¹	RFID Chip	HKS	13.04
---------------	-------------------	-------	-------------------------------	-----------	-----	-------

Bestell-Nr. Order no. Référence	SK	DCONWS Spannbereich Capacity Capacité	Typ	DCONWS	LPR	BD
DC.403.64.20	SK-DC 40	3 - 20	HKS 20	20	90	53
DC.403.64.25	SK-DC 40	3 - 25	HKS 25	25	105	63
DC.403.64.32	SK-DC 40	3 - 32	HKS 32	32	105	68

Größe Size Taille	20mm	25mm	32mm
Anzugsmoment Clamping torque Couple	50-70 Nm	80-100 Nm	80-100 Nm
Spannkraft Clamping force Tension	780 Nm	2000 Nm	2000 Nm

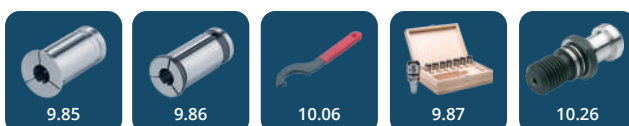

RELEASE THE BEAST



3



Verwendung:
 Zum Spannen von zylindrischen Werkzeugschäften mit seitlicher Spannfläche nach DIN 1835 Form B (Weldon).

Application:
 For mounting straight-shank tools with lateral flat according to DIN 1835 form B (Weldon).

Application:
 Pour le serrage d'outils avec queue cylindrique et avec méplat de serrage latérale suivant DIN 1835 forme B (Weldon).

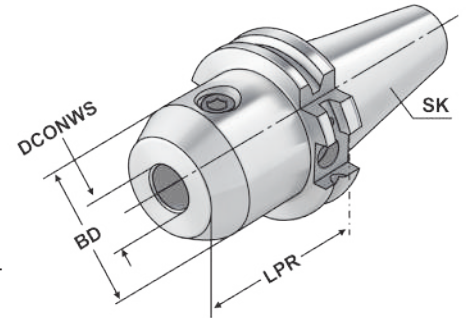

ISO 7388-1 DC	Form AD/AF (AD/B)	≤ 3µm	G7.5 25.000 min ⁻¹	RFID Chip	DIN 1835-B	H4	13.04
---------------	-------------------	-------	-------------------------------	-----------	------------	----	-------

Bestell-Nr. Order no. Référence	SK	DCONWS	TDCON	LPR	BD
DC.403.04.06	SK-DC 40	6	H4	50	25
DC.403.04.08	SK-DC 40	8	H4	50	28
DC.403.04.10	SK-DC 40	10	H4	50	35
DC.403.04.12	SK-DC 40	12	H4	50	42
DC.403.04.14	SK-DC 40	14	H4	50	44
DC.403.04.16	SK-DC 40	16	H4	63	48
DC.403.04.18	SK-DC 40	18	H4	63	50
DC.403.04.20	SK-DC 40	20	H4	63	52
DC.403.04.25	SK-DC 40	25	H4	100	65
DC.403.04.32	SK-DC 40	32	H4	100	72
DC.403.04.40	SK-DC 40	40	H4	120	80
DC.403.04.06.1	SK-DC 40	6	H4	100	25
DC.403.04.08.1	SK-DC 40	8	H4	100	28
DC.403.04.10.1	SK-DC 40	10	H4	100	35
DC.403.04.12.1	SK-DC 40	12	H4	100	42
DC.403.04.14.1	SK-DC 40	14	H4	100	44
DC.403.04.16.1	SK-DC 40	16	H4	100	48
DC.403.04.18.1	SK-DC 40	18	H4	100	50
DC.403.04.20.1	SK-DC 40	20	H4	100	52

Hinweis: Ab DCONWS = 25 mit zwei Spannschrauben
Note: From DCONWS = 25 on two clamping screws
Observation: A partir de DCONWS = 25 avec deux vis de serrage

Lieferumfang: Mit Spannschraube
Delivery: With clamping screw
Livraison: Avec vis de serrage



Nachträgliches Erodieren von 2 Kühlkanalbohrungen
 Supplementary eroding of 2 cooling channels
 Erodage complémentaire de 2 trous de canaux de refroidissement

Bestell-Nr.
Order no.
Référence

U.KKB



End mill holders DIN 6359 with coolant channels for end mills DIN 1835-B
Porte-fraises DIN 6359 avec canaux d'arrosage pour queues cylindriques DIN 1835-B



Verwendung:
Zum Spannen von zylindrischen Werkzeugschäften mit seitlicher Spannfläche nach DIN 1835 Form B (Weldon). Mit Kühlkanälen für optimale Kühlung der Werkzeugschneide.

Application:
For mounting straight-shank tools with lateral flat according to DIN 1835 form B (Weldon). With coolant channels for optimal coolant at the cutting edge.

Application:
Pour le serrage d'outils avec queue cylindrique et avec méplat de serrage latéral suivant DIN 1835 forme B (Weldon). Avec canaux d'arrosage pour refroidissement optimal des coupes.

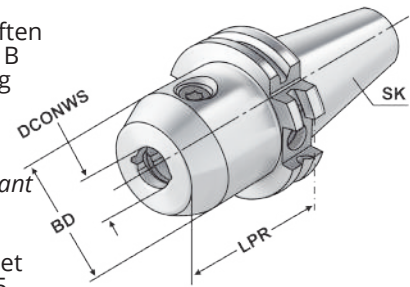

3

ISO 7388-1 DC	Form AD/AF (AD/B)	≤ 3µm	G2.5 25.000 min ⁻¹	RFID Chip	DIN 1835-B	H4			13.04
---------------	-------------------	-------	-------------------------------	-----------	------------	----	--	--	-------

Bestell-Nr. Order no. Référence	SK	DCONWS	TDCON	LPR	BD
DC.403.04.06.K	SK-DC 40	6	H4	50	25
DC.403.04.08.K	SK-DC 40	8	H4	50	28
DC.403.04.10.K	SK-DC 40	10	H4	50	35
DC.403.04.12.K	SK-DC 40	12	H4	50	42
DC.403.04.14.K	SK-DC 40	14	H4	50	44
DC.403.04.16.K	SK-DC 40	16	H4	63	48
DC.403.04.18.K	SK-DC 40	18	H4	63	50
DC.403.04.20.K	SK-DC 40	20	H4	63	52

Hinweis: Ab DCONWS = 25 mit zwei Spansschrauben
DCONWS = 6 bis 18 mit zwei Kühlkanälen
DCONWS = 20 bis 40 mit vier Kühlkanälen
Für Werkzeuge mit innerer Kühlmittelzufuhr muss ein O-Ring eingesetzt werden.

Note: From DCONWS = 25 on two clamping screws
DCONWS = 6 to 18 with two coolant channels
DCONWS = 20 to 40 with four coolant channels
For tools with through coolant an O-ring must be used.

Observation: A partir de DCONWS = 25 avec deux vis de serrage
DCONWS = 6 bis 18 avec deux canaux d'arrosage
DCONWS = 20 bis 40 avec quatre canaux d'arrosage
Pour outils avec arrosage interne il faut utiliser un joint torique.

Lieferumfang: Mit Spansschraube und O-Ring
Delivery: With clamping screw and O-ring
Livraison: Avec vis de serrage et joint torique





3



Verwendung:
Zur Aufnahme von Einschraubfräser mit Gewinde.

Application:
For mounting screw-in cutters with thread.

Application:
Pour le serrage de fraises à queue fileté.

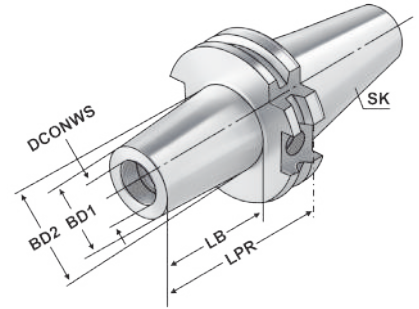

ISO 7388-1 DC	Form AD/AF (AD/B)	$\leq 3\mu\text{m}$	G2.5 25.000 min ⁻¹	RFID Chip	H7
---------------	-------------------	---------------------	-------------------------------	-----------	----

Bestell-Nr. Order no. Référence	SK	THSZWS	DCONWS	BD1	BD2	LPR	LB
DC.403.06.12	SK-DC 40	M12	12,5	21	24	44	25
DC.403.06.12.1	SK-DC 40	M12	12,5	21	24	69	50
DC.403.06.12.2	SK-DC 40	M12	12,5	21	31	94	75
DC.403.06.16.0	SK-DC 40	M16	17	29	29	24	5
DC.403.06.16	SK-DC 40	M16	17	29	29	44	25
DC.403.06.16.1	SK-DC 40	M16	17	29	34	69	50
DC.403.06.16.2	SK-DC 40	M16	17	29	34	94	75

Empfohlenes Anzugsmoment Recommended tightening torques Torques de serrage recommandés	
M6	10 Nm
M8	25 Nm
M10	40 Nm
M12	60 Nm
M16	50 Nm





Adaptor sleeves for MT with tang DIN 6383
 Douilles de réduction pour CM à tenon DIN 6383

Dual Contact ISO 7388-1



Verwendung:
 Zur Aufnahme von Werkzeugen mit Morsekegelschaft und Austreibblappen nach DIN 228-1 Form B.

Application:
 For mounting tools with Morse taper shank and tang according to DIN 228-1 form B.

Application:
 Pour le serrage d'outils avec queue cône Morse et tenon suivant DIN 228-1 forme B.

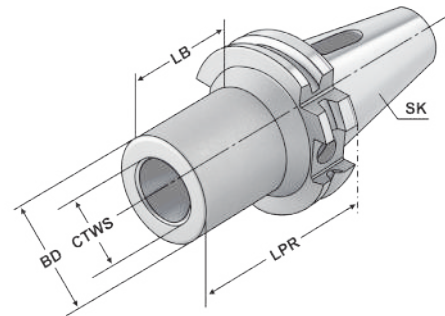

ISO 7388-1 DC	Form AD/AF (AD/B)	≤ 5µm	G6.3 15.000 min ⁻¹	RFID Chip	DIN 6383	AT5
---------------	-------------------	-------	-------------------------------	-----------	----------	-----

Bestell-Nr. Order no. Référence	SK	CTWS	TDCON	LPR	LB	BD
DC.403.07.01	SK-DC 40	1	AT5	50	31	25
DC.403.07.02	SK-DC 40	2	AT5	50	19	32
DC.403.07.03	SK-DC 40	3	AT5	70	44	40
DC.403.07.04	SK-DC 40	4	AT5	95	76	48





3



Verwendung:
Zur Aufnahme von Walzen-, Walzenstirnfräsern oder Messerköpfen mit Längs- oder Quernut.

Application:
For mounting milling cutters with transverse or longitudinal groove.

Application:
Destiné à recevoir les porte-fraises, les fraises cylindriques ou les têtes de fraisage avec rainure longitudinale et transversale.

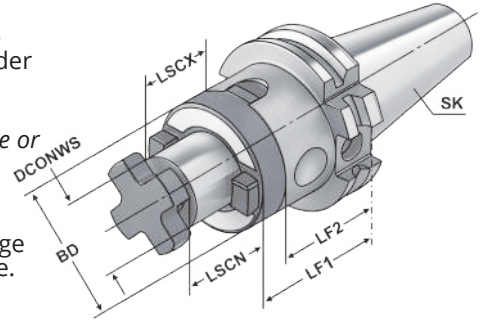

ISO 7388-1 DC	Form AD/AF (AD/B)	$\leq 5\mu\text{m}$	G6.3 15.000 min ⁻¹	RFID Chip	DIN 6358	h6
---------------	-------------------	---------------------	-------------------------------	-----------	----------	----

Bestell-Nr. Order no. Référence	SK	DCONWS	TDCON	LF1	LF2	LSCN	LSCX	BD
DC.403.10.16	SK-DC 40	16	h6	55	45	17	27	32
DC.403.10.22	SK-DC 40	22	h6	55	43	19	31	40
DC.403.10.27	SK-DC 40	27	h6	55	43	21	33	48
DC.403.10.32	SK-DC 40	32	h6	60	46	24	38	58
DC.403.10.40	SK-DC 40	40	h6	60	46	27	41	70

Lieferumfang: Mit Fräseranzugsschraube, Mitnehmerring und Passfeder
Delivery: With retaining screw, driving ring and feather key
Livraison: Avec vis de serrage, bague d'entraînement et clavette



Shell mill holders DIN 6357 with enlarged contact face and coolant exit bores on the end face
Porte-fraises à trou lisse DIN 6357 avec face de contact élargie et conduits pour l'arrosage frontal



Verwendung:
Zur Aufnahme von Messerköpfen und Fräsern mit Quernut.

Application:
For mounting milling cutters with transversal groove.

Application:
Destiné à recevoir les fraises et les fraises avec des rainures transversales.

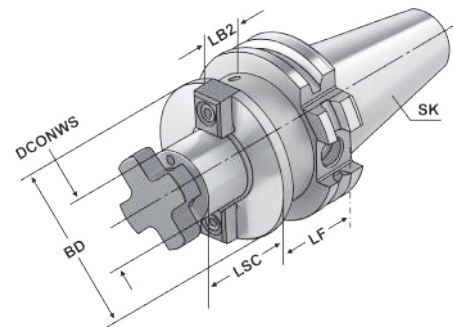

3

ISO 7388-1 DC

Form AD/AF (AD/B)

≤ 5µm

G2.5 25.000 min⁻¹

RFID Chip

DIN 6357

h6

Bestell-Nr. Order no. Référence	SK	DCONWS	TDCON	LF	LSC	LB2	BD
DC.403.11.16	SK-DC 40	16	h6	35	17	15,9	38
DC.403.11.22	SK-DC 40	22	h6	35	19	15,9	48
DC.403.11.27	SK-DC 40	27	h6	40	21	20,9	58
DC.403.11.32	SK-DC 40	32	h6	50	24	30,9	78
DC.403.11.40	SK-DC 40	40	h6	50	27	30,9	88
DC.403.11.16.1	SK-DC 40	16	h6	100	17	80,9	38
DC.403.11.22.1	SK-DC 40	22	h6	100	19	80,9	48
DC.403.11.27.1	SK-DC 40	27	h6	100	21	80,9	58

DCONWS = 40 Für große Planfräser mit vier zusätzlichen Gewindebohrungen nach DIN 2079.
For large diameter face mill cutters with four additional threaded holes according to DIN 2079.
Pour fraises à surfacer à grands diamètres avec 4 taraudages supplémentaires suivant DIN 2079.

Lieferumfang: Mit Mitnehmersteinen, Kreuzschraube und Zylinderkopfschraube nach DIN 912 für Fräser mit innerer Kühlmittelzufuhr.

Delivery: With drivers, cross head retaining screw and cylinder head retaining screw for cutters with central coolant.

Livraison: Avec tenons, une vis cruciforme et une vis à tête cylindrique suivant DIN 912 pour fraises avec arrosage central.





3



Verwendung:
Zur Aufnahme von Werkzeugen mit Zylinderschaft.

Application:
For mounting tools with straight shanks.

Application:
Pour le serrage d'outils avec queue cylindrique.

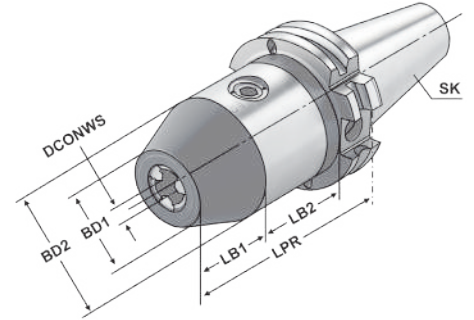

ISO 7388-1 DC Form AD/AF (AD/B) $\leq 30\mu\text{m}$ G6.3 15.000 min⁻¹ RFID Chip



Bestell-Nr. Order no. Référence	SK	DCONWS Spannbereich Capacity Capacité	LPR	LB1	LB2	LF	BD1	BD2	DRVS
DC.403.15.13	SK-DC 40	1,0 – 13	90	26,2	44,8	71	31,0	50	6
DC.403.15.16	SK-DC 40	2,5 – 16	95	31,0	45,0	76	27,5	50	6

Hinweis: Hohe Präzision und Rundlaufgenauigkeit von $\leq 0,03$ mm. Sichere Spannung des Werkzeuges durch mechanische Spannkraftverstärkung. Kein selbständiges Lösen der Spannung während der Bearbeitung bei Links- oder Rechtslauf, sowie bei Spindelstop. Spannen und Lösen mit Sechskantschlüssel.

Note: High precision and accurate concentricity of ≤ 0.03 mm. Secure gripping of the tool through mechanical amplification of the clamping force. No automatic slackening of the clamping force while machining with either clockwise or counter clockwise rotation or on spindle stop. Clamping and releasing effected by means of an Allen wrench.

Observation: Précision élevée et exactitude de circularité de $\leq 0,03$ mm. Serrage sûr de l'outil grâce à l'amplification de la force de serrage. Pas de desserrage intempestif en cours d'usinage lors de la rotation la gauche ou la droite, de même qu'en cas d'arrêt de la broche. Serrage et desserrage en utilisant un clé sur à fourche.

Lieferumfang: Ohne Spannschlüssel
Delivery: Without wrench
Livraison: Sans clé de serrage



Boring bar blanks
Barres d'alésage

Dual Contact ISO 7388-1



Verwendung:
Zur Herstellung von Sonderwerkzeugen.
Application:
For the manufacturing of special tools.
Application:
Pour la fabrication d'outils spéciaux.



3

ISO
7388-1
DC

Form
A

RFID
Chip

Bestell-Nr.
Order no.
Référence

SK

BD

LB

LPR

DC.402.17.63

SK-DC 40

63

215

250

Ausführung: Steilkegel und Bund gehärtet und geschliffen. Schaft weich zur weiteren Bearbeitung.
Version: *Cone and flange hardened and grinded. Soft body for later processing.*
Version: Cône et collerette durcis et rectifiés. Corps doux pour un usinage ultérieur.



10.26



Quick change tapping chucks *with length compensation on compression and expansion*
Mandrins de taraudage à changement rapide *avec compensation longitudinale à la compression et traction*



Verwendung:
Zur Aufnahme von Schnellwechsel-Ein-sätzen für Gewindebohrer.

Application:
For the chucking of quick change adaptors for taps.

Application:
Pour le serrage d'adapteurs porte-tarauts à changement rapide.

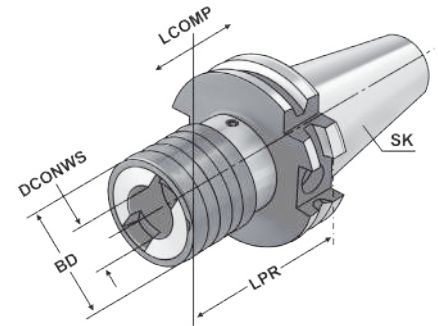

3

ISO 7388-1 DC

Form A



RFID Chip



13.04

Bestell-Nr. Order no. Référence	SK	Spannbereich Capacity Capacité	SZID	DCONWS	LPR	BD	LCOMP
DC.402.16.12	SK-DC 40	M3 - M14	1	19	63	36	7
DC.402.16.20	SK-DC 40	M5 - M22	2	31	97	53	12

Hinweis: Für Bearbeitungszentren ohne Synchronspindel.
Note: *For machining centres without synchronous spindle.*
Observation: Pour centres d'usinage sans broche synchrone.





Tapping chucks for synchronisation for collets DIN 6499 (ISO 15488) ER-system

Mandrins de taraudage pour synchronisation pour pinces DIN 6499 (ISO 15488) système ER



Verwendung:
Für Bearbeitungszentren mit Synchronspindel.
Application:
For machining centres with synchronous spindle.
Application:
Pour centres d'usinage avec broche syn-
chrone.

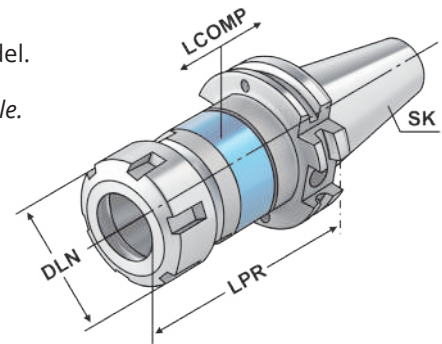

ISO 7388-1 DC	Form AD/AF (AD/B)	≤ 60µm	G6.3 15.000 min ⁻¹	RFID Chip	ISO 15488	+	13.04
---------------	-------------------	--------	-------------------------------	-----------	-----------	---	-------

Bestell-Nr. Order no. Référence	SK	DCONWS Spannbereich Capacity Capacité	Typ	LPR	DLN	LCOMP
DC.403.16.02.10 ¹	SK-DC 40	M3 – M12	426E ER 16 SW25	79	28	0,5
DC.403.16.02.16	SK-DC 40	M3 – M20	430E ER 25	84	42	0,5
DC.403.16.02.20	SK-DC 40	M3 – M27	470E ER 32	95	50	0,5

¹ **Sechskantmutter**
¹ Hexagonal clamping nut
¹ Écrous hexagonal

- Hinweis:**
- Synchro-Gewindeschneidfutter kompensieren Synchronisationsfehler.
 - Minimallängenausgleich in Druck- und Zugrichtung zwischen Synchronspindel und Gewindebohrer reduziert zu hohe Gewindeflankenreibungskräfte.
 - Reduziert eventuelle Axialkraftherhöhung während des Schneidzyklus auf ein Minimum.
 - Geeignet für Innenkühlung.
 - Kühlmitteldruck max. 100 bar.

- Note:**
- *Synchro tapping chucks compensate synchronisation errors.*
 - *Minimal length compensation on compression and expansion balances very small pitch differences between synchro spindle and tap, which can cause high frictional forces on the thread flanks.*
 - *A possible increase of axial force during the tapping process is reduced to a minimum.*
 - *Suitable for internal coolant.*
 - *Coolant pressure up to max. 100 bar.*

- Observation:**
- Mandrins de taraudage version „synchro“ compensent les erreurs éventuelles de synchronisation.
 - Compensation longitudinale minimale à la compression et traction entre la broche synchronisée et le taraud réduit la friction au niveau des flancs de filets.
 - Réduit au minimum les efforts éventuelles axiaux lors du cycle de taraudage.
 - Approprié pour la lubrification centrale.
 - Pression de lubrification max. 100 bar.

Lieferumfang: Mit gewuchteter Spannmutter
Delivery: With balanced clamping nut
Livraison: Avec écrou de serrage équilibré





3



Verwendung:
Zur Aufnahme von Werkzeugen mit Zylinderschaft nach DIN 1835 Form A+B+E und DIN 6535 Form HB+HE (größer Ø 20 mm nur mit Reduzierung).

Application:
For mounting straight-shank tools acc. DIN 1835 form A+B+E and DIN 6535 form HB+HE (larger than Ø 20 mm only with reduction sleeve).

Application:
Pour le serrage d'outils avec queue cylindrique suivant DIN 1835 forme A+B+E et DIN 6535 forme HB+HE (à partir de Ø 20 mm seulement avec réduction).

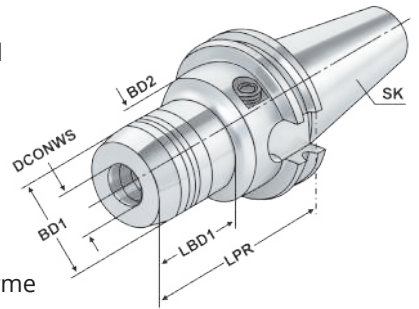

Bestell-Nr. Order no. Référence	SK	DCONWS	LPR	BD1	BD2	LSCX	ADJRGA	LBD1	DRVS	THID
DC.403.H06	SK-DC 40	6	68	26	50	37	10	33	5	M6x1
DC.403.H08	SK-DC 40	8	68	28	50	37	10	33	5	M6x1
DC.403.H10	SK-DC 40	10	72	30	50	42	10	37	5	M8x1
DC.403.H12	SK-DC 40	12	77	32	50	47	10	42	5	M8x1
DC.403.H14	SK-DC 40	14	77	34	50	47	10	42	5	M10x1
DC.403.H16	SK-DC 40	16	80	38	50	52	10	43	5	M10x1
DC.403.H18	SK-DC 40	18	80	40	50	52	10	43	5	M10x1
DC.403.H20	SK-DC 40	20	82	42	50	52	10	47	5	M10x1
DC.403.H25	SK-DC 40	25	117	50	63	58	10	51	6	M12x1
DC.403.H32	SK-DC 40	32	117	60	63	64	10	51	6	M12x1

Lieferumfang: Ohne Spannschlüssel
Delivery: Without wrench
Livraison: Sans clé de serrage

LSCX = Einspannlänge, max. ADJRGA = Verstellweg, max.
 LSCX = Clamping depth, max. ADJRGA = Length adjustment range, max.
 LSCX = Profondeur d'insertion, max. ADJRGA = Course de réglage, max.



Spannkraft-Prüfgerät für Hydrodehnspannfutter - Seite 12.59
Clamping force proofing instrument for hydraulic chucks - page 12.59
 Appareil de contrôle des forces de serrage pour mandrin expansibles hydrauliques - page 12.59





Shrink chucks 4,5° for mounting of solid carbide and HSS-tool shanks

Mandrins de frettage 4,5° pour le serrage de queues d'outils carbures de type HM et HSS



Verwendung:
Zur Aufnahme von Werkzeugen mit Zylinderschaft.

Application:
For mounting straight-shank tools.

Application:
Pour le serrage d'outils avec queue cylindrique.

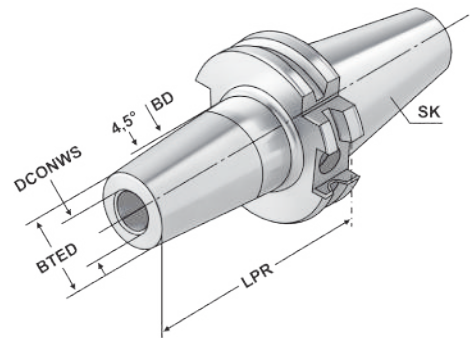

ISO 7388-1 DC Form AD/AF (AD/B) $\leq 3\mu\text{m}$ G2.5 25.000 min⁻¹ RFID Chip h6

Bestell-Nr. Order no. Référence	SK	DCONWS	TDCON	LPR	BTED	BD	LSCN	LSCX	ADJRGA	THID
DC.403.70.03	SK-DC 40	3	h4	80	11	15	6	-	-	-
DC.403.70.04	SK-DC 40	4	h4	80	14	22	8	-	-	-
DC.403.70.05	SK-DC 40	5	h4	80	16	22	10	-	-	-
DC.403.70.06	SK-DC 40	6	h6	80	21	27	22	36	10	M5x0,8
DC.403.70.08	SK-DC 40	8	h6	80	21	27	26	36	10	M6x1
DC.403.70.10	SK-DC 40	10	h6	80	24	32	31	41	10	M8x1
DC.403.70.12	SK-DC 40	12	h6	80	24	32	36	46	10	M10x1
DC.403.70.14	SK-DC 40	14	h6	80	27	34	36	46	10	M10x1
DC.403.70.16	SK-DC 40	16	h6	80	27	34	39	49	10	M12x1
DC.403.70.18	SK-DC 40	18	h6	80	33	42	39	49	10	M12x1
DC.403.70.20	SK-DC 40	20	h6	80	33	42	41	51	10	M16x1
DC.403.70.25	SK-DC 40	25	h6	100	44	53	47	57	10	M16x1
DC.403.70.32	SK-DC 40	32	h6	100	44	53	51	61	10	M16x1

LSCX = Einspannlänge, max. ADJRGA = Verstellweg, max.
 LSCX = Clamping depth, max. ADJRGA = Length adjustment range, max.
 LSCX = Profondeur d'insertion, max. ADJRGA = Course de réglage, max.

Für Ø 3, 4 und 5 mm nur Hartmetallschäfte verwenden
For Ø 3, 4 and 5 mm only solid carbide tool shanks must be used
 Pour Ø 3, 4 et 5 mm il faut seulement utiliser de queues d'outils carbures de type HM

- Hinweis:** Aufnahmen für Induktiv-, Kontakt- und Heißluftschrimpgeräte geeignet. Schafttoleranz bei Ø 3, 4 und 5 mm = h4, bei Ø 6 - Ø 32 mm = h6
- Note:** Toolholders suitable for induction-, contact- and hot air shrink units. Ø 3, 4, 5 with h4-tolerance and Ø 6 - Ø 32 with h6-tolerance
- Observation:** Porte-outils convenables pour machines à fretter par induction, par contact, ou par air chaud. Ø 3, 4, 5 avec h4-tolerance et Ø 6 - Ø 32 avec h6-tolerance



Nachträgliches Erodieren von 2 Kühlkanalbohrungen

Supplementary eroding of 2 cooling channels

Erodage complémentaire de 2 trous de canaux de refroidissement

Bestell-Nr.
Order no.
Référence

U.KKB



3



Verwendung:
Zur Abnahme von Werkzeugmaschinen gemäß ISO-Empfehlung R230 oder zur Überprüfung der Werkzeugspindel.

Application:
For the inspection of machine tools according to ISO recommendation R230 or for testing the tool spindle.

Application:
Pour l'inspection de machine-outils suite à la recommandation ISO R230 ou pour la vérification de la broche.

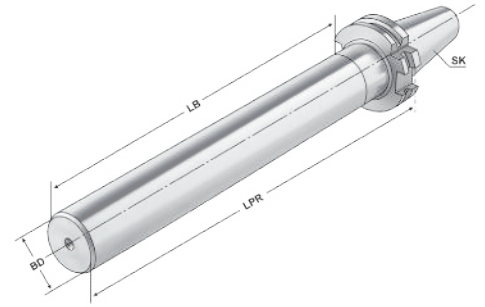

Bestell-Nr. Order no. Référence	SK	LPR	LB	BD	Toleranz Tolerance Tolérance	max. Rundlaufabweichung max. concentricity deviation Faux-rond max.
DC.402.18.40	SK-DC 40	300	256	40	0,003	0,003

Lieferumfang: Auslieferung mit Prüfprotokoll
Delivery: Delivery with test certificate
Livraison: Livraison avec rapport d'essais

Holzkasten für Kontrolldorne

Wooden box for test arbors
Coffret en bois pour mandrins de contrôle



Verwendung:
Zur Aufbewahrung von Kontrolldornen.

Application:
For the storage of test arbors.

Application:
Pour la conservation de mandrins de contrôle.



Bestell-Nr. Order no. Référence	Abmessung Size Dimension	für Kegelgrößen for cones pour cônes
701.18	460 × 130 × 115	SK 30 / 40 / 50



Steep taper toolholders with full face contact Porte-outils conique avec cône face

Die Vorteile sind:

- Maschinenleistung kann voll genutzt werden
- Stabile und vergrößerte, vollständige Plananlage
- Weniger Vibrationen aufgrund der großen Plananlage
- Verbesserte Oberflächengüte und prozesssichere Maßhaltigkeit am Werkstück
- Höhere Standzeit der Schneidwerkzeuge
- Bessere Werkzeugwechsel-Wiederholgenauigkeit
- Kein Stabilitätsverlust bei hohen Spindeldrehzahlen

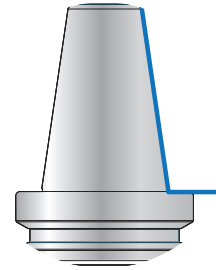

3

The advantages are:

- Machine performance can be used to the full extent
- Stable and bigger, complete full face contact
- Less vibrations due to large full face contact
- Better surface finish and higher reliability of processing
- Longer service life of the cutting tools
- Better tool change repeat accuracy
- No loss of stability at high spindle speeds



Les avantages sont:

- La rendement de machine peut être utilisée entièrement
- Cône face entière, stable et élargi
- Moins vibrations à cause de cône face élargi
- Finition de surface améliorée et tenue des cotes fiable de la pièce usinée
- Tenue de coupe prolongée
- Exactitude de changement d'outil améliorée
- Pas de perte de stabilité à grande vitesse de la broche



K Werkzeugaufnahmen DIN ISO 7388-2 (ehemals JIS B 6339 MAS-BT) mit Plananlage

Toolholders DIN ISO 7388-2 (formerly JIS B 6339 MAS-BT) with face contact

Porte-outils DIN ISO 7388-2 (l'ancien JIS B 6339 MAS-BT) avec contact face

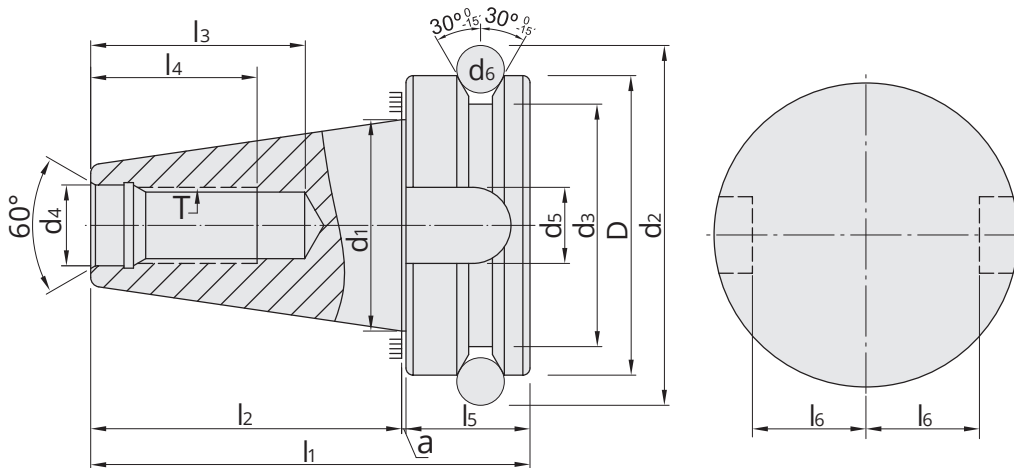

SK	D	d ₁	d ₂	d ₃	d ₄	d ₅	d ₆	d ₉	a	l ₁	l ₂	l ₃	l ₄	l ₅	l ₆	e ₁	e ₂	T
	H8				H8	H12		H12	±0,005		±0,2	min	min		⁰ _{-0,2}	±0,1	max	
30	46	31,75	56,14	38	12,5	16,1	8	-	1	70,4	48,4	34	24	21	16	-	-	M12
40	63	44,45	75,679	53	17	16,1	10	4	1	92,4	65,4	43	30	26	22,6	27	5	M16
50	100	69,85	119,02	85	25	25,7	15	6	1,5	139,8	101,8	62	45	36,5	35,4	42	7	M24

Vorgewuchtet G 6,3 15.000 min⁻¹
Pre-balanced
Pré-équilibré

G 2,5 Feinwuchten gegen Aufpreis
G 2.5 Fine balancing at extra charge
G 2,5 Equilibrage fin contre un supplément

Mit innerer Kühlmittelzufuhr über den Bund - Form JD/JF (AD/B)

With internal coolant through the collar - form JD/JF (AD/B)

Avec arrosage interne par la collerette - forme JD/JF (AD/B)

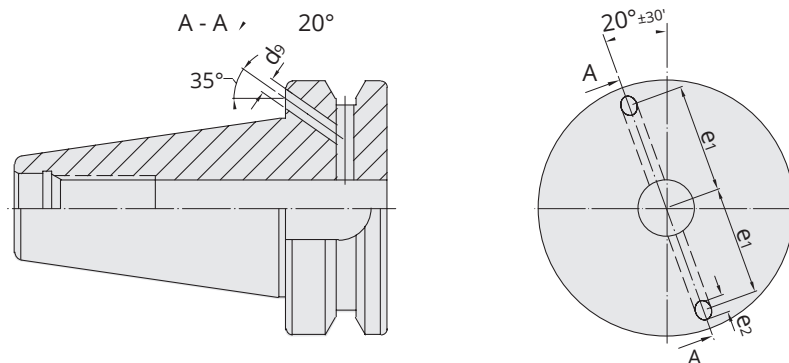

Bei Lieferung mit Gewindestiften verschlossen
Delivery with headless screws in closed position
Livraison en état fermé avec de vis sans tête

Werkstoff: Legierter Einsatzstahl mit einer Zugfestigkeit im Kern von min. 950 N / mm². Einsatzgehärtet HRC 60 ± 2 (HV 700 ± 50), Härtetiefe 0,8 mm ± 0,2 mm, brüniert und präzisionsgeschliffen.

Form JD/JF: Lieferung in Ausführung JD (AD), Form JF (B) mit lösbaren Gewindestiften verschlossen.

Genauigkeit: Kegelminkel - Toleranzqualität < AT 3 nach DIN 7187 und DIN 2080.

Material: Alloyed case-hardened steel, tensile core strength of min. 950 N / mm². Case hardened HRC 60 ± 2 (HV 700 ± 50), hardening depth 0.8 mm ± 0.2 mm, black-finished and precisely grinded.

Form JD/JF: Delivery in form JD (AD), form JF (B) closed with releasable headless screws.

Accuracy: Quality of taper < AT 3 according to DIN 7187 and DIN 2080.

Matière: Acier de cémentation allié. Résistance à la traction dans le noyau de min 950 N / mm². Cémentation à HRC 60 ± 2 (HV 700 ± 50), profondeur de cémentation 0,8 mm ± 0,2 mm, bruni et rectifié précisément.

Forme JD/JF: Livraison en forme JD (AD), forme JF (B) fermée avec des vis amovibles sans tête.

Précision: Qualité du cône < AT 3 selon DIN 7187 et DIN 2080.



3.25	3.26	3.27	3.29
			
3.30	3.31	3.32	3.33
			
3.34	3.35	3.36	3.37
			
3.38	3.39	3.40	3.41
			



Collet chucks for collets ISO 15488 (DIN 6499) ER-system
Mandrins à pinces pour pinces ISO 15488 (DIN 6499) système ER

**Verwendung:**

Zur Aufnahme von Werkzeugen mit Zylinderschaft in Spannzangen.

Application:

For mounting straight-shank tools in collets.

Application:

Destiné à recevoir les outils avec les queues de forme cylindrique dans les pinces de serrage.

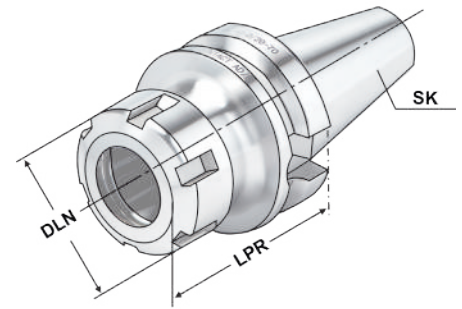

3

ISO
7388-2
DCForm
JD/JF
(AD/B)
≤ 3µm
G2.5
25.000
min⁻¹ISO
15488
13.04

Bestell-Nr. Order no. Référence	SK	DCONWS Spannbereich Capacity Capacité	Typ	LPR	DLN	THID
DC.305.02.10*	BT-DC 30	1 - 10	426E ER 16	70	32	M10 x 1,5
DC.305.02.16*	BT-DC 30	2 - 16	430E ER 25	70	42	M16 x 2,0
DC.305.02.20*	BT-DC 30	2 - 20	470E ER 32	70	50	M16 x 2,0
DC.305.02.26*	BT-DC 30	3 - 26	472E ER 40	70	63	M16 x 2,0
DC.406.02.10	BT-DC 40	1 - 10	426E ER 16	63	32	M10 x 1,5
DC.406.02.16	BT-DC 40	2 - 16	430E ER 25	60	42	M16 x 2,0
DC.406.02.20	BT-DC 40	2 - 20	470E ER 32	70	50	M16 x 2,0
DC.406.02.26	BT-DC 40	3 - 26	472E ER 40	80	63	M16 x 2,0
DC.406.02.10.1	BT-DC 40	1 - 10	426E ER 16	100	32	M10 x 1,5
DC.406.02.16.1	BT-DC 40	2 - 16	430E ER 25	100	42	M16 x 2,0
DC.406.02.20.1	BT-DC 40	2 - 20	470E ER 32	100	50	M16 x 2,0
DC.406.02.26.1	BT-DC 40	3 - 26	472E ER 40	100	63	M16 x 2,0
DC.406.02.10.2	BT-DC 40	1 - 10	426E ER 16	160	32	M10 x 1,5
DC.406.02.16.2	BT-DC 40	2 - 16	430E ER 25	160	42	M16 x 2,0
DC.406.02.20.2	BT-DC 40	2 - 20	470E ER 32	160	50	M16 x 2,0
DC.406.02.26.2	BT-DC 40	3 - 26	472E ER 40	160	63	M16 x 2,0

* Form JD (AD)

* Form JD (AD)

* Form JD (AD)

Lieferumfang: Mit gewichteter Spannmutter
Delivery: With balanced clamping nut
Livraison: Avec écrou de serrage équilibré

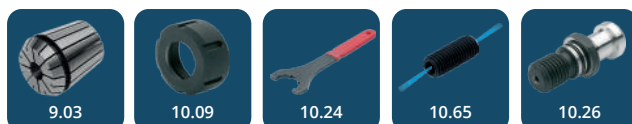



Precision collet chuck ER for collets ISO 15488 (DIN 6499) ER-system

Mandrin à pinces ER de précision pour pinces ISO 15488 (DIN 6499) système ER



Verwendung:
Zur Aufnahme von Werkzeugen mit Zylinderschaft in 3 µm-Spannzangen.

Application:
For mounting straight-shank tools in 3 µm-collets.

Application:
Pour le serrage d'outils avec queue cylindrique dans des pinces de serrage 3 µm.

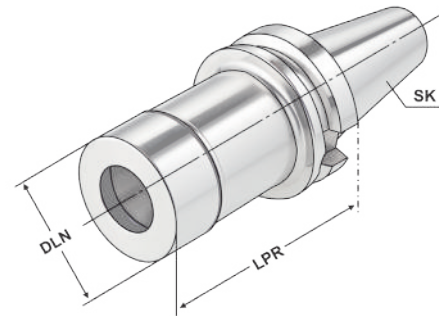

Bestell-Nr. Order no. Référence	SK	DCONWS Spannbereich Capacity Capacité	Typ	LPR	LB	DLN	THID
DC.305.P2.20.070	BT-DC 30	2 - 20	470E ER 32	70	48	50	M16 x 2,0
DC.405.P2.20.070	BT-DC 40	2 - 20	470E ER 32	70	43	50	M16 x 2,0
DC.405.P2.20.100	BT-DC 40	2 - 20	470E ER 32	100	73	50	M16 x 2,0

Vorteile:

Exzellente Rundlaufgenauigkeit im System (Futter + Spannzange + Spannmutter)
Extreme Haltekräfte (erhöht die Haltekraft um mindestens 60 % im Vergleich zu Standard ER-Futter)
Glatte Spannmutter ohne Nuten für Hochgeschwindigkeitsbearbeitung

Advantages:

Excellent concentricity in the system (chuck + collet + clamping nut)
Extremely strong holding force (increases the holding power by at least 60% compared to standard ER chuck)
Plain clamping nut without grooves for high speed machining

Avantages:

Excellente précision de concentricité dans le système (mandrin + pince de serrage + écrou de serrage)
La force de maintien extrême (augmente la force de maintien d'au moins à 60% par rapport aux mandrins standards ER)
Écrou de serrage lisse sans rainures pour l'usinage à haute vitesse

Hinweis:

Nur das Nennmaß DCONWS kann gespannt werden.

Note:

Only nominal size DCONWS can be clamped.

Observation:

Seulement la dimension nominale DCONWS peut être serrée.

Lieferumfang:

Inklusive Präzisions-Spannmutter

Delivery:

With precision clamping nut

Livraison:

Avec écrou de serrage de précision



High Performance Milling Chuck | HKS-system
Mandrin de serrage à haute performance | Système HKS



Verwendung:
 Zur Aufnahme von Werkzeugen mit Zylinderschaft nach DIN 1835 Form A+B+E und DIN 6535 Form HB+HE

Application:
 For mounting straight-shank tools acc. DIN 1835 form A+B+E and DIN 6535 form HB+HE

Application:
 Destiné à recevoir les outils avec les queues de forme cylindrique suivant DIN 1835 en forme A+B+E et DIN 6535 en forme HB+HE

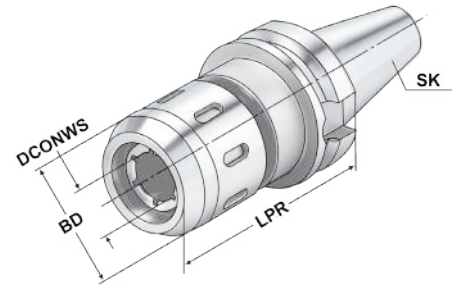

3

ISO 7388-2 DC	Form JD/JF (AD/B)	$\leq 3\mu\text{m}$	G6.3 15.000 min ⁻¹	HKS
---------------	-------------------	---------------------	-------------------------------	-----

13.04

Bestell-Nr. Order no. Référence	SK	DCONWS Spannbereich Capacity Capacité	Typ	DCONWS	LPR	BD
DC.406.64.20	BT-DC 40	3 – 20	HKS 20	20	90	53
DC.406.64.25	BT-DC 40	3 – 25	HKS 25	25	90	63
DC.406.64.32	BT-DC 40	3 – 32	HKS 32	32	90	68

Größe Size Taille	20mm	25mm	32mm
Anzugsmoment Clamping torque Couple	50-70 Nm	80-100 Nm	80-100 Nm
Spannkraft Clamping force Tension	780 Nm	2000 Nm	2000 Nm

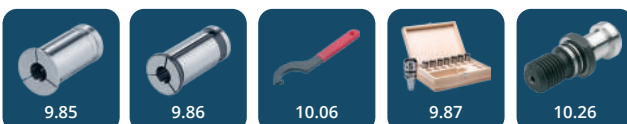

RELEASE THE BEAST



3



Verwendung:
 Zum Spannen von zylindrischen Werkzeugschäften mit seitlicher Spannfläche nach DIN 1835 Form B (Weldon).

Application:
 For mounting straight-shank tools with lateral flat according to DIN 1835 form B (Weldon).

Application:
 Pour le serrage d'outils avec queue cylindrique et avec méplat de serrage latérale suivant DIN 1835 forme B (Weldon).

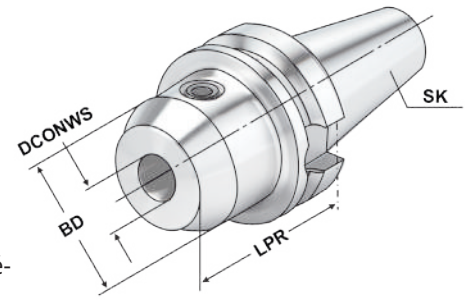

ISO 7388-2 DC Form JD/JF (AD/B) $\leq 3\mu\text{m}$ G2.5 25.000 min⁻¹ DIN 1835-B H4 13.04

Bestell-Nr. Order no. Référence	SK	DCONWS	TDCON	LPR	BD
DC.305.04.06*	BT-DC 30	6	H4	50	25
DC.305.04.08*	BT-DC 30	8	H4	50	28
DC.305.04.10*	BT-DC 30	10	H4	50	35
DC.305.04.12*	BT-DC 30	12	H4	50	42
DC.305.04.14*	BT-DC 30	14	H4	50	44
DC.305.04.16*	BT-DC 30	16	H4	63	48
DC.305.04.18*	BT-DC 30	18	H4	63	50
DC.305.04.20*	BT-DC 30	20	H4	63	52
DC.406.04.06	BT-DC 40	6	H4	50	25
DC.406.04.08	BT-DC 40	8	H4	50	28
DC.406.04.10	BT-DC 40	10	H4	63	35
DC.406.04.12	BT-DC 40	12	H4	63	42
DC.406.04.14	BT-DC 40	14	H4	63	44
DC.406.04.16	BT-DC 40	16	H4	63	48
DC.406.04.18	BT-DC 40	18	H4	63	50
DC.406.04.20	BT-DC 40	20	H4	63	52
DC.406.04.25	BT-DC 40	25	H4	90	65
DC.406.04.32	BT-DC 40	32	H4	100	72
DC.406.04.40	BT-DC 40	40	H4	120	80
DC.406.04.06.1	BT-DC 40	6	H4	100	25
DC.406.04.08.1	BT-DC 40	8	H4	100	28
DC.406.04.10.1	BT-DC 40	10	H4	100	35
DC.406.04.12.1	BT-DC 40	12	H4	100	42
DC.406.04.14.1	BT-DC 40	14	H4	100	44
DC.406.04.16.1	BT-DC 40	16	H4	100	48
DC.406.04.18.1	BT-DC 40	18	H4	100	50
DC.406.04.20.1	BT-DC 40	20	H4	100	52

* Form JD (AD)
 * Form JD (AD)
 * Form JD (AD)



End mill holders DIN 6359 with coolant channels for end mills DIN 1835-B
Porte-fraises DIN 6359 avec canaux d'arrosage pour queues cylindriques DIN 1835-B



Verwendung:
Zum Spannen von zylindrischen Werkzeugschäften mit seitlicher Spannfläche nach DIN 1835 Form B (Weldon). Mit Kühlkanälen für optimale Kühlung der Werkzeugschneide.

Application:
For mounting straight-shank tools with lateral flat according to DIN 1835 form B (Weldon). With coolant channels for optimal coolant at the cutting edge.

Application:
Pour le serrage d'outils avec queue cylindrique et avec méplat de serrage latéral suivant DIN 1835 forme B (Weldon). Avec canaux d'arrosage pour refroidissement optimal des coupes.

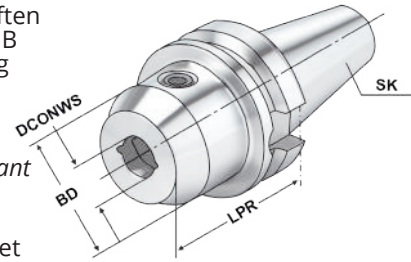

3

ISO 7388-2 DC	Form JD/JF (AD/B)	≤ 3µm	G2.5 25.000 min ⁻¹	DIN 1835-B	H4		13.04
---------------	-------------------	-------	-------------------------------	------------	----	--	-------

Bestell-Nr. Order no. Référence	SK	DCONWS	TDCON	LPR	BD
DC.406.04.06.K	BT-DC 40	6	H4	50	25
DC.406.04.08.K	BT-DC 40	8	H4	50	28
DC.406.04.10.K	BT-DC 40	10	H4	63	35
DC.406.04.12.K	BT-DC 40	12	H4	63	42
DC.406.04.14.K	BT-DC 40	14	H4	63	44
DC.406.04.16.K	BT-DC 40	16	H4	63	48
DC.406.04.18.K	BT-DC 40	18	H4	63	50
DC.406.04.20.K	BT-DC 40	20	H4	63	52

Hinweis: Ab DCONWS = 25 mit zwei Spannschrauben
DCONWS = 6 bis 18 mit zwei Kühlkanälen
DCONWS = 20 bis 20 mit vier Kühlkanälen
Für Werkzeuge mit innerer Kühlmittelzufuhr muss ein O-Ring eingesetzt werden.

Note: From DCONWS = 25 on two clamping screws
DCONWS = 6 to 18 with two coolant channels
DCONWS = 20 to 20 with four coolant channels
For tools with through coolant an O-ring must be used.

Observation: A partir de DCONWS = 25 avec deux vis de serrage
DCONWS = 6 bis 18 avec deux canaux d'arrosage
DCONWS = 20 bis 20 avec quatre canaux d'arrosage
Pour outils avec arrosage interne il faut utiliser un joint torique.

Lieferumfang: Mit Spannschraube und O-Ring
Delivery: With clamping screw and O-ring
Livraison: Avec vis de serrage et joint torique





Verwendung:
Zur Aufnahme von Werkzeugen mit Morsekegelschaft und Austreibblappen nach DIN 228-1 Form B.

Application:
For mounting tools with Morse taper shank and tang according to DIN 228-1 form B.

Application:
Pour le serrage d'outils avec queue cône Morse et tenon suivant DIN 228-1 forme B.

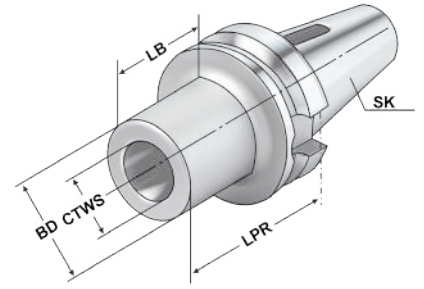

3

ISO
7388-2
DC

Form
JD/JF
(AD/B)

≤ 5µm

G6.3
15.000
min⁻¹

DIN
6383

AT5

Bestell-Nr. Order no. Référence	SK	CTWS	TDCON	LPR	BD	LB
DC.305.07.01*	BT-DC 30	1	AT5	45	25	23
DC.305.07.02*	BT-DC 30	2	AT5	60	32	38
DC.305.07.03*	BT-DC 30	3	AT5	75	40	53
DC.406.07.01	BT-DC 40	1	AT5	50	25	23
DC.406.07.02	BT-DC 40	2	AT5	50	32	23
DC.406.07.03	BT-DC 40	3	AT5	70	40	43
DC.406.07.04	BT-DC 40	4	AT5	95	48	68

* Form JD (AD)
* Form JD (AD)
* Form JD (AD)

Gewuchtete Ausführung

Balanced type
Type équilibré



Bestell-Nr. Order no. Référence	Abmessung Size Dimension
---------------------------------------	--------------------------------

Wuchten auf G 2,5 von vorgewuchteten Kemmler-Werkzeugen

Balancing at G 2.5 of pre-balanced Kemmler-tools
Équilibrage sur G 2,5 d'outils Kemmler pré-équilibrés

W25 **Ohne Wuchtprotokoll**
Without balancing report
Sans protocole d'équilibrage

W25.2 **Mit Wuchtprotokoll**
With balancing report
Avec protocole d'équilibrage

Wuchten von nicht vorgewuchteten Werkzeugen
Balancing of unbalanced tools
Équilibrage d'outils non-équilibrés

W25.1 **Ohne Wuchtprotokoll**
Without balancing report
Sans protocole d'équilibrage





CNC-Drill chucks for clockwise and counter clockwise rotation
Mandrins de perçage CNC pour rotation gauche-droite

Dual Contact ISO 7388-2



Verwendung:
Zur Aufnahme von Werkzeugen mit Zylinderschaft.
Application:
For mounting tools with straight shanks.
Application:
Pour le serrage d'outils avec queue cylindrique.

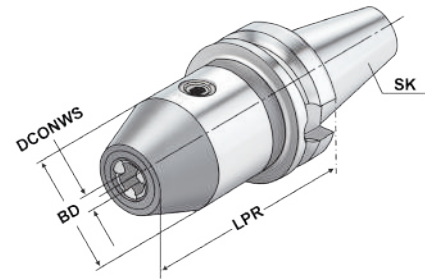

ISO 7388-2 DC Form JD/JF (AD/B) $\leq 30\mu\text{m}$ G6.3 15.000 min⁻¹ 13.04

Bestell-Nr. Order no. Référence	SK	DCONWS Spannbereich Capacity Capacité	LPR	BD	DRVS
DC.305.15.13*	BT-DC 30	1,0 – 13	93	50	6
DC.305.15.16*	BT-DC 30	2,5 – 16	98	50	6
DC.406.15.13	BT-DC 40	1,0 – 13	98	50	6
DC.406.15.16	BT-DC 40	2,5 – 16	103	50	6

* Form JD (AD)
* Form JD (AD)
* Form JD (AD)

Hinweis: Hohe Präzision und Rundlaufgenauigkeit von $\leq 0,03$ mm. Sichere Spannung des Werkzeuges durch mechanische Spannkraftverstärkung. Kein selbständiges Lösen der Spannung während der Bearbeitung bei Links- oder Rechtslauf, sowie bei Spindelstop. Spannen und Lösen mit Sechskantschlüssel.

Note: High precision and accurate concentricity of ≤ 0.03 mm. Secure gripping of the tool through mechanical amplification of the clamping force. No automatic slackening of the clamping force while machining with either clockwise or counter clockwise rotation or on spindle stop. Clamping and releasing effected by means of an Allen wrench.

Observation: Précision élevée et exactitude de circularité de $\leq 0,03$ mm. Serrage sûr de l'outil grâce à l'amplification de la force de serrage. Pas de desserrage intempestif en cours d'usinage lors de la rotation la gauche ou la droite, de même qu'en cas d'arrêt de la broche. Serrage et desserrage en utilisant un clé sur à fourche.

Lieferumfang: Ohne Spannschlüssel
Delivery: Without wrench
Livraison: Sans clé de serrage





3



Verwendung:
Zur Aufnahme von Walzen-, Walzenstirnfräsern oder Messerköpfen mit Längs- oder Quernut.

Application:
For mounting milling cutters with transverse or longitudinal groove.

Application:
Destiné à recevoir les porte-fraises, les fraises cylindriques ou les têtes de fraisage avec rainure longitudinale et transversale.

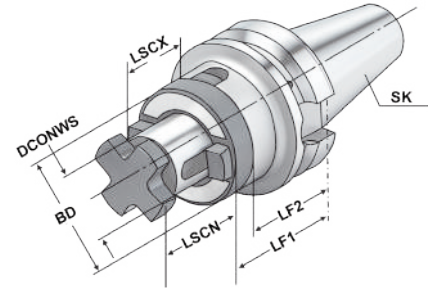

ISO 7388-2 DC	Form JD/JF (AD/B)	$\leq 5\mu\text{m}$	G6.3 15.000 min ⁻¹	DIN 6358	h6
---------------	-------------------	---------------------	-------------------------------	----------	----

Bestell-Nr. Order no. Référence	SK	DCONWS	TDCON	LF1	LF2	LSCN	LSCX	BD
DC.305.10.16*	BT-DC 30	16	h6	45	35	17	27	32
DC.305.10.22*	BT-DC 30	22	h6	47	35	19	31	40
DC.305.10.27*	BT-DC 30	27	h6	49	35	21	33	48
DC.406.10.16	BT-DC 40	16	h6	55	45	17	27	32
DC.406.10.22	BT-DC 40	22	h6	55	43	19	31	40
DC.406.10.27	BT-DC 40	27	h6	55	43	21	33	48

* Form JD (AD)
* Form JD (AD)
* Form JD (AD)

Lieferumfang: Mit Fräseranzugsschraube, Mitnehmerring und Passfeder
Delivery: With retaining screw, driving ring and feather key
Livraison: Avec vis de serrage, bague d'entraînement et clavette





Shell mill holders DIN 6357 with enlarged contact face and coolant exit bores on the end face
 Porte-fraises à trou lisse DIN 6357 avec face de contact élargie et conduits pour l'arrosage frontal



Verwendung:
 Zur Aufnahme von Messerköpfen und Fräsern mit Quernut.

Application:
 For mounting milling cutters with transversal groove.

Application:
 Destiné à recevoir les fraises et les fraises avec des rainures transversales.

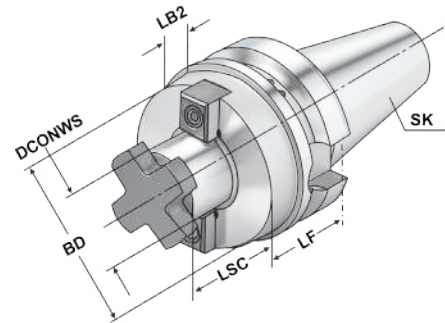

3

ISO 7388-2 DC Form JD/JF (AD/B) ≤ 5µm G2.5 25.000 min⁻¹ DIN 6357 h6

Bestell-Nr. Order no. Référence	SK	DCONWS	TDCON	LF	LSC	LB2	BD
DC.305.11.16*	BT-DC 30	16	h6	40	17	18	38
DC.305.11.22*	BT-DC 30	22	h6	40	19	18	48
DC.305.11.27*	BT-DC 30	27	h6	40	21	18	58
DC.305.11.32*	BT-DC 30	32	h6	50	24	28	78
DC.406.11.16	BT-DC 40	16	h6	40	17	13	38
DC.406.11.22	BT-DC 40	22	h6	40	19	13	48
DC.406.11.27	BT-DC 40	27	h6	40	21	13	58
DC.406.11.32	BT-DC 40	32	h6	50	24	23	78
DC.406.11.40	BT-DC 40	40	h6	50	27	23	88
DC.406.11.16.1	BT-DC 40	16	h6	100	17	73	38
DC.406.11.22.1	BT-DC 40	22	h6	100	19	73	48
DC.406.11.27.1	BT-DC 40	27	h6	100	21	73	58

* Form JD (AD) BT-DC 30 ohne Kühlkanalbohrungen an der Stirnseite
 * Form JD (AD) BT-DC 30 without coolant exit bores on the end face
 * Form JD (AD) BT-DC 30 sans alésages pour l'arrosage frontal



DCONWS = 40 Für große Planfräser mit vier zusätzlichen Gewindebohrungen nach DIN 2079.
 For large diameter face mill cutters with four additional threaded holes according to DIN 2079.
 Pour fraises à surfacer à grands diamètres avec 4 taraudages supplémentaires suivant DIN 2079.

Lieferumfang: Mit Mitnehmersteinen, Kreuzschraube und Zylinderkopfschraube nach DIN 912 für Fräser mit innerer Kühlmittelzufuhr.

Delivery: With drivers, cross head retaining screw and cylinder head retaining screw for cutters with central coolant.

Livraison: Avec tenons, une vis cruciforme et une vis à tête cylindrique suivant DIN 912 pour fraises avec arrosage central.



Quick change tapping chucks with length compensation on compression and expansion
 Mandrins de taraudage à changement rapide avec compensation longitudinale à la compression et traction



Verwendung:
 Zur Aufnahme von Schnellwechsel-Einsätzen für Gewindebohrer.

Application:
 For the chucking of quick change adaptors for taps.

Application:
 Pour le serrage d'adaptateurs porte-tarands à changement rapide.

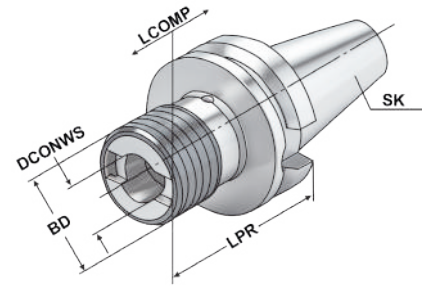

3

ISO
7388-2
DC

Form
J
(A)



13.04

Bestell-Nr. Order no. Référence	SK	Spannbereich Capacity Capacité	SZID	DCONWS	LPR	BD	LCOMP
DC.405.16.12	BT-DC 40	M3 – M14	1	19	65	38	7
DC.405.16.20	BT-DC 40	M5 – M22	2	31	93	54	12

Hinweis: Für Bearbeitungszentren ohne Synchronspindel.
Note: For machining centres without synchronous spindle.
Observation: Pour centres d'usinage sans broche synchrone.





Tapping chucks for synchronisation for collets DIN 6499 (ISO 15488) ER-system

Mandrins de taraudage pour synchronisation pour pinces DIN 6499 (ISO 15488) système ER



Verwendung:
Für Bearbeitungszentren mit Synchronspindel.
Application:
For machining centres with synchronous spindle.
Application:
Pour centres d'usinage avec broche synchrone.

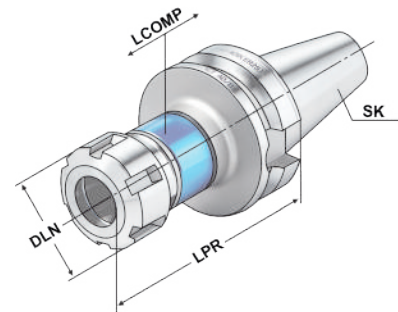

ISO 7388-2 DC Form JD/JF (AD/B) ≤ 60µm G6.3 15.000 min⁻¹ ISO 15488 13.04

Bestell-Nr. Order no. Référence	SK	DCONWS Spannbereich Capacity Capacité	Typ	LPR	DLN	LCOMP
DC.406.16.02.10*	BT-DC 40	M3 - M12	426E ER 16 SW25	81	28	0,5
DC.406.16.02.16	BT-DC 40	M3 - M20	430E ER 25	89	42	0,5
DC.406.16.02.20	BT-DC 40	M3 - M27	470E ER 32	110	50	0,5

* **Sechskantmutter**
* Hexagonal clamping nut
* Écrous hexagonal

Hinweis:

- Synchro-Gewindeschneidfutter kompensieren Synchronisationsfehler.
- Minimallängenausgleich in Druck- und Zugrichtung zwischen Synchronspindel und Gewindebohrer reduziert zu hohe Gewindeflankenreibungskräfte.
- Reduziert eventuelle Axialkraftherhöhung während des Schneidzyklus auf ein Minimum.
- Geeignet für Innenkühlung.
- Kühlmitteldruck max. 100 bar.

Note:

- Synchro tapping chucks compensate synchronisation errors.
- Minimal length compensation on compression and expansion balances very small pitch differences between synchro spindle and tap, which can cause high frictional forces on the thread flanks.
- A possible increase of axial force during the tapping process is reduced to a minimum.
- Suitable for internal coolant.
- Coolant pressure up to max. 100 bar.

Observation:

- Mandrins de taraudage version „synchro“ compensent les erreurs éventuelles de synchronisation.
- Compensation longitudinale minimale à la compression et traction entre la broche synchronisée et le taraud réduit la friction au niveau des flancs de filets.
- Réduit au minimum les efforts éventuelles axiaux lors du cycle de taraudage.
- Approprié pour la lubrification centrale.
- Pression de lubrification max. 100 bar.

Lieferumfang: Mit gewuchteter Spannmutter
Delivery: With balanced clamping nut
Livraison: Avec écrou de serrage équilibré



3



Verwendung:
Zur Herstellung von Sonderwerkzeugen.
Application:
For the manufacturing of special tools.
Application:
Pour la fabrication d'outils spéciaux.

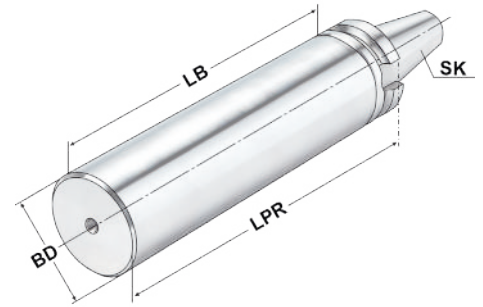

ISO
7388-2
DC

Form
J
(A)

Bestell-Nr. Order no. Référence	SK	BD	LB	LPR
DC.305.17.40	BT-DC 30	40,5	138	160
DC.405.17.63	BT-DC 40	63	215	250

Ausführung: Steilkegel und Bund gehärtet und geschliffen. Schaft weich zur weiteren Bearbeitung.
Version: *Cone and flange hardened and grinded. Soft body for later processing.*
Version: Cône et collerette durcis et rectifiés. Corps doux pour un usinage ultérieur.





Hydraulic expansion chucks
Mandrins expansibles hydrauliques

Dual Contact ISO 7388-2



Verwendung:
Zur Aufnahme von Werkzeugen mit Zylinderschaft nach DIN 1835 Form A+B+E und DIN 6535 Form HB+HE (größer Ø 20 mm nur mit Reduzierung).

Application:
For mounting straight-shank tools acc. DIN 1835 form A+B+E and DIN 6535 form HB+HE (larger than Ø 20 mm only with reduction sleeve).

Application:
Pour le serrage d'outils avec queue cylindrique suivant DIN 1835 forme A+B+E et DIN 6535 forme HB+HE (à partir de Ø 20 mm seulement avec réduction).

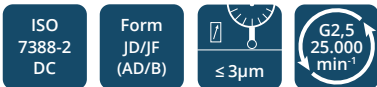
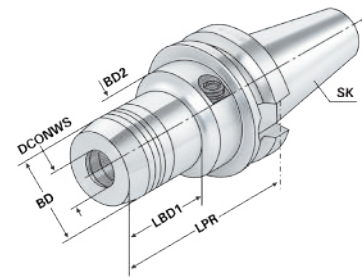

Bestell-Nr. Order no. Référence	SK	DCONWS	LPR	BD	BD2	LSCX	ADJRGA	LBD1	DRVS	THID
DC.305.H06 *	BT-DC 30	6	60	26	45	37	10	33	5	M6x1
DC.305.H08 *	BT-DC 30	8	64	28	45	37	10	29	5	M6x1
DC.305.H10 *	BT-DC 30	10	64	30	45	42	10	37	5	M6x1
DC.305.H12 *	BT-DC 30	12	72	32	45	47	10	43	5	M8x1
DC.305.H14 *	BT-DC 30	14	70	34	45	47	10	45	5	M10x1
DC.305.H16 *	BT-DC 30	16	90	38	45	52	10	52	5	M12x1
DC.305.H18 *	BT-DC 30	18	90	40	45	52	10	52	5	M12x1
DC.305.H20 *	BT-DC 30	20	90	42	45	52	10	52	5	M12x1
DC.405.H06	BT-DC 40	6	90	26	50	37	10	43	5	M6x1
DC.405.H08	BT-DC 40	8	90	28	50	37	10	43,5	5	M6x1
DC.405.H10	BT-DC 40	10	90	30	50	42	10	44	5	M8x1
DC.405.H12	BT-DC 40	12	90	32	50	47	10	44,5	5	M8x1
DC.405.H14	BT-DC 40	14	90	34	50	47	10	47,5	5	M10x1
DC.405.H16	BT-DC 40	16	90	38	50	52	10	47,5	5	M12x1
DC.405.H18	BT-DC 40	18	90	40	50	52	10	47,5	5	M12x1
DC.405.H20	BT-DC 40	20	90	42	50	52	10	47,5	5	M12x1
DC.405.H25	BT-DC 40	25	90	50	50	58	10	51	6	M12x1
DC.405.H32	BT-DC 40	32	110	60	60	64	10	81,5	6	M12x1

LSCX = Einspannlänge, max.
LSCX = Clamping depth, max.
LSCX = Profondeur d'insertion, max.

ADJRGA = Verstellweg, max.
ADJRGA = Length adjustment range, max.
ADJRGA = Course de réglage, max.

* Form JD (AD)
* Form JD (AD)
* Form JD (AD)

Lieferumfang: Ohne Spannschlüssel
Delivery: Without wrench
Livraison: Sans clé de serrage



Spannkraft-Prüfgerät für Hydrodehnspannfutter - Seite 12.59
Clamping force proofing instrument for hydraulic chucks - page 12.59
Appareil de contrôle des forces de serrage pour mandrin expansibles hydrauliques - page 12.59





Verwendung:
Zur Aufnahme von Einschraubfräser mit Gewinde.

Application:
For mounting screw-in cutters with thread.

Application:
Pour le serrage de fraises à queue filetée.

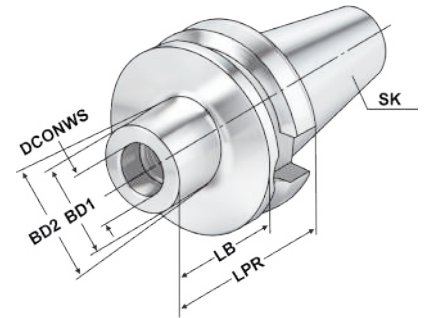

3

ISO 7388-2 DC

Form JD/JF (AD/B)

≤ 3µm

G2.5 25.000 min⁻¹

H7

Bestell-Nr. Order no. Référence	SK	THSZWS	DCONWS	BD1	BD2	LPR	LB
DC.406.06.12	BT-DC 40	M12	12,5	21	24	52	25
DC.406.06.12.2	BT-DC 40	M12	12,5	21	31	102	75
DC.406.06.12.3	BT-DC 40	M12	12,5	21	33	127	100
DC.406.06.16	BT-DC 40	M16	17	29	29	52	25
DC.406.06.16.1	BT-DC 40	M16	17	29	34	77	50
DC.406.06.16.2	BT-DC 40	M16	17	29	34	102	75
DC.406.06.16.3	BT-DC 40	M16	17	29	36	127	100

Empfohlenes Anzugsmoment
Recommended tightening torques
Torques de serrage recommandés

M6	10 Nm
M8	25 Nm
M10	40 Nm
M12	60 Nm
M16	50 Nm





Shrink chucks 4,5° for mounting of solid carbide and HSS-tool shanks

Mandrins de frettage 4,5° pour le serrage de queues d'outils carbures de type HM et HSS



Verwendung:
Zur Aufnahme von Werkzeugen mit Zylinderschaft.

Application:
For mounting straight-shank tools.

Application:
Pour le serrage d'outils avec queue cylindrique.

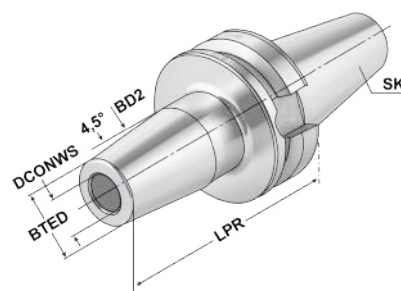

ISO 7388-2 DC Form JD/JF (AD/B) ≤ 3µm G2.5 25.000 min⁻¹ h6

Bestell-Nr. Order no. Référence	SK	DCONWS	TDCON	LPR	BTED	BD	LSCN	LSCX	ADJRG	THID
DC.305.70.03*	BT-DC 30	3	h4	80	11	15	6	-	-	-
DC.305.70.04*	BT-DC 30	4	h4	80	14	22	8	-	5	-
DC.305.70.05*	BT-DC 30	5	h4	80	16	22	10	-	5	-
DC.305.70.06*	BT-DC 30	6	h6	80	21	27	22	36	10	M5x0,8
DC.305.70.08*	BT-DC 30	8	h6	80	21	27	26	36	10	M6x1
DC.305.70.10*	BT-DC 30	10	h6	90	24	32	31	41	10	M8x1
DC.305.70.12*	BT-DC 30	12	h6	90	24	32	36	46	10	M10x1
DC.305.70.14*	BT-DC 30	14	h6	90	27	34	36	46	10	M10x1
DC.305.70.16*	BT-DC 30	16	h6	90	27	34	39	49	10	M12x1
DC.305.70.18*	BT-DC 30	18	h6	90	33	42	39	49	10	M12x1
DC.305.70.20*	BT-DC 30	20	h6	90	33	42	41	51	10	M16x1
DC.406.70.03	BT-DC 40	3	h4	80	11	15	6	-	-	-
DC.406.70.04	BT-DC 40	4	h4	80	14	22	8	-	-	-
DC.406.70.05	BT-DC 40	5	h4	80	16	22	10	-	-	-
DC.406.70.06	BT-DC 40	6	h6	90	21	27	22	36	10	M5x0,8
DC.406.70.08	BT-DC 40	8	h6	90	21	27	26	36	10	M6x1
DC.406.70.10	BT-DC 40	10	h6	90	24	32	31	41	10	M8x1
DC.406.70.12	BT-DC 40	12	h6	90	24	32	36	46	10	M10x1
DC.406.70.14	BT-DC 40	14	h6	90	27	34	36	46	10	M10x1
DC.406.70.16	BT-DC 40	16	h6	90	27	34	39	49	10	M12x1
DC.406.70.18	BT-DC 40	18	h6	90	33	42	39	49	10	M12x1
DC.406.70.20	BT-DC 40	20	h6	90	33	42	41	51	10	M16x1
DC.406.70.25	BT-DC 40	25	h6	100	44	53	47	57	10	M16x1
DC.406.70.32	BT-DC 40	32	h6	100	44	53	51	61	10	M16x1
DC.406.70.06.1	BT-DC 40	6	h6	120	21	27	22	36	10	M5x0,8
DC.406.70.08.1	BT-DC 40	8	h6	120	21	27	26	36	10	M6x1
DC.406.70.10.1	BT-DC 40	10	h6	120	24	32	31	41	10	M8x1
DC.406.70.12.1	BT-DC 40	12	h6	120	24	32	36	46	10	M10x1
DC.406.70.14.1	BT-DC 40	14	h6	120	27	34	36	46	10	M10x1
DC.406.70.16.1	BT-DC 40	16	h6	120	27	34	39	49	10	M12x1
DC.406.70.20.1	BT-DC 40	20	h6	120	33	42	41	51	10	M16x1

* Form JD/AD
* Form JD/AD
* Form JD/AD

LSCX = Einspannlänge, max.
LSCX = Clamping depth, max.
LSCX = Profondeur d'insertion, max.

ADJRG = Verstellweg, max.
ADJRG = Length adjustment range, max.
ADJRG = Course de réglage, max.



Für Ø 3, 4 und 5 mm nur Hartmetallschäfte verwenden!
For Ø 3, 4 and 5 mm only solid carbide tool shanks must be used!
Pour Ø 3, 4 et 5 mm il faut seulement utiliser de queues d'outils carbures de type HM!

3



Verwendung:
Zur Abnahme von Werkzeugmaschinen gemäß ISO-Empfehlung R230 oder zur Überprüfung der Werkzeugspindel.

Application:
For the inspection of machine tools according to ISO recommendation R230 or for testing the tool spindle.

Application:
Pour l'inspection de machine-outils suite à la recommandation ISO R230 ou pour la vérification de la broche.



Bestell-Nr. Order no. Référence	SK	LPR	BD	Toleranz Tolerance Tolérance	max. Rundlaufabweichung max. concentricity deviation Faux-rond max.
DC.305.18.32	BT-DC 30	300	32	0,003	0,003
DC.405.18.40	BT-DC 40	300	40	0,003	0,003

Lieferumfang: Auslieferung mit Prüfprotokoll
Delivery: *Delivery with test certificate*
Livraison: Livraison avec rapport d'essais

Holzkasten für Kontrolldorne

Wooden box for test arbors
Coffret en bois pour mandrins de contrôle



Verwendung:
Zur Aufbewahrung von Kontrolldornen.

Application:
For the storage of test arbors.

Application:
Pour la conservation de mandrins de contrôle.



Bestell-Nr. Order no. Référence	Abmessung Size Dimension	für Kegelgrößen for cones pour cônes
701.18	460 × 130 × 115	BT 30 / 40 / 50

Steep taper toolholders with full face contact
 Porte-outils conique avec cône face

Dual Contact ISO 7388-2

Die Vorteile sind:

- Maschinenleistung kann voll genutzt werden
- Stabile und vergrößerte, vollständige Plananlage
- Weniger Vibrationen aufgrund der großen Plananlage
- Verbesserte Oberflächengüte und prozesssichere Maßhaltigkeit am Werkstück
- Höhere Standzeit der Schneidwerkzeuge
- Bessere Werkzeugwechsel-Wiederholgenauigkeit
- Kein Stabilitätsverlust bei hohen Spindeldrehzahlen

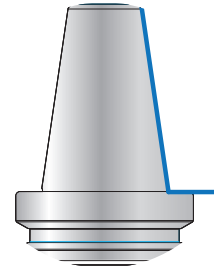

3

The advantages are:

- Machine performance can be used to the full extent
- Stable and bigger, complete full face contact
- Less vibrations due to large full face contact
- Better surface finish and higher reliability of processing
- Longer service life of the cutting tools
- Better tool change repeat accuracy
- No loss of stability at high spindle speeds



Les avantages sont:

- La rendement de machine peut être utilisée entièrement
- Cône face entière, stable et élargi
- Moins vibrations à cause de cône face élargi
- Finition de surface améliorée et tenue des cotes fiable de la pièce usinée
- Tenue de coupe prolongée
- Exactitude de changement d'outil améliorée
- Pas de perte de stabilité à grande vitesse de la broche



**WERKZEUGAUFNAHMEN
DIN 2080**

**TOOLHOLDERS
DIN 2080**

**PORTE-OUTILS
DIN 2080**

DIN 2080

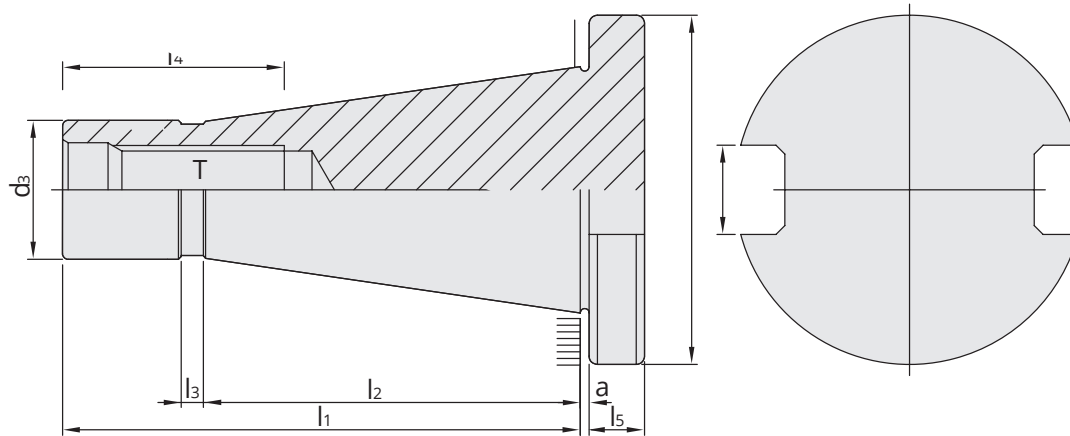

4

SK	D	d ₁	d ₂	d ₃	a	l ₁	l ₂	l ₃	l ₄	l ₅	T
	⁰ _{-0,4}		H12	min	±0.2					±0.15	
30	50	31,75	16,1	17,04	1,6	68,4	48,4	3	24	8	M12
40 ★	63	44,45	16,1	24,92	1,6	93,4	65,4	5	32	10	M16
50 ★	97,5	69,85	25,7	39,19	3,2	126,8	101,8	8	47	12	M24

- ★ Mit Kunststoff-Kantenschutzring
- ★ With plastic protection ring
- ★ Avec bague de protection en plastique

Vorgewuchtet G 6,3 15.000 min⁻¹
Pre-balanced
Pré-équilibré

G 2,5 Feinwuchten gegen Aufpreis
G 2.5 Fine balancing at extra charge
G 2,5 Equilibrage fin contre un supplément

Werkstoff: Legierter Einsatzstahl mit einer Zugfestigkeit im Kern von min. 950 N / mm². Einsatzgehärtet HRC 60 ± 2 (HV 700 ± 50), Härtetiefe 0,8 mm ± 0,2 mm, brüniert und präzisionsgeschliffen.

Genauigkeit: Kegelwinkel – Toleranzqualität < AT 3 nach DIN 7187 und DIN 2080.

Material: *Alloyed case-hardened steel, tensile core strength of min. 950 N / mm². Case hardened HRC 60 ± 2 (HV 700 ± 50), hardening depth 0.8 mm ± 0.2 mm, black-finished and precisely grinded.*

Accuracy: *Quality of taper < AT 3 according to DIN 7187 and DIN 2080.*

Matière: Acier de cémentation allié. Résistance à la traction dans le noyau de min 950 N / mm². Cémentation à HRC 60 ± 2 (HV 700 ± 50), profondeur de cémentation 0,8 mm ± 0,2 mm, bruni et rectifié précisément.

Précision: Qualité du cône < AT 3 selon DIN 7187 et DIN 2080.

Normative Verweise:
Normative references:
Références normatives:

DIN 2080-1:2011-11
Steilkegelschäfte für Werkzeuge und Spannzeuge

DIN 2080-1:2011-11
7/24 taper shanks for tools and clamping devices

DIN 2080-1:2011-11
Queues coniques 7/24 pour outils et dispositifs de serrage



Index
Sommaire

 4.05	 4.06	 4.07	 4.09
 4.10	 4.11	 4.12	 4.13
 4.14	 4.15	 4.16	 4.17
 4.18			
 4.19			

4

Collet chucks DIN 6391 for collets ISO 10897 (DIN 6388) OZ-system
Mandrins à pinces DIN 6391 pour pinces ISO 10897 (DIN 6388) système OZ



Verwendung:
Zur Aufnahme von Werkzeugen mit Zylinderschaft in Spannzangen.

Application:
For mounting straight-shank tools in collets.

Application:
Destiné à recevoir les outils avec les queues de forme cylindrique dans les pinces de serrage.

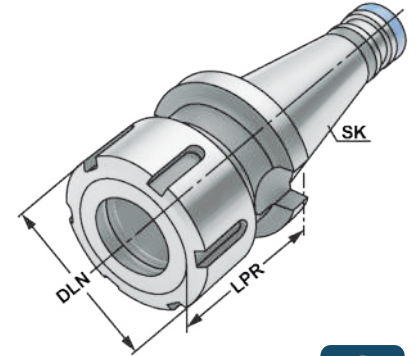

4



Bestell-Nr. Order no. Référence	SK	DCONWS Spannbereich Capacity Capacité	Typ	LPR	DLN	THID
301.01.16	SK 30	2 – 16	415E OZ 16	50	43	M16 x 2,0
401.01.16	SK 40	2 – 16	415E OZ 16	55	43	M16 x 2,0
401.01.25	SK 40	2 – 25	462E OZ 25	66	60	M16 x 2,0
401.01.32	SK 40	3 – 32	467E OZ 32	95	72	M16 x 2,0
501.01.25	SK 50	2 – 25	462E OZ 25	71	60	M16 x 2,0
501.01.32	SK 50	3 – 32	467E OZ 32	73	72	M16 x 2,0

Lieferumfang: Mit kugellagerter Spannmutter
Delivery: With ball bearing clamping nut
Livraison: Avec écrou de serrage à roulement à billes



ISO 15488 (DIN 6499) System ER

Collet chucks for collets ISO 15488 (DIN 6499) ER-system
Mandrins à pinces pour pinces ISO 15488 (DIN 6499) système ER



Verwendung:
Zur Aufnahme von Werkzeugen mit Zylinderschaft in Spannzangen.

Application:
For mounting straight-shank tools in collets.

Application:
Destiné à recevoir les outils avec les queues de forme cylindrique dans les pinces de serrage.

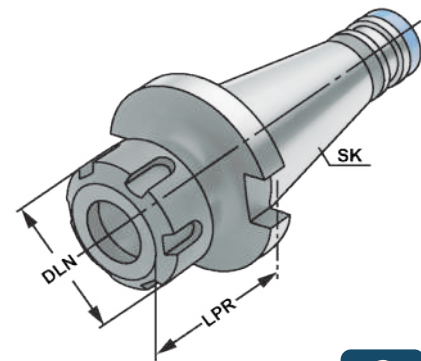

Bestell-Nr. Order no. Référence	SK	DCONWS Spannbereich Capacity Capacité	Typ	LPR	DLN	THID
301.02.16	SK 30	2 - 16	430E ER 25	50	42	M16 x 2,0
301.02.20	SK 30	2 - 20	470E ER 32	50	50	M16 x 2,0
401.02.16	SK 40	2 - 16	430E ER 25	50	42	M16 x 2,0
401.02.20	SK 40	2 - 20	470E ER 32	50	50	M16 x 2,0
401.02.26	SK 40	3 - 26	472E ER 40	80	63	M16 x 2,0
501.02.20	SK 50	2 - 20	470E ER 32	63	50	M16 x 2,0
501.02.26	SK 50	3 - 26	472E ER 40	63	63	M16 x 2,0

Lieferumfang: Mit gewuchteter Spannmutter
Delivery: With balanced clamping nut
Livraison: Avec écrou de serrage équilibré

Gewuchtete Ausführung



Balanced type
Type équilibré

Bestell-Nr. Order no. Référence	Abmessung Size Dimension
Wuchten auf G 2,5 von vorgewuchteten Kemmler-Werkzeugen Balancing at G 2.5 of pre-balanced Kemmler-tools Équilibrage sur G 2,5 d'outils Kemmler pré-équilibrés	
W25	Ohne Wuchtprotokoll Without balancing report Sans protocole d'équilibrage
W25.2	Mit Wuchtprotokoll With balancing report Avec protocole d'équilibrage
Wuchten von nicht vorgewuchteten Werkzeugen Balancing of unbalanced tools Équilibrage d'outils non-équilibrés	
W25.1	Ohne Wuchtprotokoll Without balancing report Sans protocole d'équilibrage



End mill holders DIN 6359 for end mills DIN 1835-B
 Porte-fraises DIN 6359 pour queues cylindriques DIN 1835-B



Verwendung:
 Zum Spannen von zylindrischen Werkzeugschäften mit seitlicher Spannfläche nach DIN 1835 Form B (Weldon).

Application:
 For mounting straight-shank tools with lateral flat according to DIN 1835 form B (Weldon).

Application:
 Pour le serrage d'outils avec queue cylindrique et avec méplat de serrage latérale suivant DIN 1835 forme B (Weldon).

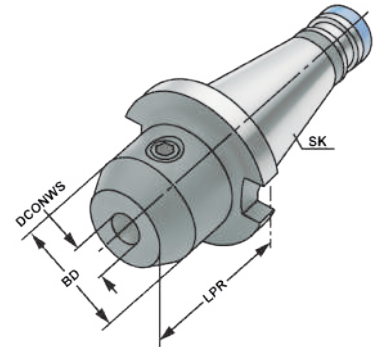

4

DIN 2080
Form AD
≤ 3µm
G6.3 15.000 min⁻¹
DIN 1835-B
H4

13.04

Bestell-Nr. Order no. Référence	SK	DCONWS	TDCON	LPR	BD
301.04.06	SK 30	6	H4	40	25
301.04.08	SK 30	8	H4	40	28
301.04.10	SK 30	10	H4	40	35
301.04.12	SK 30	12	H4	40	42
301.04.14	SK 30	14	H4	50	44
301.04.16	SK 30	16	H4	50	48
301.04.18	SK 30	18	H4	50	50
301.04.20	SK 30	20	H4	63	52
401.04.06	SK 40	6	H4	50	25
401.04.08	SK 40	8	H4	50	28
401.04.10	SK 40	10	H4	50	35
401.04.12	SK 40	12	H4	50	42
401.04.14	SK 40	14	H4	50	44
401.04.16	SK 40	16	H4	63	48
401.04.18	SK 40	18	H4	63	50
401.04.20	SK 40	20	H4	63	52
401.04.25	SK 40	25	H4	80	65
401.04.32	SK 40	32	H4	80	72
401.04.40	SK 40	40	H4	90	80

Hinweis: Ab DCONWS = 25 mit zwei Spannschrauben
Note: From DCONWS = 25 on two clamping screws
Observation: A partir de DCONWS = 25 avec deux vis de serrage

Lieferumfang: Mit Spannschraube
Delivery: With clamping screw
Livraison: Avec vis de serrage



End mill holders DIN 6359 for end mills DIN 1835-B

Porte-fraises DIN 6359 pour queues cylindriques DIN 1835-B

**Verwendung:**

Zum Spannen von zylindrischen Werkzeugschäften mit seitlicher Spannfläche nach DIN 1835 Form B (Weldon).

Application:

For mounting straight-shank tools with lateral flat according to DIN 1835 form B (Weldon).

Application:

Pour le serrage d'outils avec queue cylindrique et avec méplat de serrage latérale suivant DIN 1835 forme B (Weldon).

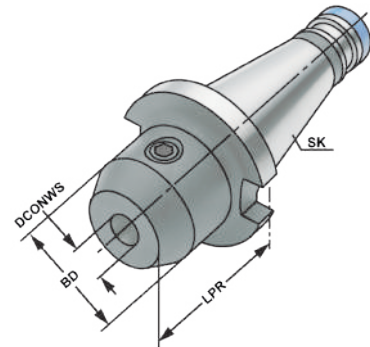

4

Bestell-Nr. Order no. Référence	SK	DCONWS	TDCON	LPR	BD
501.04.06	SK 50	6	H4	63	25
501.04.08	SK 50	8	H4	63	28
501.04.10	SK 50	10	H4	63	35
501.04.12	SK 50	12	H4	63	42
501.04.14	SK 50	14	H4	63	44
501.04.16	SK 50	16	H4	63	48
501.04.18	SK 50	18	H4	63	50
501.04.20	SK 50	20	H4	63	52
501.04.25	SK 50	25	H4	80	65
501.04.32	SK 50	32	H4	80	72
501.04.40	SK 50	40	H4	90	80

Hinweis: Ab DCONWS = 25 mit zwei Spannschrauben
Note: From DCONWS = 25 on two clamping screws
Observation: À partir de DCONWS = 25 avec deux vis de serrage

Lieferumfang: Mit Spannschraube
Delivery: With clamping screw
Livraison: Avec vis de serrage

Gewuchtete Ausführung**Balanced type
Type équilibré**

Bestell-Nr. Order no. Référence	Abmessung Size Dimension
Wuchten auf G 2,5 von vorgewuchteten Kemmler-Werkzeugen Balancing at G 2.5 of pre-balanced Kemmler-tools Équilibrage sur G 2,5 d'outils Kemmler pré-équilibrés	
W25	Ohne Wuchtprotokoll Without balancing report Sans protocole d'équilibrage
W25.2	Mit Wuchtprotokoll With balancing report Avec protocole d'équilibrage
Wuchten von nicht vorgewuchteten Werkzeugen Balancing of unbalanced tools Équilibrage d'outils non-équilibrés	
W25.1	Ohne Wuchtprotokoll Without balancing report Sans protocole d'équilibrage





Adaptor sleeves for MT with tang DIN 6383
Douilles de réduction pour CM à tenon DIN 6383



Verwendung:
Zur Aufnahme von Werkzeugen mit Morsekegelschaft und Austreibblappen nach DIN 228-1 Form B.

Application:
For mounting tools with Morse taper shank and tang according to DIN 228-1 form B.

Application:
Pour le serrage d'outils avec queue cône Morse et tenon suivant DIN 228-1 forme B.

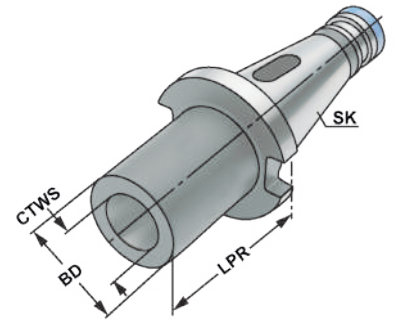

4

DIN 2080	Form AD	≤ 5µm	G6,3 15.000 min ⁻¹	DIN 6383	AT5
----------	---------	-------	-------------------------------	----------	-----

Bestell-Nr. Order no. Référence	SK	CTWS	TDCON	LPR	BD
301.07.01	SK 30	1	AT5	50	25
301.07.02	SK 30	2	AT5	50	32
301.07.03	SK 30	3	AT5	75	40
401.07.01	SK 40	1	AT5	50	25
401.07.02	SK 40	2	AT5	50	32
401.07.03	SK 40	3	AT5	65	40
401.07.04	SK 40	4	AT5	95	48
501.07.01	SK 50	1	AT5	45	25
501.07.02	SK 50	2	AT5	60	32
501.07.03	SK 50	3	AT5	65	40
501.07.04	SK 50	4	AT5	70	48
501.07.05	SK 50	5	AT5	105	63



Adaptor sleeves for MT with drawbar thread DIN 6364
 Douilles de réduction pour CM avec filetage DIN 6364



Verwendung:
 Zum Spannen von Werkzeugen mit Morsekegelschaft und Anzugsgewinde nach DIN 228-1 Form A.

Application:
 For clamping tools with Morse taper shank and thread according to DIN 228-1 form A.

Application:
 Pour le serrage d'outils avec queue cône Morse et filetage suivant DIN 228-1 forme A.

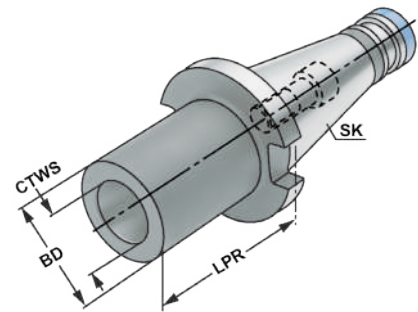

DIN 2080
Form A
≤ 5µm
G6.3 15.000 min⁻¹
DIN 6364
AT5



Bestell-Nr. Order no. Référence	SK	CTWS	THID	LPR	BD
401.08.01	SK 40	1	M6	50	25
401.08.02	SK 40	2	M10	50	32
401.08.03	SK 40	3	M12	65	40
401.08.04	SK 40	4	M16	95	48
401.08.04A*	SK 40	4	M16	110	63
501.08.01	SK 50	1	M6	60	25
501.08.02	SK 50	2	M10	60	32
501.08.03	SK 50	3	M12	65	40
501.08.04	SK 50	4	M16	65	48
501.08.04A*	SK 50	4	M16	80	63
501.08.05	SK 50	5	M20	120	63
501.08.05A*	SK 50	5	M20	138	78

- * Mit Mitnahmeausfräsung nach DIN 2201
- * With drive flats according to DIN 2201
- * Avec des fraises d'entraînement suivant DIN 2201

Lieferumfang: Mit eingebauter Fräseranzugsschraube
Delivery: With built-in tightening bolt
Livraison: Avec vis de serrage montée





Combi shell mill holders DIN 6358
Porte-fraises à double usage DIN 6358

**Verwendung:**

Zur Aufnahme von Walzen-, Walzenstirnfräsern oder Messerköpfen mit Längs- oder Quernut.

Application:

For mounting milling cutters with transverse or longitudinal groove.

Application:

Destiné à recevoir les porte-fraises, les fraises cylindriques ou les têtes de fraisage avec rainure longitudinale et transversale.

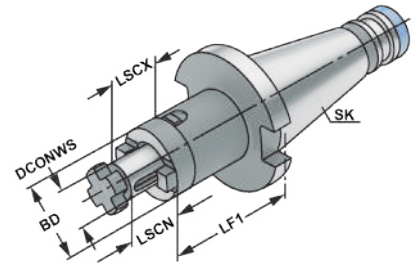

4

DIN 2080	Form AD	$\leq 5\mu\text{m}$	G6.3 15.000 min ⁻¹	DIN 6358	h6
----------	---------	---------------------	-------------------------------	----------	----

Bestell-Nr. Order no. Référence	SK	DCONWS	TDCON	LF1	LSCN	LSCX	BD
301.10.16	SK 30	16	h6	35	17	27	32
301.10.22	SK 30	22	h6	35	19	31	40
301.10.27	SK 30	27	h6	35	21	33	48
301.10.32	SK 30	32	h6	50	24	38	58
401.10.16	SK 40	16	h6	52	17	27	32
401.10.22	SK 40	22	h6	52	19	31	40
401.10.27	SK 40	27	h6	52	21	33	48
401.10.32	SK 40	32	h6	52	24	38	58
401.10.40	SK 40	40	h6	52	27	41	70
501.10.16	SK 50	16	h6	55	17	27	32
501.10.22	SK 50	22	h6	55	19	31	40
501.10.27	SK 50	27	h6	55	21	33	48
501.10.32	SK 50	32	h6	55	24	38	58
501.10.40	SK 50	40	h6	55	27	41	70

Lieferumfang: Mit Fräseranzugsschraube, Mitnehmerring und Passfeder
Delivery: With tightening bolt, driving ring and feather key
Livraison: Avec vis de serrage, bague d'entraînement et clavette

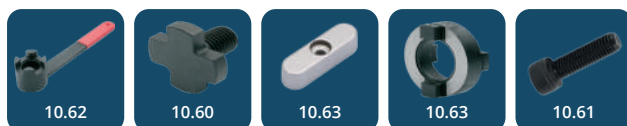

mit vergrößerter Anlagefläche

Shell mill holders DIN 6357 with enlarged contact face
 Porte-fraises à trou lisse DIN 6357 avec face de contact élargie



Verwendung:
 Zur Aufnahme von Walzen-, Walzenstirnfräsern oder Messerköpfen mit Längs- oder Quernut.

Application:
 For mounting milling cutters with transverse or longitudinal groove.

Application:
 Destiné à recevoir les porte-fraises, les fraises cylindriques ou les têtes de fraisage avec rainure longitudinale et transversale.

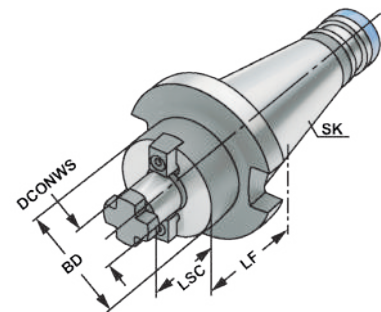

DIN 2080
Form AD
≤ 5µm
G6.3 15.000 min⁻¹
DIN 6357
h6



Bestell-Nr. Order no. Référence	SK	DCONWS	TDCON	LSC	LF	BD
401.11.16	SK 40	16	h6	17	30	38
401.11.22	SK 40	22	h6	19	30	48
401.11.27	SK 40	27	h6	21	30	58
401.11.32	SK 40	32	h6	24	30	78
401.11.40	SK 40	40	h6	27	30	88
501.11.22	SK 50	22	h6	19	35	48
501.11.27	SK 50	27	h6	21	35	58
501.11.32	SK 50	32	h6	24	40	78
501.11.40	SK 50	40	h6	27	33	88
501.11.60	SK 50	60	h6	40	55	129

DCONWS = 40 & 60 Für große Planfräser mit vier zusätzlichen Gewindebohrungen nach DIN 2079.
 For large diameter face mill cutters with four additional threaded holes according to DIN 2079.
 Pour fraises à surfacer à grands diamètres avec 4 taraudages supplémentaires suivant DIN 2079.

Lieferumfang: Mit Mitnehmersteinen, Kreuzschraube und Zylinderkopfschraube nach DIN 912 für Fräser mit innerer Kühlmittelzufuhr.
 Bei DCONWS = 60 nur mit vier Befestigungsschrauben nach DIN 912.

Delivery: With drivers, cross head retaining screw and cylinder head retaining screw for cutters with central coolant.
 For DCONWS = 60 only with four fixation screws according to DIN 912.

Livraison: Avec tenon d entraînement, vis cruciforme et vis à têtes cylindrique suivant DIN 912 pour les fraises avec arrosage central.
 Pour DCONWS = 60 est seulement avec quatre vis de fixation suivant DIN 912.





Drill chuck adaptors DIN 238
Arbres pour mandrins de perçage DIN 238



Verwendung:
Zur Aufnahme von Bohrfuttern.
Application:
For mounting drill chucks.
Application:
Pour le serrage de mandrins de perçage.

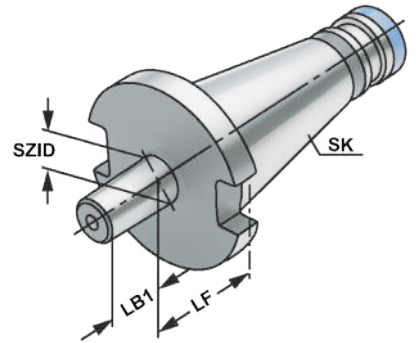

4

DIN 2080	Form A	≤ 5µm	G6,3 15.000 min ⁻¹	DIN 238	AT4
----------	--------	-------	-------------------------------	---------	-----

Bestell-Nr. Order no. Référence	SK	SZID	LF	LB1
301.14.12	SK 30	B12	15	18,5
301.14.16	SK 30	B16	17	24
401.14.12	SK 40	B12	15	18,5
401.14.16	SK 40	B16	17	24
401.14.18	SK 40	B18	17	32
501.14.16	SK 50	B16	20	24
501.14.18	SK 50	B18	20	32



CNC-Drill chucks for clockwise and counter clockwise rotation
Mandrins de perçage CNC pour rotation gauche-droite



Verwendung:
Zur Aufnahme von Werkzeugen mit Zylinderschaft.

Application:
For mounting tools with straight shanks.

Application:
Pour le serrage d'outils avec queue cylindrique.

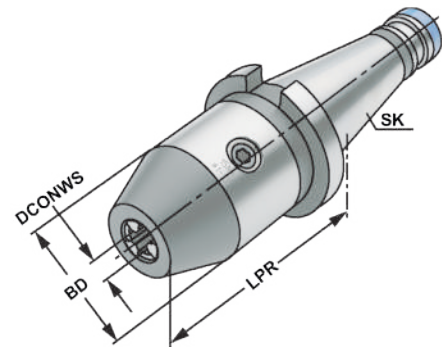

Bestell-Nr. Order no. Référence	SK	DCONWS Spannbereich Capacity Capacité	LPR	BD	DRVS
301.15.08	SK 30	0 - 8	60	36	4
301.15.13	SK 30	1,0 - 13	90	50	6
301.15.16	SK 30	2,5 - 16	95	50	6
401.15.08	SK 40	0 - 8	63	36	4
401.15.13	SK 40	1,0 - 13	83	50	6
401.15.16	SK 40	2,5 - 16	88	50	6
501.15.13	SK 50	1,0 - 13	85	50	6
501.15.16	SK 50	2,5 - 16	90	50	6

Hinweis: Hohe Präzision und Rundlaufgenauigkeit von $\leq 0,03$ mm. Sichere Spannung des Werkzeuges durch mechanische Spannkraftverstärkung. Kein selbständiges Lösen der Spannung während der Bearbeitung bei Links- oder Rechtslauf, sowie bei Spindelstop. Spannen und Lösen mit Sechskantschlüssel.

Note: High precision and accurate concentricity of ≤ 0.03 mm. Secure gripping of the tool through mechanical amplification of the clamping force. No automatic slackening of the clamping force while machining with either clockwise or counter clockwise rotation or on spindle stop. Clamping and releasing effected by means of an Allen wrench.

Observation: Précision élevée et exactitude de circularité de $\leq 0,03$ mm. Serrage sûr de l'outil grâce à l'amplification de la force de serrage. Pas de desserrage intempestif en cours d'usinage lors de la rotation la gauche ou la droite, de même qu'en cas d'arrêt de la broche. Serrage et desserrage en utilisant un clé sur à fourche.

Lieferumfang: Ohne Spannschlüssel
Delivery: Without wrench
Livraison: Sans clé de serrage



Adaptor sleeves for ISO-toolholders
 Douilles de réduction pour porte-outils ISO/SA



Verwendung:
 Zur Aufnahme von Steilkegeln nach DIN 69871, JIS B 6339 und DIN 2080.

Application:
 For holding tapers according to DIN 69871, JIS B 6339 and DIN 2080.

Application:
 Pour le serrage de porte-outils suivant DIN 69871, JIS B 6339 et DIN 2080.

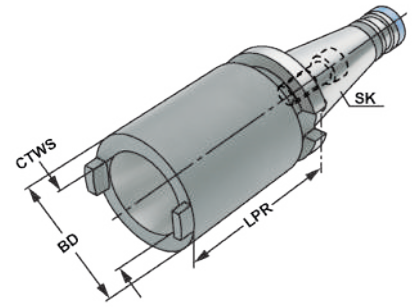

4

DIN 2080
Form A
≤ 5µm
G6,3 15.000 min⁻¹
AT5

Bestell-Nr. Order no. Référence	SK	CTWS	LPR	BD
401.09.30	SK 40	SK 30	50	50
401.09.40	SK 40	SK 40	100	63
501.09.40	SK 50	SK 40	50	70
501.09.50	SK 50	SK 50	125	97

Hinweis: Lieferung erfolgt mit eingebauter Schraube für Werkzeuge mit DIN 2080. Schraube für DIN 69871 Werkzeuge beiliegend.

Note: Delivered with a built-in screw for DIN 2080 tools. Additional screw for DIN 69871 tools included.

Observation: Livraison avec un vis incorporée pour outils DIN 2080. Vis pour cônes DIN 69871 incluse.



Boring bar blanks
Barres d'alésage



Verwendung:
Zur Herstellung von Sonderwerkzeugen.
Application:
For the manufacturing of special tools.
Application:
Pour la fabrication d'outils spéciaux.

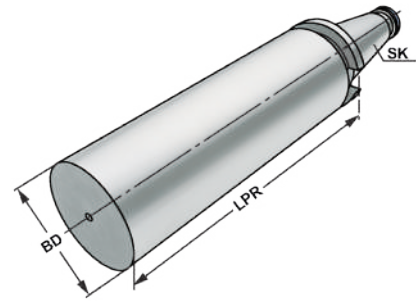

DIN
2080

Form
A

4

Bestell-Nr.
Order no.
Référence

SK

LPR

BD

401.17.63

SK 40

250

63

501.17.97

SK 50

315

97

Ausführung: Steilkegel und Bund gehärtet und geschliffen. Schaft weich zur weiteren Bearbeitung.
Version: *Cone and flange hardened and grinded. Soft body for later processing.*
Version: Cône et collerette durcis et rectifiés. Corps doux pour un usinage ultérieur.



auf Druck und Zug

Quick change tapping chucks with length compensation on compression and expansion

Mandrins de taraudage à changement rapide avec compensation longitudinale à la compression et traction



Verwendung:

Zur Aufnahme von Schnellwechsel-Einsätzen für Gewindebohrer.

Application:

For the chucking of quick change adaptors for taps.

Application:

Pour le serrage d'adaptateurs portetafonds à changement rapide.

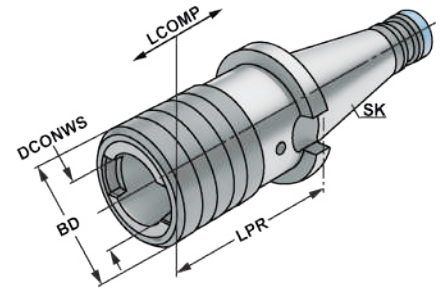

4



Bestell-Nr. Order no. Référence	SK	Spannbereich Capacity Capacité	Größe Size Taille	LPR	BD	DCONWS	LCOMP
301.16.12	SK 30	M3 - M14	1	55	38	19	7
301.16.20	SK 30	M5 - M22	2	86	54	31	12
401.16.12	SK 40	M3 - M14	1	55	38	19	7
401.16.20	SK 40	M5 - M22	2	86	54	31	12
401.16.36	SK 40	M14 - M36	3	132	78	48	17,5
501.16.12	SK 50	M3 - M14	1	62	38	19	7
501.16.20	SK 50	M5 - M22	2	90	54	31	12
501.16.36	SK 50	M14 - M36	3	117	78	48	17,5

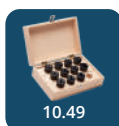

Test arbors
Mandrins de contrôle



Verwendung:
Zur Abnahme von Werkzeugmaschinen gemäß ISO-Empfehlung R230 oder zur Überprüfung der Werkzeugspindel.

Application:
For the inspection of machine tools according to ISO recommendation R230 or for testing the tool spindle.

Application:
Pour l'inspection de machine-outils suite à la recommandation ISO R230 ou pour la vérification de la broche.

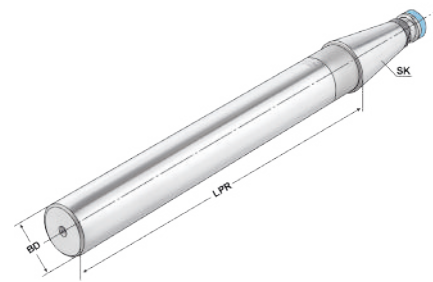

Bestell-Nr. Order no. Référence	SK	LPR	BD	Toleranz Tolerance Tolérance	max. Rundlaufabweichung max. concentricity deviation Faux-rond max.
401.18.40	SK 40	300	40	0,003	0,003
501.18.50	SK 50	300	50	0,003	0,003

Lieferumfang: Auslieferung mit Prüfprotokoll
Delivery: *Delivery with test certificate*
Livraison: Livraison avec rapport d'essais

Holzkasten für Kontrolldorne

Wooden box for test arbors
Coffret en bois pour mandrins de contrôle



Verwendung:
Zur Aufbewahrung von Kontrolldornen.

Application:
For the storage of test arbors.

Application:
Pour la conservation de mandrins de contrôle.



Bestell-Nr. Order no. Référence	Abmessung Size Dimension	für Kegelgrößen for cones pour cônes
701.18	460 × 130 × 115	SK 30 / 40 / 50

**WERKZEUGAUFNAHMEN
ISO 12164 & DIN 69893 (HSK)**

**TOOLHOLDERS
ISO 12164 & DIN 69893 (HSK)**

**PORTE-OUTILS
ISO 12164 & DIN 69893 (HSK)**

ISO 12164 - HSK

DIN 69893 - HSK

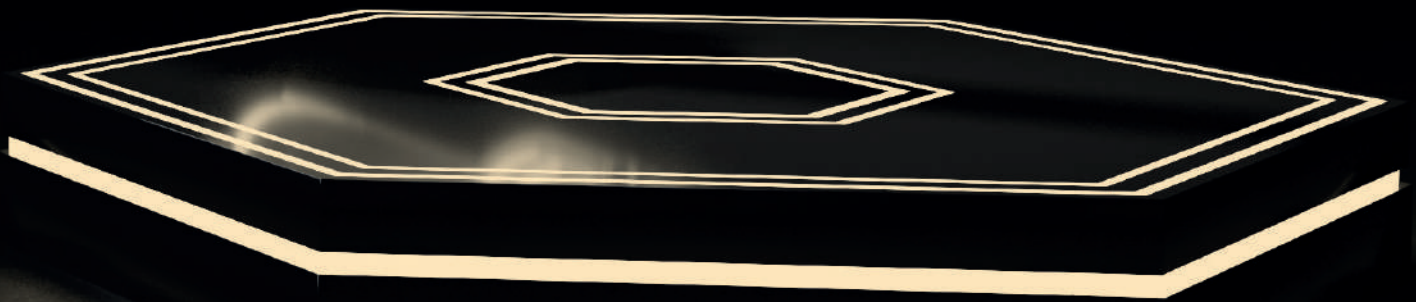
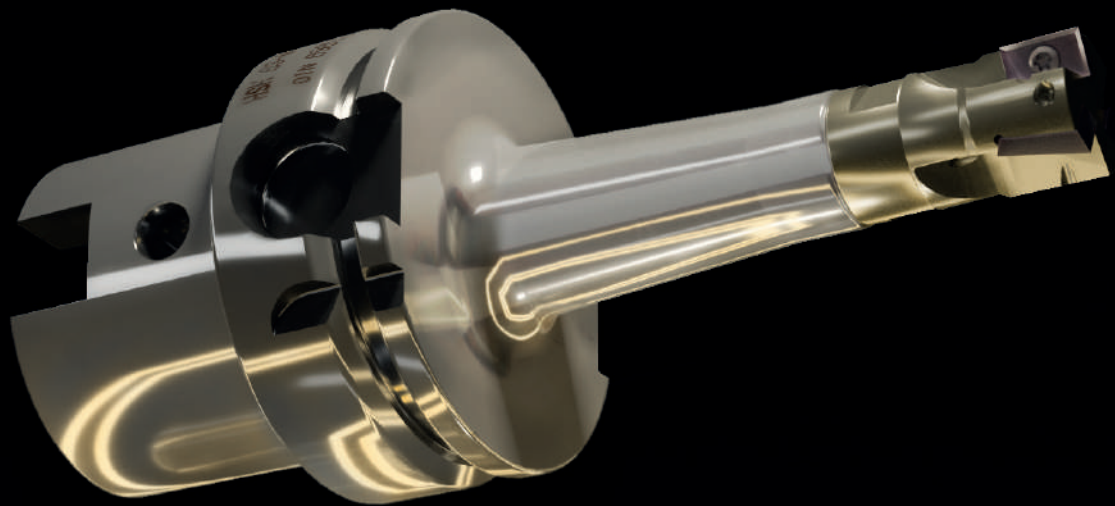

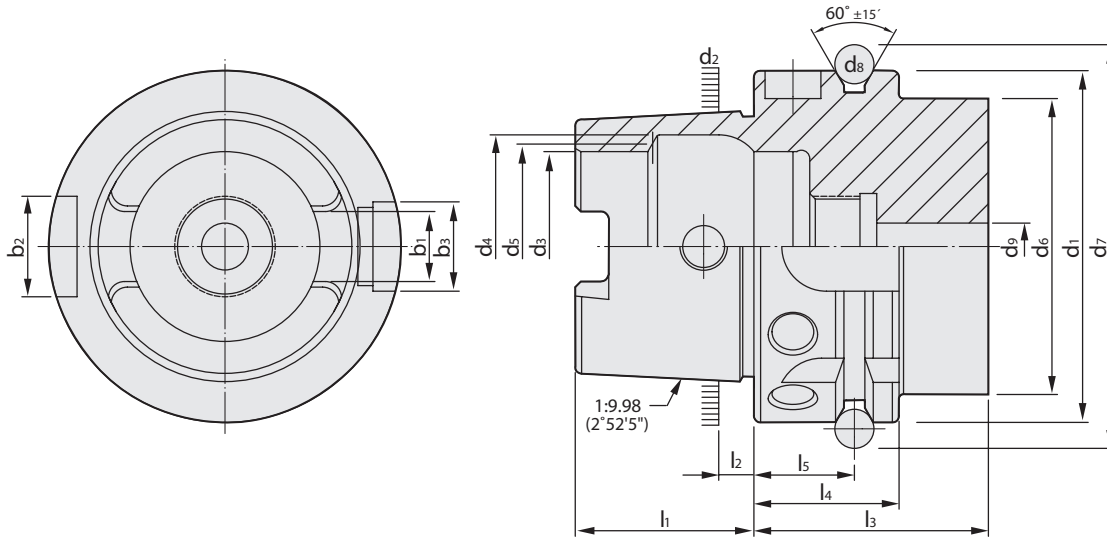

5

HSK	d ₁	d ₂	d ₃	d ₄	d ₅	d ₆	d ₇	d ₈	d ₉	l ₁	l ₂	l ₃	l ₄	l ₅	b ₁	b ₂	b ₃
	h10		H10	H11		max	⁰ _{-0,1}		max	⁰ _{-0,2}		min	⁰ _{-0,1}	±0,1	±0,04	H10	H10
25	25	19,006	14	16,4	15	20	28,5	3	3	13	2,5	20	10	4,5	6,05	6	7
32	32	24,007	17	20,5	19	26	37	4	4,2	16	3,2	35	20	16	7,05	7	9
40	40	30,007	21	25,5	23	34	45	4	5	20	4	35	20	16	8,05	9	11
50	50	38,009	26	32	29	42	59,3	7	6,8	25	5	42	26	18	10,54	12	14
63	63	48,010	34	40	37	53	72,3	7	8,4	32	6,3	42	26	18	12,54	16	18
80	80	60,012	42	50	46	68	88,8	7	10,2	40	8	42	26	18	16,04	18	20
100	100	75,013	53	63	58	88	109,75	7	12	50	10	45	29	20	20,02	20	22
125	125	95,016	67	80	73	111	134,75	7	14	63	12,5	45	29	20	25,02	25	28

Vorgewuchtet G 6,3 15.000 min-1
 Pre-balanced G 6,3 15.000 min-1
 Pré-équilibré G 6,3 15.000 min-1

G 2,5 Feinwuchten gegen Aufpreis
 G 2.5 Fine balancing at extra charge
 G 2,5 Equilibrage fin contre un supplément

Werkstoff: Legierter Einsatzstahl mit einer Zugfestigkeit im Kern von min. 950 N / mm². Einsatzgehärtet HRC 60 ± 2 (HV 700 ± 50), Härtetiefe 0,8 mm ± 0,2 mm, brüniert und präzisionsgeschliffen.

Material: Alloyed case-hardened steel, tensile core strength of min. 950 N / mm². Case hardened HRC 60 ± 2 (HV 700 ± 50), hardening depth 0.8 mm ± 0.2 mm, black-finished and precisely grinded.

Matière: Acier de cémentation allié. Résistance à la traction dans le noyau de min 950 N / mm². Cémentation à HRC 60 ± 2 (HV 700 ± 50), profondeur de cémentation 0,8 mm ± 0,2 mm, bruni et rectifié précisément.

Normative Verweise:

ISO 12164-1:2001-12
 Hohlkegelschnittstelle mit Plananlage
 - Teil 1: Schäfte; Maße

Normative references:

ISO 12164-1:2001
 Hollow taper interface with flange contact surface
 - Part 1: Shanks; Dimensions

Références normatives:

ISO 12164-1:2001
 Interfaces à cône creux-face
 - Partie 1: Queues; Dimensions

DIN 69893-1:2011
 Kegel-Hohlschäfte mit Plananlage besteht aus:
 - Teil 1: Kegel-Hohlschäfte Form A und Form C;
 Maße und Ausführung

DIN 69893-1:2011
 Hollow taper shanks with flange contact surface:
 - Part 1: Hollow taper shanks type A and type C;
 Dimensions and design

DIN 69893-1:2011
 Queues creuses coniques à surface de contact plane:
 - Partie 1: Queues creuses coniques type A et type C;
 Dimensions et conception



Index
Sommaire

5.05	5.06	5.07	5.09
			
5.10	5.11	5.13	5.16
			
5.19	5.20	5.21	5.23
			
5.24	5.25	5.26	5.27
			
5.28	5.29	5.30	5.31
			
5.32	5.33	5.37	5.44
			
5.46	5.47	5.48	5.49-5.50
			
5.51	5.67	5.83	
			
HSK-C	HSK-E	HSK-F	
			

5



Verwendung:
 Zur Aufnahme von Werkzeugen mit Zylinderschaft in Spannzangen.

Application:
 For mounting straight-shank tools in collets.

Application:
 Destiné à recevoir les outils avec les queues de forme cylindrique dans les pinces de serrage.

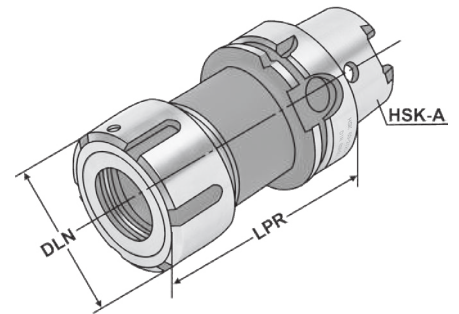

ISO 12164 Form A $\leq 3\mu\text{m}$ G7.5 25.000 min⁻¹ RFID Chip ISO 10897 13.04

5

Bestell-Nr. Order no. Référence	HSK	DCONWS Spannbereich Capacity Capacité	Typ	LPR	DLN	THID
A50.01.16	HSK-A 50	2 - 16	415E OZ 16	90	43	M16 x 2,0
A50.01.25	HSK-A 50	2 - 25	462E OZ 25	110	60	M16 x 2,0
A63.01.16	HSK-A 63	2 - 16	415E OZ 16	100	43	M16 x 2,0
A63.01.25	HSK-A 63	2 - 25	462E OZ 25	100	60	M16 x 2,0
A63.01.32	HSK-A 63	3 - 32	467E OZ 32	120	72	M16 x 2,0
A100.01.16	HSK-A 100	2 - 16	415E OZ 16	110	43	M16 x 2,0
A100.01.25	HSK-A 100	2 - 25	462E OZ 25	120	60	M16 x 2,0
A100.01.32	HSK-A 100	3 - 32	467E OZ 32	130	72	M16 x 2,0

Lieferumfang: Mit kugelgelagerter Spannmutter
Delivery: With ball bearing clamping nut
Livraison: Avec écrou de serrage à roulement à billes



**Verwendung:**

Zur Aufnahme von Werkzeugen mit Zylinderschaft in Spannzangen.
Für Anwendungen im HSC-Bereich und für hochpräzise Bearbeitungsergebnisse.

Application:

For mounting straight-shank tools in collets.
To use for high speed cutting and high precision milling.

Utilisation:

Pour la fixation d'outils à queue cylindrique dans les pinces de serrage. Pour l'UGV (Usinage à Grande Vitesse) et pour des résultats d'usinage de haute précision.

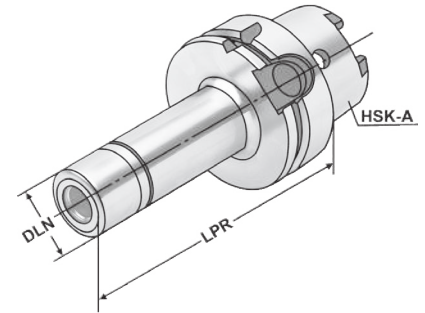

Bestell-Nr. Order no. Référence	HSK	DCONWS Spannbereich Capacity Capacité	Typ	LPR	DLN	THID
A40.03.10	HSK-A 40	1 - 10	490EK KPS 10	75	27,5	M12 x 1,75
A40.03.16	HSK-A 40	4 - 16	496EK KPS 16	80	40,0	M18 x 1,50
A50.03.10	HSK-A 50	1 - 10	490EK KPS 10	60	27,5	M12 x 1,75
A50.03.16	HSK-A 50	4 - 16	496EK KPS 16	80	40,0	M18 x 1,50
A63.03.10	HSK-A 63	1 - 10	490EK KPS 10	100	27,5	M12 x 1,75
A63.03.10.2	HSK-A 63	1 - 10	490EK KPS 10	160	27,5	M12 x 1,75
A63.03.16	HSK-A 63	4 - 16	496EK KPS 16	120	40,0	M18 x 1,50
A63.03.16.2	HSK-A 63	4 - 16	496EK KPS 16	160	40,0	M18 x 1,50

Lieferumfang: Mit gewuchteter Spannmutter
Delivery: With balanced clamping nut
Livraison: Avec écrou de serrage équilibré

Gewuchtete Ausführung**Balanced type
Type équilibré**

Bestell-Nr. Order no. Référence	Abmessung Size Dimension
---------------------------------------	--------------------------------

**Wuchten auf G 2,5 von vorgewuchteten
Kemmler-Werkzeugen**

Balancing at G 2.5 of pre-balanced Kemmler-tools
Équilibrage sur G 2,5 d'outils Kemmler pré-équilibrés

W25

Ohne Wuchtprotokoll

Without balancing report
Sans protocole d'équilibrage

W25.2

Mit Wuchtprotokoll

With balancing report
Avec protocole d'équilibrage

**Wuchten von nicht vorgewuchteten Werkzeugen
Balancing of unbalanced tools
Équilibrage d'outils non-équilibrés**

W25.1

Ohne Wuchtprotokoll

Without balancing report
Sans protocole d'équilibrage





Verwendung:
 Zur Aufnahme von Werkzeugen mit Zylinderschaft in Spannzangen.

Application:
 For mounting straight-shank tools in collets.

Application:
 Destiné à recevoir les outils avec les queues de forme cylindrique dans les pinces de serrage.

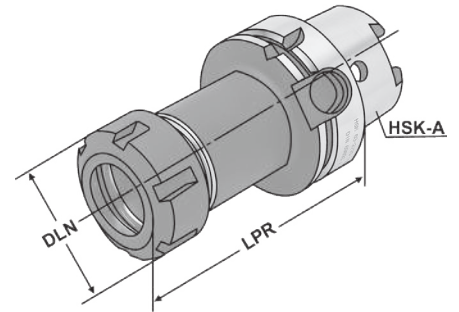

ISO 12164 Form A $\leq 3\mu\text{m}$ G2.5 25.000 min⁻¹ RFID Chip ISO 15488 13.04

5

Bestell-Nr. Order no. Référence	HSK	DCONWS Spannbereich Capacity Capacité	Typ	LPR	DLN	THID
A32.02.10	HSK-A 32	1 - 10	426E ER 16	80	32	M10 x 1,5
A32.02.20	HSK-A 32	2 - 20	470E ER 32	85	50	M16 x 2,0
A40.02.10	HSK-A 40	1 - 10	426E ER 16	80	32	M10 x 1,5
A40.02.16	HSK-A 40	2 - 16	430E ER 25	80	42	M16 x 2,0
A40.02.20	HSK-A 40	2 - 20	470E ER 32	80	50	M16 x 2,0
A50.02.10	HSK-A 50	1 - 10	426E ER 16	100	32	M10 x 1,5
A50.02.16	HSK-A 50	2 - 16	430E ER 25	80	42	M16 x 2,0
A50.02.20	HSK-A 50	2 - 20	470E ER 32	100	50	M16 x 2,0
A63.02.10.0	HSK-A 63	1 - 10	426E ER 16	75	32	-
A63.02.13.0	HSK-A 63	2 - 13	428E ER 20	75	35	-
A63.02.16.0	HSK-A 63	2 - 16	430E ER 25	75	42	-
A63.02.20.0	HSK-A 63	2 - 20	470E ER 32	75	50	-
A63.02.26.0	HSK-A 63	3 - 26	472E ER 40	85	63	-
A63.02.10	HSK-A 63	1 - 10	426E ER 16	100	32	M10 x 1,5
A63.02.13	HSK-A 63	2 - 13	428E ER 20	100	35	M12 x 1,75
A63.02.16	HSK-A 63	2 - 16	430E ER 25	100	42	M16 x 2,0
A63.02.20	HSK-A 63	2 - 20	470E ER 32	100	50	M16 x 2,0
A63.02.26	HSK-A 63	3 - 26	472E ER 40	120	63	M16 x 2,0

Lieferumfang: Mit gewuchteter Spannmutter
Delivery: With balanced clamping nut
Livraison: Avec écrou de serrage équilibré

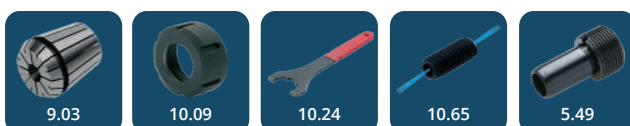

Collet chucks for collets ISO 15488 (DIN 6499) ER-system
Mandrins à pinces pour pinces ISO 15488 (DIN 6499) système ER

(DIN 69893-1 | HSK-A)



Verwendung:
Zur Aufnahme von Werkzeugen mit Zylinderschaft in Spannzangen.

Application:
For mounting straight-shank tools in collets.

Application:
Destiné à recevoir les outils avec les queues de forme cylindrique dans les pinces de serrage.

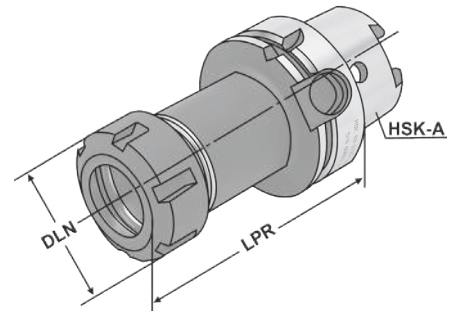

Bestell-Nr. Order no. Référence	HSK	DCONWS Spannbereich Capacity Capacité	Typ	LPR	DLN	THID
A63.02.10.130	HSK-A 63	1 - 10	426E ER 16	130	32	M10 x 1,5
A63.02.13.130	HSK-A 63	2 - 13	428E ER 20	130	35	M12 x 1,75
A63.02.16.130	HSK-A 63	2 - 16	430E ER 25	130	42	M16 x 2,0
A63.02.20.130	HSK-A 63	2 - 20	470E ER 32	130	50	M16 x 2,0
A63.02.26.130	HSK-A 63	3 - 26	472E ER 40	130	63	M16 x 2,0
A63.02.10.1	HSK-A 63	1 - 10	426E ER 16	160	32	M10 x 1,5
A63.02.13.1	HSK-A 63	2 - 13	428E ER 20	160	35	M12 x 1,75
A63.02.16.1	HSK-A 63	2 - 16	430E ER 25	160	42	M16 x 2,0
A63.02.20.1	HSK-A 63	2 - 20	470E ER 32	160	50	M16 x 2,0
A63.02.26.1	HSK-A 63	3 - 26	472E ER 40	160	63	M16 x 2,0
A63.02.10.3	HSK-A 63	1 - 10	426E ER 16	200	32	M10 x 1,5
A63.02.13.3	HSK-A 63	2 - 13	428E ER 20	200	35	M12 x 1,75
A63.02.16.3	HSK-A 63	2 - 16	430E ER 25	200	42	M16 x 2,0
A63.02.20.3	HSK-A 63	2 - 20	470E ER 32	200	50	M16 x 2,0
A63.02.26.3	HSK-A 63	3 - 26	472E ER 40	200	63	M16 x 2,0
A100.02.10	HSK-A 100	1 - 10	426E ER 16	100	32	M10 x 1,5
A100.02.16	HSK-A 100	2 - 16	430E ER 25	100	42	M16 x 2,0
A100.02.20	HSK-A 100	2 - 20	470E ER 32	100	50	M16 x 2,0
A100.02.26	HSK-A 100	3 - 26	472E ER 40	120	63	M16 x 2,0
A100.02.10.2	HSK-A 100	1 - 10	426E ER 16	160	32	M10 x 1,5
A100.02.16.2	HSK-A 100	2 - 16	430E ER 25	160	42	M16 x 2,0
A100.02.20.2	HSK-A 100	2 - 20	470E ER 32	160	50	M16 x 2,0
A100.02.26.2	HSK-A 100	3 - 26	472E ER 40	160	63	M16 x 2,0
A100.02.10.3	HSK-A 100	1 - 10	426E ER 16	200	32	M10 x 1,5
A100.02.16.3	HSK-A 100	2 - 16	430E ER 25	200	42	M16 x 2,0
A100.02.20.3	HSK-A 100	2 - 20	470E ER 32	200	50	M16 x 2,0
A100.02.26.3	HSK-A 100	3 - 26	472E ER 40	200	63	M16 x 2,0

Lieferumfang: Mit gewuchteter Spannmutter
Delivery: With balanced clamping nut
Livraison: Avec écrou de serrage équilibré

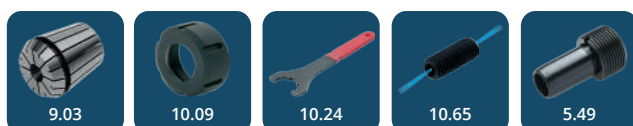

K Spannutter für Spannzangen ISO 15488 (DIN 6499) System ER - Mini ISO 12164 | HSK-A

Collet chucks for collets ISO 15488 (DIN 6499) ER-system - Mini
Mandrins à pinces pour pinces ISO 15488 (DIN 6499) système ER - Mini

(DIN 69893-1 | HSK-A)



Verwendung:
Zur Aufnahme von Werkzeugen mit Zylinderschaft in Spannzangen.

Application:
For mounting straight-shank tools in collets.

Application:
Destiné à recevoir les outils avec les queues de forme cylindrique dans les pinces de serrage.

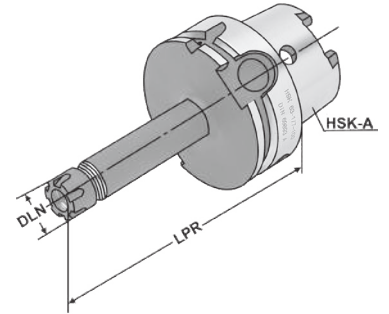

5

Bestell-Nr. Order no. Référence	HSK	DCONWS Spannbereich Capacity Capacité	Typ	LPR	DLN	THID
A32.02.07.M	HSK-A 32	1 - 7	4008E ER 11	50	16	M5
A32.02.10.M	HSK-A 32	1 - 10	426E ER 16	50	22	-
A32.02.16.M	HSK-A 32	2 - 16	430E ER 25	80	35	M8
A40.02.07.M	HSK-A 40	1 - 7	4008E ER 11	40	16	-
A40.02.10.M	HSK-A 40	1 - 10	426E ER 16	80	22	M8
A50.02.07.M	HSK-A 50	1 - 7	4008E ER 11	60	16	M6
A50.02.10.M	HSK-A 50	1 - 10	426E ER 16	60	22	-
A63.02.07.1	HSK-A 63	1 - 7	4008E ER 11	100	16	M8 x 1,25
A63.02.07.2	HSK-A 63	1 - 7	4008E ER 11	160	16	M8 x 1,25
A63.02.07.10.1	HSK-A 63	1 - 10	426E ER 16	100	22	7/16" 20 UNF
A63.02.07.10.2	HSK-A 63	1 - 10	426E ER 16	160	22	7/16" 20 UNF
A63.02.07.13.1	HSK-A 63	1 - 13	428E ER 20	100	28	9/16" 18 UNF
A63.02.07.13.2	HSK-A 63	1 - 13	428E ER 20	160	28	9/16" 18 UNF
A63.02.07.16.1	HSK-A 63	2 - 16	430E ER 25	100	35	11/16" 16 UN
A63.02.07.16.2	HSK-A 63	2 - 16	430E ER 25	160	35	11/16" 16 UN

Lieferumfang: Mit gewichteter Spannmutter
Delivery: With balanced clamping nut
Livraison: Avec écrou de serrage équilibré

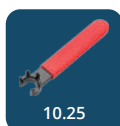



Precision collet chuck ER for collets ISO 15488 (DIN 6499) ER-system

Mandrin à pinces ER de précision pour pinces ISO 15488 (DIN 6499) système ER



Verwendung:
Zur Aufnahme von Werkzeugen mit Zylinderschaft in 3 µm-Spannzangen.

Application:
For mounting straight-shank tools in 3 µm-collets.

Application:
Pour le serrage d'outils avec queue cylindrique dans des pinces de serrage 3 µm.

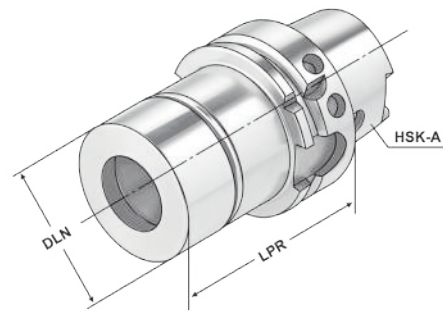

Bestell-Nr. Order no. Référence	HSK	DCONWS Spannbereich Capacity Capacité	Typ	LPR	LB	DLN	THID
A40.P2.20.070	HSK-A 40	2 - 20	470E ER 32	70	49,5	50	M16 x 2,0
A50.P2.20.080	HSK-A 50	2 - 20	470E ER 32	70	53	50	M16 x 2,0
A63.P2.20.080	HSK-A 63	2 - 20	470E ER 32	80	53	50	M16 x 2,0
A63.P2.20.100	HSK-A 63	2 - 20	470E ER 32	100	73	50	M16 x 2,0
A63.P2.20.125	HSK-A 63	2 - 20	470E ER 32	125	86	50	M16 x 2,0
A63.P2.20.150	HSK-A 63	2 - 20	470E ER 32	150	111	50	M16 x 2,0
A63.P2.20.200	HSK-A 63	2 - 20	470E ER 32	200	161	50	M16 x 2,0
A100.P2.20.100	HSK-A 100	2 - 20	470E ER 32	100	61	50	M16 x 2,0
A100.P2.20.125	HSK-A 100	2 - 20	470E ER 32	125	86	50	M16 x 2,0
A100.P2.20.150	HSK-A 100	2 - 20	470E ER 32	150	111	50	M16 x 2,0
A100.P2.20.200	HSK-A 100	2 - 20	470E ER 32	200	161	50	M16 x 2,0



Vorteile:

Exzellente Rundlaufgenauigkeit im System (Futter + Spannzange + Spannmutter)
 Extreme Haltekräfte (erhöht die Haltekraft um mindestens 60 % im Vergleich zu Standard ER-Futter)
 Glatte Spannmutter ohne Nuten für Hochgeschwindigkeitsbearbeitung

Advantages:

Excellent concentricity in the system (chuck + collet + clamping nut)
 Extremely strong holding force (increases the holding power by at least 60% compared to standard ER chuck)
 Plain clamping nut without grooves for high speed machining

Avantages:

Excellente précision de concentricité dans le système (mandrin + pince de serrage + écrou de serrage)
 La force de maintien extrême (augmente la force de maintien d'au moins à 60% par rapport aux mandrins standards ER)
 Ecrou de serrage lisse sans rainures pour l'usinage à haute vitesse

Hinweis:

Nur das Nennmaß DCONWS kann gespannt werden.

Note:

Only nominal size DCONWS can be clamped.

Observation:

Seulement la dimension nominale DCONWS peut être serrée.

Lieferumfang:

Inklusive Präzisions-Spannmutter

Delivery:

With precision clamping nut

Livraison:

Avec écrou de serrage de précision





Verwendung:
Zur Aufnahme von Werkzeugen mit Zylinderschaft nach DIN 1835 Form A+B+E und DIN 6535 Form HB+HE

Application:
For mounting straight-shank tools acc. DIN 1835 form A+B+E and DIN 6535 form HB+HE

Application:
Destiné à recevoir les outils avec les queues de forme cylindrique suivant DIN 1835 en forme A+B+E et DIN 6535 en forme HB+HE

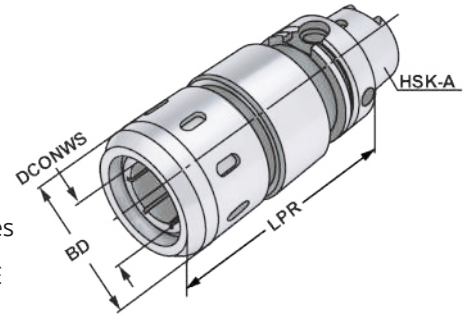

ISO
12164

Form
A

$\leq 3\mu\text{m}$

G6.3
 15.000
 min⁻¹

RFID
Chip

HKS

13.04

5

Bestell-Nr. Order no. Référence	HSK	DCONWS Spannbereich Capacity Capacité	Typ	DCONWS	LPR	BD
A63.64.20	HSK-A 63	3 - 20	HKS 20	20	95	53
A63.64.25	HSK-A 63	3 - 25	HKS 25	25	100	63
A63.64.32	HSK-A 63	3 - 32	HKS 32	32	110	68
A100.64.20	HSK-A 100	3 - 20	HKS 20	20	105	53
A100.64.25	HSK-A 100	3 - 25	HKS 25	25	105	63
A100.64.32	HSK-A 100	3 - 32	HKS 32	32	105	68

Größe Size Taille	20mm	25mm	32mm
Anzugsmoment Clamping torque Couple	50-70 Nm	80-100 Nm	80-100 Nm
Spannkraft Clamping force Tension	780 Nm	2000 Nm	2000 Nm

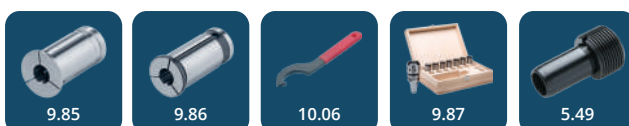

RELEASE THE BEAST





Verwendung:

Zum Spannen von zylindrischen Werkzeugschäften mit seitlicher Spannfläche nach DIN 1835 Form B (Weldon).

Application:

For mounting straight-shank tools with lateral flat according to DIN 1835 form B (Weldon).

Application:

Pour le serrage d'outils avec queue cylindrique et avec méplat de serrage latérale suivant DIN 1835 forme B (Weldon).

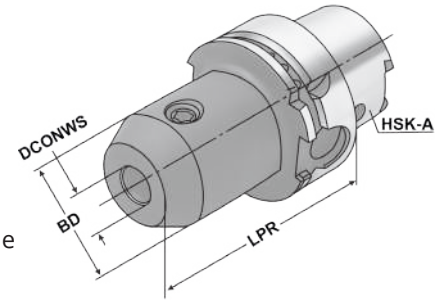

ISO 12164	Form A	$\leq 3\mu\text{m}$	G2.5 25.000 min ⁻¹	RFID Chip	DIN 1835-B	H4	13.04
-----------	--------	---------------------	-------------------------------------	-----------	------------	----	-------

5

Bestell-Nr. Order no. Référence	HSK	DCONWS	TDCON	LPR	BD
A32.04.06	HSK-A 32	6	H4	60	25
A32.04.08	HSK-A 32	8	H4	60	28
A32.04.10	HSK-A 32	10	H4	65	35
A32.04.12	HSK-A 32	12	H4	70	42
A32.04.14	HSK-A 32	14	H4	75	44
A32.04.16	HSK-A 32	16	H4	75	48
A32.04.20	HSK-A 32	20	H4	90	50
A40.04.06	HSK-A 40	6	H4	60	25
A40.04.08	HSK-A 40	8	H4	60	28
A40.04.10	HSK-A 40	10	H4	60	35
A40.04.12	HSK-A 40	12	H4	70	42
A40.04.14	HSK-A 40	14	H4	75	44
A40.04.16	HSK-A 40	16	H4	75	40
A40.04.18	HSK-A 40	18	H4	85	40
A40.04.20	HSK-A 40	20	H4	85	40
A40.04.25	HSK-A 40	25	H4	100	45
A40.04.32	HSK-A 40	32	H4	105	60
A50.04.06	HSK-A 50	6	H4	65	25
A50.04.08	HSK-A 50	8	H4	65	28
A50.04.10	HSK-A 50	10	H4	65	35
A50.04.12	HSK-A 50	12	H4	80	42
A50.04.14	HSK-A 50	14	H4	80	44
A50.04.16	HSK-A 50	16	H4	80	48
A50.04.18	HSK-A 50	18	H4	80	50
A50.04.20	HSK-A 50	20	H4	80	52
A50.04.25	HSK-A 50	25	H4	110	60
A50.04.32	HSK-A 50	32	H4	110	60

Hinweis: Ab DCONWS = 25 mit zwei Spannschrauben
Note: From DCONWS = 25 on two clamping screws
Observation: A partir de DCONWS = 25 avec deux vis de serrage

Lieferumfang: Mit Spannschraube
Delivery: With clamping screw
Livraison: Avec vis de serrage





End mill holders DIN 6359 for end mills DIN 1835-B

(DIN 69893-1 | HSK-A)

Porte-fraises DIN 6359 pour queues cylindriques DIN 1835-B

**Verwendung:**

Zum Spannen von zylindrischen Werkzeugschäften mit seitlicher Spannfläche nach DIN 1835 Form B (Weldon).

Application:

For mounting straight-shank tools with lateral flat according to DIN 1835 form B (Weldon).

Application:

Pour le serrage d'outils avec queue cylindrique et avec méplat de serrage latérale suivant DIN 1835 forme B (Weldon).

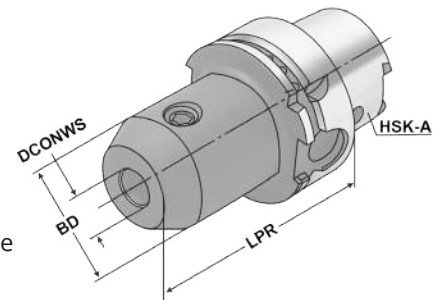

Bestell-Nr. Order no. Référence	HSK	DCONWS	TDCON	LPR	BD
A63.04.06	HSK-A 63	6	H4	65	25
A63.04.08	HSK-A 63	8	H4	65	28
A63.04.10	HSK-A 63	10	H4	65	35
A63.04.12	HSK-A 63	12	H4	80	42
A63.04.14	HSK-A 63	14	H4	80	44
A63.04.16	HSK-A 63	16	H4	80	48
A63.04.18	HSK-A 63	18	H4	80	50
A63.04.20	HSK-A 63	20	H4	80	52
A63.04.25	HSK-A 63	25	H4	110	65
A63.04.32	HSK-A 63	32	H4	110	72
A63.04.40	HSK-A 63	40	H4	125	80
A63.04.06.1	HSK-A 63	6	H4	100	25
A63.04.08.1	HSK-A 63	8	H4	100	28
A63.04.10.1	HSK-A 63	10	H4	100	35
A63.04.12.1	HSK-A 63	12	H4	100	35
A63.04.14.1	HSK-A 63	14	H4	100	44
A63.04.16.1	HSK-A 63	16	H4	100	48
A63.04.18.1	HSK-A 63	18	H4	100	50
A63.04.20.1	HSK-A 63	20	H4	100	52
A63.04.06.130	HSK-A 63	6	H4	130	25
A63.04.08.130	HSK-A 63	8	H4	130	28
A63.04.10.130	HSK-A 63	10	H4	130	35
A63.04.12.130	HSK-A 63	12	H4	130	35
A63.04.14.130	HSK-A 63	14	H4	130	44
A63.04.16.130	HSK-A 63	16	H4	130	48
A63.04.18.130	HSK-A 63	18	H4	130	50
A63.04.20.130	HSK-A 63	20	H4	130	52
A63.04.06.2	HSK-A 63	6	H4	160	25
A63.04.08.2	HSK-A 63	8	H4	160	28
A63.04.10.2	HSK-A 63	10	H4	160	35
A63.04.12.2	HSK-A 63	12	H4	160	35
A63.04.14.2	HSK-A 63	14	H4	160	44
A63.04.16.2	HSK-A 63	16	H4	160	48
A63.04.18.2	HSK-A 63	18	H4	160	50
A63.04.20.2	HSK-A 63	20	H4	160	52

**Verwendung:**

Zum Spannen von zylindrischen Werkzeugschäften mit seitlicher Spannfläche nach DIN 1835 Form B (Weldon).

Application:

For mounting straight-shank tools with lateral flat according to DIN 1835 form B (Weldon).

Application:

Pour le serrage d'outils avec queue cylindrique et avec méplat de serrage latérale suivant DIN 1835 forme B (Weldon).

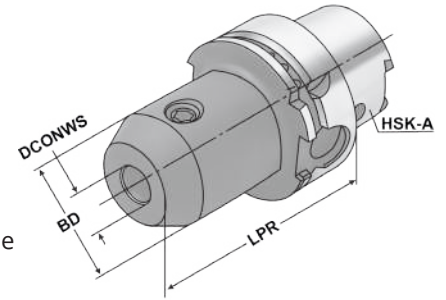

5

Bestell-Nr. Order no. Référence	HSK	DCONWS	TDCON	LPR	BD
A80.04.06	HSK-A 80	6	H4	80	25
A80.04.08	HSK-A 80	8	H4	80	28
A80.04.10	HSK-A 80	10	H4	80	35
A80.04.12	HSK-A 80	12	H4	80	42
A80.04.14	HSK-A 80	14	H4	80	44
A80.04.16	HSK-A 80	16	H4	100	48
A80.04.18	HSK-A 80	18	H4	100	50
A80.04.20	HSK-A 80	20	H4	100	52
A80.04.25	HSK-A 80	25	H4	100	65
A80.04.32	HSK-A 80	32	H4	110	72
A80.04.40	HSK-A 80	40	H4	120	80
A100.04.06	HSK-A 100	6	H4	80	25
A100.04.08	HSK-A 100	8	H4	80	28
A100.04.10	HSK-A 100	10	H4	80	35
A100.04.12	HSK-A 100	12	H4	80	42
A100.04.14	HSK-A 100	14	H4	80	44
A100.04.16	HSK-A 100	16	H4	100	48
A100.04.18	HSK-A 100	18	H4	100	50
A100.04.20	HSK-A 100	20	H4	100	52
A100.04.25	HSK-A 100	25	H4	100	65
A100.04.32	HSK-A 100	32	H4	100	72
A100.04.40	HSK-A 100	40	H4	105	80
A100.04.06.2	HSK-A 100	6	H4	160	25
A100.04.08.2	HSK-A 100	8	H4	160	28
A100.04.10.2	HSK-A 100	10	H4	160	35
A100.04.12.2	HSK-A 100	12	H4	160	35
A100.04.14.2	HSK-A 100	14	H4	160	44
A100.04.16.2	HSK-A 100	16	H4	160	48
A100.04.18.2	HSK-A 100	18	H4	160	50
A100.04.20.2	HSK-A 100	20	H4	160	52
A100.04.25.2	HSK-A 100	25	H4	160	65
A100.04.32.2	HSK-A 100	32	H4	160	72
A100.04.40.2	HSK-A 100	40	H4	160	80

Hinweis:**Note:****Observation:**

Ab DCONWS = 25 mit zwei Spannschrauben
From DCONWS = 25 on two clamping screws

A partir de DCONWS = 25 avec deux vis de serrage

Lieferumfang:**Delivery:****Livraison:**

Mit Spannschraube
With clamping screw

Avec vis de serrage



End mill holders DIN 6359 with coolant channels for end mills DIN 1835-B

Porte-fraises DIN 6359 avec canaux d'arrosage pour queues cylindriques DIN 1835-B

**Verwendung:**

Zum Spannen von zylindrischen Werkzeugschäften mit seitlicher Spannfläche nach DIN 1835 Form B (Weldon). Mit Kühlkanälen für optimale Kühlung der Werkzeugschneide.

Application:

For mounting straight-shank tools with lateral flat according to DIN 1835 form B (Weldon). With coolant channels for optimal coolant at the cutting edge.

Application:

Pour le serrage d'outils avec queue cylindrique et avec méplat de serrage latéral suivant DIN 1835 forme B (Weldon). Avec canaux d'arrosage pour refroidissement optimal des coupes.

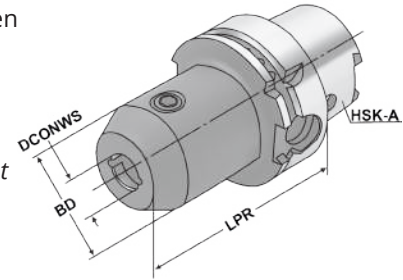

Bestell-Nr. Order no. Référence	HSK	DCONWS	TDCON	LPR	BD
A63.04.06.K	HSK-A 63	6	H4	65	25
A63.04.08.K	HSK-A 63	8	H4	65	28
A63.04.10.K	HSK-A 63	10	H4	65	35
A63.04.12.K	HSK-A 63	12	H4	80	42
A63.04.14.K	HSK-A 63	14	H4	80	44
A63.04.16.K	HSK-A 63	16	H4	80	48
A63.04.18.K	HSK-A 63	18	H4	80	50
A63.04.20.K	HSK-A 63	20	H4	80	52
A63.04.25.K	HSK-A 63	25	H4	110	65
A63.04.32.K	HSK-A 63	32	H4	110	72
A63.04.40.K	HSK-A 63	40	H4	125	80
A63.04.06.1.K	HSK-A 63	6	H4	100	25
A63.04.08.1.K	HSK-A 63	8	H4	100	28
A63.04.10.1.K	HSK-A 63	10	H4	100	35
A63.04.12.1.K	HSK-A 63	12	H4	100	42
A63.04.14.1.K	HSK-A 63	14	H4	100	44
A63.04.16.1.K	HSK-A 63	16	H4	100	48
A63.04.18.1.K	HSK-A 63	18	H4	100	50
A63.04.20.1.K	HSK-A 63	20	H4	100	52
A63.04.06.130.K	HSK-A 63	6	H4	130	25
A63.04.08.130.K	HSK-A 63	8	H4	130	28
A63.04.10.130.K	HSK-A 63	10	H4	130	35
A63.04.12.130.K	HSK-A 63	12	H4	130	35
A63.04.14.130.K	HSK-A 63	14	H4	130	44
A63.04.16.130.K	HSK-A 63	16	H4	130	48
A63.04.18.130.K	HSK-A 63	18	H4	130	50
A63.04.20.130.K	HSK-A 63	20	H4	130	52
A100.04.06.K	HSK-A 100	6	H4	80	25
A100.04.08.K	HSK-A 100	8	H4	80	28
A100.04.10.K	HSK-A 100	10	H4	80	35
A100.04.12.K	HSK-A 100	12	H4	80	42
A100.04.14.K	HSK-A 100	14	H4	80	44
A100.04.16.K	HSK-A 100	16	H4	100	48
A100.04.18.K	HSK-A 100	18	H4	100	50
A100.04.20.K	HSK-A 100	20	H4	100	52
A100.04.25.K	HSK-A 100	25	H4	100	65
A100.04.32.K	HSK-A 100	32	H4	100	72
A100.04.40.K	HSK-A 100	40	H4	105	80



End mill holders DIN 6359 for end mills DIN 1835-E
 Porte-fraises DIN 6359 pour queues cylindriques DIN 1835-E

(DIN 69893-1 | HSK-A)

**Verwendung:**

Zum Spannen von zylindrischen Werkzeugschäften mit geneigter Spannfläche nach DIN 1835 Form E (Whistle Notch).

Application:

For mounting straight-shank tools and inclined flat according to DIN 1835 form E (Whistle Notch).

Application:

Pour le serrage d'outils avec queue cylindrique et avec méplat incliné suivant DIN 1835 forme E (Whistle Notch).

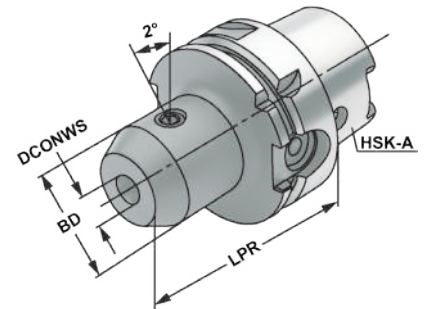

ISO 12164 Form A $\leq 3\mu\text{m}$ G2.5 25.000 min⁻¹ RFID Chip DIN 1835-E H4 13.04

5

Bestell-Nr. Order no. Référence	HSK	DCONWS	TDCON	LPR	BD
A32.05.06	HSK-A 32	6	H4	80	25
A32.05.08	HSK-A 32	8	H4	80	28
A32.05.10	HSK-A 32	10	H4	80	32
A32.05.12	HSK-A 32	12	H4	80	32
A32.05.14	HSK-A 32	14	H4	80	32
A32.05.16	HSK-A 32	16	H4	90	32
A32.05.18	HSK-A 32	18	H4	90	34
A32.05.20	HSK-A 32	20	H4	90	34
A40.05.06	HSK-A 40	6	H4	80	25
A40.05.08	HSK-A 40	8	H4	80	28
A40.05.10	HSK-A 40	10	H4	80	35
A40.05.12	HSK-A 40	12	H4	90	42
A40.05.14	HSK-A 40	14	H4	90	44
A40.05.16	HSK-A 40	16	H4	90	48
A40.05.18	HSK-A 40	18	H4	90	40
A40.05.20	HSK-A 40	20	H4	90	40
A40.05.25	HSK-A 40	25	H4	100	46
A40.05.32	HSK-A 40	32	H4	110	54
A50.05.06	HSK-A 50	6	H4	80	25
A50.05.08	HSK-A 50	8	H4	80	28
A50.05.10	HSK-A 50	10	H4	80	35
A50.05.12	HSK-A 50	12	H4	90	42
A50.05.14	HSK-A 50	14	H4	90	44
A50.05.16	HSK-A 50	16	H4	90	48
A50.05.18	HSK-A 50	18	H4	90	50
A50.05.20	HSK-A 50	20	H4	100	52
A50.05.25	HSK-A 50	25	H4	110	60
A50.05.32	HSK-A 50	32	H4	110	60

Hinweis: Ab DCONWS = 25 mit zwei Spannschrauben
Note: From DCONWS = 25 on two clamping screws
Observation: A partir de DCONWS = 25 avec deux vis de serrage

Lieferumfang: Mit Spannschraube und axialer Verstellerschraube
Delivery: With clamping screw and axial adjustment bolt
Livraison: Avec vis de serrage et vis de butée axiale





End mill holders DIN 6359 for end mills DIN 1835-E

(DIN 69893-1 | HSK-A)

Porte-fraises DIN 6359 pour queues cylindriques DIN 1835-E

**Verwendung:**

Zum Spannen von zylindrischen Werkzeugschäften mit geneigter Spannfläche nach DIN 1835 Form E (Whistle Notch).

Application:

For mounting straight-shank tools and inclined flat according to DIN 1835 form E (Whistle Notch).

Application:

Pour le serrage d'outils avec queue cylindrique et avec méplat incliné suivant DIN 1835 forme E (Whistle Notch).

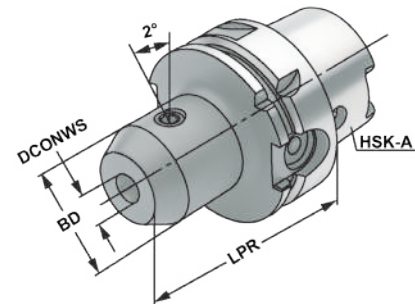

Bestell-Nr. Order no. Référence	HSK	DCONWS	TDCON	LPR	BD
A63.05.06	HSK-A 63	6	H4	80	25
A63.05.08	HSK-A 63	8	H4	80	28
A63.05.10	HSK-A 63	10	H4	80	35
A63.05.12	HSK-A 63	12	H4	90	42
A63.05.14	HSK-A 63	14	H4	90	44
A63.05.16	HSK-A 63	16	H4	100	48
A63.05.18	HSK-A 63	18	H4	100	50
A63.05.20	HSK-A 63	20	H4	100	52
A63.05.25	HSK-A 63	25	H4	110	65
A63.05.32	HSK-A 63	32	H4	110	72
A80.05.06	HSK-A 80	6	H4	90	25
A80.05.08	HSK-A 80	8	H4	90	28
A80.05.10	HSK-A 80	10	H4	90	35
A80.05.12	HSK-A 80	12	H4	100	42
A80.05.14	HSK-A 80	14	H4	100	44
A80.05.16	HSK-A 80	16	H4	100	48
A80.05.18	HSK-A 80	18	H4	100	50
A80.05.20	HSK-A 80	20	H4	110	52
A80.05.25	HSK-A 80	25	H4	110	65
A80.05.32	HSK-A 80	32	H4	120	72
A100.05.06	HSK-A 100	6	H4	90	25
A100.05.08	HSK-A 100	8	H4	90	28
A100.05.10	HSK-A 100	10	H4	90	35
A100.05.12	HSK-A 100	12	H4	100	42
A100.05.14	HSK-A 100	14	H4	100	44
A100.05.16	HSK-A 100	16	H4	100	48
A100.05.18	HSK-A 100	18	H4	100	50
A100.05.20	HSK-A 100	20	H4	110	52
A100.05.25	HSK-A 100	25	H4	120	65
A100.05.32	HSK-A 100	32	H4	120	72
A100.05.40	HSK-A 100	40	H4	120	80

Hinweis: Ab DCONWS = 25 mit zwei Spannschrauben
Note: From DCONWS = 25 on two clamping screws
Observation: A partir de DCONWS = 25 avec deux vis de serrage

Lieferumfang: Mit Spannschraube und axialer Verstellechraube
Delivery: With clamping screw and axial adjustment bolt
Livraison: Avec vis de serrage et vis de butée axiale





Milling arbors for screw-in cutters
Porte-fraises pour fraises à queue fileté

(DIN 69893-1 | HSK-A)



Verwendung:
Zur Aufnahme von Einschraubfräser mit Gewinde.
Application:
For mounting screw-in cutters with thread.
Application:
Pour le serrage de fraises à queue fileté.

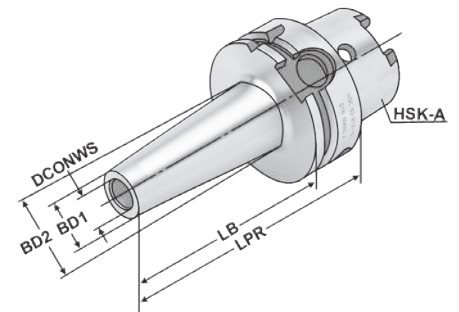

- ISO 12164
- Form A
- $\leq 3\mu\text{m}$
- G2.5 25.000 min⁻¹
- RFID Chip
- H7

5

Bestell-Nr. Order no. Référence	HSK	THSZWS	DCONWS	BD1	BD2	LPR	LB
A63.06.06	HSK-A 63	M6	6,5	10	13	51	25
A63.06.08	HSK-A 63	M8	8,5	13	15	51	25
A63.06.08.1	HSK-A 63	M8	8,5	13	23	76	50
A63.06.08.2	HSK-A 63	M8	8,5	13	23	101	75
A63.06.10	HSK-A 63	M10	10,5	18	20	51	25
A63.06.10.1	HSK-A 63	M10	10,5	18	23	76	50
A63.06.10.3	HSK-A 63	M10	10,5	18	32	126	100
A63.06.10.5	HSK-A 63	M10	10,5	18	37	176	150
A63.06.12	HSK-A 63	M12	12,5	21	24	51	25
A63.06.12.1	HSK-A 63	M12	12,5	21	24	76	50
A63.06.12.2	HSK-A 63	M12	12,5	21	31	101	75
A63.06.12.3	HSK-A 63	M12	12,5	21	33	126	100
A63.06.12.5	HSK-A 63	M12	12,5	21	40	176	150
A63.06.16	HSK-A 63	M16	17	29	29	51	25
A63.06.16.1	HSK-A 63	M16	17	29	34	76	50
A63.06.16.2	HSK-A 63	M16	17	29	34	101	75
A63.06.16.3	HSK-A 63	M16	17	29	36	126	100
A63.06.16.5	HSK-A 63	M16	17	29	43	176	150
A100.06.08.1	HSK-A 100	M8	8,5	13	23	79	50
A100.06.10.1	HSK-A 100	M10	10,5	18	23	79	50
A100.06.10.3	HSK-A 100	M10	10,5	18	32	129	100
A100.06.10.5	HSK-A 100	M10	10,5	18	37	179	150
A100.06.12.1	HSK-A 100	M12	12,5	21	24	79	50
A100.06.12.3	HSK-A 100	M12	12,5	21	33	129	100
A100.06.12.5	HSK-A 100	M12	12,5	21	40	179	150
A100.06.16.1	HSK-A 100	M16	17	29	34	79	50
A100.06.16.3	HSK-A 100	M16	17	29	36	129	100
A100.06.16.5	HSK-A 100	M16	17	29	43	179	150

**Empfohlenes Anzugsmoment
Recommended tightening torques
Torques de serrage recommandés**

M6	10 Nm
M8	25 Nm
M10	40 Nm
M12	60 Nm
M16	50 Nm





Combi shell mill holders DIN 6358
 Porte-fraises à double usage DIN 6358

(DIN 69893-1 | HSK-A)



Verwendung:
 Zur Aufnahme von Walzen-, Walzenstirnfräsern oder Messerköpfen mit Längs- oder Quernut.

Application:
 For mounting milling cutters with transverse or longitudinal groove.

Application:
 Destiné à recevoir les porte-fraises, les fraises cylindriques ou les têtes de fraisage avec rainure longitudinale et transversale.

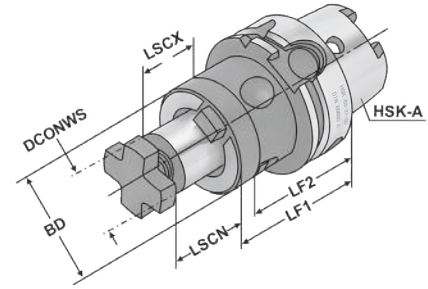

ISO 12164 Form A $\leq 5\mu\text{m}$ G6.3 15.000 min⁻¹ RFID Chip DIN 6358 h6

Bestell-Nr. Order no. Référence	HSK	DCONWS	TCDCON	LF1	LF2	LSCN	LSCX	BD
A32.10.16	HSK-A 32	16	h6	55	45	17	27	32
A32.10.22	HSK-A 32	22	h6	55	43	19	31	40
A32.10.27	HSK-A 32	27	h6	65	53	21	33	48
A32.10.32	HSK-A 32	32	h6	65	51	24	38	58
A32.10.40	HSK-A 32	40	h6	65	51	27	41	70
A40.10.16	HSK-A 40	16	h6	50	40	17	27	32
A40.10.22	HSK-A 40	22	h6	50	38	19	31	40
A40.10.27	HSK-A 40	27	h6	65	53	21	33	48
A40.10.32	HSK-A 40	32	h6	65	51	24	38	58
A50.10.16	HSK-A 50	16	h6	50	40	17	27	32
A50.10.22	HSK-A 50	22	h6	50	38	19	31	40
A50.10.27	HSK-A 50	27	h6	65	53	21	33	48
A50.10.32	HSK-A 50	32	h6	65	51	24	38	58
A63.10.16	HSK-A 63	16	h6	60	50	17	27	32
A63.10.22	HSK-A 63	22	h6	60	48	19	31	40
A63.10.27	HSK-A 63	27	h6	60	48	21	33	48
A63.10.32	HSK-A 63	32	h6	60	46	24	38	58
A63.10.40	HSK-A 63	40	h6	70	56	27	41	70
A63.10.16.1	HSK-A 63	16	h6	100	90	17	27	32
A63.10.22.1	HSK-A 63	22	h6	100	88	19	31	40
A63.10.27.1	HSK-A 63	27	h6	100	88	21	33	48
A63.10.32.1	HSK-A 63	32	h6	100	86	24	38	58
A80.10.16	HSK-A 80	16	h6	60	50	17	27	32
A80.10.22	HSK-A 80	22	h6	60	48	19	31	40
A80.10.27	HSK-A 80	27	h6	60	48	21	33	48
A80.10.32	HSK-A 80	32	h6	60	46	24	38	58
A80.10.40	HSK-A 80	40	h6	70	56	27	41	70
A100.10.16	HSK-A 100	16	h6	60	50	17	27	32
A100.10.22	HSK-A 100	22	h6	60	48	19	31	40
A100.10.27	HSK-A 100	27	h6	60	48	21	33	48
A100.10.32	HSK-A 100	32	h6	60	46	24	38	58
A100.10.40	HSK-A 100	40	h6	70	56	27	41	70

Lieferumfang: Mit Fräseranzugsschraube, Mitnehmerring und Passfeder
Delivery: With tightening bolt, driving ring and feather key
Livraison: Avec vis de serrage, bague d'entraînement et clavette



Shell mill holders DIN 6357 with enlarged contact face and coolant exit bores on the end face
 Porte-fraises à trou lisse DIN 6357 avec surface de contact agrandie et arrosage frontal



Verwendung:
 Zur Aufnahme von Messerköpfen und Fräsern mit Quernut.

Application:
 For mounting milling cutters with transversal groove.

Application:
 Destiné à recevoir les fraises et les fraises avec des rainures transversales.

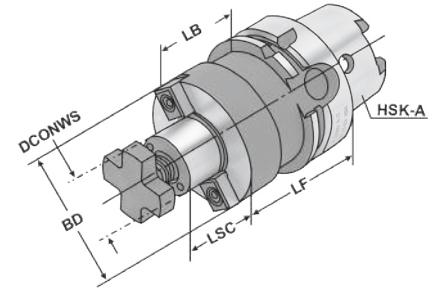

5

Bestell-Nr. Order no. Référence	HSK	DCONWS	TCDCON	LF	LSC	LB	BD
A40.11.16	HSK-A 40	16	h6	50	17	30	40
A40.11.22	HSK-A 40	22	h6	50	19	30	48
A40.11.27	HSK-A 40	27	h6	55	21	35	60
A40.11.32	HSK-A 40	32	h6	60	24	40	78
A50.11.16	HSK-A 50	16	h6	50	17	24	40
A50.11.22	HSK-A 50	22	h6	60	19	34	48
A50.11.27	HSK-A 50	27	h6	60	21	34	60
A50.11.32	HSK-A 50	32	h6	60	24	34	78
A63.11.16	HSK-A 63	16	h6	50	17	24	38
A63.11.22	HSK-A 63	22	h6	50	19	24	48
A63.11.27	HSK-A 63	27	h6	60	21	34	58
A63.11.32	HSK-A 63	32	h6	60	24	34	78
A63.11.40	HSK-A 63	40	h6	60	27	34	88
A63.11.16.1	HSK-A 63	16	h6	100	17	74	38
A63.11.22.1	HSK-A 63	22	h6	100	19	74	48
A63.11.27.1	HSK-A 63	27	h6	100	21	74	58
A63.11.32.1	HSK-A 63	32	h6	100	24	74	78
A63.11.40.1	HSK-A 63	40	h6	100	27	74	88
A63.11.16.2	HSK-A 63	16	h6	160	17	134	38
A63.11.22.2	HSK-A 63	22	h6	160	19	134	48
A63.11.27.2	HSK-A 63	27	h6	160	21	134	58
A63.11.32.2	HSK-A 63	32	h6	160	24	134	78
A63.11.40.2	HSK-A 63	40	h6	160	27	134	88

DCONWS = 40

Für große Planfräser mit vier zusätzlichen Gewindebohrungen nach DIN 2079.
 For large diameter face mill cutters with four additional threaded holes according to DIN 2079.
 Pour fraises à surfacer à grands diamètres avec 4 taraudages supplémentaires suivant DIN 2079.

Lieferumfang: Mit Mitnehmersteinen, Kreuzschraube und Zylinderkopfschraube nach DIN 912 für Fräser mit innerer Kühlmittelzufuhr.

Delivery: With drivers, cross head retaining screw and cylinder head retaining screw for cutters with central coolant.

Livraison: Avec tenon d entraînement, vis cruciforme et vis à têtes cylindrique suivant DIN 912 pour les fraises avec arrosage central.

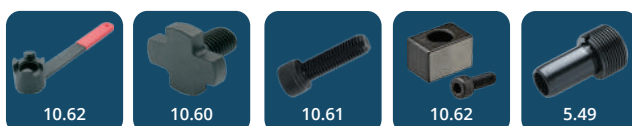



Shell mill holders DIN 6357 with enlarged contact face and coolant exit bores on the end face
 Porte-fraises à trou lisse DIN 6357 avec surface de contact agrandie et arrosage frontal



Verwendung:
 Zur Aufnahme von Messerköpfen und Fräsern mit Quernut.

Application:
 For mounting milling cutters with transversal groove.

Application:
 Destiné à recevoir les fraises et les fraises avec des rainures transversales.

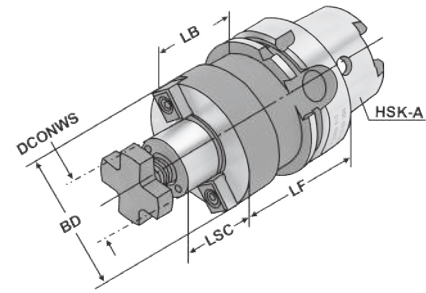

Bestell-Nr. Order no. Référence	HSK	DCONWS	TCDCON	LF	LSC	LB	BD
A80.11.22	HSK-A 80	22	h6	50	19	24	48
A80.11.27	HSK-A 80	27	h6	50	21	24	58
A80.11.32	HSK-A 80	32	h6	60	24	34	78
A80.11.40	HSK-A 80	40	h6	60	27	34	88
A100.11.16	HSK-A 100	16	h6	50	17	21	38
A100.11.22	HSK-A 100	22	h6	50	19	21	48
A100.11.27	HSK-A 100	27	h6	50	21	21	58
A100.11.32	HSK-A 100	32	h6	50	24	21	78
A100.11.40	HSK-A 100	40	h6	70	27	41	88
A100.11.60	HSK-A 100	60	h6	70	40	41	130
A100.11.16.1	HSK-A 100	16	h6	100	17	71	38
A100.11.22.1	HSK-A 100	22	h6	100	19	71	48
A100.11.27.1	HSK-A 100	27	h6	100	21	71	58
A100.11.32.1	HSK-A 100	32	h6	100	24	71	78
A100.11.40.1	HSK-A 100	40	h6	100	27	71	88
A100.11.16.2	HSK-A 100	16	h6	160	17	131	38
A100.11.22.2	HSK-A 100	22	h6	160	19	131	48
A100.11.27.2	HSK-A 100	27	h6	160	21	131	58
A100.11.32.2	HSK-A 100	32	h6	160	24	131	78
A100.11.40.2	HSK-A 100	40	h6	160	27	131	88

5

DCONWS = 40 & 60 Für große Planfräser mit vier zusätzlichen Gewindebohrungen nach DIN 2079.
 For large diameter face mill cutters with four additional threaded holes according to DIN 2079.
 Pour fraises à surfacer à grands diamètres avec 4 taraudages supplémentaires suivant DIN 2079.

Lieferumfang: Mit Mitnehmersteinen, Kreuzschraube und Zylinderkopfschraube nach DIN 912 für Fräser mit innerer Kühlmittelzufuhr.
 Bei DCONWS = 60 nur mit vier Befestigungsschrauben nach DIN 912.

Delivery: With drivers, cross head retaining screw and cylinder head retaining screw for cutters with central coolant.
 For DCONWS = 60 only with four fixation screws according to DIN 912.

Livraison: Avec tenon d entraînement, vis cruciforme et vis à têtes cylindrique suivant DIN 912 pour les fraises avec arrosage central.
 Pour DCONWS = 60 est seulement avec quatre vis de fixation suivant DIN 912.

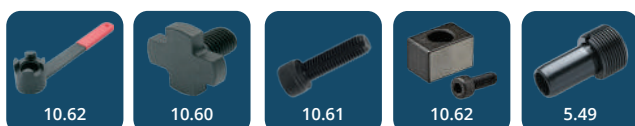

**Verwendung:**

Zur Aufnahme von Werkzeugen mit Morsekegelschaft und Austreibblappen nach DIN 228-1 Form B.

Application:

For mounting tools with Morse taper shank and tang according to DIN 228-1 form B.

Application:

Pour le serrage d'outils avec queue cône Morse et tenon suivant DIN 228-1 forme B.

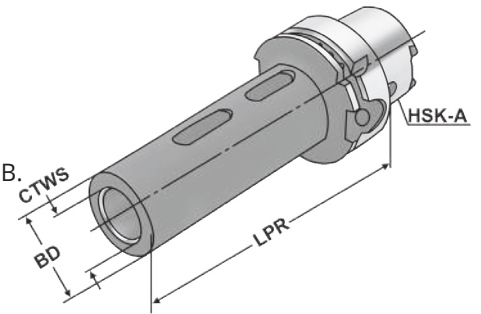

ISO 12164	Form A	≤ 5µm	G6.3 15.000 min ⁻¹	RFID Chip	DIN 6383	AT5
-----------	--------	-------	-------------------------------	-----------	----------	-----

5

Bestell-Nr. Order no. Référence	HSK	CTWS	TDCON	LPR	BD
A50.07.01	HSK-A 50	1	AT5	100	25
A50.07.02	HSK-A 50	2	AT5	120	32
A50.07.03	HSK-A 50	3	AT5	140	40
A63.07.01	HSK-A 63	1	AT5	100	25
A63.07.02	HSK-A 63	2	AT5	120	32
A63.07.03	HSK-A 63	3	AT5	140	40
A63.07.04	HSK-A 63	4	AT5	160	48
A80.07.01	HSK-A 80	1	AT5	110	25
A80.07.02	HSK-A 80	2	AT5	120	32
A80.07.03	HSK-A 80	3	AT5	140	40
A80.07.04	HSK-A 80	4	AT5	160	48
A100.07.01	HSK-A 100	1	AT5	110	25
A100.07.02	HSK-A 100	2	AT5	120	32
A100.07.03	HSK-A 100	3	AT5	150	40
A100.07.04	HSK-A 100	4	AT5	170	48
A100.07.05	HSK-A 100	5	AT5	200	63





Adaptor sleeves for MT with drawbar thread DIN 6364
 Douilles de réduction pour CM avec filetage DIN 6364

(DIN 69893-1 | HSK-A)



Verwendung:
 Zum Spannen von Werkzeugen mit Morsekegelschaft und Anzugsgewinde nach DIN 228-1 Form A.

Application:
 For clamping tools with Morse taper shank and thread according to DIN 228-1 form A.

Application:
 Pour le serrage d'outils avec queue cône Morse et filetage suivant DIN 228-1 forme A.

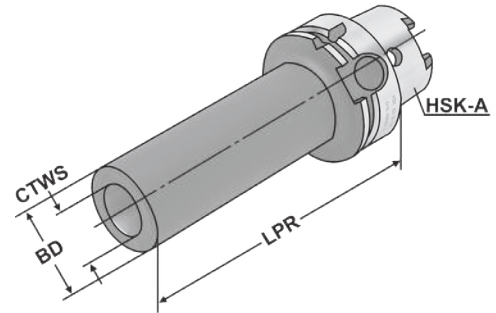

ISO 12164 Form A $\leq 5\mu\text{m}$ G6.3 15.000 min⁻¹ RFID Chip DIN 6364 AT5

Bestell-Nr. Order no. Référence	HSK	CTWS	THID	LPR	BD
A50.08.01	HSK-A 50	1	M6	100	25
A50.08.02	HSK-A 50	2	M10	120	32
A50.08.03	HSK-A 50	3	M12	140	40
A63.08.01	HSK-A 63	1	M6	100	25
A63.08.02	HSK-A 63	2	M10	120	32
A63.08.03	HSK-A 63	3	M12	140	40
A63.08.04	HSK-A 63	4	M16	160	48
A80.08.01	HSK-A 80	1	M6	110	25
A80.08.02	HSK-A 80	2	M10	120	32
A80.08.03	HSK-A 80	3	M12	150	40
A80.08.04	HSK-A 80	4	M16	170	48
A100.08.01	HSK-A 100	1	M6	110	25
A100.08.02	HSK-A 100	2	M10	120	32
A100.08.03	HSK-A 100	3	M12	150	40
A100.08.04	HSK-A 100	4	M16	170	48
A100.08.05	HSK-A 100	5	M20	200	63

5

Lieferumfang: Mit eingebauter Fräseranzugsschraube
Delivery: With built-in tightening bolt
Livraison: Avec vis de serrage montée



Quick change tapping chucks **with** length compensation on compression and expansion
 Mandrins de taraudage à changement rapide **avec** compensation longitudinale à la compression et traction



Verwendung:
 Zur Aufnahme von Schnellwechsel-Ein-
 sätzen für Gewindebohrer.
Application:
 For the chucking of quick change adaptors
 for taps.
Application:
 Pour le serrage d'adaptateurs porte-
 tarauds à changement rapide.

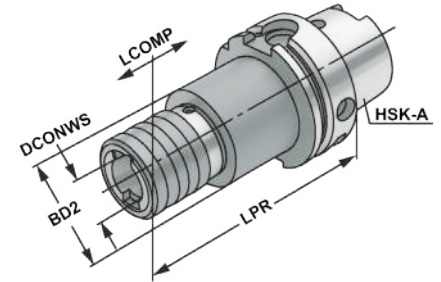

ISO 12164 Form A RFID Chip 13.04

5

Bestell-Nr. Order no. Référence	HSK	Spannbereich Capacity Capacité	SZID	DCONWS	LPR	BD2	LCOMP
A32.16.12	HSK-A 32	M3 - M14	1	19	80	41	7
A40.16.12	HSK-A 40	M3 - M14	1	19	95	36	7
A50.16.12	HSK-A 50	M3 - M14	1	19	100	36	7
A50.16.20	HSK-A 50	M5 - M22	2	31	140	53	12
A63.16.12	HSK-A 63	M3 - M14	1	19	102	50	7
A63.16.20	HSK-A 63	M5 - M22	2	31	140	54	12
A63.16.36	HSK-A 63	M14 - M36	3	48	210	86	17,5
A80.16.12	HSK-A 80	M3 - M14	1	19	72	41	7
A80.16.20	HSK-A 80	M5 - M22	2	31	108	60	10
A80.16.36	HSK-A 80	M14 - M36	3	48	141	86	17,5
A100.16.12	HSK-A 100	M3 - M14	1	19	112	38	7
A100.16.20	HSK-A 100	M5 - M22	2	31	148	54	12
A100.16.36	HSK-A 100	M14 - M36	3	48	210	86	17,5

Hinweis: Für Bearbeitungszentren ohne Synchronspindel.
Note: For machining centres without synchronous spindle.
Observation: Pour centres d'usinage sans broche synchrone.





Quick change tapping chucks without length compensation on compression and expansion

Mandrins de taraudage à changement rapide sans compensation longitudinale à la compression et traction



Verwendung:

Zur Aufnahme von Schnellwechsel-Ein-sätzen für Gewindebohrer.

Application:

For the chucking of quick change adaptors for taps.

Application:

Pour le serrage d'adapteurs porte-tarauts à changement rapide.

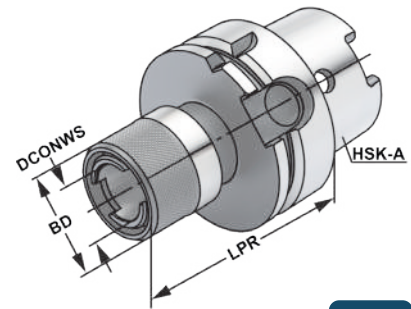

ISO 12164 Form A RFID Chip

13.04

Bestell-Nr. Order no. Référence	HSK	Spannbereich Capacity Capacité	SZID	DCONWS	LPR	BD
A50.16.12.1	HSK-A 50	M3 – M14	1	19	65	38
A50.16.20.1	HSK-A 50	M5 – M22	2	31	100	54
A63.16.12.1	HSK-A 63	M3 – M14	1	19	65	38
A63.16.20.1	HSK-A 63	M5 – M22	2	31	100	54
A100.16.12.1	HSK-A 100	M3 – M14	1	19	80	38
A100.16.20.1	HSK-A 100	M5 – M22	2	31	90	54
A100.16.36.1	HSK-A 100	M14 – M36	3	48	130	86



Hinweis: Für Bearbeitungszentren mit Synchronspindel.
Note: For machining centres with synchronous spindle.
Observation: Pour centres d'usinage avec broche synchrone.





Tapping chucks for synchronisation for collets ISO 15488 (DIN 6499) ER-system

Mandrins de taraudage pour synchronisation pour pinces ISO 15488 (DIN 6499) système ER



Verwendung:
Für Bearbeitungszentren mit Synchronspindel.

Application:
For machining centres with synchronous spindle.

Application:
Pour centres d'usinage avec broche synchrone.

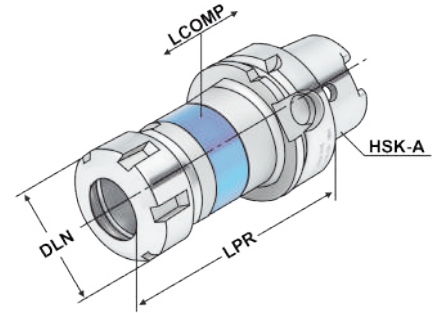

ISO 12164 | Form A | ≤ 60µm | G6.3 15.000 min⁻¹ | RFID Chip | ISO 15488 | 13.04

5

Bestell-Nr. Order no. Référence	HSK	DCONWS Spannbereich Capacity Capacité	Typ	LPR	DLN	LCOMP
A40.16.02.10	HSK-A 40	M3 – M12	426E ER 16	87	28	0,5
A40.16.02.13	HSK-A 40	M3 – M16	428E ER 20	93	34	0,5
A50.16.02.10	HSK-A 50	M3 – M12	426E ER 16	87	28	0,5
A50.16.02.13	HSK-A 50	M3 – M16	428E ER 20	88	34	0,5
A50.16.02.16	HSK-A 50	M3 – M20	430E ER 25	92	42	0,5
A50.16.02.20	HSK-A 50	M3 – M27	470E ER 32	116	50	0,5
A63.16.02.10 ¹	HSK-A 63	M3 – M12	426E ER 16 SW25	93	28	0,5
A63.16.02.10.M ²	HSK-A 63	M3 – M12	426E ER 16 Mini	93	22	0,5
A63.16.02.10.1.M ²	HSK-A 63	M3 – M12	426E ER 16 Mini	100	22	0,5
A63.16.02.13	HSK-A 63	M3 – M16	428E ER 20	94	34	0,5
A63.16.02.16	HSK-A 63	M3 – M20	430E ER 25	98	42	0,5
A63.16.02.20	HSK-A 63	M3 – M27	470E ER 32	108	50	0,5
A63.16.02.26	HSK-A 63	M3 – M33	472E ER 40	133,5	63	0,5
A80.16.02.13	HSK-A 80	M3 – M16	428E ER 20	100	34	0,5
A80.16.02.16	HSK-A 80	M3 – M20	430E ER 25	105	42	0,5
A80.16.02.20	HSK-A 80	M3 – M27	470E ER 32	110,5	50	0,5
A80.16.02.26	HSK-A 80	M3 – M33	472E ER 40	131	63	0,5
A100.16.02.10 ¹	HSK-A 100	M3 – M12	426E ER 16 SW25	96	28	0,5
A100.16.02.10.1.M ²	HSK-A 100	M3 – M12	426E ER 16 Mini	106	22	0,5
A100.16.02.13	HSK-A 100	M3 – M16	428E ER 20	97	34	0,5
A100.16.02.16	HSK-A 100	M3 – M20	430E ER 25	101	42	0,5
A100.16.02.20	HSK-A 100	M3 – M27	470E ER 32	110	50	0,5
A100.16.02.26	HSK-A 100	M3 – M33	472E ER 40	133	63	0,5

¹ Sechskantmutter
¹ Hexagonal clamping nut
¹ Écrous hexagonal

² Minimutter
² Mini nut
² Écrous mini

Lieferumfang: Mit gewuchteter Spannmutter
Delivery: With balanced clamping nut
Livraison: Avec écrou de serrage équilibré





Boring holders for drills with indexable inserts form E1
Portes forets pour forets à plaquettes réversibles forme E1

(DIN 69893-1 | HSK-A)



Verwendung:
Zur Aufnahme von allen nach DIN 6595 genormten Vollbohrern mit Zylinder-schaft.

Application:
For all solid drills with cylindrical shank according to DIN 6595.

Application:
Pour le serrage de forets à queue cylindrique suivant DIN 6595.

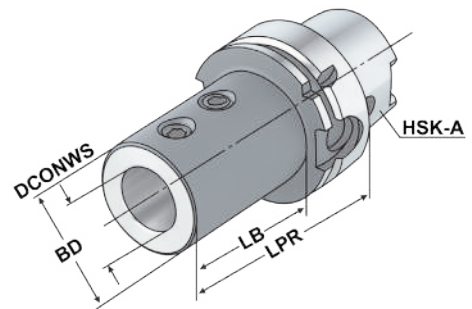

ISO 12164	Form A	≤ 4µm	G6.3 15.000 min ⁻¹	RFID Chip	ISO 9766	E1	H4
-----------	--------	-------	-------------------------------	-----------	----------	----	----

Bestell-Nr. Order no. Référence	HSK	DCONWS	LPR	BD	LB
A63.51.20	HSK-A 63	20	80	40	54
A63.51.25	HSK-A 63	25	90	45	59
A63.51.32	HSK-A 63	32	90	52	63
A63.51.40	HSK-A 63	40	105	63	73

5

Lieferumfang: Mit Spannschrauben
Delivery: With clamping screws
Livraison: Avec vis de serrage





Verwendung:
Zur Aufnahme von Werkzeugen mit Zylinderschaft.

Application:
For mounting tools with straight shanks.

Application:
Pour le serrage d'outils avec queue cylindrique.

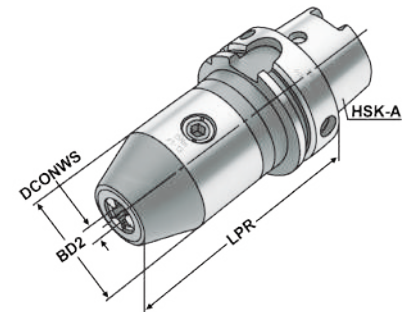

ISO 12164 Form A $\leq 30\mu\text{m}$ G6.3 15.000 min⁻¹ RFID Chip

13.04

5

Bestell-Nr. Order no. Référence	HSK	DCONWS Spannbereich Capacity Capacité	LPR	BD2	DRVS
A32.15.08	HSK-A 32	0 – 8	90	36	4
A40.15.08	HSK-A 40	0 – 8	90	36	4
A40.15.13	HSK-A 40	1,0 – 13	121	50	6
A40.15.16	HSK-A 40	2,5 – 16	126	50	6
A50.15.08	HSK-A 50	0 – 8	90	36	4
A50.15.13	HSK-A 50	1,0 – 13	116	50	6
A50.15.16	HSK-A 50	2,5 – 16	116	50	6
A63.15.08	HSK-A 63	0 – 8	85	36	4
A63.15.13	HSK-A 63	1,0 – 13	104	50	6
A63.15.16	HSK-A 63	2,5 – 16	109	50	6
A80.15.13	HSK-A 80	1,0 – 13	109	50	6
A80.15.16	HSK-A 80	2,5 – 16	114	50	6
A100.15.13	HSK-A 100	1,0 – 13	107	50	6
A100.15.16	HSK-A 100	2,5 – 16	112	50	6

Hinweis: Hohe Präzision und Rundlaufgenauigkeit von $\leq 0,03$ mm. Sichere Spannung des Werkzeuges durch mechanische Spannkraftverstärkung. Kein selbständiges Lösen der Spannung während der Bearbeitung bei Links- oder Rechtslauf, sowie bei Spindelstop. Spannen und Lösen mit Sechskantschlüssel.

Note: High precision and accurate concentricity of ≤ 0.03 mm. Secure gripping of the tool through mechanical amplification of the clamping force. No automatic slackening of the clamping force while machining with either clockwise or counter clockwise rotation or on spindle stop. Clamping and releasing effected by means of an Allen wrench.

Observation: Précision élevée et exactitude de circularité de $\leq 0,03$ mm. Serrage sûr de l'outil grâce à l'amplification de la force de serrage. Pas de desserrage intempestif en cours d'usinage lors de la rotation la gauche ou la droite, de même qu'en cas d'arrêt de la broche. Serrage et desserrage en utilisant un clé sur à fourche.

Lieferumfang: Ohne Spannschlüssel
Delivery: Without wrench
Livraison: Sans clé de serrage



Boring bar blanks
Barres d'alésage

Verwendung:
Zur Herstellung von Sonderwerkzeugen.

Application:
For the manufacturing of special tools.

Application:
Pour la fabrication d'outils spéciaux.

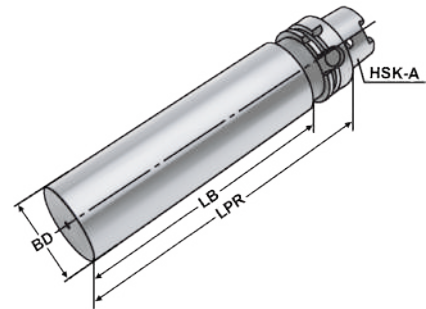
ISO
12164Form
ARFID
ChipBestell-Nr.
Order no.
Référence

HSK

BD

LPR

LB

A32.17.25

HSK-A 32

32,5

100

65

A40.17.40

HSK-A 40

40,5

160

125

A50.17.50

HSK-A 50

50,5

200

158

A63.17.63

HSK-A 63

63,5

250

208

A63.17.80

HSK-A 63

80,0

250

208

A80.17.80

HSK-A 80

80,5

250

234

A100.17.97

HSK-A 100

97,5

250

234

Ausführung: Kegel und Bund gehärtet und geschliffen. Schaft weich zur weiteren Bearbeitung.
Version: *Cone and flange hardened and grinded. Soft body for later processing.*
Version: Cône et collerette durcis et rectifiés. Corps doux pour un usinage ultérieur.

5



5.49

K Reduzierhülse zur Adaption von HSK auf PSK (ISO 12164 auf ISO 26623-1) | HSK-A

Reducing adapter for adaption from HSK to PSK (ISO 12164 to ISO 26623-1) (DIN 69893-1 | HSK-A)
 Douille de réduction pour adaptation de HSK à PSC (ISO 12164 à ISO 26623-1)



Verwendung:
 Zur Adaption von HSK-A auf PSK (ISO 12164 auf ISO 26623-1)
Application:
 For adaption from HSK-A to PSK (ISO 12164 to ISO 26623-1)
Application:
 Pour adaptation de HSK-A à PSC (ISO 12164 à ISO 26623-1).

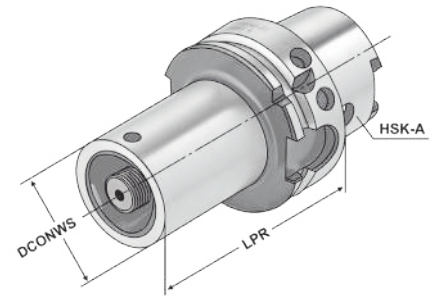

Bestell-Nr. Order no. Référence	HSK	Typ	DCONWS	LPR	TQX	THID
A63.09.C3	HSK-A 63	PSK C3	32	75	50	M12x1,5
A63.09.C4	HSK-A 63	PSK C4	40	80	50	M14x1,5
A63.09.C5	HSK-A 63	PSK C5	50	90	50	M16x1,5

5

Ausführung:

Adapter HSK / PSK mit Axialspannung. Innen und außen geschliffen. Das im PSK-Werkzeughalter für Kühlmittel-Rohre vorgesehene Innengewinde wird mit der im Adapter integrierten Zylinderkopfschraube verschraubt. Spannschraube durchbohrt, somit ist das System für Innenkühlung geeignet. Passend für Werkzeugaufnahmen mit Polygonschaft (PSC/PSK) ISO 26623-1.

Version:

Adapters HSK / PSK with axial clamping. Ground internally and externally. The internal thread provided for the coolant tube in the PSC toolholder is plugged with the socket-head screw incorporated in the adapter. The clamping screw incorporates a through hole, so the system is suitable for through-coolant feed. Suitable for tool arbor with polygonal shank (PSC) - ISO 26623-1.

Exécution:

Adaptateurs HSK / PSK Tension axiale. Intérieur et extérieur rectifiés. Le filetage intérieur prévu pour les conduits d'arrosage dans le porte-outils PSC est vissé à l'aide de la vis à tête cylindrique intégrée dans l'adaptateur. Système adapté à l'arrosage interne grâce à la vis de serrage percée. Pour la réception d'outils PSK ISO 26623-1.

Lieferumfang: Mit Spannschraube
Delivery: Clamping screw
Livraison: Avec vis de serrage





Hydraulic expansion chucks - slim design

Mandrins expansibles hydrauliques - type élané

(DIN 69893-1 | HSK-A)



Verwendung:

Zur Aufnahme von Werkzeugen mit Zylinderschaft. Besonders im Werkzeug- und Formenbau wo reduzierte Störkontur gefordert ist.

Application:

For mounting straight-shank tools. Especially in operations in toolmaking and mould making. Wherever reduced interference contours are required.

Application:

Pour le serrage d'outils avec queue cylindrique. Particulièrement dans la fabrication d'outils et de moules. Applications nécessitant un encombrement réduit.

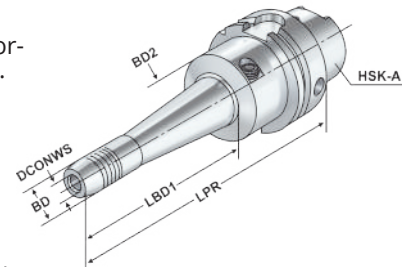

ISO 12164

Form A

$\leq 3\mu\text{m}$

G2.5
25.000
min⁻¹

RFID Chip

i
13.04

Bestell-Nr. Order no. Référence	HSK	DCONWS	LPR	BD	BD2	LSCX	ADJRGA	LBD1	DRVS	THID
A63.HSL06.160	HSK-A 63	6	160	16	50	37	10	103	5	M6x1
A63.HSL08.160	HSK-A 63	8	160	18	50	37	10	103	5	M6x1
A63.HSL10.160	HSK-A 63	10	160	20	50	42	10	103	5	M8x1
A63.HSL12.160	HSK-A 63	12	160	22	50	47	10	104	5	M8x1

LSCX = Einspannlänge, max.
LSCX = Clamping depth, max.
LSCX = Profondeur d'insertion, max.

ADJRGA = Verstellweg, max.
ADJRGA = Length adjustment range, max.
ADJRGA = Course de réglage, max.

Lieferumfang: Ohne Spanschlüssel
Delivery: Without wrench
Livraison: Sans clé de serrage



Gewuchtete Ausführung

Balanced type
Type équilibré



Bestell-Nr. Order no. Référence	Abmessung Size Dimension
---------------------------------------	--------------------------------

Wuchten auf G 2,5 von vorgewuchteten Kemmler-Werkzeugen

Balancing at G 2.5 of pre-balanced Kemmler-tools
Équilibrage G 2,5 d'outils Kemmler pré-équilibrés

W25 **Ohne Wuchtprotokoll**
Without balancing report
Sans protocole d'équilibrage

W25.2 **Mit Wuchtprotokoll**
With balancing report
Avec protocole d'équilibrage

Wuchten von nicht vorgewuchteten Werkzeugen
Balancing of unbalanced tools
Équilibrage d'outils non-équilibrés

W25.1 **Ohne Wuchtprotokoll**
Without balancing report
Sans protocole d'équilibrage



**Verwendung:**

Zur Aufnahme von Werkzeugen mit Zylinderschaft nach DIN 1835 Form A+B+E und DIN 6535 Form HB+HE (größer Ø 20 mm nur mit Reduzierung).

Application:

For mounting straight-shank tools acc. DIN 1835 form A+B+E and DIN 6535 form HB+HE (larger than Ø 20 mm only with reduction sleeve).

Application:

Pour le serrage d'outils avec queue cylindrique suivant DIN 1835 forme A+B+E et DIN 6535 forme HB+HE (à partir de Ø 20 mm seulement avec réduction).

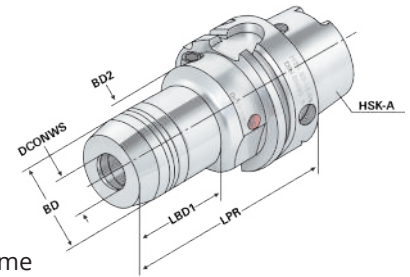

ISO 12164	Form A	≤ 3µm	G2.5 25.000 min ⁻¹	RFID Chip
-----------	--------	-------	-------------------------------	-----------

	13.04
--	-------

5

Bestell-Nr. Order no. Référence	HSK	DCONWS	LPR	BD	BD2	LSCX	ADJRGA	LBD1	DRVS	THID
A32.H06	HSK-A 32	6	80	26	33	37	10	31	5	M6x1
A32.H08	HSK-A 32	8	80	28	35	37	10	31	5	M6x1
A32.H10	HSK-A 32	10	85	30	37	42	10	36	5	M6x1
A32.H12	HSK-A 32	12	90	32	39	47	10	41	5	M6x1
A32.H14	HSK-A 32	14	95	34	26	47	10	60	5	M6x1
A32.H16	HSK-A 32	16	100	38	40	52	10	51	5	M8x1
A32.H20	HSK-A 32	20	100	42	42	52	10	65	5	M8x1
A40.H06	HSK-A 40	6	80	26	33,5	37	10	33	5	M6x1
A40.H08	HSK-A 40	8	80	28	33,5	37	10	33,5	5	M6x1
A40.H10	HSK-A 40	10	85	30	33,5	42	10	39	5	M6x1
A40.H12	HSK-A 40	12	90	32	33,5	47	10	44,5	5	M6x1
A40.H14	HSK-A 40	14	90	33,5	33,5	47	10	70	5	M6x1
A40.H16	HSK-A 40	16	90	38	50	52	10	38	5	M10x1
A40.H18	HSK-A 40	18	90	40	52	52	10	38	5	M10x1
A40.H20	HSK-A 40	20	90	42	54	52	10	38	5	M10x1
A50.H06	HSK-A 50	6	80	26	42	37	10	33	5	M6x1
A50.H08	HSK-A 50	8	80	28	42	37	10	33,5	5	M6x1
A50.H10	HSK-A 50	10	85	30	42	42	10	39	5	M8x1
A50.H12	HSK-A 50	12	90	32	42	47	10	44	5	M8x1
A50.H14	HSK-A 50	14	90	34	42	47	10	46	5	M10x1
A50.H16	HSK-A 50	16	95	38	42	52	10	51,5	5	M12x1
A50.H18	HSK-A 50	18	95	40	42	52	10	52	5	M12x1
A50.H20	HSK-A 50	20	100	42	42	52	10	74	5	M12x1
A50.H25	HSK-A 50	25	120	50	42	58	10	78	6	M12x1

LSCX = Einspannlänge, max.
LSCX = Clamping depth, max.
LSCX = Profondeur d'insertion, max.

ADJRGA = Verstellweg, max.
ADJRGA = Length adjustment range, max.
ADJRGA = Course de réglage, max.

Lieferumfang: Ohne Spannschlüssel
Delivery: Without wrench
Livraison: Sans clé de serrage





Hydraulic expansion chucks
Mandrins expansibles hydrauliques



Verwendung:
Zur Aufnahme von Werkzeugen mit Zylinderschaft nach DIN 1835 Form A+B+E und DIN 6535 Form HB+HE (größer Ø 20 mm nur mit Reduzierung).

Application:
For mounting straight-shank tools acc. DIN 1835 form A+B+E and DIN 6535 form HB+HE (larger than Ø 20 mm only with reduction sleeve).

Application:
Pour le serrage d'outils avec queue cylindrique suivant DIN 1835 forme A+B+E et DIN 6535 forme HB+HE (à partir de Ø 20 mm seulement avec réduction).

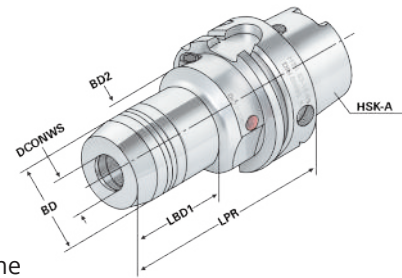

ISO 12164 Form A $\leq 3\mu\text{m}$ G2.5 25.000 min⁻¹ RFID Chip

13.04

Bestell-Nr. Order no. Référence	HSK	DCONWS	LPR	BD	BD2	LSCX	ADJRGA	LBD1	DRVS	THID
A63.H06	HSK-A 63	6	80	26	50	37	10	33	5	M6x1
A63.H08	HSK-A 63	8	80	28	50	37	10	33,5	5	M6x1
A63.H10	HSK-A 63	10	85	30	50	42	10	39	5	M8x1
A63.H12	HSK-A 63	12	90	32	50	47	10	44,5	5	M8x1
A63.H14	HSK-A 63	14	90	34	50	47	10	46	5	M10x1
A63.H16	HSK-A 63	16	95	38	50	52	10	51,5	5	M12x1
A63.H18	HSK-A 63	18	95	40	50	52	10	52	5	M12x1
A63.H20	HSK-A 63	20	100	42	50	52	10	58	5	M10x1
A63.H25	HSK-A 63	25	120	50	50	58	10	94	6	M16x1
A63.H32	HSK-A 63	32	125	60	53	62	10	83	6	M16x1
A63.H06.1	HSK-A 63	6	150	26	50	37	10	103	5	M6x1
A63.H08.1	HSK-A 63	8	150	28	50	37	10	104	5	M6x1
A63.H10.1	HSK-A 63	10	150	30	50	42	10	104	5	M8x1
A63.H12.1	HSK-A 63	12	150	32	50	47	10	105	5	M8x1
A63.H14.1	HSK-A 63	14	150	34	50	47	10	105	5	M10x1
A63.H16.1	HSK-A 63	16	150	38	50	52	10	106,5	5	M12x1
A63.H18.1	HSK-A 63	18	150	40	50	52	10	107	5	M12x1
A63.H20.1	HSK-A 63	20	150	42	50	52	10	108	5	M10x1
A63.H25.1	HSK-A 63	25	150	50	50	58	10	124	6	M16x1
A63.H06.2	HSK-A 63	6	200	26	50	37	10	153	5	M6x1
A63.H08.2	HSK-A 63	8	200	28	50	37	10	154	5	M6x1
A63.H10.2	HSK-A 63	10	200	30	50	42	10	154	5	M8x1
A63.H12.2	HSK-A 63	12	200	32	50	47	10	155	5	M8x1
A63.H14.2	HSK-A 63	14	200	34	50	47	10	155	5	M10x1
A63.H16.2	HSK-A 63	16	200	38	50	52	10	156,5	5	M12x1
A63.H18.2	HSK-A 63	18	200	40	50	52	10	157	5	M12x1
A63.H20.2	HSK-A 63	20	200	42	50	52	10	158	5	M10x1
A63.H25.2	HSK-A 63	25	200	50	50	58	10	174	6	M16x1

LSCX = Einspannlänge, max.
LSCX = Clamping depth, max.
LSCX = Profondeur d'insertion, max.

ADJRGA = Verstellweg, max.
ADJRGA = Length adjustment range, max.
ADJRGA = Course de réglage, max.

Lieferumfang: Ohne Spannschlüssel
Delivery: Without wrench
Livraison: Sans clé de serrage





Verwendung:

Zur Aufnahme von Werkzeugen mit Zylinderschaft nach DIN 1835 Form A+B+E und DIN 6535 Form HB+HE (größer Ø 20 mm nur mit Reduzierung).

Application:

For mounting straight-shank tools acc. DIN 1835 form A+B+E and DIN 6535 form HB+HE (larger than Ø 20 mm only with reduction sleeve).

Application:

Pour le serrage d'outils avec queue cylindrique suivant DIN 1835 forme A+B+E et DIN 6535 forme HB+HE (à partir de Ø 20 mm seulement avec réduction).

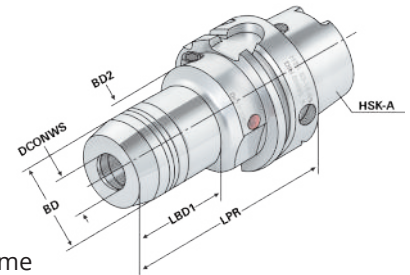

ISO 12164 Form A $\leq 3\mu\text{m}$ G7.5 25.000 min⁻¹ RFID Chip

13.04

5

Bestell-Nr. Order no. Référence	HSK	DCONWS	LPR	BD	BD2	LSCX	ADJRG	LBD1	DRVS	THID
A80.H06	HSK-A 80	6	85	26	56	37	10	54	5	M6x1
A80.H08	HSK-A 80	8	85	28	56	37	10	53	5	M6x1
A80.H10	HSK-A 80	10	90	30	56	42	10	53	5	M8x1
A80.H12	HSK-A 80	12	95	32	56	47	10	52	5	M10x1
A80.H14	HSK-A 80	14	95	34	56	47	10	51	5	M10x1
A80.H16	HSK-A 80	16	100	38	56	52	10	50	5	M12x1
A80.H18	HSK-A 80	18	100	40	56	52	10	50	5	M12x1
A80.H20	HSK-A 80	20	105	42	56	52	10	49	5	M12x1
A80.H25	HSK-A 80	25	115	50	56	58	10	62	5	M16x1
A80.H32	HSK-A 80	32	120	60	56	62	10	26	5	M16x1
A100.H06	HSK-A 100	6	85	26	63	37	10	33	5	M6x1
A100.H08	HSK-A 100	8	85	28	63	37	10	33,5	5	M6x1
A100.H10	HSK-A 100	10	90	30	63	42	10	39	5	M8x1
A100.H12	HSK-A 100	12	95	32	63	47	10	44,5	5	M8x1
A100.H14	HSK-A 100	14	95	34	63	47	10	46	5	M8x1
A100.H16	HSK-A 100	16	100	38	63	52	10	53	5	M12x1
A100.H18	HSK-A 100	18	100	40	63	52	10	52	5	M12x1
A100.H20	HSK-A 100	20	105	42	63	52	10	51	5	M12x1
A100.H25	HSK-A 100	25	115	50	63	58	10	64	6	M12x1
A100.H32	HSK-A 100	32	120	60	63	62	10	61	6	M12x1
A100.H06.1	HSK-A 100	6	150	26	63	37	10	97	5	M6
A100.H08.1	HSK-A 100	8	150	28	63	37	10	98	5	M6
A100.H10.1	HSK-A 100	10	150	30	63	42	10	99	5	M8x1
A100.H12.1	HSK-A 100	12	150	32	63	47	10	99	5	M8x1
A100.H14.1	HSK-A 100	14	150	34	63	47	10	101	5	M8x1
A100.H16.1	HSK-A 100	16	150	38	63	52	10	101	5	M12x1
A100.H18.1	HSK-A 100	18	150	40	63	52	10	102	5	M12x1
A100.H20.1	HSK-A 100	20	150	42	63	52	10	101	5	M12x1
A100.H25.1	HSK-A 100	25	150	50	63	58	10	99	6	M12x1
A100.H32.1	HSK-A 100	32	150	60	63	62	10	100	6	M12x1

LSCX = Einspannlänge, max.
LSCX = Clamping depth, max.
LSCX = Profondeur d'insertion, max.

ADJRG = Verstellweg, max.
ADJRG = Length adjustment range, max.
ADJRG = Course de réglage, max.

Lieferumfang: Ohne Spannschlüssel
Delivery: Without wrench
Livraison: Sans clé de serrage





Hydraulic expansion chucks
Mandrins expansibles hydrauliques



Verwendung:
Zur Aufnahme von Werkzeugen mit Zylinderschaft nach DIN 1835 Form A+B+E und DIN 6535 Form HB+HE (größer Ø 20 mm nur mit Reduzierung).

Application:
For mounting straight-shank tools acc. DIN 1835 form A+B+E and DIN 6535 form HB+HE (larger than Ø 20 mm only with reduction sleeve).

Application:
Pour le serrage d'outils avec queue cylindrique suivant DIN 1835 forme A+B+E et DIN 6535 forme HB+HE (à partir de Ø 20 mm seulement avec réduction).

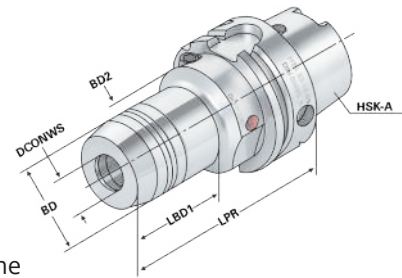

Bestell-Nr. Order no. Référence	HSK	DCONWS	LPR	BD	BD2	LSCX	ADJRGA	LBD1	DRVS	THID
A100.H06.2	HSK-A 100	6	200	26	50	37	10	56	5	M6x1
A100.H08.2	HSK-A 100	8	200	28	50	37	10	55,5	5	M6x1
A100.H10.2	HSK-A 100	10	200	30	50	42	10	55	5	M8x1
A100.H12.2	HSK-A 100	12	200	32	50	47	10	54,5	5	M10x1
A100.H14.2	HSK-A 100	14	200	34	50	47	10	53	5	M10x1
A100.H16.2	HSK-A 100	16	200	38	50	52	10	52,5	5	M12x1
A100.H18.2	HSK-A 100	18	200	40	50	52	10	52	5	M12x1
A100.H20.2	HSK-A 100	20	200	42	50	52	10	51	5	M12x1
A100.H25.2	HSK-A 100	25	200	50	50	58	10	-	6	M16x1
A100.H32.2	HSK-A 100	32	200	60	60	62	10	-	6	M16x1

LSCX = Einspannlänge, max. ADJRGA = Verstellweg, max.
LSCX = Clamping depth, max. ADJRGA = Length adjustment range, max.
LSCX = Profondeur d'insertion, max. ADJRGA = Course de réglage, max.

Lieferumfang: Ohne Spanschlüssel
Delivery: Without wrench
Livraison: Sans clé de serrage

5



Spannkraft-Prüfgerät für Hydrodehnspannfutter - Seite 12.59
Clamping force proofing instrument for hydraulic chucks - page 12.59
Appareil de contrôle des forces de serrage pour mandrin expansibles hydrauliques - page 12.59





Shrink chucks 4,5° for mounting of solid carbide and HSS-tool shanks

Mandrins de frettage 4,5° pour le serrage de queues d'outils carbures de type HM et HSS



Verwendung:

Zur Aufnahme von Werkzeugen mit Zylinderschaft.

Application:

For mounting straight-shank tools.

Application:

Pour le serrage d'outils avec queue cylindrique.

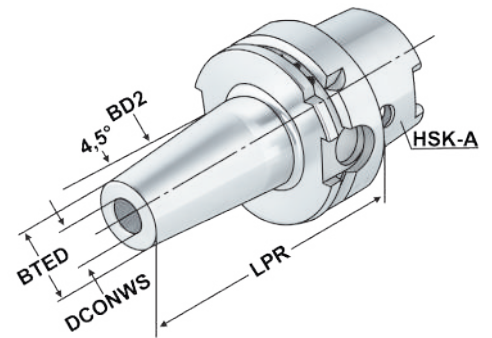

- ISO 12164
- Form A
- ≤ 3µm
- G7.5 25.000 min⁻¹
- RFID Chip
- h6

5

Bestell-Nr. Order no. Référence	HSK	DCONWS	TDCON	LPR	BTED	BD2	LSCN	LSCX	ADJRGA	THID
A32.70.03	HSK-A 32	3	h4	60	11	15	-	10	-	-
A32.70.04	HSK-A 32	4	h4	60	10	16	-	20	-	-
A32.70.05	HSK-A 32	5	h4	60	10	16	-	20	-	-
A32.70.06	HSK-A 32	6	h6	70	21	26	26	36	10	M5x0,8
A32.70.08	HSK-A 32	8	h6	70	21	26	26	36	10	M6x1
A32.70.10	HSK-A 32	10	h6	70	24	29	32	42	10	M8x1
A32.70.12	HSK-A 32	12	h6	90	24	29	37	47	10	M10x1
A32.70.14	HSK-A 32	14	h6	90	27	34	37	47	10	M10x1
A32.70.16	HSK-A 32	16	h6	90	27	34	40	50	10	M12x1
A32.70.20	HSK-A 32	20	h6	100	33	40	42	52	10	M12x1
A40.70.03	HSK-A 40	3	h4	80	11	15	-	10	-	-
A40.70.04	HSK-A 40	4	h4	80	14	22	-	20	-	-
A40.70.05	HSK-A 40	5	h4	80	16	22	-	20	-	-
A40.70.06	HSK-A 40	6	h6	80	21	27	26	36	10	M5x0,8
A40.70.08	HSK-A 40	8	h6	80	21	27	26	36	10	M6x1
A40.70.10	HSK-A 40	10	h6	80	24	32	32	42	10	M8x1
A40.70.12	HSK-A 40	12	h6	90	24	32	37	47	10	M10x1
A40.70.14	HSK-A 40	14	h6	90	27	34	37	47	10	M10x1
A40.70.16	HSK-A 40	16	h6	90	27	34	40	50	10	M12x1
A40.70.18	HSK-A 40	18	h6	95	33	42	40	50	10	M12x1
A40.70.20	HSK-A 40	20	h6	100	33	42	42	52	10	M16x1
A40.70.25	HSK-A 40	25	h6	100	44	51	48	58	10	M16x1

LSCX = Einspannlänge, max.
 LSCX = Clamping depth, max.
 LSCX = Profondeur d'insertion, max.

ADJRGA = Verstellweg, max.
 ADJRGA = Length adjustment range, max.
 ADJRGA = Course de réglage, max.

Für Ø 3, 4 und 5 mm nur Hartmetallschäfte verwenden!

For Ø 3, 4 and 5 mm only solid carbide tool shanks must be used!

Pour Ø 3, 4 et 5 mm il faut seulement utiliser de queues d'outils carbures de type HM!

Hinweis: Aufnahme für Induktiv-, Kontakt- und Heiluftschumpfergerte geeignet. Schafttoleranz bei Ø 3, 4 und 5 mm = h4, bei Ø 6 - Ø 32 mm = h6

Note: Toolholders suitable for induction-, contact- and hot air shrink units. Ø 3, 4, 5 with h4-tolerance and Ø 6 - Ø 32 with h6-tolerance

Observation: Porte-outils convenables pour machines à fretter par induction, par contact, ou par air chaud. Ø 3, 4, 5 avec h4-tolerance et Ø 6 - Ø 32 avec h6-tolerance



Shrink chucks 4,5° for mounting of solid carbide and HSS-tool shanks

Mandrins de frettage 4,5° pour le serrage de queues d'outils carbures de type HM et HSS



Verwendung:
Zur Aufnahme von Werkzeugen mit Zylinderschaft.

Application:
For mounting straight-shank tools.

Application:
Pour le serrage d'outils avec queue cylindrique.

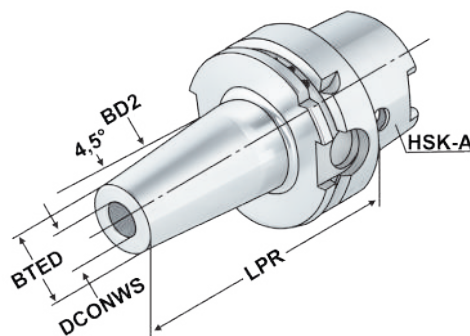

ISO 12164 Form A $\leq 3\mu\text{m}$ G2.5 25.000 min⁻¹ RFID Chip h6

Bestell-Nr. Order no. Référence	HSK	DCONWS	TDCON	LPR	BTED	BD2	LSCN	LSCX	ADJRGA	THID
A50.70.03	HSK-A 50	3	h4	80	11	15	-	18	-	-
A50.70.04	HSK-A 50	4	h4	80	14	22	-	20	-	-
A50.70.05	HSK-A 50	5	h4	80	16	22	-	20	-	-
A50.70.06	HSK-A 50	6	h6	80	21	27	26	36	10	M5x0,8
A50.70.08	HSK-A 50	8	h6	80	21	27	26	36	10	M6x1
A50.70.10	HSK-A 50	10	h6	85	24	32	32	42	10	M8x1
A50.70.12	HSK-A 50	12	h6	90	24	32	37	47	10	M10x1
A50.70.14	HSK-A 50	14	h6	90	27	34	37	47	10	M10x1
A50.70.16	HSK-A 50	16	h6	95	27	34	40	50	10	M12x1
A50.70.18	HSK-A 50	18	h6	95	33	42	40	50	10	M12x1
A50.70.20	HSK-A 50	20	h6	100	33	42	42	52	10	M16x1
A50.70.25	HSK-A 50	25	h6	115	44	53	48	58	10	M16x1
A50.70.32	HSK-A 50	32	h6	120	44	53	52	62	10	M16x1
A50.70.06.1	HSK-A 50	6	h6	120	21	27	26	36	10	M5x0,8
A50.70.08.1	HSK-A 50	8	h6	120	21	27	26	36	10	M6x1
A50.70.10.1	HSK-A 50	10	h6	120	24	32	32	42	10	M8x1
A50.70.12.1	HSK-A 50	12	h6	120	24	32	32	42	10	M10x1
A50.70.14.1	HSK-A 50	14	h6	120	27	34	37	47	10	M10x1
A50.70.16.1	HSK-A 50	16	h6	120	27	34	40	50	10	M12x1
A50.70.18.1	HSK-A 50	18	h6	120	33	42	40	50	10	M12x1
A50.70.20.1	HSK-A 50	20	h6	120	33	42	42	52	10	M16x1
A50.70.03.2	HSK-A 50	3	h4	160	11	15	-	10	-	-
A50.70.04.2	HSK-A 50	4	h4	160	14	22	15	20	5	-
A50.70.05.2	HSK-A 50	5	h4	160	16	22	15	20	5	-
A50.70.06.2	HSK-A 50	6	h6	160	21	27	26	36	10	M5x0,8
A50.70.08.2	HSK-A 50	8	h6	160	21	27	26	36	10	M6x1
A50.70.10.2	HSK-A 50	10	h6	160	24	32	32	42	10	M8x1
A50.70.12.2	HSK-A 50	12	h6	160	24	32	37	47	10	M10x1
A50.70.14.2	HSK-A 50	14	h6	160	27	34	37	47	10	M10x1
A50.70.16.2	HSK-A 50	16	h6	160	27	34	40	50	10	M12x1
A50.70.18.2	HSK-A 50	18	h6	160	33	42	40	50	10	M12x1
A50.70.20.2	HSK-A 50	20	h6	160	33	42	42	52	10	M16x1





Shrink chucks 4,5° for mounting of solid carbide and HSS-tool shanks

Mandrins de frettage 4,5° pour le serrage de queues d'outils carbures de type HM et HSS



Verwendung:

Zur Aufnahme von Werkzeugen mit Zylinderschaft.

Application:

For mounting straight-shank tools.

Application:

Pour le serrage d'outils avec queue cylindrique.

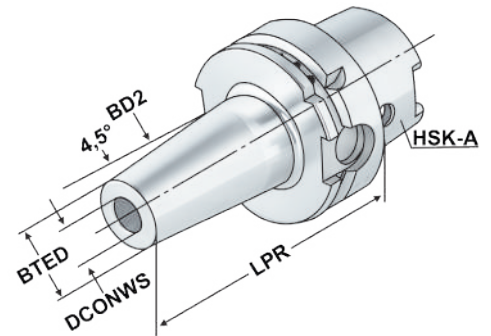

- ISO 12164
- Form A
- ≤ 3µm
- G2.5 25.000 min⁻¹
- RFID Chip
- h6

5

Bestell-Nr. Order no. Référence	HSK	DCONWS	TDCON	LPR	BTED	BD2	LSCN	LSCX	ADJRGA	THID
A63.70.03	HSK-A 63	3	h4	80	11	15	9	-	-	-
A63.70.04	HSK-A 63	4	h4	80	14	22	9	-	-	-
A63.70.05	HSK-A 63	5	h4	80	16	22	10	-	-	-
A63.70.06	HSK-A 63	6	h6	80	21	27	22	36	10	M5x0,8
A63.70.08	HSK-A 63	8	h6	80	21	27	26	36	10	M6x1
A63.70.10	HSK-A 63	10	h6	85	24	32	31	41	10	M8x1
A63.70.12	HSK-A 63	12	h6	90	24	32	36	46	10	M10x1
A63.70.14	HSK-A 63	14	h6	90	27	34	36	46	10	M10x1
A63.70.16	HSK-A 63	16	h6	95	27	34	39	49	10	M12x1
A63.70.18	HSK-A 63	18	h6	95	33	42	39	49	10	M12x1
A63.70.20	HSK-A 63	20	h6	100	33	42	41	51	10	M16x1
A63.70.25	HSK-A 63	25	h6	115	44	53	47	57	10	M16x1
A63.70.32	HSK-A 63	32	h6	120	44	53	51	61	10	M16x1
A63.70.03.1	HSK-A 63	3	h4	120	11	15	9	-	-	-
A63.70.04.1	HSK-A 63	4	h4	120	14	22	9	-	-	-
A63.70.05.1	HSK-A 63	5	h4	120	16	22	10	-	-	-
A63.70.06.1	HSK-A 63	6	h6	120	21	27	22	36	10	M5x0,8
A63.70.08.1	HSK-A 63	8	h6	120	21	27	26	36	10	M6x1
A63.70.10.1	HSK-A 63	10	h6	120	24	32	31	41	10	M8x1
A63.70.12.1	HSK-A 63	12	h6	120	24	32	36	46	10	M10x1
A63.70.14.1	HSK-A 63	14	h6	120	27	34	36	46	10	M10x1
A63.70.16.1	HSK-A 63	16	h6	120	27	34	39	49	10	M12x1
A63.70.18.1	HSK-A 63	18	h6	120	33	42	39	49	10	M12x1
A63.70.20.1	HSK-A 63	20	h6	120	33	42	41	51	10	M16x1

Für Ø 3, 4 und 5 mm nur Hartmetallschäfte verwenden!

For Ø 3, 4 and 5 mm only solid carbide tool shanks must be used!

Pour Ø 3, 4 et 5 mm il faut seulement utiliser de queues d'outils carbures de type HM!

Hinweis: Aufnahme für Induktiv-, Kontakt- und Heißluftschumpfgeräte geeignet. Schafttoleranz bei Ø 3, 4 und 5 mm = h₄, bei Ø 6 - Ø 32 mm = h₆

Note: Toolholders suitable for induction-, contact- and hot air shrink units. Ø 3, 4, 5 with h₄-tolerance and Ø 6 - Ø 32 with h₆-tolerance

Observation: Porte-outils convenables pour machines à fretter par induction, par contact, ou par air chaud. Ø 3, 4, 5 avec h₄-tolerance et Ø 6 - Ø 32 avec h₆-tolerance

LSCX = Einspannlänge, max.
LSCX = Clamping depth, max.
LSCX = Profondeur d'insertion, max.

ADJRGA = Verstellweg, max.
ADJRGA = Length adjustment range, max.
ADJRGA = Course de réglage, max.





Shrink chucks 4,5° for mounting of solid carbide and HSS-tool shanks

Mandrins de frettage 4,5° pour le serrage de queues d'outils carbures de type HM et HSS



Verwendung:
Zur Aufnahme von Werkzeugen mit Zylinderschaft.

Application:
For mounting straight-shank tools.

Application:
Pour le serrage d'outils avec queue cylindrique.

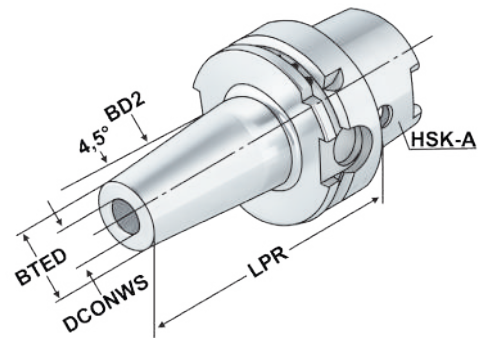

ISO 12164 Form A $\leq 3\mu\text{m}$ G2.5 25.000 min⁻¹ RFID Chip h6

Bestell-Nr. Order no. Référence	HSK	DCONWS	TDCON	LPR	BTED	BD2	LSCN	LSCX	ADJRGA	THID
A63.70.03.2	HSK-A 63	3	h4	160	11	15	9	-	-	-
A63.70.04.2	HSK-A 63	4	h4	160	14	22	9	-	-	-
A63.70.05.2	HSK-A 63	5	h4	160	16	22	10	-	-	-
A63.70.06.2	HSK-A 63	6	h6	160	21	27	22	36	10	M5x0,8
A63.70.08.2	HSK-A 63	8	h6	160	21	27	26	36	10	M6x1
A63.70.10.2	HSK-A 63	10	h6	160	24	32	31	41	10	M8x1
A63.70.12.2	HSK-A 63	12	h6	160	24	32	36	46	10	M10x1
A63.70.14.2	HSK-A 63	14	h6	160	27	34	36	46	10	M10x1
A63.70.16.2	HSK-A 63	16	h6	160	27	34	39	49	10	M12x1
A63.70.18.2	HSK-A 63	18	h6	160	33	42	39	49	10	M12x1
A63.70.20.2	HSK-A 63	20	h6	160	33	42	41	51	10	M16x1
A63.70.25.2	HSK-A 63	25	h6	160	44	53	47	57	10	M16x1
A63.70.32.2	HSK-A 63	32	h6	160	44	53	51	61	10	M16x1
A63.70.06.3	HSK-A 63	6	h6	200	21	27	22	36	10	M5x0,8
A63.70.08.3	HSK-A 63	8	h6	200	21	27	26	36	10	M6x1
A63.70.10.3	HSK-A 63	10	h6	200	24	32	31	41	10	M8x1
A63.70.12.3	HSK-A 63	12	h6	200	24	32	36	46	10	M10x1
A63.70.14.3	HSK-A 63	14	h6	200	27	34	36	46	10	M10x1
A63.70.16.3	HSK-A 63	16	h6	200	27	34	39	49	10	M12x1
A63.70.18.3	HSK-A 63	18	h6	200	33	42	39	49	10	M12x1
A63.70.20.3	HSK-A 63	20	h6	200	33	42	41	51	10	M16x1
A63.70.25.3	HSK-A 63	25	h6	200	44	53	47	57	10	M16x1
A63.70.32.3	HSK-A 63	32	h6	200	44	53	51	61	10	M16x1

5

Für Ø 3, 4 und 5 mm nur Hartmetallschäfte verwenden!

For Ø 3, 4 and 5 mm only solid carbide tool shanks must be used!

Pour Ø 3, 4 et 5 mm il faut seulement utiliser de queues d'outils carbures de type HM!

Hinweis: Aufnahme für Induktiv-, Kontakt- und Heißluftschumpfergeräte geeignet. Schafttoleranz bei Ø 3, 4 und 5 mm = h₄, bei Ø 6 - Ø 32 mm = h₆

Note: Toolholders suitable for induction-, contact- and hot air shrink units. Ø 3, 4, 5 with h₄-tolerance and Ø 6 - Ø 32 with h₆-tolerance

Observation: Porte-outils convenables pour machines à fretter par induction, par contact, ou par air chaud. Ø 3, 4, 5 avec h₄-tolerance et Ø 6 - Ø 32 avec h₆-tolerance



LSCX = Einspannlänge, max.
LSCX = Clamping depth, max.
LSCX = Profondeur d'insertion, max.

ADJRGA = Verstellweg, max.
ADJRGA = Length adjustment range, max.
ADJRGA = Course de réglage, max.



Shrink chucks 4,5° for mounting of solid carbide and HSS-tool shanks

Mandrins de frettage 4,5° pour le serrage de queues d'outils carbures de type HM et HSS



Verwendung:
Zur Aufnahme von Werkzeugen mit Zylinderschaft.

Application:
For mounting straight-shank tools.

Application:
Pour le serrage d'outils avec queue cylindrique.

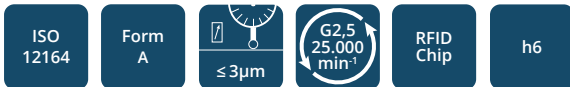
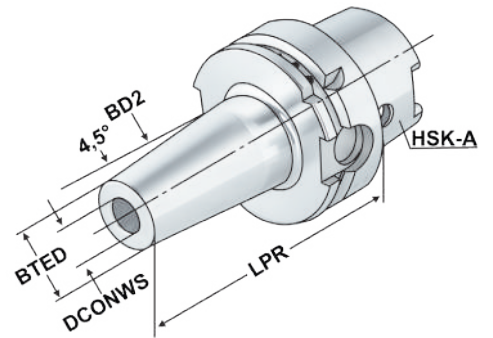

5

Bestell-Nr. Order no. Référence	HSK	DCONWS	TDCON	LPR	BTED	BD2	LSCN	LSCX	ADJRGA	THID
A80.70.04	HSK-A 80	4	h4	80	14	22	-	10	-	-
A80.70.06	HSK-A 80	6	h6	85	21	27	26	36	10	M5x0,8
A80.70.08	HSK-A 80	8	h6	85	21	27	26	36	10	M6x1
A80.70.10	HSK-A 80	10	h6	90	24	32	32	42	10	M8x1
A80.70.12	HSK-A 80	12	h6	95	24	32	37	47	10	M10x1
A80.70.14	HSK-A 80	14	h6	95	27	34	37	47	10	M10x1
A80.70.16	HSK-A 80	16	h6	100	27	34	40	50	10	M12x1
A80.70.18	HSK-A 80	18	h6	100	33	42	40	50	10	M12x1
A80.70.20	HSK-A 80	20	h6	105	33	42	42	52	10	M16x1
A80.70.25	HSK-A 80	25	h6	115	44	53	48	58	10	M16x1
A80.70.32	HSK-A 80	32	h6	120	44	53	52	62	10	M16x1
A80.70.06.1	HSK-A 80	6	h6	120	21	27	26	36	10	M5x0,8
A80.70.08.1	HSK-A 80	8	h6	120	21	27	26	36	10	M6x1
A80.70.10.1	HSK-A 80	10	h6	120	24	32	32	42	10	M8x1
A80.70.12.1	HSK-A 80	12	h6	120	24	32	37	47	10	M10x1
A80.70.14.1	HSK-A 80	14	h6	120	27	34	37	47	10	M10x1
A80.70.06.2	HSK-A 80	6	h6	160	21	27	26	36	10	M5x0,8
A80.70.08.2	HSK-A 80	8	h6	160	21	27	26	36	10	M6x1
A80.70.10.2	HSK-A 80	10	h6	160	24	32	32	42	10	M8x1
A80.70.12.2	HSK-A 80	12	h6	160	24	32	37	47	10	M10x1
A80.70.14.2	HSK-A 80	14	h6	160	27	34	37	47	10	M10x1
A80.70.16.2	HSK-A 80	16	h6	160	27	34	40	50	10	M12x1
A80.70.18.2	HSK-A 80	18	h6	160	33	42	40	50	10	M12x1
A80.70.20.2	HSK-A 80	20	h6	160	33	42	42	52	10	M16x1
A80.70.25.2	HSK-A 80	25	h6	160	44	53	48	58	10	M16x1

LSCX = Einspannlänge, max. ADJRGA = Verstellweg, max.
 LSCX = Clamping depth, max. ADJRGA = Length adjustment range, max.
 LSCX = Profondeur d'insertion, max. ADJRGA = Course de réglage, max.

Für Ø 3, 4 und 5 mm nur Hartmetallschäfte verwenden!
For Ø 3, 4 and 5 mm only solid carbide tool shanks must be used!
 Pour Ø 3, 4 et 5 mm il faut seulement utiliser de queues d'outils carbures de type HM!

Hinweis: Aufnahme für Induktiv-, Kontakt- und Heißluftschumpfergeräte geeignet.
 Schafttoleranz bei Ø 3, 4 und 5 mm = h₄, bei Ø 6 - Ø 32 mm = h₆

Note: Toolholders suitable for induction-, contact- and hot air shrink units.
 Ø 3, 4, 5 with h₄-tolerance and Ø 6 - Ø 32 with h₆-tolerance

Observation: Porte-outils convenables pour machines à fretter par induction,
 par contact, ou par air chaud.
 Ø 3, 4, 5 avec h₄-tolerance et Ø 6 - Ø 32 avec h₆-tolerance





Shrink chucks 4,5° for mounting of solid carbide and HSS-tool shanks

Mandrins de frettage 4,5° pour le serrage de queues d'outils carbures de type HM et HSS



Verwendung:
Zur Aufnahme von Werkzeugen mit Zylinderschaft.

Application:
For mounting straight-shank tools.

Application:
Pour le serrage d'outils avec queue cylindrique.

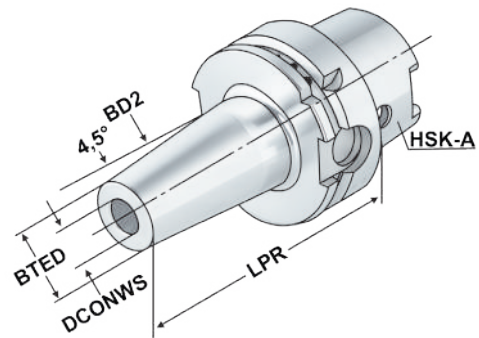

ISO 12164

Form A

$\leq 3\mu\text{m}$

$G2.5$

 25.000

 min^{-1}

RFID Chip

h6

Bestell-Nr. Order no. Référence	HSK	DCONWS	TDCON	LPR	BTED	BD2	LSCN	LSCX	ADJRGA	THID
A100.70.04	HSK-A 100	4	h4	85	14	22	8	-	-	-
A100.70.05	HSK-A 100	5	h4	85	16	22	10	-	-	-
A100.70.06	HSK-A 100	6	h6	85	21	27	22	36	10	M5x0,8
A100.70.08	HSK-A 100	8	h6	85	21	27	26	36	10	M6x1
A100.70.10	HSK-A 100	10	h6	90	24	32	31	41	10	M8x1
A100.70.12	HSK-A 100	12	h6	95	24	32	36	46	10	M10x1
A100.70.14	HSK-A 100	14	h6	95	27	34	36	46	10	M10x1
A100.70.16	HSK-A 100	16	h6	100	27	34	39	49	10	M12x1
A100.70.18	HSK-A 100	18	h6	100	33	42	39	49	10	M12x1
A100.70.20	HSK-A 100	20	h6	105	33	42	41	51	10	M16x1
A100.70.25	HSK-A 100	25	h6	120	44	53	47	57	10	M16x1
A100.70.32	HSK-A 100	32	h6	120	44	53	51	61	10	M16x1
A100.70.40	HSK-A 100	40	h6	150	78	90	80	90	10	M16x1
A100.70.50	HSK-A 100	50	h6	150	78	90	80	90	10	M16x1
A100.70.06.1	HSK-A 100	6	h6	120	21	27	22	36	10	M5x0,8
A100.70.08.1	HSK-A 100	8	h6	120	21	27	26	36	10	M6x1
A100.70.10.1	HSK-A 100	10	h6	120	24	32	31	41	10	M8x1
A100.70.12.1	HSK-A 100	12	h6	120	24	32	36	46	10	M10x1
A100.70.14.1	HSK-A 100	14	h6	120	27	34	36	46	10	M10x1
A100.70.16.1	HSK-A 100	16	h6	120	27	34	39	49	10	M12x1
A100.70.18.1	HSK-A 100	18	h6	120	33	42	39	49	10	M12x1
A100.70.20.1	HSK-A 100	20	h6	120	33	42	41	51	10	M16x1
A100.70.06.2	HSK-A 100	6	h6	160	21	27	22	36	10	M5x0,8
A100.70.08.2	HSK-A 100	8	h6	160	21	27	26	36	10	M6x1
A100.70.10.2	HSK-A 100	10	h6	160	24	32	31	41	10	M8x1
A100.70.12.2	HSK-A 100	12	h6	160	24	32	36	46	10	M10x1
A100.70.14.2	HSK-A 100	14	h6	160	27	34	36	46	10	M10x1
A100.70.16.2	HSK-A 100	16	h6	160	27	34	39	49	10	M12x1
A100.70.18.2	HSK-A 100	18	h6	160	33	42	39	49	10	M12x1
A100.70.20.2	HSK-A 100	20	h6	160	33	42	41	51	10	M16x1
A100.70.25.2	HSK-A 100	25	h6	160	44	53	47	57	10	M16x1
A100.70.32.2	HSK-A 100	32	h6	160	44	53	51	61	10	M16x1





Shrink chucks 4,5° for mounting of solid carbide and HSS-tool shanks

Mandrins de frettage 4,5° pour le serrage de queues d'outils carbures de type HM et HSS



Verwendung:

Zur Aufnahme von Werkzeugen mit Zylinderschaft.

Application:

For mounting straight-shank tools.

Application:

Pour le serrage d'outils avec queue cylindrique.

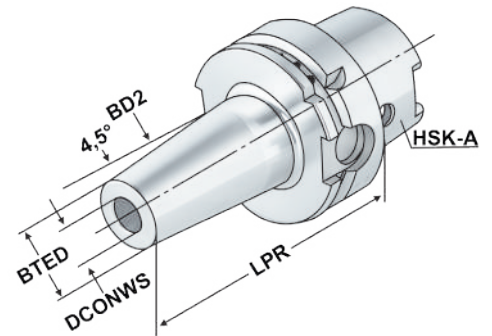

ISO 12164	Form A	≤ 3µm	G2.5 25.000 min ⁻¹	RFID Chip	h6
-----------	--------	-------	-------------------------------	-----------	----

5

Bestell-Nr. Order no. Référence	HSK	DCONWS	TDCON	LPR	BTED	BD2	LSCN	LSCX	ADJRGA	THID
A100.70.06.3	HSK-A 100	6	h6	200	21	27	22	36	10	M5x0,8
A100.70.08.3	HSK-A 100	8	h6	200	21	27	26	36	10	M6x1
A100.70.10.3	HSK-A 100	10	h6	200	24	32	31	41	10	M8x1
A100.70.12.3	HSK-A 100	12	h6	200	24	32	36	46	10	M10x1
A100.70.14.3	HSK-A 100	14	h6	200	27	34	36	46	10	M10x1
A100.70.16.3	HSK-A 100	16	h6	200	27	34	39	49	10	M12x1
A100.70.18.3	HSK-A 100	18	h6	200	33	42	39	49	10	M12x1
A100.70.20.3	HSK-A 100	20	h6	200	33	42	41	51	10	M16x1
A100.70.25.3	HSK-A 100	25	h6	200	44	53	47	57	10	M16x1
A100.70.32.3	HSK-A 100	32	h6	200	44	53	51	61	10	M16x1
A100.70.06.4	HSK-A 100	6	h6	250	21	27	22	36	10	M5x0,8
A100.70.08.4	HSK-A 100	8	h6	250	21	27	26	36	10	M6x1
A100.70.10.4	HSK-A 100	10	h6	250	24	32	31	41	10	M8x1
A100.70.12.4	HSK-A 100	12	h6	250	24	32	36	46	10	M10x1
A100.70.14.4	HSK-A 100	14	h6	250	27	34	36	46	10	M10x1
A100.70.16.4	HSK-A 100	16	h6	250	27	34	39	49	10	M12x1

LSCX = Einspannlänge, max. ADJRGA = Verstellweg, max.
 LSCX = Clamping depth, max. ADJRGA = Length adjustment range, max.
 LSCX = Profondeur d'insertion, max. ADJRGA = Course de réglage, max.

Für Ø 3, 4 und 5 mm nur Hartmetallschäfte verwenden!
For Ø 3, 4 and 5 mm only solid carbide tool shanks must be used!
 Pour Ø 3, 4 et 5 mm il faut seulement utiliser de queues d'outils carbures de type HM!

Hinweis: Aufnahme für Induktiv-, Kontakt- und Heißluftschrimpferäte geeignet.
 Schafttoleranz bei Ø 3, 4 und 5 mm = h₄, bei Ø 6 - Ø 32 mm = h₆

Note: Toolholders suitable for induction-, contact- and hot air shrink units.
 Ø 3, 4, 5 with h₄-tolerance and Ø 6 - Ø 32 with h₆-tolerance

Observation: Porte-outils convenables pour machines à fretter par induction,
 par contact, ou par air chaud.
 Ø 3, 4, 5 avec h₄-tolerance et Ø 6 - Ø 32 avec h₆-tolerance





Shrink chucks 4,5° for mounting of solid carbide and HSS-tool shanks

Mandrins de frettage 4,5° pour le serrage de queues d'outils carbures de type HM et HSS



Verwendung:
Zur Aufnahme von Werkzeugen mit Zylinderschaft.

Application:
For mounting straight-shank tools.

Application:
Pour le serrage d'outils avec queue cylindrique.

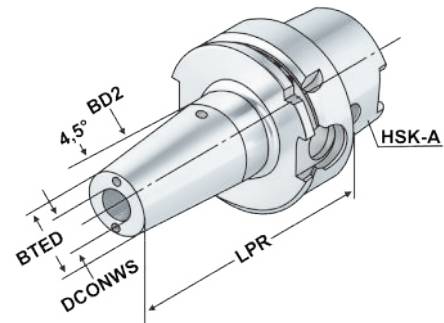

Bestell-Nr. Order no. Référence	HSK	DCONWS	TDCON	LPR	BTED	BD2	LSCN	LSCX	ADJRGA	THID
A63.70.03.K	HSK-A 63	3	h4	80	11	15	9	-	-	-
A63.70.04.K	HSK-A 63	4	h4	80	14	22	9	-	-	-
A63.70.05.K	HSK-A 63	5	h6	80	16	22	10	-	-	-
A63.70.06.K	HSK-A 63	6	h6	80	21	27	22	36	10	M5x0,8
A63.70.08.K	HSK-A 63	8	h6	80	21	27	26	36	10	M6x1
A63.70.10.K	HSK-A 63	10	h6	85	24	32	31	41	10	M8x1
A63.70.12.K	HSK-A 63	12	h6	90	24	32	36	46	10	M10x1
A63.70.14.K	HSK-A 63	14	h6	90	27	34	36	46	10	M10x1
A63.70.16.K	HSK-A 63	16	h6	95	27	34	39	49	10	M12x1
A63.70.18.K	HSK-A 63	18	h6	95	33	42	39	49	10	M12x1
A63.70.20.K	HSK-A 63	20	h6	100	33	42	41	51	10	M16x1
A63.70.25.K	HSK-A 63	25	h6	115	44	53	48	58	10	M16x1
A63.70.32.K	HSK-A 63	32	h6	120	44	53	51	61	10	M16x1
A63.70.03.1.K	HSK-A 63	3	h6	120	11	15	-	-	-	-
A63.70.04.1.K	HSK-A 63	4	h6	120	14	22	-	-	-	-
A63.70.05.1.K	HSK-A 63	5	h6	120	16	22	-	-	-	-
A63.70.06.1.K	HSK-A 63	6	h6	120	21	27	22	36	10	M5x0,8
A63.70.08.1.K	HSK-A 63	8	h6	120	21	27	26	36	10	M6x1
A63.70.10.1.K	HSK-A 63	10	h6	120	24	32	31	41	10	M8x1
A63.70.12.1.K	HSK-A 63	12	h6	120	24	32	36	46	10	M10x1
A63.70.14.1.K	HSK-A 63	14	h6	120	27	34	36	46	10	M10x1
A63.70.16.1.K	HSK-A 63	16	h6	120	27	34	39	49	10	M12x1
A63.70.18.1.K	HSK-A 63	18	h6	120	33	42	39	49	10	M12x1
A63.70.20.1.K	HSK-A 63	20	h6	120	33	42	41	51	10	M16x1

LSCX = Einspannlänge, max.
LSCX = Clamping depth, max.
LSCX = Profondeur d'insertion, max.

ADJRGA = Verstellweg, max.
ADJRGA = Length adjusting range, max.
ADJRGA = Course de réglage, max.

Für Ø 3, 4 und 5 mm nur Hartmetallschäfte verwenden!

For Ø 3, 4 and 5 mm only solid carbide tool shanks must be used!

Pour Ø 3, 4 et 5 mm il faut seulement utiliser de queues d'outils carbures de type HM!

Hinweis: Aufnahme für Induktiv-, Kontakt- und Heißluftschumpfergeräte geeignet. Schafttoleranz bei Ø 3, 4 und 5 mm = h₄, bei Ø 6 - Ø 32 mm = h₆

Note: Toolholders suitable for induction-, contact- and hot air shrink units. Ø 3, 4, 5 with h₄-tolerance and Ø 6 - Ø 32 with h₆-tolerance

Observation: Porte-outils convenables pour machines à fretter par induction, par contact, ou par air chaud. Ø 3, 4, 5 avec h₄-tolerance et Ø 6 - Ø 32 avec h₆-tolerance



Shrink chucks 4,5° for mounting of solid carbide and HSS-tool shanks

Mandrins de frettage 4,5° pour le serrage de queues d'outils carbures de type HM et HSS



Verwendung:

Zur Aufnahme von Werkzeugen mit Zylinderschaft.

Application:

For mounting straight-shank tools.

Application:

Pour le serrage d'outils avec queue cylindrique.

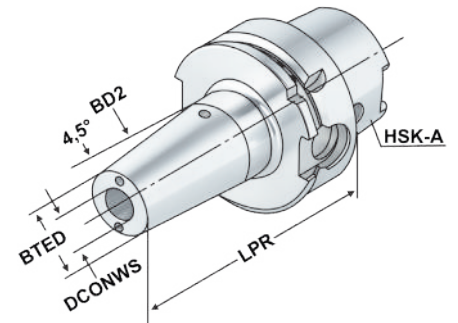

- ISO 12164
- Form A
- $\leq 3\mu\text{m}$
- G2.5 25.000 min⁻¹
- RFID Chip
- h6
-

5

Bestell-Nr. Order no. Référence	HSK	DCONWS	TDCON	LPR	BTED	BD2	LSCN	LSCX	ADJRGA	THID
A63.70.06.2.K	HSK-A 63	6	h6	160	21	27	26	36	10	M5x0,8
A63.70.08.2.K	HSK-A 63	8	h6	160	21	27	26	36	10	M6x1
A63.70.10.2.K	HSK-A 63	10	h6	160	24	32	41	42	10	M8x1
A63.70.12.2.K	HSK-A 63	12	h6	160	24	32	37	47	10	M10x1
A63.70.14.2.K	HSK-A 63	14	h6	160	27	34	37	47	10	M10x1
A63.70.16.2.K	HSK-A 63	16	h6	160	27	34	40	50	10	M12x1
A63.70.18.2.K	HSK-A 63	18	h6	160	33	42	40	50	10	M12x1
A63.70.20.2.K	HSK-A 63	20	h6	160	33	42	42	52	10	M16x1
A63.70.25.2.K	HSK-A 63	25	h6	160	44	53	48	58	10	M16x1
A63.70.32.2.K	HSK-A 63	32	h6	160	44	53	51	61	10	M16x1
A100.70.05.K	HSK-A 100	5	h4	80	16	22	-	-	-	-
A100.70.06.K	HSK-A 100	6	h6	80	21	27	26	36	10	M5x0,8
A100.70.08.K	HSK-A 100	8	h6	80	21	27	26	36	10	M6x1
A100.70.10.K	HSK-A 100	10	h6	85	24	32	41	42	10	M8x1
A100.70.12.K	HSK-A 100	12	h6	90	24	32	46	47	10	M10x1
A100.70.14.K	HSK-A 100	14	h6	90	27	34	46	47	10	M10x1
A100.70.16.K	HSK-A 100	16	h6	95	27	34	40	50	10	M12x1
A100.70.18.K	HSK-A 100	18	h6	95	33	42	40	50	10	M12x1
A100.70.20.K	HSK-A 100	20	h6	100	33	42	42	52	10	M16x1
A100.70.25.K	HSK-A 100	25	h6	120	44	53	48	58	10	M16x1
A100.70.32.K	HSK-A 100	32	h6	120	44	53	51	61	10	M16x1
A100.70.05.1.K	HSK-A 100	5	h4	120	16	22	10	-	-	-
A100.70.06.1.K	HSK-A 100	6	h6	120	21	27	26	36	10	M5x0,8
A100.70.08.1.K	HSK-A 100	8	h6	120	21	27	26	36	10	M6x1
A100.70.10.1.K	HSK-A 100	10	h6	120	24	32	42	42	10	M8x1
A100.70.12.1.K	HSK-A 100	12	h6	120	24	32	37	47	10	M10x1
A100.70.14.1.K	HSK-A 100	14	h6	120	27	34	37	47	10	M10x1
A100.70.16.1.K	HSK-A 100	16	h6	120	27	34	40	50	10	M12x1
A100.70.18.1.K	HSK-A 100	18	h6	120	33	42	40	50	10	M12x1
A100.70.20.1.K	HSK-A 100	20	h6	120	33	42	42	52	10	M16x1
A100.70.25.1.K	HSK-A 100	25	h6	120	44	53	48	58	10	M16x1
A100.70.32.1.K	HSK-A 100	32	h6	120	44	53	51	61	10	M16x1

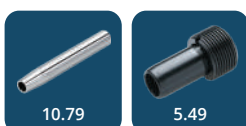



Shrink chucks 3° for mounting of solid carbide and HSS-tool shanks - slim

Mandrins de frettage 3° pour le serrage de queues d'outils carbures de type HM et HSS - élané



Verwendung:
Zur Aufnahme von Werkzeugen mit Zylinderschaft.

Application:
For mounting straight-shank tools.

Application:
Pour le serrage d'outils avec queue cylindrique.

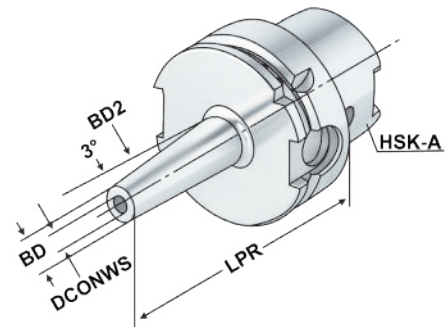

ISO 12164 Form A $\leq 3\mu\text{m}$ G2.5 25.000 min⁻¹ RFID Chip h6

Bestell-Nr. Order no. Référence	HSK	DCONWS	TDCON	LPR	BTED	BD2	LSCN	LSCX	ADJRGA	THID
A63.72.03	HSK-A 63	3	h4	80	9	15,5	6	-	-	-
A63.72.04	HSK-A 63	4	h4	80	10	16,5	8	-	-	-
A63.72.05	HSK-A 63	5	h4	80	11	17,5	10	-	-	-
A63.72.06	HSK-A 63	6	h6	80	12	18,5	22	36	10	M5x0,8
A63.72.08	HSK-A 63	8	h6	80	14	20,5	26	36	10	M6x1
A63.72.10	HSK-A 63	10	h6	80	16	22,5	31	41	10	M8x1
A63.72.12	HSK-A 63	12	h6	80	18	24,5	36	46	10	M10x1
A63.72.03.1	HSK-A 63	3	h4	120	9	19,5	6	-	-	-
A63.72.04.1	HSK-A 63	4	h4	120	10	20,5	8	-	-	-
A63.72.05.1	HSK-A 63	5	h4	120	11	21,5	10	-	-	-
A63.72.06.1	HSK-A 63	6	h6	120	12	22,5	22	36	10	M5x0,8
A63.72.08.1	HSK-A 63	8	h6	120	14	24,5	26	36	10	M6x1
A63.72.10.1	HSK-A 63	10	h6	120	16	26,5	31	41	10	M8x1
A63.72.12.1	HSK-A 63	12	h6	120	18	28,5	36	46	10	M10x1
A63.72.04.2	HSK-A 63	4	h4	160	10	24	8	-	-	-
A63.72.05.2	HSK-A 63	5	h4	160	11	25	10	-	-	-
A63.72.06.2	HSK-A 63	6	h6	160	12	26,5	22	36	10	M5x0,8
A63.72.08.2	HSK-A 63	8	h6	160	14	28,5	26	36	10	M6x1
A63.72.10.2	HSK-A 63	10	h6	160	16	30,5	31	41	10	M8x1
A63.72.12.2	HSK-A 63	12	h6	160	18	32,5	36	46	10	M10x1

LSCX = Einspannlänge, max. ADJRGA = Verstellweg, max.
 LSCX = Clamping depth, max. ADJRGA = Length adjustment range, max.
 LSCX = Profondeur d'insertion, max. ADJRGA = Course de réglage, max.

Ausführung: schlanke Bauform (reduzierte Störkontur)
Version: slim design (reduced interference contour)
Version: Modèle très étroit (encombrement réduit)

Für Ø 3, 4 und 5 mm nur Hartmetallschäfte verwenden!
 For Ø 3, 4 and 5 mm only solid carbide tool shanks must be used!
 Pour Ø 3, 4 et 5 mm il faut seulement utiliser de queues d'outils carbures de type HM!

Hinweis: Aufnahmen für Induktiv-, Kontakt- und Heißluftschumpfergeräte geeignet.
 Schafttoleranz bei Ø 3, 4 und 5 mm = h₄, bei Ø 6 - Ø 32 mm = h₆

Note: Toolholders suitable for induction-, contact- and hot air shrink units.
 Ø 3, 4, 5 with h₄-tolerance and Ø 6 - Ø 32 with h₆-tolerance

Observation: Porte-outils convenables pour machines à fretter par induction, par contact, ou par air chaud.
 Ø 3, 4, 5 avec h₄-tolerance et Ø 6 - Ø 32 avec h₆-tolerance





Verwendung:
Zur Aufnahme von Werkzeugen mit Zylinderschaft.

Application:
For mounting straight-shank tools.

Application:
Pour le serrage d'outils avec queue cylindrique.

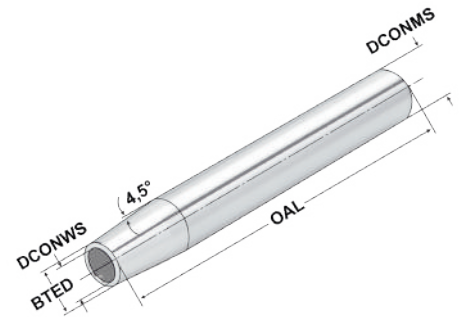

Bestell-Nr. Order no. Référence	DCONMS	DCONWS	BTED	OAL	LSCN	LSCX	ADJRGA	THID
120.70.03	20	3	10	150	6	-	-	-
120.70.04	20	4	10	150	8	-	-	-
120.70.05	20	5	10	150	10	-	-	-
120.70.06*	20	6	10	150	22	36	10	M5x0,8
120.70.08*	20	8	12	150	26	36	10	M6x1
120.70.10*	20	10	14	150	31	41	10	M8x1
120.70.12*	20	12	16	150	36	46	10	M10x1

* mit Anschlag | * with end stop | * avec butée

Durchgangsbohrung für Innenkühlung vorhanden.
Through hole for internal cooling provided.
Trou débouchant disponible pour arrosage interne.

LSCX = Einspannlänge, max. ADJRGA = Verstellweg, max.
LSCX = Clamping depth, max. ADJRGA = Length adjustment range, max.
LSCX = Profondeur d'insertion, max. ADJRGA = Course de réglage, max.

Für Ø 3, 4 und 5 mm nur Hartmetallschäfte verwenden!
For Ø 3, 4 and 5 mm only solid carbide tool shanks must be used!
Pour Ø 3, 4 et 5 mm il faut seulement utiliser de queues d'outils carbures de type HM!

Hinweis: Aufnahmen für Induktiv-, Kontakt- und Heißluftschumpfergeräte geeignet.
Schafttoleranz bei Ø 3, 4 und 5 mm = h₄, bei Ø 6 – Ø 32 mm = h₆

Note: Toolholders suitable for induction-, contact- and hot air shrink units.
Ø 3, 4, 5 with h₄-tolerance and Ø 6 – Ø 32 with h₆-tolerance

Observation: Porte-outils convenables pour machines à fretter par induction, par contact, ou par air chaud.
Ø 3, 4, 5 avec h₄-tolerance et Ø 6 – Ø 32 avec h₆-tolerance

Test arbors
Mandrins de contrôle



Verwendung:
Zur Abnahme von Werkzeugmaschinen gemäß ISO-Empfehlung R230 oder zur Überprüfung der Werkzeugspindel.

Application:
For the inspection of machine tools according to ISO recommendation R230 or for testing the tool spindle.

Application:
Pour l'inspection de machine-outils suite à la recommandation ISO R230 ou pour la vérification de la broche.

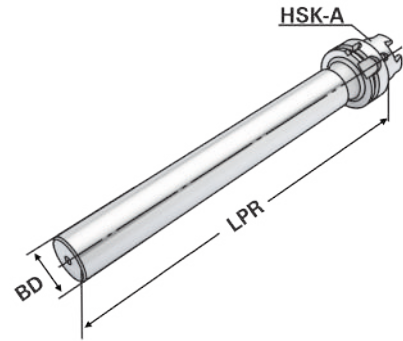

Bestell-Nr. Order no. Référence	HSK	BD	LPR	Toleranz Tolerance Tolérance	max. Rundlaufabweichung max. concentricity deviation Faux-rond max.
A32.18.25	HSK-A 32	25	200	0,003	0,003
A40.18.25	HSK-A 40	25	200	0,003	0,003
A50.18.32	HSK-A 50	32	346	0,003	0,003
A63.18.40	HSK-A 63	40	346	0,003	0,003
A80.18.50	HSK-A 80	40	346	0,003	0,003
A100.18.50	HSK-A 100	50	329	0,003	0,003

5

Lieferumfang: Auslieferung mit Prüfprotokoll
Delivery: Delivery with test certificate
Livraison: Livraison avec rapport d'essais

Holzkasten für Kontrolldorne

Wooden box for test arbors
Coffret en bois pour mandrins de contrôle



Verwendung:
Zur Aufbewahrung von Kontrolldornen.

Application:
For the storage of test arbors.

Application:
Pour la conservation de mandrins de contrôle.



Bestell-Nr. Order no. Référence	Abmessung Size Dimension	für Kegelgrößen for cones pour cônes
701.18	460 × 130 × 115	HSK 32 / 40 / 50 / 63 / 80 / 100



Verwendung:
Zur zentralen Übergabe von Kühlmittel bei HSK-Werkzeugaufnahmen.

Application:
For the coolant supply through the centre of HSK toolholders.

Application:
Pour l'arrosage centrale de porte-outils HSK.

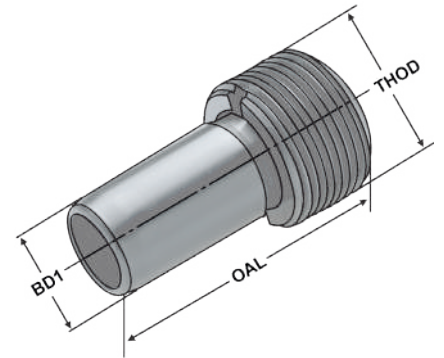

DIN 69895 Form A + E

5

Bestell-Nr. Order no. Référence	HSK	THOD	BD1	OAL	TQX
A32.700	HSK 32	M10 × 1	6	26,0	5
A40.700	HSK 40	M12 × 1	8	29,5	10
A50.700	HSK 50	M16 × 1	10	33,0	15
A63.700	HSK 63	M18 × 1	12	34,5	20
A80.700	HSK 80	M20 × 1,5	14	40,0	25
A100.700	HSK 100	M24 × 1,5	16	44,0	30

- Hinweis:** Nach DIN 69895 für HSK-A und HSK-E Kegel-Hohlschäfte
Axial abgedichtet mit zwei O-Ringen
Dichtigkeit der Verschraubung getestet bis 80 bar
Die Kühlmittelübergabeeinheit ist nach dem Einbau, gemäß DIN, minimal beweglich (±1°)
- Note:** According to DIN 69895 for HSK-A and HSK-E hollow taper shanks
Axial sealed with two O-rings
Tightness of the screw connection tested up to 80 bar
After mounting, the coolant tube can be moved only to a minimum degree according to DIN (±1°)
- Observation:** Selon DIN 69895 pour HSK-A et HSK-E Tiges creuses coniques
Étanche axiale avec deux joints toriques
étanchéité du raccord testée jusqu'à 80 bar
Après le montage, la canule de lubrification peut être déplacée légèrement suivant DIN (±1°)



Key for coolant tubes
Clés pour canules de lubrification



Verwendung:
Zum Montieren der Kühlmittelübergabeeinheiten in HSK-Werkzeugaufnahmen.

Application:
For mounting the coolant tubes in HSK toolholders.

Application:
Pour le montage de canules de lubrification dans des porte-outils HSK.

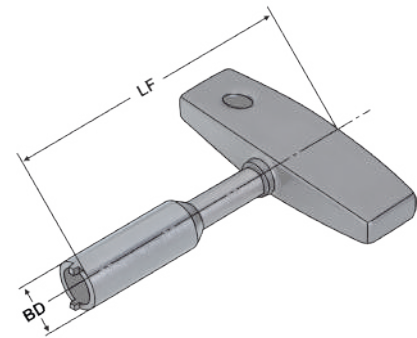

ISO
12164

Form
A

Bestell-Nr.
Order no.
Référence

HSK

BD

LF

A32.701

HSK 32

8,5

115

A40.701

HSK 40

10,5

115

A50.701

HSK 50

14,5

115

A63.701

HSK 63

16,5

136

A80.701

HSK 80

18,5

136

A100.701

HSK 100

22,0

136

5

Vorgewuchtet
Pre-balanced
 Pré-équilibré

G 6,3 15.000 min⁻¹

G 2,5 Feinwuchten gegen Aufpreis
G 2.5 Fine balancing at extra charge
 G 2,5 Equilibrage fin contre un supplément

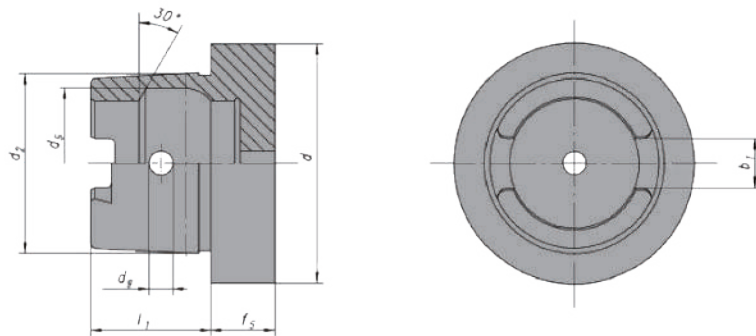

5

d ₁	l ₁	f ₅	d ₂	d ₅	d ₉	b ₁
32	16	10	24	21	4	7,05
40	20	10	30	25,5	4,6	8,05
50	25	12,5	38	32	6	10,54
63	32	12,5	48	40	7,5	12,54
80	40	16	60	50	8,5	16,04
100	50	16	75	63	12	20,02

Werkstoff: Legierter Einsatzstahl mit einer Zugfestigkeit im Kern von min. 950 N / mm². Einsatzgehärtet HRC 60 ± 2 (HV 700 ± 50), Härtetiefe 0,8 mm ± 0,2 mm, brüniert und präzisionsgeschliffen.

Genauigkeit: Kegelwinkel – Toleranzqualität < AT 3 nach DIN 7187.

Material: *Alloyed case-hardened steel, tensile core strength of min. 950 N / mm². Case hardened HRC 60 ± 2 (HV 700 ± 50), hardening depth 0.8 mm ± 0.2 mm, black-finished and precisely grinded.*

Accuracy: *Quality of taper < AT 3 according to DIN 7187.*

Matière: Acier de cémentation allié. Résistance à la traction dans le noyau de min 950 N / mm². Cémentation à HRC 60 ± 2 (HV 700 ± 50), profondeur de cémentation 0,8 mm ± 0,2 mm, bruni et rectifié précisément.

Précision: Qualité du cône < AT 3 suivant DIN 7187.

Normative Verweise:

ISO 12164-1:2001-12
 Hohlkegelschnittstelle mit Plananlage
 - Teil 1: Schäfte; Maße

Normative references:

ISO 12164-1:2001
 Hollow taper interface with flange contact surface
 - Part 1: Shanks; Dimensions

Références normatives:

ISO 12164-1:2001
 Interfaces à cône creux-face
 - Partie 1: Queues; Dimensions

DIN 69893-1:2011
 Kegel-Hohlschäfte mit Plananlage besteht aus:
 - Teil 1: Kegel-Hohlschäfte Form A und Form C;
 Maße und Ausführung

DIN 69893-1:2011
 Hollow taper shanks with flange contact surface:
 - Part 1: Hollow taper shanks type A and type C;
 Dimensions and design

DIN 69893-1:2011
 Queues creuses coniques à surface de contact plane:
 - Partie 1: Queues creuses coniques type A et type C;
 Dimensions et conception



Index
Sommaire

5.53



5.54



5.58



5.59



5.60



5.61



5.63



5.65





Verwendung:
 Zur Aufnahme von Werkzeugen mit Zylinderschaft in Spannzangen.

Application:
 For mounting straight-shank tools in collets.

Application:
 Destiné à recevoir les outils avec les queues de forme cylindrique dans les pinces de serrage.

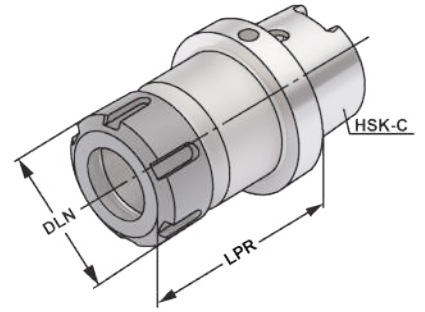

5

Bestell-Nr. Order no. Référence	HSK	DCONWS Spannbereich Capacity Capacité	Typ	LPR	DLN
C25.02.07.M ¹	HSK-C 25	1 - 7	4008E ER 11 Mini	40	16
C25.02.10.M ¹	HSK-C 25	1 - 10	426E ER 16 Mini	55	22
C32.02.10 ²	HSK-C 32	1 - 10	426E ER 16	60	28
C40.02.10.M ¹	HSK-C 40	1 - 10	426E ER 16 Mini	70	22
C40.02.10 ²	HSK-C 40	1 - 10	426E ER 16	60	28
C40.02.16	HSK-C 40	2 - 16	430E ER 25	70	42
C40.02.20	HSK-C 40	2 - 20	470E ER 32	75	50
C40.02.26	HSK-C 40	3 - 26	472E ER 40	85	63
C50.02.10 ²	HSK-C 50	1 - 10	426E ER 16	60	28
C50.02.10.1	HSK-C 50	1 - 10	426E ER 16	100	28
C50.02.16	HSK-C 50	2 - 16	430E ER 25	70	42
C50.02.20	HSK-C 50	2 - 20	470E ER 32	80	50
C50.02.26	HSK-C 50	3 - 26	472E ER 40	80	63
C63.02.10 ²	HSK-C 63	1 - 10	426E ER 16	60	28
C63.02.10.1	HSK-C 63	1 - 10	426E ER 16	100	28
C63.02.16	HSK-C 63	2 - 16	430E ER 25	70	42
C63.02.20	HSK-C 63	2 - 20	470E ER 32	75	50
C63.02.26	HSK-C 63	3 - 26	472E ER 40	80	63
C80.02.10 ²	HSK-C 80	1 - 10	426E ER 16	100	28
C80.02.10.1	HSK-C 80	1 - 10	426E ER 16	160	28
C80.02.20	HSK-C 80	2 - 20	470E ER 32	80	50
C80.02.26	HSK-C 80	3 - 26	472E ER 40	85	63
C100.02.10 ²	HSK-C 100	1 - 10	426E ER 16	100	28
C100.02.10.1 ²	HSK-C 100	1 - 10	426E ER 16	160	28
C100.02.20	HSK-C 100	2 - 20	470E ER 32	80	50
C100.02.26	HSK-C 100	3 - 26	472E ER 40	90	63

¹ Minimutter
¹ Mini nut
¹ Ecrous mini

² Sechskantmutter
² Hexagonal clamping nut
² Ecrous hexagonal

Lieferumfang: Mit gewichteter Spannmutter
Delivery: With balanced clamping nut
Livraison: Avec écrou de serrage équilibré



End mill holders DIN 6359 for end mills DIN 1835-B

DIN 69893 | HSK-C

Porte-fraises DIN 6359 pour queues cylindriques DIN 1835-B

**Verwendung:**

Zum Spannen von zylindrischen Werkzeugschäften mit seitlicher Spannfläche nach DIN 1835 Form B (Weldon).

Application:

For mounting straight-shank tools with lateral flat according to DIN 1835 form B (Weldon).

Application:

Pour le serrage d'outils avec queue cylindrique et avec méplat de serrage latérale suivant DIN 1835 forme B (Weldon).

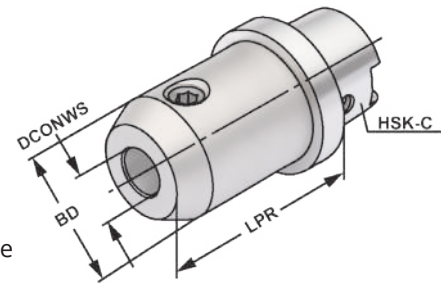

Bestell-Nr. Order no. Référence	HSK	DCONWS	TDCON	LPR	BD
C40.04.08	HSK-C 40	8	H4	60	28
C40.04.10	HSK-C 40	10	H4	70	35
C40.04.12	HSK-C 40	12	H4	70	42
C40.04.14	HSK-C 40	14	H4	75	44
C40.04.16	HSK-C 40	16	H4	75	48
C40.04.18	HSK-C 40	18	H4	80	50
C40.04.20	HSK-C 40	20	H4	80	52
C50.04.06	HSK-C 50	6	H4	60	25
C50.04.08	HSK-C 50	8	H4	60	28
C50.04.10	HSK-C 50	10	H4	65	35
C50.04.12	HSK-C 50	12	H4	75	42
C50.04.14	HSK-C 50	14	H4	75	44
C50.04.16	HSK-C 50	16	H4	80	48
C50.04.18	HSK-C 50	18	H4	80	50
C50.04.20	HSK-C 50	20	H4	80	50
C50.04.25	HSK-C 50	25	H4	80	50
C63.04.06	HSK-C 63	6	H4	60	25
C63.04.08	HSK-C 63	8	H4	60	28
C63.04.10	HSK-C 63	10	H4	65	35
C63.04.12	HSK-C 63	12	H4	75	42
C63.04.14	HSK-C 63	14	H4	75	44
C63.04.16	HSK-C 63	16	H4	80	48
C63.04.18	HSK-C 63	18	H4	80	50
C63.04.20	HSK-C 63	20	H4	80	52
C63.04.25	HSK-C 63	25	H4	95	65
C63.04.32	HSK-C 63	32	H4	100	72

Hinweis: Ab DCONWS = 25 mit zwei Spannschrauben
Note: From DCONWS = 25 on two clamping screws
Observation: A partir de DCONWS = 25 avec deux vis de serrage

Lieferumfang: Mit Spannschraube
Delivery: With clamping screw
Livraison: Avec vis de serrage



**Verwendung:**

Zum Spannen von zylindrischen Werkzeugschäften mit seitlicher Spannfläche nach DIN 1835 Form B (Weldon).

Application:

For mounting straight-shank tools with lateral flat according to DIN 1835 form B (Weldon).

Application:

Pour le serrage d'outils avec queue cylindrique et avec méplat de serrage latérale suivant DIN 1835 forme B (Weldon).

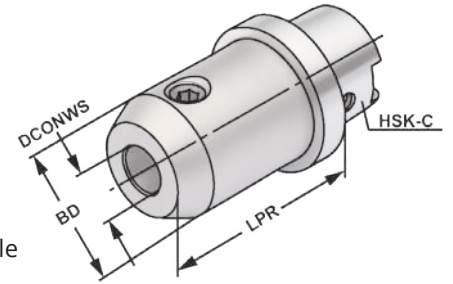

ISO 12164	Form C	≤ 3µm	G6.3 15.000 min ⁻¹	DIN 1835-B	H4	13.04
-----------	--------	-------	-------------------------------	------------	----	-------

5

Bestell-Nr. Order no. Référence	HSK	DCONWS	TDCON	LPR	BD
C100.04.06	HSK-C 100	6	H4	65	25
C100.04.08	HSK-C 100	8	H4	65	28
C100.04.10	HSK-C 100	10	H4	70	35
C100.04.12	HSK-C 100	12	H4	75	42
C100.04.14	HSK-C 100	14	H4	75	44
C100.04.16	HSK-C 100	16	H4	80	48
C100.04.18	HSK-C 100	18	H4	80	50
C100.04.20	HSK-C 100	20	H4	85	52
C100.04.25	HSK-C 100	25	H4	95	65
C100.04.32	HSK-C 100	32	H4	100	72
C100.04.40	HSK-C 100	40	H4	100	80

Hinweis: Ab DCONWS = 25 mit zwei Spannschrauben
Note: From DCONWS = 25 on two clamping screws
Observation: A partir de DCONWS = 25 avec deux vis de serrage

Lieferumfang: Mit Spannschraube
Delivery: With clamping screw
Livraison: Avec vis de serrage

Gewuchtete Ausführung**Balanced type
Type équilibré**

Bestell-Nr. Order no. Référence	Abmessung Size Dimension
---------------------------------------	--------------------------------

Wuchten auf G 2,5 von vorgewuchteten Kemmler-Werkzeugen

Balancing at G 2.5 of pre-balanced Kemmler-tools
 Equilibrage sur G 2,5 d'outils Kemmler pré-équilibrés

W25 **Ohne Wuchtprotokoll**
Without balancing report
Sans protocole d'équilibrage

W25.2 **Mit Wuchtprotokoll**
With balancing report
Avec protocole d'équilibrage

Wuchten von nicht vorgewuchteten Werkzeugen

Balancing of unbalanced tools
 Equilibrage d'outils non-équilibrés
 W25.1 **Ohne Wuchtprotokoll**
Without balancing report
Sans protocole d'équilibrage



End mill holders DIN 6359 for end mills DIN 1835-E

DIN 69893 | HSK-C

Porte-fraises DIN 6359 pour queues cylindriques DIN 1835-E

**Verwendung:**

Zum Spannen von zylindrischen Werkzeugschäften mit geneigter Spannfläche nach DIN 1835 Form E (Whistle Notch).

Application:

For mounting straight-shank tools and inclined flat according to DIN 1835 form E (Whistle Notch).

Application:

Pour le serrage d'outils avec queue cylindrique et avec méplat incliné suivant DIN 1835 forme E (Whistle Notch).

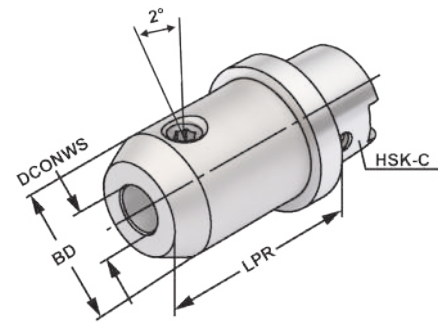

Bestell-Nr. Order no. Référence	HSK	DCONWS	TDCON	LPR	BD
C32.05.06	HSK-C 32	6	H4	60	25
C32.05.08	HSK-C 32	8	H4	60	28
C32.05.10	HSK-C 32	10	H4	65	35
C32.05.12	HSK-C 32	12	H4	70	42
C32.05.14	HSK-C 32	14	H4	70	44
C40.05.06	HSK-C 40	6	H4	60	25
C40.05.08	HSK-C 40	8	H4	60	28
C40.05.10	HSK-C 40	10	H4	65	35
C40.05.12	HSK-C 40	12	H4	70	40
C40.05.14	HSK-C 40	14	H4	70	40
C40.05.16	HSK-C 40	16	H4	75	40
C40.05.18	HSK-C 40	18	H4	75	40
C40.05.20	HSK-C 40	20	H4	80	48
C40.05.25	HSK-C 40	25	H4	100	46
C50.05.06	HSK-C 50	6	H4	60	25
C50.05.08	HSK-C 50	8	H4	60	28
C50.05.10	HSK-C 50	10	H4	65	35
C50.05.12	HSK-C 50	12	H4	75	42
C50.05.14	HSK-C 50	14	H4	75	44
C50.05.16	HSK-C 50	16	H4	80	48
C50.05.18	HSK-C 50	18	H4	80	50
C50.05.20	HSK-C 50	20	H4	80	52
C50.05.25	HSK-C 50	25	H4	85	65

Hinweis: Ab DCONWS = 25 mit zwei Spannschrauben
Note: From DCONWS = 25 on two clamping screws
Observation: A partir de DCONWS = 25 avec deux vis de serrage

Lieferumfang: Mit Spannschraube und axialer Verstellechraube
Delivery: With clamping screw and axial adjustment bolt
Livraison: Avec vis de serrage et vis de butée axiale





Verwendung:
 Zum Spannen von zylindrischen
 Werkzeugschäften mit geneigter Spann-
 fläche nach DIN 1835 Form E (Whistle
 Notch).

Application:
 For mounting straight-shank tools and
 inclined flat according to DIN 1835 form E
 (Whistle Notch).

Application:
 Pour le serrage d'outils avec queue
 cylindrique et avec méplat incliné
 suivant DIN 1835 forme E (Whistle
 Notch).

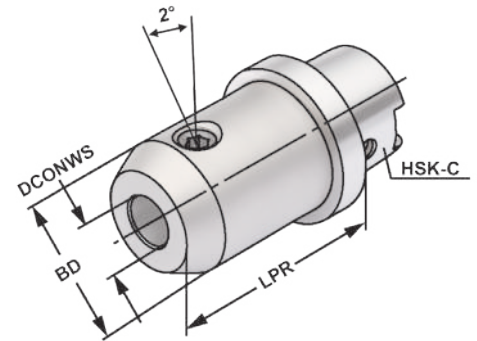

5

Bestell-Nr. Order no. Référence	HSK	DCONWS	TDCON	LPR	BD
C63.05.06	HSK-C 63	6	H4	60	25
C63.05.08	HSK-C 63	8	H4	60	28
C63.05.10	HSK-C 63	10	H4	65	35
C63.05.12	HSK-C 63	12	H4	75	42
C63.05.14	HSK-C 63	14	H4	75	44
C63.05.16	HSK-C 63	16	H4	80	48
C63.05.18	HSK-C 63	18	H4	80	50
C63.05.20	HSK-C 63	20	H4	80	52
C63.05.25	HSK-C 63	25	H4	95	65
C63.05.32	HSK-C 63	32	H4	100	72
C80.05.06	HSK-C 80	6	H4	65	25
C80.05.08	HSK-C 80	8	H4	65	28
C80.05.10	HSK-C 80	10	H4	70	35
C80.05.12	HSK-C 80	12	H4	75	42
C80.05.14	HSK-C 80	14	H4	75	44
C80.05.16	HSK-C 80	16	H4	80	48
C80.05.18	HSK-C 80	18	H4	80	50
C80.05.20	HSK-C 80	20	H4	85	52
C80.05.25	HSK-C 80	25	H4	95	65
C80.05.32	HSK-C 80	32	H4	100	72
C100.05.06	HSK-C 100	6	H4	65	25
C100.05.08	HSK-C 100	8	H4	65	28
C100.05.10	HSK-C 100	10	H4	70	35
C100.05.12	HSK-C 100	12	H4	75	42
C100.05.14	HSK-C 100	14	H4	75	44
C100.05.16	HSK-C 100	16	H4	80	48
C100.05.18	HSK-C 100	18	H4	80	50
C100.05.20	HSK-C 100	20	H4	85	52
C100.05.25	HSK-C 100	25	H4	95	65
C100.05.32	HSK-C 100	32	H4	100	72

Hinweis: Ab DCONWS = 25 mit zwei Spannschrauben
Note: From DCONWS = 25 on two clamping screws
Observation: A partir de DCONWS = 25 avec deux vis de serrage

Lieferumfang: Mit Spannschraube und axialer Verstellechraube
Delivery: With clamping screw and axial adjustment bolt
Livraison: Avec vis de serrage et vis de butée axiale

Shell mill holders DIN 6357 with enlarged contact face
 Porte-fraises à trou lisse DIN 6357 avec face de contact élargie



Verwendung:
 Zur Aufnahme von Messerköpfen und Fräsern mit Quernut.

Application:
 For mounting milling cutters with transversal groove.

Application:
 Destiné à recevoir les fraises et les fraises avec des rainures transversales.

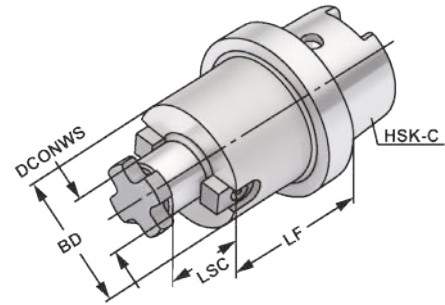

ISO 12164

Form C

$\leq 5\mu\text{m}$

G6.3
 15.000
 min⁻¹

DIN 6357

h6

Bestell-Nr. Order no. Référence	HSK	DCONWS	TCDCON	LF	LSC	BD
C40.11.16	HSK-C 40	16	h6	50	17	40
C40.11.22	HSK-C 40	22	h6	60	19	40
C50.11.16	HSK-C 50	16	h6	60	17	40
C50.11.22	HSK-C 50	22	h6	60	19	50
C50.11.27	HSK-C 50	27	h6	60	21	50
C63.11.22	HSK-C 63	22	h6	50	19	48
C63.11.27	HSK-C 63	27	h6	60	21	60
C63.11.32	HSK-C 63	32	h6	60	24	78
C63.11.40	HSK-C 63	40	h6	60	27	89
C80.11.32	HSK-C 80	32	h6	48	24	78
C80.11.32.1	HSK-C 80	32	h6	60	24	78
C80.11.40	HSK-C 80	40	h6	60	27	89
C100.11.22	HSK-C 100	22	h6	50	19	48
C100.11.27	HSK-C 100	27	h6	50	21	60
C100.11.32	HSK-C 100	32	h6	50	24	78
C100.11.40	HSK-C 100	40	h6	60	27	89
C100.11.50	HSK-C 100	50	h6	70	30	120

5

DCONWS = 40 & 50 Für große Planfräser mit vier zusätzlichen Gewindebohrungen nach DIN 2079.
 For large diameter face mill cutters with four additional threaded holes according to DIN 2079.
 Pour fraises à surfacer à grands diamètres avec 4 taraudages supplémentaires suivant DIN 2079.

- Lieferumfang:** Mit Mitnehmersteinen, Kreuzschraube und Zylinderkopfschraube nach DIN 912 für Fräser mit innerer Kühlmittelzufuhr.
 Bei DCONWS = 60 nur mit vier Befestigungsschrauben nach DIN 912.
- Delivery:** With drivers, cross head retaining screw and cylinder head retaining screw for cutters with central coolant.
 For DCONWS = 60 only with four fixation screws according to DIN 912.
- Livraison:** Avec tenon d entraînement, vis cruciforme et vis à têtes cylindrique suivant DIN 912 pour les fraises avec arrosage central.
 Pour DCONWS = 60 est seulement avec quatre vis de fixation suivant DIN 912.





Verwendung:
Zur Aufnahme von Werkzeugen mit Zylinderschaft.

Application:
For mounting tools with straight shanks.

Application:
Pour le serrage d'outils avec queue cylindrique.

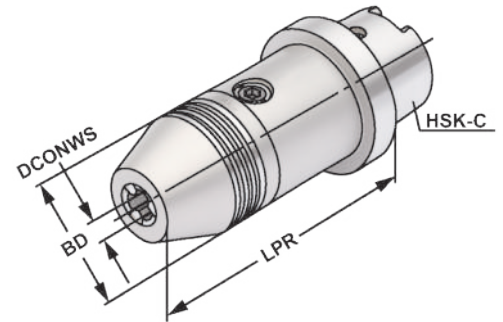

5

Bestell-Nr. Order no. Référence	HSK	DCONWS Spannbereich Capacity Capacité	LPR	BD	DRVS
C50.15.13	HSK-C 50	1,0 – 13	110	50	6
C50.15.16	HSK-C 50	2,5 – 16	115,5	50	6
C63.15.13	HSK-C 63	1,0 – 13	110	50	6
C63.15.16	HSK-C 63	2,5 – 16	115,5	50	6
C100.15.13	HSK-C 100	1,0 – 13	112,5	50	6
C100.15.16	HSK-C 100	2,5 – 16	118	50	6

Hinweis: Hohe Präzision und Rundlaufgenauigkeit von $\leq 0,03$ mm. Sichere Spannung des Werkzeuges durch mechanische Spannkraftverstärkung. Kein selbständiges Lösen der Spannung während der Bearbeitung bei Links- oder Rechtslauf, sowie bei Spindelstop. Spannen und Lösen mit Sechskantschlüssel.

Note: High precision and accurate concentricity of ≤ 0.03 mm. Secure gripping of the tool through mechanical amplification of the clamping force. No automatic slackening of the clamping force while machining with either clockwise or counter clockwise rotation or on spindle stop. Clamping and releasing effected by means of an Allen wrench.

Observation: Précision élevée et exactitude de circularité de $\leq 0,03$ mm. Serrage sûr de l'outil grâce à l'amplification de la force de serrage. Pas de desserrage intempestif en cours d'usinage lors de la rotation la gauche ou la droite, de même qu'en cas d'arrêt de la broche. Serrage et desserrage en utilisant un clé sur à fourche.

Lieferumfang: Ohne Spannschlüssel
Delivery: Without wrench
Livraison: Sans clé de serrage



Boring bar blanks
Barres d'alésage

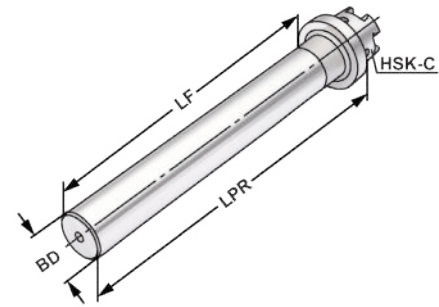

Verwendung:
Zur Herstellung von Sonderwerkzeugen.
Application:
For the manufacturing of special tools.
Application:
Pour la fabrication d'outils spéciaux.

ISO
12164Form
C

Bestell-Nr. Order no. Référence	HSK	LPR	BD
C25.17.32	HSK-C 25	110	32
C32.17.32	HSK-C 32	160	32
C40.17.50	HSK-C 40	160	43
C50.17.50	HSK-C 50	200	50
C63.17.63	HSK-C 63	250	63
C80.17.80	HSK-C 80	250	80
C100.17.93	HSK-C 100	250	93

5

Ausführung: Kegel und Bund gehärtet und geschliffen. Schaft weich zur weiteren Bearbeitung.
Version: Cone and flange hardened and grinded. Soft body for later processing.
Version: Cône et collerette durcis et rectifiés. Corps doux pour un usinage ultérieur.

Gewuchtete Ausführung

Balanced type Type équilibré



Bestell-Nr. Order no. Référence	Abmessung Size Dimension
---------------------------------------	--------------------------------

Wuchten auf G 2,5 von vorgewuchteten Kemmler-Werkzeugen

Balancing at G 2.5 of pre-balanced Kemmler-tools
Équilibrage sur G 2,5 d'outils Kemmler pré-équilibrés

W25

Ohne Wuchtprotokoll
Without balancing report
Sans protocole d'équilibrage

W25.2

Mit Wuchtprotokoll
With balancing report
Avec protocole d'équilibrage

Wuchten von nicht vorgewuchteten Werkzeugen
Balancing of unbalanced tools
Équilibrage d'outils non-équilibrés

W25.1

Ohne Wuchtprotokoll
Without balancing report
Sans protocole d'équilibrage



Verwendung:
Zur Abnahme von Werkzeugmaschinen gemäß ISO-Empfehlung R230 oder zur Überprüfung der Werkzeugspindel.

Application:
For the inspection of machine tools according to ISO recommendation R230 or for testing the tool spindle.

Application:
Pour l'inspection de machine-outils suite à la recommandation ISO R230 ou pour la vérification de la broche.

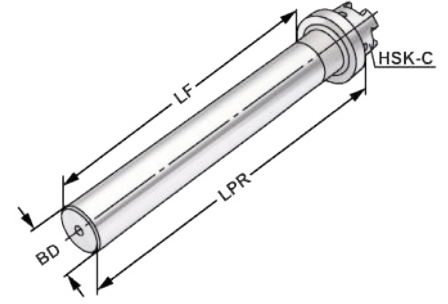

5

Bestell-Nr. Order no. Référence	HSK	BD	LPR	LF	Toleranz Tolerance Tolérance	max. Rundlaufabweichung max. concentricity deviation Faux-rond max.
C32.18.25	HSK-C 32	25	160	140	0,003	0,003
C40.18.25	HSK-C 40	25	160	140	0,003	0,003
C50.18.32	HSK-C 50	32	300	275	0,003	0,003
C63.18.40	HSK-C 63	40	300	275	0,003	0,003
C80.18.40	HSK-C 80	40	300	275	0,003	0,003
C100.18.50	HSK-C 100	50	300	275	0,003	0,003

Lieferumfang: Auslieferung mit Prüfprotokoll
Delivery: Delivery with test certificate
Livraison: Livraison avec rapport d essais

Holzkasten für Kontrolldorne

Wooden box for test arbors
Coffret en bois pour mandrins de contrôle



Verwendung:
Zur Aufbewahrung von Kontrolldornen.

Application:
For the storage of test arbors.

Application:
Pour la conservation de mandrins de contrôle.



Bestell-Nr. Order no. Référence	Abmessung Size Dimension	für Kegelgrößen for cones pour cônes
701.18	460 × 130 × 115	HSK 32 / 40 / 50 / 63 / 80 / 100



Verwendung:

Für einfaches und sicheres Klemmen von Werkzeugaufnahmen am Bund mittels Rollen zum Montieren und Demontieren von Schneidwerkzeugen. Reibschlüssig, daher selbstklemmend und ideal für HSK Formen E und F sowie Polygonschaft Aufnahmen.

Application:

For easy and reliable clamping of tool arbors at the collar using rollers to mount and remove cutting tools – friction lock is self-clamping and ideal for HSK forms E and F, and also polygon shank arbors.

Application:

Pour le serrage simple et sûr de porte-outils au niveau de la collerette à l'aide de galets pour le montage et le démontage d'outils de coupe – entraînement par friction, autoserrant.

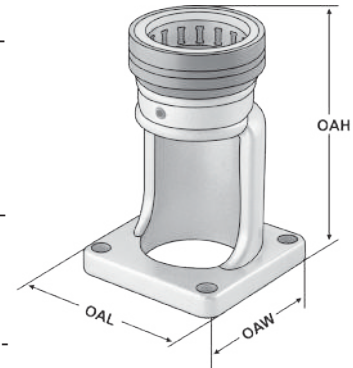

Bestell-Nr. Order no. Référence	Abmessung Size Dimension	OAL	OAW	OAH
707.1.032	HSK A32 - C32 - E32 - F32 - C3	110	110	165
707.1.040	HSK A40 - C40 - E40 - F40 - C4	110	110	165
707.1.050	HSK A50 - C50 - E50 - F50 - SK30 - C5	110	110	165
707.1.063	HSK A63 - C63 - E63 - F63 - BT40 - C6	110	110	172
707.1.080	HSK A80 - C80 - E80 - F80 - C8	160	160	215
707.1.100	HSK A100	160	160	219
707.1.BT30	BT30	110	110	165
707.1.SK40	SK40	110	110	172
707.1.SK50	SK50	160	160	219





Verwendung:
Zur Aufnahme von Werkzeugen mit Zylinderschaft nach DIN 1835 Form A+B+E und DIN 6535 Form HA+HB+HE

Application:
For mounting straight-shank tools acc. DIN 1835 form A+B+E and DIN 6535 form HA+HB+HE.

Application:
Pour le serrage d'outils avec queue cylindrique suivant DIN 1835 forme A+B+E et DIN 6535 forme HA+HB+HE.

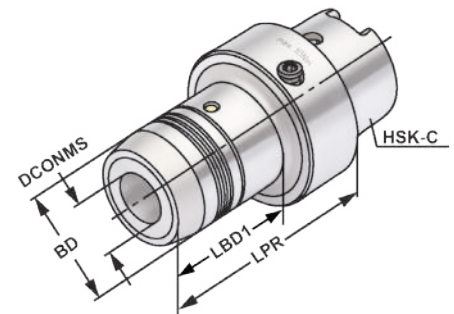

5

Bestell-Nr. Order no. Référence	HSK	DCONWS	LPR	BD	LSCX	ADJRGA	LBD1	DRVS	THID
C25.H06	HSK-C 25	6	60	26	37	10	38	5	M5x0,8
C25.H08	HSK-C 25	8	60	28	37	10	38	5	M5x0,8
C25.H10	HSK-C 25	10	65	30	42	10	38	5	M5x0,8
C32.H06	HSK-C 32	6	60	26	37	10	35	5	M5x0,8
C32.H08	HSK-C 32	8	60	28	37	10	36	5	M6x1
C32.H10	HSK-C 32	10	65	30	42	10	52	5	M8x1
C32.H12	HSK-C 32	12	70	32	47	10	-	5	M10x1
C32.H14	HSK-C 32	14	75	34	47	10	65	6	M10x1
C40.H06	HSK-C 40	6	60	26	37	10	35	5	M5x0,8
C40.H08	HSK-C 40	8	60	28	37	10	36	5	M6x1
C40.H10	HSK-C 40	10	65	30	42	10	38	5	M8x1
C40.H12	HSK-C 40	12	70	32	47	10	47	5	M10x1
C40.H14	HSK-C 40	14	80	34	47	10	49	5	M10x1
C40.H16	HSK-C 40	16	80	38	52	10	49	5	M12x1
C40.H18	HSK-C 40	18	80	40	52	10	49	5	M12x1
C40.H20	HSK-C 40	20	80	40	52	10	49	5	M12x1
C50.H06	HSK-C 50	6	60	26	37	10	33	5	M5x0,8
C50.H08	HSK-C 50	8	60	28	37	10	33	5	M6x1
C50.H10	HSK-C 50	10	65	30	42	10	39	5	M8x1
C50.H12	HSK-C 50	12	75	32	47	10	44	5	M10x1
C50.H14	HSK-C 50	14	75	34	47	10	46	5	M10x1
C50.H16	HSK-C 50	16	80	38	52	10	51	5	M12x1
C50.H18	HSK-C 50	18	80	40	52	10	52	5	M12x1
C50.H20	HSK-C 50	20	80	42	52	10	58	5	M12x1

LSCX = Einspannlänge, max.
LSCX = Clamping depth, max.
LSCX = Profondeur d'insertion, max.

ADJRGA = Verstellweg, max.
ADJRGA = Length adjustment range, max.
ADJRGA = Course de réglage, max.

Lieferumfang: Ohne Spannschlüssel
Delivery: Without wrench
Livraison: Sans clé de serrage

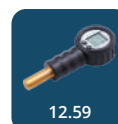
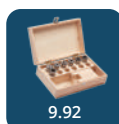



Verwendung:
Zur Aufnahme von Werkzeugen mit Zylinderschaft nach DIN 1835 Form A+B+E und DIN 6535 Form HA+HB+HE

Application:
For mounting straight-shank tools acc. DIN 1835 form A+B+E and DIN 6535 form HA+HB+HE.

Application:
Pour le serrage d'outils avec queue cylindrique suivant DIN 1835 forme A+B+E et DIN 6535 forme HA+HB+HE.

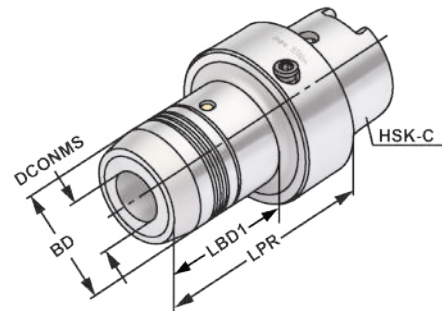

Bestell-Nr. Order no. Référence	HSK	DCONWS	LPR	BD	LSCX	ADJRGA	LBD1	DRVS	THID
C63.H06	HSK-C 63	6	60	26	37	10	29	5	M5x0,8
C63.H08	HSK-C 63	8	60	28	37	10	29	5	M6x1
C63.H10	HSK-C 63	10	65	30	42	10	35	5	M8x1
C63.H12	HSK-C 63	12	75	32	47	10	40	5	M10x1
C63.H14	HSK-C 63	14	75	34	47	10	42	5	M10x1
C63.H16	HSK-C 63	16	80	38	52	10	47	5	M12x1
C63.H18	HSK-C 63	18	80	40	52	10	48	5	M12x1
C63.H20	HSK-C 63	20	80	42	52	10	54	5	M12x1
C63.H25	HSK-C 63	25	95	50	58	10	51	6	M16x1
C63.H32	HSK-C 63	32	100	60	62	10	59	6	M16x1

LSCX = Einspannlänge, max. ADJRGA = Verstellweg, max.
LSCX = Clamping depth, max. ADJRGA = Length adjustment range, max.
LSCX = Profondeur d'insertion, max. ADJRGA = Course de réglage, max.

Lieferumfang: Ohne Spanschlüssel
Delivery: Without wrench
Livraison: Sans clé de serrage



Gewuchtete Ausführung



Balanced type
Type équilibré

Bestell-Nr. Order no. Référence	Abmessung Size Dimension
---------------------------------------	--------------------------------

Wuchten auf G 2,5 von vorgewuchteten
Kemmler-Werkzeugen

Balancing at G 2.5 of pre-balanced Kemmler-tools

Équilibrage sur G 2,5 d'outils Kemmler pré-équilibrés

W25 Ohne Wuchtprotokoll
Without balancing report
Sans protocole d'équilibrage

W25.2 Mit Wuchtprotokoll
With balancing report
Avec protocole d'équilibrage

Wuchten von nicht vorgewuchteten Werkzeugen
Balancing of unbalanced tools
Équilibrage d'outils non-équilibrés

W25.1 Ohne Wuchtprotokoll
Without balancing report
Sans protocole d'équilibrage

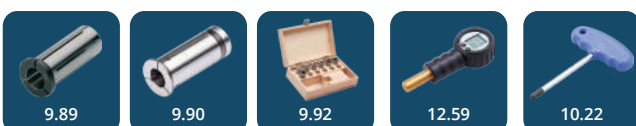



Shrink chucks 4,5° for mounting of solid carbide and HSS-tool shanks

Mandrins de frettage 4,5° pour le serrage de queues d'outils carbures de type HM et HSS



Verwendung:

Zur Aufnahme von Werkzeugen mit Zylinderschaft.

Application:

For mounting straight-shank tools.

Application:

Pour le serrage d'outils avec queue cylindrique.

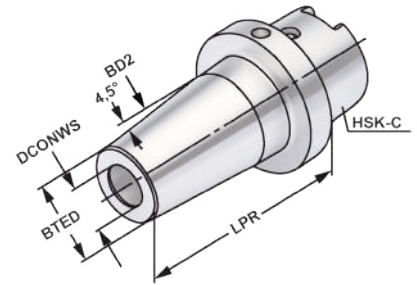

ISO 12164 Form C $\leq 3\mu\text{m}$ G2.5 25.000 min⁻¹ h6

5

Bestell-Nr. Order no. Référence	HSK	DCONWS	TDCON	LPR	BTED	BD2	LSCN	LSCX	ADJRGA	THID
C32.70.06	HSK-C 32	6	h6	65	21	27	15	20	5	M4
C32.70.08	HSK-C 32	8	h6	65	21	27	26	36	10	M6
C32.70.10	HSK-C 32	10	h6	65	24	32	32	42	10	M8x1
C32.70.12	HSK-C 32	12	h6	75	24	32	37	47	10	M10x1
C32.70.14	HSK-C 32	14	h6	80	27	34	37	47	10	M10x1
C32.70.16	HSK-C 32	16	h6	80	27	34	40	50	10	M12x1
C40.70.03	HSK-C 40	3	h4	70	11	15	9	10	-	-
C40.70.04	HSK-C 40	4	h4	70	14	22	15	20	5	M3
C40.70.05	HSK-C 40	5	h4	70	16	22	15	20	5	M4
C40.70.06	HSK-C 40	6	h6	70	21	27	26	36	10	M5x0,8
C40.70.08	HSK-C 40	8	h6	70	21	27	26	36	10	M6x1
C40.70.10	HSK-C 40	10	h6	70	24	32	32	42	10	M8x1
C40.70.12	HSK-C 40	12	h6	80	24	32	37	47	10	M10x1
C40.70.14	HSK-C 40	14	h6	80	27	34	37	47	10	M10x1
C40.70.16	HSK-C 40	16	h6	80	27	34	40	50	10	M12x1
C40.70.18	HSK-C 40	18	h6	80	33	42	40	50	10	M12x1
C40.70.20	HSK-C 40	20	h6	80	33	42	42	52	10	M16x1
C50.70.06	HSK-C 50	6	h6	70	21	27	26	36	10	M5x0,8
C50.70.08	HSK-C 50	8	h6	70	21	27	26	36	10	M6x1
C50.70.10	HSK-C 50	10	h6	75	24	32	32	42	10	M8x1
C50.70.12	HSK-C 50	12	h6	75	24	32	37	47	10	M10x1
C50.70.14	HSK-C 50	14	h6	80	27	34	37	47	10	M10x1
C50.70.16	HSK-C 50	16	h6	85	27	34	40	50	10	M12x1
C50.70.18	HSK-C 50	18	h6	85	33	42	40	50	10	M12x1
C50.70.20	HSK-C 50	20	h6	90	33	42	42	52	10	M16x1

LSCX = Einspannlänge, max.
LSCX = Clamping depth, max.
LSCX = Profondeur d'insertion, max.

ADJRGA = Verstellweg, max.
ADJRGA = Length adjustment range, max.
ADJRGA = Course de réglage, max.

Hinweis: Aufnahme für Induktiv-, Kontakt- und Heißluftschumpfergeräte geeignet.
Schafttoleranz bei Ø 3, 4 und 5 mm = h₄, bei Ø 6 - Ø 32 mm = h₆

Note: Toolholders suitable for induction-, contact- and hot air shrink units.
Ø 3, 4, 5 with h₄-tolerance and Ø 6 - Ø 32 with h₆-tolerance

Observation: Porte-outils convenables pour machines à fretter par induction, par contact, ou par air chaud.
Ø 3, 4, 5 avec h₄-tolerance et Ø 6 - Ø 32 avec h₆-tolerance



Shrink chucks 4,5° for mounting of solid carbide and HSS-tool shanks

Mandrins de frettage 4,5° pour le serrage de queues d'outils carbures de type HM et HSS



Verwendung:
Zur Aufnahme von Werkzeugen mit Zylinderschaft.

Application:
For mounting straight-shank tools.

Application:
Pour le serrage d'outils avec queue cylindrique.

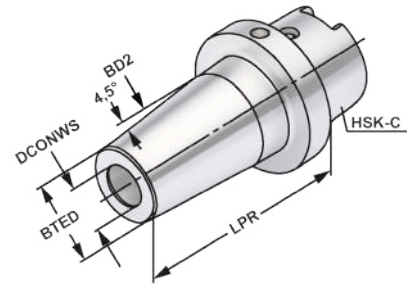

Bestell-Nr. Order no. Référence	HSK	DCONWS	TDCON	LPR	BTED	BD2	LSCN	LSCX	ADJRGA	THID
C63.70.06	HSK-C 63	6	h6	70	21	27	26	36	10	M5x0,8
C63.70.08	HSK-C 63	8	h6	70	21	27	26	36	10	M6x1
C63.70.10	HSK-C 63	10	h6	75	24	32	32	42	10	M8x1
C63.70.12	HSK-C 63	12	h6	80	24	32	37	47	10	M10x1
C63.70.14	HSK-C 63	14	h6	80	27	34	37	47	10	M10x1
C63.70.16	HSK-C 63	16	h6	85	27	34	40	50	10	M12x1
C63.70.18	HSK-C 63	18	h6	85	33	42	40	50	10	M12x1
C63.70.20	HSK-C 63	20	h6	90	33	42	42	52	10	M16x1
C63.70.25	HSK-C 63	25	h6	100	44	53	48	58	10	M16x1
C63.70.32	HSK-C 63	32	h6	110	44	53	51	61	10	M16x1



LSCX = Einspannlänge, max. ADJRGA = Verstellweg, max.
 LSCX = Clamping depth, max. ADJRGA = Length adjustment range, max.
 LSCX = Profondeur d'insertion, max. ADJRGA = Course de réglage, max.

Für Ø 3, 4 und 5 mm nur Hartmetallschäfte verwenden!
For Ø 3, 4 and 5 mm only solid carbide tool shanks must be used!
 Pour Ø 3, 4 et 5 mm il faut seulement utiliser de queues d'outils carbures de type HM!

- Hinweis:** Aufnahme für Induktiv-, Kontakt- und Heißluftschumpfgeräte geeignet. Schafttoleranz bei Ø 3, 4 und 5 mm = h₄, bei Ø 6 - Ø 32 mm = h₆
- Note:** Toolholders suitable for induction-, contact- and hot air shrink units. Ø 3, 4, 5 with h₄-tolerance and Ø 6 - Ø 32 with h₆-tolerance
- Observation:** Porte-outils convenables pour machines à fretter par induction, par contact, ou par air chaud. Ø 3, 4, 5 avec h₄-tolerance et Ø 6 - Ø 32 avec h₆-tolerance

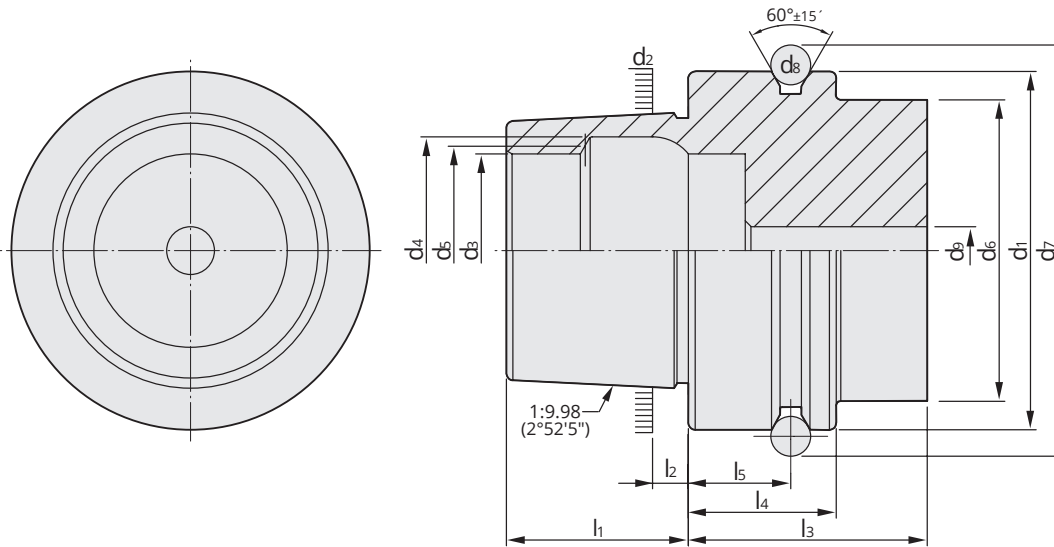

5

HSK	d ₁ h10	d ₂	d ₃ H10	d ₄ H11	d ₅	d ₆ max	d ₇ 0 -0,1	d ₈	d ₉ max	l ₁ 0 -0,2	l ₂	l ₃ min	l ₄ 0 -0,1	l ₅ ±0,1
25	25	19,006	14	16,4	15	20	28,5	3	3	13	2,5	20	10	4,5
32	32	24,007	17	20,5	19	26	37	4	4,2	16	3,2	35	20	16
40	40	30,007	21	25,5	23	34	45	4	5	20	4	35	20	16
50	50	38,009	26	32	29	42	59,3	7	6,8	25	5	42	26	18
63	63	48,010	34	40	37	53	72,3	7	8,4	32	6,3	42	26	18
80	80	60,012	42	50	46	68	88,8	7	10,2	40	8	42	26	18
100	100	75,013	53	63	58	88	109,75	7	12	50	10	45	29	20
125	125	95,016	67	80	73	111	134,75	7	14	63	12,5	45	29	20

Vorgewuchtet
Pre-balanced
 Pré-équilibré

G 6,3 15.000 min⁻¹
G 2,5 Feinwuchten gegen Aufpreis
G 2.5 Fine balancing at extra price
 G 2,5 Equilibrage fin contre un supplément

Werkstoff: Legierter Einsatzstahl mit einer Zugfestigkeit im Kern von min. 950 N / mm². Einsatzgehärtet HRC 60 ± 2 (HV 700 ± 50), Härtetiefe 0,8 mm ± 0,2 mm, brüniert und präzisionsgeschliffen.

Genauigkeit: Kegelwinkel – Toleranzqualität < AT 3 nach DIN 7187.

Material: *Alloyed case-hardened steel, tensile core strength of min. 950 N / mm². Case hardened HRC 60 ± 2 (HV 700 ± 50), hardening depth 0.8 mm ± 0.2 mm, black-finished and precisely grinded.*
Accuracy: *Quality of taper < AT 3 according to DIN 7187.*
Matière: Acier de cémentation allié. Résistance à la traction dans le noyau de min 950 N / mm². Cémentation à HRC 60 ± 2 (HV 700 ± 50), profondeur de cémentation 0,8 mm ± 0,2 mm, bruni et rectifié précisément.

Précision: Qualité du cône < AT 3 suivant DIN 7187.

Normative Verweise:

 DIN 69893-1:2011
 Kegel-Hohlschäfte mit Plananlage besteht aus:
 - Teil 1: Kegel-Hohlschäfte Form A und Form C;
 Maße und Ausführung

Normative references:

 DIN 69893-1:2011
 Hollow taper shanks with flange contact surface:
 - Part 1: Hollow taper shanks type A and type C;
 Dimensions and design

Références normatives:

 DIN 69893-1:2011
 Queues creuses coniques à surface de contact plane:
 - Partie 1: Queues creuses coniques type A et type C;
 Dimensions et conception



Index
Sommaire

 5.69	 5.70	 5.71	 5.72
 5.74	 5.75	 5.76	 5.77
 5.79			
			

Collet chucks for collets ISO 15488 (DIN 6499) ER-system
Mandrins à pinces pour pinces ISO 15488 (DIN 6499) système ER



Verwendung:
Zur Aufnahme von Werkzeugen mit Zylinderschaft in Spannzangen.

Application:
For mounting straight-shank tools in collets.

Application:
Destiné à recevoir les outils avec les queues de forme cylindrique dans les pinces de serrage.

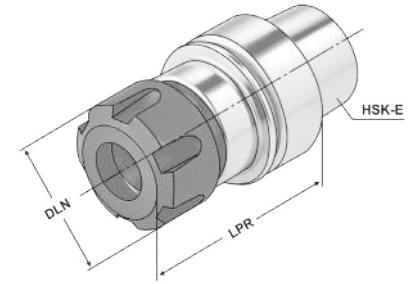

5

Bestell-Nr. Order no. Référence	HSK	DCONWS Spannbereich Capacity Capacité	Typ	LPR	DLN	THID
E25.02.10.M ¹	HSK-E 25	1 - 10	426E ER 16 Mini	52	22	M8
E25.02.10	HSK-E 25	1 - 10	426E ER 16	65	28	M10 x 1,5
E25.02.16.M ¹	HSK-E 25	2 - 16	430E ER 25 Mini	70	35	M8
E32.02.07.M ¹	HSK-E 32	1 - 7	4008E ER 11 Mini	60	16	M6x1
E32.02.10.M ¹	HSK-E 32	1 - 10	426E ER 16 Mini	65	22	M5
E32.02.13.M ¹	HSK-E 32	1 - 13	430E ER 25 Mini	75	28	M6
E32.02.16.M ¹	HSK-E 32	2 - 16	430E ER 25 Mini	85	35	M6
E32.02.20	HSK-E 32	2 - 20	470E ER 32	95	50	M16 x 2,0
E40.02.10.M ¹	HSK-E 40	1 - 10	426E ER 16 Mini	100	22	M8
E40.02.10	HSK-E 40	1 - 10	426E ER 16	65	32	M10 x 1,5
E40.02.13	HSK-E 40	1 - 13	428E ER 20	60	35	M12 x 1,75
E40.02.16	HSK-E 40	2 - 16	430E ER 25	75	42	M16 x 2,0
E40.02.20	HSK-E 40	2 - 20	470E ER 32	100	50	M16 x 2,0
E50.02.10	HSK-E 50	1 - 10	426E ER 16	80	28	M10 x 1,5
E50.02.16	HSK-E 50	2 - 16	430E ER 25	80	42	M16 x 2,0
E50.02.20	HSK-E 50	2 - 20	470E ER 32	85	50	M16 x 2,0
E50.02.26	HSK-E 50	3 - 26	472E ER 40	100	63	M16 x 2,0
E63.02.10.1	HSK-E 63	1 - 10	426E ER 16	100	28	M10 x 1,5
E63.02.16	HSK-E 63	2 - 16	430E ER 25	80	42	M16 x 2,0
E63.02.20	HSK-E 63	2 - 20	470E ER 32	90	50	M16 x 2,0
E63.02.26	HSK-E 63	3 - 26	472E ER 40	120	63	M16 x 2,0

¹ Minimutter
¹ Mini nut
¹ Écrous mini

Lieferumfang: Mit gewuchteter Spannmutter
Delivery: With balanced clamping nut
Livraison: Avec écrou de serrage équilibré

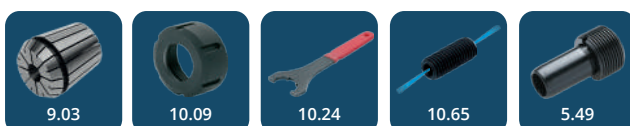

für Spannzangen ISO 15488 (DIN 6499) System ER

Precision collet chuck ER for collets ISO 15488 (DIN 6499) ER-system

Mandrin à pinces ER de précision pour pinces ISO 15488 (DIN 6499) système ER



Verwendung:
Zur Aufnahme von Werkzeugen mit Zylinderschaft in 3 µm-Spannzangen.

Application:
For mounting straight-shank tools in 3 µm-collets.

Application:
Pour le serrage d'outils avec queue cylindrique dans des pinces de serrage 3 µm.

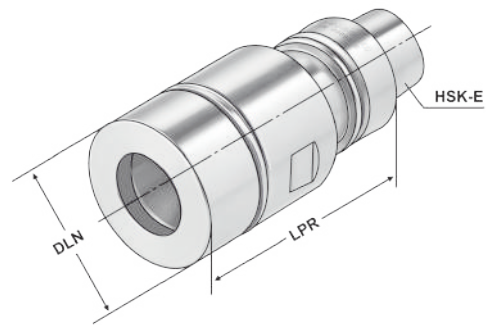

ISO 12164 Form E $\leq 3\mu\text{m}$ G2.5 25.000 min⁻¹ ISO 15488

13.04

Bestell-Nr. Order no. Référence	HSK	DCONWS Spannbereich Capacity Capacité	Typ	LPR	DLN	THID
E40.P2.20.070	HSK-E 40	2 - 20	470E ER 32	70	50	M16 x 2,0
E50.P2.20.070	HSK-E 50	2 - 20	470E ER 32	70	50	M16 x 2,0

5

Vorteile:

Exzellente Rundlaufgenauigkeit im System (Futter + Spannzange + Spannmutter)
Extreme Haltekräfte (erhöht die Haltekraft um mindestens 60 % im Vergleich zu Standard ER-Futter)
Glatte Spannmutter ohne Nuten für Hochgeschwindigkeitsbearbeitung

Advantages:

Excellent concentricity in the system (chuck + collet + clamping nut)
Extremely strong holding force (increases the holding power by at least 60% compared to standard ER chuck)
Plain clamping nut without grooves for high speed machining

Avantages:

Excellente précision de concentricité dans le système (mandrin + pince de serrage + écrou de serrage)
La force de maintien extrême (augmente la force de maintien d'au moins à 60% par rapport aux mandrins standards ER)
Écrou de serrage lisse sans rainures pour l'usinage à haute vitesse

Hinweis: Nur das Nennmaß DCONWS kann gespannt werden.
Note: *Only nominal size DCONWS can be clamped.*
Observation: Seulement la dimension nominale DCONWS peut être serrée.

Lieferumfang: Inklusive Präzisions-Spannmutter
Delivery: With *precision clamping nut*
Livraison: Avec écrou de serrage de précision



Collet chucks for collets | KPS-system
Mandrins à pinces pour pinces | Système KPS



Verwendung:
Zur Aufnahme von Werkzeugen mit Zylinderschaft in Spannzangen.
Für Anwendungen im HSC-Bereich und für hochpräzise Bearbeitungsergebnisse.

Application:
For mounting straight-shank tools in collets.
To use for high speed cutting and high precision milling.

Utilisation:
Pour la fixation d'outils à queue cylindrique dans les pinces de serrage. Pour l'UGV (Usinage à Grande Vitesse) et pour des résultats d'usinage de haute précision.

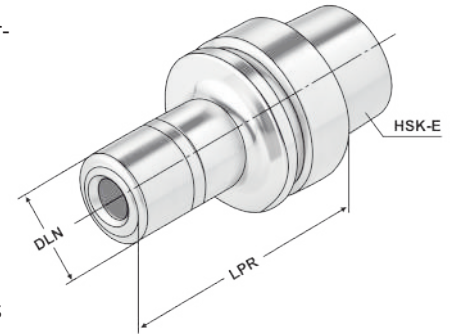

ISO 12164 Form E $\leq 3\mu\text{m}$ G2.5 30.000 min⁻¹ KPS

13.04

5

Bestell-Nr. Order no. Référence	HSK	DCONWS Spannbereich Capacity Capacité	Typ	LPR	DLN	THID
E40.03.10	HSK-E 40	1 – 10	490E KPS 10	75	27,5	M12 x 1,75
E40.03.16	HSK-E 40	4 – 16	496E KPS 16	75	40,0	M18 x 1,50
E63.03.10	HSK-E 63	1 – 10	490E KPS 10	105	27,5	M12 x 1,75
E63.03.16	HSK-E 63	4 – 16	496E KPS 16	120	40,0	M18 x 1,50

Lieferumfang: Mit gewuchteter Spannmutter
Delivery: With balanced clamping nut
Livraison: Avec écrou de serrage équilibré



End mill holders DIN 6359 for end mills DIN 1835-B

Porte-fraises DIN 6359 pour queues cylindriques DIN 1835-B

**Verwendung:**

Zum Spannen von zylindrischen Werkzeugschäften mit seitlicher Spannfläche nach DIN 1835 Form B (Weldon).

Application:

For mounting straight-shank tools with lateral flat according to DIN 1835 form B (Weldon).

Application:

Pour le serrage d'outils avec queue cylindrique et avec méplat de serrage latérale suivant DIN 1835 forme B (Weldon).

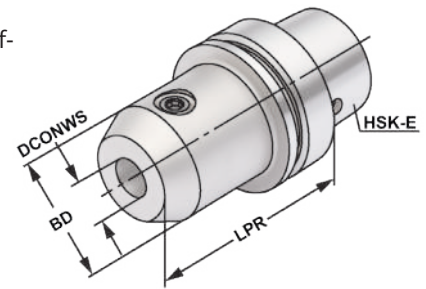

Bestell-Nr. Order no. Référence	HSK	DCONWS	TDCON	LPR	BD
E32.04.06	HSK-E 32	6	H4	60	25
E32.04.08	HSK-E 32	8	H4	60	28
E32.04.10	HSK-E 32	10	H4	65	35
E40.04.06	HSK-E 40	6	H4	60	25
E40.04.08	HSK-E 40	8	H4	60	28
E40.04.10	HSK-E 40	10	H4	60	35
E40.04.12	HSK-E 40	12	H4	70	42
E40.04.14	HSK-E 40	14	H4	75	44
E40.04.16	HSK-E 40	16	H4	75	48
E40.04.20	HSK-E 40	20	H4	75	52
E50.04.06	HSK-E 50	6	H4	65	25
E50.04.08	HSK-E 50	8	H4	65	28
E50.04.10	HSK-E 50	10	H4	65	35
E50.04.12	HSK-E 50	12	H4	80	42
E50.04.14	HSK-E 50	14	H4	80	44
E50.04.16	HSK-E 50	16	H4	80	48
E50.04.18	HSK-E 50	18	H4	80	50
E50.04.20	HSK-E 50	20	H4	80	52
E50.04.25	HSK-E 50	25	H4	102	65
E63.04.06	HSK-E 63	6	H4	65	25
E63.04.08	HSK-E 63	8	H4	65	28
E63.04.10	HSK-E 63	10	H4	65	35
E63.04.12	HSK-E 63	12	H4	80	42
E63.04.14	HSK-E 63	14	H4	80	44
E63.04.16	HSK-E 63	16	H4	80	48
E63.04.18	HSK-E 63	18	H4	80	50
E63.04.20	HSK-E 63	20	H4	80	52
E63.04.25	HSK-E 63	25	H4	110	65
E63.04.32	HSK-E 63	32	H4	110	72
E63.04.40	HSK-E 63	40	H4	120	63

Hinweis: Ab DCONWS = 25 mit zwei Spannschrauben
Note: From DCONWS = 25 on two clamping screws
Observation: A partir de DCONWS = 25 avec deux vis de serrage

Lieferumfang: Mit Spannschraube
Delivery: With clamping screw
Livraison: Avec vis de serrage

End mill holders DIN 6359 for end mills DIN 1835-E
 Porte-fraises DIN 6359 pour queues cylindriques DIN 1835-E



Verwendung:
 Zum Spannen von zylindrischen Werkzeugschäften mit geneigter Spannfläche nach DIN 1835 Form E (Whistle Notch).

Application:
 For mounting straight-shank tools and inclined flat according to DIN 1835 form E (Whistle Notch).

Application:
 Pour le serrage d'outils avec queue cylindrique et avec méplat incliné suivant DIN 1835 forme E (Whistle Notch).

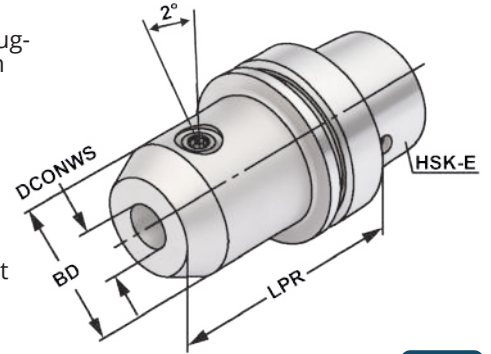

ISO 12164 Form E $\leq 3\mu\text{m}$ G6.3 15.000 min⁻¹ DIN 1835-E H4



5

Bestell-Nr. Order no. Référence	HSK	DCONWS	TDCON	LPR	BD
E32.05.06	HSK-E 32	6	H4	60	25
E32.05.08	HSK-E 32	8	H4	80	28
E32.05.10	HSK-E 32	10	H4	80	35
E40.05.06	HSK-E 40	6	H4	60	25
E40.05.08	HSK-E 40	8	H4	80	28
E40.05.10	HSK-E 40	10	H4	80	35
E40.05.12	HSK-E 40	12	H4	90	42
E40.05.14	HSK-E 40	14	H4	90	44
E40.05.16	HSK-E 40	16	H4	90	48
E50.05.06	HSK-E 50	6	H4	80	25
E50.05.08	HSK-E 50	8	H4	80	28
E50.05.10	HSK-E 50	10	H4	80	35
E50.05.12	HSK-E 50	12	H4	90	42
E50.05.14	HSK-E 50	14	H4	90	44
E50.05.16	HSK-E 50	16	H4	90	48
E50.05.18	HSK-E 50	18	H4	90	50
E50.05.20	HSK-E 50	20	H4	100	52
E63.05.06	HSK-E 63	6	H4	80	25
E63.05.08	HSK-E 63	8	H4	80	28
E63.05.10	HSK-E 63	10	H4	80	35
E63.05.12	HSK-E 63	12	H4	90	42
E63.05.14	HSK-E 63	14	H4	90	44
E63.05.16	HSK-E 63	16	H4	100	48
E63.05.18	HSK-E 63	18	H4	100	50
E63.05.20	HSK-E 63	20	H4	100	52
E63.05.25	HSK-E 63	25	H4	110	65
E63.05.32	HSK-E 63	32	H4	110	72

Hinweis: Ab DCONWS = 25 mit zwei Spannschrauben
Note: From DCONWS = 25 on two clamping screws
Observation: A partir de DCONWS = 25 avec deux vis de serrage

Lieferumfang: Mit Spannschraube und axialer Verstellechraube
Delivery: With clamping screw and axial adjustment bolt
Livraison: Avec vis de serrage et vis de butée axiale



mit vergrößerter Anlagefläche

Shell mill holders DIN 6357 with enlarged contact face
 Porte-fraises à trou lisse DIN 6357 avec face de contact élargie



Verwendung:
 Zur Aufnahme von Messerköpfen und Fräsern mit Quernut.
Application:
 For mounting milling cutters with transversal groove.
Application:
 Pour le serrage de fraises à rainure transversale.

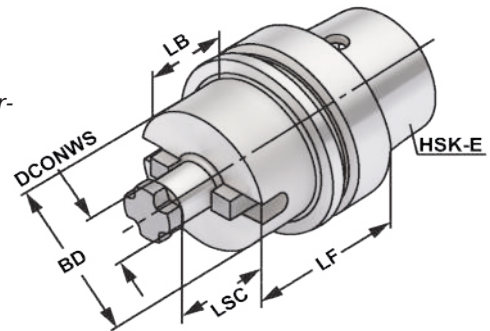

ISO 12164 Form E $\leq 5\mu\text{m}$ G6.3 15.000 min⁻¹ DIN 6357 h6

Bestell-Nr. Order no. Référence	HSK	DCONWS	TCDCON	LF	LSC	LB	BD
E32.11.16	HSK-E 32	16	h6	50	17	30	34
E40.11.16	HSK-E 40	16	h6	50	17	30	34
E40.11.22	HSK-E 40	22	h6	50	19	30	48
E40.11.27	HSK-E 40	27	h6	55	21	35	60
E50.11.16	HSK-E 50	16	h6	50	17	24	38
E50.11.22	HSK-E 50	22	h6	60	19	34	48
E50.11.27	HSK-E 50	27	h6	60	21	34	58
E50.11.32	HSK-E 50	32	h6	60	24	34	65
E63.11.16	HSK-E 63	16	h6	50	17	24	38
E63.11.22	HSK-E 63	22	h6	60	19	34	48
E63.11.27	HSK-E 63	27	h6	60	21	34	58
E63.11.32	HSK-E 63	32	h6	60	24	34	65
E63.11.40	HSK-E 63	40	h6	60	27	34	89

5

Lieferumfang: Mit Mitnehmersteinen und Kreuzschraube.
Delivery: With drivers and cross head retaining screw.
Livraison: Avec tenons et une vis cruciforme.

Gewuchtete Ausführung



Balanced type
 Type équilibré

Bestell-Nr. Order no. Référence	Abmessung Size Dimension
---------------------------------------	--------------------------------

Wuchten auf G 2,5 von vorgewuchteten Kemmler-Werkzeugen
 Balancing at G 2.5 of pre-balanced Kemmler-tools
 Équilibrage sur G 2,5 d'outils Kemmler pré-équilibrés
 W25

Ohne Wuchtprotokoll
 Without balancing report
 Sans protocole d'équilibrage

W25.2 **Mit Wuchtprotokoll**
 With balancing report
 Avec protocole d'équilibrage

Wuchten von nicht vorgewuchteten Werkzeugen
 Balancing of unbalanced tools
 Équilibrage d'outils non-équilibrés

W25.1 **Ohne Wuchtprotokoll**
 Without balancing report
 Sans protocole d'équilibrage

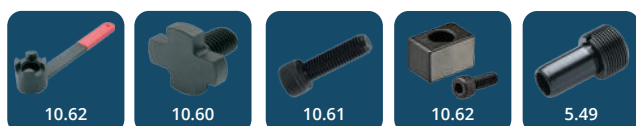

CNC-Drill chucks for clockwise and counter clockwise rotation
Mandrins de perçage CNC pour rotation gauche-droite



Verwendung:
Zur Aufnahme von Werkzeugen mit Zylinderschaft.

Application:
For mounting tools with straight shanks.

Application:
Pour le serrage d'outils avec queue cylindrique.

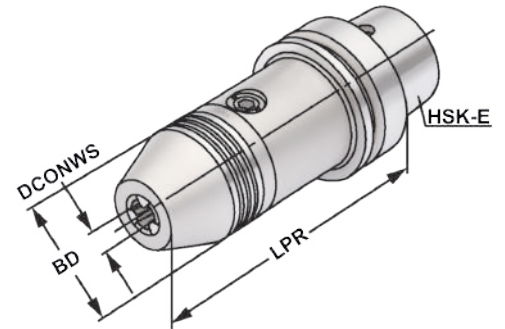

5

Bestell-Nr. Order no. Référence	HSK	DCONWS Spannbereich Capacity Capacité	LPR	BD	DRVS
E25.15.08	HSK-E 25	0 – 8	70,0	36	4
E32.15.08	HSK-E 32	0 – 8	75,0	36	4
E40.15.08	HSK-E 40	0 – 8	80,0	36	4
E40.15.13	HSK-E 40	1,0 – 13	119,0	50	6
E40.15.16	HSK-E 40	2,5 – 16	124,5	50	6
E50.15.08	HSK-E 50	0 – 8	80	36	4
E50.15.13	HSK-E 50	1,0 – 13	121,0	50	6
E50.15.16	HSK-E 50	2,5 – 16	126,5	50	6
E63.15.13	HSK-E 63	1,0 – 13	123,5	50	6
E63.15.16	HSK-E 63	2,5 – 16	129,0	50	6

Hinweis: Hohe Präzision und Rundlaufgenauigkeit von $\leq 0,03$ mm. Sichere Spannung des Werkzeuges durch mechanische Spannkraftverstärkung. Kein selbständiges Lösen der Spannung während der Bearbeitung bei Links- oder Rechtslauf, sowie bei Spindelstop. Spannen und Lösen mit Sechskantschlüssel.

Note: High precision and accurate concentricity of ≤ 0.03 mm. Secure gripping of the tool through mechanical amplification of the clamping force. No automatic slackening of the clamping force while machining with either clockwise or counter clockwise rotation or on spindle stop. Clamping and releasing effected by means of an Allen wrench.

Observation: Précision élevée et exactitude de circularité de $\leq 0,03$ mm. Serrage sûr de l'outil grâce à l'amplification de la force de serrage. Pas de desserrage intempestif en cours d'usinage lors de la rotation la gauche ou la droite, de même qu'en cas d'arrêt de la broche. Serrage et desserrage en utilisant un clé sur à fourche.

Lieferumfang: Ohne Spannschlüssel
Delivery: Without wrench
Livraison: Sans clé de serrage



Boring bar blanks
Barres d'alésage

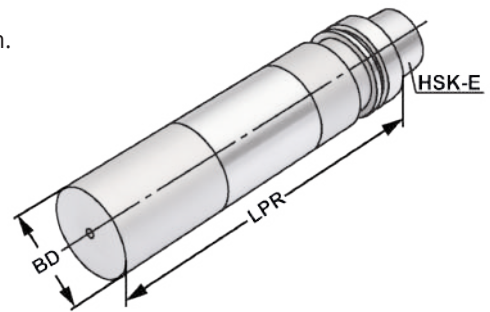

Verwendung:
Zur Herstellung von Sonderwerkzeugen.
Application:
For the manufacturing of special tools.
Application:
Pour la fabrication d'outils spéciaux.

ISO
12164Form
E

Bestell-Nr.
Order no.
Référence

HSK

LPR

BD

E25.17.30

HSK-E 25

40

30,0

E32.17.32

HSK-E 32

100

32,5

E40.17.40

HSK-E 40

125

40,5

E50.17.50

HSK-E 50

125

50,5

E63.17.63

HSK-E 63

250

63,5

Ausführung:
Version:
Version:

Kegel und Bund gehärtet und geschliffen. Schaft weich zur weiteren Bearbeitung.
Cone and flange hardened and grinded. Soft body for later processing.
Cône et collerette durcis et rectifiés. Corps doux pour un usinage ultérieur.

5





Hydraulic expansion chucks Mandrins expansibles hydrauliques



Verwendung:
Zur Aufnahme von Werkzeugen mit Zylinderschaft nach DIN 1835 Form A+B+E und DIN 6535 Form HA+HB+HE (größer Ø 20 mm nur mit Reduzierung).

Application:
For mounting straight-shank tools acc. DIN 1835 form A+B+E and DIN 6535 form HA+HB+HE (larger than dia. 20 mm only with reduction sleeve).

Application:
Pour le serrage d'outils avec queue cylindrique suivant DIN 1835 forme A+B+E et DIN 6535 forme HA+HB+HE.

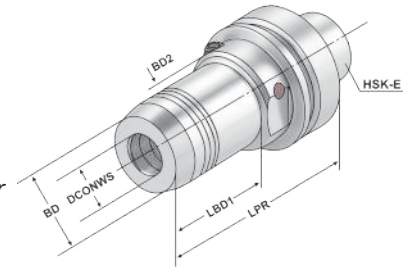

ISO 12164 Form E $\leq 3\mu\text{m}$ G6.3 15.000 min⁻¹

13.04

5

14.04

Bestell-Nr. Order no. Référence	HSK	DCONWS	LPR	BD	BD2	LSCX	ADJRG	LBD1	DRVS	THID
E25.H06	HSK-E 25	6	70	26	20	37	10	38	5	M5
E25.H08	HSK-E 25	8	80	28	20	37	10	-	5	M5
E25.H10	HSK-E 25	10	85	30	20	42	10	-	5	M6
E25.H12	HSK-E 25	12	90	32	20	47	10	-	5	M6
E32.H06	HSK-E 32	6	80	26	26	37	10	60	5	M5
E32.H08	HSK-E 32	8	80	28	26	37	10	-	5	M6
E32.H10	HSK-E 32	10	85	30	26	42	10	-	5	M6
E32.H12	HSK-E 32	12	90	32	26	47	10	-	5	M6
E40.H06	HSK-E 40	6	80	26	34	37	10	35	5	M5
E40.H08	HSK-E 40	8	80	28	34	37	10	36	5	M6
E40.H10	HSK-E 40	10	85	30	34	42	10	41	5	M8x1
E40.H12	HSK-E 40	12	90	32	34	47	10	47	5	M8x1
E40.H14	HSK-E 40	14	90	34	34	47	10	70	5	M10x1
E40.H16	HSK-E 40	16	100	38	34	52	10	-	5	M10x1
E40.H20	HSK-E 40	20	100	42	50	52	10	-	5	M12x1
E50.H06	HSK-E 50	6	80	26	42	37	10	54	5	M5
E50.H08	HSK-E 50	8	80	28	42	37	10	54	5	M6
E50.H10	HSK-E 50	10	85	30	42	42	10	59	5	M8x1
E50.H12	HSK-E 50	12	90	32	42	47	10	64	5	M8x1
E50.H14	HSK-E 50	14	90	34	42	47	10	64	5	M10x1
E50.H16	HSK-E 50	16	95	38	42	52	10	69	5	M10x1
E50.H18	HSK-E 50	18	95	40	42	52	10	69	5	M10x1
E50.H20	HSK-E 50	20	100	42	42	52	10	74	5	M10x1

LSCX = Einspannlänge, max.
LSCX = Clamping depth, max.
LSCX = Profondeur d'insertion, max.

ADJRG = Verstellweg, max.
ADJRG = Length adjustment range, max.
ADJRG = Course de réglage, max.

Lieferumfang: Ohne Spannschlüssel
Delivery: Without wrench
Livraison: Sans clé de serrage



Hydraulic expansion chucks
Mandrins expansibles hydrauliques



Verwendung:
Zur Aufnahme von Werkzeugen mit Zylinderschaft nach DIN 1835 Form A+B+E und DIN 6535 Form HA+HB+HE (größer Ø 20 mm nur mit Reduzierung).

Application:
For mounting straight-shank tools acc. DIN 1835 form A+B+E and DIN 6535 form HA+HB+HE (larger than dia. 20 mm only with reduction sleeve).

Application:
Pour le serrage d'outils avec queue cylindrique suivant DIN 1835 forme A+B+E et DIN 6535 forme HA+HB+HE.

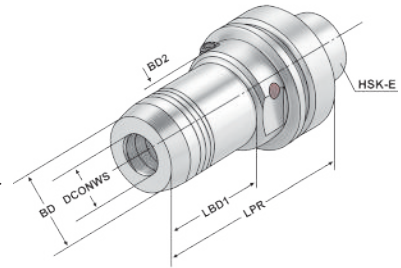

ISO
12164

Form
E

≤ 3µm

G6.3
15.000
min⁻¹

13.04

Bestell-Nr. Order no. Référence	HSK	DCONWS	LPR	BD	BD2	LSCX	ADJRGA	LBD1	DRVS	THID
E63.H06	HSK-E 63	6	80	26	50	37	10	33	5	M5
E63.H08	HSK-E 63	8	80	28	50	37	10	33,5	5	M6
E63.H10	HSK-E 63	10	85	30	50	42	10	39	5	M8x1
E63.H12	HSK-E 63	12	90	32	50	47	10	44,5	5	M10x1
E63.H14	HSK-E 63	14	90	34	50	47	10	46	5	M12x1
E63.H16	HSK-E 63	16	95	38	50	52	10	51,5	5	M12x1
E63.H18	HSK-E 63	18	95	40	50	52	10	52	5	M12x1
E63.H20	HSK-E 63	20	100	42	50	52	10	58	5	M12x1
E63.H25	HSK-E 63	25	120	50	50	58	10	59	5	M12x1
E63.H32	HSK-E 63	32	125	60	60	62	10	59	5	M12x1

5

LSCX = Einspannlänge, max. ADJRGA = Verstellweg, max.
LSCX = Clamping depth, max. ADJRGA = Length adjustment range, max.
LSCX = Profondeur d'insertion, max. ADJRGA = Course de réglage, max.

Lieferumfang: Ohne Spannschlüssel
Delivery: Without wrench
Livraison: Sans clé de serrage



Spannkraft-Prüfgerät für Hydrodehnspannfutter - Seite 12.59
Clamping force proofing instrument for hydraulic chucks - page 12.59
Appareil de contrôle des forces de serrage pour mandrin expansibles hydrauliques - page 12.59





zum Spannen von HM und HSS Werkzeugschäften

Shrink chucks 4,5° for mounting of solid carbide and HSS-tool shanks

Mandrins de frettage 4,5° pour le serrage de queues d'outils carbures de type HM et HSS



Verwendung:
Zur Aufnahme von Werkzeugen mit Zylinderschaft.

Application:
For mounting straight-shank tools.

Application:
Pour le serrage d'outils avec queue cylindrique.

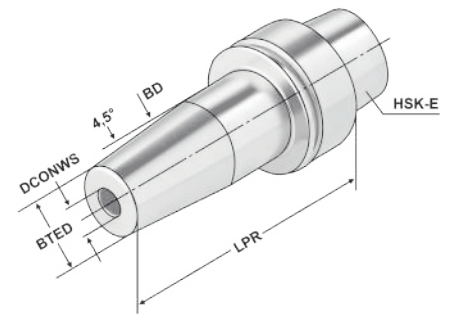

ISO 12164	Form E	≤ 3µm	G2.5 25.000 min ⁻¹	h6
-----------	--------	-------	-------------------------------	----

5

Bestell-Nr. Order no. Référence	HSK	DCONWS	TDCON	LPR	BTED	BD	LSCN	LSCX	ADJRGA	THID
E25.70.03	HSK-E 25	3	h4	40	11	15	5	10	-	-
E25.70.04	HSK-E 25	4	h4	40	16	22	12	20	-	-
E25.70.05	HSK-E 25	5	h4	50	16	22	15	20	-	-
E25.70.06	HSK-E 25	6	h6	50	21	26	18	36	-	-
E25.70.08	HSK-E 25	8	h6	50	21	26	24	36	-	-
E25.70.10	HSK-E 25	10	h6	50	21	26	30	42	-	-
E25.70.12	HSK-E 25	12	h6	50	24	26	34	47	-	-
E32.70.03	HSK-E 32	3	h4	70	11	15	9	10	-	-
E32.70.04	HSK-E 32	4	h4	70	16	22	15	20	5	M3
E32.70.05	HSK-E 32	5	h4	70	16	22	15	20	5	M4
E32.70.06	HSK-E 32	6	h6	70	21	26	26	36	10	M5
E32.70.08	HSK-E 32	8	h6	70	21	26	26	36	10	M6
E32.70.10	HSK-E 32	10	h6	70	24	26	32	42	10	M8x1
E32.70.12	HSK-E 32	12	h6	85	24	26	37	47	10	M10x1
E40.70.03	HSK-E 40	3	h4	80	9	18	10	18	-	-
E40.70.04	HSK-E 40	4	h4	80	10	22	10	20	5	-
E40.70.05	HSK-E 40	5	h4	80	16	22	10	20	5	-
E40.70.06	HSK-E 40	6	h6	80	21	27	26	36	10	M5
E40.70.08	HSK-E 40	8	h6	80	21	27	26	36	10	M6
E40.70.10	HSK-E 40	10	h6	80	24	32	32	42	10	M8x1
E40.70.12	HSK-E 40	12	h6	90	24	32	37	47	10	M8x1
E40.70.14	HSK-E 40	14	h6	90	27	34	37	47	10	M10x1
E40.70.16	HSK-E 40	16	h6	90	27	34	40	50	10	M12x1

LSCX = Einspannlänge, max. ADJRGA = Verstellweg, max.
 LSCX = Clamping depth, max. ADJRGA = Length adjustment range, max.
 LSCX = Profondeur d'insertion, max. ADJRGA = Course de réglage, max.

Hinweis: Aufnahme für Induktiv-, Kontakt- und Heißluftschrimpferäte geeignet. Schafttoleranz bei Ø 3, 4 und 5 mm = h₄, bei Ø 6 - Ø 32 mm = h₆

Note: Toolholders suitable for induction-, contact- and hot air shrink units. Ø 3, 4, 5 with h₄-tolerance and Ø 6 - Ø 32 with h₆-tolerance

Observation: Porte-outils convenables pour machines à fretter par induction, par contact, ou par air chaud. Ø 3, 4, 5 avec h₄-tolerance et Ø 6 - Ø 32 avec h₆-tolerance





zum Spannen von HM und HSS Werkzeugschäften

Shrink chucks 4,5° for mounting of solid carbide and HSS-tool shanks

Mandrins de frettage 4,5° pour le serrage de queues d'outils carbures de type HM et HSS



Verwendung:
Zur Aufnahme von Werkzeugen mit Zylinderschaft.

Application:
For mounting straight-shank tools.

Application:
Pour le serrage d'outils avec queue cylindrique.

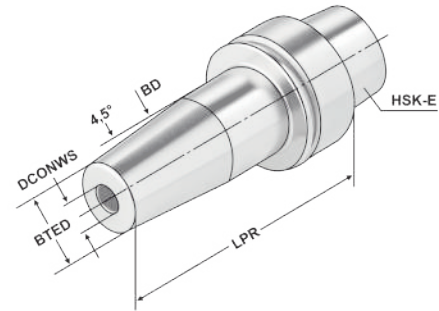

ISO 12164 Form E $\leq 3\mu\text{m}$ G2.5 25.000 min⁻¹ h6

Bestell-Nr. Order no. Référence	HSK	DCONWS	TDCON	LPR	BTED	BD	LSCN	LSCX	ADJRGA	THID
E40.70.06.1	HSK-E 40	6	h6	130	21	27	26	36	10	M5
E40.70.08.1	HSK-E 40	8	h6	130	21	27	26	36	10	M6
E40.70.10.1	HSK-E 40	10	h6	130	24	32	32	42	10	M8x1
E40.70.12.1	HSK-E 40	12	h6	130	24	32	37	47	10	M10x1
E40.70.14.1	HSK-E 40	14	h6	130	27	34	37	47	10	M10x1
E40.70.16.1	HSK-E 40	16	h6	130	27	34	40	50	10	M12x1
E50.70.03	HSK-E 50	3	h4	80	11	15	9	10	-	-
E50.70.04	HSK-E 50	4	h4	80	16	22	15	20	5	M3
E50.70.05	HSK-E 50	5	h4	80	16	22	15	20	5	M4
E50.70.06	HSK-E 50	6	h6	80	21	27	26	36	10	M5
E50.70.08	HSK-E 50	8	h6	80	21	27	26	36	10	M6
E50.70.10	HSK-E 50	10	h6	85	24	32	32	42	10	M8x1
E50.70.12	HSK-E 50	12	h6	90	24	32	37	47	10	M10x1
E50.70.14	HSK-E 50	14	h6	90	27	34	37	47	10	M10x1
E50.70.16	HSK-E 50	16	h6	95	27	34	40	50	10	M12x1
E50.70.18	HSK-E 50	18	h6	95	33	42	40	50	10	M12x1
E50.70.20	HSK-E 50	20	h6	100	33	42	42	52	10	M16x1
E50.70.03.1	HSK-E 50	3	h4	120	11	21	9	10	-	-
E50.70.04.1	HSK-E 50	4	h4	120	14	21	15	20	5	M3
E50.70.05.1	HSK-E 50	5	h4	120	16	24	15	20	5	M4
E50.70.06.1	HSK-E 50	6	h6	120	21	27	26	36	10	M5
E50.70.08.1	HSK-E 50	8	h6	120	21	27	26	36	10	M6
E50.70.10.1	HSK-E 50	10	h6	120	24	32	32	42	10	M8x1
E50.70.12.1	HSK-E 50	12	h6	120	24	32	37	47	10	M10x1
E50.70.14.1	HSK-E 50	14	h6	120	27	34	37	47	10	M10x1
E50.70.16.1	HSK-E 50	16	h6	120	27	34	40	50	10	M12x1
E50.70.18.1	HSK-E 50	18	h6	120	33	42	40	50	10	M12x1
E50.70.20.1	HSK-E 50	20	h6	120	33	42	42	52	10	M16x1

LSCX = Einspannlänge, max. ADJRGA = Verstellweg, max.
 LSCX = Clamping depth, max. ADJRGA = Length adjustment range, max.
 LSCX = Profondeur d'insertion, max. ADJRGA = Course de réglage, max.

Für Ø 3, 4 und 5 mm nur Hartmetallschäfte verwenden!

For Ø 3, 4 and 5 mm only solid carbide tool shanks must be used!

Pour Ø 3, 4 et 5 mm il faut seulement utiliser de queues d'outils carbures de type HM!

Hinweis: Aufnahme für Induktiv-, Kontakt- und Heißluftschumpfgeräte geeignet.
 Schafttoleranz bei Ø 3, 4 und 5 mm = h₄, bei Ø 6 - Ø 32 mm = h₆

Note: Toolholders suitable for induction-, contact- and hot air shrink units.
 Ø 3, 4, 5 with h₄-tolerance and Ø 6 - Ø 32 with h₆-tolerance

Observation: Porte-outils convenables pour machines à fretter par induction,
 par contact, ou par air chaud.
 Ø 3, 4, 5 avec h₄-tolerance et Ø 6 - Ø 32 avec h₆-tolerance





zum Spannen von HM und HSS Werkzeugschäften

Shrink chucks 4,5° for mounting of solid carbide and HSS-tool shanks

Mandrins de frettage 4,5° pour le serrage de queues d'outils carbures de type HM et HSS



Verwendung:

Zur Aufnahme von Werkzeugen mit Zylinderschaft.

Application:

For mounting straight-shank tools.

Application:

Pour le serrage d'outils avec queue cylindrique.

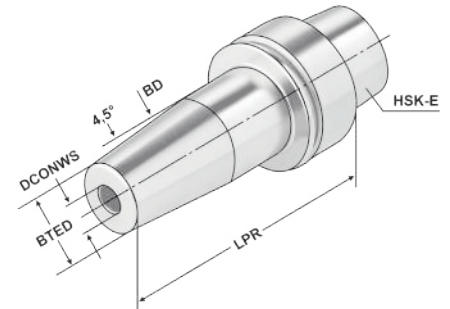

ISO 12164 Form E $\leq 3\mu\text{m}$ G2.5 25.000 min⁻¹ h6

5

Bestell-Nr. Order no. Référence	HSK	DCONWS	TDCON	LPR	BTED	BD	LSCN	LSCX	ADJRGA	THID
E50.70.03.2	HSK-E 50	3	h4	160	11	21	9	10	-	-
E50.70.04.2	HSK-E 50	4	h4	160	14	21	15	20	5	M3
E50.70.05.2	HSK-E 50	5	h4	160	16	24	15	20	5	M4
E50.70.06.2	HSK-E 50	6	h6	160	21	27	26	36	10	M5
E50.70.08.2	HSK-E 50	8	h6	160	21	27	26	36	10	M6
E50.70.10.2	HSK-E 50	10	h6	160	24	32	31	41	10	M8x1
E50.70.12.2	HSK-E 50	12	h6	160	24	32	37	47	10	M10x1
E50.70.14.2	HSK-E 50	14	h6	160	27	34	37	47	10	M10x1
E50.70.16.2	HSK-E 50	16	h6	160	27	34	40	50	10	M12x1
E50.70.18.2	HSK-E 50	18	h6	160	33	42	40	50	10	M12x1
E50.70.20.2	HSK-E 50	20	h6	160	33	42	42	52	10	M16x1
E63.70.03	HSK-E 63	3	h4	80	11	15	9	10	-	-
E63.70.04	HSK-E 63	4	h4	80	14	22	15	20	5	M3
E63.70.05	HSK-E 63	5	h4	80	16	22	15	20	5	M4
E63.70.06	HSK-E 63	6	h6	80	21	27	26	36	10	M5
E63.70.08	HSK-E 63	8	h6	80	21	27	26	36	10	M6
E63.70.10	HSK-E 63	10	h6	85	24	32	31	41	10	M8x1
E63.70.12	HSK-E 63	12	h6	90	24	32	37	47	10	M10x1
E63.70.14	HSK-E 63	14	h6	90	27	34	37	47	10	M10x1
E63.70.16	HSK-E 63	16	h6	95	27	34	40	50	10	M12x1
E63.70.18	HSK-E 63	18	h6	95	33	42	40	50	10	M12x1
E63.70.20	HSK-E 63	20	h6	100	33	42	42	52	10	M16x1
E63.70.25	HSK-E 63	25	h6	115	44	53	48	58	10	M16x1
E63.70.32	HSK-E 63	32	h6	120	44	53	52	62	10	M20x1

LSCX = Einspannlänge, max.
LSCX = Clamping depth, max.
LSCX = Profondeur d'insertion, max.

ADJRGA = Verstellweg, max.
ADJRGA = Length adjustment range, max.
ADJRGA = Course de réglage, max.

Für Ø 3, 4 und 5 mm nur Hartmetallschäfte verwenden!

For Ø 3, 4 and 5 mm only solid carbide tool shanks must be used!

Pour Ø 3, 4 et 5 mm il faut seulement utiliser de queues d'outils carbures de type HM!

Hinweis: Aufnahme für Induktiv-, Kontakt- und Heißluftschumpfgeräte geeignet. Schafttoleranz bei Ø 3, 4 und 5 mm = h₄, bei Ø 6 - Ø 32 mm = h₆

Note: Toolholders suitable for induction-, contact- and hot air shrink units. Ø 3, 4, 5 with h₄-tolerance and Ø 6 - Ø 32 with h₆-tolerance

Observation: Porte-outils convenables pour machines à fretter par induction, par contact, ou par air chaud. Ø 3, 4, 5 avec h₄-tolerance et Ø 6 - Ø 32 avec h₆-tolerance

zum Spannen von HM und HSS Werkzeugschäften

Shrink chucks 4,5° for mounting of solid carbide and HSS-tool shanks

Mandrins de frettage 4,5° pour le serrage de queues d'outils carbures de type HM et HSS



Verwendung:
Zur Aufnahme von Werkzeugen mit Zylinderschaft.

Application:
For mounting straight-shank tools.

Application:
Pour le serrage d'outils avec queue cylindrique.

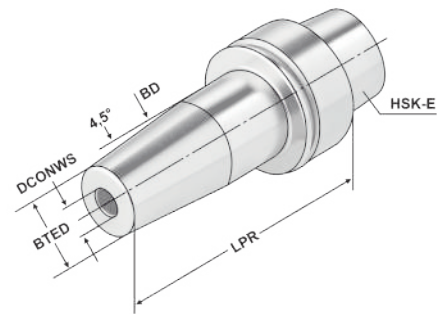

ISO 12164 Form E $\leq 3\mu\text{m}$ G2.5 25.000 min⁻¹ h6

Bestell-Nr. Order no. Référence	HSK	DCONWS	TDCON	LPR	BTED	BD	LSCN	LSCX	ADJRGA	THID
E63.70.04.1	HSK-E 63	4	h4	120	14	21	15	20	5	M3
E63.70.06.1	HSK-E 63	6	h6	120	21	27	26	36	10	M5
E63.70.08.1	HSK-E 63	8	h6	120	21	27	26	36	10	M6
E63.70.10.1	HSK-E 63	10	h6	120	24	32	31	41	10	M8x1
E63.70.12.1	HSK-E 63	12	h6	120	24	32	37	47	10	M10x1
E63.70.16.1	HSK-E 63	16	h6	120	27	34	40	50	10	M12x1
E63.70.03.2	HSK-E 63	3	h4	160	11	21	9	10	-	-
E63.70.04.2	HSK-E 63	4	h4	160	14	21	5	20	5	M3
E63.70.06.2	HSK-E 63	6	h6	160	21	27	26	36	10	M5
E63.70.08.2	HSK-E 63	8	h6	160	21	27	26	36	10	M6
E63.70.10.2	HSK-E 63	10	h6	160	24	32	31	41	10	M8x1
E63.70.12.2	HSK-E 63	12	h6	160	24	32	37	47	10	M10x1
E63.70.16.2	HSK-E 63	16	h6	160	27	34	40	50	10	M12x1
E63.70.18.2	HSK-E 63	18	h6	160	33	42	40	50	10	M12x1
E63.70.20.2	HSK-E 63	20	h6	160	33	42	42	52	10	M16x1
E63.70.25.2	HSK-E 63	25	h6	160	44	42	48	58	10	M16x1

5

LSCX = Einspannlänge, max. ADJRGA = Verstellweg, max.
LSCX = Clamping depth, max. ADJRGA = Length adjustment range, max.
LSCX = Profondeur d'insertion, max. ADJRGA = Course de réglage, max.

Für Ø 3, 4 und 5 mm nur Hartmetallschäfte verwenden!
For Ø 3, 4 and 5 mm only solid carbide tool shanks must be used!
Pour Ø 3, 4 et 5 mm il faut seulement utiliser de queues d'outils carbures de type HM!

Hinweis: Aufnahme für Induktiv-, Kontakt- und Heißluftschumpfergeräte geeignet.
Schafttoleranz bei Ø 3, 4 und 5 mm = h₄, bei Ø 6 – Ø 32 mm = h₆

Note: Toolholders suitable for induction-, contact- and hot air shrink units.
Ø 3, 4, 5 with h₄-tolerance and Ø 6 – Ø 32 with h₆-tolerance

Observation: Porte-outils convenables pour machines à fretter par induction, par contact, ou par air chaud.
Ø 3, 4, 5 avec h₄-tolerance et Ø 6 – Ø 32 avec h₆-tolerance

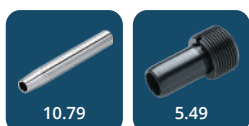

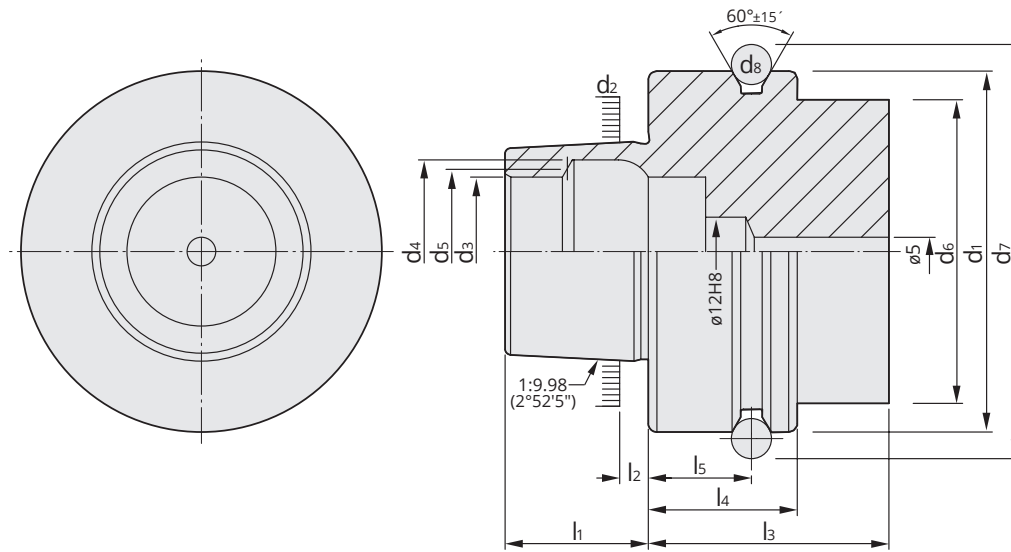
5

HSK	d ₁ h10	d ₂	d ₃ H10	d ₄ H11	d ₅	d ₆ max	d ₇ 0 -0,1	d ₈	l ₁ 0 -0,2	l ₂	l ₃	l ₄ 0 -0,1	l ₅ ±0,1
50	50	30,007	21	25,5	23	42	59,3	7	20	4	42	26	18
63	63	38,009	26	32	29	53	72,3	7	25	5	42	26	18

Vorgewuchtet **G 6,3 15.000 min⁻¹**
Pre-balanced
Pré-équilibré
G 2,5 Feinwuchten gegen Aufpreis
G 2.5 Fine balancing at extra charge
G 2,5 Equilibrage fin contre un supplément
Werkstoff: Legierter Einsatzstahl mit einer Zugfestigkeit im Kern von min. 950 N / mm².
 Einsatzgehärtet HRC 60 ± 2 (HV 700 ± 50), Härtetiefe 0,8 mm ± 0,2 mm

Genauigkeit: Kegelwinkel – Toleranzqualität < AT 3 nach DIN 7187.

Material: *Alloyed case-hardened steel, tensile core strength of min. 950 N / mm².*
Case hardened HRC 60 ± 2 (HV 700 ± 50), hardening depth 0.8 mm ± 0.2 mm
Accuracy: *Quality of taper < AT 3 according to DIN 7187.*
Matière: Acier de cémentation allié. Résistance à la traction dans le noyau de min 950 N / mm².
 Cémentation à HRC 60 ± 2 (HV 700 ± 50), profondeur de cémentation 0,8 mm ± 0,2 mm

Précision: Qualité du cône < AT 3 suivant DIN 7187.

Normative Verweise:

 DIN 69893-1:2011
 Kegel-Hohlschäfte mit Plananlage besteht aus:
 - Teil 6: Kegel-Hohlschäfte Form F
 Maße und Ausführung

Normative references:

 DIN 69893-1:2011
 Hollow taper shanks with flange contact surface:
 - Part 1: Part 6: Hollow taper shank type F;
 Dimensions and design

Références normatives:

 DIN 69893-1:2011
 Queues creuses coniques à surface de contact plane:
 - Partie 1: Queues creuses coniques type A et type C;
 Dimensions et conception



Index
Sommaire

 5.85	 5.86	 5.87	 5.88
 5.89	 5.91	 5.92	 5.93
 5.94	 5.95	 5.96	 5.97
 5.99			

Collet chucks for collets ISO 10897 (DIN 6388) OZ-system
Mandrins à pinces pour pinces ISO 10897 (DIN 6388) système OZ



Verwendung:
Zur Aufnahme von Werkzeugen mit Zylinderschaft in Spannzangen.

Application:
For mounting straight-shank tools in collets.

Application:
Destiné à recevoir les outils avec les queues de forme cylindrique dans les pinces de serrage.

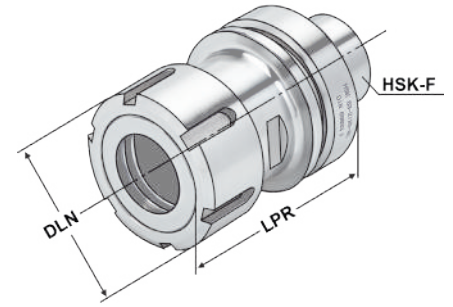

Bestell-Nr. Order no. Référence	HSK	DCONWS Spannbereich Capacity Capacité	Typ	LPR	DLN	DRVS
F63.01.25	HSK-F 63	2 – 25	462E OZ 25	85	60	44

5

Lieferumfang: Mit gewichteter Spannmutter
Delivery: With balanced clamping nut
Livraison: Avec écrou de serrage équilibré

Gewuchtete Ausführung



Balanced type
Type équilibré

Bestell-Nr. Order no. Référence	Abmessung Size Dimension
---------------------------------------	--------------------------------

Wuchten auf G 2,5 von vorgewuchteten Kemmler-Werkzeugen

Balancing at G 2.5 of pre-balanced Kemmler-tools

Équilibrage sur G 2,5 d'outils Kemmler pré-équilibrés

W25 **Ohne Wuchtprotokoll**
Without balancing report
Sans protocole d'équilibrage

W25.2 **Mit Wuchtprotokoll**
With balancing report
Avec protocole d'équilibrage

Wuchten von nicht vorgewuchteten Werkzeugen
Balancing of unbalanced tools
Équilibrage d'outils non-équilibrés

W25.1 **Ohne Wuchtprotokoll**
Without balancing report
Sans protocole d'équilibrage



Collet chucks for collets ISO 15488 (DIN 6499) ER-system
Mandrins à pinces pour pinces ISO 15488 (DIN 6499) système ER



Verwendung:
Zur Aufnahme von Werkzeugen mit Zylinderschaft in Spannzangen.
Application:
For mounting straight-shank tools in collets.
Application:
Destiné à recevoir les outils avec les queues de forme cylindrique dans les pinces de serrage.

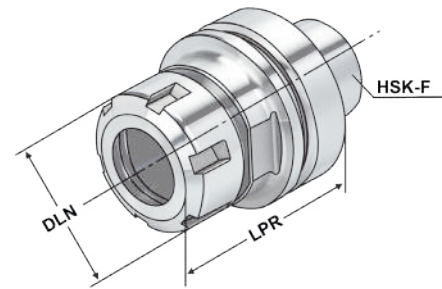

ISO 12164 Form F $\leq 3\mu\text{m}$ G2.5 25,000 min⁻¹ ISO 15488

13.04

Bestell-Nr. Order no. Référence	HSK	DCONWS Spannbereich Capacity Capacité	Typ	LPR	DLN	THID	DRVS
F40.02.10 ¹	HSK-F 40	1 – 10	426E ER 16	60	28	M10 x 1,5	24
F40.02.16	HSK-F 40	2 – 16	430E ER 25	60	42	M16 x 2,0	27
F50.02.16	HSK-F 50	2 – 16	430E ER 25	70	42	M16 x 2,0	36
F50.02.20	HSK-F 50	2 – 20	470E ER 32	80	50	M16 x 2,0	36
F50.02.26	HSK-F 50	3 – 26	472E ER 40	80	63	M16 x 2,0	46
F63.02.10	HSK-F 63	1 – 10	426E ER 16	60	32	M10 x 1,5	27
F63.02.16	HSK-F 63	2 – 16	430E ER 25	70	42	M16 x 2,0	38
F63.02.20	HSK-F 63	2 – 20	470E ER 32	70	50	M16 x 2,0	46
F63.02.26	HSK-F 63	3 – 26	472E ER 40	75	63	M16 x 2,0	46
F63.02.10.1	HSK-F 63	1 – 10	426E ER 16	100	32	M10 x 1,5	27
F63.02.16.1	HSK-F 63	2 – 16	430E ER 25	100	42	M16 x 2,0	38
F63.02.20.1	HSK-F 63	2 – 20	470E ER 32	100	50	M16 x 2,0	46
F63.02.26.1	HSK-F 63	3 – 26	472E ER 40	100	63	M16 x 2,0	46
F63.02.10.2	HSK-F 63	1 – 10	426E ER 16	160	32	M10 x 1,5	27
F63.02.16.2	HSK-F 63	2 – 16	430E ER 25	160	42	M16 x 2,0	38
F63.02.20.2	HSK-F 63	2 – 20	470E ER 32	160	50	M16 x 2,0	46
F63.02.26.2	HSK-F 63	3 – 26	472E ER 40	160	63	M16 x 2,0	46

¹ Sechskantmutter
¹ Hexagonal clamping nut
¹ Écrous hexagonal

Lieferumfang: Mit gewuchteter Spannmutter
Delivery: With balanced clamping nut
Livraison: Avec écrou de serrage équilibré





für Spannzangen ISO 15488 (DIN 6499) System ER

Precision collet chuck ER for collets ISO 15488 (DIN 6499) ER-system

Mandrin à pinces ER de précision pour pinces ISO 15488 (DIN 6499) système ER



Verwendung:

Zur Aufnahme von Werkzeugen mit Zylinderschaft in 3 µm-Spannzangen.

Application:

For mounting straight-shank tools in 3 µm-collets.

Application:

Pour le serrage d'outils avec queue cylindrique dans des pinces de serrage 3 µm.

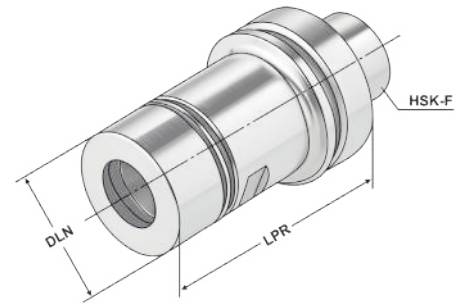

ISO 12164	Form F	$\leq 3\mu\text{m}$	G2.5 25.000 min ⁻¹	ISO 15488
-----------	--------	---------------------	-------------------------------------	-----------

13.04

Bestell-Nr. Order no. Référence	HSK	DCONWS Spannbereich Capacity Capacité	Typ	LPR	LB	DLN	DRVS	THID
F63.P2.20.100	HSK-F 63	2 – 20	470E ER 32	100	71	50	48	M16 x 2,0

5

Vorteile:

Exzellente Rundlaufgenauigkeit im System (Futter + Spannzange + Spannmutter)
 Extreme Haltekraft (erhöht die Haltekraft um mindestens 60 % im Vergleich zu Standard ER-Futter)
 Glatte Spannmutter ohne Nuten für Hochgeschwindigkeitsbearbeitung

Advantages:

Excellent concentricity in the system (chuck + collet + clamping nut)
Extremely strong holding force (increases the holding power by at least 60% compared to standard ER chuck)
Plain clamping nut without grooves for high speed machining

Avantages:

Excellente précision de concentricité dans le système (mandrin + pince de serrage + écrou de serrage)
 La force de maintien extrême (augmente la force de maintien d'au moins à 60% par rapport aux mandrins standards ER)
 Écrou de serrage lisse sans rainures pour l'usinage à haute vitesse

Hinweis:

Nur das Nennmaß DCONWS kann gespannt werden.

Note:

Only nominal size DCONWS can be clamped.

Observation:

Seulement la dimension nominale DCONWS peut être serrée.

Lieferumfang:

Inklusive Präzisions-Spannmutter

Delivery:

With precision clamping nut

Livraison:

Avec écrou de serrage de précision



Collet chucks for collets | KPS-system
Mandrins à pinces pour pinces | Système KPS



Verwendung:
Zur Aufnahme von Werkzeugen mit Zylinderschaft in Spannzangen.
Für Anwendungen im HSC-Bereich und für hochpräzise Bearbeitungsergebnisse.

Application:
For mounting straight-shank tools in collets.
To use for high speed cutting and high precision milling.

Utilisation:
Pour la fixation d'outils à queue cylindrique dans les pinces de serrage. Pour l'UGV (Usinage à Grande Vitesse) et pour des résultats d'usinage de haute précision.

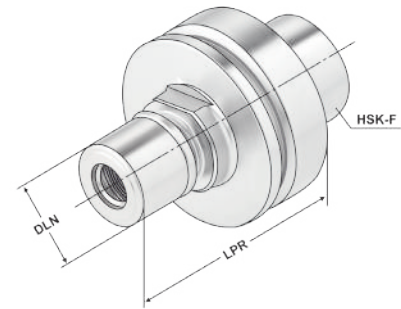

Bestell-Nr. Order no. Référence	HSK	DCONWS Spannbereich Capacity Capacité	Typ	LPR	DLN	DRVS	THID
F63.03.10	HSK-F 63	1 - 10	490EK KPS 10	90	27,5	26	M12 x 1,75
F63.03.16	HSK-F 63	1 - 10	496EK KPS 16	90	27,5	38	M12 x 1,75

5

Lieferumfang: Mit gewuchteter Spannmutter
Delivery: With balanced clamping nut
Livraison: Avec écrou de serrage équilibré

Gewuchtete Ausführung



Balanced type Type équilibré

Bestell-Nr. Order no. Référence	Abmessung Size Dimension
---------------------------------------	--------------------------------

Wuchten auf G 2,5 von vorgewuchteten Kemmler-Werkzeugen

Balancing at G 2.5 of pre-balanced Kemmler-tools
Équilibrage sur G 2,5 d'outils Kemmler pré-équilibrés

W25 **Ohne Wuchtprotokoll**
Without balancing report
Sans protocole d'équilibrage

W25.2 **Mit Wuchtprotokoll**
With balancing report
Avec protocole d'équilibrage

Wuchten von nicht vorgewuchteten Werkzeugen
Balancing of unbalanced tools
Équilibrage d'outils non-équilibrés

W25.1 **Ohne Wuchtprotokoll**
Without balancing report
Sans protocole d'équilibrage



End mill holders DIN 6359 for end mills DIN 1835-B
 Porte-fraises DIN 6359 pour queues cylindriques DIN 1835-B



Verwendung:
 Zum Spannen von zylindrischen Werkzeugschäften mit seitlicher Spannfläche nach DIN 1835 Form B (Weldon).

Application:
 For mounting straight-shank tools with lateral flat according to DIN 1835 form B (Weldon).

Application:
 Pour le serrage d'outils avec queue cylindrique et avec méplat de serrage latérale suivant DIN 1835 forme B (Weldon).

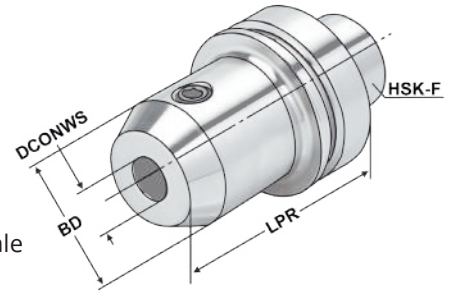

ISO
12164

Form
F

$\leq 3\mu\text{m}$

G2.5
 25.000
 min⁻¹

DIN
1835-B

H4

13.04

5

Bestell-Nr. Order no. Référence	HSK	DCONWS	TDCON	LPR	BD
F63.04.06	HSK-F 63	6	H4	65	25
F63.04.08	HSK-F 63	8	H4	65	28
F63.04.10	HSK-F 63	10	H4	65	35
F63.04.12	HSK-F 63	12	H4	80	42
F63.04.14	HSK-F 63	14	H4	80	44
F63.04.16	HSK-F 63	16	H4	80	48
F63.04.18	HSK-F 63	18	H4	80	48
F63.04.20	HSK-F 63	20	H4	80	52
F63.04.25	HSK-F 63	25	H4	110	65
F63.04.32	HSK-F 63	32	H4	110	72

Hinweis: Ab DCONWS = 25 mit zwei Spannschrauben
Note: From DCONWS = 25 on two clamping screws
Observation: A partir de DCONWS = 25 avec deux vis de serrage

Lieferumfang: Mit Spannschraube
Delivery: With clamping screw
Livraison: Avec vis de serrage



End mill holders DIN 6359 for end mills DIN 1835-E
Porte-fraises DIN 6359 pour queues cylindriques DIN 1835-E



Verwendung:
Zum Spannen von zylindrischen
Werkzeugschäften mit geneigter Spannflä-
che nach DIN 1835 Form E (Whistle Notch).

Application:
For mounting straight-shank tools and
inclined flat according to DIN 1835 form E
(Whistle Notch).

Application:
Pour le serrage d'outils avec queue
cylindrique et avec méplat incliné suivant
DIN 1835 forme E (Whistle Notch).

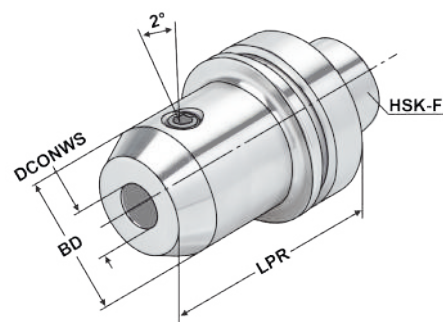

Bestell-Nr. Order no. Référence	HSK	DCONWS	TDCON	LPR	BD
F63.05.06	HSK-F 63	6	H4	100	25
F63.05.08	HSK-F 63	8	H4	100	28
F63.05.10	HSK-F 63	10	H4	100	35
F63.05.12	HSK-F 63	12	H4	100	42
F63.05.14	HSK-F 63	14	H4	100	44
F63.05.16	HSK-F 63	16	H4	100	48
F63.05.18	HSK-F 63	18	H4	100	48
F63.05.20	HSK-F 63	20	H4	100	52
F63.05.25	HSK-F 63	25	H4	120	65
F63.05.32	HSK-F 63	32	H4	120	72

Hinweis: Ab DCONWS = 25 mit zwei Spannschrauben
Note: From DCONWS = 25 on two clamping screws
Observation: A partir de DCONWS = 25 avec deux vis de serrage

Lieferumfang: Mit Spannschraube und axialer Verstelle schraube
Delivery: With clamping screw and axial adjustment bolt
Livraison: Avec vis de serrage et vis de butée axiale

Gewuchtete Ausführung

Balanced type Type équilibré



Bestell-Nr. Order no. Référence	Abmessung Size Dimension
Wuchten auf G 2,5 von vorgewuchteten Kemmler-Werkzeugen Balancing at G 2.5 of pre-balanced Kemmler-tools Équilibrage sur G 2,5 d'outils Kemmler pré-équilibrés	
W25	Ohne Wuchtprotokoll Without balancing report Sans protocole d'équilibrage
W25.2	Mit Wuchtprotokoll With balancing report Avec protocole d'équilibrage
Wuchten von nicht vorgewuchteten Werkzeugen Balancing of unbalanced tools Équilibrage d'outils non-équilibrés	
W25.1	Ohne Wuchtprotokoll Without balancing report Sans protocole d'équilibrage





mit vergrößerter Anlagefläche

Shell mill holders DIN 6357 with enlarged contact face
Porte-fraises à trou lisse DIN 6357 avec face de contact élargie



Verwendung: Zur Aufnahme von Messerköpfen und Fräsern mit Quernut.

Application: For mounting milling cutters with transversal groove.

Application: Destiné à recevoir les fraises et les fraises avec des rainures transversales.

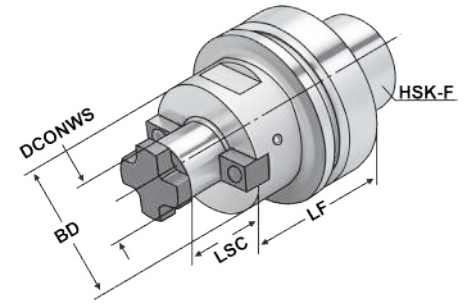

ISO 12164, Form F, surface finish <= 5µm, G2.5 25.000 min⁻¹, DIN 6357, h6, 13.04

5

Table with 8 columns: Bestell-Nr./Order no./Référence, HSK, DCONWS, TCDCON, LF, LSC, BD, DRVS. It lists various part numbers and their dimensions.

DCONWS = 40 Für große Planfräser mit vier zusätzlichen Gewindebohrungen nach DIN 2079. For large diameter face mill cutters with four additional threaded holes according to DIN 2079. Pour fraises à surfacer à grands diamètres avec 4 taraudages supplémentaires suivant DIN 2079.

Lieferumfang: Mit Mitnehmersteinen, Kreuzschraube und Zylinderkopfschraube nach DIN 912 für Fräser mit innerer Kühlmittelzufuhr. Delivery: With drivers, cross head retaining screw and cylinder head retaining screw for cutters with central coolant. Livraison: Avec tenon d entraînement, vis cruciforme et vis à têtes cylindrique suivant DIN 912 pour les fraises avec arrosage central.



CNC-Drill chucks for clockwise and counter clockwise rotation
Mandrins de perçage CNC pour rotation gauche-droite



Verwendung:
Zur Aufnahme von Werkzeugen mit Zylinderschaft.
Application:
For mounting tools with straight shanks.
Application:
Pour le serrage d'outils avec queue cylindrique.

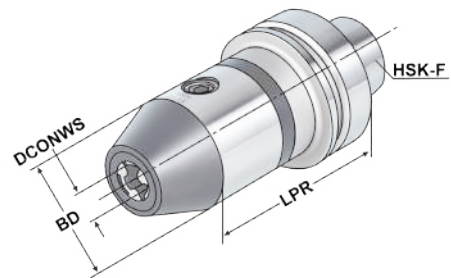

ISO
12164

Form
F

≤ 30µm

G6.3
15.000
min⁻¹

13.04

Bestell-Nr. Order no. Référence	HSK	DCONWS Spannbereich Capacity Capacité	LPR	BD	DRVS
F63.15.13	HSK-F 63	1,0 – 13	110	50	6
F63.15.16	HSK-F 63	2,5 – 16	115	50	6

5

Hinweis: Hohe Präzision und Rundlaufgenauigkeit von ≤ 0,03 mm. Sichere Spannung des Werkzeuges durch mechanische Spannkraftverstärkung. Kein selbständiges Lösen der Spannung während der Bearbeitung bei Links- oder Rechtslauf, sowie bei Spindelstop. Spannen und Lösen mit Sechskantschlüssel.

Note: *High precision and accurate concentricity of ≤ 0.03 mm. Secure gripping of the tool through mechanical amplification of the clamping force. No automatic slackening of the clamping force while machining with either clockwise or counter clockwise rotation or on spindle stop. Clamping and releasing effected by means of an Allen wrench.*

Observation: Précision élevée et exactitude de circularité de ≤ 0,03 mm. Serrage sûr de l'outil grâce à l'amplification de la force de serrage. Pas de desserrage intempestif en cours d'usinage lors de la rotation la gauche ou la droite, de même qu'en cas d'arrêt de la broche. Serrage et desserrage en utilisant un clé sur à fourche.

Lieferumfang: Ohne Spannschlüssel
Delivery: Without wrench
Livraison: Sans clé de serrage



Quick change tapping chucks with length compensation on compression and expansion
 Mandrins de taraudage à changement rapide avec compensation longitudinale à la compression et traction



Verwendung:
 Zur Aufnahme von Schnellwechsel-Einsätzen für Gewindebohrer.

Application:
 For the chucking of quick change adaptors for taps.

Application:
 Pour le serrage d'adaptateurs porte-tarauds à changement rapide.

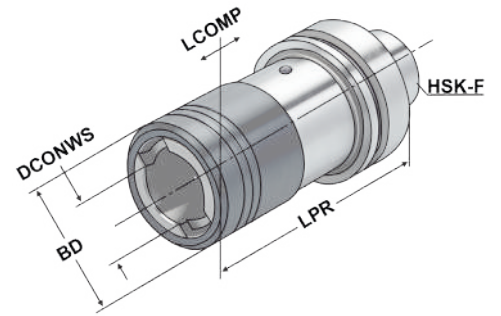

5

Bestell-Nr. Order no. Référence	HSK	Spannbereich Capacity Capacité	SZID	DCONWS	LPR	BD	LCOMP
F63.16.12	HSK-F 63	M3 - M14	1	19	102	36	7
F63.16.20	HSK-F 63	M5 - M22	2	31	140	53	12

Hinweis: Für Bearbeitungszentren ohne Synchronspindel.
Note: For machining centres without synchronous spindle.
Observation: Pour centres d'usinage sans broche synchrone.





Adaptor sleeves for MT with tang DIN 6383
 Douilles de réduction pour CM à tenon DIN 6383



Verwendung:
 Zur Aufnahme von Werkzeugen mit Morsekegelschaft und Austreibblappen nach DIN 228-1 Form B.

Application:
 For mounting tools with Morse taper shank and tang according to DIN 228-1 form B.

Application:
 Pour le serrage d'outils avec queue cône Morse et tenon suivant DIN 228-1 forme B.

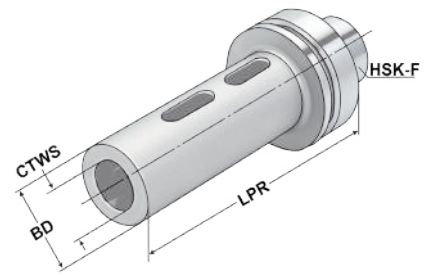

ISO 12164 Form F $\leq 5\mu\text{m}$ G6.3 15.000 min⁻¹ DIN 6383 AT5

Bestell-Nr. Order no. Référence	HSK	CTWS	TDCON	LPR	BD
F63.07.01	HSK-F 63	1	AT5	100	25
F63.07.02	HSK-F 63	2	AT5	120	32
F63.07.03	HSK-F 63	3	AT5	140	40
F63.07.04	HSK-F 63	4	AT5	160	48





Boring bar blanks
Barres d'alésage



Verwendung:
Zur Herstellung von Sonderwerkzeugen.
Application:
For the manufacturing of special tools.
Application:
Pour la fabrication d'outils spéciaux.

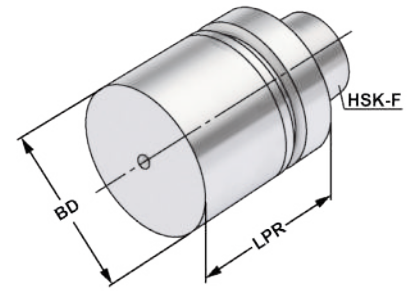

ISO 12164 Form F

5

Bestell-Nr. Order no. Référence	HSK	LPR	BD
F63.17.63	HSK-F 63	125	63
F63.17.63.1	HSK-F 63	250	63

Ausführung: Kegel und Bund gehärtet und geschliffen. Schaft weich zur weiteren Bearbeitung.
Version: *Cone and flange hardened and adjusted. Soft body for later processing.*
Version: Cône et collerette durcis et rectifiés. Corps doux pour un usinage ultérieur.

Test arbors
Mandrins de contrôle



Verwendung:
Zur Abnahme von Werkzeugmaschinen gemäß ISO-Empfehlung R230 oder zur Überprüfung der Werkzeugspindel.

Application:
For the inspection of machine tools according to ISO recommendation R230 or for testing the tool spindle.

Application:
Pour l'inspection de machine-outils suite à la recommandation ISO R230 ou pour la vérification de la broche.

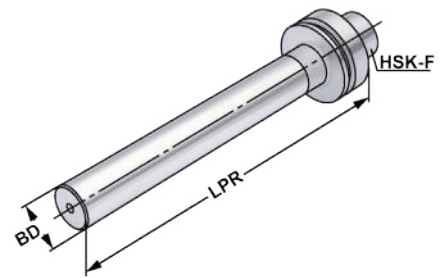

ISO 12164	Form F	$\leq 3\mu\text{m}$
--------------	-----------	---------------------

Bestell-Nr. Order no. Référence	HSK	LPR	BD	Toleranz Tolerance Tolérance	max. Rundlaufabweichung max. concentricity deviation Faux-rond max.
F63.18.40	HSK-F 63	346	40	0,003	0,003

5

Lieferumfang: Auslieferung mit Prüfprotokoll
Delivery: *Delivery with test certificate*
Livraison: Livraison avec rapport d essais

Holzkasten für Kontrolldorne

Wooden box for test arbors
Coffret en bois pour mandrins de contrôle



Verwendung:
Zur Aufbewahrung von Kontrolldornen.

Application:
For the storage of test arbors.

Application:
Pour la conservation de mandrins de contrôle.



Bestell-Nr. Order no. Référence	Abmessung Size Dimension	für Kegelgrößen for cones pour cônes
701.18	460 × 130 × 115	HSK 32 / 40 / 50 / 63 / 80 / 100



zum Spannen von HM und HSS Werkzeugschäften

Shrink chucks 4,5° for mounting of solid carbide and HSS-tool shanks

Mandrins de frettage 4,5° pour le serrage de queues d'outils carbures de type HM et HSS



Verwendung:
Zur Aufnahme von Werkzeugen mit Zylinderschaft.

Application:
For mounting straight-shank tools.

Application:
Pour le serrage d'outils avec queue cylindrique.

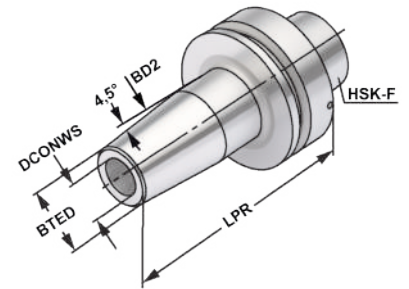

5

Bestell-Nr. Order no. Référence	HSK	DCONWS	TDCON	LPR	BTED	BD2	LSCN	LSCX	ADJRGA	THID
F63.70.03	HSK-F 63	3	h4	80	11	15	9	-	-	-
F63.70.04	HSK-F 63	4	h4	80	14	22	9	-	-	-
F63.70.05	HSK-F 63	5	h4	80	16	22	10	-	-	-
F63.70.06	HSK-F 63	6	h6	80	21	27	22	36	10	M5x0,8
F63.70.08	HSK-F 63	8	h6	80	21	27	26	36	10	M6x1
F63.70.10	HSK-F 63	10	h6	85	24	32	31	41	10	M8x1
F63.70.12	HSK-F 63	12	h6	90	24	32	36	46	10	M10x1
F63.70.14	HSK-F 63	14	h6	95	27	34	36	46	10	M10x1
F63.70.16	HSK-F 63	16	h6	95	27	34	39	49	10	M12x1
F63.70.18	HSK-F 63	18	h6	95	33	42	39	49	10	M12x1
F63.70.20	HSK-F 63	20	h6	100	33	42	41	51	10	M16x1
F63.70.25	HSK-F 63	25	h6	115	44	54	47	57	10	M16x1
F63.70.03.1	HSK-F 63	3	h4	120	11	15	9	-	-	-
F63.70.04.1	HSK-F 63	4	h4	120	16	22	9	-	-	-
F63.70.05.1	HSK-F 63	5	h4	120	16	22	10	-	-	-
F63.70.06.1	HSK-F 63	6	h6	120	21	27	22	36	10	M5x0,8
F63.70.08.1	HSK-F 63	8	h6	120	21	27	26	36	10	M6x1
F63.70.10.1	HSK-F 63	10	h6	120	24	32	31	41	10	M8x1
F63.70.12.1	HSK-F 63	12	h6	120	24	32	36	46	10	M10x1
F63.70.14.1	HSK-F 63	14	h6	120	27	34	36	46	10	M10x1
F63.70.16.1	HSK-F 63	16	h6	120	27	34	39	49	10	M12x1
F63.70.18.1	HSK-F 63	18	h6	120	33	42	39	49	10	M12x1
F63.70.20.1	HSK-F 63	20	h6	120	33	42	41	51	10	M16x1

LSCX = Einspannlänge, max.
LSCX = Clamping depth, max.
LSCX = Profondeur d'insertion, max.

ADJRGA = Verstellweg, max.
ADJRGA = Length adjustment range, max.
ADJRGA = Course de réglage, max.

Für Ø 3, 4 und 5 mm nur Hartmetallschäfte verwenden!

For Ø 3, 4 and 5 mm only solid carbide tool shanks must be used!

Pour Ø 3, 4 et 5 mm il faut seulement utiliser de queues d'outils carbures de type HM!

Hinweis: Aufnahme für Induktiv-, Kontakt- und Heißluftschumpfgeräte geeignet. Schafttoleranz bei Ø 3, 4 und 5 mm = h₄, bei Ø 6 - Ø 32 mm = h₆

Note: Toolholders suitable for induction-, contact- and hot air shrink units. Ø 3, 4, 5 with h₄-tolerance and Ø 6 - Ø 32 with h₆-tolerance

Observation: Porte-outils convenables pour machines à fretter par induction, par contact, ou par air chaud. Ø 3, 4, 5 avec h₄-tolerance et Ø 6 - Ø 32 avec h₆-tolerance





zum Spannen von HM und HSS Werkzeugschäften

Shrink chucks 4,5° for mounting of solid carbide and HSS-tool shanks

Mandrins de frettage 4,5° pour le serrage de queues d'outils carbures de type HM et HSS



Verwendung:
Zur Aufnahme von Werkzeugen mit Zylinderschaft.

Application:
For mounting straight-shank tools.

Application:
Pour le serrage d'outils avec queue cylindrique.

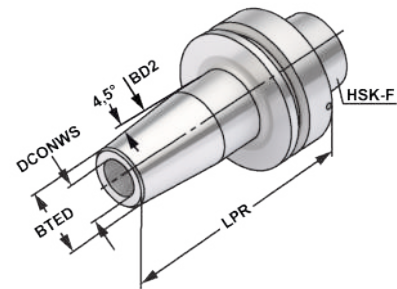

ISO 12164 Form F $\leq 3\mu\text{m}$ G2.5 25.000 min⁻¹ h6

Bestell-Nr. Order no. Référence	HSK	DCONWS	TDCON	LPR	BTED	BD2	LSCN	LSCX	ADJRG	THID
F63.70.04.2	HSK-F 63	4	h4	160	16	22	9	-	-	-
F63.70.05.2	HSK-F 63	5	h4	160	16	22	10	-	-	-
F63.70.06.2	HSK-F 63	6	h6	160	21	27	22	36	10	M5x0,8
F63.70.08.2	HSK-F 63	8	h6	160	21	27	26	36	10	M6x1
F63.70.10.2	HSK-F 63	10	h6	160	24	32	31	41	10	M8x1
F63.70.12.2	HSK-F 63	12	h6	160	24	32	36	46	10	M10x1
F63.70.14.2	HSK-F 63	14	h6	160	27	34	36	46	10	M10x1
F63.70.16.2	HSK-F 63	16	h6	160	27	34	39	49	10	M12x1
F63.70.18.2	HSK-F 63	18	h6	160	33	42	39	49	10	M12x1
F63.70.20.2	HSK-F 63	20	h6	160	33	42	41	51	10	M16x1

5

LSCX = Einspannlänge, max. ADJRG = Verstellweg, max.
 LSCX = Clamping depth, max. ADJRG = Length adjustment range, max.
 LSCX = Profondeur d'insertion, max. ADJRG = Course de réglage, max.

Für Ø 3, 4 und 5 mm nur Hartmetallschäfte verwenden!
 For Ø 3, 4 and 5 mm only solid carbide tool shanks must be used!
 Pour Ø 3, 4 et 5 mm il faut seulement utiliser de queues d'outils carbures de type HM!

Hinweis: Aufnahme für Induktiv-, Kontakt- und Heißluftschumpfergeräte geeignet.
 Schafttoleranz bei Ø 3, 4 und 5 mm = h₄, bei Ø 6 - Ø 32 mm = h₆

Note: Toolholders suitable for induction-, contact- and hot air shrink units.
 Ø 3, 4, 5 with h₄-tolerance and Ø 6 - Ø 32 with h₆-tolerance

Observation: Porte-outils convenables pour machines à frotter par induction, par contact, ou par air chaud.
 Ø 3, 4, 5 avec h₄-tolerance et Ø 6 - Ø 32 avec h₆-tolerance



Nachträgliches Erodieren von 2 Kühlkanalbohrungen

Supplementary eroding of 2 cooling channels

Erodage complémentaire de 2 trous de canaux de refroidissement

Bestell-Nr.
Order no.
Référence

U.KKB





Hydraulic expansion chucks
Mandrins expansibles hydrauliques

**Verwendung:**

Zur Aufnahme von Werkzeugen mit Zylinderschaft nach DIN 1835 Form A+B+E und DIN 6535 Form HA+HB+HE (größer Ø 20 mm nur mit Reduzierung).

Application:

For mounting straight-shank tools acc. DIN 1835 form A+B+E and DIN 6535 form HA+HB+HE (larger).

Application:

Pour le serrage d'outils avec queue cylindrique suivant DIN 1835 forme A+B+E et DIN 6535 forme HA+HB+HE (à partir de dia. 20 mm seulement avec réduction).

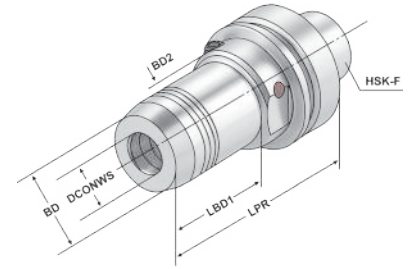

5

Bestell-Nr. Order no. Référence	HSK	DCONWS	LPR	BD	BD2	LSCX	ADJRGA	LBD1	DRVS	THID
F63.H06	HSK-F 63	6	100	26	50	37	10	45	5	M6x1
F63.H08	HSK-F 63	8	100	28	50	37	10	44	5	M6x1
F63.H10	HSK-F 63	10	100	30	50	42	10	46	5	M8x1
F63.H12	HSK-F 63	12	100	32	50	47	10	45,5	5	M8x1
F63.H14	HSK-F 63	14	100	34	50	47	10	44	5	M10x1
F63.H16	HSK-F 63	16	100	38	50	52	10	44	5	M12x1
F63.H18	HSK-F 63	18	100	40	50	52	10	42	5	M12x1
F63.H20	HSK-F 63	20	100	42	50	52	10	42	5	M12x1
F63.H25	HSK-F 63	25	120	50	50	58	10	26	6	M12x1
F63.H32	HSK-F 63	32	125	60	50	62	10	26	6	M12x1

LSCX = Einspannlänge, max.
LSCX = Clamping depth, max.
LSCX = Profondeur d'insertion, max.

ADJRGA = Verstellweg, max.
ADJRGA = Length adjustment range, max.
ADJRGA = Course de réglage, max.

Lieferumfang: Ohne Spannschlüssel
Delivery: Without wrench
Livraison: Sans clé de serrage

Gewuchtete Ausführung



Balanced type Type équilibré

Bestell-Nr. Order no. Référence	Abmessung Size Dimension
---------------------------------------	--------------------------------

Wuchten auf G 2,5 von vorgewuchteten Kemmler-Werkzeugen

Balancing at G 2.5 of pre-balanced Kemmler-tools
Équilibrage sur G 2,5 d'outils Kemmler pré-équilibrés

W25

Ohne Wuchtprotokoll
Without balancing report
Sans protocole d'équilibrage

W25.2

Mit Wuchtprotokoll
With balancing report
Avec protocole d'équilibrage

**Wuchten von nicht vorgewuchteten Werkzeugen
Balancing of unbalanced tools
Équilibrage d'outils non-équilibrés**

W25.1

Ohne Wuchtprotokoll
Without balancing report
Sans protocole d'équilibrage

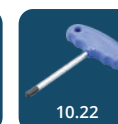
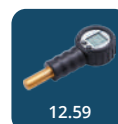
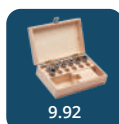

Reparatur und Wartung für Hydro-Dehnspannfutter

Die Hydro-Dehnspanntechnik ist eine weltweit verbreitete, bewährte und zuverlässige Methode zur Aufnahme von Werkzeugen. Dank ihrer konstruktiven Vorteile ist sie unempfindlich, wartungsarm und langlebig. Dennoch kommt es durch thermische und mechanische Belastung im Werkstattgebrauch im Laufe der Zeit zu Spannkraftverlusten. Die Folge sind schlechtere Werkzeugstandzeiten und Qualitätseinbußen bei der Bearbeitung bis hin zum teuren Werkzeugbruch.

Wir warten und reparieren Ihre Hydro-Dehnspannfutter - egal ob von uns oder ein Fremdfabrikat - kostengünstig hier bei uns in Süd-Deutschland.

Hier prüfen wir die Ursachen für den Spannkraftverlust und reparieren innerhalb von zwei Wochen zu einem günstigen Festpreis. Wir erneuern dabei alle Verschleißteile, befüllen das Hydrauliksystem neu und justieren das Hydrauliksystem auf den korrekten Spanndruck. Abschließend erfolgt eine Endprüfung.

Kontaktieren Sie unseren Kundenservice für weitere Informationen und Preise.

Maintenance and repair of hydraulic chucks

Clamping of tools with hydraulic chucks is a widespread, well-established and reliable method.

It is a resistant, easy-to-operate and durable way of clamping due to its advantageous construction design.

Nevertheless in the course of time under the influence of thermal and mechanical outputs at factories loss of clamping force is observed. As a result the life of the tool shortens and its quality during the working process reduces. Therefore it leads to a costly damage of the tool.

We maintain and repair your hydraulic chucks - both those manufactured at our place and those produced somewhere else - for a reasonable price here at our office in the south of Germany.

We check possible causes of the clamping force reduction and repair it within two weeks at a fixed low price. At the same time we renew all the fast wearing parts, fill the hydraulic system anew and adjust its clamping force. Afterwards the final inspection stage takes place.

You are welcome to contact our customer service for further information and prices.

5

La réparation et la maintenance des mandrins hydrauliques

L'accueil des outils à l'aide d'un mandrin hydraulique est une technique éprouvée, répandue à l'échelle mondiale et de confiance. Grâce à sa construction avantageuse elle est robuste, facile à entretenir et durable.

Pourtant à cause de la charge thermique et mécanique imposés sur les mandrins lors du travail la tension du ressort diminue au fil du temps. Par conséquent la résistance des outils coupants se détériore et la qualité lors d'usinage se réduit. En retour cela conduit à la rupture coûteuse d'outil.

On entretient et répare vos mandrins hydrauliques - peu importe l'issue de notre production ou d'ailleurs - bon marché et ici chez nous au sud de l'Allemagne.

Tout d'abord nos spécialistes cherchent la cause de la perte de la tension du ressort, ensuite ils effectuent la réparation sous 2 semaines pour le prix fixe et favorable. En outre ils renouvellent toutes les pièces d'usure, remplissent le système hydraulique à nouveau et ajustent la tension correcte. À la fin l'inspection finale se déroule.

Contactez notre centre de service client pour obtenir l'information supplémentaire ainsi que l'information actuelle sur le prix.



**WERKZEUGAUFNAHMEN
MIT POLYGONALSCHAFT
ISO 26623-1**

**TOOLHOLDERS
POLYGONAL SHANK
ISO 26623-1**

**PORTE-OUTILS
À QUEUE POLYGONALE
ISO 26623-1**

ISO 26623

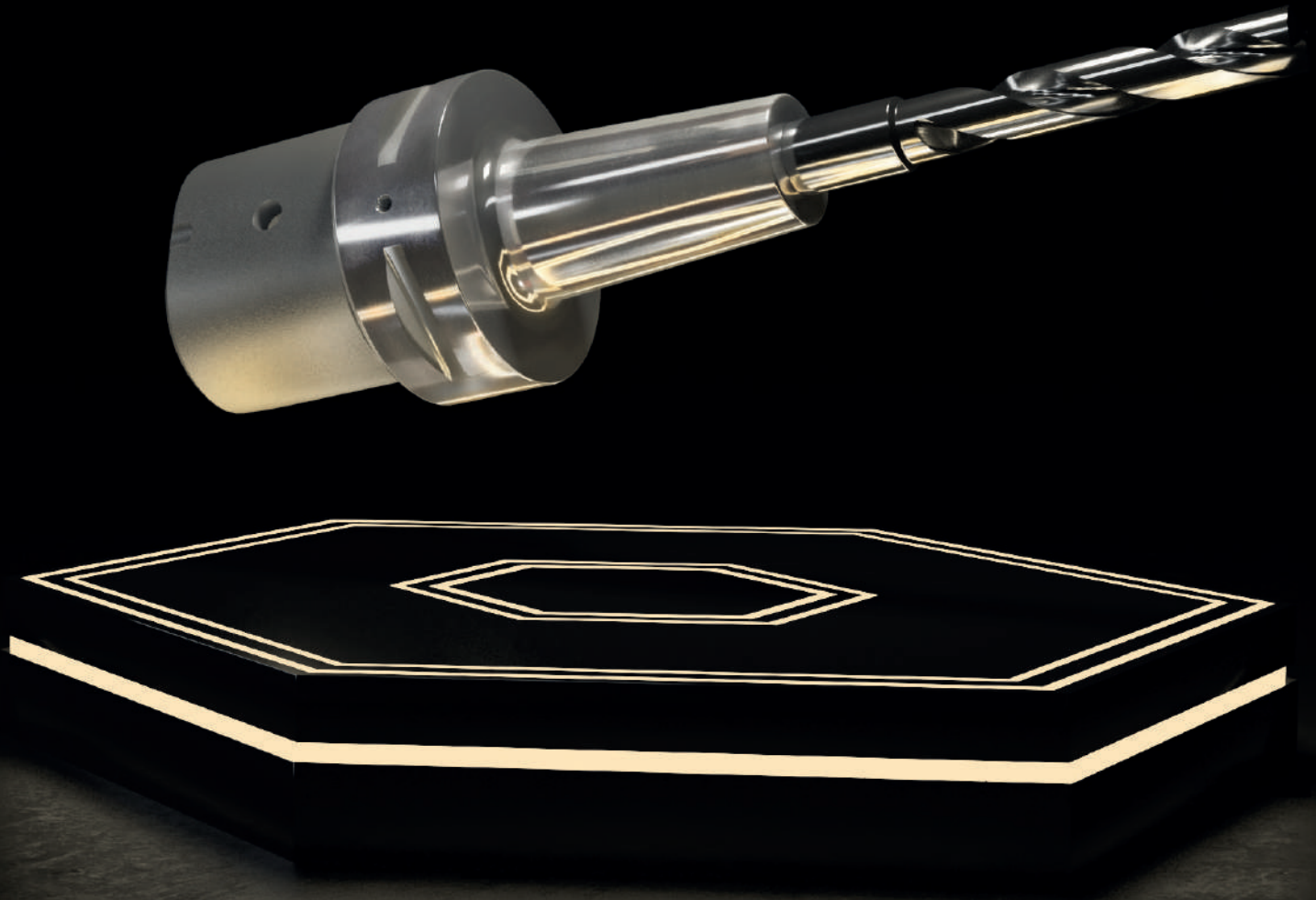

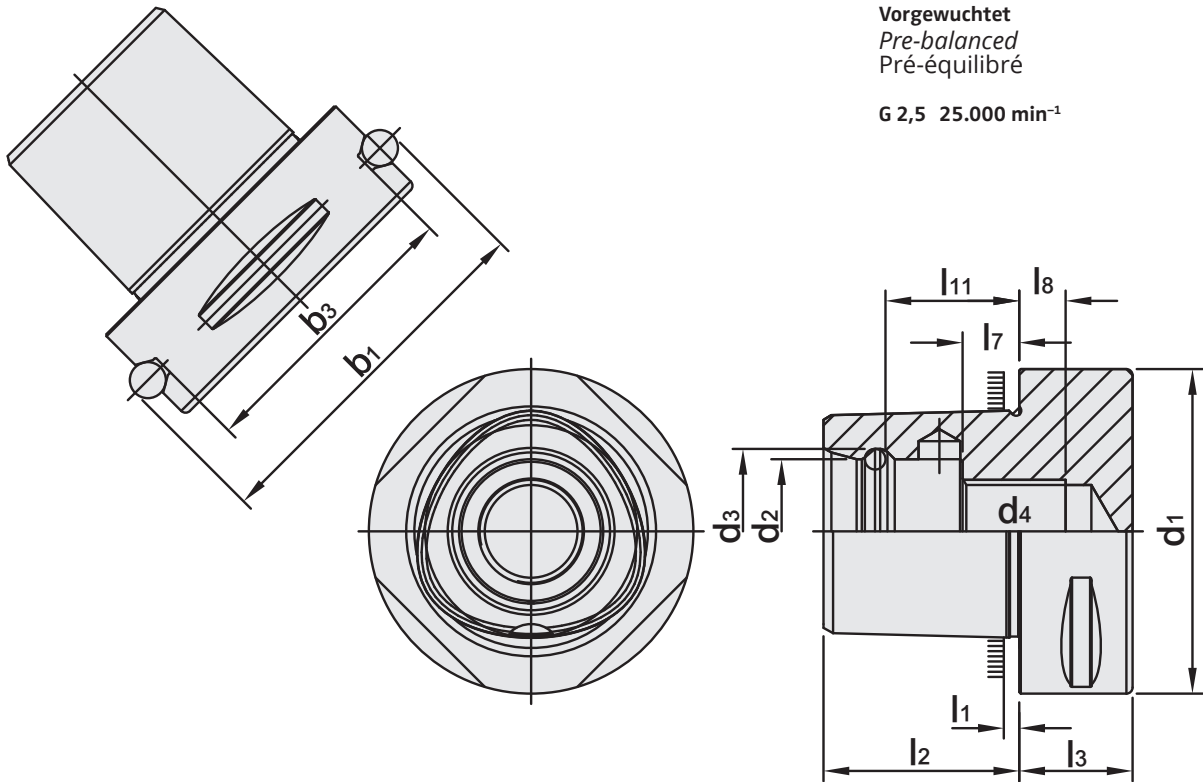
6

PSK	b ₁ ±0,1	b ₃ ±0,1	d ₁ ±0,1	d ₂ +0,1 -0,05	d ₃ ±0,05	d ₄	l ₁	l ₂ ±0,1	l ₃ min	l ₇ ±0,15	l ₈ min	l ₁₁ ±0,1
32	39,0	27,9	32	15	16,5	M12 x 1,5P	2,5	19	15	6	6	13,5
40	46,0	34,9	40	18	20,0	M14 x 1,5P	2,5	24	20	9	6	17,5
50	59,3	44,0	50	21	24,0	M16 x 1,5P	3	30	20	10	7	22,0
63	70,7	55,4	63	28	32,0	M20 x 2,0P	3	38	22	11	9	26,0
80	86,0	70,7	80	32	38,0	M20 x 2,0P	3	48	30	20	10	34,0
100	110,0	88,3	100	43	50,5	M24 x 2,0P	3	60	32	20	10	42,5

Werkstoff: Legierter Einsatzstahl mit einer Zugfestigkeit im Kern von min. 950 N / mm². Einsatzgehärtet HRC 60 ± 2 (HV 700 ± 50), Härtetiefe 0,8 mm ± 0,2 mm, brüniert und präzisionsgeschliffen.

Material: Alloyed case-hardened steel, tensile core strength of min. 950 N / mm². Case hardened HRC 60 ± 2 (HV 700 ± 50), hardening depth 0.8 mm ± 0.2 mm, black-finished and precisely grinded.

Matière: Acier de cémentation allié. Résistance à la traction dans le noyau de min 950 N / mm². Cémentation à HRC 60 ± 2 (HV 700 ± 50), profondeur de cémentation 0,8 mm ± 0,2 mm, bruni et rectifié précisément.

Normative Verweise:

ISO 26623-1:2020-11
 Polygonaler Hohlchaftkegel mit Plananlage
 - Teil 1: Maße und Bezeichnung von Schäften
 - Teil 2: Maße und Bezeichnung von Aufnahmen

Normative references:

ISO 26623-1:2020
 Polygonal taper interface with flange contact surface
 - Part 1: Dimensions and designation of shanks
 - Part 2: Dimensions and designation of receivers

Références normatives:

ISO 26623-1:2020
 Interfaces à cône polygonal avec face d'appui
 - Partie 1: Dimensions et désignation des queues
 - Partie 2: Dimensions et désignation des nez de broche



Index
Sommaire

 6.05	 6.06	 6.07	 6.08
 6.09	 6.10	 6.11	 6.12
 6.13	 6.14	 6.15	 6.16
 6.17	 6.18	 6.19	 6.20
 6.21	 6.22	 6.23	 6.24
 6.25	 6.26	 6.27	 6.28
 6.29	 6.30		

6



ISO 15488 (DIN 6499) System ER

Collet chucks for collets ISO 15488 (DIN 6499) ER-system

Mandrins à pinces pour pinces ISO 15488 (DIN 6499) système ER

**Verwendung:**

Zur Aufnahme von Werkzeugen mit Zylinderschaft in Spannzangen.

Application:

For mounting straight-shank tools in collets.

Application:

Destiné à recevoir les outils avec les queues de forme cylindrique dans les pinces de serrage.

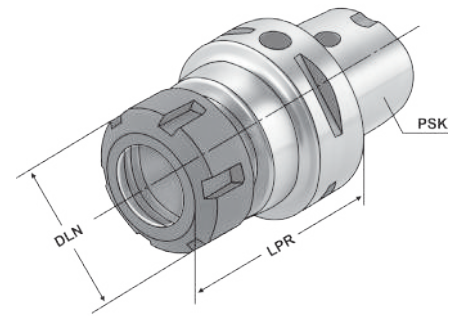

6

Bestell-Nr. Order no. Référence	PSK	DCONWS Spannbereich Capacity Capacité	Typ	LPR	DLN	THID
C3.02.10	C3	1 - 10	426E ER 16	45	32	-
C3.02.13	C3	2 - 13	428E ER 20	45	34	-
C4.02.10	C4	1 - 10	426E ER 16	70	32	-
C4.02.13	C4	2 - 13	428E ER 20	52	34	-
C4.02.16	C4	2 - 16	430E ER 25	52	42	-
C4.02.20	C4	2 - 20	470E ER 32	54	50	-
C5.02.10.1	C5	1 - 10	426E ER 16	100	32	M10x1
C5.02.13	C5	2 - 13	428E ER 20	55	34	-
C5.02.13.1	C5	2 - 13	428E ER 20	100	34	M10x1
C5.02.16	C5	2 - 16	430E ER 25	55	42	-
C5.02.20	C5	2 - 20	470E ER 32	57	50	-
C5.02.20.1	C5	2 - 20	470E ER 32	100	50	M10x1
C6.02.10	C6	1 - 10	426E ER 16	60	32	-
C6.02.16	C6	2 - 16	430E ER 25	60	42	-
C6.02.20	C6	2 - 20	470E ER 32	70	50	-
C6.02.26	C6	3 - 26	472E ER 40	65	63	-
C6.02.10.1	C6	1 - 10	426E ER 16	100	32	M10x1
C6.02.16.1	C6	2 - 16	430E ER 25	100	42	M10x1
C6.02.20.1	C6	2 - 20	470E ER 32	100	50	M10x1
C6.02.26.1	C6	3 - 26	472E ER 40	100	63	M10x1
C6.02.10.130	C6	1 - 10	426E ER 16	130	32	M10x1
C6.02.16.130	C6	2 - 16	430E ER 25	130	42	M10x1
C6.02.20.130	C6	2 - 20	470E ER 32	130	50	M10x1
C6.02.26.130	C6	3 - 26	472E ER 40	130	63	M10x1
C6.02.10.160	C6	1 - 10	426E ER 16	160	32	M10x1
C6.02.16.160	C6	2 - 16	430E ER 25	160	42	M10x1

Lieferumfang: Mit gewuchteter Spannmutter
Delivery: With balanced clamping nut
Livraison: Avec écrou de serrage équilibré

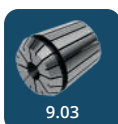

für Spannzangen ISO 15488 (DIN 6499) System ER

Precision collet chuck ER for collets ISO 15488 (DIN 6499) ER-system

Mandrin à pinces ER de précision pour pinces ISO 15488 (DIN 6499) système ER



Verwendung:
Zur Aufnahme von Werkzeugen mit Zylinderschaft in 3 µm-Spannzangen.

Application:
For mounting straight-shank tools in 3 µm-collets.

Application:
Pour le serrage d'outils avec queue cylindrique dans des pinces de serrage 3 µm.

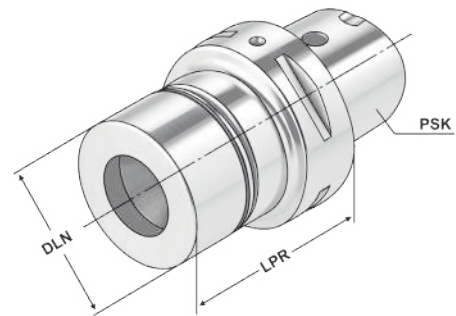

Bestell-Nr. Order no. Référence	PSK	DCONWS Spannbereich Capacity Capacité	Typ	LPR	LB	DLN	THID
C4.P2.20.070	C4	2 - 20	470E ER 32	70	39,5	50	M16 x 2,0
C5.P2.20.070	C5	2 - 20	470E ER 32	70	46	50	M16 x 2,0
C6.P2.20.070	C6	2 - 20	470E ER 32	70	45	50	M16 x 2,0

Vorteile:

Exzellente Rundlaufgenauigkeit im System (Futter + Spannzange + Spannmutter)
Extreme Haltekräfte (erhöht die Haltekraft um mindestens 60 % im Vergleich zu Standard ER-Futter)
Glatte Spannmutter ohne Nuten für Hochgeschwindigkeitsbearbeitung

Advantages:

Excellent concentricity in the system (chuck + collet + clamping nut)
Extremely strong holding force (increases the holding power by at least 60% compared to standard ER chuck)
Plain clamping nut without grooves for high speed machining

Avantages:

Excellente précision de concentricité dans le système (mandrin + pince de serrage + écrou de serrage)
La force de maintien extrême (augmente la force de maintien d'au moins à 60% par rapport aux mandrins standards ER)
Écrou de serrage lisse sans rainures pour l'usinage à haute vitesse

Hinweis: Nur das Nennmaß DCONWS kann gespannt werden.

Note: Only nominal size DCONWS can be clamped.

Observation: Seulement la dimension nominale DCONWS peut être serrée.

Lieferumfang: Inklusive Präzisions-Spannmutter
Delivery: With precision clamping nut
Livraison: Avec écrou de serrage de précision





Collet chucks for collets ISO 15488 (DIN 6499) ER-system - Mini
Mandrins à pinces pour pinces ISO 15488 (DIN 6499) système ER - Mini



Verwendung:
Zur Aufnahme von Werkzeugen mit Zylinderschaft in Spannzangen.

Application:
For mounting straight-shank tools in collets.

Application:
Destiné à recevoir les outils avec les queues de forme cylindrique dans les pinces de serrage.

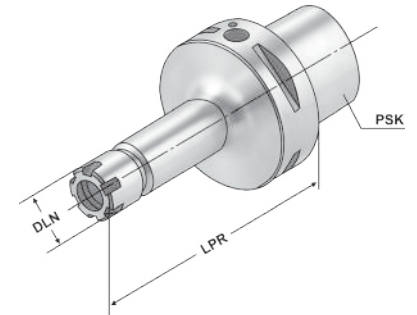

Bestell-Nr. Order no. Référence	PSK	DCONWS Spannbereich Capacity Capacité	Typ	LPR	DLN	THID
C6.02.07.10.100	C6	1 - 10	426E ER 16	100	22	M10x1
C6.02.07.10.130	C6	1 - 10	426E ER 16	130	22	M10x1
C6.02.07.10.160	C6	1 - 10	426E ER 16	160	22	M10x1

6

Lieferumfang: Mit gewichteter Spannmutter
Delivery: With balanced clamping nut
Livraison: Avec écrou de serrage équilibré

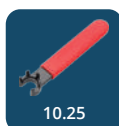

High Performance Milling Chuck | HKS-system
Mandrin de serrage à haute performance | Système HKS



Verwendung:
Zur Aufnahme von Werkzeugen mit Zylinderschaft nach DIN 1835 Form A+B+E und DIN 6535 Form HB+HE

Application:
For mounting straight-shank tools acc. DIN 1835 form A+B+E and DIN 6535 form HB+HE

Application:
Destiné à recevoir les outils avec les queues de forme cylindrique suivant DIN 1835 en forme A+B+E et DIN 6535 en forme HB+HE

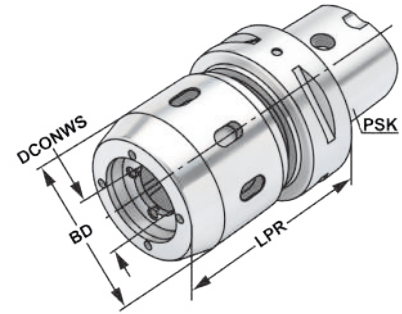

ISO 26623 $\leq 3\mu\text{m}$ G6.3 15.000 min⁻¹ ISO 15488 HKS

13.04

Bestell-Nr. Order no. Référence	PSK	DCONWS Spannbereich Capacity Capacité	Typ	DCONWS	LPR	BD
C5.64.20	C5	3 – 20	HKS 20	20	75	56
C5.64.32	C5	3 – 32	HKS 32	32	90	71
C6.64.20	C6	3 – 20	HKS 20	20	75	56
C6.64.32	C6	3 – 32	HKS 32	32	85	71

6

Größe Size Taille	20mm	25mm	32mm
Anzugsmoment Clamping torque Couple	50-70 Nm	80-100 Nm	80-100 Nm
Spannkraft Clamping force Tension	780 Nm	2000 Nm	2000 Nm

Gewuchtete Ausführung



Balanced type
Type équilibré

Bestell-Nr. Order no. Référence	Abmessung Size Dimension
---------------------------------------	--------------------------------

Wuchten auf G 2,5 von vorgewuchteten Kemmler-Werkzeugen

Balancing at G 2.5 of pre-balanced Kemmler-tools
Équilibrage sur G 2,5 d'outils Kemmler pré-équilibrés

W25 **Ohne Wuchtprotokoll**
Without balancing report
Sans protocole d'équilibrage

W25.2 **Mit Wuchtprotokoll**
With balancing report
Avec protocole d'équilibrage

Wuchten von nicht vorgewuchteten Werkzeugen
Balancing of unbalanced tools
Équilibrage d'outils non-équilibrés

W25.1 **Ohne Wuchtprotokoll**
Without balancing report
Sans protocole d'équilibrage



End mill holders DIN 6359 for end mills DIN 1835-B
 Porte-fraises DIN 6359 pour queues cylindriques DIN 1835-B



Verwendung:
 Zum Spannen von zylindrischen Werkzeugschäften mit seitlicher Spannfläche nach DIN 1835 Form B (Weldon).

Application:
 For mounting straight-shank tools with lateral flat according to DIN 1835 form B (Weldon).

Application:
 Pour le serrage d'outils avec queue cylindrique et avec méplat de serrage latérale suivant DIN 1835 forme B (Weldon).

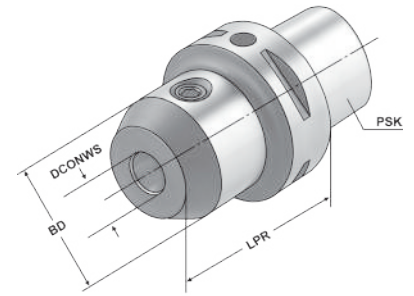

6

Bestell-Nr. Order no. Référence	PSK	DCONWS	TDCON	LPR	BD
C3.04.06	C3	6	H4	45	25
C3.04.08	C3	8	H4	45	28
C3.04.10	C3	10	H4	50	35
C3.04.12	C3	12	H4	55	42
C4.04.06	C4	6	H4	50	25
C4.04.08	C4	8	H4	50	28
C4.04.10	C4	10	H4	50	35
C4.04.12	C4	12	H4	55	42
C4.04.14	C4	14	H4	55	44
C4.04.16	C4	16	H4	55	48
C5.04.06	C5	6	H4	50	25
C5.04.08	C5	8	H4	50	28
C5.04.10	C5	10	H4	55	35
C5.04.12	C5	12	H4	60	42
C5.04.14	C5	14	H4	60	44
C5.04.16	C5	16	H4	60	48
C5.04.18	C5	18	H4	60	50
C5.04.20	C5	20	H4	60	52
C5.04.25	C5	25	H4	80	65

Lieferumfang: Mit Spannschraube
Delivery: With clamping screw
Livraison: Avec vis de serrage

Hinweis: Ab DCONWS = 25 mit zwei Spannschrauben
Note: From DCONWS = 25 on two clamping screws
Observation: A partir de DCONWS = 25 avec deux vis de serrage



Nachträgliches Erodieren von 2 Kühlkanalbohrungen
Supplementary eroding of 2 cooling channels
 Erodage complémentaire de 2 trous de canaux de refroidissement

Bestell-Nr.
Order no.
Référence

U.KKB



End mill holders DIN 6359 for end mills DIN 1835-B

Porte-fraises DIN 6359 pour queues cylindriques DIN 1835-B

**Verwendung:**

Zum Spannen von zylindrischen Werkzeugschäften mit seitlicher Spannfläche nach DIN 1835 Form B (Weldon).

Application:

For mounting straight-shank tools with lateral flat according to DIN 1835 form B (Weldon).

Application:

Pour le serrage d'outils avec queue cylindrique et avec méplat de serrage latérale suivant DIN 1835 forme B (Weldon).

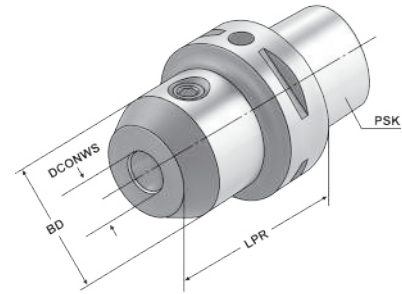

Bestell-Nr. Order no. Référence	PSK	DCONWS	TDCON	LPR	BD
C6.04.06	C6	6	H4	55	25
C6.04.08	C6	8	H4	55	28
C6.04.10	C6	10	H4	60	35
C6.04.12	C6	12	H4	60	42
C6.04.14	C6	14	H4	60	44
C6.04.16	C6	16	H4	65	48
C6.04.18	C6	18	H4	65	50
C6.04.20	C6	20	H4	65	52
C6.04.25	C6	25	H4	80	65
C6.04.32	C6	32	H4	90	72
C6.04.40	C6	40	H4	100	80
C6.04.06.1	C6	6	H4	100	25
C6.04.08.1	C6	8	H4	100	28
C6.04.10.1	C6	10	H4	100	35
C6.04.12.1	C6	12	H4	100	42
C6.04.14.1	C6	14	H4	100	44
C6.04.16.1	C6	16	H4	100	48
C6.04.18.1	C6	18	H4	100	50
C6.04.20.1	C6	20	H4	100	52

6

Lieferumfang: Mit Spannschraube
Delivery: With clamping screw
Livraison: Avec vis de serrage

Hinweis: Ab DCONWS = 25 mit zwei Spannschrauben
Note: From DCONWS = 25 on two clamping screws
Observation: A partir de DCONWS = 25 avec deux vis de serrage





für Zylinderschäfte DIN 1835-B

End mill holders DIN 6359 with coolant channels for end mills DIN 1835-B

Porte-fraises DIN 6359 avec canaux d'arrosage pour queues cylindriques DIN 1835-B

**Verwendung:**

Zum Spannen von zylindrischen Werkzeugschäften mit seitlicher Spannfläche nach DIN 1835 Form B (Weldon). Mit Kühlkanälen für optimale Kühlung der Werkzeugschneide.

Application:

For mounting straight-shank tools with lateral flat according to DIN 1835 form B (Weldon). With coolant channels for optimal coolant at the cutting edge.

Application:

Pour le serrage d'outils avec queue cylindrique et avec méplat de serrage latéral suivant DIN 1835 forme B (Weldon). Avec canaux d'arrosage pour refroidissement optimal des coupes.

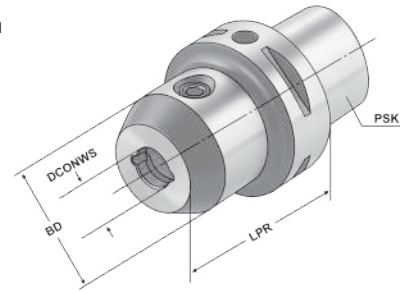

Bestell-Nr.
Order no.
Référence

Bestell-Nr. Order no. Référence	PSK	DCONWS	TDCON	LPR	BD
C6.04.06.K	C6	6	H4	55	25
C6.04.08.K	C6	8	H4	55	28
C6.04.10.K	C6	10	H4	60	35
C6.04.12.K	C6	12	H4	60	42
C6.04.14.K	C6	14	H4	60	44
C6.04.16.K	C6	16	H4	65	48
C6.04.18.K	C6	18	H4	65	50
C6.04.20.K	C6	20	H4	65	52
C6.04.25.K	C6	25	H4	80	65
C6.04.32.K	C6	32	H4	90	72
C6.04.40.K	C6	40	H4	100	80
C6.04.06.1.K	C6	6	H4	100	25
C6.04.08.1.K	C6	8	H4	100	28
C6.04.10.1.K	C6	10	H4	100	35
C6.04.12.1.K	C6	12	H4	100	42
C6.04.14.1.K	C6	14	H4	100	44
C6.04.16.1.K	C6	16	H4	100	48
C6.04.20.1.K	C6	20	H4	100	52
C6.04.06.2.K	C6	6	H4	160	25
C6.04.08.2.K	C6	8	H4	160	28
C6.04.10.2.K	C6	10	H4	160	35
C6.04.12.2.K	C6	12	H4	160	42
C6.04.16.2.K	C6	16	H4	160	48

Hinweis: Ab DCONWS = 25 mit zwei Spannschrauben
DCONWS = 6 bis 18 mit zwei Kühlkanälen
DCONWS = 20 bis 40 mit vier Kühlkanälen

Für Werkzeuge mit innerer Kühlmittelzufuhr muss ein O-Ring eingesetzt werden.

Note: From DCONWS = 25 on two clamping screws
DCONWS = 6 to 18 with two coolant channels
DCONWS = 20 to 40 with four coolant channels

For tools with through coolant an O-ring must be used.

Observation: À partir de DCONWS = 25 avec deux vis de serrage
DCONWS = 6 bis 18 avec deux canaux d'arrosage
DCONWS = 20 bis 40 avec quatre canaux d'arrosage
Pour outils avec arrosage interne il faut utiliser un joint torique.

Lieferumfang: Mit Spannschraube
Delivery: With clamping screw
Livraison: Avec vis de serrage

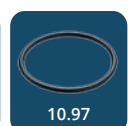

Anlagefläche und Kühlkanalbohrungen an der Stirnseite

Shell mill holders DIN 6357 with enlarged contact face and coolant exit bores on the end face
 Porte-fraises à trou lisse DIN 6357 avec face de contact élargie et conduits pour l'arrosage frontal



Verwendung:
 Zur Aufnahme von Messerköpfen und Fräsern mit Quernut.

Application:
 For mounting milling cutters with transversal groove.

Application:
 Destiné à recevoir les fraises et les fraises avec des rainures transversales.

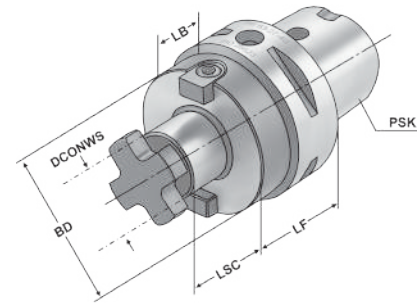

Bestell-Nr. Order no. Référence	PSK	DCONWS	TDCON	LF	LSC	LB	BD
C3.11.16	C3	16	h6	30	17	15	38
C4.11.16	C4	16	h6	35	17	15	38
C4.11.22	C4	22	h6	40	19	20	48
C5.11.16	C5	16	h6	35	17	15	38
C5.11.22	C5	22	h6	40	19	20	48
C5.11.27	C5	27	h6	40	21	20	58
C5.11.32	C5	32	h6	40	24	20	78
C6.11.16	C6	16	h6	35	17	13	38
C6.11.22	C6	22	h6	40	19	18	48
C6.11.27	C6	27	h6	40	21	18	58
C6.11.32	C6	32	h6	40	24	18	78
C6.11.40	C6	40	h6	45	27	23	88
C6.11.16.1	C6	16	h6	100	17	78	38
C6.11.22.1	C6	22	h6	100	19	78	48
C6.11.27.1	C6	27	h6	100	21	78	58

DCONWS = 40 Für große Planfräser mit vier zusätzlichen Gewindebohrungen nach DIN 2079.
 For large diameter face mill cutters with four additional threaded holes according to DIN 2079.
 Pour fraises à surfacer à grands diamètres avec 4 taraudages supplémentaires suivant DIN 2079.

Lieferumfang: Mit Mitnehmersteinen, Kreuzschraube und Zylinderkopfschraube nach DIN 912 für Fräser mit innerer Kühlmittelzufuhr.
Delivery: With drivers, cross head retaining screw and cylinder head retaining screw for cutters with central coolant.
Livraison: Avec tenon d entraînement, vis cruciforme et vis à têtes cylindrique suivant DIN 912 pour les fraises avec arrosage central.

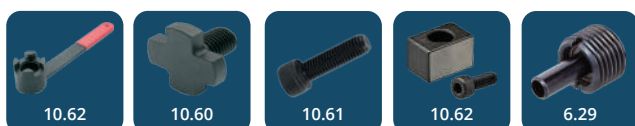

auf Druck und Zug

Quick change tapping chucks **with** length compensation on compression and expansion
 Mandrins de taraudage à changement rapide **avec** compensation longitudinale à la compression et traction



Verwendung:

Zur Aufnahme von Schnellwechsel-Einsätzen für Gewindebohrer.

Application:

For the chucking of quick change adaptors for taps.

Application:

Pour le serrage d'adapteurs portetarauds à changement rapide.

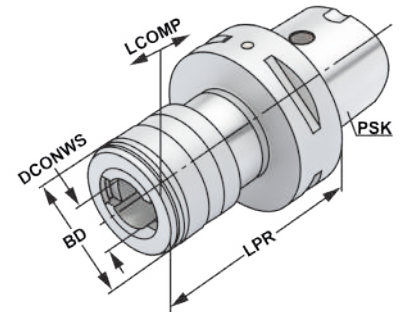

Bestell-Nr. Order no. Référence	PSK	Spannbereich Capacity Capacité	SZID	DCONWS	LPR	BD	LCOMP
C4.16.12	C4	M3 - M14	1	19	80	36	7,5
C4.16.20	C4	M5 - M22	2	31	110	53	12,5
C5.16.12	C5	M3 - M14	1	19	80	36	7,5
C5.16.20	C5	M5 - M22	2	31	115	53	12,5
C6.16.12	C6	M3 - M14	1	19	90	36	7,5
C6.16.20	C6	M5 - M22	2	31	120	53	12,5
C6.16.36	C6	M14 - M36	3	48	170	78	20

Hinweis: Für Bearbeitungszentren ohne Synchronspindel.
Note: For machining centres without synchronous spindle.
Observation: Pour centres d'usinage sans broche synchrone.



10.42



10.43



10.48



10.49



10.50



6.29

Boring bar blanks
Barres d'alésage



Verwendung:
Zur Herstellung von Sonderwerkzeugen.
Application:
For the manufacturing of special tools.
Application:
Pour la fabrication d'outils spéciaux.

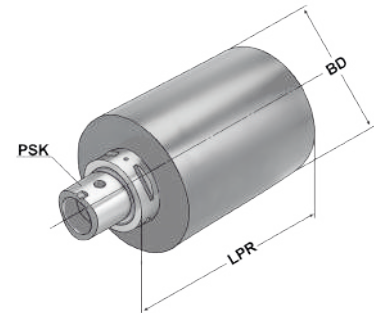

ISO
26623

Bestell-Nr. Order no. Référence	PSK	BD	LPR
C3.17.32	C3	32	90
C3.17.60	C3	60	90
C4.17.40	C4	40	120
C4.17.80	C4	80	120
C5.17.50	C5	50	150
C5.17.95	C5	95	150
C6.17.63	C6	63	180
C6.17.120	C6	120	180

Ausführung: Kegel und Bund gehärtet und geschliffen. Schaft weich zur weiteren Bearbeitung.
Version: *Cone and flange hardened and grinded. Soft body for later processing.*
Version: Cône et collerette durcis et rectifiés. Corps doux pour un usinage ultérieur.



Hydraulic expansion chucks Mandrins expansibles hydrauliques



Verwendung:

Zur Aufnahme von Werkzeugen mit Zylinderschaft nach DIN 1835 Form A+B+E und DIN 6535 Form HB+HE (größer Ø 20 mm nur mit Reduzierung).

Application:

For mounting straight-shank tools acc. DIN 1835 form A+B+E and DIN 6535 form HB+HE (larger than Ø 20 mm only with reduction sleeve).

Application:

Pour le serrage d'outils avec queue cylindrique suivant DIN 1835 forme A+B+E et DIN 6535 forme HB+HE (à partir de Ø 20 mm seulement avec réduction).

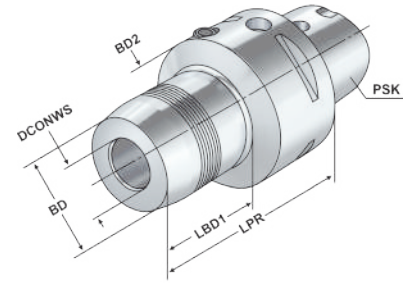

ISO 26623 ≤ 3µm G2.5 25.000 min⁻¹ H4

13.04

Bestell-Nr. Order no. Référence	PSK	DCONWS	LPR	BD	BD2	LSCX	ADJRGA	LBD1	DRVS	THID
C4.H12	C4	12	70	32	26	47	10	35	5	M8x1
C4.H20	C4	20	90	42	42	52	10	45	5	M10x1
C5.H12	C5	12	75	32	26	47	10	35	5	M8x1
C5.H20	C5	20	85	42	42	52	10	45	5	M10x1
C6.H12	C6	12	80	32	26	47	10	35	5	M8x1
C6.H20	C6	20	85	42	42	52	10	45	6	M10x1
C6.H32	C6	32	100	26	34	37	10	45	6	M12x1

LSCX = Einspannlänge, max. ADJRGA = Verstellweg, max.
 LSCX = Clamping depth, max. ADJRGA = Length adjustment range, max.
 LSCX = Profondeur d'insertion, max. ADJRGA = Course de réglage, max.

Lieferumfang: Ohne Spannschlüssel
 Delivery: Without wrench
 Livraison: Sans clé de serrage

6



Milling arbors for screw-in cutters

Porte-fraises pour fraises à queue fileté



Verwendung:
Zur Aufnahme von Einschraubfräser mit Gewinde.

Application:
For mounting screw-in cutters with thread.

Application:
Pour le serrage de fraises à queue fileté.

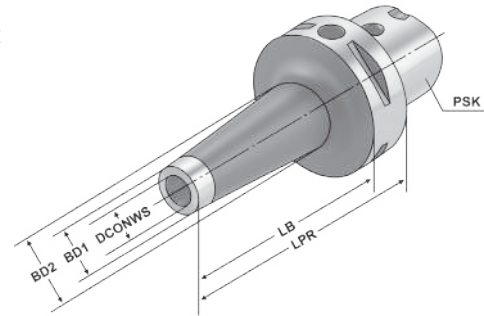

Bestell-Nr. Order no. Référence	PSK	THSZWS	DCONWS	BD1	BD2	LPR	LB
C6.06.08	C6	M8	8,5	13	23	105	75
C6.06.10	C6	M10	10,5	18	25	105	75
C6.06.12	C6	M12	12,5	21	31	105	75
C6.06.16	C6	M16	17	29	34	105	75

Empfohlenes Anzugsmoment
Recommended tightening torques
Torques de serrage recommandés

M6	10 Nm
M8	25 Nm
M10	40 Nm
M12	60 Nm
M16	50 Nm





Shrink chucks 4,5°
Mandrins de frettage 4,5°



Verwendung:
Zur Aufnahme von Werkzeugen mit Zylinderschaft.

Application:
For mounting straight-shank tools.

Application:
Pour le serrage d'outils avec queue cylindrique.

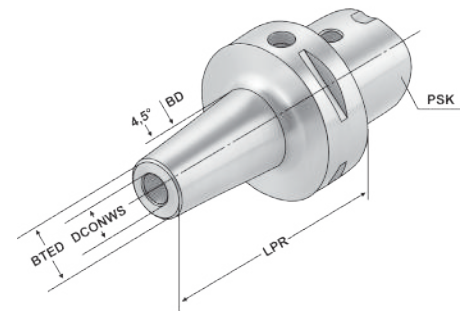

Bestell-Nr. Order no. Référence	PSK	DCONMS	TDCON	LPR	BTED	BD	LSCN	LSCX	ADJRGA	THID
C3.70.06	C3	6	h6	60	21	27	26	36	10	M8x1
C3.70.08	C3	8	h6	107	21	27	26	36	10	M8x1
C3.70.10	C3	10	h6	95	24	32	31	41	10	M10x1
C3.70.12	C3	12	h6	84	24	32	37	47	10	M10x1
C4.70.06	C4	6	h6	75	21	27	26	36	10	M8x1
C4.70.08	C4	8	h6	75	21	27	26	36	10	M8x1
C4.70.10	C4	10	h6	75	24	32	31	41	10	M10x1
C4.70.12	C4	12	h6	75	24	32	37	47	10	M10x1
C4.70.14	C4	14	h6	80	27	34	37	47	10	M10x1
C4.70.16	C4	16	h6	80	27	34	40	50	10	M10x1
C4.70.18	C4	18	h6	80	33	42	40	50	10	M10x1
C4.70.20	C4	20	h6	85	33	42	42	52	10	M10x1
C5.70.06	C5	6	h6	75	21	27	26	36	10	M8x1
C5.70.08	C5	8	h6	75	21	27	26	36	10	M8x1
C5.70.10	C5	10	h6	75	24	32	31	41	10	M10x1
C5.70.12	C5	12	h6	75	24	32	37	47	10	M10x1
C5.70.14	C5	14	h6	80	27	34	37	47	10	M10x1
C5.70.16	C5	16	h6	80	27	34	40	50	10	M10x1
C5.70.18	C5	18	h6	80	33	42	40	50	10	M10x1
C5.70.20	C5	20	h6	85	33	42	42	52	10	M10x1
C5.70.25	C5	25	h6	90	44	53	48	58	10	M10x1

LSCX = Einspannlänge, max. ADJRGA = Verstellweg, max.
LSCX = Clamping depth, max. ADJRGA = Length adjustment range, max.
LSCX = Profondeur d'insertion, max. ADJRGA = Course de réglage, max.

Für Ø 3, 4 und 5 mm nur Hartmetallschäfte verwenden
For Ø 3, 4 and 5 mm only solid carbide tool shanks must be used
Pour Ø 3, 4 et 5 mm il faut seulement utiliser de queues d'outils carbures de type HM

Hinweis: Aufnahmen für Induktiv-, Kontakt- und Heißluftschumpfgeräte geeignet.
Schafftoleranz bei Ø 3, 4 und 5 mm = h4, bei Ø 6 - Ø 32 mm = h6

Note: Toolholders suitable for induction-, contact- and hot air shrink units.
Ø 3, 4, 5 with h4-tolerance and Ø 6 - Ø 32 with h6-tolerance

Observation: Porte-outils convenables pour machines à fretter par induction,
par contact, ou par air chaud.
Ø 3, 4, 5 avec h4-tolerance et Ø 6 - Ø 32 avec h6-tolerance



Shrink chucks 4,5°
Mandrins de frettage 4,5°



Verwendung:
Zur Aufnahme von Werkzeugen mit Zylinderschaft.

Application:
For mounting straight-shank tools.

Application:
Pour le serrage d'outils avec queue cylindrique.

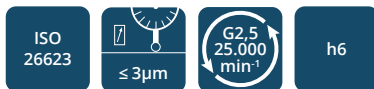
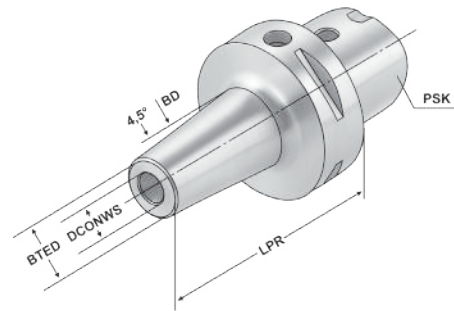

Bestell-Nr. Order no. Référence	PSK	DCONMS	TDCON	LPR	BTED	BD	LSCN	LSCX	ADJRGA	THID
C6.70.03	C6	3	h4	80	10	20	10	10	10	M6x1
C6.70.04	C6	4	h4	80	11	20	10	10	10	M6x1
C6.70.06	C6	6	h6	80	21	27	26	36	10	M8x1
C6.70.08	C6	8	h6	80	21	27	26	36	10	M8x1
C6.70.10	C6	10	h6	80	24	32	31	41	10	M10x1
C6.70.12	C6	12	h6	80	24	32	37	47	10	M10x1
C6.70.14	C6	14	h6	85	27	34	37	47	10	M10x1
C6.70.16	C6	16	h6	85	27	34	40	50	10	M10x1
C6.70.18	C6	18	h6	85	33	42	40	50	10	M10x1
C6.70.20	C6	20	h6	85	33	42	42	52	10	M10x1
C6.70.25	C6	25	h6	90	44	53	48	58	10	M10x1
C6.70.32	C6	32	h6	95	44	53	52	62	10	M10x1
C6.70.06.1	C6	6	h6	120	21	27	26	36	10	M8x1
C6.70.08.1	C6	8	h6	120	21	27	26	36	10	M8x1
C6.70.10.1	C6	10	h6	120	24	32	31	41	10	M10x1
C6.70.12.1	C6	12	h6	120	24	32	37	47	10	M10x1
C6.70.16.1	C6	16	h6	120	27	34	40	50	10	M10x1
C6.70.20.1	C6	20	h6	120	33	42	42	52	10	M10x1
C6.70.25.1	C6	25	h6	120	44	53	48	58	10	M10x1
C6.70.32.1	C6	32	h6	120	44	53	52	62	10	M10x1
C6.70.06.2	C6	6	h6	160	21	27	26	36	10	M8x1
C6.70.08.2	C6	8	h6	160	21	27	26	36	10	M8x1
C6.70.10.2	C6	10	h6	160	24	32	31	41	10	M10x1
C6.70.12.2	C6	12	h6	160	24	32	37	47	10	M10x1
C6.70.16.2	C6	16	h6	160	27	34	40	50	10	M10x1
C6.70.20.2	C6	20	h6	160	33	42	42	52	10	M10x1

LSCX = Einspannlänge, max. ADJRGA = Verstellweg, max.
LSCX = Clamping depth, max. ADJRGA = Length adjustment range, max.
LSCX = Profondeur d'insertion, max. ADJRGA = Course de réglage, max.

Für Ø 3, 4 und 5 mm nur Hartmetallschäfte verwenden
For Ø 3, 4 and 5 mm only solid carbide tool shanks must be used
Pour Ø 3, 4 et 5 mm il faut seulement utiliser de queues d'outils carbures de type HM

Hinweis: Aufnahmen für Induktiv-, Kontakt- und Heißluftschrimpferäte geeignet.
Schafttoleranz bei Ø 3, 4 und 5 mm = h4, bei Ø 6 - Ø 32 mm = h6

Note: Toolholders suitable for induction-, contact- and hot air shrink units.
Ø 3, 4, 5 with h4-tolerance and Ø 6 - Ø 32 with h6-tolerance

Observation: Porte-outils convenables pour machines à fretter par induction,
par contact, ou par air chaud.
Ø 3, 4, 5 avec h4-tolerance et Ø 6 - Ø 32 avec h6-tolerance





zum Spannen von HM und HSS Werkzeugschäften

Shrink chucks 4,5° for mounting of solid carbide and HSS-tool shanks

Mandrins de frettage 4,5° pour le serrage de queues d'outils carbures de type HM et HSS



Verwendung:
Zur Aufnahme von Werkzeugen mit Zylinderschaft.

Application:
For mounting straight-shank tools.

Application:
Pour le serrage d'outils avec queue cylindrique.

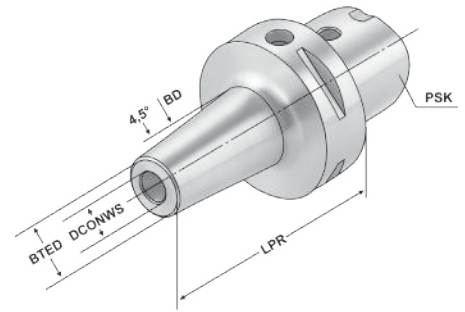

Bestell-Nr. Order no. Référence	PSK	DCONWS	TDCON	LPR	BTED	BD2	LSCN	LSCX	ADJRGA	THID
C6.70.06.K	C6	6	h6	80	16	27	22	36	10	M8x1
C6.70.08.K	C6	8	h6	80	21	27	26	36	10	M8x1
C6.70.10.K	C6	10	h6	80	24	32	31	41	10	M8x1
C6.70.12.K	C6	12	h6	80	24	32	36	46	10	M10x1
C6.70.16.K	C6	16	h6	85	27	34	39	49	10	M10x1
C6.70.20.K	C6	20	h6	85	33	42	41	51	10	M10x1
C6.70.25.K	C6	25	h6	90	44	53	47	57	10	M10x1
C6.70.32.K	C6	32	h6	90	44	53	51	61	10	M10x1

LSCX = Einspannlänge, max. ADJRGA = Verstellweg, max.
 LSCX = Clamping depth, max. ADJRGA = Length adjustment range, max.
 LSCX = Profondeur d'insertion, max. ADJRGA = Course de réglage, max.

Für Ø 3, 4 und 5 mm nur Hartmetallschäfte verwenden
For Ø 3, 4 and 5 mm only solid carbide tool shanks must be used
 Pour Ø 3, 4 et 5 mm il faut seulement utiliser de queues d'outils carbures de type HM

Hinweis: Aufnahmen für Induktiv-, Kontakt- und Heißluftschumpfgeräte geeignet.
 Schafttoleranz bei Ø 3, 4 und 5 mm = h4, bei Ø 6 - Ø 32 mm = h6

Note: *Toolholders suitable for induction-, contact- and hot air shrink units.*
 Ø 3, 4, 5 with h4-tolerance and Ø 6 - Ø 32 with h6-tolerance

Observation: Porte-outils convenables pour machines à fretter par induction,
 par contact, ou par air chaud.
 Ø 3, 4, 5 avec h4-tolerance et Ø 6 - Ø 32 avec h6-tolerance



CNC-Drill chucks for clockwise and counter clockwise rotation
Mandrins de perçage CNC pour rotation gauche-droite



Verwendung:
Zur Aufnahme von Werkzeugen mit Zylinderschaft.
Application:
For mounting tools with straight shanks.
Application:
Pour le serrage d'outils avec queue cylindrique.

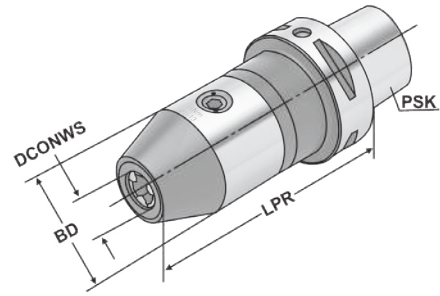

Bestell-Nr. Order no. Référence	PSK	DCONWS Spannbereich Capacity Capacité	LPR	BD	DRVS
C6.15.13	C6	1,0 – 13	112	50	6
C6.15.16	C6	2,5 – 16	117	50	6

Mit zentraler Kühlmittelzufuhr
With centre coolant
Avec alimentation de liquide de refroidissement par la centre

- Hinweis:** Hohe Präzision und Rundlaufgenauigkeit von $\leq 0,03$ mm. Sichere Spannung des Werkzeuges durch mechanische Spannkraftverstärkung. Kein selbständiges Lösen der Spannung während der Bearbeitung bei Links- oder Rechtslauf, sowie bei Spindelstop. Spannen und Lösen mit Sechskantschlüssel.
- Note:** High precision and accurate concentricity of ≤ 0.03 mm. Secure gripping of the tool through mechanical amplification of the clamping force. No automatic slacking of the clamping force while machining with either clockwise or counter clockwise rotation or on spindle stop. Clamping and releasing effected by means of an Allen wrench.
- Observation:** Précision élevée et exactitude de circularité de $\leq 0,03$ mm. Serrage sûr de l'outil grâce à l'amplification de la force de serrage. Pas de desserrage intempestif en cours d'usinage lors de la rotation la gauche ou la droite, de même qu'en cas d'arrêt de la broche. Serrage et desserrage en utilisant un clé sur à fourche.

Lieferumfang: Ohne Spannschlüssel
Delivery: Without wrench
Livraison: Sans clé de serrage

Gewuchtete Ausführung



Balanced type
Type équilibré

Bestell-Nr. Order no. Référence	Abmessung Size Dimension
---------------------------------------	--------------------------------

- Wuchten auf G 2,5 von vorgewuchteten Kemmler-Werkzeugen**
Balancing at G 2.5 of pre-balanced Kemmler-tools
Équilibrage sur G 2,5 d'outils Kemmler pré-équilibrés
- W25 **Ohne Wuchtprotokoll**
Without balancing report
Sans protocole d'équilibrage
- W25.2 **Mit Wuchtprotokoll**
With balancing report
Avec protocole d'équilibrage
- Wuchten von nicht vorgewuchteten Werkzeugen**
Balancing of unbalanced tools
Équilibrage d'outils non-équilibrés
- W25.1 **Ohne Wuchtprotokoll**
Without balancing report
Sans protocole d'équilibrage





Boring holders for drills with indexable inserts form E1
Portes forets pour forets à plaquettes réversibles forme E1



Verwendung:

Zur Aufnahme von allen nach DIN 6595 genormten Vollbohrern mit Zylinderschaft.

Application:

For all solid drills with cylindrical shank according to DIN 6595.

Application:

Pour le serrage de forets à queue cylindrique suivant DIN 6595.

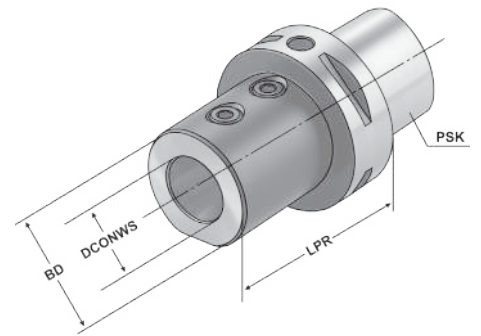

ISO 26623	≤ 4µm	G6.3 15.000 min ⁻¹	ISO 9766	E1	H6
-----------	-------	-------------------------------	----------	----	----

Bestell-Nr. Order no. Référence	PSK	DCONWS	TDCON	LPR	BD
C6.51.20	C6	20	H6	70	40
C6.51.25	C6	25	H6	70	45
C6.51.32	C6	32	H6	75	52
C6.51.40	C6	40	H6	85	60

6

Lieferumfang: Mit Spannschrauben
Delivery: With clamping screws
Livraison: Avec vis de serrage



Boring bar holders form E2 - Clamping possible on both sides

Porte-outils pour barres d'alésage forme E2 - Possibilité de serrage des deux côtés



Verwendung:
Für Innenbearbeitung mit Bohrstangen.
Application:
For internal machining with boring bars.
Application:
Pour l'usinage intérieur avec barres d'alésage.

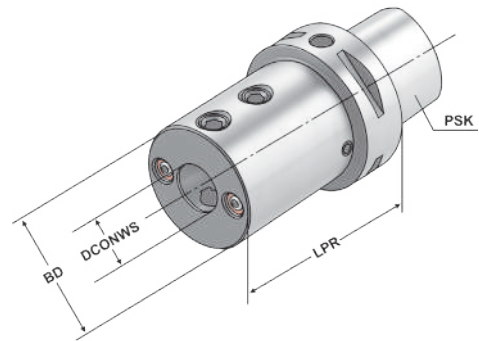

ISO 26623 ≤ 4µm G6.3 15.000 min⁻¹ E2 H6

Bestell-Nr. Order no. Référence	PSK	DCONWS	TDCON	LPR	BD
C6.52.12	C6	12	H6	80	44
C6.52.16	C6	16	H6	80	48
C6.52.20	C6	20	H6	85	52
C6.52.25	C6	25	H6	85	57
C6.52.32	C6	32	H6	90	64
C6.52.40	C6	40	H6	90	74

6

Ausführung: Mit einstellbaren Kugelspritzdüsen, verschließbar für Werkzeuge mit innerer Kühlmittelzufuhr
Version: With adjustable ball spray nozzles, closable for tools with internal coolant supply
Version: Avec buses d'injection à billes réglables, obturables pour les outils avec arrosage interne

Lieferumfang: Mit Spannschrauben
Delivery: With clamping screws
Livraison: Avec vis de serrage



Spannmöglichkeit beidseitig
Clamping possible on both sides
Possibilité de serrage des deux côtés

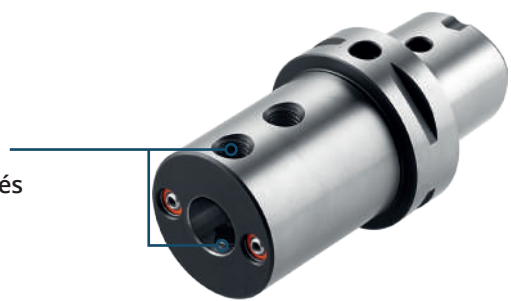

10.67 6.29 10.72

Reducing adapter for adaption from ISO to PSC (ISO 7388-1 to ISO 26623-1)
 Douille de réduction pour adaptation de ISO à PSC (ISO 7388-1 à ISO 26623-1)



Verwendung:
 Zur Adaption von SK auf PSK
 (ISO 7388-1 auf ISO 26623-1)
Application:
 For adaption from ISO to PSC
 (ISO 7388-1 to ISO 26623-1)
Application:
 Pour adaptation de ISO à PSC
 (ISO 7388-1 à ISO 26623-1).

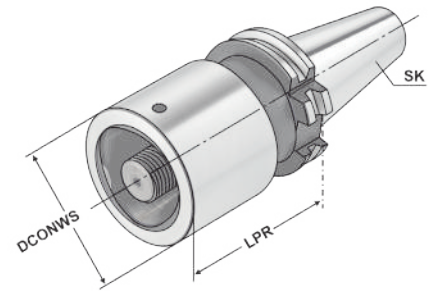

ISO 7388-1 Form AD $\leq 3\mu\text{m}$ G6.3 15.000 min⁻¹ RFID Chip ISO 26623

Bestell-Nr. Order no. Référence	SK	Typ	DCONWS	LPR	TQX	THID
402.09.C3	SK 40	PSK C3	32	30	50	M12x1,5
402.09.C4	SK 40	PSK C4	40	40	50	M14x1,5
402.09.C5	SK 40	PSK C5	50	50	50	M16x1,5
402.09.C6	SK 40	PSK C6	63	90	70	M20x2,0

6

Ausführung:

Adapter SK / PSK mit Axialspannung. Innen und außen geschliffen. Das im PSK-Werkzeughalter für Kühlmittel-Rohre vorgesehene Innengewinde wird mit der im Adapter integrierten Zylinderkopfschraube verschraubt. Spannschraube durchbohrt, somit ist das System für Innenkühlung geeignet. Passend für Werkzeugaufnahmen mit Polygonschaft (PSC/PSK) ISO 26623-1.

Version:

Adapters SK / PSK with axial clamping. Ground internally and externally. The internal thread provided for the coolant tube in the PSC toolholder is plugged with the socket-head screw incorporated in the adapter. The clamping screw incorporates a through hole, so the system is suitable for through-coolant feed. Suitable for tool arbor with polygonal shank (PSC) - ISO 26623-1.

Exécution:

Adaptateurs SK / PSK Tension axiale. Intérieur et extérieur rectifiés. Le filetage intérieur prévu pour les conduits d'arrosage dans le porte-outils PSC est vissé à l'aide de la vis à tête cylindrique intégrée dans l'adaptateur. Système adapté à l'arrosage interne grâce à la vis de serrage percée. Pour la réception d'outils PSK ISO 26623-1.

Lieferumfang: Mit Spannschraube
Delivery: Clamping screw
Livraison: Avec vis de serrage



Reducing adapter for adaption from HSK to PSC (ISO 12164 to ISO 26623-1)
 Douille de réduction pour adaptation de HSK à PSC (ISO 12164 à ISO 26623-1)



Verwendung:
 Zur Adaption von HSK-A auf PSK
 (ISO 12164 auf ISO 26623-1)
Application:
 For adaption from HSK-A to PSC
 (ISO 12164 to ISO 26623-1)
Application:
 Pour adaptation de HSK-A à PSC
 (ISO 12164 à ISO 26623-1).

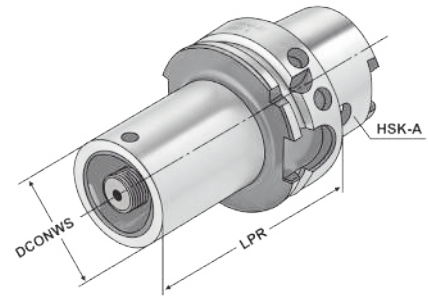

ISO 12164	Form A	$\leq 3\mu\text{m}$	G6.3 15,000 min ⁻¹	RFID Chip	ISO 26623
-----------	--------	---------------------	-------------------------------------	-----------	-----------

Bestell-Nr. Order no. Référence	HSK	Typ	DCONWS	LPR	TQX	THID
A63.09.C3	HSK 63	PSK C3	32	75	50	M12x1,5
A63.09.C4	HSK 63	PSK C4	40	80	50	M14x1,5
A63.09.C5	HSK 63	PSK C5	50	90	50	M16x1,5

6

Ausführung:

Adapter HSK / PSK mit Axialspannung. Innen und außen geschliffen. Das im PSK-Werkzeughalter für Kühlmittel-Rohre vorgesehene Innengewinde wird mit der im Adapter integrierten Zylinderkopfschraube verschraubt. Spannschraube durchbohrt, somit ist das System für Innenkühlung geeignet. Passend für Werkzeugaufnahmen mit Polygonschaft (PSC/PSK) ISO 26623-1.

Version:

Adapters HSK / PSK with axial clamping. Ground internally and externally. The internal thread provided for the coolant tube in the PSC toolholder is plugged with the socket-head screw incorporated in the adapter. The clamping screw incorporates a through hole, so the system is suitable for through-coolant feed. Suitable for tool arbor with polygonal shank (PSC) - ISO 26623-1.

Exécution:

Adaptateurs HSK / PSK Tension axiale. Intérieur et extérieur rectifiés. Le filetage intérieur prévu pour les conduits d'arrosage dans le porte-outils PSC est vissé à l'aide de la vis à tête cylindrique intégrée dans l'adaptateur. Système adapté à l'arrosage interne grâce à la vis de serrage percée. Pour la réception d'outils PSK ISO 26623-1.

Lieferumfang: Mit Spannschraube
Delivery: Clamping screw
Livraison: Avec vis de serrage





Multi-turning-toolholders with internal coolant Mandrins tournant multi-usage avec arrosage interne



Verwendung:

- für Klemmhalter mit Kühlmittelzufuhr direkt zur Schneide
- für ISO-Klemmhalter mit Pratzeklemmung zur optimalen Kühlung der Schneide
- Kühlmitteldruck bis 100 bar

Application:

- for clamping holders with coolant channels directly to the cutting edge
- for ISO-clamping holders with claw clamping for best possible coolant supply
- coolant pressure up to 100 bar

Application:

- pour porte-outils avec alimentation en liquide d'arrosage directement sur l'arête de coupe
- pour porte-outils ISO avec pinces à griffes pour un arrosage optimal du tranchant
- Pression du liquide d'arrosage jusqu'à 100 bar

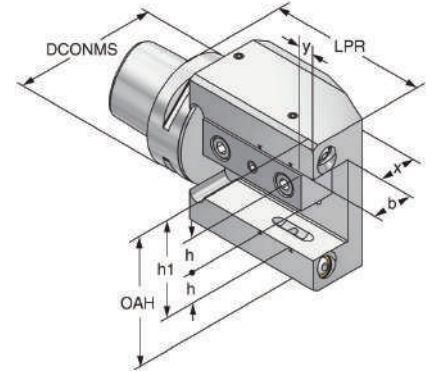

ISO 26623

6

Bestell-Nr. Order no. Référence	Abmessung Size Dimension	PSK	LPR	h/b	OAH	h1	x	y
C6.81.20	C6x20x112	C6	112	20	80	40	31,5	10
C6.81.25	C6x25x112	C6	112	25	90	45	31,5	10



Ausführung:

- Ein Drehhalter - vier Einsatzmöglichkeiten:
Links - rechts - vorkopf - überkopf.
B1- B2 - B3 - B4.
Spritzdüsen verschließbar für Werkzeuge mit innerer Kühlmittelzufuhr.

Version:

- One turning toolholder - four possibilities:
Left - right - forehead - overhead.
B1- B2 - B3 - B4.
Coolant nozzles lockable for tools with internal coolant.

Exécution:

- Un mandrin tournant - quatre possibilités d'utilisation:
Gauche - droite - front - au-dessus de la tête.
B1- B2 - B3 - B4.
Gicleurs verrouillables pour outils avec arrosage interne.

Lieferumfang: Ohne die abgebildeten Schneidwerkzeuge
Delivery: Without the illustrated cutting tools
Livraison: Sans les outils de coupe illustrés



Multi-turning-toolholders 45° with internal coolant
Mandrins tournant multi-usage 45° avec arrosage interne

**Verwendung:**

- für Klemmhalter mit Kühlmittelzufuhr direkt zur Schneide
- für ISO-Klemmhalter mit Prätzenklammung zur optimalen Kühlung der Schneide
- Kühlmitteldruck bis 100 bar

Application:

- for clamping holders with coolant channels directly to the cutting edge
- for ISO-clamping holders with claw clamping for best possible coolant supply
- coolant pressure up to 100 bar

Application:

- pour porte-outils avec alimentation en liquide d'arrosage directement sur l'arête de coupe
- pour porte-outils ISO avec pinces à griffes pour un arrosage optimal du tranchant
- Pression du liquide d'arrosage jusqu'à 100 bar

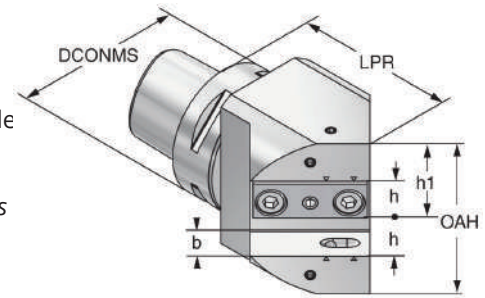

ISO
26623

6

Bestell-Nr. Order no. Référence	Abmessung Size Dimension	PSK	LPR	h/b	OAH	h1
C6.83.20	C6x20x45°	C6	93	20	80	40
C6.83.25	C6x25x45°	C6	97	25	90	45



Lieferumfang: Ohne die abgebildeten Schneidwerkzeuge
Delivery: Without the illustrated cutting tools
Livraison: Sans les outils de coupe illustrés

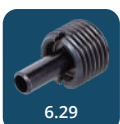

6.29

Test arbors
Mandrins de contrôle



Verwendung:
Zur Abnahme von Werkzeugmaschinen gemäß ISO-Empfehlung R230 oder zur Überprüfung der Werkzeugspindel.

Application:
For the inspection of machine tools according to ISO recommendation R230 or for testing the tool spindle.

Application:
Pour l'inspection de machine-outils suite à la recommandation ISO R230 ou pour la vérification de la broche.

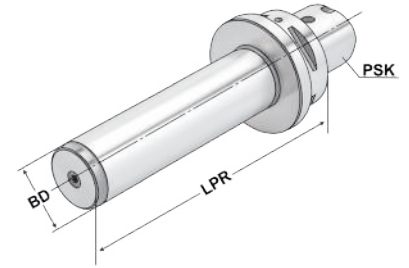

Bestell-Nr. Order no. Référence	PSK	LPR	BD	Toleranz Tolerance Tolérance	max. Rundlaufabweichung max. concentricity deviation Faux-rond max.
C3.18.20	C3	180	20	0,005	0,005
C4.18.32	C4	180	32	0,005	0,005
C5.18.32	C5	180	32	0,005	0,005
C6.18.40	C6	182	40	0,005	0,005
C6.18.40.352	C6	352	40	0,005	0,005

Lieferumfang: Auslieferung mit Prüfprotokoll
Delivery: Delivery with test certificate
Livraison: Livraison avec rapport d'essais

6

Holzkasten für Kontrolldorne

Wooden box for test arbors
Coffret en bois pour mandrins de contrôle



Verwendung:
Zur Aufbewahrung von Kontrolldornen.

Application:
For the storage of test arbors.

Application:
Pour la conservation de mandrins de contrôle.



Bestell-Nr. Order no. Référence	Abmessung Size Dimension	für Kegelgrößen for cones pour cônes
701.18	460 × 130 × 115	SK 30 / 40 / 50 / C3 / C4 / C5 / C6

Universal ball bearing tightening fixture
 Bloc de montage universel avec palier à billes



Verwendung:

Für einfaches und sicheres Klemmen von Werkzeugaufnahmen am Bund mittels Rollen zum Montieren und Demontieren von Schneidwerkzeugen. Reibschlüssig, daher selbstklemmend und ideal für HSK Formen E und F sowie Polygonschaft Aufnahmen.

Application:

For easy and reliable clamping of tool arbors at the collar using rollers to mount and remove cutting tools – friction lock is self-clamping and ideal for HSK forms E and F, and also polygon shank arbors.

Application:

Pour le serrage simple et sûr de porte-outils au niveau de la collerette à l'aide de galets pour le montage et le démontage d'outils de coupe – entraînement par friction, autoserrant.

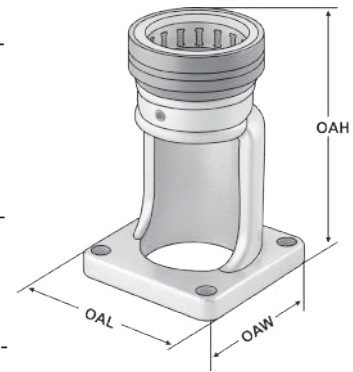

Bestell-Nr. Order no. Référence	Abmessung Size Dimension	OAL	OAW	OAH
707.1.032	C3 - HSK A32 - C32 - E32 - F32	110	110	165
707.1.040	C4 - HSK A40 - C40 - E40 - F40	110	110	165
707.1.050	C5 - HSK A50 - C50 - E50 - F50 - SK30	110	110	165
707.1.063	C6 - HSK A63 - C63 - E63 - F63 - BT40	110	110	172
707.1.080	C8 - HSK A80 - C80 - E80 - F80	160	160	215

Coolant tubes
Canules de lubrification



Verwendung:
Zur zentralen Übergabe von Kühlmittel bei PSK-Werkzeugaufnahmen.

Application:
For the coolant supply through the centre of PSC toolholders.

Application:
Pour l'arrosage centrale de porte-outils PSC.

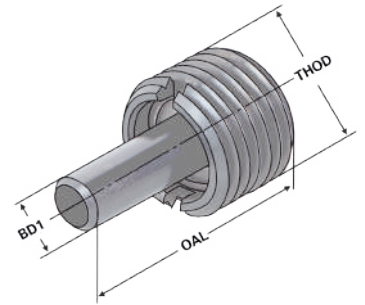

ISO
26623

Bestell-Nr. Order no. Référence	PSK	THOD	BD1	OAL
C3.700	C3 PSK 32	M12 x 1,5	5	22,4
C4.700	C4 PSK 40	M14 x 1,5	6	25,2
C5.700	C5 PSK 50	M16 x 1,5	7	28,3
C6.700	C6 PSK 63	M20 x 2	8	31,0
C8.700	C8 PSK 80	M20 x 2	10	31,5

6

Hinweis: Die Kühlmittelübergabeeinheit sollte unter Verwendung von Loctite® 542 fixiert werden.
Note: *The coolant transfer unit should be fixed using Loctite® 542*
Observation: L'unité de transfert du liquide de refroidissement doit être fixée à l'aide de Loctite® 542.

Key for coolant tubes

Clés pour canules de lubrification



Verwendung:

Zum Montieren der Kühlmittelübergabeeinheiten in PSK-Werkzeugaufnahmen.

Application:

For mounting the coolant tubes in PSC toolholders.

Application:

Pour le montage de canules de lubrification dans des porte-outils PSC.

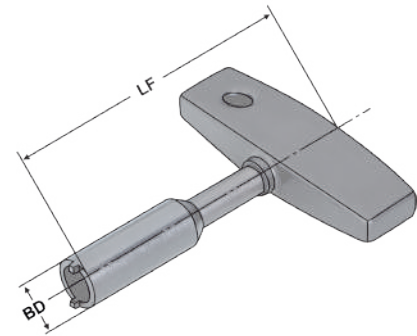

ISO
12164

Bestell-Nr.
Order no.
Référence

PSK

BD

LF

C3.701

C3 | PSK 32

8,5

115

C4.701

C4 | PSK 40

10,5

115

C5.701

C5 | PSK 50

14,5

115

C6.701

C6 | PSK 63

16,5

136

C8.701

C8 | PSK 80

18,5

136

WERKZEUGAUFNAHMEN

TOOLHOLDERS

PORTE-OUTILS

DIN ISO 10889

DIN 69880 (VDI 3425)

HAAS BMT 65

DIN ISO 10889

HAAS BMT 65

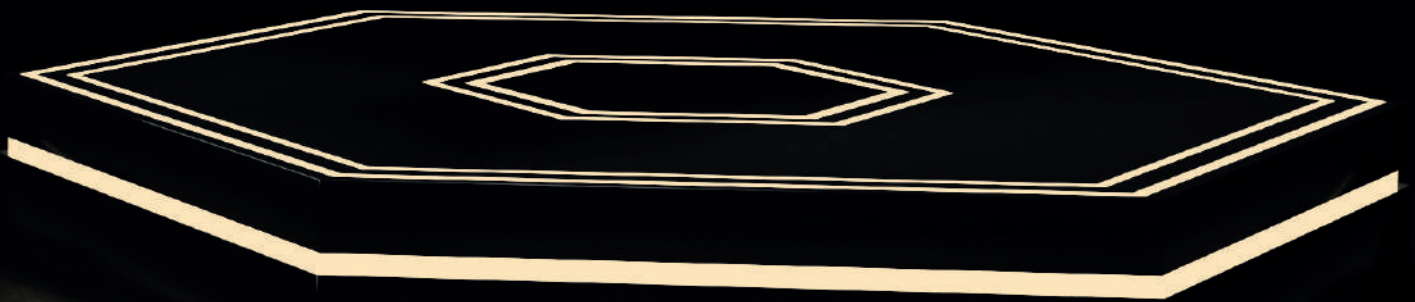
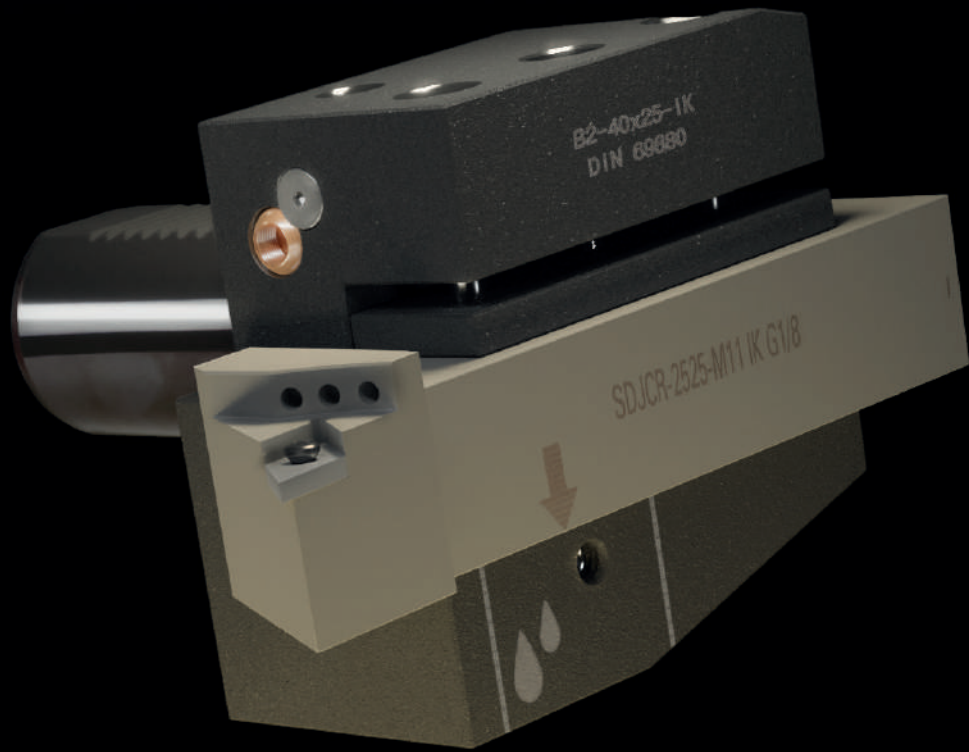

Toolholders DIN ISO 10889 (formerly DIN 69880 / VDI 3425)
 Porte-outils DIN ISO 10889 (l'ancien DIN 69880 / VDI 3425)

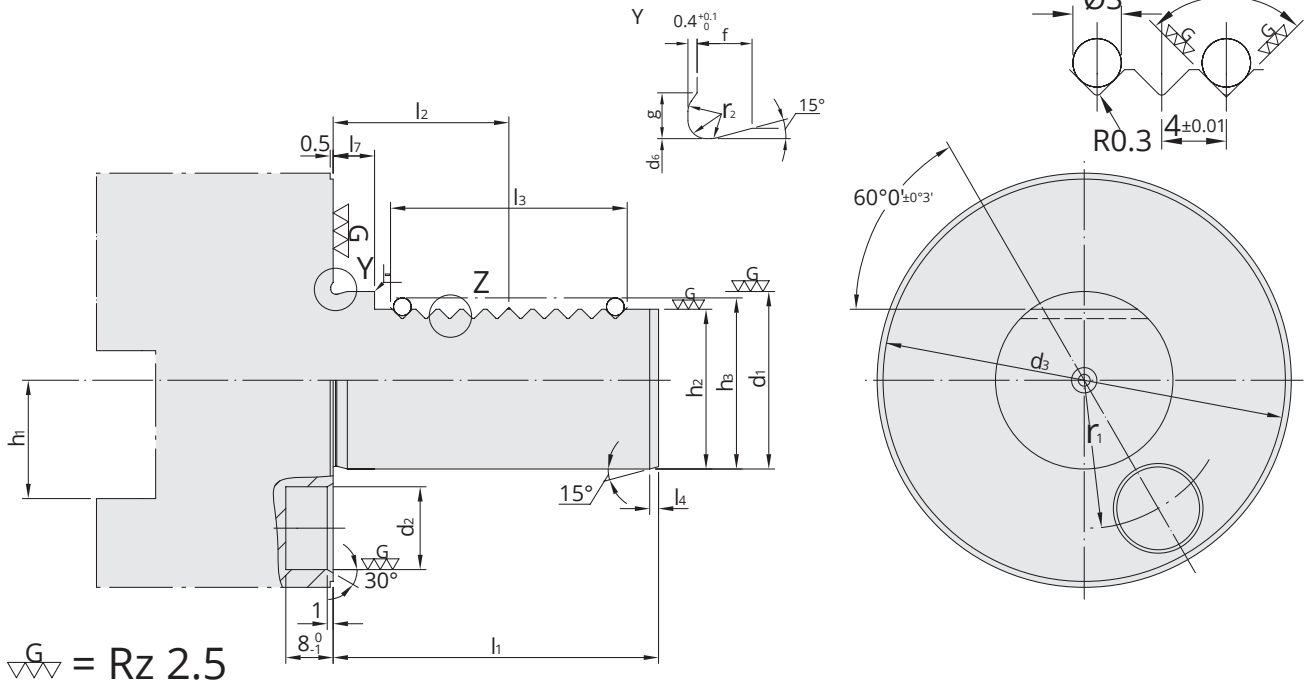

d_1 h_6	b	h_1 max.	d_2	d_3	h_2 $\pm 0,1$	r $\pm 0,02$	l_1 max.	l_2 $\pm 0,05$	l_3 max.	l_4 max.	l_5
16	42	12	8	40	15,0	14,5	32	12,7	16	2	3,5
20	52	16	10	50	18,0	18,0	40	21,7	24	2	7,0
25	60	16	10	58	23,5	21,0	48	21,7	24	2	7,0
30	70	20	14	68	27,0	25,0	55	29,7	40	2	7,0
40	85	25	14	83	36,0	32,0	63	29,7	40	3	7,0
50	100	32	16	98	45,0	37,0	78	35,7	48	3	8,0

Werkstoff: Legierter Einsatzstahl mit einer Zugfestigkeit im Kern von min. 950 N / mm². Einsatzgehärtet HRC 60 ± 2 (HV 700 ± 50), Härtetiefe 0,8 mm ± 0,2 mm, brüniert und präzisionsgeschliffen.

Ausführung: Mit innerer Kühlmittelzufuhr bzw. mit Gewindeanschluss für externe Kühlmittelzufuhr.

Material: Alloyed case-hardened steel, tensile core strength of min. 950 N / mm². Case hardened HRC 60 ± 2 (HV 700 ± 50), hardening depth 0.8 mm ± 0.2 mm, black-finished and precisely grinded.

Version: With internal coolant resp. with threaded connection for external coolant.

Matière: Acier de cémentation allié. Résistance à la traction dans le noyau de min 950 N / mm². Cémentation à HRC 60 ± 2 (HV 700 ± 50), profondeur de cémentation 0,8 mm ± 0,2 mm, bruni et rectifié précisément.

Version: Avec arrosage interne respectivement avec raccord fileté pour arrosage externe.

Werkzeugzuordnung für Scheibenrevolver

Tool assignment for disc turrets

Assignation des outils pour machines avec tourelle à disque

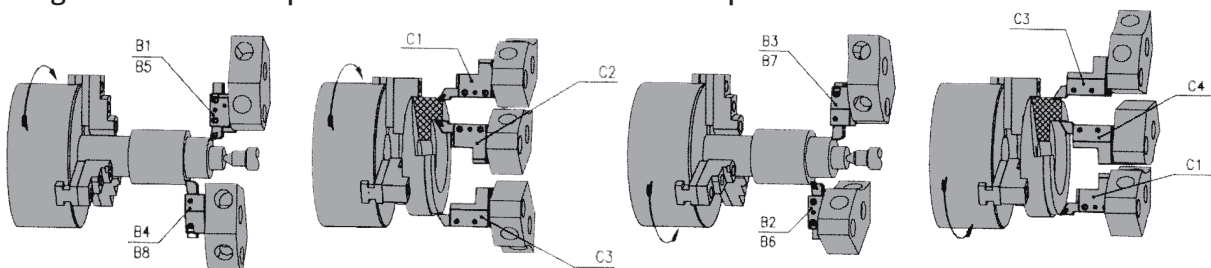

Einsatz von Werkzeughaltern bei linker Spindeldrehrichtung
 Application of tool holders with anti-clockwise spindle rotation
 Utilisation d'attachements avec la broche en sens anti-horaire

Einsatz von Werkzeughaltern bei rechter Spindeldrehrichtung
 Application of tool holders with clockwise spindle rotation
 Utilisation d'attachements avec la broche en sens horaire



 7.05 B1	 7.07 B2	 7.09 B3	 7.11 B4
 7.13 B5	 7.14 B6	 7.15 B7	 7.16 B8
 7.17 C1	 7.19 C2	 7.21 C3	 7.23 C4
 7.25 7.26 D1 D2	 7.27 7.28 AR AL	 7.29 E3	 7.30 E4
 7.31 E1	 7.32 E2	 7.33 E2	 7.36 E2
 7.37 E2	 7.39 F1	 7.40 Z2	 7.41 Z2
 7.43 E2	 7.45 F1	 7.47 7.48 A1 A2	 7.49 Z2
 7.50 - 7.57	 7.58 HAAS BMT 65	 7.58 HAAS BMT 65	 7.58 HAAS BMT 65
 7.58 HAAS BMT 65	 7.58 HAAS BMT 65	 7.58 HAAS BMT 65	 7.58 HAAS BMT 65





Verwendung:
Vorwiegend für Außenbearbeitung.
Zum Plan Einstechen.

Application:
Mainly for external machining.
For face machining.

Application:
Principalement pour usinage extérieur.
Pour carottage.

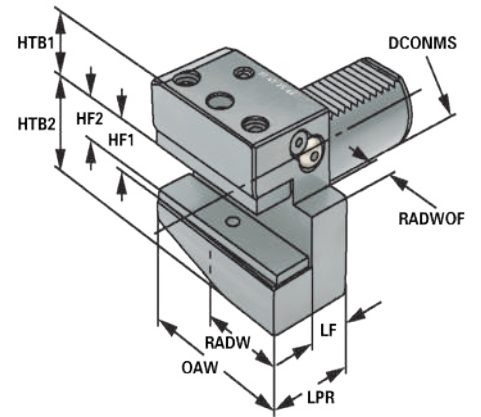

DIN ISO
10889

B1

Bestell-Nr. Order no. Référence	Abmessung Size Dimension	DCONMS	HF1	HF2	LPR	LF	OAW	RADW	RADWOF	HTB1	HTB2
169.31.12	B1 - 16 × 12 × 24	16	12	-	24	13	42	23	5	20	22
209.31.16	B1 - 20 × 16 × 30	20	16	12	30	16	55	30	7	25	30
259.31.16	B1 - 25 × 16 × 30	25	16	12	30	16	55	30	7	25	30
309.31.20	B1 - 30 × 20 × 40	30	24,5	20,5	40	22	70	35	10	23,5	42,5
409.31.25	B1 - 40 × 25 × 44	40	28	23	44	22	85	42,5	12,5	30	50
509.31.32	B1 - 50 × 32 × 55	50	33	26	55	30	100	50	16	35	60

Ausführung: Mit einstellbarer Kugelspritzdüse und Unterlegplatte
Version: With adjustable spray nozzle and shim
Version: Avec gicleur ajustable et semelle

7

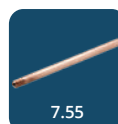
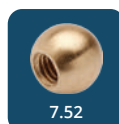



Radial toolholders form B1 right, short - for tools with internal coolant
 Porte-outils radials forme B1 droite, pour - outils avec arrosage interne



Verwendung:
 Vorwiegend für Außenbearbeitung.
 Zum Plan Einstechen.

Application:
 Mainly for external machining.
 For face machining.

Application:
 Principalement pour usinage extérieur.
 Pour carottage.

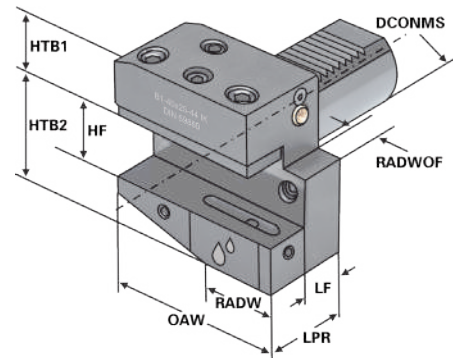

Bestell-Nr. Order no. Référence	Abmessung Size Dimension	DCONMS	HF	LPR	LF	OAW	RADW	RADWOF	HTB1	HTB2
309.31.20.IK	B1 - 30 × 20 × 40	30	20	40	22	70	35	10	28	38
409.31.25.IK	B1 - 40 × 25 × 44	40	25	44	22	85	42,5	12,5	32,5	48
509.31.32.IK	B1 - 50 × 32 × 55	50	32	55	30	100	50	16	35	60

Ausführung: Mit einstellbarer Kugelspritzdüse
Version: With adjustable spray nozzle
Version: Avec gicleur ajustable

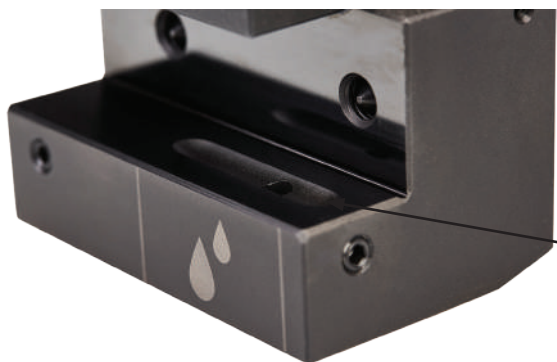

Übergabe für Kühlmittel
 Coolant supply
 Jonction d'arrosage

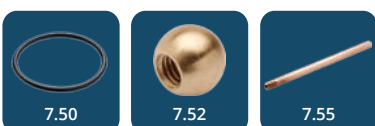



Verwendung:
Vorwiegend für Außenbearbeitung.
Zum Plan Einstechen.

Application:
Mainly for external machining.
For face machining.

Application:
Principalement pour usinage extérieur.
Pour carottage.

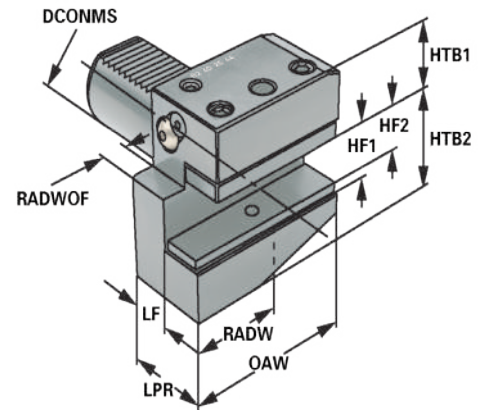

Bestell-Nr. Order no. Référence	Abmessung Size Dimension	DCONMS	HF1	HF2	LPR	LF	OAW	RADW	RADWOF	HTB1	HTB2
169.32.12	B2 - 16 × 12 × 24	16	12	-	24	13	42	23	5	20	22
209.32.16	B2 - 20 × 16 × 30	20	16	12	30	16	55	30	7	25	30
259.32.16	B2 - 25 × 16 × 30	25	16	12	30	16	55	30	7	25	30
309.32.20	B2 - 30 × 20 × 40	30	24,5	20,5	40	22	70	35	10	23,5	42,5
409.32.25	B2 - 40 × 25 × 44	40	28	23	44	22	85	42,5	12,5	30	50
509.32.32	B2 - 50 × 32 × 55	50	33	26	55	30	100	50	16	35	60

Ausführung: Mit einstellbarer Kugelspritzdüse und Unterlegplatte
Version: With adjustable spray nozzle and shim
Vérion: Avec gicleur ajustable et semelle



Radial toolholders form B2 left, short - for tools with internal coolant
 Porte-outils radials forme B2 gauche, court - pour outils avec arrosage interne



Verwendung:
 Vorwiegend für Außenbearbeitung.
 Zum Plan Einstechen.

Application:
 Mainly for external machining.
 For face machining.

Application:
 Principalement pour usinage extérieur.
 Pour carottage.

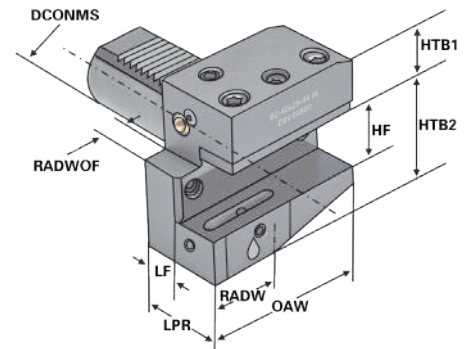

Bestell-Nr. Order no. Référence	Abmessung Size Dimension	DCONMS	HF	LPR	LF	OAW	RADW	RADWOF	HTB1	HTB2
309.32.20.IK	B2 - 30 × 20 × 40	30	20	40	22	70	35	10	28	38
409.32.25.IK	B2 - 40 × 25 × 44	40	25	44	22	85	42,5	12,5	32,5	48
509.32.32.IK	B2 - 50 × 32 × 55	50	32	55	30	100	50	16	35	60

Ausführung: Mit einstellbarer Kugelspritzdüse
Version: With adjustable spray nozzle
Version: Avec gicleur ajustable

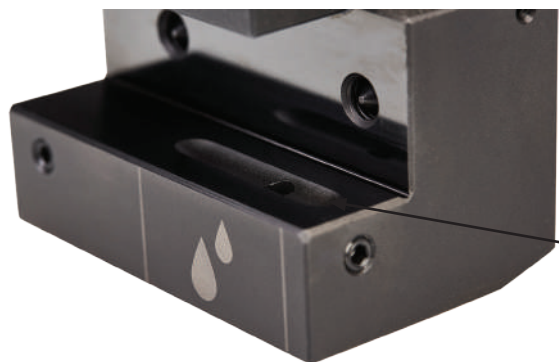

Übergabe für Kühlmittel
 Coolant supply
 Jonction d'arrosage

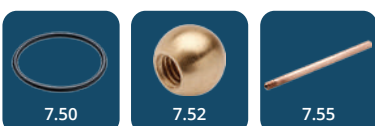



Verwendung:
Vorwiegend für Außenbearbeitung.
Zum Plan Einstechen.

Application:
Mainly for external machining.
For face machining.

Application:
Principalement pour usinage extérieur.
Pour carottage.

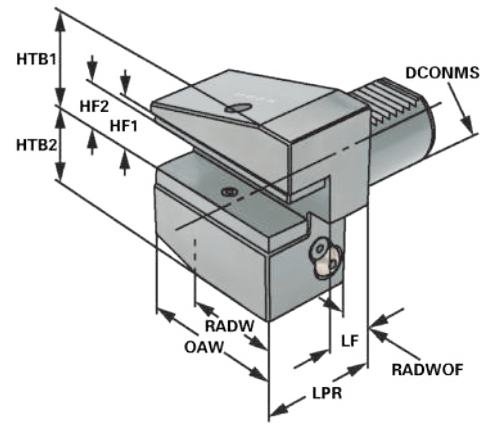

DIN ISO
10889

B3

Bestell-Nr. Order no. Référence	Abmessung Size Dimension	DCONMS	HF1	HF2	LPR	LF	OAW	RADW	RADWOF	HTB1	HTB2
169.33.12	B3 - 16 × 12 × 24	16	12	-	24	13	42	23	5	20	22
209.33.16	B3 - 20 × 16 × 30	20	16	12	30	16	55	30	7	25	30
259.33.16	B3 - 25 × 16 × 30	25	16	12	30	16	55	30	7	25	30
309.33.20	B3 - 30 × 20 × 40	30	25	20,5	40	22	70	35	10	30	43
409.33.25	B3 - 40 × 25 × 44	40	29	23	44	22	85	42,5	12,5	39,5	51
509.33.32	B3 - 50 × 32 × 55	50	34	26	55	30	100	50	16	49	61

7

Ausführung: Mit einstellbarer Kugelspritzdüse und Unterlegplatte
Version: With adjustable spray nozzle and shim
Version: Avec gicleur ajustable et semelle

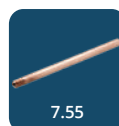
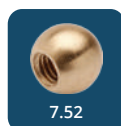



Radial toolholders form B3 overhead right, short - for tools with internal coolant
 Porte-outils radials forme B3 inversés droite, court - pour outils avec arrosage interne



Verwendung:
 Vorwiegend für Außenbearbeitung.
 Zum Plan Einstechen.

Application:
 Mainly for external machining.
 For face machining.

Application:
 Principalement pour usinage extérieur.
 Pour carottage.

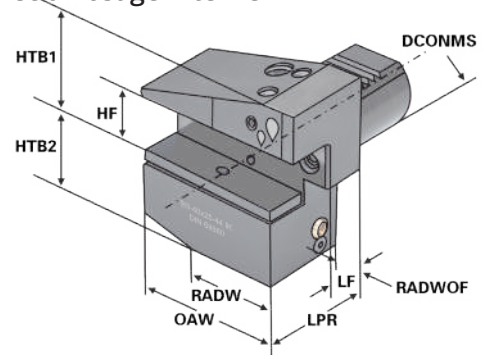

Bestell-Nr. Order no. Référence	Abmessung Size Dimension	DCONMS	HF	LPR	LF	OAW	RADW	RADWOF	HTB1	HTB2
309.33.20.IK	B3 - 30 × 20 × 40	30	20	40	22	70	35	10	35	38
409.33.25.IK	B3 - 40 × 25 × 44	40	25	44	22	85	42,5	12,5	42,5	48
509.33.32.IK	B3 - 50 × 32 × 55	50	32	55	30	100	50	16	50	60

Ausführung: Mit einstellbarer Kugelspritzdüse
Version: With adjustable spray nozzle
Version: Avec gicleur ajustable

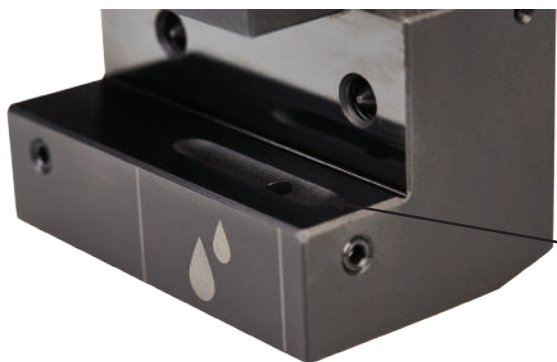

Übergabe für Kühlmittel
 Coolant supply
 Jonction d'arrosage

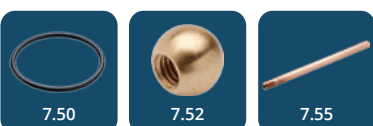



Verwendung:
Vorwiegend für Außenbearbeitung.
Zum Plan Einstechen.

Application:
Mainly for external machining.
For face machining.

Application:
Principalement pour usinage extérieur.
Pour carottage.

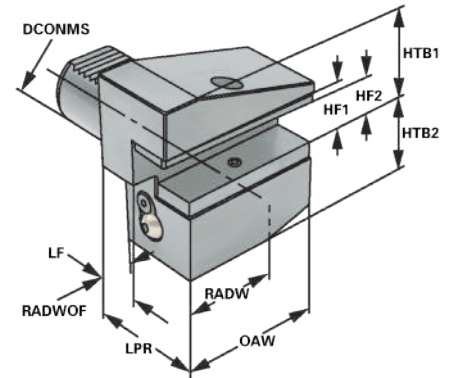

DIN ISO
10889

B4

Bestell-Nr. Order no. Référence	Abmessung Size Dimension	DCONMS	HF1	HF2	LPR	LF	OAW	RADW	RADWOF	HTB1	HTB2
169.34.12	B4 - 16 × 12 × 24	16	12	-	24	13	42	23	5	20	22
209.34.16	B4 - 20 × 16 × 30	20	16	12	30	16	55	30	7	35	30
259.34.16	B4 - 25 × 16 × 30	25	16	12	30	16	55	30	7	35	30
309.34.20	B4 - 30 × 20 × 40	30	25	20,5	40	22	70	35	10	30	42,5
409.34.25	B4 - 40 × 25 × 44	40	29	23	44	22	85	42,5	12,5	39,5	51
509.34.32	B4 - 50 × 32 × 55	50	34	26	55	30	100	50	16	49	61

7

Ausführung: Mit einstellbarer Kugelspritzdüse und Unterlegplatte
Version: With adjustable spray nozzle and shim
Version: Avec gicleur ajustable et semelle

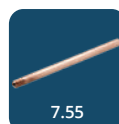
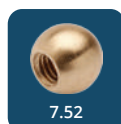



Radial toolholders form B4 overhead left, short - for tools with internal coolant

Porte-outils radials forme B4 inversés gauche, court - pour outils avec arrosage interne



Verwendung:
Vorwiegend für Außenbearbeitung.
Zum Plan Einstechen.

Application:
Mainly for external machining.
For face machining.

Application:
Principalement pour usinage extérieur.
Pour carottage.

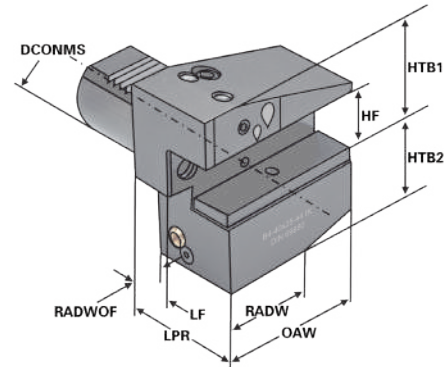

Bestell-Nr. Order no. Référence	Abmessung Size Dimension	DCONMS	HF	LPR	LF	OAW	RADW	RADWOF	HTB1	HTB2
309.34.20.IK	B4 - 30 × 20 × 40	30	20	40	22	70	35	10	35	38
409.34.25.IK	B4 - 40 × 25 × 44	40	25	44	22	85	42,5	12,5	42,5	48
509.34.32.IK	B4 - 50 × 32 × 55	50	32	55	30	100	50	16	50	60

Ausführung: Mit einstellbarer Kugelspritzdüse
Version: With adjustable spray nozzle
Version: Avec gicleur ajustable

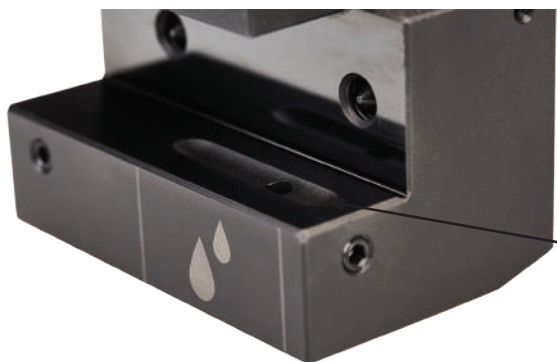

Übergabe für Kühlmittel
Coolant supply
Jonction d'arrosage

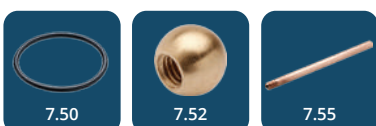

Radial toolholders form B5 right, long
 Porte-outils radials forme B5 droite, long

(DIN 69880)



Verwendung:
 Vorwiegend für Außenbearbeitung.
 Zum Plan Einstechen.

Application:
 Mainly for external machining.
 For face machining.

Application:
 Principalement pour usinage extérieur.
 Pour carottage.

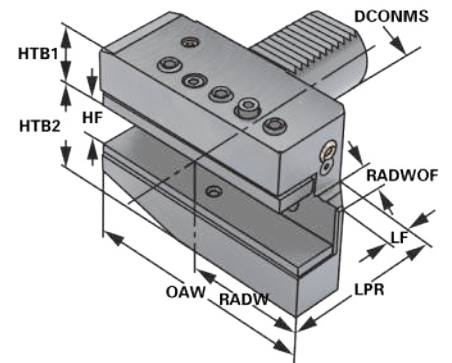

DIN ISO 10889

B5

Bestell-Nr. Order no. Référence	Abmessung Size Dimension	DCONMS	OAW	RADW	RADWOF	LF	LPR	HF	HTB1	HTB2
169.35.12	B5 - 16 × 12 × 24	16	58	39	5	13	24	12	22	20
209.35.16	B5 - 20 × 16 × 30	20	75	50	7	16	30	16	25	30
259.35.16	B5 - 25 × 16 × 30	25	75	50	7	16	30	16	25	30
309.35.20	B5 - 30 × 20 × 40	30	100	65	10	22	40	20	28	38
409.35.25	B5 - 40 × 25 × 44	40	118	75,5	12,5	22	44	25	32,5	48
509.35.32	B5 - 50 × 32 × 55	50	130	85	16	30	55	32	35	60

Ausführung: Mit einstellbarer Kugelspritzdüse und Unterlegplatte
Version: With adjustable spray nozzle and shim
Version: Avec gicleur ajustable et semelle

7

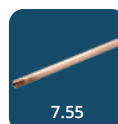
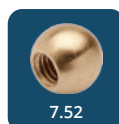



Verwendung:
Vorwiegend für Außenbearbeitung.
Zum Plan Einstechen.

Application:
Mainly for external machining.
For face machining.

Application:
Principalement pour usinage extérieur.
Pour carottage.

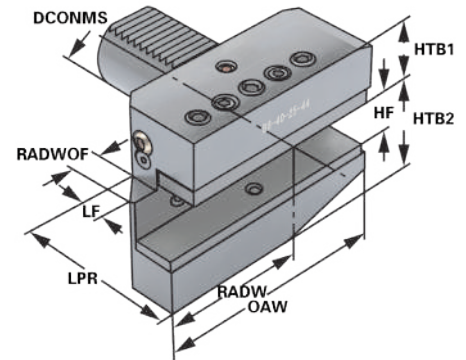

DIN ISO
10889

B6

Bestell-Nr. Order no. Référence	Abmessung Size Dimension	DCONMS	OAW	RADW	RADWOF	LF	LPR	HF	HTB1	HTB2
169.36.12	B6 - 16 × 12 × 24	16	58	39	5	13	24	12	22	20
209.36.16	B6 - 20 × 16 × 30	20	75	50	7	16	30	16	25	30
259.36.16	B6 - 25 × 16 × 30	25	75	50	7	16	30	16	25	30
309.36.20	B6 - 30 × 20 × 40	30	100	65	10	22	40	20	28	38
409.36.25	B6 - 40 × 25 × 44	40	118	75,5	12,5	22	44	25	32,5	48
509.36.32	B6 - 50 × 32 × 55	50	130	80	16	30	55	32	35	60

Ausführung: Mit einstellbarer Kugelspritzdüse und Unterlegplatte
Version: With adjustable spray nozzle and shim
Version: Avec gicleur ajustable et semelle

7

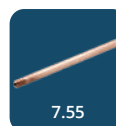
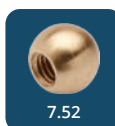
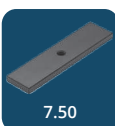



Verwendung:
Vorwiegend für Außenbearbeitung.
Zum Plan Einstechen.

Application:
Mainly for external machining.
For face machining.

Application:
Principalement pour usinage extérieur.
Pour carottage.

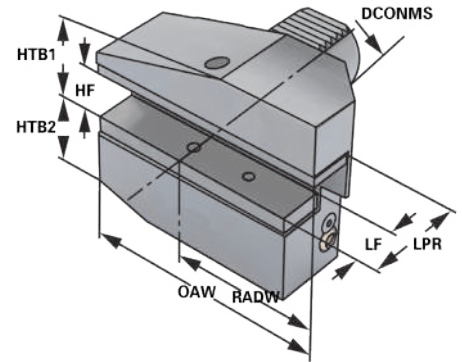

DIN ISO 10889

B7

Bestell-Nr. Order no. Référence	Abmessung Size Dimension	DCONMS	OAW	RADW	RADWOF	LF	LPR	HF	HTB1	HTB2
169.37.12	B7 - 16 × 12 × 24	16	58	39	5	13	24	12	20	22
209.37.16	B7 - 20 × 16 × 30	20	75	50	7	16	30	16	30	25
259.37.16	B7 - 25 × 16 × 30	25	75	50	7	16	30	16	30	25
309.37.20	B7 - 30 × 20 × 40	30	100	65	10	22	40	20	42	30
409.37.25	B7 - 40 × 25 × 44	40	118	75,5	12,5	22	44	25	48	42,5
509.37.32	B7 - 50 × 32 × 55	50	130	80	16	30	55	32	60	50

Ausführung: Mit einstellbarer Kugelspritzdüse und Unterlegplatte
Version: With adjustable spray nozzle and shim
Version: Avec gicleur ajustable et semelle

7



7.50



7.50

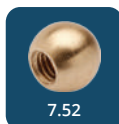

7.52

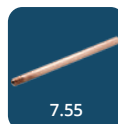

7.55



Verwendung:
 Vorwiegend für Außenbearbeitung.
 Zum Plan Einstechen.

Application:
 Mainly for external machining.
 For face machining.

Application:
 Principalement pour usinage extérieur.
 Pour carottage.

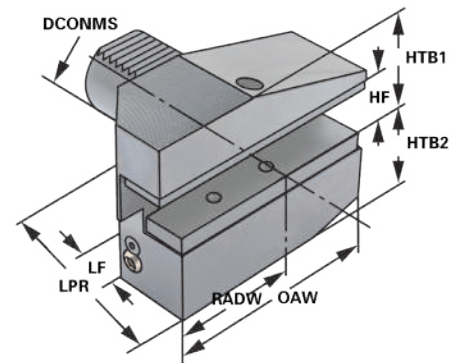

DIN ISO 10889

B8

Bestell-Nr. Order no. Référence	Abmessung Size Dimension	DCONMS	OAW	RADW	RADWOF	LF	LPR	HF	HTB1	HTB2
169.38.12	B8 - 16 × 12 × 24	16	58	39	5	13	24	12	20	22
209.38.16	B8 - 20 × 16 × 30	20	75	50	7	16	30	16	30	25
259.38.16	B8 - 25 × 16 × 30	25	75	50	7	16	30	16	30	25
309.38.20	B8 - 30 × 20 × 40	30	100	65	10	22	40	20	38	35
409.38.25	B8 - 40 × 25 × 44	40	118	75,5	12,5	22	44	25	48	42,5
509.38.32	B8 - 50 × 32 × 55	50	130	80	16	30	55	32	60	50

Ausführung: Mit einstellbarer Kugelspritzdüse und Unterlegplatte
Version: With adjustable spray nozzle and shim
Version: Avec gicleur ajustable et semelle

7

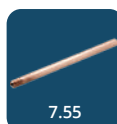
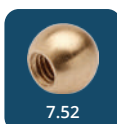
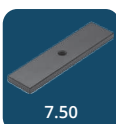



Verwendung:
Vorwiegend für Außenbearbeitung.
Zum Plan Einstechen.

Application:
Mainly for external machining.
For face machining.

Application:
Principalement pour usinage extérieur.
Pour carottage.

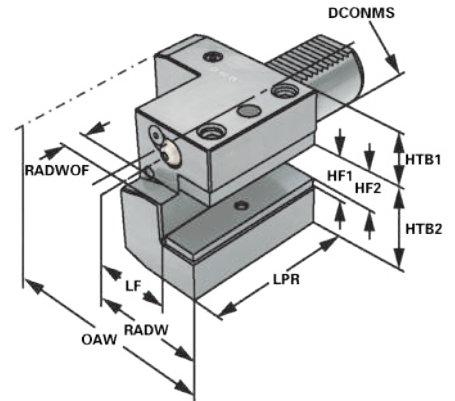

Bestell-Nr. Order no. Référence	Abmessung Size Dimension	DCONMS	HF1	HF2	OAW	RADH	LF	LPR	RADWOF	HTB1	HTB2
169.41.12	C1 - 16 × 12	16	12	10	43	24	13	44	5	20	22
209.41.16	C1 - 20 × 16	20	16	12	52	27	13	50	7	25	30
259.41.16	C1 - 25 × 16	25	16	12	58	33	19	55	7	25	30
309.41.20	C1 - 30 × 20	30	20	16	70	35	17	70	10	28	38
409.41.25	C1 - 40 × 25	40	25	20	85	42,5	21	85	12,5	32,5	48
509.41.32	C1 - 50 × 32	50	32	25	100	50	26	100	16	35	60

7

Ausführung: Mit einstellbarer Kugelspritzdüse und Unterlegplatte
Version: With adjustable spray nozzle and shim
Version: Avec gicleur ajustable et semelle





Axial toolholders form C1 right - for tools with internal coolant
 Porte-outils axials forme C1 droite - pour outils avec arrosage interne



Verwendung:
 Vorwiegend für Außenbearbeitung.
 Zum Plan Einstechen.

Application:
 Mainly for external machining.
 For face machining.

Application:
 Principalement pour usinage extérieur.
 Pour carottage.

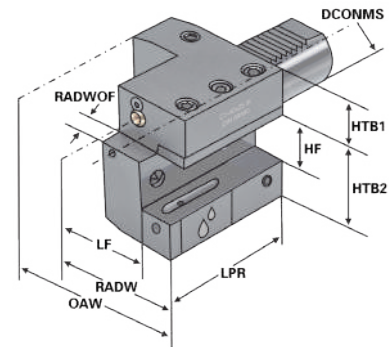

Bestell-Nr. Order no. Référence	Abmessung Size Dimension	DCONMS	HF	OAW	RADH	LF	LPR	RADWOF	HTB1	HTB2
309.41.20.IK	C1 - 30 × 20	30	20	76	49	31	70	10	24	42
409.41.25.IK	C1 - 40 × 25	40	25	90	55	33	85	12,5	32,5	48
509.41.32.IK	C1 - 50 × 32	50	32	105	62	38	100	16	35	60

Ausführung: Mit einstellbarer Kugelspritzdüse
Version: With adjustable spray nozzle
Version: Avec gicleur ajustable

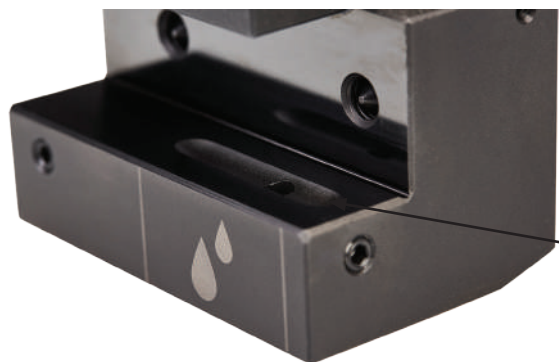

Übergabe für Kühlmittel
 Coolant supply
 Jonction d'arrosage

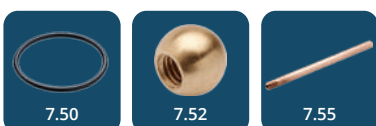



Verwendung:
Vorwiegend für Außenbearbeitung.
Zum Plan Einstechen.

Application:
Mainly for external machining.
For face machining.

Application:
Principalement pour usinage extérieur.
Pour carottage.

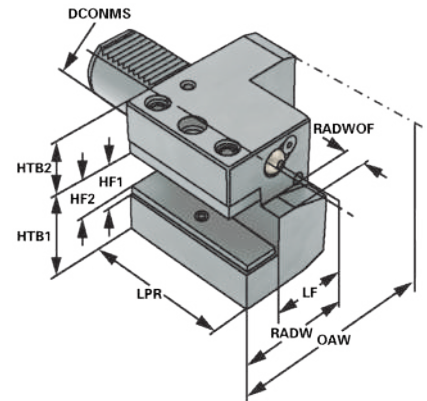

Bestell-Nr. Order no. Référence	Abmessung Size Dimension	DCONMS	HF1	HF2	OAW	RADH	LF	LPR	RADWOF	HTB1	HTB2
169.42.12	C2 - 16 × 12	16	12	-	43	24	13	44	5	20	22
209.42.16	C2 - 20 × 16	20	16	12	65	40	26	50	7	25	30
259.42.16	C2 - 25 × 16	25	16	12	58	33	26	55	7	20	30
309.42.20	C2 - 30 × 20	30	20	16	76	41	23	70	10	28	38
409.42.25	C2 - 40 × 25	40	25	20	90	47,5	25,5	85	12,5	32,5	48
509.42.32	C2 - 50 × 32	50	32	25	105	55	30,5	100	16	35	60

Ausführung: Mit einstellbarer Kugelspritzdüse und Unterlegplatte
Version: With adjustable spray nozzle and shim
Version: Avec gicleur ajustable et semelle

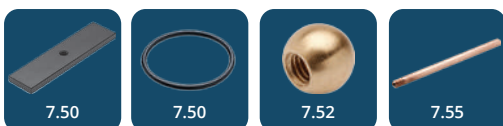

Axial toolholders form C2 left - for tools with internal coolant
 Porte-outils axials forme C2 gauche - pour outils avec arrosage interne



Verwendung:
 Vorwiegend für Außenbearbeitung.
 Zum Plan Einstechen.

Application:
 Mainly for external machining.
 For face machining.

Application:
 Principalement pour usinage extérieur.
 Pour carottage.

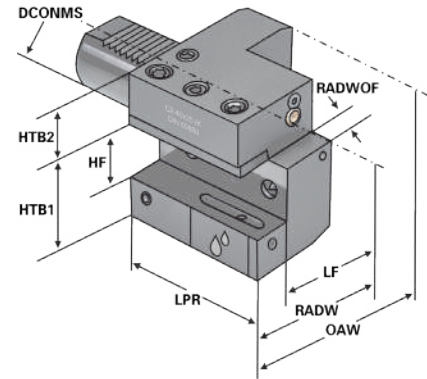

Bestell-Nr. Order no. Référence	Abmessung Size Dimension	DCONMS	HF	OAW	RADH	LF	LPR	RADWOF	HTB1	HTB2
309.42.20.IK	C2 - 30 × 20	30	20	76	49	31	70	10	24	42
409.42.25.IK	C2 - 40 × 25	40	25	90	55	33	85	12,5	32,5	48
509.42.32.IK	C2 - 50 × 32	50	32	105	62	38	100	16	35	60

Ausführung: Mit einstellbarer Kugelspritzdüse
Version: With adjustable spray nozzle
Version: Avec gicleur ajustable



Übergabe für Kühlmittel
 Coolant supply
 Jonction d'arrosage

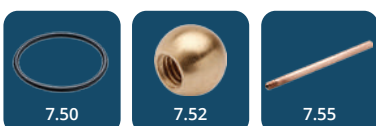



Verwendung:
 Vorwiegend für Außenbearbeitung.
 Zum Plan Einstechen.

Application:
 Mainly for external machining.
 For face machining.

Application:
 Principalement pour usinage extérieur.
 Pour carottage.

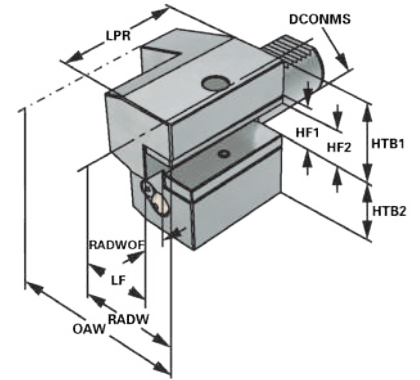

DIN ISO
10889

C3

Bestell-Nr. Order no. Référence	Abmessung Size Dimension	DCONMS	HF1	HF2	OAW	RADH	LF	LPR	RADWOF	HTB1	HTB2
169.43.12	C3 - 16 × 12	16	12	10	43	24	13	44	5	20	22
209.43.16	C3 - 20 × 16	20	16	12	52	27	13	55	7	30	25
259.43.16	C3 - 25 × 16	25	16	12	58	33	19	55	7	30	25
309.43.20	C3 - 30 × 20	30	20	16	70	35	17	70	10	38	35
409.43.25	C3 - 40 × 25	40	25	20	85	42,5	21	85	12,5	48	42,5
509.43.32	C3 - 50 × 32	50	32	25	100	50	26	100	16	60	50

7

Ausführung: Mit einstellbarer Kugelspritzdüse und Unterlegplatte
Version: With adjustable spray nozzle and shim
Version: Avec gicleur ajustable et semelle

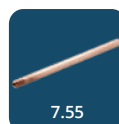
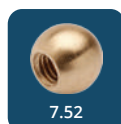

Axial toolholders form C3 overhead right - for tools with internal coolant

Porte-outils axials forme C3 inversés droite - pour outils avec arrosage interne



Verwendung:
Vorwiegend für Außenbearbeitung.
Zum Plan Einstechen.

Application:
Mainly for external machining.
For face machining.

Application:
Principalement pour usinage extérieur.
Pour carottage.

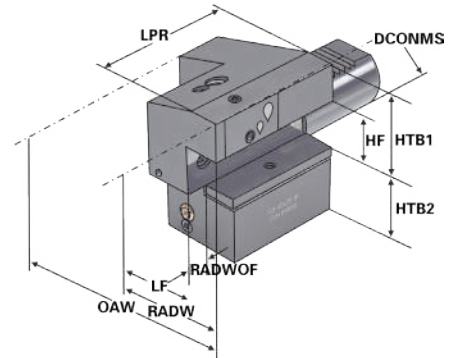

DIN ISO
10889

C3



Bestell-Nr. Order no. Référence	Abmessung Size Dimension	DCONMS	HF	OAW	RADH	LF	LPR	RADWOF	HTB1	HTB2
309.43.20.IK	C3 - 30 × 20	30	20	70	35	17	70	10	38	35
409.43.25.IK	C3 - 40 × 25	40	25	85	42,5	21	85	12,5	48	42,5
509.43.32.IK	C3 - 50 × 32	50	32	100	50	26	100	16	60	50

Ausführung: Mit einstellbarer Kugelspritzdüse
Version: With adjustable spray nozzle
Version: Avec gicleur ajustable

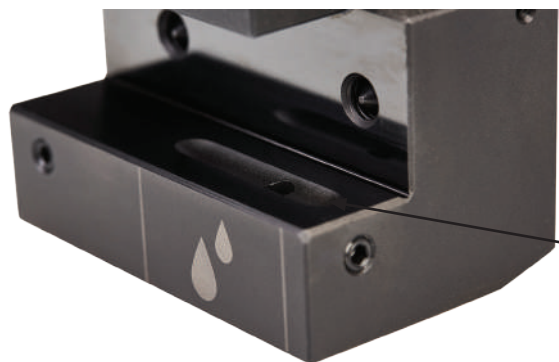

Übergabe für Kühlmittel
Coolant supply
Jonction d'arrosage

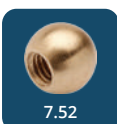



Verwendung:
Vorwiegend für Außenbearbeitung.
Zum Plan Einstechen.

Application:
Mainly for external machining.
For face machining.

Application:
Principalement pour usinage extérieur.
Pour carottage.

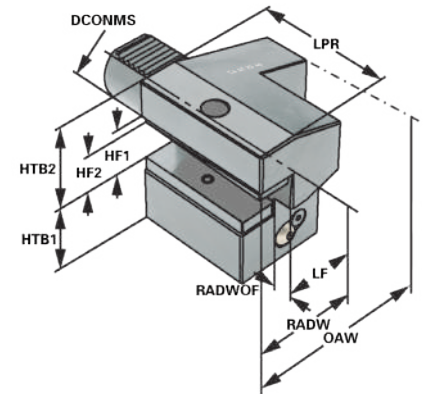

Bestell-Nr. Order no. Référence	Abmessung Size Dimension	DCONMS	HF1	HF2	OAW	RADH	LF	LPR	RADWOF	HTB1	HTB2
169.44.12	C4 - 16 × 12	16	12	10	43	24	13	44	5	22	20
209.44.16	C4 - 20 × 16	20	16	12	65	40	26	50	7	30	25
259.44.16	C4 - 25 × 16	25	16	12	58	33	19	55	7	30	25
309.44.20	C4 - 30 × 20	30	20	16	76	41	23	70	10	38	35
409.44.25	C4 - 40 × 25	40	25	20	90	47,5	25,5	85	12,5	48	42,5
509.44.32	C4 - 50 × 32	50	32	25	105	55	30,5	100	16	60	50

Ausführung: Mit einstellbarer Kugelspritzdüse und Unterlegplatte
Version: With adjustable spray nozzle and shim
Version: Avec gicleur ajustable et semelle





Axial toolholders form C4 overhead left - for tools with internal coolant

Porte-outils axials forme C4 inversés gauche - pour outils avec arrosage interne



Verwendung:
Vorwiegend für Außenbearbeitung.
Zum Plan Einstechen.

Application:
Mainly for external machining.
For face machining.

Application:
Principalement pour usinage extérieur.
Pour carottage.

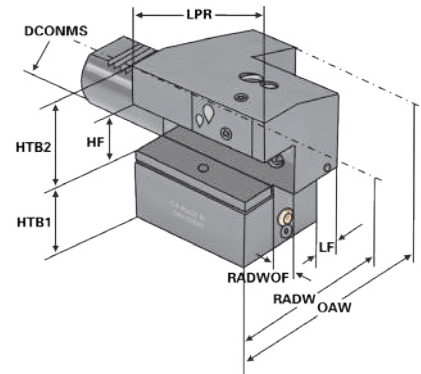

Bestell-Nr. Order no. Référence	Abmessung Size Dimension	DCONMS	HF	OAW	RADH	LF	LPR	RADWOF	HTB1	HTB2
309.44.20.IK	C4 - 30 × 20	30	20	70	35	17	70	10	38	35
409.44.25.IK	C4 - 40 × 25	40	25	85	42,5	21	85	12,5	48	42,5
509.44.32.IK	C4 - 50 × 32	50	32	100	50	26	100	16	60	50

Ausführung: Mit einstellbarer Kugelspritzdüse
Version: With adjustable spray nozzle
Version: Avec gicleur ajustable

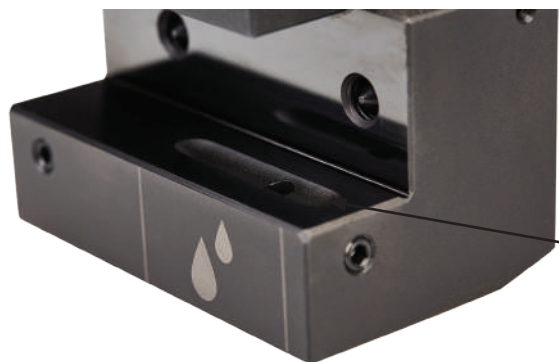

Übergabe für Kühlmittel
Coolant supply
Jonction d'arrosage

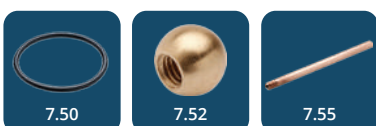



Verwendung:
Vorwiegend für Außenbearbeitung.
Zum Plan Einstechen.

Application:
Mainly for external machining.
For face machining.

Application:
Principalement pour usinage extérieur.
Pour carottage.

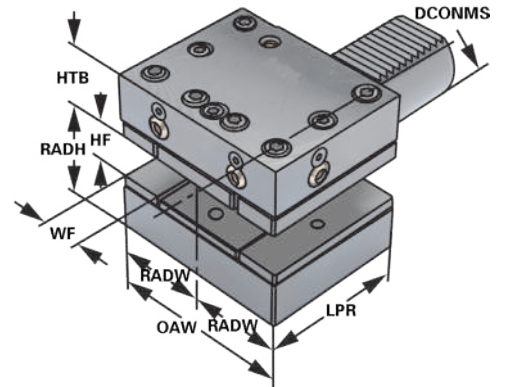

DIN ISO
10889

D1

Bestell-Nr. Order no. Référence	Abmessung Size Dimension	DCONMS	OAW	RADW	WF	LPR	HF	HTB	RADH
309.89.12	D1 - 30 x 20 x 60	30	76	41	18	60	20	28	38
409.89.16	D1 - 40 x 25 x 72	40	90	47,5	22	72	25	32,5	48
509.89.20	D1 - 50 x 32 x 85	50	105	55	24,5	85	32	35	60

Ausführung: Mit einstellbarer Kugelspritzdüse und Unterlegplatte
Version: With adjustable spray nozzle and shim
Version: Avec gicleur ajustable et semelle

7



7.50



7.50

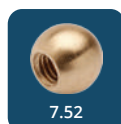

7.52

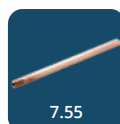

7.55



Verwendung:
 Vorwiegend für Außenbearbeitung.
 Zum Plan Einstechen.

Application:
 Mainly for external machining.
 For face machining.

Application:
 Principalement pour usinage extérieur.
 Pour carottage.

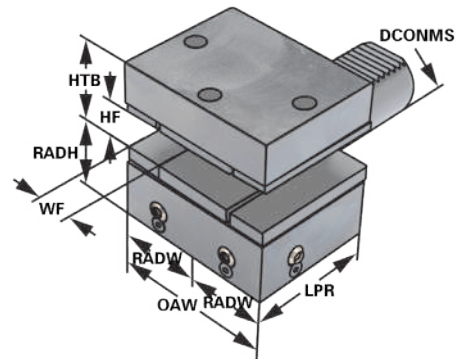

DIN ISO
10889

D2

Bestell-Nr. Order no. Référence	Abmessung Size Dimension	DCONMS	OAW	RADW	WF	LPR	HF	HTB	RADH
309.90.12	D2 - 30 × 20 × 60	30	76	41	18	60	20	35	38
409.90.16	D2 - 40 × 25 × 72	40	90	47,5	22	72	25	42,5	48
509.90.20	D2 - 50 × 32 × 85	50	105	55	24,5	85	32	50	60

Ausführung: Mit einstellbarer Kugelspritzdüse und Unterlegplatte
Version: With adjustable spray nozzle and shim
Version: Avec gicleur ajustable et semelle





Verwendung:
Vorwiegend für Außenbearbeitung.
Zum Plan Einstechen.

Application:
Mainly for external machining.
For face machining.

Application:
Principalement pour usinage extérieur.
Pour carottage.

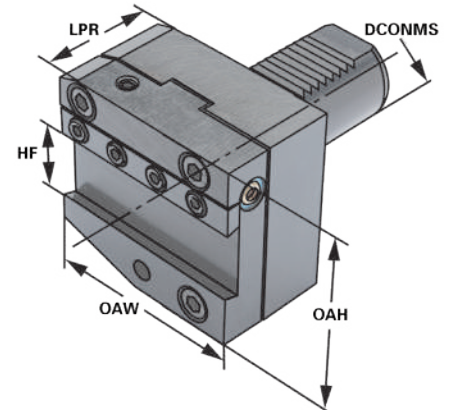

DIN ISO 10889

AR

Bestell-Nr. Order no. Référence	Abmessung Size Dimension	DCONMS	OAW	OAH	LPR	HF
309.65.26	AR - 30 × 26	30	70	70	50	26
409.65.32	AR - 40 × 32	40	85	80	50	32
509.65.32	AR - 50 × 32	50	100	80	50	32

Ausführung: Mit einstellbarer Kugelspritzdüse
Version: With adjustable spray nozzle
Version: Avec gicleur ajustable

7



7.50

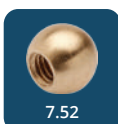

7.52

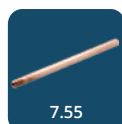

7.55



Parting-off toolholders left height adjustable
 Porte-lames de tronçonnage gauche réglage en hauteur

(DIN 69880)



Verwendung:
 Vorwiegend für Außenbearbeitung.
 Zum Plan Einstechen.

Application:
 Mainly for external machining.
 For face machining.

Application:
 Principalement pour usinage extérieur.
 Pour carottage.

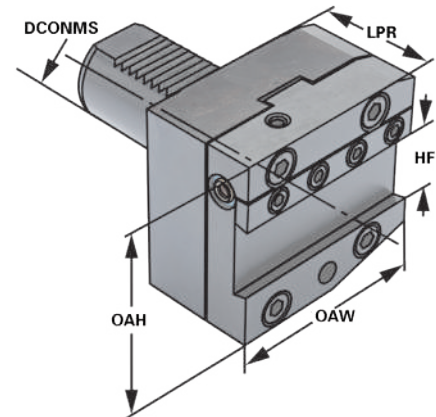

DIN ISO
10889

AL

Bestell-Nr. Order no. Référence	Abmessung Size Dimension	DCONMS	OAW	OAH	LPR	HF
309.66.26	AL - 30 × 26	30	70	70	50	26
409.66.32	AL - 40 × 32	40	85	80	50	32
509.66.32	AL - 50 × 32	50	100	80	50	32

Ausführung: Mit einstellbarer Kugelspritzdüse
Version: With adjustable spray nozzle
Version: Avec gicleur ajustable

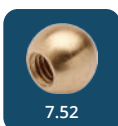



Collet chucks form E3 DIN 6391 for collets ISO 10897 (DIN 6388) OZ-system
Mandrins à pinces forme E3 DIN 6391 pour pinces ISO 10897 (DIN 6388) système OZ

**Verwendung:**

Zur Aufnahme von Werkzeugen mit
Zylinderschaft in Spannzangen.

Application:

For mounting straight-shank tools in
collets.

Application:

Pour le serrage d'outils avec queue
cylindrique dans des pinces de serrage.

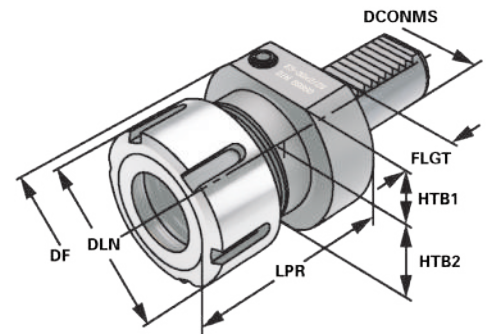
DIN ISO
10889

E3

ISO
10897

13.04

Bestell-Nr. Order no. Référence	Abmessung Size Dimension	DCONMS	DCONWS Spannbereich Capacity Cap.	Typ	DF	DLN	HTB1	HTB2	LPR	FLGT
169.01.16	E3 - 16 × 2 - 16	16	2 - 16	415E OZ 16	40	43	18	18	45,5	13
209.01.16	E3 - 20 × 2 - 16	20	2 - 16	415E OZ 16	50	43	25	23	57	18
259.01.16	E3 - 25 × 2 - 16	25	2 - 16	415E OZ 16	58	43	25	25	57	18
309.01.16	E3 - 30 × 2 - 16	30	2 - 16	415E OZ 16	68	43	28	30	57	22
309.01.25	E3 - 30 × 2 - 25	30	2 - 25	462E OZ 25	68	60	28	30	75	22
409.01.25	E3 - 40 × 2 - 25	40	2 - 25	462E OZ 25	83	60	32,5	41,5	75	22
409.01.32	E3 - 40 × 3 - 32	40	3 - 32	467E OZ 32	83	72	32,5	41,5	90	22
509.01.25	E3 - 50 × 2 - 25	50	2 - 25	462E OZ 25	98	60	35	49	75	30
509.01.32	E3 - 50 × 3 - 32	50	3 - 32	467E OZ 32	98	72	35	49	90	30

Lieferumfang: Mit kugellagerter Spannmutter
Delivery: With ball bearing clamping nut
Livraison: Avec écrou de serrage à roulement à billes

7

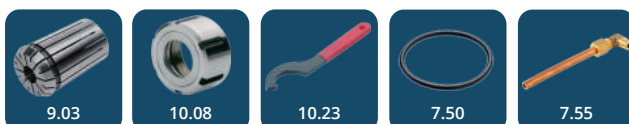

Collet chucks form E4 for collets ISO 15488 (DIN 6499) ER-system
Mandrins à pinces forme E4 pour pinces ISO 15488 (DIN 6499) système ER

**Verwendung:**

Zur Aufnahme von Werkzeugen mit Zylinderschaft in Spannzangen.

Application:

For mounting straight-shank tools in collets.

Application:

Pour le serrage d'outils avec queue cylindrique dans des pinces de serrage.

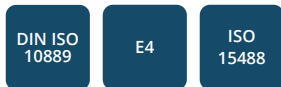
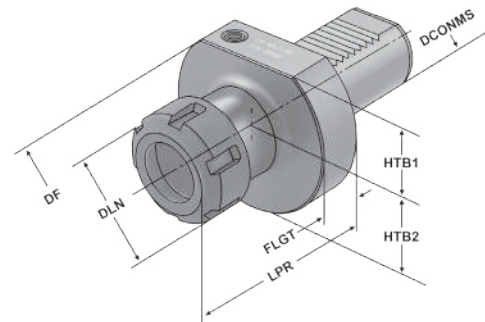

Bestell-Nr. Order no. Référence	Abmessung Size Dimension	DCONMS	DCONWS Spannbereich Capacity Cap.	Typ	DF	DLN	HTB1	HTB2	LPR	FLGT
169.02.10	E4 - 16 × 1 - 10	16	1 - 10	426E ER 16	40	28	18	18	40	13
209.02.10	E4 - 20 × 1 - 10	20	1 - 10	426E ER 16	50	28	25	23	42	18
209.02.16	E4 - 20 × 2 - 16	20	2 - 16	430E ER 25	50	42	25	23	46	18
259.02.16	E4 - 25 × 2 - 16	25	2 - 16	430E ER 25	58	42	25	25	55	18
259.02.20	E4 - 25 × 2 - 20	25	2 - 20	470E ER 32	58	50	25	25	55	18
309.02.16	E4 - 30 × 2 - 16	30	2 - 16	430E ER 25	68	42	28	30	57	22
309.02.20	E4 - 30 × 2 - 20	30	2 - 20	470E ER 32	68	50	28	30	75	22
309.02.26	E4 - 30 × 3 - 26	30	3 - 26	472E ER 40	68	63	28	30	75	22
409.02.16	E4 - 40 × 2 - 16	40	2 - 16	430E ER 25	83	42	32,5	41,5	75	22
409.02.20	E4 - 40 × 2 - 20	40	2 - 20	470E ER 32	83	50	32,5	41,5	75	22
409.02.26	E4 - 40 × 3 - 26	40	3 - 26	472E ER 40	83	63	32,5	41,5	75	22
509.02.26	E4 - 50 × 3 - 26	50	3 - 26	472E ER 40	98	63	35	49	75	30

Lieferumfang: Mit gewuchteter Spannmutter
Delivery: With balanced clamping nut
Livraison: Avec écrou de serrage équilibré

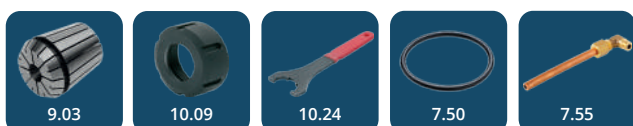



Verwendung:

Zur Aufnahme von allen nach DIN 6595 genormten Vollbohrern mit Zylinder-schaft.

Application:

For all solid drills with cylindrical shank according to DIN 6595.

Application:

Pour le serrage de forets à queue cylindrique suivant DIN 6595.

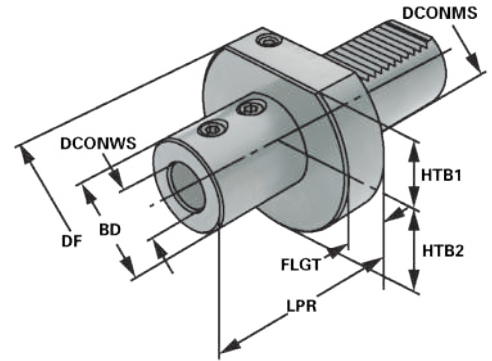

DIN ISO 10889

E1

Bestell-Nr. Order no. Référence	Abmessung Size Dimension	DCONMS	DCONWS	BD	DF	HTB1	HTB2	LPR	FLGT
209.51.16	E1 - 20 × 16	20	16	40	50	22	22	67	18
209.51.20	E1 - 20 × 20	20	20	40	50	22	22	67	18
209.51.25	E1 - 20 × 25	20	25	45	50	22	22	71	18
259.51.16	E1 - 25 × 16	25	16	40	58	25	25	67	18
259.51.20	E1 - 25 × 20	25	20	40	58	25	25	67	18
259.51.25	E1 - 25 × 25	25	25	45	58	25	25	71	18
259.51.32	E1 - 25 × 32	25	32	58	58	25	25	78	-
309.51.16	E1 - 30 × 16	30	16	36	68	28	30	64	22
309.51.20	E1 - 30 × 20	30	20	40	68	28	30	67	22
309.51.25	E1 - 30 × 25	30	25	45	68	28	30	71	22
309.51.32	E1 - 30 × 32	30	32	52	68	28	30	75	22
309.51.40	E1 - 30 × 40	30	40	60	68	28	30	95	22
409.51.16	E1 - 40 × 16	40	16	36	83	32,5	41,5	64	22
409.51.20	E1 - 40 × 20	40	20	40	83	32,5	41,5	67	22
409.51.25	E1 - 40 × 25	40	25	45	83	32,5	41,5	75	22
409.51.32	E1 - 40 × 32	40	32	52	83	32,5	41,5	75	22
409.51.40	E1 - 40 × 40	40	40	65	83	32,5	41,5	90	22
509.51.16	E1 - 50 × 16	50	16	40	98	35	49	66	30
509.51.20	E1 - 50 × 20	50	20	40	98	35	49	66	30
509.51.25	E1 - 50 × 25	50	25	45	98	35	49	80	30
509.51.32	E1 - 50 × 32	50	32	52	98	35	49	80	30
509.51.40	E1 - 50 × 40	50	40	65	98	35	49	90	30
509.51.50	E1 - 50 × 50	50	50	75	98	35	49	100	30

Lieferumfang: Mit Spannschrauben
Delivery: With clamping screws
Livraison: Avec vis de serrage

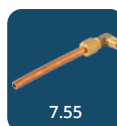



Drill chuck adaptors DIN 238

(DIN 69880)

Arbres pour mandrins de perçage DIN 238



Verwendung:
Zur Aufnahme von Bohrfuttern.
Application:
For mounting drill chucks.
Application:
Pour le serrage de mandrins de perçage.

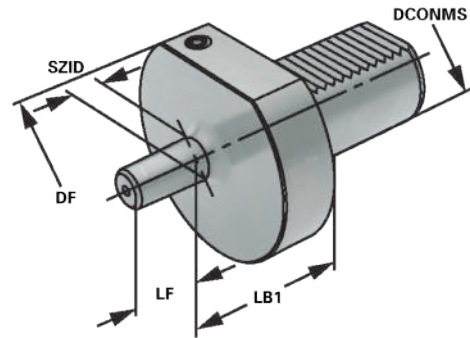

DIN ISO
10889

DIN
238

Bestell-Nr. Order no. Référence	Abmessung Size Dimension	DCONMS	SZID	DF	LB1	LF
309.14.16	30 - B16	30	B16	68	27	24
409.14.16	40 - B16	40	B16	83	27	24
509.14.16	50 - B16	50	B16	98	35	24

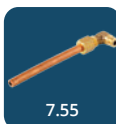



Verwendung:
Für Innenbearbeitung mit Bohrstangen.
Application:
For internal machining with boring bars.
Application:
Pour l'usinage intérieur avec barres d'alésage.

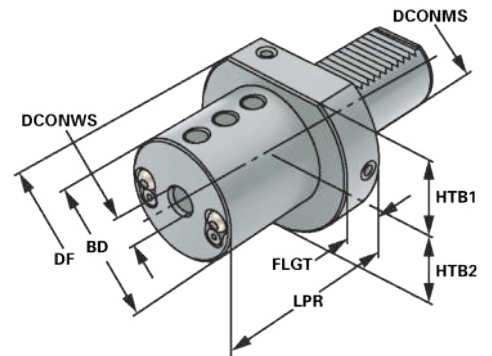

DIN ISO 10889

E2

Bestell-Nr. Order no. Référence	Abmessung Size Dimension	DCONMS	DCONWS	DF	BD	HTB1	HTB2	LPR	FLGT
169.52.06	E2 - 16 × 06	16	6	40	32	18	20	44	13
169.52.08	E2 - 16 × 08	16	8	40	32	18	20	44	13
169.52.10	E2 - 16 × 10	16	10	40	32	18	20	44	13
169.52.12	E2 - 16 × 12	16	12	40	32	18	20	44	13
169.52.16	E2 - 16 × 16	16	16	40	32	18	20	44	13
209.52.08	E2 - 20 × 08	20	8	50	40	23	25	50	18
209.52.10	E2 - 20 × 10	20	10	50	40	23	25	50	18
209.52.12	E2 - 20 × 12	20	12	50	40	23	25	50	18
209.52.16	E2 - 20 × 16	20	16	50	40	23	25	50	18
209.52.20	E2 - 20 × 20	20	20	50	40	23	25	50	18
259.52.08	E2 - 25 × 08	25	8	58	40	25	25	50	18
259.52.10	E2 - 25 × 10	25	10	58	40	25	25	50	18
259.52.12	E2 - 25 × 12	25	12	58	40	25	25	50	18
259.52.16	E2 - 25 × 16	25	16	58	40	25	25	50	18
259.52.20	E2 - 25 × 20	25	20	58	58	25	25	50	-
259.52.25	E2 - 25 × 25	25	25	58	58	25	25	60	-

Ausführung: Mit einstellbaren Kugelspritzdüsen
Version: With adjustable spray nozzles
Version: Avec gicleurs ajustables

Lieferumfang: Mit Spannschrauben
Delivery: With clamping screws
Livraison: Avec vis de serrage

7

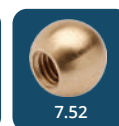
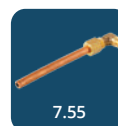
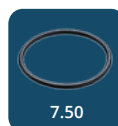



Verwendung:
Für Innenbearbeitung mit Bohrstäben.

Application:
For internal machining with boring bars.

Application:
Pour l'usinage intérieur avec barres d'alésage.

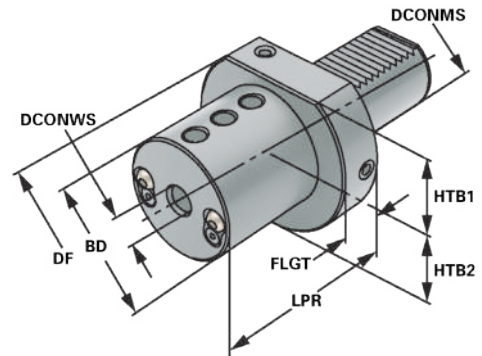
DIN ISO
10889

E2

Bestell-Nr. Order no. Référence	Abmessung Size Dimension	DCONMS	DCONWS	DF	BD	HTB1	HTB2	LPR	FLGT
309.52.08	E2 - 30 × 08	30	8	68	55	28	30	60	22
309.52.10	E2 - 30 × 10	30	10	68	55	28	30	60	22
309.52.12	E2 - 30 × 12	30	12	68	55	28	30	60	22
309.52.16	E2 - 30 × 16	30	16	68	55	28	30	60	22
309.52.20	E2 - 30 × 20	30	20	68	55	28	30	60	22
309.52.25	E2 - 30 × 25	30	25	68	55	28	30	60	22
309.52.32	E2 - 30 × 32	30	32	68	68	28	30	75	-
409.52.08	E2 - 40 × 08	40	8	83	55	32,5	41,5	75	22
409.52.10	E2 - 40 × 10	40	10	83	55	32,5	41,5	75	22
409.52.12	E2 - 40 × 12	40	12	83	55	32,5	41,5	75	22
409.52.16	E2 - 40 × 16	40	16	83	55	32,5	41,5	75	22
409.52.20	E2 - 40 × 20	40	20	83	55	32,5	41,5	75	22
409.52.25	E2 - 40 × 25	40	25	83	55	32,5	41,5	75	22
409.52.32	E2 - 40 × 32	40	32	83	83	32,5	41,5	75	-
409.52.40	E2 - 40 × 40	40	40	83	83	32,5	41,5	90	-
509.52.12	E2 - 50 × 12	50	12	98	68	35	49	90	30
509.52.16	E2 - 50 × 16	50	16	98	68	35	49	90	30
509.52.20	E2 - 50 × 20	50	20	98	68	35	49	90	30
509.52.25	E2 - 50 × 25	50	25	98	68	35	49	90	30
509.52.32	E2 - 50 × 32	50	32	98	68	35	49	90	30
509.52.40	E2 - 50 × 40	50	40	98	98	35	49	90	-
509.52.50	E2 - 50 × 50	50	50	98	98	35	49	100	-

Ausführung: Mit einstellbaren Kugelspritzdüsen
Version: With adjustable spray nozzles
Version: Avec gicleurs ajustables

Lieferumfang: Mit Spannschrauben
Delivery: With clamping screws
Livraison: Avec vis de serrage



7.37



7.38



10.67



7.50



7.55



7.52



10.104



Verwendung:
Für Innenbearbeitung mit Bohrstangen.

Application:
For internal machining with boring bars.

Application:
Pour l'usinage intérieur avec barres d'alésage.

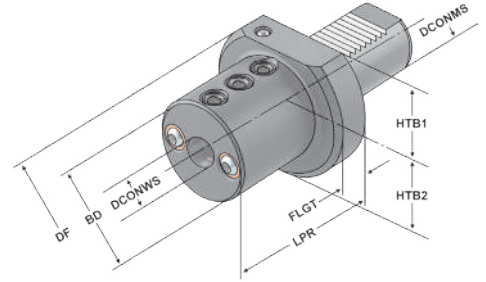

DIN ISO 10889

E2

Bestell-Nr. Order no. Référence	Abmessung Size Dimension	DCONMS	DCONWS	DF	BD	HTB1	HTB2	LPR	FLGT
309.53.10	E2 - 30 × 10	30	10	68	50	28	30	60	22
309.53.12	E2 - 30 × 12	30	12	68	50	28	30	60	22
309.53.16	E2 - 30 × 16	30	16	68	55	28	30	60	22
309.53.20	E2 - 30 × 20	30	20	68	55	28	30	60	22
309.53.25	E2 - 30 × 25	30	25	68	55	28	30	60	22
309.53.32	E2 - 30 × 32	30	32	68	68	28	30	65	-
409.53.08	E2 - 40 × 08	40	8	83	50	32,5	41,5	75	22
409.53.10	E2 - 40 × 10	40	10	83	50	32,5	41,5	75	22
409.53.12	E2 - 40 × 12	40	12	83	50	32,5	41,5	75	22
409.53.16	E2 - 40 × 16	40	16	83	55	32,5	41,5	75	22
409.53.20	E2 - 40 × 20	40	20	83	55	32,5	41,5	75	22
409.53.25	E2 - 40 × 25	40	25	83	60	32,5	41,5	75	22
409.53.32	E2 - 40 × 32	40	32	83	72	32,5	41,5	75	-
409.53.40	E2 - 40 × 40	40	40	83	83	32,5	41,5	85	-

7

Ausführung: Mit einstellbaren Kugelspritzdüsen
Version: With adjustable spray nozzles
Version: Avec gicleurs ajustables

Lieferumfang: Mit Spannschrauben
Delivery: With clamping screws
Livraison: Avec vis de serrage



Spannmöglichkeit beidseitig
Clamping possible on both sides
Possibilité de serrage des deux côtés



7.37



7.38



10.67



7.50



7.55

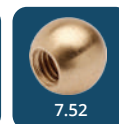

7.52



10.104

Boring bar holders form E2 slotted

(DIN 69880)

Porte-outils pour barres d'alésage forme E2 pour barre d'alésage fendu



Verwendung:
Für Innenbearbeitung mit Bohrstangen.

Application:
For internal machining with boring bars.

Application:
Pour l'usinage intérieur avec barres d'alésage.

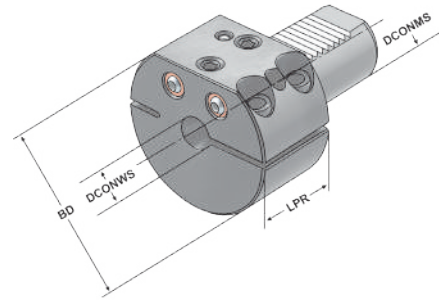
DIN ISO
10889

E2

Bestell-Nr. Order no. Référence	Abmessung Size Dimension	DCONMS	DCONWS	BD	LPR
309.55.16	E2 - 30 × 16	30	16	68	42
309.55.20	E2 - 30 × 20	30	20	68	42
409.55.16	E2 - 40 × 16	40	16	83	46
409.55.20	E2 - 40 × 20	40	20	83	46
409.55.25	E2 - 40 × 25	40	25	83	46
409.55.32	E2 - 40 × 32	40	32	83	90

Ausführung: Mit einstellbaren Kugelspritzdüsen
Version: *With adjustable spray nozzles*
Version: Avec gicleurs ajustables

Lieferumfang: Mit Spannschrauben
Delivery: *With clamping screws*
Livraison: Avec vis de serrage

7





Form 1



Form 2

Verwendung:

Reduzierung zum Spannen von Werkzeugen mit Zylinderschaft, wie z. B. Feindreh-Bohrstangen.

Application:

Reduction for mounting tools with straight-shank, such as precision boring bars.

Application:

Réduction pour le serrage d'outils avec queue cylindrique, p. ex. barres d'alésage pour tournage de finition.

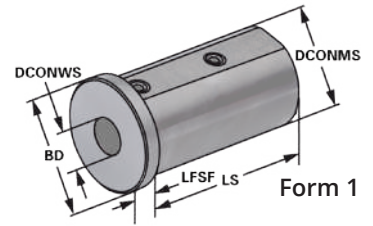

Form 1

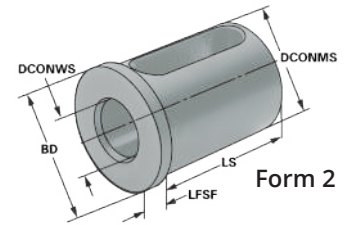

Form 2



Bestell-Nr. Order no. Référence	Form form forme	DCONMS	DCONWS	LS	LFSF	BD	OAL
709.25.06	1	25	6	46	5	29	51
709.25.08	1	25	8	46	5	29	51
709.25.10	1	25	10	46	5	29	51
709.25.12	1	25	12	46	5	29	51
709.25.14	1	25	14	46	5	29	51
709.25.16	2	25	16	46	5	29	51
709.25.18	2	25	18	46	5	29	51
709.25.20	2	25	20	46	5	29	51
709.32.06	1	32	6	55	5	36	60
709.32.08	1	32	8	55	5	36	60
709.32.10	1	32	10	55	5	36	60
709.32.12	1	32	12	55	5	36	60
709.32.14	1	32	14	55	5	36	60
709.32.16	2	32	16	55	5	36	60
709.32.18	2	32	18	55	5	36	60
709.32.20	2	32	20	55	5	36	60
709.32.25	2	32	25	55	5	36	60
709.40.06	1	40	6	71	5	44	76
709.40.08	1	40	8	71	5	44	76
709.40.10	1	40	10	71	5	44	76
709.40.12	1	40	12	71	5	44	76
709.40.14	1	40	14	71	5	44	76
709.40.16	2	40	16	71	5	44	76
709.40.18	2	40	18	71	5	44	76
709.40.20	2	40	20	71	5	44	76
709.40.25	2	40	25	71	5	44	76
709.40.32	2	40	32	71	5	44	76

Hinweis: Geeignet für Innenkühlung (nicht geschlitzt)
Note: Suitable for through-coolant (not slotted)
Observation: Convenable pour arrosage interne (non fendu)



10.104



Reduction sleeves set for boring bar holders form E2
 Douilles de réduction jeux pour barres d'alésage forme E2

(DIN 69880)



Verwendung:
 Reduzierung zum Spannen von Werkzeugen mit Zylinderschaft, wie z. B. Feindreh-Bohrstangen.

Application:
 Reduction for mounting tools with straight-shank, such as precision boring bars.

Application:
 Réduction pour le serrage d'outils avec queue cylindrique, p. ex. barres d'alésage pour tournage de finition.

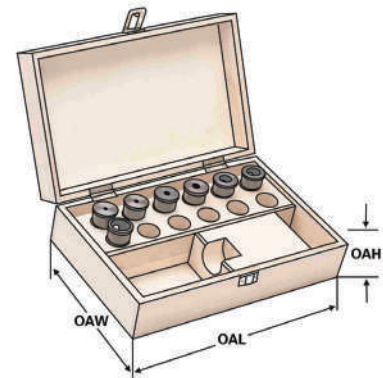

Bestell-Nr. Order no. Référence	Abmessung Size Dimension	OAL	OAW	OAH
701.709.25-S	Ø 25 Set 6 St. 06-08-10-12-16-20	360	235	70
701.709.32-S	Ø 32 Set 7 St. 06-08-10-12-16-20-25	360	235	70
701.709.40-S	Ø 40 Set 8 St. 06-08-10-12-16-20-25-32	360	235	70





Verwendung:

Zur Aufnahme von Werkzeugen mit Morsekegelschaft und Austreibblappen nach DIN 228-1 Form B.

Application:

For holding tools with Morse taper shank and tang according to DIN 228-1 form B.

Application:

Pour le serrage d'outils avec queue cône Morse et tenon suivant DIN 228-1 forme B.

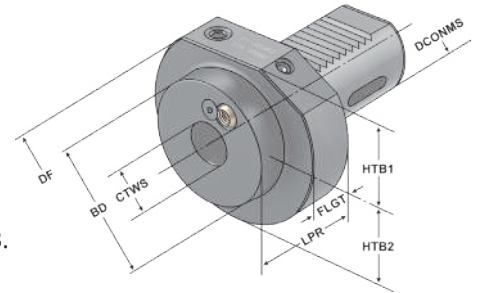

Bestell-Nr. Order no. Référence	Abmessung Size Dimension	DCONMS	CTWS	BD	DF	LPR	FLGT	HTB1	HTB2
169.07.01	F1 - 16 × MK 1	16	1	32	40	32	13	18	18
209.07.01	F1 - 20 × MK 1	20	1	-	50	23	-	22	23
209.07.02	F1 - 20 × MK 2	20	2	40	50	90	-	22	23
259.07.01	F1 - 25 × MK 1	25	1	-	58	23	-	25	25
259.07.02	F1 - 25 × MK 2	25	2	-	58	27	-	25	25
309.07.01	F1 - 30 × MK 1	30	1	-	68	27	-	28	30
309.07.02	F1 - 30 × MK 2	30	2	-	68	27	-	28	30
309.07.03	F1 - 30 × MK 3	30	3	58	68	75	22	28	30
409.07.02	F1 - 40 × MK 2	40	2	55	83	36	22	32,5	50,5
409.07.03	F1 - 40 × MK 3	40	3	55	83	36	22	32,5	50,5
409.07.04	F1 - 40 × MK 4	40	4	68	83	80	22	32,5	50,5
509.07.02	F1 - 50 × MK 2	50	2	55	98	36	30	35	49
509.07.03	F1 - 50 × MK 3	50	3	58	98	36	30	35	49
509.07.04	F1 - 50 × MK 4	50	4	68	98	50	30	35	49
509.07.05	F1 - 50 × MK 5	50	5	98	98	168	-	35	49

Ausführung: Mit einstellbaren Kugelspritzdüsen
Version: With adjustable spray nozzles
Version: Avec gicleurs ajustables

Hinweis: DCONMS 30, 40 und 50 werden mit einer Kugelspritzdüse geliefert.

Note: DCONMS 30, 40 and 50 are supplied with a ball spray nozzle.

Observation: Les DCONMS 30, 40 et 50 sont livrés avec une buse de pulvérisation à bille.

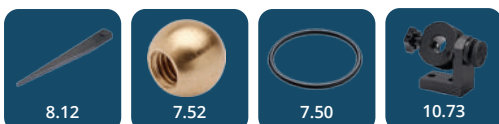



Verwendung:

Zur Aufnahme von Werkzeugen mit Zylinderschaft nach DIN 1835 Form A+B+E und DIN 6535 Form HA+HB+HE (größer Ø 20 mm nur mit Reduzierung).

Application:

For mounting straight-shank tools acc. DIN 1835 form A+B+E and DIN 6535 form HA+HB+HE (larger than Ø 20 mm only with reduction sleeve).

Application:

Pour le serrage d'outils avec queue cylindrique suivant DIN 1835 forme A+B+E et DIN 6535 forme HA+HB+HE (à partir de Ø 20 mm seulement avec réduction).

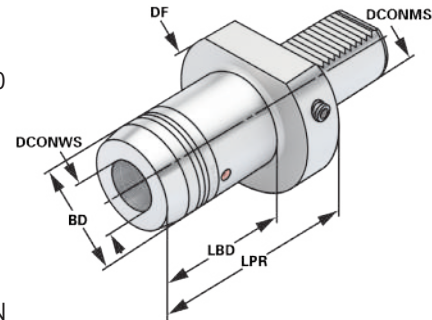

Bestell-Nr. Order no. Référence	Abmessung Size Dimension	DCONMS	DCONWS	BD	LPR	LBD	DF	LSCX	ADJRGA
309.H12	30 - 12	30	12	32	54	38	68	47	10
309.H20	30 - 20	30	20	42	89	73	68	52	10
409.H12	40 - 12	40	12	32	60	38	83	47	10
409.H20	40 - 20	40	20	42	95	73	83	52	10

LSCX = Einspannlänge, max. ADJRGA = Verstellweg, max.
LSCX = Clamping depth, max. ADJRGA = Length adjustment range, max.
LSCX = Profondeur d'insertion, max. ADJRGA = Course de réglage, max.

Lieferumfang: Ohne Spanschlüssel
Delivery: Without wrench
Livraison: Sans clé de serrage



Spannkraft-Prüfgerät für Hydrodehnspannfutter - Seite 12.59
Clamping force proofing instrument for hydraulic chucks - page 12.59
Appareil de contrôle des forces de serrage pour mandrin expansibles hydrauliques - page 12.59





Verwendung:
Zum Verschließen der Aufnahmebohrung
am Werkzeugrevolver.

Application:
For sealing the spindle of the turret.

Application:
Pour boucher la broche du tour.

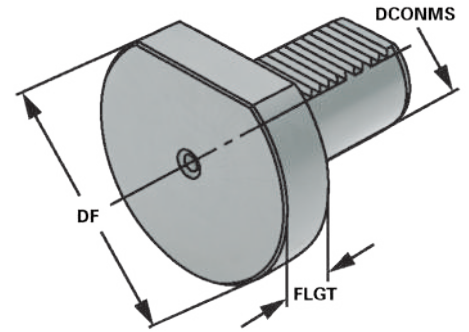

DIN ISO
10889

Z2

Bestell-Nr. Order no. Référence	Abmessung Size Dimension	DCONMS	DF	FLGT
169.29.13	Z2 - 16 × 13	16	40	13
209.29.16	Z2 - 20 × 16	20	50	16
259.29.16	Z2 - 25 × 16	25	58	16
309.29.20	Z2 - 30 × 16	30	68	16
409.29.20	Z2 - 40 × 20	40	83	20
509.29.20	Z2 - 50 × 20	50	98	20





Verwendung:
Zum Verschließen der Aufnahmebohrung
am Werkzeugrevolver.

Application:
For sealing the spindle of the turret.

Application:
Pour boucher la broche du tour.

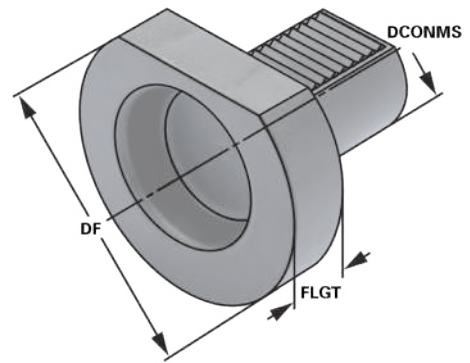
DIN ISO
10889

Z2

Bestell-Nr. Order no. Référence	Abmessung Size Dimension	DCONMS	DF	FLGT
169.30.13	Z2 - 16 × 13	16	40	13
209.30.16	Z2 - 20 × 16	20	50	16
259.30.16	Z2 - 25 × 16	25	58	16
309.30.16	Z2 - 30 × 16	30	68	16
409.30.20	Z2 - 40 × 20	40	83	20
509.30.20	Z2 - 50 × 20	50	98	20





Verwendung:
Zur Aufnahme von Werkzeugen mit Zylinderschaft.

Application:
For mounting tools with straight shank.

Application:
Pour le serrage d'outils avec queue cylindrique.

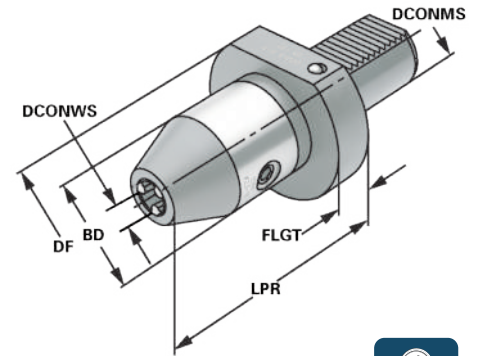

Bestell-Nr. Order no. Référence	DCONMS	DCONWS Spannbereich Capacity Capacité	BD	DF	LPR	FLGT	DRVS
209.15.13	20	1,0 – 13	50	50	90	17	6
309.15.13	30	1,0 – 13	50	68	93	22	6
309.15.16	30	2,5 – 16	50	68	98	22	6
409.15.13	40	1,0 – 13	50	83	93	22	6
409.15.16	40	2,5 – 16	50	83	98	22	6
509.15.13	50	1,0 – 13	50	98	101	30	6
509.15.16	50	2,5 – 16	50	98	106	30	6

7

Hinweis: Hohe Präzision und Rundlaufgenauigkeit von $\leq 0,03$ mm. Sichere Spannung des Werkzeuges durch mechanische Spannkraftverstärkung. Kein selbständiges Lösen der Spannung während der Bearbeitung bei Links- oder Rechtslauf. Spannen und Lösen mit Sechskantschlüssel.

Note: High precision and accurate concentricity of ≤ 0.03 mm. Secure gripping of the tool through mechanical amplification of the clamping force. No automatic slackening of the clamping force while machining with either clockwise or counter clockwise rotation. Clamping and releasing effected by means of an Allen wrench.

Observation: Précision élevée et exactitude de circularité de $\leq 0,03$ mm. Serrage sûr de l'outil grâce à l'amplification de la force de serrage. Pas de desserrage intempestif en cours d'usinage lors de la rotation la gauche ou la droite. Serrage et desserrage en utilisant un clé sur à fourche.

Lieferumfang: Ohne Spannschlüssel
Delivery: Without wrench
Livraison: Sans clé de serrage





CNC-Drill chucks with coolant supply via spray nozzles
Mandrins de perçage CNC avec arrosage par gicleurs

(DIN 69880)



Verwendung:
Zur Aufnahme von Werkzeugen mit Zylinderschaft.
Application:
For mounting tools with straight shanks.
Application:
Pour le serrage d'outils à queue cylindrique.

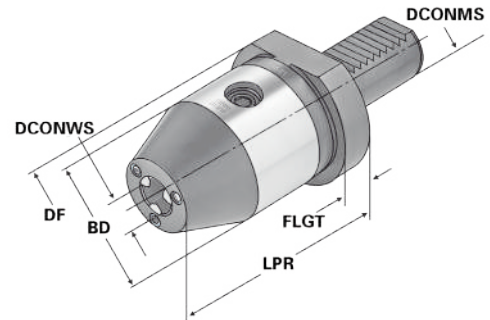

Bestell-Nr. Order no. Référence	DCONMS	DCONWS Spannbereich Capacity Capacité	BD	DF	LPR	FLGT	DRVS
169.15.10.K	16	1,0 – 13	57	40	87	5	6
209.15.10.K	20	1,0 – 13	57	50	87	5	6
259.15.13.K	25	1,0 – 13	57	58	87	15	6
309.15.13.K	30	1,0 – 13	57	68	87	22	6
309.15.16.K	30	2,5 – 16	57	68	92	22	6
409.15.13.K	40	1,0 – 13	57	83	87	22	6
409.15.16.K	40	2,5 – 16	57	83	92	22	6
509.15.13.K	50	1,0 – 13	57	98	92	20	6
509.15.16.K	50	2,5 – 16	57	98	96,9	20	6

Hinweis: Hohe Präzision und Rundlaufgenauigkeit von $\leq 0,03$ mm. Sichere Spannung des Werkzeuges durch mechanische Spannkraftverstärkung. Kein selbständiges Lösen der Spannung während der Bearbeitung bei Links- oder Rechtslauf. Spannen und Lösen mit Sechskantschlüssel.

Note: High precision and accurate concentricity of ≤ 0.03 mm. Secure gripping of the tool through mechanical amplification of the clamping force. No automatic slacking of the clamping force while machining with either clockwise or counter clockwise rotation. Clamping and releasing effected by means of an Allen wrench.

Observation: Précision élevée et exactitude de circularité de $\leq 0,03$ mm. Serrage sûr de l'outil grâce à l'amplification de la force de serrage. Pas de desserrage intempestif en cours d'usinage lors de la rotation la gauche ou la droite. Serrage et desserrage en utilisant un clé sur à fourche.

Lieferumfang: Ohne Spannschlüssel
Delivery: Without wrench
Livraison: Sans clé de serrage





Quick change tapping chucks **with length compensation on compression and expansion**

Mandrins de taraudage à changement rapide **avec compensation longitudinale à la compression et traction**



Verwendung:

Zur Aufnahme von Schnellwechsel-Einsätzen für Gewindebohrer.

Application:

For the chucking of Quick change taps for threading taps.

Application:

Pour le serrage des inserts de changement rapide pour tarauds.

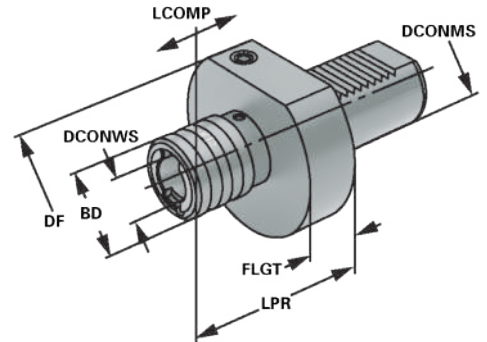

Bestell-Nr. Order no. Référence	DCONMS	Spannbereich Capacity Capacité	SZID	DF	LPR	BD	DCONWS	LCOMP	FLGT
209.16.12	20	M3 – M14	1	50	67	38	19	7	17
259.16.12	25	M3 – M14	1	58	55	38	19	7	18
309.16.12	30	M3 – M14	1	68	58	36	19	7	22
309.16.20	30	M5 – M22	2	68	81	53	31	12	22
409.16.12	40	M3 – M14	1	83	58	36	19	7	22
409.16.20	40	M5 – M22	2	83	81	53	31	12	22
509.16.12	50	M3 – M14	1	98	56	36	19	7	30
509.16.20	50	M5 – M22	2	98	80	53	31	12	30



10.42



10.43



10.48



10.49



10.50



7.50

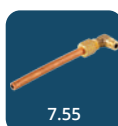

7.55



ohne Längenausgleich auf Druck und Zug

(DIN 69880)

Quick change tapping chucks without length compensation on compression and expansion

Mandrins de taraudage à changement rapide sans compensation longitudinale à la compression et traction



Verwendung:
Für Bearbeitungszentren mit Synchronspindel. Zur Aufnahme von Schnellwechsel-Einsätzen für Gewindebohrer.

Application:
On machining centres with synchronised spindles. For the chucking of Quick change taps for threading taps.

Application:
Sur centres d'usinage avec axe synchrone. Pour le serrage des inserts de changement rapide pour tarauds.

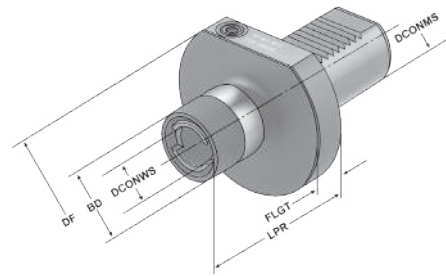

DIN ISO 10889

13.04

Bestell-Nr. Order no. Référence	DCONMS	Spannbereich Capacity Capacité	SZID	DF	LPR	BD	DCONWS	FLGT
309.16.12.1	30	M3 - M14	1	68	55	36	19	22
309.16.20.1	30	M5 - M22	2	68	77	53	31	22
409.16.12.1	40	M3 - M14	1	83	55	36	19	22
409.16.20.1	40	M5 - M22	2	83	77	53	31	22

7

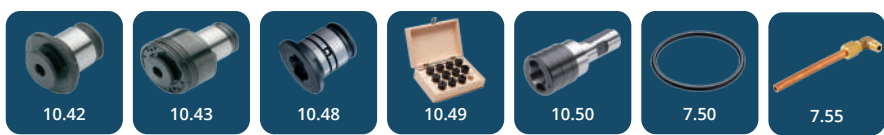

Soft blank fomr A1, rectangular
 Porte-outils ebauche forme A1, rectangle

(DIN 69880)



Verwendung:
 Zur Herstellung von Sonderwerkzeugen.
Application:
 For the manufacturing of special tools.
Application:
 Pour la fabrication d'outils spéciaux.

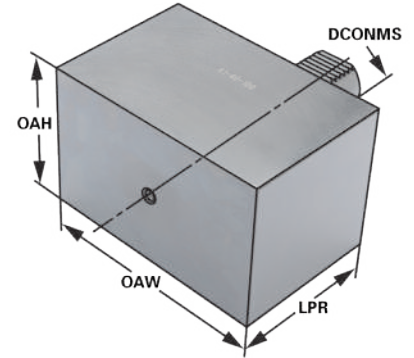

Bestell-Nr. Order no. Référence	Abmessung Size Dimension	DCONMS	LPR	OAH	OAW
169.17.12	A1 - 16 - 78 - 44 - 44	16	44	44	78
209.17.16	A1 - 20 - 100 - 60 - 65	20	65	60	100
259.17.16	A1 - 25 - 100 - 60 - 75	25	75	60	100
309.17.20	A1 - 30 - 130 - 76 - 85	30	85	76	130
409.17.25	A1 - 40 - 151 - 96 - 100	40	100	96	151
509.17.32	A1 - 50 - 160 - 120 - 125	50	125	120	160





Soft blank fomr A2, round

(DIN 69880)

Porte-outils ebauche forme A2, ronde



Verwendung:
Zur Herstellung von Sonderwerkzeugen.

Application:
For the manufacturing of special tools.

Application:
Pour la fabrication d'outils spéciaux.

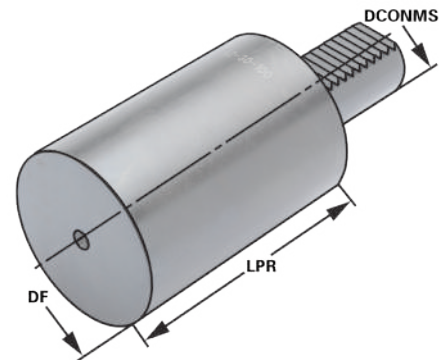

Bestell-Nr. Order no. Référence	Abmessung Size Dimension	DCONMS	DF	LPR
169.19.12	A2 - 16 - 40 - 60	16	40	60
209.19.16	A2 - 20 - 50 - 70	20	50	70
259.19.16	A2 - 25 - 50 - 80	25	58	80
259.19.17	A2 - 25 - 50 - 200	25	58	200
309.19.20	A2 - 30 - 68 - 100	30	68	100
309.19.21	A2 - 30 - 68 - 240	30	68	240
409.19.20	A2 - 40 - 83 - 120	40	83	120
409.19.21	A2 - 40 - 83 - 320	40	83	320
509.19.32	A2 - 50 - 98 - 135	50	98	135
509.19.33	A2 - 50 - 98 - 400	50	98	400





Verwendung:
Zur Abnahme von Werkzeugmaschinen gemäß ISO-Empfehlung R230 oder zur Überprüfung der Werkzeugspindel.

Application:
For the inspection of machine tools according to ISO recommendation R230 or for testing the tool spindle.

Application:
Pour l'inspection de machine-outils suite à la recommandation ISO R230 ou pour la vérification de la broche.

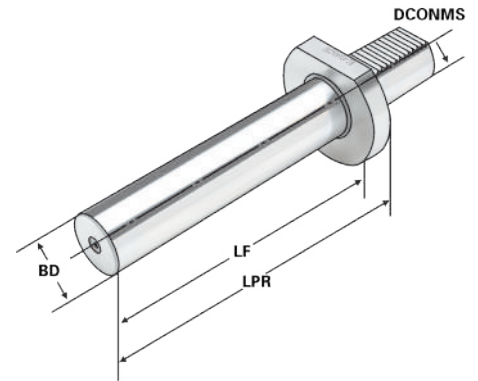

Bestell-Nr. Order no. Référence	Abmessung Size Dimension	DCONMS	BD	LPR	LF
169.18.30	16 - 30 - 120	16	30	120	107
209.18.40	20 - 40 - 150	20	40	150	132
259.18.40	25 - 40 - 150	25	40	150	135
309.18.40	30 - 40 - 200	30	40	230	214
409.18.40	40 - 40 - 200	40	40	200	184
509.18.40	50 - 40 - 200	50	40	200	185

Lieferumfang: Auslieferung mit Prüfprotokoll
Delivery: Delivery with test certificate
Livraison: Livraison avec rapport d'essais

7

Holzkasten für Kontrolldorne

Wooden box for test arbors
Coffret en bois pour mandrins de contrôle



Verwendung:
Zur Aufbewahrung von Kontrolldornen.

Application:
For the storage of test arbors.

Application:
Pour la conservation de mandrins de contrôle.



Bestell-Nr. Order no. Référence	Abmessung Size Dimension	für Kegelgrößen for cones pour cônes
701.18	460 × 130 × 115	VDI 16 / 20 / 25 / 30 / 40 / 50

Shims
Sous-plaquettes

(DIN 69880)



Verwendung:
Unterlegplatten für VDI Werkzeughalter
Application:
Shims for VDI toolholder
Application:
Assiettes pour porte-outils VDI

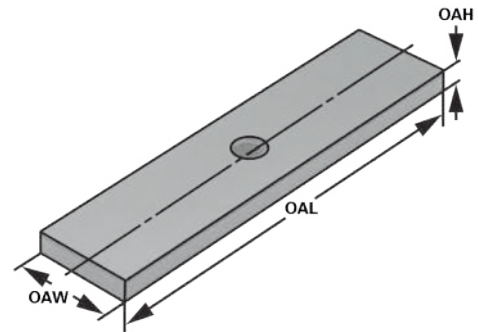

Bestell-Nr. Order no. Référence	OAW	OAH	OAL
209.16.01	14	4	54
259.16.01	13,5	4	49
309.20.01	16	4	69
409.25.01	20	5	84
509.32.01	23	7	99

7

O-Ringe

O-ring
Joints torique



Verwendung:
O-Ringe zum abdichten des VDI Schaftes
Application:
O-Rings for sealing VDI shanks
Application:
Joints toriques pour étancher des queues VDI

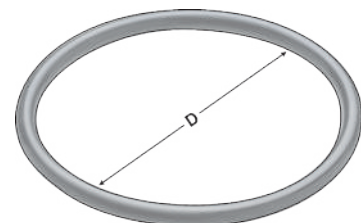

Bestell-Nr. Order no. Référence	D
Z.169.RING	16
Z.209.RING	20
Z.259.RING	25
Z.309.RING	30
Z.409.RING	40
Z.509.RING	50



Verwendung:

Spritzdüsen für Kühlmittelzufuhr für VDI
Werkzeughalter

Application:

Sprayer nozzles for cooling by VDI
toolholders

Application:

Gicleurs pour l'alimentation en refroidisse-
ment pour porte-outils VDI

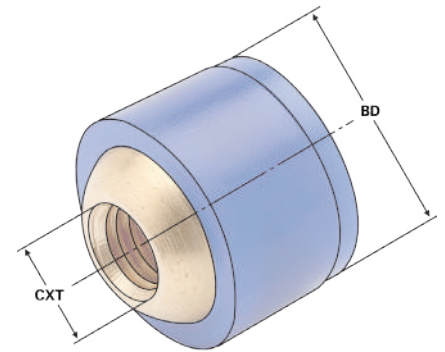

Bestell-Nr. Order no. Référence	BD	CXT
703.08	8	-
703.10	10	M4
703.12	12	M5
703.14	14	M6



Ball sprayer nozzles (brass)
Gicleurs (laiton)

(DIN 69880)



Verwendung:
Spritzdüsen für Kühlmittelzufuhr für VDI Werkzeughalter

Application:
Sprayer nozzles for cooling by VDI toolholders

Application:
Gicleurs pour l'alimentation en refroidissement pour porte-outils VDI

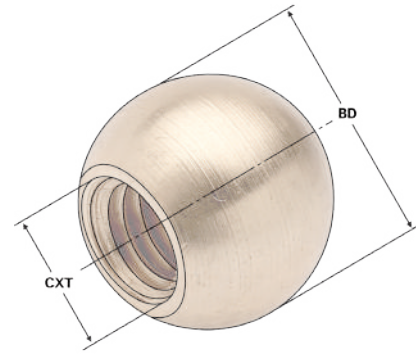

Bestell-Nr. Order no. Référence	BD	CXT	VDI
703.08.ME	8	M5	16
703.10.ME	10	M6	16 + 25 + 30 + 40
703.12.ME	12	M6	50
703.14 .ME	14	M8	-





Kugel mit Düse (Messing)

DIN ISO 10889

Ball sprayer nozzles with coolant tube (brass)
Bille avec gicleur (laiton)

(DIN 69880)



Verwendung:

Spritzdüsen für Kühlmittelzufuhr für VDI
Werkzeughalter

Application:

Sprayer nozzles for cooling by VDI toolholders

Application:

Gicleurs pour l'alimentation en refroidissement pour porte-outils VDI

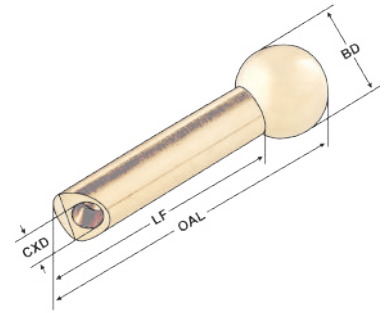

Bestell-Nr. Order no. Référence	BD	OAL	CXD	LF
Z.VDI.100.010	10	35	3	26
Z.VDI.100.012	12	38	4	28
Z.VDI.100.014	14	40	4	28

7

Kugelspritzdüsen (Messing)

Ball sprayer nozzles (brass)
Gicleurs (laiton)



Verwendung:

Spritzdüsen für Kühlmittelzufuhr für VDI
Werkzeughalter

Application:

Sprayer nozzles for cooling by VDI toolholders

Application:

Gicleurs pour l'alimentation en refroidissement pour porte-outils VDI

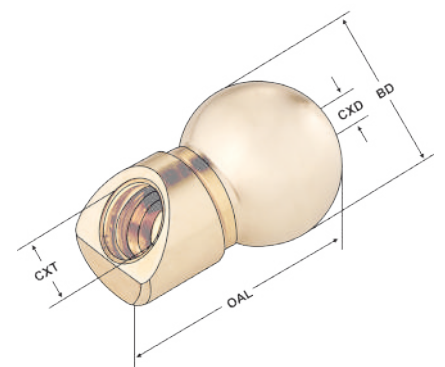

Bestell-Nr. Order no. Référence	BD	OAL	CXD	CXT
Z.VDI.200.010	10	15,8	5	M5
Z.VDI.200.012	12	19	5,5	M6
Z.VDI.200.014	14	19	6	M6



Verwendung:
Spritzdüsen für Kühlmittelzufuhr für VDI
Werkzeughalter

Application:
Sprayer nozzles for cooling by VDI toolholders

Application:
Gicleurs pour l'alimentation en refroidissement pour porte-outils VDI

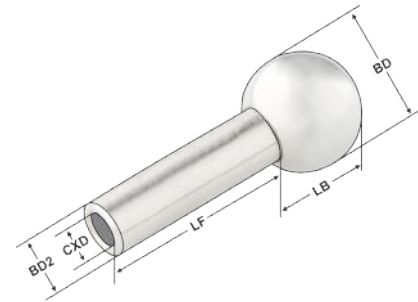

Bestell-Nr. Order no. Référence	BD	LB	LF	BD2	CXD
Z.VDI.300.010	10	8,5	10	6	4
Z.VDI.300.020	10	8,5	20	6	4
Z.VDI.300.040	10	8,5	40	6	4
Z.VDI.310.010	12	10,5	10	6	4
Z.VDI.310.020	12	10,5	20	6	4
Z.VDI.310.040	12	10,5	40	6	4

Material: Edelstahl AISI 304
Material: *Stainless steel AISI 304*
Matériel: Acier inoxydable AISI 304



Einschraub Kühlmittel Düse

Screw-in coolant nozzle
Gicleur a visser



Verwendung:
Spritzdüsen für Kühlmittelzufuhr für VDI
Werkzeughalter

Application:
Sprayer nozzles for cooling by VDI toolholders

Application:
Gicleurs pour l'alimentation en refroidissement pour porte-outils VDI

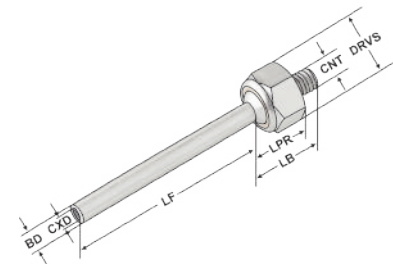

Bestell-Nr. Order no. Référence	CXD	BD	CNT	DRVS	LB	LF	LPR
Z.VDI.400.015	3	5	M5	14	16	15	10
Z.VDI.400.050	3	5	M5	14	16	50	10
Z.VDI.400.100	3	5	M5	14	16	100	10
Z.VDI.410.015	3	5	M6	14	16	15	10
Z.VDI.410.050	3	5	M6	14	16	50	10
Z.VDI.410.100	3	5	M6	14	16	100	10
Z.VDI.420.015	3	5	1/8"	14	16	15	10

Material: Edelstahl AISI 304
Material: *Stainless steel AISI 304*
Matériel: Acier inoxydable AISI 304



Kühlmittelrohr (Kupfer)

DIN ISO 10889

Coolant tube (copper)
Canule de lubrification (cuivre)

(DIN 69880)



Verwendung:
Kühlmittelrohr für Kühlmittelzufuhr für VDI Werkzeughalter
Application:
Coolant tube for cooling by VDI toolholders
Application:
Canule de lubrification pour l'alimentation en refroidissement pour porte-outils VDI

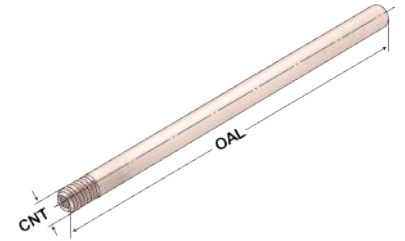

Bestell-Nr. Order no. Référence	OAL	CNT	Ø
Z.VDI.700.200	100	5	Ø 3mm
Z.VDI.700.100	100	6	Ø 3mm

7

Kühlmittelrohr (Messing) incl. 1/8" Adapter

Coolant tube (brass) incl. 1/8" adapter
Canule de lubrification (laiton) incl. 1/8" adaptateur



Verwendung:
Kühlmittelrohr für Kühlmittelzufuhr für VDI Werkzeughalter
Application:
Coolant tube for cooling by VDI toolholders
Application:
Canule de lubrification pour l'alimentation en refroidissement pour porte-outils VDI

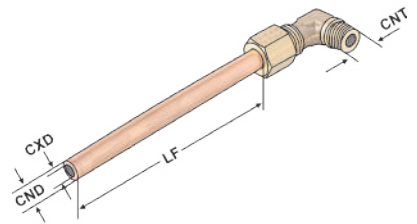

Bestell-Nr. Order no. Référence	CND	CNT	CXD	LF
Z.VDI.K	8	1/8"	4,5	150

Coolant tube
Canule de lubrification

(DIN 69880)



Verwendung:
Kühlmittelrohr für Kühlmittelzufuhr für
VDI Werkzeughalter

Application:
Coolant tube for cooling by VDI toolholders

Application:
Canule de lubrification pour l'alimentation
en refroidissement pour porte-outils VDI

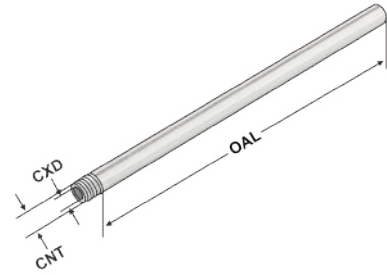

Bestell-Nr. Order no. Référence	CNT	CXD	OAL
Z.VDI.710.015	M4	2	15
Z.VDI.710.100	M4	2	100
Z.VDI.710.200	M4	2	200
Z.VDI.711.015	M5	3	15
Z.VDI.711.100	M5	3	100
Z.VDI.711.200	M5	3	200
Z.VDI.712.015	M6	4	15
Z.VDI.712.100	M6	4	100
Z.VDI.712.200	M6	4	200

Material: Edelstahl AISI 304

Material: *Stainless steel AISI 304*

Matériel: Acier inoxydable AISI 304

für CNC-Drehmaschinen mit HAAS/Doosan BMT-Schnittstelle

Static and power-driven tools for CNC lathes with HAAS/Doosan BMT interface

Porte-outils statiques ou rotatifs pour tours CNC avec HAAS/Doosan interface BMT

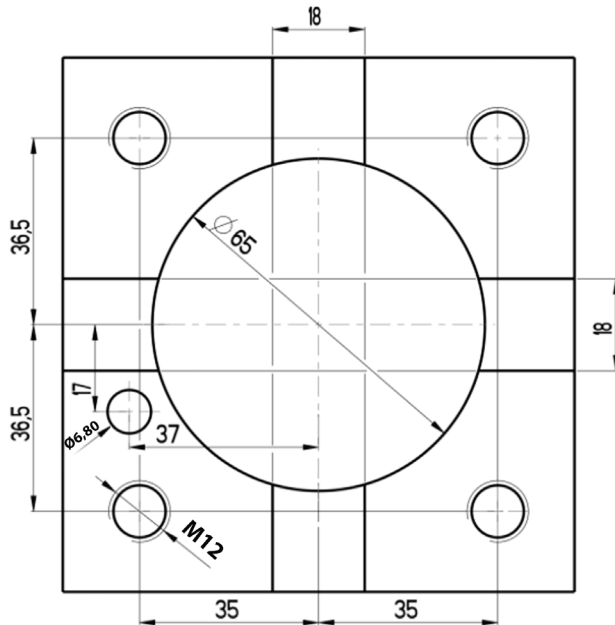

7

BMT	BMT65
Doosan	PUMA 2100/2600 (M,LM,MS,LMS) PUMA 2100/2600 (Y,LY,SY,LSY) PUMA 300 (M,MS,MB,MC) PUMA 3100 (M,LM,LY,XLM,XLY,ULM,ULY) PUMA MX2000/2500 PUMA MX2600 (T,ST), PUMA TT2500 (MS/SY) PUMA V400 (M) PUMA VT450 (M,2SP)
Haas	ST 20Y, ST 35Y, DS-30Y
Hwacheon	Cutex-240/Hi-TECH200/T2-Series Hi-TECH300/400 VT-450
Hyundai	L2100SY SKT-200/250TTSY SKT-250/300 (L,M) SKT-250/300 (MS)
Maxsin	BMT65
SMEC/Samsung	SL 25/SL 35
Tongtai	TMT2000
Victor	Vturn-A26 (YSCM)

ADINTMS (Adapterschnittstelle Maschinenrichtung): BMT driven turret interface -size BT65A

ADINTMS (Adaptive interface machine direction): BMT driven turret interface -size BT65A

ADINTMS (Interface adaptative direction machine): BMT driven turret interface -size BT65A

7.59	7.60	7.61	7.62
7.63	7.64	7.65	7.66
7.67 - 7.68	7.69 - 7.70	7.71	7.72

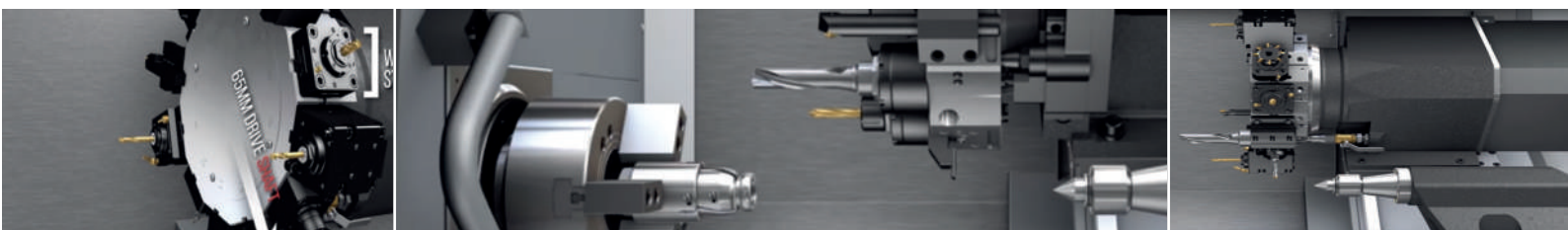



Toolholder with square-longitudinal receptacle doubled
Manche à outils avec porte-outils longitudinal carré double

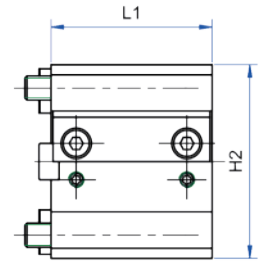
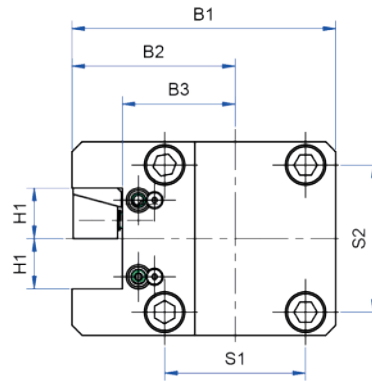
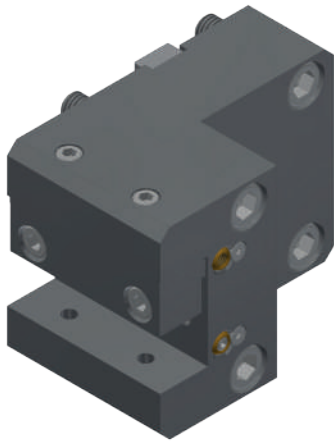

Bestell-Nr. Order no. Référence	H1	H2	B1	B2	B3	L1	S1	S2
AW.102.065.25.755	25	96	131	81	56	80	70	73

7

BMT	BMT65
Doosan	PUMA 2100/2600 (M,LM,MS,LMS) PUMA 2100/2600 (Y,LY,SY,LSY) PUMA 300 (M,MS,MB,MC) PUMA 3100 (M,LM,LY,XLM,XLY,ULM,ULY) PUMA MX2000/2500 PUMA MX2600 (T,ST), PUMA TT2500 (MS/SY) PUMA V400 (M) PUMA VT450 (M,2SP)
Haas	ST 20Y, ST 35Y, DS-30Y
Hwacheon	Cutex-240/Hi-TECH200/T2-Series Hi-TECH300/400 VT-450
Hyundai	L2100SY SKT-200/250TTSY SKT-250/300 (L,M) SKT-250/300 (MS)
Maxsin	BMT65
SMEC/Samsung	SL 25/SL 35
Tongtai	TMT2000
Victor	Vturn-A26 (YSCM)

Toolholder with square-multi-receptacle

Manche à outils avec porte-outils multiple carré

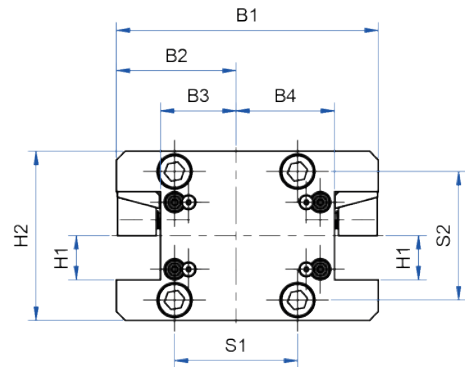
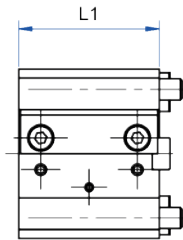
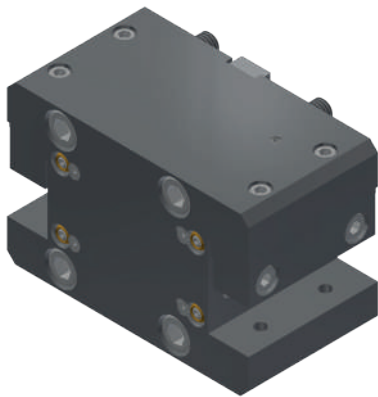

Bestell-Nr. Order no. Référence	H1	H2	B1	B2	B3	B4	L1	S1	S2
AW.103.065.25.755	25	96	149	68	43	56	80	70	73



BMT	BMT65
Doosan	PUMA 2100/2600 (M,LM,MS,LMS) PUMA 2100/2600 (Y,LY,SY,LSY) PUMA 300 (M,MS,MB,MC) PUMA 3100 (M,LM,LY,XLM,XLY,ULM,ULY) PUMA MX2000/2500 PUMA MX2600 (T,ST), PUMA TT2500 (MS/SY) PUMA V400 (M) PUMA VT450 (M,2SP)
Haas	ST 20Y, ST 35Y, DS-30Y
Hwacheon	Cutex-240/Hi-TECH200/T2-Series Hi-TECH300/400 VT-450
Hyundai	L2100SY SKT-200/250TTSY SKT-250/300 (L,M) SKT-250/300 (MS)
Maxsin	BMT65
SMEC/Samsung	SL 25/SL 35
Tongtai	TMT2000
Victor	Vturn-A26 (YSCM)



Toolholder with square-multi-receptacle
Manche à outils avec porte-outils multiple carré

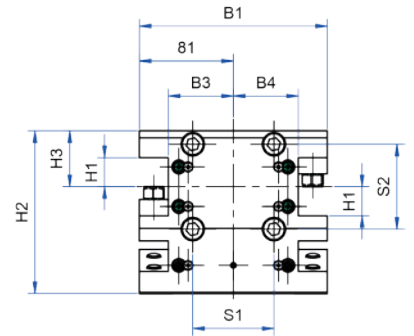
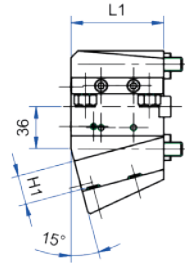
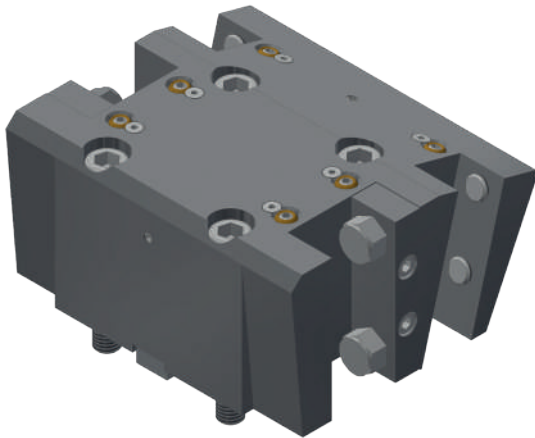

Bestell-Nr. Order no. Référence	H1	H2	H3	B1	B2	B3	B4	L1	S1	S2
AW.103.065.25.756	25	139,873	48	162	81	56	56	80	70	73

7

BMT	BMT65
Doosan	PUMA 2100/2600 (M,LM,MS,LMS) PUMA 2100/2600 (Y,LY,SY,LSY) PUMA 300 (M,MS,MB,MC) PUMA 3100 (M,LM,LY,XLM,XLY,ULM,ULY) PUMA MX2000/2500 PUMA MX2600 (T,ST), PUMA TT2500 (MS/SY) PUMA V400 (M) PUMA VT450 (M,2SP)
Haas	ST 20Y, ST 35Y, DS-30Y
Hwacheon	Cutex-240/Hi-TECH200/T2-Series Hi-TECH300/400 VT-450
Hyundai	L2100SY SKT-200/250TTSY SKT-250/300 (L,M) SKT-250/300 (MS)
Maxsin	BMT65
SMEC/Samsung	SL 25/SL 35
Tongtai	TMT2000
Victor	Vturn-A26 (YSCM)

Toolholder with square-multi-receptacle

Manche à outils avec porte-outils multiple carré

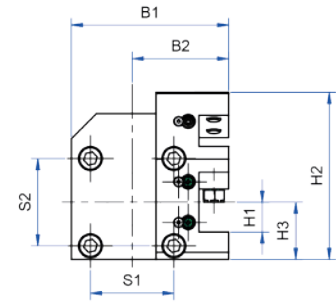
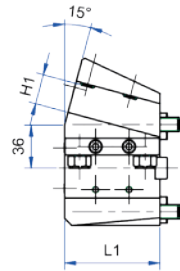
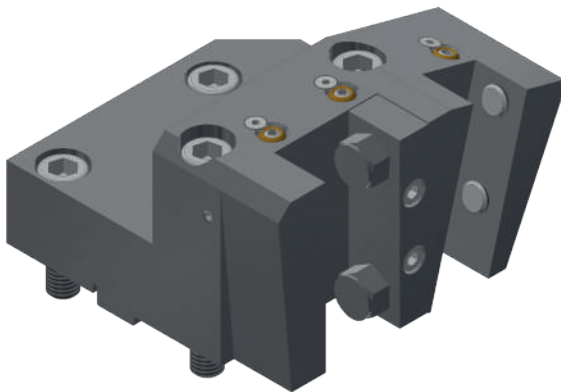

Bestell-Nr. Order no. Référence	H1	H2	H3	B1	B2	L1	S1	S2
AW.103.065.25.753	25	139,873	48	132	81	80	70	73

BMT	BMT65
Doosan	PUMA 2100/2600 (M,LM,MS,LMS) PUMA 2100/2600 (Y,LY,SY,LSY) PUMA 300 (M,MS,MB,MC) PUMA 3100 (M,LM,LY,XLM,XLY,ULM,ULY) PUMA MX2000/2500 PUMA MX2600 (T,ST), PUMA TT2500 (MS/SY) PUMA V400 (M) PUMA VT450 (M,2SP)
Haas	ST 20Y, ST 35Y, DS-30Y
Hwacheon	Cutex-240/Hi-TECH200/T2-Series Hi-TECH300/400 VT-450
Hyundai	L2100SY SKT-200/250TTSY SKT-250/300 (L,M) SKT-250/300 (MS)
Maxsin	BMT65
SMEC/Samsung	SL 25/SL 35
Tongtai	TMT2000
Victor	Vturn-A26 (YSCM)



Front cut-off toolholder

Porte-outils de tronçonnage frontal

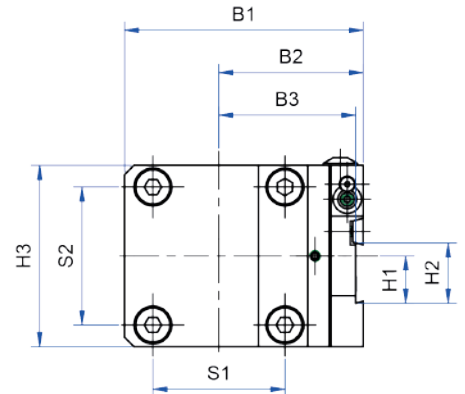
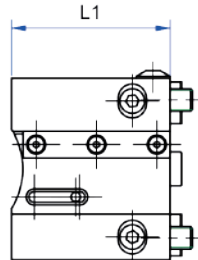
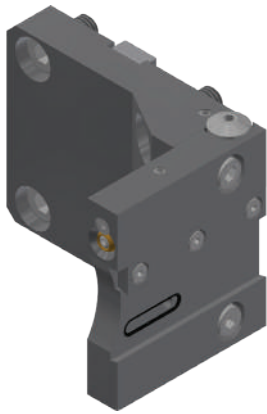

Bestell-Nr. Order no. Référence	H1	H2	H3	B1	B2	B3	L1	S1	S2
AW.105.065.26.753	25	32	96	126,5	76,5	72,5	84	70	73

7

BMT	BMT65
Doosan	PUMA 2100/2600 (M,LM,MS,LMS) PUMA 2100/2600 (Y,LY,SY,LSY) PUMA 300 (M,MS,MB,MC) PUMA 3100 (M,LM,LY,XLM,XLY,ULM,ULY) PUMA MX2000/2500 PUMA MX2600 (T,ST), PUMA TT2500 (MS/SY) PUMA V400 (M) PUMA VT450 (M,2SP)
Haas	ST 20Y, ST 35Y, DS-30Y
Hwacheon	Cutex-240/Hi-TECH200/T2-Series Hi-TECH300/400 VT-450
Hyundai	L2100SY SKT-200/250TTSY SKT-250/300 (L,M) SKT-250/300 (MS)
Maxsin	BMT65
SMEC/Samsung	SL 25/SL 35
Tongtai	TMT2000
Victor	Vturn-A26 (YSCM)



Cylindrical shank receptacle
Support de tige cylindrique

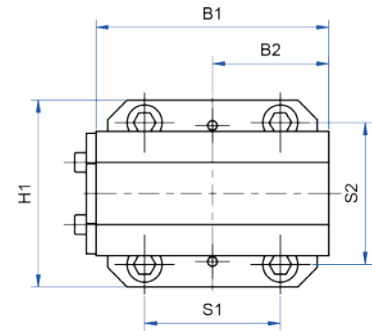
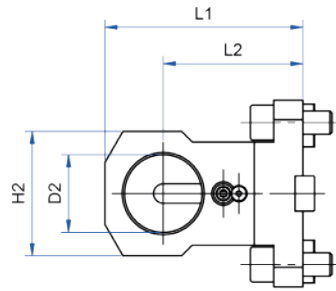
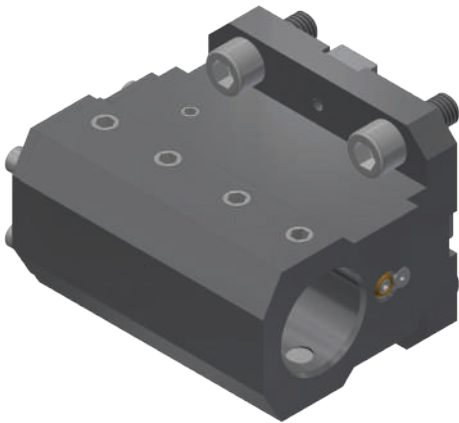

Bestell-Nr. Order no. Référence	D2	H1	H2	B1	B2	L1	L2	S1	S2
AW.107.265.40.750	40	96	64	120	60	102	72	70	73



BMT	BMT65
Doosan	PUMA 2100/2600 (M,LM,MS,LMS) PUMA 2100/2600 (Y,LY,SY,LSY) PUMA 300 (M,MS,MB,MC) PUMA 3100 (M,LM,LY,XLM,XLY,ULM,ULY) PUMA MX2000/2500 PUMA MX2600 (T,ST), PUMA TT2500 (MS/SY) PUMA V400 (M) PUMA VT450 (M,2SP)
Haas	ST 20Y, ST 35Y, DS-30Y
Hwacheon	Cutex-240/Hi-TECH200/T2-Series Hi-TECH300/400 VT-450
Hyundai	L2100SY SKT-200/250TTSY SKT-250/300 (L,M) SKT-250/300 (MS)
Maxsin	BMT65
SMEC/Samsung	SL 25/SL 35
Tongtai	TMT2000
Victor	Vturn-A26 (YSCM)





Cylindrical shank receptacle
Support de tige cylindrique

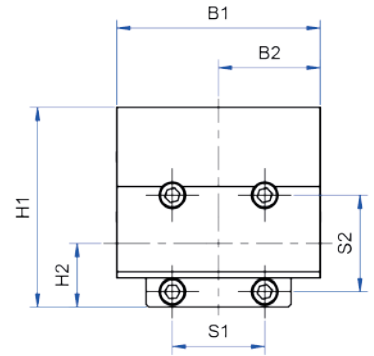
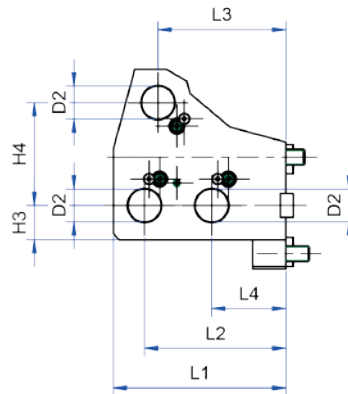

Bestell-Nr. Order no. Référence	D2	H1	H2	H3	H4	B1	B2	L1	L2	L3	L4	S1	S2
AW.107.265.25.756	25	151	48	26	77,82	154	77	130,5	107	96,755	56	70	73

7

BMT	BMT65
Doosan	PUMA 2100/2600 (M,LM,MS,LMS) PUMA 2100/2600 (Y,LY,SY,LSY) PUMA 300 (M,MS,MB,MC) PUMA 3100 (M,LM,LY,XLM,XLY,ULM,ULY) PUMA MX2000/2500 PUMA MX2600 (T,ST), PUMA TT2500 (MS/SY) PUMA V400 (M) PUMA VT450 (M,2SP)
Haas	ST 20Y, ST 35Y, DS-30Y
Hwacheon	Cutex-240/Hi-TECH200/T2-Series Hi-TECH300/400 VT-450
Hyundai	L2100SY SKT-200/250TTSY SKT-250/300 (L,M) SKT-250/300 (MS)
Maxsin	BMT65
SMEC/Samsung	SL 25/SL 35
Tongtai	TMT2000
Victor	Vturn-A26 (YSCM)



Cylindrical shank receptacle
Support de tige cylindrique

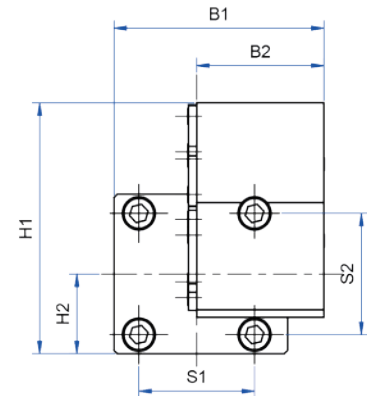
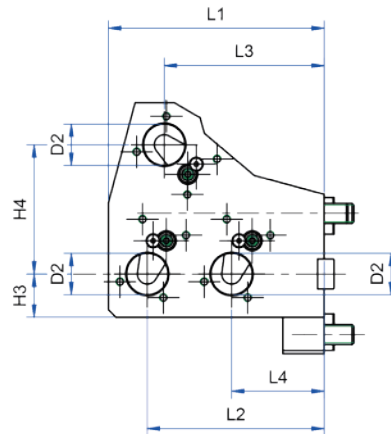
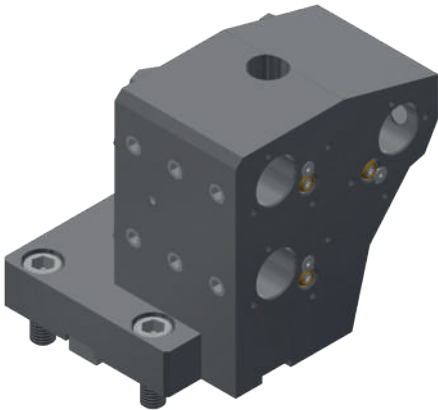

Bestell-Nr. Order no. Référence	D2	H1	H2	H3	H4	B1	B2	L1	L2	L3	L4	S1	S2
AW.107.265.25.753	25	151	48	26	77,82	127	77	130,5	107	96,755	56	70	73



BMT	BMT65
Doosan	PUMA 2100/2600 (M,LM,MS,LMS) PUMA 2100/2600 (Y,LY,SY,LSY) PUMA 300 (M,MS,MB,MC) PUMA 3100 (M,LM,LY,XLM,XLY,ULM,ULY) PUMA MX2000/2500 PUMA MX2600 (T,ST), PUMA TT2500 (MS/SY) PUMA V400 (M) PUMA VT450 (M,2SP)
Haas	ST 20Y, ST 35Y, DS-30Y
Hwacheon	Cutex-240/Hi-TECH200/T2-Series Hi-TECH300/400 VT-450
Hyundai	L2100SY SKT-200/250TTSY SKT-250/300 (L,M) SKT-250/300 (MS)
Maxsin	BMT65
SMEC/Samsung	SL 25/SL 35
Tongtai	TMT2000
Victor	Vturn-A26 (YSCM)





Axial drilling and milling head for external cooling

Tête d'alésage et de fraisage axiale pour refroidissement externe

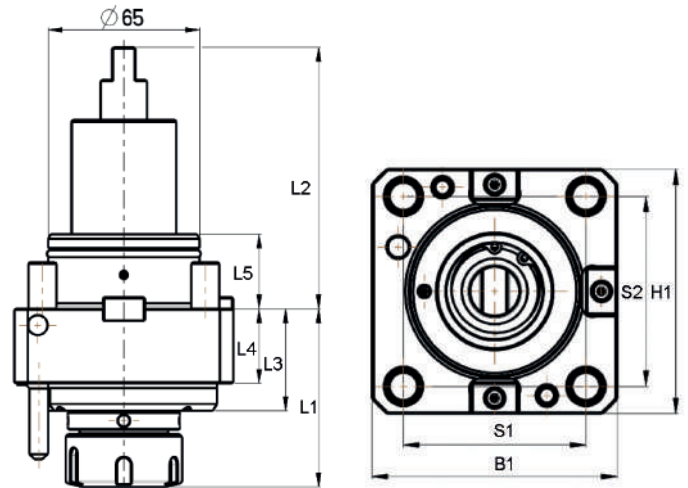
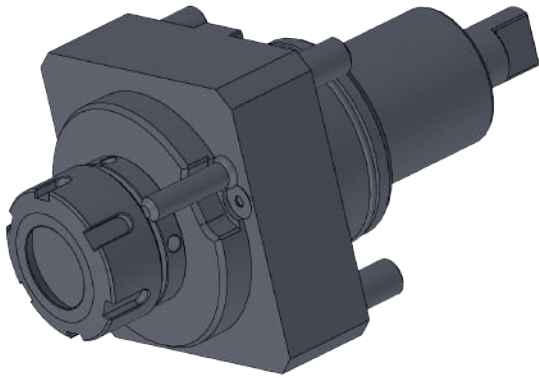

Bestell-Nr. Order no. Référence	B1	H1	S1	S2	L1	L2	L3	L4	L5	n max. min-1	T max. Nm
AW.221.065.20.751	94	94	70	73	76,3	112	43,7	32	32	6000	70

Typ: 470E | ER 32
 DCONWS: 3 - 20
 CP: 20 bar

7

BMT	BMT65
Doosan	PUMA 2100/2600 (M,LM,MS,LMS) PUMA 2100/2600 (Y,LY,SY,LSY) PUMA 300 (M,MS,MB,MC) PUMA 3100 (M,LM,LY,XLM,XLY,ULM,ULY) PUMA MX2000/2500 PUMA MX2600 (T,ST), PUMA TT2500 (MS/SY) PUMA V400 (M) PUMA VT450 (M,2SP)
Haas	ST 20Y, ST 35Y, DS-30Y
Hwacheon	Cutex-240/Hi-TECH200/T2-Series Hi-TECH300/400 VT-450
Hyundai	L2100SY SKT-200/250TTSY SKT-250/300 (L,M) SKT-250/300 (MS)
Maxsin	BMT65
SMEC/Samsung	SL 25/SL 35
Tongtai	TMT2000
Victor	Vturn-A26 (YSCM)





Axial drilling and milling head for internal and external cooling

Tête d'alésage et de fraisage axiale pour refroidissement interne et externe

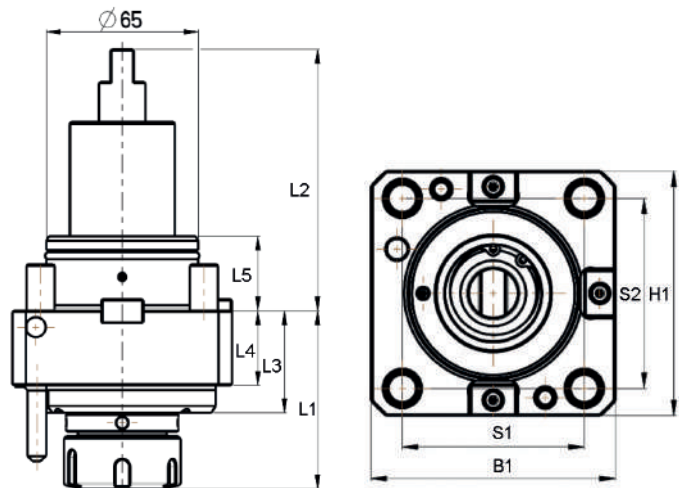
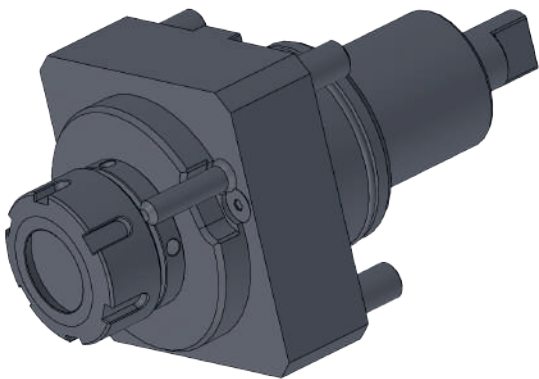

Bestell-Nr. Order no. Référence	B1	H1	S1	S2	L1	L2	L3	L4	L5	n max. min-1	T max. Nm
AW.221.065.20.756	94	94	70	73	76,3	112	43,7	32	32	6000	70

Typ: 470E | ER 32
 DCONWS: 3 - 20
 CP: 20 bar



BMT	BMT65
Doosan	PUMA 2100/2600 (M,LM,MS,LMS) PUMA 2100/2600 (Y,LY,SY,LSY) PUMA 300 (M,MS,MB,MC) PUMA 3100 (M,LM,LY,XLM,XLY,ULM,ULY) PUMA MX2000/2500 PUMA MX2600 (T,ST), PUMA TT2500 (MS/SY) PUMA V400 (M) PUMA VT450 (M,2SP)
Haas	ST 20Y, ST 35Y, DS-30Y
Hwacheon	Cutex-240/HI-TECH200/T2-Series HI-TECH300/400 VT-450
Hyundai	L2100SY SKT-200/250TTSY SKT-250/300 (L,M) SKT-250/300 (MS)
Maxsin	BMT65
SMEC/Samsung	SL 25/SL 35
Tongtai	TMT2000
Victor	Vturn-A26 (YSCM)



Radial drilling and milling head for external cooling
Tête d'alésage et de fraisage radiale pour refroidissement externe

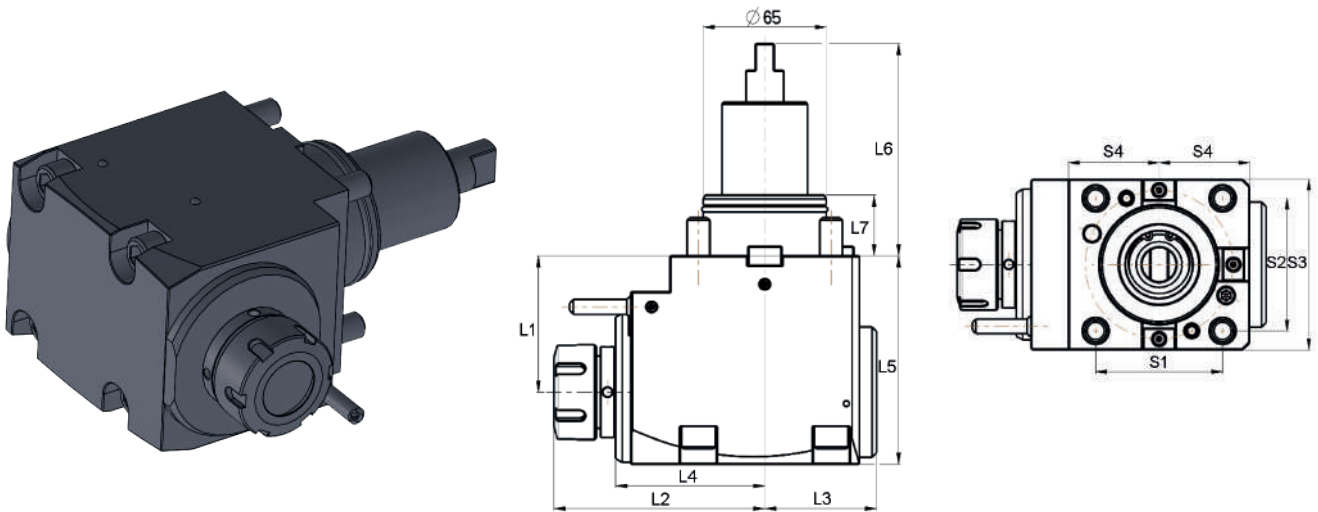

Doosan
HAAS
BMT 65
EC
ER 32
1:1

Bestell-Nr. Order no. Référence	S1	S2	S3	S4	L1	L2	L3	L4	L5	L6	L7	n max. min-1	T max. Nm
AW.221.265.20.751	70	73	94	50	72	111,3	59	78,7	110	112	32	6000	70

7

Typ: 470E | ER 32
DCONWS: 3 - 20
CP: 20 bar

BMT	BMT65
Doosan	PUMA 2100/2600 (M,LM,MS,LMS) PUMA 2100/2600 (Y,LY,SY,LSY) PUMA 300 (M,MS,MB,MC) PUMA 3100 (M,LM,LY,XLM,XLY,ULM,ULY) PUMA MX2000/2500 PUMA MX2600 (T,ST), PUMA TT2500 (MS/SY) PUMA V400 (M) PUMA VT450 (M,2SP)
Haas	ST 20Y, ST 35Y, DS-30Y
Hwacheon	Cutex-240/Hi-TECH200/T2-Series Hi-TECH300/400 VT-450
Hyundai	L2100SY SKT-200/250TTSY SKT-250/300 (L,M) SKT-250/300 (MS)
Maxsin	BMT65
SMEC/Samsung	SL 25/SL 35
Tongtai	TMT2000
Victor	Vturn-A26 (YSCM)





Axial drilling and milling head for internal and external cooling

Tête d'alésage et de fraisage axiale pour refroidissement interne et externe

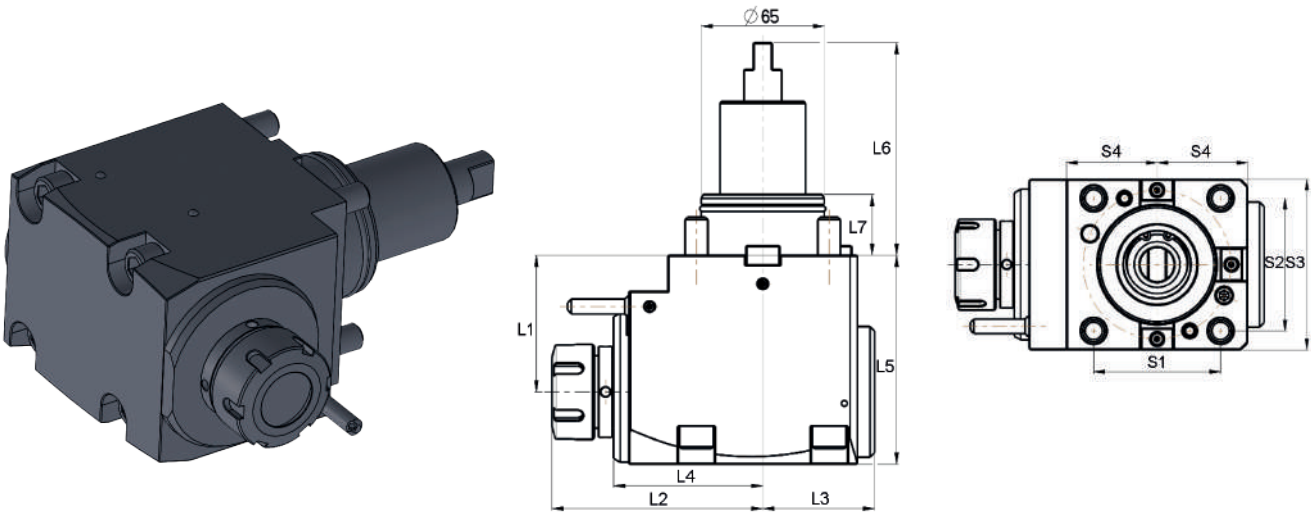

Doosan HAAS BMT 65 IC | EC ER 32 1:1

Bestell-Nr. Order no. Référence	S1	S2	S3	S4	L1	L2	L3	L4	L5	L6	L7	n max. min-1	T max. Nm
AW.221.265.20.756	70	73	94	50	72	111,3	59	78,7	110	112	32	6000	70

Typ: 470E | ER 32
 DCONWS: 3 - 20
 CP: 20 bar



BMT	BMT65
Doosan	PUMA 2100/2600 (M,LM,MS,LMS) PUMA 2100/2600 (Y,LY,SY,LSY) PUMA 300 (M,MS,MB,MC) PUMA 3100 (M,LM,LY,XLM,XLY,ULM,ULY) PUMA MX2000/2500 PUMA MX2600 (T,ST), PUMA TT2500 (MS/SY) PUMA V400 (M) PUMA VT450 (M,2SP)
Haas	ST 20Y, ST 35Y, DS-30Y
Hwacheon	Cutex-240/Hi-TECH200/T2-Series HI-TECH300/400 VT-450
Hyundai	L2100SY SKT-200/250TTSY SKT-250/300 (L,M) SKT-250/300 (MS)
Maxsin	BMT65
SMEC/Samsung	SL 25/SL 35
Tongtai	TMT2000
Victor	Vturn-A26 (YSCM)





ISO 15488 (DIN 6499) System ER

Collet chucks with straight shank with with clamping surface for collets ISO 15488 (DIN 6499) ER-system
Mandrins à pinces à queue cylindrique avec surface de serrage pour pinces ISO 15488 (DIN 6499) système ER

**Verwendung:**

Zur Aufnahme von Werkzeugen mit Zylinderschaft in Spannzangen.

Application:

For mounting straight-shank tools in collets.

Application:

Pour le serrage d'outils avec queue cylindrique dans des pinces de serrage.

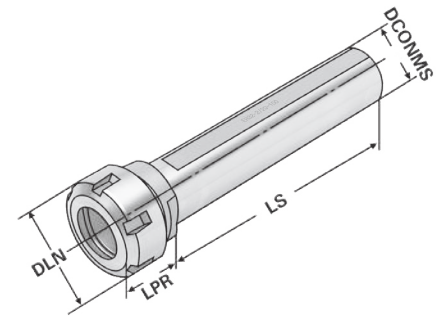

Bestell-Nr. Order no. Référence	DCONMS	DCONWS Spannbereich Capacity Capacité	Typ	LS	LPR	DLN	DRVS	CND	THID
120.02.04.10	16	1 - 10	426E ER 16	150	30	32	19	9	M10 x 1,5
120.02.04.16	20	1 - 16	430E ER 25	150	40	42	27	11	M12 x 1,5
120.02.04.20	32	2 - 20	470E ER 32	150	35	50	32	19	M20 x 1,5
120.02.04.20.1	40	2 - 20	470E ER 32	120	35	50	36	19	M20 x 1,5

Durchgangsbohrung für Innenkühlung vorhanden.

Through hole for internal cooling provided.

Trou débouchant disponible pour arrosage interne.

Lieferumfang: Inkl. Spannmutter
Delivery: Clamping nuts
Livraison: Ecrou de serrage

7

Spannfutter mit Zylinderschaft für Spannzangen

ISO 15488 (DIN 6499) System ER

Collet chucks with straight shank for collets ISO 15488 (DIN 6499) ER-system
Mandrins à pinces à queue cylindrique pour pinces ISO 15488 (DIN 6499) système ER

**Verwendung:**

Zur Aufnahme von Werkzeugen mit Zylinderschaft in Spannzangen.

Application:

For mounting straight-shank tools in collets.

Application:

Pour le serrage d'outils avec queue cylindrique dans des pinces de serrage.

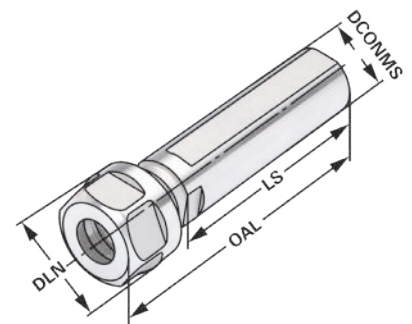

Bestell-Nr. Order no. Référence	DCONMS	DCONWS Spannbereich Capacity Capacité	Typ	DLN	LS	OAL	DRVS	CND	THID
120.02.A.07	20	1 - 07	4008E ER 11	19	50	67,5	17	7	-
120.02.A.07.1	20	1 - 07	4008E ER 11	19	70	87,5	17	7	-
120.02.A.10	20	1 - 10	426E ER 16	28	70	96,0	17	10	7/16" 20 UNF
120.02.A.13	25	1 - 13	428E ER 20	34	50	74,0	22	13	9/16" 18 UNF

Sechskantmutter
Hexagonal clamping nut
Écrous hexagonal

Durchgangsbohrung für Innenkühlung vorhanden.

Through hole for internal cooling provided.

Trou débouchant disponible pour arrosage interne.

Hook wrench with pin 45-50 | ER32 | 2-20 |
Clé à ergot rond 45-50 | ER32 | 2-20 |



Bestell-Nr. Order no. Référence	Spannbereich Capacity Capacité
AW.SE4550	45 - 50 (ER 32)

Spannschlüssel für Spannmuttern System ER

Wrenches for clamping nuts ER-system
Clés de serrage pour écrous de serrage système ER



Bestell-Nr. Order no. Référence	Spannbereich Capacity Capacité
02.20	2 - 20 (ER 32)

**WERKZEUGAUFNAHMEN
MK DIN 228-1 A / DIN 228-1 B**

**TOOLHOLDERS
MT DIN 228-1 A / DIN 228-1 B**

**PORTE-OUTILS
CM DIN 228-1 A / DIN 228-1 B**

DIN 228

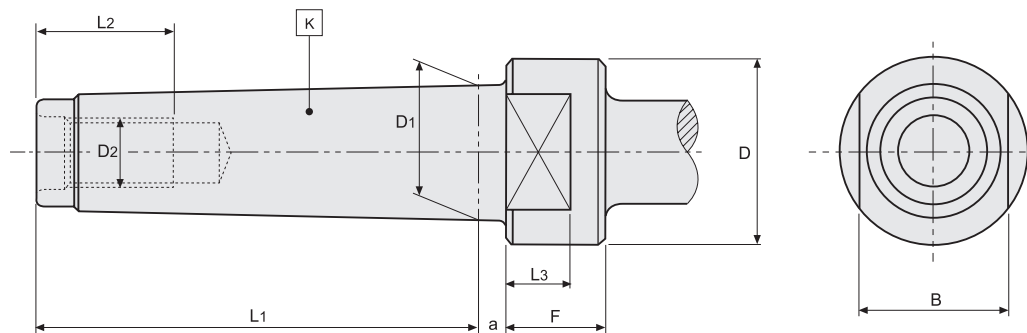

Toolholders Morse taper (MT) DIN 228-1 A
Porte-outils Cône Morse (CM) DIN 228-1 A

MK	L ₁ mm	L ₂ mm	L ₃ mm	D mm	D ₁ mm	D ₂ mm	F min mm	B d ₉ mm	a mm	DRVS
1	53,5	16	-	-	12,065	M6	-	-	3,5	-
2	64,0	24	-	-	17,780	M10	-	-	5,0	-
3	81,0	24	12	36	23,825	M12	18	24	5,0	24
4	102,5	32	15	43	31,267	M16	23	32	6,5	32
5	129,5	40	18	60	44,399	M20	28	45	6,5	45
6	182,0	47	25	84	63,348	M24	39	65	8,0	65

8

- Werkstoff:** Legierter Einsatzstahl mit einer Zugfestigkeit im Kern von min. 950 N/mm² Einsatzgehärtet HRC 60 ± 2 (HV 700 ± 50), Härtetiefe 0,8 mm ± 0,2 mm, brüniert und präzisionsgeschliffen.
- Material:** Alloyed case hardened steel, tensile strength in the core of min. 950 N/mm² Case hardened HRC 60 ± 2 (HV 700 ± 50), hardening depth 0.8 mm ± 0.2 mm, black-finished and precisely grinded.
- Matière:** Châssis d'allié en acier de cémentation. Résistance à la traction dans le noyau de min 950 N/mm² Trempé à HRC 60 ± 2 (HV 700 ± 50), profondeur de trempé 0,8 mm ± 0,2 mm, bruni et rectifié précisément.

Diese Norm stimmt weitgehend sachlich überein mit der von der International Organization for Standardization (ISO) herausgegebenen Internationalen Norm ISO 296

This norm largely corresponds to that of the international norm ISO 296 published by the International Organization for Standardization (ISO).

Cette norme correspond largement à celle de la norme internationale ISO 296 publiée par l'Organisation internationale de normalisation (ISO).



Index
Sommaire

8.05



8.06



8.07



8.08



8.09



8.10



8.11



8.12





DIN 6499 (ISO 15488) System ER

Collet chucks for collets DIN 6499 (ISO 15488) ER-system
Mandrins à pinces pour pinces DIN 6499 (ISO 15488) système ER



Verwendung:
Zur Aufnahme von Werkzeugen mit Zylinderschaft in Spannzangen.
Application:
For mounting straight-shank tools in collets.
Application:
Pour le serrage d'outils avec queue cylindrique dans des pinces de serrage.

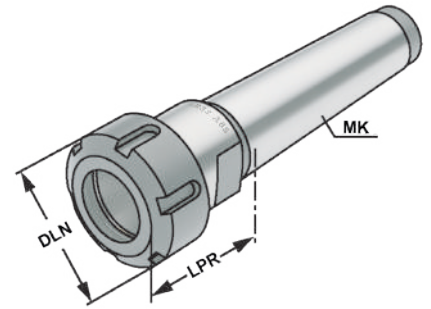

Bestell-Nr. Order no. Référence	MK MT CM	THSZMS	DCONWS Spannbereich Capacity Capacité	Typ	LPR	DLN	DRVS
108.02.01	MK 2	M10	1 – 10	426E ER 16	45	32	18
108.02.011	MK 2	M10	2 – 16	430E ER 25	50	42	18
108.02.012	MK 2	M10	2 – 20	470E ER 32	70	50	18
108.02.02	MK 3	M12	2 – 16	430E ER 25	56	42	24
108.02.03	MK 3	M12	2 – 20	470E ER 32	70	50	24
108.02.04	MK 4	M16	2 – 16	430E ER 25	63	42	32
108.02.05	MK 4	M16	2 – 20	470E ER 32	65	50	32
108.02.06	MK 5	M20	3 – 26	472E ER 40	86	63	45

Lieferumfang: Mit gewuchteter Spannmutter
Delivery: With balanced clamping nut
Livraison: Avec écrou de serrage équilibré

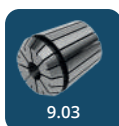

Combi shell mill holders DIN 6358
 Porte-fraises à double usage DIN 6358



Verwendung:
 Zur Aufnahme von Walzen-, Walzenstirnfräsern oder Messerköpfen mit Längs- oder Quernut.

Application:
 For mounting milling cutters with transverse or longitudinal groove.

Application:
 Pour le serrage de fraises à rainure transversale ou à rainure longitudinale.

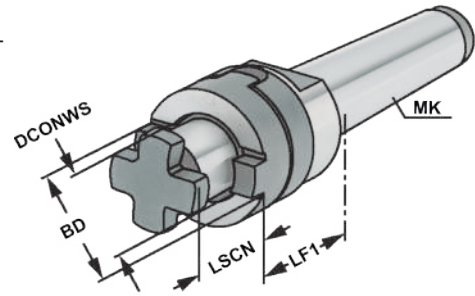

DIN 228
Form A
≤ 8µm
DIN 6358
h6

Bestell-Nr. Order no. Référence	MK MT CM	THSZMS	DCONWS	TDCON	LF1	LSC	BD	DRVS
108.10.20	MK 2	M10	16	h6	43	17	32	18
108.10.21	MK 2	M10	22	h6	43	19	40	18
108.10.30	MK 3	M12	16	h6	48	17	32	24
108.10.31	MK 3	M12	22	h6	48	19	40	24
108.10.32	MK 3	M12	27	h6	48	21	48	24
108.10.33	MK 3	M12	32	h6	48	24	58	24
108.10.40	MK 4	M16	16	h6	55	17	32	32
108.10.41	MK 4	M16	22	h6	55	19	40	32
108.10.42	MK 4	M16	27	h6	55	21	48	32
108.10.43	MK 4	M16	32	h6	55	24	58	32
108.10.50	MK 5	M20	22	h6	75	19	40	45
108.10.51	MK 5	M20	27	h6	75	21	48	45
108.10.52	MK 5	M20	32	h6	75	24	58	45
108.10.53	MK 5	M20	40	h6	75	27	70	45

Lieferumfang: Mit Fräseranzugsschraube, Mitnehmerring und Passfeder
Delivery: With tightening bolt, driving ring and feather key
Livraison: Avec vis de blocage, bague d'entraînement et clavette

8





auf Druck und Zug

Quick change tapping chucks with length compensation on compression and expansion

Mandrins de taraudage à changement rapide avec compensation longitudinale à la compression et traction



Verwendung:

Zur Aufnahme von Schnellwechsel-Einsätzen für Gewindebohrer.

Application:

For the chucking of Quick change taps for threading taps.

Application:

Pour le serrage des inserts de changement rapide pour tarauds.

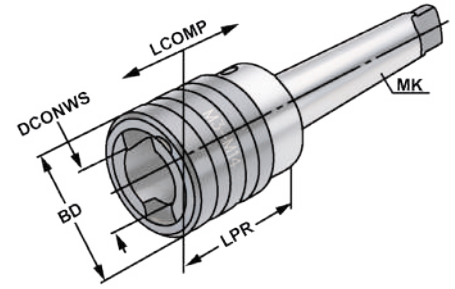

Bestell-Nr. Order no. Référence	MK MT CM	Spannbereich Capacity Capacité	SZID	DCONWS	LPR	BD	LCOMP
107.16.212	MK 2	M3 - M14	1	19	46	36	7
107.16.312	MK 3	M3 - M14	1	19	46	36	7
107.16.320	MK 3	M5 - M22	2	31	70	53	12
107.16.412	MK 4	M3 - M14	1	19	46	36	7
107.16.420	MK 4	M5 - M22	2	31	71	53	12
107.16.436	MK 4	M14 - M36	3	48	128	78	17,5





Reduction sleeves for tools with Morse taper shanks DIN 2185
 Douille de réductions pour outils avec cône Morse DIN 2185



Verwendung:
 Zur Aufnahme von Werkzeugen mit Morsekegelschaft
Application:
 For mounting tools with Morse taper shanks
Application:
 Pour le serrage d'outils avec cône Morse

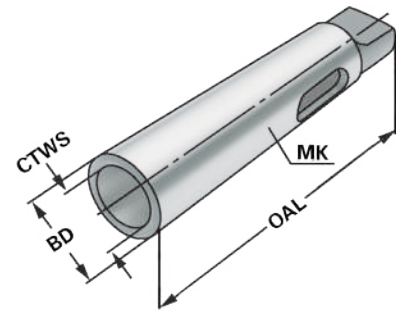

DIN 228
Form B
≤ 10µm
DIN 2185
AT5

Bestell-Nr. Order no. Référence	MK MT CM	TDCON	CTWS	BD	OAL
107.07.21	MK 2	AT5	MK 1	18,6	92
107.07.32	MK 3	AT5	MK 2	24,7	112
107.07.42	MK 4	AT5	MK 2	31,6	124
107.07.43	MK 4	AT5	MK 3	32,4	140
107.07.53	MK 5	AT5	MK 3	44,7	156
107.07.54	MK 5	AT5	MK 4	45,5	171
107.07.64	MK 6	AT5	MK 4	63,8	218
107.07.65	MK 6	AT5	MK 5	63,8	218

Ausführung: Ganz gehärtet, innen und außen geschliffen
Version: Entirely hardened, grinded on the inside and outside
Version: Entièrement trempé, rectifié à l'intérieur et à l'extérieur

Drill chuck adaptors DIN 238
 Arbres pour mandrins de perçage DIN 238



Verwendung:
 Zur Aufnahme von Bohrfuttern auf Bohrmaschinen, Drehmaschinen usw.

Application:
 For mounting drill chucks on drilling machines, turning lathes etc.

Application:
 Pour le serrage de mandrins de perçage sur des perceuses, tournettes etc.

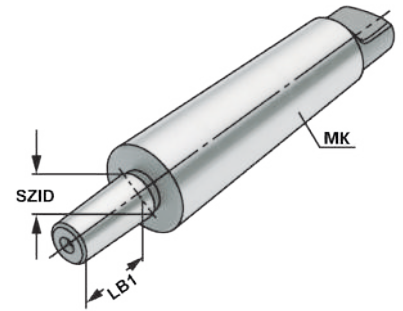

DIN 228	Form B	≤ 8µm	DIN 238	AT4
---------	--------	-------	---------	-----

Bestell-Nr. Order no. Référence	MK MT CM	SZID	LB1
107.14.12.02	MK 2	B12	12,06
107.14.12.03	MK 3	B12	12,06
107.14.12.04	MK 4	B12	12,06
107.14.02	MK 2	B16	29
107.14.03	MK 3	B16	29
107.14.04	MK 4	B16	29

Ausführung: Ganz gehärtet und geschliffen
Version: Entirely hardened and grinded
Version: Entièrement trempé et rectifié



CNC-Drill chucks for clockwise and counter clockwise rotation
Mandrins de perçage CNC pour rotation gauche-droite



Verwendung:
Zur Aufnahme von Werkzeugen mit Zylinderschaft.

Application:
For mounting tools with straight shanks.

Application:
Pour le serrage d'outils avec queue cylindrique.

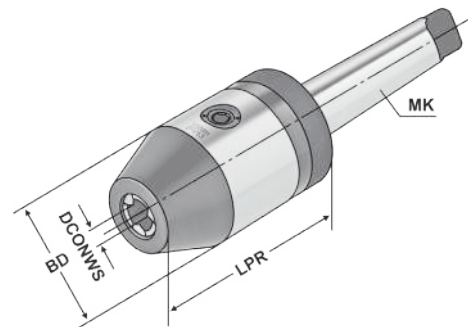

Bestell-Nr. Order no. Référence	MK MT CM	DCONWS Spannbereich Capacity Capacité	LPR	BD	DRVS
107.15.313	MK 3	1,0 – 13	98	50	6
107.15.316	MK 3	2,5 – 16	103	50	6
107.15.413	MK 4	1,0 – 13	100	50	6
107.15.416	MK 4	2,5 – 16	105	50	6

Hinweis: Hohe Präzision und Rundlaufgenauigkeit von $\leq 0,03$ mm. Sichere Spannung des Werkzeuges durch mechanische Spannkraftverstärkung. Kein selbständiges Lösen der Spannung während der Bearbeitung bei Links- oder Rechtslauf, sowie bei Spindelstop. Spannen und Lösen mit Sechskantschlüssel.

Note: High precision and accurate concentricity of ≤ 0.03 mm. Secure gripping of the tool through mechanical amplification of the clamping force. No automatic slackening of the clamping force while machining with either clockwise or counter clockwise rotation or on spindle stop. Clamping and releasing effected by means of an Allen wrench.

Observation: Précision élevée et exactitude de circularité de $\leq 0,03$ mm. Serrage sûr de l'outil grâce à l'amplification de la force de serrage. Pas de desserrage intempestif en cours d'usinage lors de la rotation la gauche ou la droite, de même qu'en cas d'arrêt de la broche. Serrage et desserrage en utilisant un clé sur à fourche.

Lieferumfang: Ohne Spanschlüssel
Delivery: Without wrench
Livraison: Sans clé de serrage





Drift tangs to screw in
Tenons à visser



Verwendung:

Zum Spannen und Austreiben von Werkzeugkegeln DIN 228-1 A in Werkzeugaufnahmen DIN 228-1 B.

Application:

*For mounting and drifting taper shanks
DIN 228-1 A in toolholders DIN 228-1 B.*

Application:

Pour le serrage et l'enlèvement de queues
DIN 228-1 A dans porte-outils DIN 228-1 B.

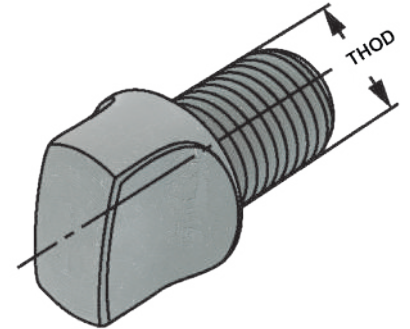

Bestell-Nr. Order no. Référence	MK MT CM	THOD
107.20.06	MK 1	M6
107.20.10	MK 2	M10
107.20.12	MK 3	M12
107.20.16	MK 4	M16
107.20.20	MK 5	M20



Drill drifts DIN 317 for cones DIN 228 B

Chasse-cônes DIN 317 pour cônes DIN 228 B



Verwendung:

Zum Austreiben von Werkzeugen mit Werkzeugkegeln DIN 228-1 B.

Application:

For drifting of tools with taper shanks DIN 228-1 B.

Application:

Pour l'enlèvement d'outils avec queues DIN 228-1 B.

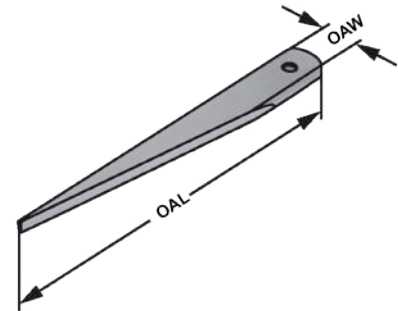

DIN
317

Bestell-Nr. Order no. Référence	MK MT CM	OAL	OAW
107.03.01	MK 1+2	140	20
107.03.03	MK 3	190	25
107.03.04	MK 4	225	30
107.03.05	MK 5+6	260	35

SPANNZANGEN
COLLETS
PINCES

SPANNZANGEN

COLLETS

PINCES

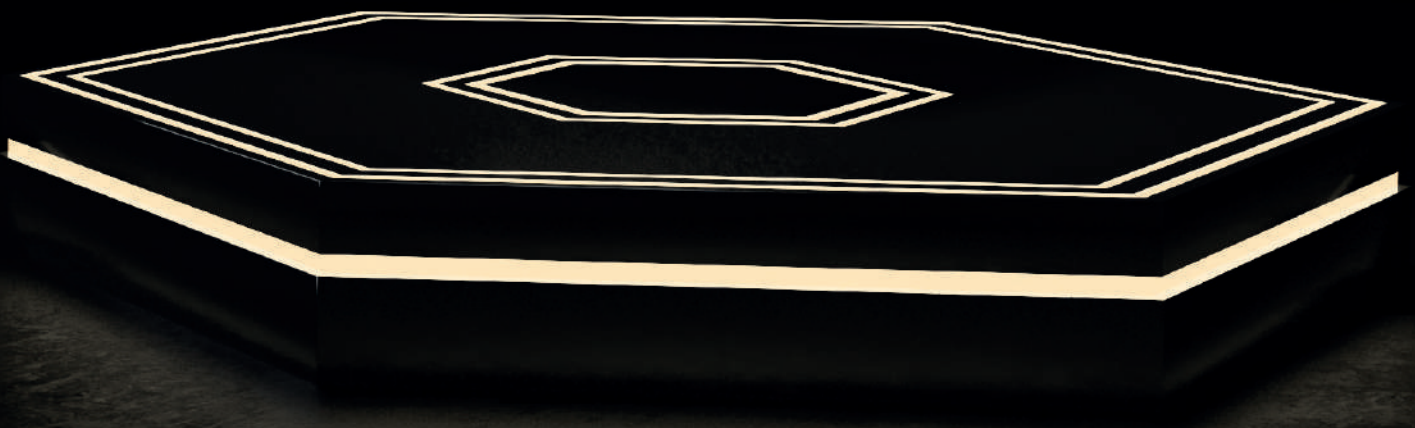
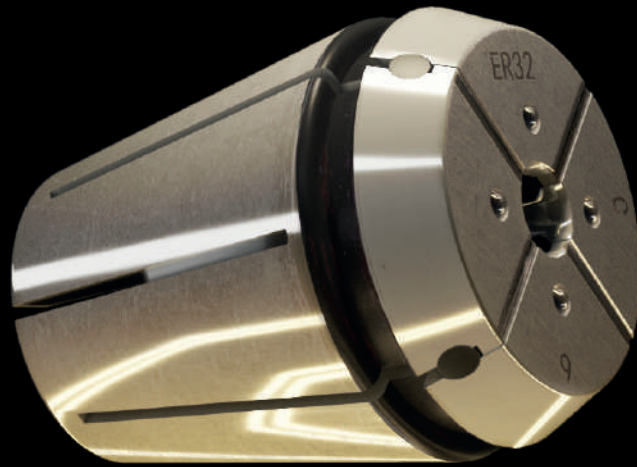

<p>9.05 9.06 415E 415EP OZ16</p> 	<p>9.07 9.08 462E 462EP OZ25</p> 	<p>9.09 9.10 467E 467EP OZ32</p> 	<p>9.11 4004EP ER8</p> 
<p>9.12 9.13 4008E ER11 4008EP</p> 	<p>9.14 4008ESP ER11</p> 	<p>9.15 9.16 426E ER16 426EP</p> 	<p>9.17 426EA ER16</p> 
<p>9.18 426EH ER16</p> 	<p>9.19 426EC ER16</p> 	<p>9.20 426ECC ER16</p> 	<p>9.21 426ESP ER16</p> 
<p>9.22 9.23 9.24 426G ER16 426GC 426GA</p> 	<p>9.25 9.26 428E ER20 428EP</p> 	<p>9.27 428EA ER20</p> 	<p>9.28 428EH ER20</p> 
<p>9.29 428EC ER20</p> 	<p>9.30 428ECC ER20</p> 	<p>9.31 428ESP ER20</p> 	<p>9.32 9.33 9.34 428G ER20 428GC 428GA</p> 
<p>9.35 9.36 430E ER25 430EP</p> 	<p>9.37 430EA ER25</p> 	<p>9.38 430EH ER25</p> 	<p>9.39 430EC ER25</p> 
<p>9.40 430ECC ER25</p> 	<p>9.41 430ESP ER25</p> 	<p>9.42 9.43 9.44 430G ER25 430GC 430GA</p> 	<p>9.46 9.47 470E ER32 470EP</p> 

Index
Sommaire

<p>9.48</p> <p>470EPP ER32</p> 	<p>9.49</p> <p>470EA ER32</p> 	<p>9.50</p> <p>470ECC ER32</p> 	<p>9.51</p> <p>470EH ER32</p> 
<p>9.52</p> <p>470EHP ER32</p> 	<p>9.53</p> <p>470EC ER32</p> 	<p>9.54</p> <p>470ECP ER32</p> 	<p>9.55</p> <p>470ESP ER32</p> 
<p>9.56 9.57 9.58</p> <p>470G ER32 470GC 470GA</p> 	<p>9.59 9.60</p> <p>472E ER40 472EP</p> 	<p>9.61</p> <p>472EA ER40</p> 	<p>9.62</p> <p>472EH ER40</p> 
<p>9.63</p> <p>472EC ER40</p> 	<p>9.64</p> <p>472ECC ER40</p> 	<p>9.65 9.66 9.67</p> <p>472G ER40 472GC 472GA</p> 	<p>9.68 - 9.78</p> 
<p>9.68 - 9.78</p> 	<p>9.79</p> 	<p>9.80</p> 	<p>9.81</p> <p>System KPS</p> 
<p>9.85</p> <p>System HKS</p> 	<p>9.87</p> <p>System HKS</p> 	<p>9.89</p> <p>System Hydro</p> 	<p>9.92</p> <p>System Hydro</p> 

Collets ISO 10897-B (DIN 6388 B) | OC system
 Pincés de serrage ISO 10897-B (DIN 6388 B) | Type OZ



Verwendung:
 Zur Aufnahme von Werkzeugen mit Zylinderschaft in Spannfutter DIN 6391. Für höchste radiale und axiale Belastungen.

Application:
 For mounting straight-shank tools in collet chucks DIN 6391. For highest axial and radial loading.

Application:
 Pour le serrage d'outils avec queue cylindrique dans mandrins à pincés DIN 6391. Pour une charge radiale et axiale maximale.

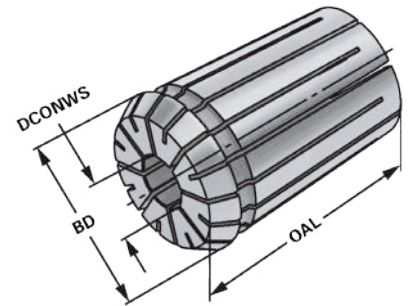

Bestell-Nr. Order no. Référence	Größe Size Taille	DCONWS	BD	OAL
415E-02	415E OZ 16	2 - 1,5	25,5	40
415E-03	415E OZ 16	3 - 2,5	25,5	40
415E-04	415E OZ 16	4 - 3,5	25,5	40
415E-05	415E OZ 16	5 - 4,5	25,5	40
415E-06	415E OZ 16	6 - 5,5	25,5	40
415E-07	415E OZ 16	7 - 6,5	25,5	40
415E-08	415E OZ 16	8 - 7,5	25,5	40
415E-09	415E OZ 16	9 - 8,5	25,5	40
415E-10	415E OZ 16	10 - 9,5	25,5	40
415E-11	415E OZ 16	11 - 10,5	25,5	40
415E-12	415E OZ 16	12 - 11,5	25,5	40
415E-13	415E OZ 16	13 - 12,5	25,5	40
415E-14	415E OZ 16	14 - 13,5	25,5	40
415E-15	415E OZ 16	15 - 14,5	25,5	40
415E-16	415E OZ 16	16 - 15,5	25,5	40



Precision collets ISO 10897-B (DIN 6388 B) | OC system

Pinces de serrage de précision ISO 10897-B (DIN 6388 B) | Type OZ



Verwendung:

Zur Aufnahme von Werkzeugen mit Zylinderschaft in Spannfutter DIN 6391. Für Anwendungen im HSC-Bereich und für hochpräzise Bearbeitungsergebnisse.

Application:

For mounting straight-shank tools in collet chucks DIN 6391. To use for high speed cutting and high precision milling.

Application:

Pour le serrage d'outils avec queue cylindrique dans mandrins à pinces DIN 6391. Pour l'usage dans le coupage à grande vitesse et dans l'usinage à grande précision.

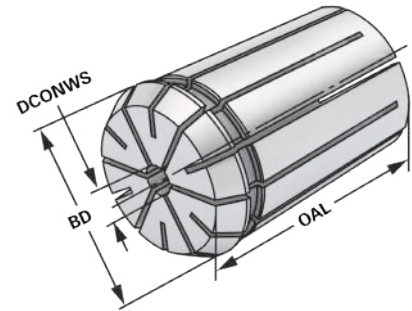

Bestell-Nr. Order no. Référence	Größe Size Taille	DCONWS	BD	OAL
415EP-02	415E OZ 16	2 – 1,5	25,5	40
415EP-03	415E OZ 16	3 – 2,5	25,5	40
415EP-04	415E OZ 16	4 – 3,5	25,5	40
415EP-05	415E OZ 16	5 – 4,5	25,5	40
415EP-06	415E OZ 16	6 – 5,5	25,5	40
415EP-07	415E OZ 16	7 – 6,5	25,5	40
415EP-08	415E OZ 16	8 – 7,5	25,5	40
415EP-09	415E OZ 16	9 – 8,5	25,5	40
415EP-10	415E OZ 16	10 – 9,5	25,5	40
415EP-11	415E OZ 16	11 – 10,5	25,5	40
415EP-12	415E OZ 16	12 – 11,5	25,5	40
415EP-13	415E OZ 16	13 – 12,5	25,5	40
415EP-14	415E OZ 16	14 – 13,5	25,5	40
415EP-15	415E OZ 16	15 – 14,5	25,5	40
415EP-16	415E OZ 16	16 – 15,5	25,5	40



Collets ISO 10897-B (DIN 6388 B) | OC system
 Pincés de serrage ISO 10897-B (DIN 6388 B) | Type OZ



Verwendung:
 Zur Aufnahme von Werkzeugen mit Zylinderschaft in Spannfutter DIN 6391. Für höchste radiale und axiale Belastungen.

Application:
 For mounting straight-shank tools in collet chucks DIN 6391. For highest axial and radial loading.

Application:
 Pour le serrage d'outils avec queue cylindrique dans mandrins à pincés DIN 6391. Pour une charge radiale et axiale maximale.

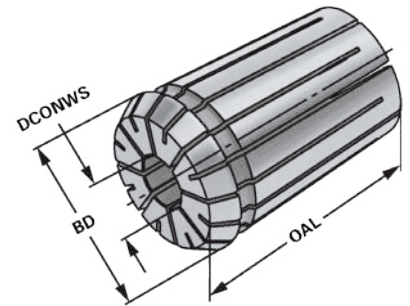

Bestell-Nr. Order no. Référence	Größe Size Taille	DCONWS	BD	OAL
462E-02	462E OZ 25	2 - 1,5	35,05	52
462E-03	462E OZ 25	3 - 2,5	35,05	52
462E-04	462E OZ 25	4 - 3,5	35,05	52
462E-05	462E OZ 25	5 - 4,5	35,05	52
462E-06	462E OZ 25	6 - 5,5	35,05	52
462E-07	462E OZ 25	7 - 6,5	35,05	52
462E-08	462E OZ 25	8 - 7,5	35,05	52
462E-09	462E OZ 25	9 - 8,5	35,05	52
462E-10	462E OZ 25	10 - 9,5	35,05	52
462E-11	462E OZ 25	11 - 10,5	35,05	52
462E-12	462E OZ 25	12 - 11,5	35,05	52
462E-13	462E OZ 25	13 - 12,5	35,05	52
462E-14	462E OZ 25	14 - 13,5	35,05	52
462E-15	462E OZ 25	15 - 14,5	35,05	52
462E-16	462E OZ 25	16 - 15,5	35,05	52
462E-17	462E OZ 25	17 - 16,5	35,05	52
462E-18	462E OZ 25	18 - 17,5	35,05	52
462E-19	462E OZ 25	19 - 18,5	35,05	52
462E-20	462E OZ 25	20 - 19,5	35,05	52
462E-21	462E OZ 25	21 - 20,5	35,05	52
462E-22	462E OZ 25	22 - 21,5	35,05	52
462E-23	462E OZ 25	23 - 22,5	35,05	52
462E-24	462E OZ 25	24 - 23,5	35,05	52
462E-25	462E OZ 25	25 - 24,5	35,05	52



Precision collets ISO 10897-B (DIN 6388 B) | OC system

Pinces de serrage de précision ISO 10897-B (DIN 6388 B) | Type OZ



Verwendung:

Zur Aufnahme von Werkzeugen mit Zylinderschaft in Spannfutter DIN 6391. Für Anwendungen im HSC-Bereich und für hochpräzise Bearbeitungsergebnisse.

Application:

For mounting straight-shank tools in collet chucks DIN 6391. To use for high speed cutting and high precision milling.

Application:

Pour le serrage d'outils avec queue cylindrique dans mandrins à pinces DIN 6391. Pour l'usage dans le coupage à grande vitesse et dans l'usinage à grande précision.

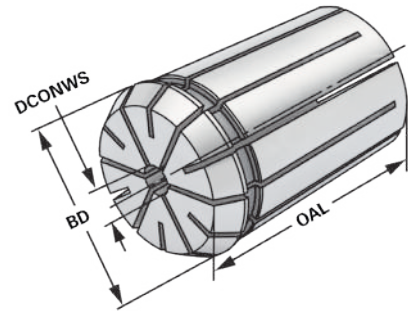

Bestell-Nr. Order no. Référence	Größe Size Taille	DCONWS	BD	OAL
462EP-02	462E OZ 25	2 – 1,5	35,05	52
462EP-03	462E OZ 25	3 – 2,5	35,05	52
462EP-04	462E OZ 25	4 – 3,5	35,05	52
462EP-05	462E OZ 25	5 – 4,5	35,05	52
462EP-06	462E OZ 25	6 – 5,5	35,05	52
462EP-07	462E OZ 25	7 – 6,5	35,05	52
462EP-08	462E OZ 25	8 – 7,5	35,05	52
462EP-09	462E OZ 25	9 – 8,5	35,05	52
462EP-10	462E OZ 25	10 – 9,5	35,05	52
462EP-11	462E OZ 25	11 – 10,5	35,05	52
462EP-12	462E OZ 25	12 – 11,5	35,05	52
462EP-13	462E OZ 25	13 – 12,5	35,05	52
462EP-14	462E OZ 25	14 – 13,5	35,05	52
462EP-15	462E OZ 25	15 – 14,5	35,05	52
462EP-16	462E OZ 25	16 – 15,5	35,05	52
462EP-17	462E OZ 25	17 – 16,5	35,05	52
462EP-18	462E OZ 25	18 – 17,5	35,05	52
462EP-19	462E OZ 25	19 – 18,5	35,05	52
462EP-20	462E OZ 25	20 – 19,5	35,05	52
462EP-21	462E OZ 25	21 – 20,5	35,05	52
462EP-22	462E OZ 25	22 – 21,5	35,05	52
462EP-23	462E OZ 25	23 – 22,5	35,05	52
462EP-24	462E OZ 25	24 – 23,5	35,05	52
462EP-25	462E OZ 25	25 – 24,5	35,05	52



Collets ISO 10897-B (DIN 6388 B) | OC system
 Pincés de serrage ISO 10897-B (DIN 6388 B) | Type OZ



Verwendung:
 Zur Aufnahme von Werkzeugen mit Zylinderschaft in Spannfutter DIN 6391. Für höchste radiale und axiale Belastungen.

Application:
 For mounting straight-shank tools in collet chucks DIN 6391. For highest axial and radial loading.

Application:
 Pour le serrage d'outils avec queue cylindrique dans mandrins à pincés DIN 6391. Pour une charge radiale et axiale maximale.

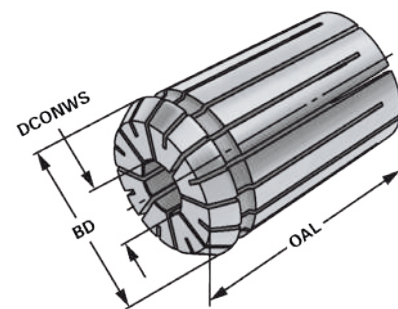

Bestell-Nr. Order no. Référence	Größe Size Taille	DCONWS	BD	OAL
467E-03	467E OZ 32	3 - 2,5	43,7	60
467E-04	467E OZ 32	4 - 3,5	43,7	60
467E-05	467E OZ 32	5 - 4,5	43,7	60
467E-06	467E OZ 32	6 - 5,5	43,7	60
467E-07	467E OZ 32	7 - 6,5	43,7	60
467E-08	467E OZ 32	8 - 7,5	43,7	60
467E-09	467E OZ 32	9 - 8,5	43,7	60
467E-10	467E OZ 32	10 - 9,5	43,7	60
467E-11	467E OZ 32	11 - 10,5	43,7	60
467E-12	467E OZ 32	12 - 11,5	43,7	60
467E-13	467E OZ 32	13 - 12,5	43,7	60
467E-14	467E OZ 32	14 - 13,5	43,7	60
467E-15	467E OZ 32	15 - 14,5	43,7	60
467E-16	467E OZ 32	16 - 15,5	43,7	60
467E-17	467E OZ 32	17 - 16,5	43,7	60
467E-18	467E OZ 32	18 - 17,5	43,7	60
467E-19	467E OZ 32	19 - 18,5	43,7	60
467E-20	467E OZ 32	20 - 19,5	43,7	60
467E-21	467E OZ 32	21 - 20,5	43,7	60
467E-22	467E OZ 32	22 - 21,5	43,7	60
467E-23	467E OZ 32	23 - 22,5	43,7	60
467E-24	467E OZ 32	24 - 23,5	43,7	60
467E-25	467E OZ 32	25 - 24,5	43,7	60
467E-26	467E OZ 32	26 - 25,5	43,7	60
467E-27	467E OZ 32	27 - 26,5	43,7	60
467E-28	467E OZ 32	28 - 27,5	43,7	60
467E-29	467E OZ 32	29 - 28,5	43,7	60
467E-30	467E OZ 32	30 - 29,5	43,7	60
467E-31	467E OZ 32	31 - 30,5	43,7	60
467E-32	467E OZ 32	32 - 31,5	43,7	60



Precision collets ISO 10897-B (DIN 6388 B) | OC system

Pinces de serrage de précision ISO 10897-B (DIN 6388 B) | Type OZ



Verwendung:

Zur Aufnahme von Werkzeugen mit Zylinderschaft in Spannfutter DIN 6391. Für Anwendungen im HSC-Bereich und für hochpräzise Bearbeitungsergebnisse.

Application:

For mounting straight-shank tools in collet chucks DIN 6391. To use for high speed cutting and high precision milling.

Application:

Pour le serrage d'outils avec queue cylindrique dans mandrins à pinces DIN 6391. Pour l'usage dans le coupage à grande vitesse et dans l'usinage à grande précision.

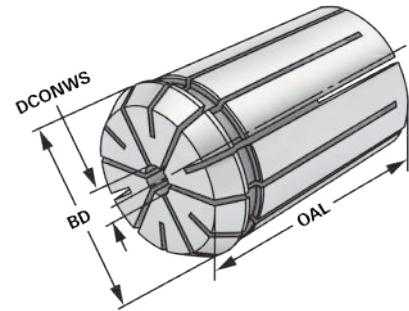

Bestell-Nr. Order no. Référence	Größe Size Taille	DCONWS	BD	OAL
467EP-03	467E OZ 32	3 – 2,5	43,7	60
467EP-04	467E OZ 32	4 – 3,5	43,7	60
467EP-05	467E OZ 32	5 – 4,5	43,7	60
467EP-06	467E OZ 32	6 – 5,5	43,7	60
467EP-07	467E OZ 32	7 – 6,5	43,7	60
467EP-08	467E OZ 32	8 – 7,5	43,7	60
467EP-09	467E OZ 32	9 – 8,5	43,7	60
467EP-10	467E OZ 32	10 – 9,5	43,7	60
467EP-11	467E OZ 32	11 – 10,5	43,7	60
467EP-12	467E OZ 32	12 – 11,5	43,7	60
467EP-13	467E OZ 32	13 – 12,5	43,7	60
467EP-14	467E OZ 32	14 – 13,5	43,7	60
467EP-15	467E OZ 32	15 – 14,5	43,7	60
467EP-16	467E OZ 32	16 – 15,5	43,7	60
467EP-17	467E OZ 32	17 – 16,5	43,7	60
467EP-18	467E OZ 32	18 – 17,5	43,7	60
467EP-19	467E OZ 32	19 – 18,5	43,7	60
467EP-20	467E OZ 32	20 – 19,5	43,7	60
467EP-21	467E OZ 32	21 – 20,5	43,7	60
467EP-22	467E OZ 32	22 – 21,5	43,7	60
467EP-23	467E OZ 32	23 – 22,5	43,7	60
467EP-24	467E OZ 32	24 – 23,5	43,7	60
467EP-25	467E OZ 32	25 – 24,5	43,7	60
467EP-26	467E OZ 32	26 – 25,5	43,7	60
467EP-27	467E OZ 32	27 – 26,5	43,7	60
467EP-28	467E OZ 32	28 – 27,5	43,7	60
467EP-29	467E OZ 32	29 – 28,5	43,7	60
467EP-30	467E OZ 32	30 – 29,5	43,7	60
467EP-31	467E OZ 32	31 – 30,5	43,7	60
467EP-32	467E OZ 32	32 – 31,5	43,7	60



Precision collets ISO 15488 B (DIN 6499 B) | ER system

Pinces de serrage de précision ISO 15488 B (DIN 6499 B) | Type ER



Verwendung:

Zur Aufnahme von Werkzeugen mit Zylinderschaft in Spannfutter DIN 6499.

Application:

For mounting straight-shank tools in collet chucks DIN 6499.

Application:

Pour le serrage d'outils avec queue cylindrique dans mandrins à pinces DIN 6499.

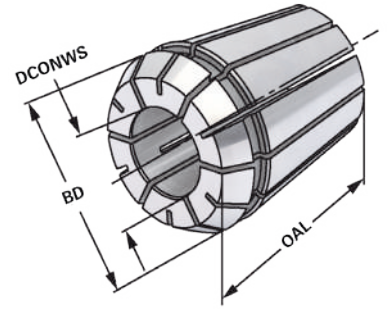

Bestell-Nr. Order no. Référence	Größe Size Taille	DCONWS	BD	OAL
4004EP-01	4004E ER 8	1,0 - 0,5	8,5	13,5
4004EP-015	4004E ER 8	1,5 - 1,0	8,5	13,5
4004EP-02	4004E ER 8	2,0 - 1,5	8,5	13,5
4004EP-025	4004E ER 8	2,5 - 2,0	8,5	13,5
4004EP-03	4004E ER 8	3,0 - 2,5	8,5	13,5
4004EP-035	4004E ER 8	3,5 - 3,0	8,5	13,5
4004EP-04	4004E ER 8	4,0 - 3,5	8,5	13,5
4004EP-045	4004E ER 8	4,5 - 4,0	8,5	13,5
4004EP-05	4004E ER 8	5,0 - 4,5	8,5	13,5

Hinweis: Spannbereich bis -0,5 mm
Note: Clamping capacity up to -0,5 mm
Observation: Serrage jusqu'à -0,5 mm



9.70



10.10

Collets ISO 15488 B (DIN 6499 B) | ER system
 Pincés de serrage ISO 15488 B (DIN 6499 B) | Type ER



Verwendung:
 Zur Aufnahme von Werkzeugen mit Zylinderschaft in Spannfutter DIN 6499.

Application:
 For mounting straight-shank tools in collet chucks DIN 6499.

Application:
 Pour le serrage d'outils avec queue cylindrique dans mandrins à pincés DIN 6499.

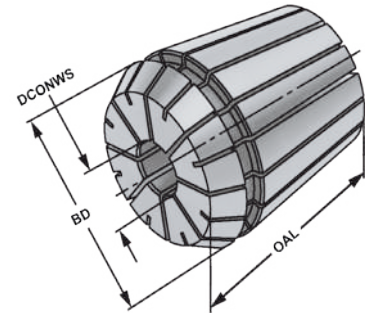

ISO
15488

ER

$\leq 15\mu\text{m}$

13.04

Bestell-Nr. Order no. Référence	Größe Size Taille	DCONWS	BD	OAL
4008E-01	4008E ER 11	1,0 - 0,5	11,5	18
4008E-015	4008E ER 11	1,5 - 1,0	11,5	18
4008E-02	4008E ER 11	2,0 - 1,5	11,5	18
4008E-025	4008E ER 11	2,5 - 2,0	11,5	18
4008E-03	4008E ER 11	3,0 - 2,5	11,5	18
4008E-035	4008E ER 11	3,5 - 3,0	11,5	18
4008E-04	4008E ER 11	4,0 - 3,5	11,5	18
4008E-045	4008E ER 11	4,5 - 4,0	11,5	18
4008E-05	4008E ER 11	5,0 - 4,5	11,5	18
4008E-055	4008E ER 11	5,5 - 5,0	11,5	18
4008E-06	4008E ER 11	6,0 - 5,5	11,5	18
4008E-065	4008E ER 11	6,5 - 6,0	11,5	18
4008E-07	4008E ER 11	7,0 - 6,5	11,5	18

Hinweis: Spannbereich bis -0,5 mm
Note: Clamping capacity up to -0,5 mm
Observation: Serrage jusqu'à -0,5 mm



Precision collets ISO 15488 B (DIN 6499 B) | ER system

Pinces de serrage de précision ISO 15488 B (DIN 6499 B) | Type ER



Verwendung:

Zur Aufnahme von Werkzeugen mit Zylinderschaft in Spannfutter DIN 6499. Für Anwendungen im HSC-Bereich und für hochpräzise Bearbeitungsergebnisse.

Application:

For mounting straight-shank tools in collet chucks DIN 6499. To use for high speed cutting and high precision milling.

Application:

Pour le serrage d'outils avec queue cylindrique dans mandrins à pinces DIN 6499. Pour l'usage dans le coupage à grande vitesse et dans l'usinage à grande précision.

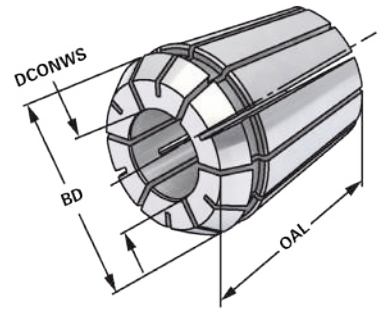

Bestell-Nr. Order no. Référence	Größe Size Taille	DCONWS	BD	OAL
4008EP-01	4008E ER 11	1,0 - 0,5	11,5	18
4008EP-015	4008E ER 11	1,5 - 1,0	11,5	18
4008EP-02	4008E ER 11	2,0 - 1,5	11,5	18
4008EP-025	4008E ER 11	2,5 - 2,0	11,5	18
4008EP-03	4008E ER 11	3,0 - 2,5	11,5	18
4008EP-035	4008E ER 11	3,5 - 3,0	11,5	18
4008EP-04	4008E ER 11	4,0 - 3,5	11,5	18
4008EP-045	4008E ER 11	4,5 - 4,0	11,5	18
4008EP-05	4008E ER 11	5,0 - 4,5	11,5	18
4008EP-055	4008E ER 11	5,5 - 5,0	11,5	18
4008EP-06	4008E ER 11	6,0 - 5,5	11,5	18
4008EP-065	4008E ER 11	6,5 - 6,0	11,5	18
4008EP-07	4008E ER 11	7,0 - 6,5	11,5	18

Hinweis: Spannbereich bis -0,5 mm
Note: Clamping capacity up to -0,5 mm
Observation: Serrage jusqu'à -0,5 mm



9.70



9.70



10.09

Precision collets ISO 15488 B (DIN 6499 B) | ER system - stainless steel

Pinces de serrage de précision ISO 15488 B (DIN 6499 B) | Type ER - acier inoxydable



Verwendung:

Zur Aufnahme von Werkzeugen mit Zylinderschaft in Spannfutter DIN 6499. Für Anwendungen im HSC-Bereich und für hochpräzise Bearbeitungsergebnisse.

Application:

For mounting straight-shank tools in collet chucks DIN 6499. To use for high speed cutting and high precision milling.

Application:

Pour le serrage d'outils avec queue cylindrique dans mandrins à pinces DIN 6499. Pour l'usage dans le coupage à grande vitesse et dans l'usinage à grande précision.

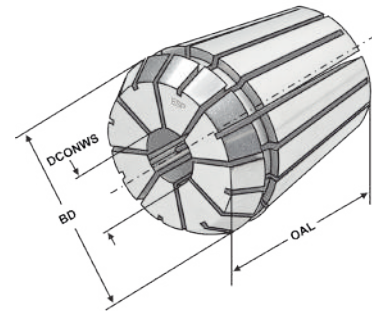

ISO 15488 ER $\leq 5\mu\text{m}$ Inox

13.04

Bestell-Nr. Order no. Référence	Größe Size Taille	DCONWS	BD	OAL
4008ESP-03	4008E ER 11	3,0 - 2,5	11,5	18
4008ESP-035	4008E ER 11	3,5 - 3,0	11,5	18
4008ESP-04	4008E ER 11	4,0 - 3,5	11,5	18
4008ESP-045	4008E ER 11	4,5 - 4,0	11,5	18
4008ESP-05	4008E ER 11	5,0 - 4,5	11,5	18
4008ESP-055	4008E ER 11	5,5 - 5,0	11,5	18
4008ESP-06	4008E ER 11	6,0 - 5,5	11,5	18
4008ESP-065	4008E ER 11	6,5 - 6,0	11,5	18
4008ESP-07	4008E ER 11	7,0 - 6,5	11,5	18

Hinweis: Spannbereich bis -0,5 mm
Note: Clamping capacity up to -0,5 mm
Observation: Serrage jusqu'à -0,5 mm

- Rostfrei
- Edelstahl 1.4021 x 20Cr13
- Höhere Wiederholgenauigkeit
- Spannzangenbohrung gehont
- Besonders geeignet für Drahterosion

- Rustproof
- Stainless steel 1.4021 x 20Cr13
- Higher repeat-accuracy
- Honed collet boring
- Especially suitable fore wire EDM

- Inoxydable
- Acier affiné 1.4021 x 20Cr13
- Répétabilité supérieure
- Alésage de pince aiguisé
- Convient particulièrement pour le fil EDM



Collets ISO 15488 B (DIN 6499 B) | ER system
 Pincés de serrage ISO 15488 B (DIN 6499 B) | Type ER



Verwendung:
 Zur Aufnahme von Werkzeugen mit Zylinderschaft in Spannfutter DIN 6499.

Application:
 For mounting straight-shank tools in collet chucks DIN 6499.

Application:
 Pour le serrage d'outils avec queue cylindrique dans mandrins à pincés DIN 6499.

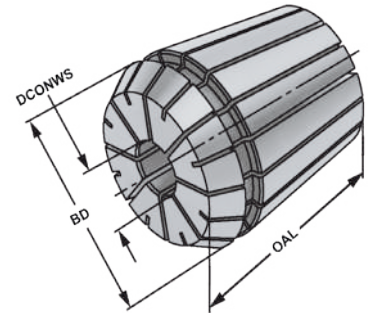

ISO 15488

ER

$\leq 15\mu\text{m}$

13.04

Bestell-Nr. Order no. Référence	Größe Size Taille	DCONWS	BD	OAL
426E-01	426E ER 16	1 - 0,5	17	27
426E-02	426E ER 16	2 - 1,0	17	27
426E-03	426E ER 16	3 - 2,0	17	27
426E-04	426E ER 16	4 - 3,0	17	27
426E-05	426E ER 16	5 - 4,0	17	27
426E-06	426E ER 16	6 - 5,0	17	27
426E-07	426E ER 16	7 - 6,0	17	27
426E-08	426E ER 16	8 - 7,0	17	27
426E-09	426E ER 16	9 - 8,0	17	27
426E-10	426E ER 16	10 - 9,0	17	27

Hinweis: Hohe Flexibilität: Großer Spannbereich bis -1 mm
Note: High flexibility: Large holding capacity up to -1 mm
Observation: Grande capacité de serrage jusqu'à -1 mm



Precision collets ISO 15488 B (DIN 6499 B) | ER system

Pinces de serrage de précision ISO 15488 B (DIN 6499 B) | Type ER



Verwendung:

Zur Aufnahme von Werkzeugen mit Zylinderschaft in Spannfutter DIN 6499. Für Anwendungen im HSC-Bereich und für hochpräzise Bearbeitungsergebnisse.

Application:

For mounting straight-shank tools in collet chucks DIN 6499. To use for high speed cutting and high precision milling.

Application:

Pour le serrage d'outils avec queue cylindrique dans mandrins à pinces DIN 6499. Pour l'usage dans le coupage à grande vitesse et dans l'usinage à grande précision.

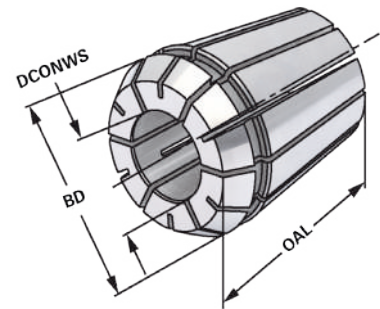

Bestell-Nr. Order no. Référence	Größe Size Taille	DCONWS	BD	OAL
426EP-01	426E ER 16	1 - 0,5	17	27
426EP-02	426E ER 16	2 - 1,0	17	27
426EP-03	426E ER 16	3 - 2,0	17	27
426EP-04	426E ER 16	4 - 3,0	17	27
426EP-05	426E ER 16	5 - 4,0	17	27
426EP-06	426E ER 16	6 - 5,0	17	27
426EP-07	426E ER 16	7 - 6,0	17	27
426EP-08	426E ER 16	8 - 7,0	17	27
426EP-09	426E ER 16	9 - 8,0	17	27
426EP-10	426E ER 16	10 - 9,0	17	27

Hinweis: Hohe Flexibilität: Großer Spannbereich bis -1 mm
Note: High flexibility: Large holding capacity up to -1 mm
Observation: Grande capacité de serrage jusqu'à -1 mm





Collets sealed for IC - ISO 15488 B (DIN 6499 B) | ER system

Pinces de serrage avec joint d'étanchéité pour IC - ISO 15488 B (DIN 6499 B) | Type ER



Verwendung:

Zur Aufnahme von Werkzeugen mit Innenkühlung und Zylinderschaft in Spannfutter DIN 6499

Application:

For mounting straight-shank tools with internal cooling in collet chucks DIN 6499

Application:

Pour le serrage des outils avec le refroidissement interne et avec queue cylindrique dans mandrins à pinces DIN 6499

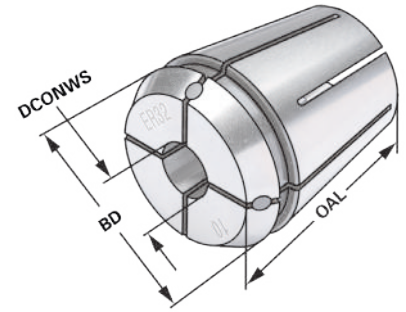

Bestell-Nr. Order no. Référence	Größe Size Taille	DCONWS	BD	OAL
426EA-03	426E ER 16	3	17	27
426EA-04	426E ER 16	4	17	27
426EA-05	426E ER 16	5	17	27
426EA-06	426E ER 16	6	17	27
426EA-07	426E ER 16	7	17	27
426EA-08	426E ER 16	8	17	27
426EA-09	426E ER 16	9	17	27
426EA-10	426E ER 16	10	17	27

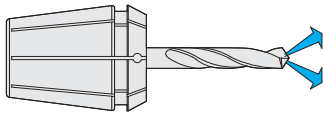

9

Hinweis:

Nur das Nennmaß DCONWS kann gespannt werden, mit Dichtstopfen für Innenkühlung (einsetzbar bis 21 bar). Um eine optimale Abdichtung zu erreichen, muss das zu spannende Werkzeug auf der ganzen Länge der geschliffenen Bohrung der Spannzange eingespannt werden.

Note:

Only nominal size DCONWS can be clamped with sealing plug for internal cooling (applicable up to 21 bar). In order to achieve an optimum sealing the tool must be clamped on the complete length of the ground drill of the collet.

Observation:

Seulement la dimension nominale DCONWS peut être tendu avec des bochons 'étan héité pour le refroidissement interne (peut être utilisé jusqu'à 21 bar). Afin d'obtenir un étanchéité optimal l'outil doit être serré sur la lon gueur complète de l'alésage rectifié de la pince.



Collets steel sealed for high pressure cooling up to 120 bar | ER system

Pinces de serrage, étanche pour arrosage de haute pression 120 bar | Type ER



Verwendung:

Zur Aufnahme von Werkzeugen mit Innenkühlung und Zylinderschaft in Spannfutter DIN 6499

Application:

For mounting straight-shank tools with internal cooling in collet chucks DIN 6499

Application:

Pour le serrage des outils avec le refroidissement interne et avec queue cylindrique dans mandrins à pinces DIN 6499

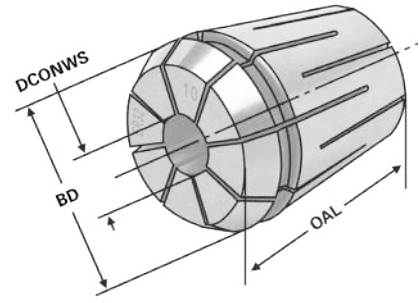

Bestell-Nr. Order no. Référence	Größe Size Taille	DCONWS	BD	OAL
426EH-03	426E ER 16	3	17	27
426EH-04	426E ER 16	4	17	27
426EH-05	426E ER 16	5	17	27
426EH-06	426E ER 16	6	17	27
426EH-07	426E ER 16	7	17	27
426EH-08	426E ER 16	8	17	27
426EH-09	426E ER 16	9	17	27
426EH-10	426E ER 16	10	17	27

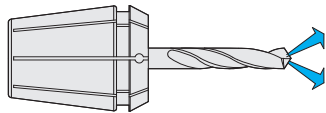

Hinweis:

Nur das Nennmaß DCONWS kann gespannt werden (einsetzbar bis 120 bar). Um eine optimale Abdichtung zu erreichen, muss das zu spannende Werkzeug auf der ganzen Länge der geschliffenen Bohrung der Spannzange eingespannt werden.

Note:

Only nominal size DCONWS can be clamped (applicable up to 120 bar). In order to achieve an optimum sealing the tool must be clamped on the complete length of the ground drill of the collet.

Observation:

Seulement la dimension nominale DCONWS peut être tendu (peut être utilisé jusqu'à 120 bar). Afin d'obtenir un étanchéité optimal l'outil doit être serré sur la longueur complète de l'alésage rectifié de la pince.



Collets with cooling channels ISO 15488 B (DIN 6499 B) | ER system
 Pincettes de serrage avec canaux d'arrosage ISO 15488 B (DIN 6499 B) | Type ER



Verwendung:
 Zur Aufnahme von Werkzeugen mit Zylinderschaft in Spannfutter DIN 6499.

Application:
 For mounting straight-shank tools in collet chucks DIN 6499.

Application:
 Pour le serrage d'outils avec queue cylindrique dans mandrins à pincettes DIN 6499.

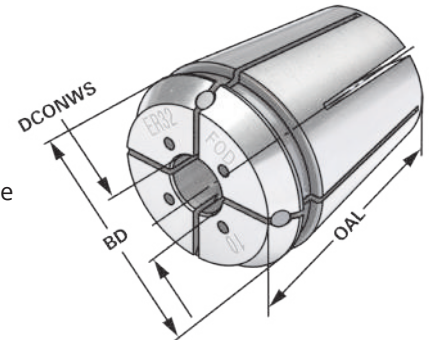

Bestell-Nr. Order no. Référence	Größe Size Taille	DCONWS	BD	OAL
426EC-03	426E ER 16	3	17	27
426EC-04	426E ER 16	4	17	27
426EC-05	426E ER 16	5	17	27
426EC-06	426E ER 16	6	17	27
426EC-07	426E ER 16	7	17	27



Hinweis: Nur das Nennmaß DCONWS kann gespannt werden, mit Kühlkanälen. Einsetzbar bis 21 bar. Um eine optimale Abdichtung zu erreichen, muss das zu spannende Werkzeug auf der ganzen Länge der geschliffenen Bohrung der Spannzange eingespannt werden.

Note: Only nominal size DCONWS can be clamped, with cooling channels. Applicable up to 21 bar. In order to achieve an optimum sealing the tool must be clamped on the complete length of the ground drill of the collet.

Observation: Seulement la dimension nominale DCONWS peut être tendu, avec canaux d'arrosage. Peut être utilisé jusqu'à 21 bar. Afin d'obtenir un étanchéité optimal l'outil doit être serré sur la longueur complète de l'alésage rectifié de la pince.

9



ISO 15488 B (DIN 6499 B) | ER System

Collets with cooling channels along the boring ISO 15488 B (DIN 6499 B) | ER system
 Pincés de serrage avec canaux d'arrosage le long de l'alésage ISO 15488 B (DIN 6499 B) | Type ER



Verwendung:
 Zur Aufnahme von Werkzeugen mit Zylinderschaft in Spannfutter DIN 6499.

Application:
 For mounting straight-shank tools in collet chucks DIN 6499.

Application:
 Pour le serrage d'outils avec queue cylindrique dans mandrins à pincés DIN 6499.

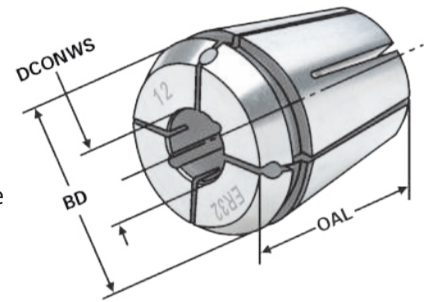

Bestell-Nr. Order no. Référence	Größe Size Taille	DCONWS	BD	OAL
426ECC-03	426E ER 16	3	17	27
426ECC-04	426E ER 16	4	17	27
426ECC-05	426E ER 16	5	17	27
426ECC-06	426E ER 16	6	17	27
426ECC-07	426E ER 16	7	17	27



- Hinweis:** Nur das Nennmaß DCONWS kann gespannt werden, mit Kühlkanälen entlang der Bohrung. Einsetzbar bis 21 bar. Um eine optimale Abdichtung zu erreichen, muss das zu spannende Werkzeug auf der ganzen Länge der geschliffenen Bohrung der Spannzange eingespannt werden.
- Note:** Only nominal size DCONWS can be clamped, with cooling channels along the boring. Applicable up to 21 bar. In order to achieve an optimum sealing the tool must be clamped on the complete length of the ground drill of the collet.
- Observation:** Seulement la dimension nominale DCONWS peut être tendu, avec canaux d'arrosage le long de l'alésage. Peut être utilisé jusqu'à 21 bar. Afin d'obtenir un étanchéité optimal l'outil doit être serré sur la longueur complète de l'alésage rectifié de la pince.

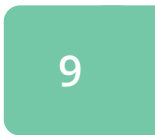

Precision collets ISO 15488 B (DIN 6499 B) | ER system - stainless steel

Pinces de serrage de précision ISO 15488 B (DIN 6499 B) | Type ER - acier inoxydable



Verwendung:

Zur Aufnahme von Werkzeugen mit Zylinderschaft in Spannfutter DIN 6499. Für Anwendungen im HSC-Bereich und für hochpräzise Bearbeitungsergebnisse.

Application:

For mounting straight-shank tools in collet chucks DIN 6499. To use for high speed cutting and high precision milling.

Application:

Pour le serrage d'outils avec queue cylindrique dans mandrins à pinces DIN 6499. Pour l'usage dans le coupe à grande vitesse et dans l'usinage à grande précision.

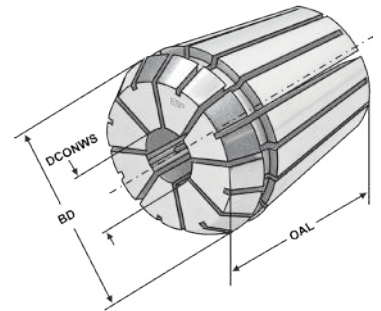

ISO 15488 ER $\leq 5\mu\text{m}$ Inox



Bestell-Nr. Order no. Référence	Größe Size Taille	DCONWS	BD	OAL
426ESP-03	426E ER 16	3 - 2,5	17	27
426ESP-035	426E ER 16	3,5 - 3,0	17	27
426ESP-04	426E ER 16	4 - 3,5	17	27
426ESP-045	426E ER 16	4,5 - 4,0	17	27
426ESP-05	426E ER 16	5 - 4,5	17	27
426ESP-055	426E ER 16	5,5 - 5,0	17	27
426ESP-06	426E ER 16	6 - 5,5	17	27
426ESP-065	426E ER 16	6,5 - 6,0	17	27
426ESP-07	426E ER 16	7 - 6,5	17	27
426ESP-075	426E ER 16	7,5 - 7,0	17	27
426ESP-08	426E ER 16	8 - 7,5	17	27
426ESP-085	426E ER 16	8,5 - 8,0	17	27
426ESP-09	426E ER 16	9 - 8,5	17	27
426ESP-095	426E ER 16	9,5 - 9,0	17	27
426ESP-10	426E ER 16	10 - 9,5	17	27

9

Hinweis: Spannbereich bis -0,5 mm
Note: Clamping capacity up to -0,5 mm
Observation: Serrage jusqu'à -0,5 mm

- Rostfrei
- Edelstahl 1.4021 x 20Cr13
- Höhere Wiederholgenauigkeit
- Spannzangenbohrung gehont
- Besonders geeignet für Drahterosion

- Rustproof
- Stainless steel 1.4021 x 20Cr13
- Higher repeat-accuracy
- Honed collet boring
- Especially suitable fore wire EDM

- Inoxydable
- Acier affiné 1.4021 x 20Cr13
- Répétabilité supérieure
- Alésage de pince aiguisé
- Convient particulièrement pour le fil EDM



Tap collets - ISO 15488 B (DIN 6499 B) | ER system

Pinces de serrage pour tarauds - ISO 15488 B (DIN 6499 B) | Type ER



Verwendung:

Für Maschinen mit steigungssynchronem Vorschub. Zur verdrehsicheren Spannung von Gewindebohrern.

Application:

For machines with rigid tapping. For safe clamping of taps.

Application:

Pour machines avec broche synchronisée. Pour le serrage stable de tarauds.

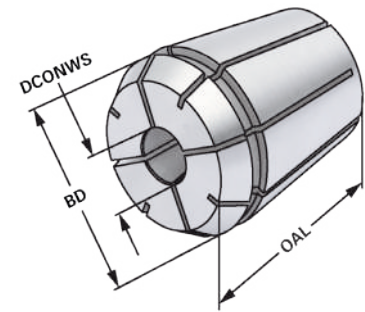

Bestell-Nr. Order no. Référence	Größe Size Taille	DCONWS	DRVS	BD	OAL
426G-3527	426E ER 16	3,5	2,7	16,8	27,5
426G-43	426E ER 16	4	3	16,8	27,5
426G-4534	426E ER 16	4,5	3,4	16,8	27,5
426G-649	426E ER 16	6	4,9	16,8	27,5
426G-755	426E ER 16	7	5,5	16,8	27,5
426G-862	426E ER 16	8	6,2	16,8	27,5



K Gewindebohrer Spannzangen mit Kühkanalbohrungen | ER System

Tap collets with cooling channels | ER system
Pinces de serrage avec canaux d'arrosage | Type ER

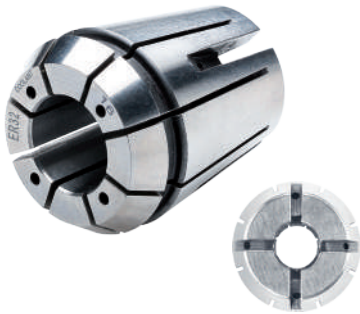

Verwendung:
Für Maschinen mit steigungssynchronem Vorschub. Zur verdrehsicheren Spannung von Gewindebohrern.

Application:
For machines with rigid tapping.
For safe clamping of taps.

Application:
Pour machines avec broche synchronisée.
Pour le serrage stable de tarauds.

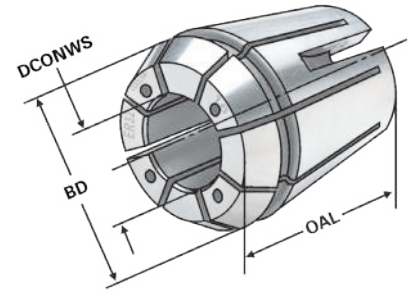

Bestell-Nr. Order no. Référence	Größe Size Taille	DCONWS	DRVS	BD	OAL
426GC-3527	426E ER 16	3,5	2,7	16,8	27,5
426GC-43	426E ER 16	4	3	16,8	27,5
426GC-4534	426E ER 16	4,5	3,4	16,8	27,5
426GC-649	426E ER 16	6	4,9	16,8	27,5
426GC-755	426E ER 16	7	5,5	16,8	27,5
426GC-862	426E ER 16	8	6,2	16,8	27,5



Tap collets with seals | ER system
Pincés de serrage pour tarauds | Type ER



Verwendung:
Für Maschinen mit steigungssynchronem Vorschub. Zur verdrehsicheren Spannung von Gewindebohrern.

Application:
For machines with rigid tapping.
For safe clamping of taps.

Application:
Pour machines avec broche synchronisée.
Pour le serrage stable de tarauds.

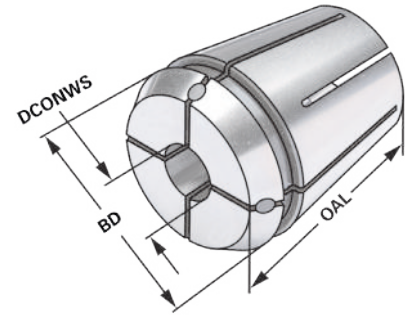

Bestell-Nr. Order no. Référence	Größe Size Taille	DCONWS	DRVS	BD	OAL
426GA-3527	426E ER 16	3,5	2,7	16,8	27,5
426GA-43	426E ER 16	4	3	16,8	27,5
426GA-4534	426E ER 16	4,5	3,4	16,8	27,5
426GA-649	426E ER 16	6	4,9	16,8	27,5
426GA-755	426E ER 16	7	5,5	16,8	27,5
426GA-862	426E ER 16	8	6,2	16,8	27,5

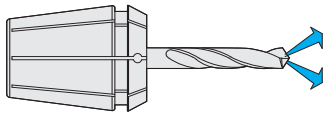

Collets ISO 15488 B (DIN 6499 B) | ER system
 Pincés de serrage ISO 15488 B (DIN 6499 B) | Type ER

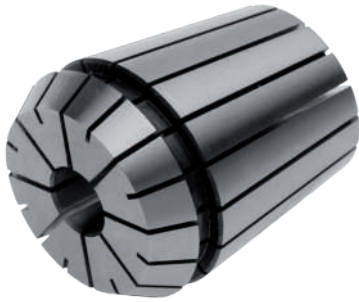

Verwendung:
 Zur Aufnahme von Werkzeugen mit Zylinderschaft in Spannfutter DIN 6499.

Application:
 For mounting straight-shank tools in collet chucks DIN 6499.

Application:
 Pour le serrage d'outils avec queue cylindrique dans mandrins à pincés DIN 6499.

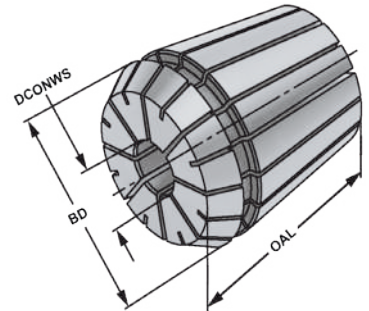

ISO
15488

ER

 ≤ 15µm

 13.04

Bestell-Nr. Order no. Référence	Größe Size Taille	DCONWS	BD	OAL
428E-02	428E ER 20	2 – 1,5	21	31,5
428E-03	428E ER 20	3 – 2,0	21	31,5
428E-04	428E ER 20	4 – 3,0	21	31,5
428E-05	428E ER 20	5 – 4,0	21	31,5
428E-06	428E ER 20	6 – 5,0	21	31,5
428E-07	428E ER 20	7 – 6,0	21	31,5
428E-08	428E ER 20	8 – 7,0	21	31,5
428E-09	428E ER 20	9 – 8,0	21	31,5
428E-10	428E ER 20	10 – 9,0	21	31,5
428E-11	428E ER 20	11 – 10,0	21	31,5
428E-12	428E ER 20	12 – 11,0	21	31,5
428E-13	428E ER 20	13 – 12,0	21	31,5

Hinweis: Hohe Flexibilität: Großer Spannbereich bis -1 mm
Note: High flexibility: Large holding capacity up to -1 mm
Observation: Grande capacité de serrage jusqu'à -1 mm



Precision collets ISO 15488 B (DIN 6499 B) | ER system

Pinces de serrage de précision ISO 15488 B (DIN 6499 B) | Type ER



Verwendung:

Zur Aufnahme von Werkzeugen mit Zylinderschaft in Spannfutter DIN 6499. Für Anwendungen im HSC-Bereich und für hochpräzise Bearbeitungsergebnisse.

Application:

For mounting straight-shank tools in collet chucks DIN 6499. To use for high speed cutting and high precision milling.

Application:

Pour le serrage d'outils avec queue cylindrique dans mandrins à pinces DIN 6499. Pour l'usage dans le coupage à grande vitesse et dans l'usinage à grande précision.

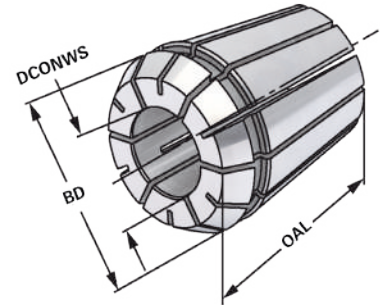

Bestell-Nr. Order no. Référence	Größe Size Taille	DCONWS	BD	OAL
428EP-02	428E ER 20	2 - 1,5	21	31,5
428EP-03	428E ER 20	3 - 2,0	21	31,5
428EP-04	428E ER 20	4 - 3,0	21	31,5
428EP-05	428E ER 20	5 - 4,0	21	31,5
428EP-06	428E ER 20	6 - 5,0	21	31,5
428EP-07	428E ER 20	7 - 6,0	21	31,5
428EP-08	428E ER 20	8 - 7,0	21	31,5
428EP-09	428E ER 20	9 - 8,0	21	31,5
428EP-10	428E ER 20	10 - 9,0	21	31,5
428EP-11	428E ER 20	11 - 10,0	21	31,5
428EP-12	428E ER 20	12 - 11,0	21	31,5
428EP-13	428E ER 20	13 - 12,0	21	31,5

Hinweis: Hohe Flexibilität: Großer Spannbereich bis -1 mm
Note: High flexibility: Large holding capacity up to -1 mm
Observation: Grande capacité de serrage jusqu'à -1 mm





Collets sealed for IC - ISO 15488 B (DIN 6499 B) | ER system

Pinces de serrage avec joint d'étanchéité pour IC - ISO 15488 B (DIN 6499 B) | Type ER



Verwendung:

Zur Aufnahme von Werkzeugen mit Innenkühlung und Zylinderschaft in Spannfutter DIN 6499

Application:

For mounting straight-shank tools with internal cooling in collet chucks DIN 6499

Application:

Pour le serrage des outils avec le refroidissement interne et avec queue cylindrique dans mandrins à pinces DIN 6499

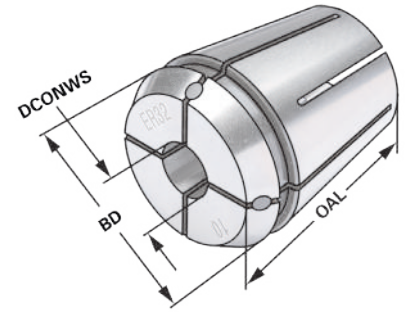

Bestell-Nr. Order no. Référence	Größe Size Taille	DCONWS	BD	OAL
428EA-03	428E ER 20	3	21	31,5
428EA-04	428E ER 20	4	21	31,5
428EA-05	428E ER 20	5	21	31,5
428EA-06	428E ER 20	6	21	31,5
428EA-07	428E ER 20	7	21	31,5
428EA-08	428E ER 20	8	21	31,5
428EA-09	428E ER 20	9	21	31,5
428EA-10	428E ER 20	10	21	31,5
428EA-11	428E ER 20	11	21	31,5
428EA-12	428E ER 20	12	21	31,5
428EA-13	428E ER 20	13	21	31,5

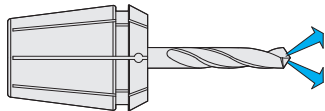

9

Hinweis:

Nur das Nennmaß DCONWS kann gespannt werden, mit Dichtstopfen für Innenkühlung (einsetzbar bis 21 bar). Um eine optimale Abdichtung zu erreichen, muss das zu spannende Werkzeug auf der ganzen Länge der geschliffenen Bohrung der Spannzange eingespannt werden.

Note:

Only nominal size DCONWS can be clamped with sealing plug for internal cooling (applicable up to 21 bar). In order to achieve an optimum sealing the tool must be clamped on the complete length of the ground drill of the collet.

Observation:

Seulement la dimension nominale DCONWS peut être tendu avec des bochons 'étan héité pour le refroidissement interne (peut être utilisé jusqu'à 21 bar). Afin d'obtenir un étanchéité optimal l'outil doit être serré sur la lon gueur complète de l'alésage rectifié de la pince.



Collets steel sealed for high pressure cooling up to 120 bar | ER system

Pinces de serrage, étanche pour arrosage de haute pression 120 bar | Type ER



Verwendung:

Zur Aufnahme von Werkzeugen mit Innenkühlung und Zylinderschaft in Spannfutter DIN 6499

Application:

For mounting straight-shank tools with internal cooling in collet chucks DIN 6499

Application:

Pour le serrage des outils avec le refroidissement interne et avec queue cylindrique dans mandrins à pinces DIN 6499

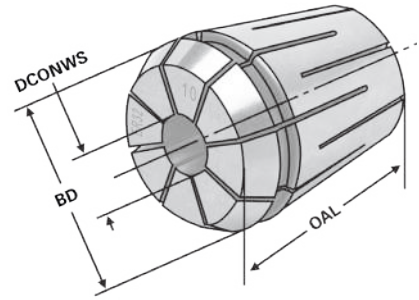

Bestell-Nr. Order no. Référence	Größe Size Taille	DCONWS	BD	OAL
428EH-03	428E ER 20	3	21	31,5
428EH-04	428E ER 20	4	21	31,5
428EH-05	428E ER 20	5	21	31,5
428EH-06	428E ER 20	6	21	31,5
428EH-07	428E ER 20	7	21	31,5
428EH-08	428E ER 20	8	21	31,5
428EH-09	428E ER 20	9	21	31,5
428EH-10	428E ER 20	10	21	31,5
428EH-11	428E ER 20	11	21	31,5
428EH-12	428E ER 20	12	21	31,5
428EH-13	428E ER 20	13	21	31,5

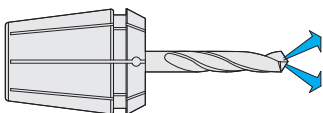

Hinweis:

Nur das Nennmaß DCONWS kann gespannt werden (einsetzbar bis 120 bar). Um eine optimale Abdichtung zu erreichen, muss das zu spannende Werkzeug auf der ganzen Länge der geschliffenen Bohrung der Spannzange eingespannt werden.

Note:

Only nominal size DCONWS can be clamped (applicable up to 120 bar). In order to achieve an optimum sealing the tool must be clamped on the complete length of the ground drill of the collet.

Observation:

Seulement la dimension nominale DCONWS peut être tendu (peut être utilisé jusqu'à 120 bar). Afin d'obtenir un étanchéité optimal l'outil doit être serré sur la longueur complète de l'alésage rectifié de la pince.



Collets with cooling channels ISO 15488 B (DIN 6499 B) | ER system
 Pincettes de serrage avec canaux d'arrosage ISO 15488 B (DIN 6499 B) | Type ER



Verwendung:
 Zur Aufnahme von Werkzeugen mit Zylinderschaft in Spannfutter DIN 6499.

Application:
 For mounting straight-shank tools in collet chucks DIN 6499.

Application:
 Pour le serrage d'outils avec queue cylindrique dans mandrins à pincettes DIN 6499.

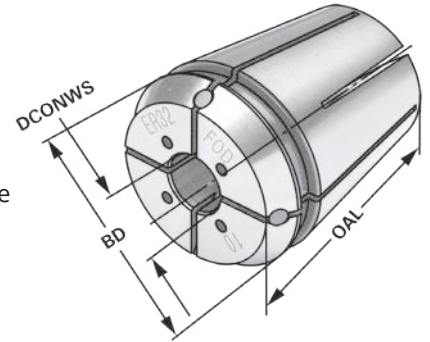

Bestell-Nr. Order no. Référence	Größe Size Taille	DCONWS	BD	OAL
428EC-04	428E ER 20	4	21	31,5
428EC-05	428E ER 20	5	21	31,5
428EC-06	428E ER 20	6	21	31,5
428EC-07	428E ER 20	7	21	31,5
428EC-08	428E ER 20	8	21	31,5
428EC-09	428E ER 20	9	21	31,5



Hinweis: Nur das Nennmaß DCONWS kann gespannt werden, mit Kühlkanälen. Einsetzbar bis 21 bar. Um eine optimale Abdichtung zu erreichen, muss das zu spannende Werkzeug auf der ganzen Länge der geschliffenen Bohrung der Spannzange eingespannt werden.

Note: Only nominal size DCONWS can be clamped, with cooling channels. Applicable up to 21 bar. In order to achieve an optimum sealing the tool must be clamped on the complete length of the ground drill of the collet.

Observation: Seulement la dimension nominale DCONWS peut être tendu, avec canaux d'arrosage. Peut être utilisé jusqu'à 21 bar. Afin d'obtenir un étanchéité optimal l'outil doit être serré sur la longueur complète de l'alésage rectifié de la pince.

9



ISO 15488 B (DIN 6499 B) | ER System

Collets with cooling channels along the boring ISO 15488 B (DIN 6499 B) | ER system

Pinces de serrage avec canaux d'arrosage le long de l'alésage ISO 15488 B (DIN 6499 B) | Type ER



Verwendung:

Zur Aufnahme von Werkzeugen mit Zylinderschaft in Spannfutter DIN 6499.

Application:

For mounting straight-shank tools in collet chucks DIN 6499.

Application:

Pour le serrage d'outils avec queue cylindrique dans mandrins à pinces DIN 6499.

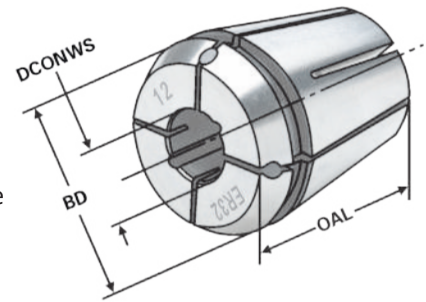

Bestell-Nr. Order no. Référence	Größe Size Taille	DCONWS	BD	OAL
428ECC-04	428E ER 20	4	21	31,5
428ECC-05	428E ER 20	5	21	31,5
428ECC-06	428E ER 20	6	21	31,5
428ECC-07	428E ER 20	7	21	31,5
428ECC-08	428E ER 20	8	21	31,5
428ECC-09	428E ER 20	9	21	31,5



Hinweis:

Nur das Nennmaß DCONWS kann gespannt werden, mit Kühlkanälen entlang der Bohrung. Einsetzbar bis 21 bar. Um eine optimale Abdichtung zu erreichen, muss das zu spannende Werkzeug auf der ganzen Länge der geschliffenen Bohrung der Spannzange eingespannt werden.

Note:

Only nominal size DCONWS can be clamped, with cooling channels along the boring. Applicable up to 21 bar. In order to achieve an optimum sealing the tool must be clamped on the complete length of the ground drill of the collet.

Observation:

Seulement la dimension nominale DCONWS peut être tendu, avec canaux d'arrosage le long de l'alésage. Peut être utilisé jusqu'à 21 bar. Afin d'obtenir un étanchéité optimal l'outil doit être serré sur la longueur complète de l'alésage rectifié de la pince.

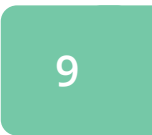



Präzisionsspannzangen ISO 15488 B (DIN 6499 B) | ER System - Edelstahl

Precision collets ISO 15488 B (DIN 6499 B) | ER system - stainless steel

Pinces de serrage de précision ISO 15488 B (DIN 6499 B) | Type ER - acier inoxydable



Verwendung:

Zur Aufnahme von Werkzeugen mit Zylinderschaft in Spannfutter DIN 6499. Für Anwendungen im HSC-Bereich und für hochpräzise Bearbeitungsergebnisse.

Application:

For mounting straight-shank tools in collet chucks DIN 6499. To use for high speed cutting and high precision milling.

Application:

Pour le serrage d'outils avec queue cylindrique dans mandrins à pinces DIN 6499. Pour l'usage dans le coupe à grande vitesse et dans l'usinage à grande précision.

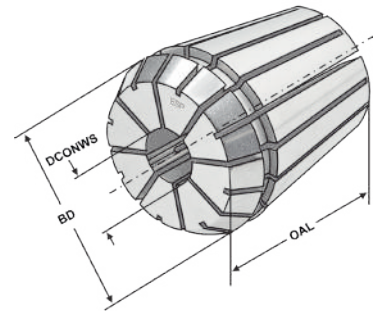

ISO 15488 ER $\leq 5\mu\text{m}$ Inox



Bestell-Nr. Order no. Référence	Größe Size Taille	DCONWS	BD	OAL
428ESP-03	428E ER 20	3,0 – 2,5	21	31,5
428ESP-035	428E ER 20	3,5 – 3,0	21	31,5
428ESP-04	428E ER 20	4,0 – 3,5	21	31,5
428ESP-045	428E ER 20	4,5 – 4,0	21	31,5
428ESP-05	428E ER 20	5,0 – 4,5	21	31,5
428ESP-055	428E ER 20	5,5 – 5,0	21	31,5
428ESP-06	428E ER 20	6,0 – 5,5	21	31,5
428ESP-065	428E ER 20	6,5 – 6,0	21	31,5
428ESP-07	428E ER 20	7,0 – 6,5	21	31,5
428ESP-075	428E ER 20	7,5 – 7,0	21	31,5
428ESP-08	428E ER 20	8,0 – 7,5	21	31,5
428ESP-085	428E ER 20	8,5 – 8,0	21	31,5
428ESP-09	428E ER 20	9,0 – 8,5	21	31,5
428ESP-095	428E ER 20	9,5 – 9,0	21	31,5
428ESP-10	428E ER 20	10,0 – 9,5	21	31,5
428ESP-105	428E ER 20	10,5 – 10,0	21	31,5
428ESP-11	428E ER 20	11,0 – 10,5	21	31,5
428ESP-115	428E ER 20	11,5 – 11,0	21	31,5
428ESP-12	428E ER 20	12,0 – 11,5	21	31,5
428ESP-125	428E ER 20	12,5 – 12,0	21	31,5
428ESP-13	428E ER 20	13,0 – 12,5	21	31,5

9

Hinweis: Spannbereich bis -0,5 mm
Note: Clamping capacity up to -0,5 mm
Observation: Serrage jusqu'à -0,5 mm

- Rostfrei
- Edelstahl 1.4021 x 20Cr13
- Höhere Wiederholgenauigkeit
- Spannzangenbohrung gehont
- Besonders geeignet für Drahterosion

- Rustproof
- Stainless steel 1.4021 x 20Cr13
- Higher repeat-accuracy
- Honed collet boring
- Especially suitable for wire EDM

- Inoxydable
- Acier affiné 1.4021 x 20Cr13
- Répétabilité supérieure
- Alésage de pince aiguisé
- Convient particulièrement pour le fil EDM



Tap collets - ISO 15488 B (DIN 6499 B) | ER system

Pinces de serrage pour tarauds - ISO 15488 B (DIN 6499 B) | Type ER



Verwendung:

Für Maschinen mit steigungssynchronem Vorschub. Zur verdrehsicheren Spannung von Gewindebohrern.

Application:

For machines with rigid tapping. For safe clamping of taps.

Application:

Pour machines avec broche synchronisée. Pour le serrage stable de tarauds.

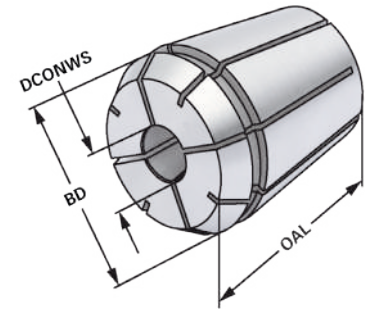

Bestell-Nr. Order no. Référence	Größe Size Taille	DCONWS	DRVS	BD	OAL
428G-3527	428E ER 20	3,5	2,7	20,8	31,5
428G-43	428E ER 20	4	3	20,8	31,5
428G-4534	428E ER 20	4,5	3,4	20,8	31,5
428G-649	428E ER 20	6	4,9	20,8	31,5
428G-755	428E ER 20	7	5,5	20,8	31,5
428G-862	428E ER 20	8	6,2	20,8	31,5
428G-97	428E ER 20	9	7	20,8	31,5
428G-108	428E ER 20	10	8	20,8	31,5



K Gewindebohrer Spannzangen mit Kühkanalbohrungen | ER System

Tap collets with cooling channels | ER system
Pinces de serrage avec canaux d'arrosage | Type ER

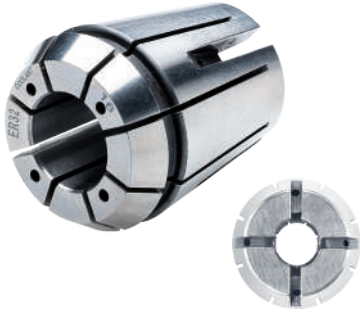

Verwendung:
Für Maschinen mit steigungssynchronem Vorschub. Zur verdsicheren Spannung von Gewindebohrern.

Application:
For machines with rigid tapping.
For safe clamping of taps.

Application:
Pour machines avec broche synchronisée.
Pour le serrage stable de tarauds.

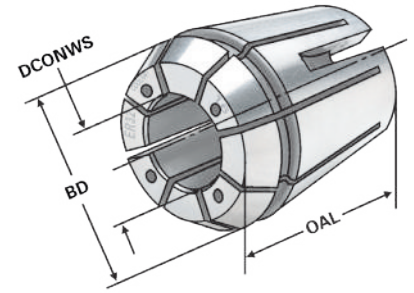

Bestell-Nr. Order no. Référence	Größe Size Taille	DCONWS	DRVS	BD	OAL
428GC-3527	428E ER 20	3,5	2,7	20,8	31,5
428GC-43	428E ER 20	4	3	20,8	31,5
428GC-4534	428E ER 20	4,5	3,4	20,8	31,5
428GC-649	428E ER 20	6	4,9	20,8	31,5
428GC-755	428E ER 20	7	5,5	20,8	31,5
428GC-862	428E ER 20	8	6,2	20,8	31,5
428GC-97	428E ER 20	9	7	20,8	31,5
428GC-108	428E ER 20	10	8	20,8	31,5



9



9.33

Tap collets with seals | ER system
 Pincés de serrage pour tarauds | Type ER



Verwendung:
 Für Maschinen mit steigungssynchronem Vorschub. Zur verkehrsicheren Spannung von Gewindebohrern.

Application:
 For machines with rigid tapping.
 For safe clamping of taps.

Application:
 Pour machines avec broche synchronisée.
 Pour le serrage stable de tarauds.

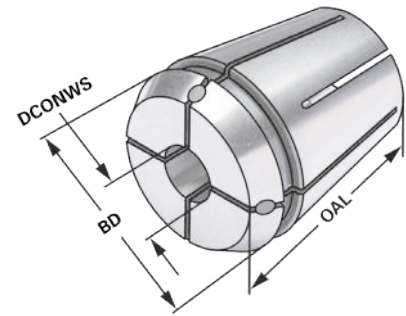

Bestell-Nr. Order no. Référence	Größe Size Taille	DCONWS	DRVS	BD	OAL
428GA-3527	428E ER 20	3,5	2,7	20,8	31,5
428GA-43	428E ER 20	4	3	20,8	31,5
428GA-4534	428E ER 20	4,5	3,4	20,8	31,5
428GA-649	428E ER 20	6	4,9	20,8	31,5
428GA-755	428E ER 20	7	5,5	20,8	31,5
428GA-862	428E ER 20	8	6,2	20,8	31,5
428GA-97	428E ER 20	9	7	20,8	31,5
428GA-108	428E ER 20	10	8	20,8	31,5

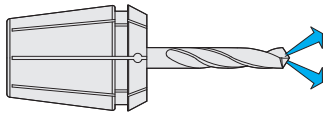

Collets ISO 15488 B (DIN 6499 B) | ER system
 Pincés de serrage ISO 15488 B (DIN 6499 B) | Type ER



Verwendung:
 Zur Aufnahme von Werkzeugen mit Zylinderschaft in Spannfutter DIN 6499.

Application:
 For mounting straight-shank tools in collet chucks DIN 6499.

Application:
 Pour le serrage d'outils avec queue cylindrique dans mandrins à pincés DIN 6499.

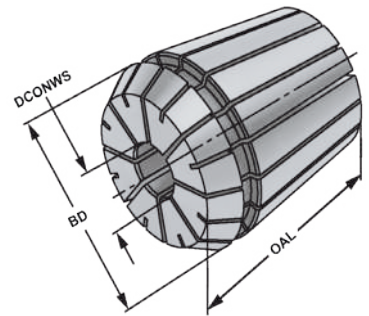

ISO
15488

ER

≤ 15µm

13.04

Bestell-Nr. Order no. Référence	Größe Size Taille	DCONWS	BD	OAL
430E-02	430E ER 25	2 - 1,5	26	34
430E-03	430E ER 25	3 - 2,0	26	34
430E-04	430E ER 25	4 - 3,0	26	34
430E-05	430E ER 25	5 - 4,0	26	34
430E-06	430E ER 25	6 - 5,0	26	34
430E-07	430E ER 25	7 - 6,0	26	34
430E-08	430E ER 25	8 - 7,0	26	34
430E-09	430E ER 25	9 - 8,0	26	34
430E-10	430E ER 25	10 - 9,0	26	34
430E-11	430E ER 25	11 - 10,0	26	34
430E-12	430E ER 25	12 - 11,0	26	34
430E-13	430E ER 25	13 - 12,0	26	34
430E-14	430E ER 25	14 - 13,0	26	34
430E-15	430E ER 25	15 - 14,0	26	34
430E-16	430E ER 25	16 - 15,0	26	34

9

Hinweis: Hohe Flexibilität: Großer Spannbereich bis -1 mm
Note: High flexibility: Large holding capacity up to -1 mm
Observation: Grande capacité de serrage jusqu'à -1 mm



Precision collets ISO 15488 B (DIN 6499 B) | ER system

Pinces de serrage de précision ISO 15488 B (DIN 6499 B) | Type ER



Verwendung:

Zur Aufnahme von Werkzeugen mit Zylinderschaft in Spannfutter DIN 6499. Für Anwendungen im HSC-Bereich und für hochpräzise Bearbeitungsergebnisse.

Application:

For mounting straight-shank tools in collet chucks DIN 6499. To use for high speed cutting and high precision milling.

Application:

Pour le serrage d'outils avec queue cylindrique dans mandrins à pinces DIN 6499. Pour l'usage dans le coupage à grande vitesse et dans l'usinage à grande précision.

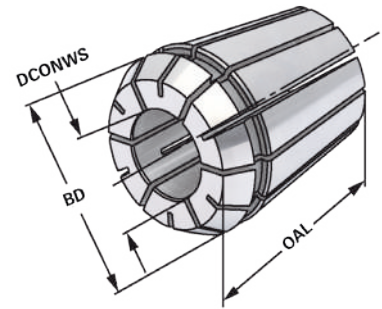

Bestell-Nr. Order no. Référence	Größe Size Taille	DCONWS	BD	OAL
430EP-02	430E ER 25	2 - 1,5	26	34
430EP-03	430E ER 25	3 - 2,0	26	34
430EP-04	430E ER 25	4 - 3,0	26	34
430EP-05	430E ER 25	5 - 4,0	26	34
430EP-06	430E ER 25	6 - 5,0	26	34
430EP-07	430E ER 25	7 - 6,0	26	34
430EP-08	430E ER 25	8 - 7,0	26	34
430EP-09	430E ER 25	9 - 8,0	26	34
430EP-10	430E ER 25	10 - 9,0	26	34
430EP-11	430E ER 25	11 - 10,0	26	34
430EP-12	430E ER 25	12 - 11,0	26	34
430EP-13	430E ER 25	13 - 12,0	26	34
430EP-14	430E ER 25	14 - 13,0	26	34
430EP-15	430E ER 25	15 - 14,0	26	34
430EP-16	430E ER 25	16 - 15,0	26	34

Hinweis: Hohe Flexibilität: Großer Spannbereich bis -1 mm
Note: High flexibility: Large holding capacity up to -1 mm
Observation: Grande capacité de serrage jusqu'à -1 mm





Collets sealed for IC - ISO 15488 B (DIN 6499 B) | ER system

Pinces de serrage avec joint d'étanchéité pour IC - ISO 15488 B (DIN 6499 B) | Type ER



Verwendung:

Zur Aufnahme von Werkzeugen mit Innenkühlung und Zylinderschaft in Spannfutter DIN 6499

Application:

For mounting straight-shank tools with internal cooling in collet chucks DIN 6499

Application:

Pour le serrage des outils avec le refroidissement interne et avec queue cylindrique dans mandrins à pincés DIN 6499

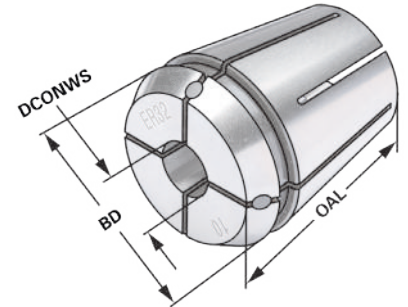

Bestell-Nr. Order no. Référence	Größe Size Taille	DCONWS	BD	OAL
430EA-03	430E ER 25	3	26	34
430EA-04	430E ER 25	4	26	34
430EA-05	430E ER 25	5	26	34
430EA-06	430E ER 25	6	26	34
430EA-07	430E ER 25	7	26	34
430EA-08	430E ER 25	8	26	34
430EA-09	430E ER 25	9	26	34
430EA-10	430E ER 25	10	26	34
430EA-11	430E ER 25	11	26	34
430EA-12	430E ER 25	12	26	34
430EA-13	430E ER 25	13	26	34
430EA-14	430E ER 25	14	26	34
430EA-15	430E ER 25	15	26	34
430EA-16	430E ER 25	16	26	34

9

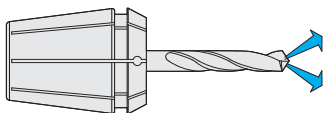

Hinweis:

Nur das Nennmaß DCONWS kann gespannt werden, mit Dichtstopfen für Innenkühlung (einsetzbar bis 21 bar). Um eine optimale Abdichtung zu erreichen, muss das zu spannende Werkzeug auf der ganzen Länge der geschliffenen Bohrung der Spannzange eingespannt werden.

Note:

Only nominal size DCONWS can be clamped with sealing plug for internal cooling (applicable up to 21 bar). In order to achieve an optimum sealing the tool must be clamped on the complete length of the ground drill of the collet.

Observation:

Seulement la dimension nominale DCONWS peut être tendu avec des bochons 'étan héité pour le refroidissement interne (peut être utilisé jusqu'à 21 bar). Afin d'obtenir un étanchéité optimal l'outil doit être serré sur la lon gueur complète de l'alésage rectifié de la pince.



Collets steel sealed for high pressure cooling up to 120 bar | ER system

Pinces de serrage, étanche pour arrosage de haute pression 120 bar | Type ER



Verwendung:

Zur Aufnahme von Werkzeugen mit Innenkühlung und Zylinderschaft in Spannfutter DIN 6499

Application:

For mounting straight-shank tools with internal cooling in collet chucks DIN 6499

Application:

Pour le serrage des outils avec le refroidissement interne et avec queue cylindrique dans mandrins à pinces DIN 6499

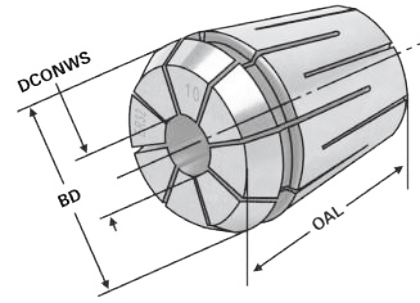

Bestell-Nr. Order no. Référence	Größe Size Taille	DCONWS	BD	OAL
430EH-03	430E ER 25	3	26	34
430EH-04	430E ER 25	4	26	34
430EH-05	430E ER 25	5	26	34
430EH-06	430E ER 25	6	26	34
430EH-07	430E ER 25	7	26	34
430EH-08	430E ER 25	8	26	34
430EH-09	430E ER 25	9	26	34
430EH-10	430E ER 25	10	26	34
430EH-11	430E ER 25	11	26	34
430EH-12	430E ER 25	12	26	34
430EH-13	430E ER 25	13	26	34
430EH-14	430E ER 25	14	26	34
430EH-15	430E ER 25	15	26	34
430EH-16	430E ER 25	16	26	34

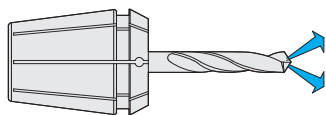

Hinweis:

Nur das Nennmaß DCONWS kann gespannt werden (einsetzbar bis 120 bar). Um eine optimale Abdichtung zu erreichen, muss das zu spannende Werkzeug auf der ganzen Länge der geschliffenen Bohrung der Spannzange eingespannt werden.

Note:

Only nominal size DCONWS can be clamped (applicable up to 120 bar). In order to achieve an optimum sealing the tool must be clamped on the complete length of the ground drill of the collet.

Observation:

Seulement la dimension nominale DCONWS peut être tendu (peut être utilisé jusqu'à 120 bar). Afin d'obtenir un étanchéité optimal l'outil doit être serré sur la longueur complète de l'alésage rectifié de la pince.



Collets with cooling channels ISO 15488 B (DIN 6499 B) | ER system
 Pincettes de serrage avec canaux d'arrosage ISO 15488 B (DIN 6499 B) | Type ER



Verwendung:
 Zur Aufnahme von Werkzeugen mit Zylinderschaft in Spannfutter DIN 6499.

Application:
 For mounting straight-shank tools in collet chucks DIN 6499.

Application:
 Pour le serrage d'outils avec queue cylindrique dans mandrins à pincettes DIN 6499.

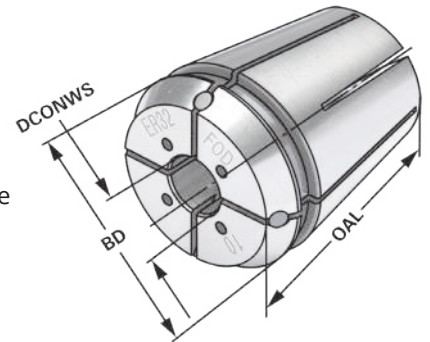

Bestell-Nr. Order no. Référence	Größe Size Taille	DCONWS	BD	OAL
430EC-03	430E ER 25	3	26	34
430EC-04	430E ER 25	4	26	34
430EC-05	430E ER 25	5	26	34
430EC-06	430E ER 25	6	26	34
430EC-07	430E ER 25	7	26	34
430EC-08	430E ER 25	8	26	34
430EC-09	430E ER 25	9	26	34
430EC-10	430E ER 25	10	26	34
430EC-11	430E ER 25	11	26	34
430EC-12	430E ER 25	12	26	34
430EC-13	430E ER 25	13	26	34
430EC-14	430E ER 25	14	26	34



9

Hinweis: Nur das Nennmaß DCONWS kann gespannt werden, mit Kühlkanälen. Einsetzbar bis 21 bar. Um eine optimale Abdichtung zu erreichen, muss das zu spannende Werkzeug auf der ganzen Länge der geschliffenen Bohrung der Spannzange eingespannt werden.

Note: Only nominal size DCONWS can be clamped, with cooling channels. Applicable up to 21 bar. In order to achieve an optimum sealing the tool must be clamped on the complete length of the ground drill of the collet.

Observation: Seulement la dimension nominale DCONWS peut être tendu, avec canaux d'arrosage. Peut être utilisé jusqu'à 21 bar. Afin d'obtenir un étanchéité optimal l'outil doit être serré sur la longueur complète de l'alésage rectifié de la pince.



ISO 15488 B (DIN 6499 B) | ER System

Collets with cooling channels along the boring ISO 15488 B (DIN 6499 B) | ER system

Pinces de serrage avec canaux d'arrosage le long de l'alésage ISO 15488 B (DIN 6499 B) | Type ER



Verwendung:

Zur Aufnahme von Werkzeugen mit Zylinderschaft in Spannfutter DIN 6499.

Application:

For mounting straight-shank tools in collet chucks DIN 6499.

Application:

Pour le serrage d'outils avec queue cylindrique dans mandrins à pinces DIN 6499.

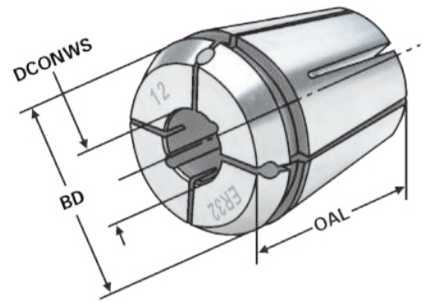

Bestell-Nr. Order no. Référence	Größe Size Taille	DCONWS	BD	OAL
430ECC-03	430E ER 25	3	26	34
430ECC-04	430E ER 25	4	26	34
430ECC-05	430E ER 25	5	26	34
430ECC-06	430E ER 25	6	26	34
430ECC-07	430E ER 25	7	26	34
430ECC-08	430E ER 25	8	26	34
430ECC-09	430E ER 25	9	26	34
430ECC-10	430E ER 25	10	26	34
430ECC-11	430E ER 25	11	26	34
430ECC-12	430E ER 25	12	26	34
430ECC-13	430E ER 25	13	26	34
430ECC-14	430E ER 25	14	26	34



Hinweis:

Nur das Nennmaß DCONWS kann gespannt werden, mit Kühlkanälen entlang der Bohrung. Einsetzbar bis 21 bar. Um eine optimale Abdichtung zu erreichen, muss das zu spannende Werkzeug auf der ganzen Länge der geschliffenen Bohrung der Spannzange eingespannt werden.

Note:

Only nominal size DCONWS can be clamped, with cooling channels along the boring. Applicable up to 21 bar. In order to achieve an optimum sealing the tool must be clamped on the complete length of the ground drill of the collet.

Observation:

Seulement la dimension nominale DCONWS peut être tendu, avec canaux d'arrosage le long de l'alésage. Peut être utilisé jusqu'à 21 bar. Afin d'obtenir un étanchéité optimal l'outil doit être serré sur la longueur complète de l'alésage rectifié de la pince.





Präzisionsspannzangen ISO 15488 B (DIN 6499 B) | ER System - Edelstahl

Precision collets ISO 15488 B (DIN 6499 B) | ER system - stainless steel

Pinces de serrage de précision ISO 15488 B (DIN 6499 B) | Type ER - acier inoxydable



Verwendung:

Zur Aufnahme von Werkzeugen mit Zylinderschaft in Spannfutter DIN 6499. Für Anwendungen im HSC-Bereich und für hochpräzise Bearbeitungsergebnisse.

Application:

For mounting straight-shank tools in collet chucks DIN 6499. To use for high speed cutting and high precision milling.

Application:

Pour le serrage d'outils avec queue cylindrique dans mandrins à pinces DIN 6499. Pour l'usage dans le coupe à grande vitesse et dans l'usinage à grande précision.

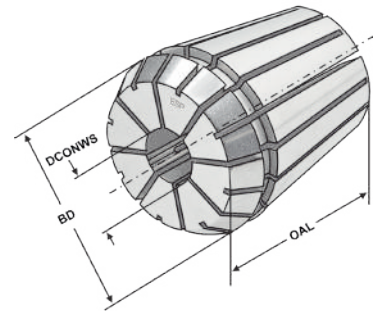

ISO 15488	ER	≤ 5µm	Inox
-----------	----	-------	------

13.04

Bestell-Nr. Order no. Référence	Größe Size Taille	DCONWS	BD	OAL
430ESP-03	430E ER 25	3,0 – 2,5	26	34
430ESP-035	430E ER 25	3,5 – 3,0	26	34
430ESP-04	430E ER 25	4,0 – 3,5	26	34
430ESP-045	430E ER 25	4,5 – 4,0	26	34
430ESP-05	430E ER 25	5,0 – 4,5	26	34
430ESP-055	430E ER 25	5,5 – 5,0	26	34
430ESP-06	430E ER 25	6,0 – 5,5	26	34
430ESP-065	430E ER 25	6,5 – 6,0	26	34
430ESP-07	430E ER 25	7,0 – 6,5	26	34
430ESP-075	430E ER 25	7,5 – 7,0	26	34
430ESP-08	430E ER 25	8,0 – 7,5	26	34
430ESP-085	430E ER 25	8,5 – 8,0	26	34
430ESP-09	430E ER 25	9,0 – 8,5	26	34
430ESP-095	430E ER 25	9,5 – 9,0	26	34
430ESP-10	430E ER 25	10,0 – 9,5	26	34
430ESP-105	430E ER 25	10,5 – 10,0	26	34
430ESP-11	430E ER 25	11,0 – 10,5	26	34
430ESP-115	430E ER 25	11,5 – 11,0	26	34
430ESP-12	430E ER 25	12,0 – 11,5	26	34
430ESP-125	430E ER 25	12,5 – 12,0	26	34
430ESP-13	430E ER 25	13,0 – 12,5	26	34
430ESP-135	430E ER 25	13,5 – 13,0	26	34
430ESP-14	430E ER 25	14,0 – 13,5	26	34
430ESP-145	430E ER 25	14,5 – 14,0	26	34
430ESP-15	430E ER 25	15,0 – 14,5	26	34
430ESP-155	430E ER 25	15,5 – 15,0	26	34
430ESP-16	430E ER 25	16,0 – 15,5	26	34

9

- Rostfrei
- Edelstahl 1.4021 x 20Cr13
- Höhere Wiederholgenauigkeit
- Spannzangenbohrung gehont
- Besonders geeignet für Drahterosion

- Rustproof
- Stainless steel 1.4021 x 20Cr13
- Higher repeat-accuracy
- Honed collet boring
- Especially suitable fore wire EDM

Hinweis: Spannbereich bis -0,5 mm
Note: Clamping capacity up to -0,5 mm
Observation: Serrage jusqu'à -0,5 mm

- Inoxydable
- Acier affiné 1.4021 x 20Cr13
- Répétabilité supérieure
- Alésage de pince aiguisé
- Convient particulièrement pour le fil EDM



Tap collets - ISO 15488 B (DIN 6499 B) | ER system

Pinces de serrage pour tarauds - ISO 15488 B (DIN 6499 B) | Type ER



Verwendung:

Für Maschinen mit steigungssynchronem Vorschub. Zur verdrehsicheren Spannung von Gewindebohrern.

Application:

For machines with rigid tapping. For safe clamping of taps.

Application:

Pour machines avec broche synchronisée. Pour le serrage stable de tarauds.

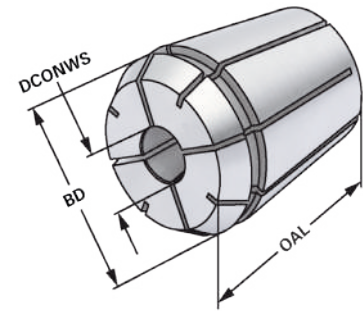

Bestell-Nr. Order no. Référence	Größe Size Taille	DCONWS	DRVS	BD	OAL
430G-3527	430E ER 25	3,5	2,7	26	34
430G-43	430E ER 25	4	3	26	34
430G-4534	430E ER 25	4,5	3,4	26	34
430G-649	430E ER 25	6	4,9	26	34
430G-755	430E ER 25	7	5,5	26	34
430G-862	430E ER 25	8	6,2	26	34
430G-97	430E ER 25	9	7	26	34
430G-108	430E ER 25	10	8	26	34
430G-119	430E ER 25	11	9	26	34
430G-129	430E ER 25	12	9	26	34



K Gewindebohrer Spannzangen mit Kühkanalbohrungen | ER System

Tap collets with cooling channels | ER system
Pinces de serrage avec canaux d'arrosage | Type ER



Verwendung:
Für Maschinen mit steigungssynchronem Vorschub. Zur verdrehsicheren Spannung von Gewindebohrern.

Application:
For machines with rigid tapping.
For safe clamping of taps.

Application:
Pour machines avec broche synchronisée.
Pour le serrage stable de tarauds.

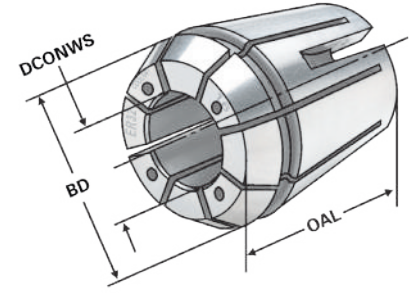

Bestell-Nr. Order no. Référence	Größe Size Taille	DCONWS	DRVS	BD	OAL
430GC-3527	430E ER 25	3,5	2,7	25,8	34
430GC-43	430E ER 25	4	3	25,8	34
430GC-4534	430E ER 25	4,5	3,4	25,8	34
430GC-649	430E ER 25	6	4,9	25,8	34
430GC-755	430E ER 25	7	5,5	25,8	34
430GC-862	430E ER 25	8	6,2	25,8	34
430GC-97	430E ER 25	9	7	25,8	34
430GC-108	430E ER 25	10	8	25,8	34
430GC-119	430E ER 25	11	9	25,8	34
430GC-129	430E ER 25	12	9	25,8	34



9



9.43

Tap collets with seals | ER system
Pincés de serrage pour tarauds | Type ER



Verwendung:
Für Maschinen mit steigungssynchronem Vorschub. Zur verkehrsicheren Spannung von Gewindebohrern.

Application:
For machines with rigid tapping.
For safe clamping of taps.

Application:
Pour machines avec broche synchronisée.
Pour le serrage stable de tarauds.

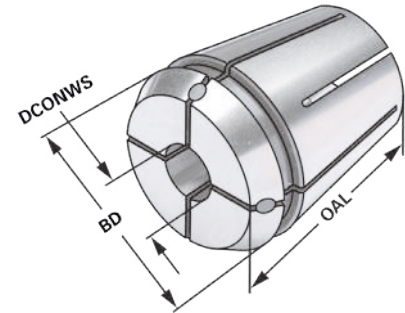

Bestell-Nr. Order no. Référence	Größe Size Taille	DCONWS	DRVS	BD	OAL
430GA-3527	430E ER 25	3,5	2,7	25,8	34
430GA-43	430E ER 25	4	3	25,8	34
430GA-4534	430E ER 25	4,5	3,4	25,8	34
430GA-649	430E ER 25	6	4,9	25,8	34
430GA-755	430E ER 25	7	5,5	25,8	34
430GA-862	430E ER 25	8	6,2	25,8	34
430GA-97	430E ER 25	9	7	25,8	34
430GA-108	430E ER 25	10	8	25,8	34
430GA-119	430E ER 25	11	9	25,8	34
430GA-129	430E ER 25	12	9	25,8	34

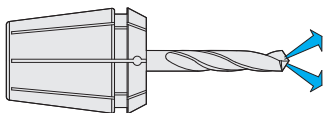



Technische Datenblätter, STEP/STL Modelle für die Simulation der NC-Programme und DXF-Zeichnungen zur Erstellung des Einrichteblattes stehen Online zur Verfügung.

Technical data sheets, STEP/STL models for the simulation of NC programs and DXF drawings to create the tooling sheet are online available.

Fiches techniques, STEP/STL modèles techniques pour la simulation de programmes CN et dessins DXF pour créer la feuille d'installation sont disponible online.

Sie können unsere Kataloge entweder direkt im Browser betrachten oder sie auf Ihren PC, Smartphone oder Tablet herunterladen (PDF-Reader notwendig).

You can view our catalogues either directly in the browser or download to your PC, smartphone or tablet (PDF reader required).

Vous pouvez consulter nos catalogues directement dans le navigateur ou télécharger sur votre PC, smartphone ou tablet (lecteur PDF requis).

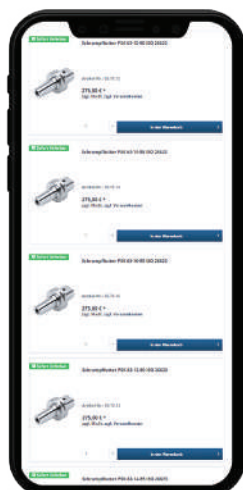

Auf unserer Internetseite können Sie die Lagerverfügbarkeit prüfen - auch auf Mobilgeräten.

On our website you can check the stock availability - also on mobile devices.

Vous pouvez également vérifier la disponibilité de nos produits sur le site Internet - ainsi que sur vos appareils

Collets ISO 15488 B (DIN 6499 B) | ER system

Pinces de serrage ISO 15488 B (DIN 6499 B) | Type ER



Verwendung:

Zur Aufnahme von Werkzeugen mit Zylinderschaft in Spannfutter DIN 6499.

Application:

For mounting straight-shank tools in collet chucks DIN 6499.

Application:

Pour le serrage d'outils avec queue cylindrique dans mandrins à pinces DIN 6499.

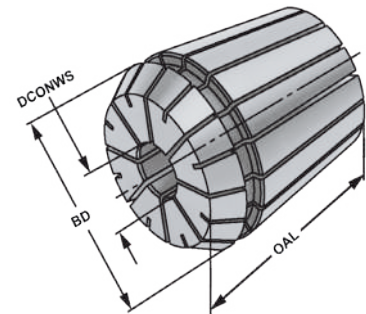

Bestell-Nr. Order no. Référence	Größe Size Taille	DCONWS	BD	OAL
470E-02	470E ER 32	2 - 1,5	33	40
470E-03	470E ER 32	3 - 2,0	33	40
470E-04	470E ER 32	4 - 3,0	33	40
470E-05	470E ER 32	5 - 4,0	33	40
470E-06	470E ER 32	6 - 5,0	33	40
470E-07	470E ER 32	7 - 6,0	33	40
470E-08	470E ER 32	8 - 7,0	33	40
470E-09	470E ER 32	9 - 8,0	33	40
470E-10	470E ER 32	10 - 9,0	33	40
470E-11	470E ER 32	11 - 10,0	33	40
470E-12	470E ER 32	12 - 11,0	33	40
470E-13	470E ER 32	13 - 12,0	33	40
470E-14	470E ER 32	14 - 13,0	33	40
470E-15	470E ER 32	15 - 14,0	33	40
470E-16	470E ER 32	16 - 15,0	33	40
470E-17	470E ER 32	17 - 16,0	33	40
470E-18	470E ER 32	18 - 17,0	33	40
470E-19	470E ER 32	19 - 18,0	33	40
470E-20	470E ER 32	20 - 19,0	33	40

Hinweis: Hohe Flexibilität: Großer Spannbereich bis -1 mm
Note: High flexibility: Large holding capacity up to -1 mm
Observation: Grande capacité de serrage jusqu'à -1 mm



Precision collets ISO 15488 B (DIN 6499 B) | ER system

Pinces de serrage de précision ISO 15488 B (DIN 6499 B) | Type ER



Verwendung:

Zur Aufnahme von Werkzeugen mit Zylinderschaft in Spannfutter DIN 6499. Für Anwendungen im HSC-Bereich und für hochpräzise Bearbeitungsergebnisse.

Application:

For mounting straight-shank tools in collet chucks DIN 6499. To use for high speed cutting and high precision milling.

Application:

Pour le serrage d'outils avec queue cylindrique dans mandrins à pinces DIN 6499. Pour l'usage dans le coupage à grande vitesse et dans l'usinage à grande précision.

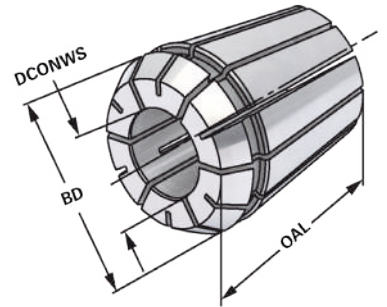

Bestell-Nr. Order no. Référence	Größe Size Taille	DCONWS	BD	OAL
470EP-02	470E ER 32	2 - 1,5	33	40
470EP-03	470E ER 32	3 - 2,0	33	40
470EP-04	470E ER 32	4 - 3,0	33	40
470EP-05	470E ER 32	5 - 4,0	33	40
470EP-06	470E ER 32	6 - 5,0	33	40
470EP-07	470E ER 32	7 - 6,0	33	40
470EP-08	470E ER 32	8 - 7,0	33	40
470EP-09	470E ER 32	9 - 8,0	33	40
470EP-10	470E ER 32	10 - 9,0	33	40
470EP-11	470E ER 32	11 - 10,0	33	40
470EP-12	470E ER 32	12 - 11,0	33	40
470EP-13	470E ER 32	13 - 12,0	33	40
470EP-14	470E ER 32	14 - 13,0	33	40
470EP-15	470E ER 32	15 - 14,0	33	40
470EP-16	470E ER 32	16 - 15,0	33	40
470EP-17	470E ER 32	17 - 16,0	33	40
470EP-18	470E ER 32	18 - 17,0	33	40
470EP-19	470E ER 32	19 - 18,0	33	40
470EP-20	470E ER 32	20 - 19,0	33	40

Hinweis: Hohe Flexibilität: Großer Spannbereich bis -1 mm
Note: High flexibility: Large holding capacity up to -1 mm
Observation: Grande capacité de serrage jusqu'à -1 mm



Precision collets ISO 15488 B (DIN 6499 B) | ER system | radial run-out of < 3 µm

Pinces de serrage de précision ISO 15488 B (DIN 6499 B) | Type ER | < 3 µm



Verwendung:

Zur Aufnahme von Werkzeugen mit Zylinderschaft in Spannfutter DIN 6499. Für Anwendungen im HSC-Bereich und für hochpräzise Bearbeitungsergebnisse.

Application:

For mounting straight-shank tools in collet chucks DIN 6499. To use for high speed cutting and high precision milling.

Application:

Pour le serrage d'outils avec queue cylindrique dans mandrins à pinces DIN 6499. Pour l'usage dans le coupage à grande vitesse et dans l'usinage à grande précision.

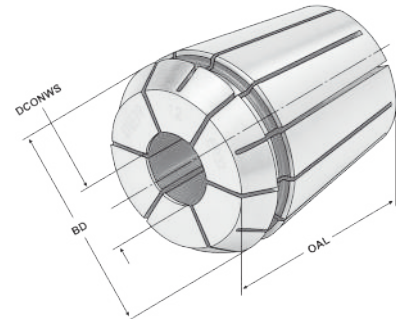

Bestell-Nr. Order no. Référence	Größe Size Taille	DCONWS	BD	OAL
470EPP-03	470E ER 32	3,0	33	40
470EPP-035	470E ER 32	3,5	33	40
470EPP-04	470E ER 32	4,0	33	40
470EPP-045	470E ER 32	4,5	33	40
470EPP-05	470E ER 32	5,0	33	40
470EPP-055	470E ER 32	5,5	33	40
470EPP-06	470E ER 32	6,0	33	40
470EPP-065	470E ER 32	6,5	33	40
470EPP-07	470E ER 32	7,0	33	40
470EPP-075	470E ER 32	7,5	33	40
470EPP-08	470E ER 32	8,0	33	40
470EPP-085	470E ER 32	8,5	33	40
470EPP-09	470E ER 32	9,0	33	40
470EPP-095	470E ER 32	9,5	33	40
470EPP-10	470E ER 32	10,0	33	40
470EPP-105	470E ER 32	10,5	33	40
470EPP-11	470E ER 32	11,0	33	40
470EPP-115	470E ER 32	11,5	33	40
470EPP-12	470E ER 32	12,0	33	40
470EPP-125	470E ER 32	12,5	33	40
470EPP-13	470E ER 32	13,0	33	40
470EPP-135	470E ER 32	13,5	33	40
470EPP-14	470E ER 32	14,0	33	40
470EPP-145	470E ER 32	14,5	33	40
470EPP-15	470E ER 32	15,0	33	40
470EPP-155	470E ER 32	15,5	33	40
470EPP-16	470E ER 32	16,0	33	40
470EPP-165	470E ER 32	16,5	33	40
470EPP-17	470E ER 32	17,0	33	40
470EPP-175	470E ER 32	17,5	33	40
470EPP-18	470E ER 32	18,0	33	40
470EPP-185	470E ER 32	18,5	33	40
470EPP-19	470E ER 32	19,0	33	40
470EPP-195	470E ER 32	19,5	33	40
470EPP-20	470E ER 32	20,0	33	40



Hinweis:

Note:

Observation:

Nur das Nennmaß DCONWS kann gespannt werden.

Only nominal size DCONWS can be clamped.

Seulement la dimension nominale DCONWS peut être tendu.



Collets sealed for IC - ISO 15488 B (DIN 6499 B) | ER system

Pinces de serrage avec joint d'étanchéité pour IC - ISO 15488 B (DIN 6499 B) | Type ER



Verwendung:

Zur Aufnahme von Werkzeugen mit Innenkühlung und Zylinderschaft in Spannfutter DIN 6499

Application:

For mounting straight-shank tools with internal cooling in collet chucks DIN 6499

Application:

Pour le serrage des outils avec le refroidissement interne et avec queue cylindrique dans mandrins à pinces DIN 6499

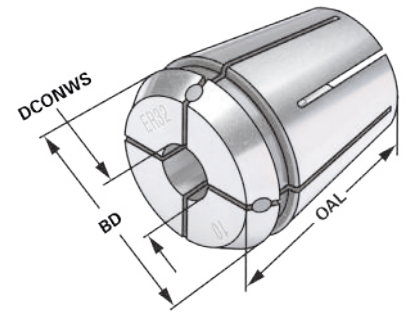

Bestell-Nr. Order no. Référence	Größe Size Taille	DCONWS	BD	OAL
470EA-03	470E ER 32	3	33	40
470EA-04	470E ER 32	4	33	40
470EA-05	470E ER 32	5	33	40
470EA-06	470E ER 32	6	33	40
470EA-07	470E ER 32	7	33	40
470EA-08	470E ER 32	8	33	40
470EA-09	470E ER 32	9	33	40
470EA-10	470E ER 32	10	33	40
470EA-11	470E ER 32	11	33	40
470EA-12	470E ER 32	12	33	40
470EA-13	470E ER 32	13	33	40
470EA-14	470E ER 32	14	33	40
470EA-15	470E ER 32	15	33	40
470EA-16	470E ER 32	16	33	40
470EA-17	470E ER 32	17	33	40
470EA-18	470E ER 32	18	33	40
470EA-19	470E ER 32	19	33	40
470EA-20	470E ER 32	20	33	40

9

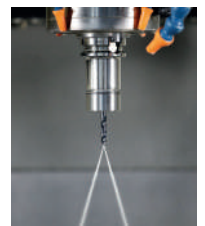
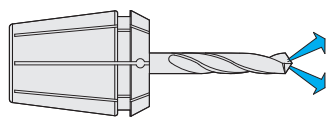

Hinweis:

Nur das Nennmaß DCONWS kann gespannt werden, mit Dichtstopfen für Innenkühlung (einsetzbar bis 21 bar). Um eine optimale Abdichtung zu erreichen, muss das zu spannende Werkzeug auf der ganzen Länge der geschliffenen Bohrung der Spannzange eingespannt werden.

Note:

Only nominal size DCONWS can be clamped with sealing plug for internal cooling (applicable up to 21 bar). In order to achieve an optimum sealing the tool must be clamped on the complete length of the ground drill of the collet.

Observation:

Seulement la dimension nominale DCONWS peut être tendu avec des bochons 'étanchéité' pour le refroidissement interne (peut être utilisé jusqu'à 21 bar). Afin d'obtenir un étanchéité optimal l'outil doit être serré sur la longueur complète de l'alésage rectifié de la pince.



ISO 15488 B (DIN 6499 B) | ER System

Collets with cooling channels along the boring ISO 15488 B (DIN 6499 B) | ER system

Pinces de serrage avec canaux d'arrosage le long de l'alésage ISO 15488 B (DIN 6499 B) | Type ER



Verwendung:

Zur Aufnahme von Werkzeugen mit Zylinderschaft in Spannfutter DIN 6499.

Application:

For mounting straight-shank tools in collet chucks DIN 6499.

Application:

Pour le serrage d'outils avec queue cylindrique dans mandrins à pinces DIN 6499.

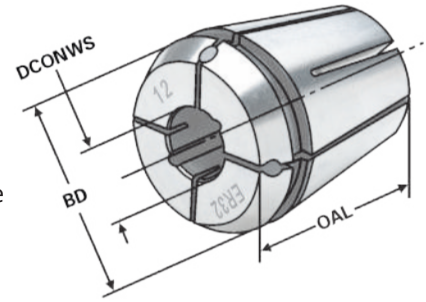

Bestell-Nr. Order no. Référence	Größe Size Taille	DCONWS	BD	OAL
470ECC-03	470E ER 32	3	33	40
470ECC-04	470E ER 32	4	33	40
470ECC-05	470E ER 32	5	33	40
470ECC-06	470E ER 32	6	33	40
470ECC-07	470E ER 32	7	33	40
470ECC-08	470E ER 32	8	33	40
470ECC-09	470E ER 32	9	33	40
470ECC-10	470E ER 32	10	33	40
470ECC-11	470E ER 32	11	33	40
470ECC-12	470E ER 32	12	33	40
470ECC-13	470E ER 32	13	33	40
470ECC-14	470E ER 32	14	33	40
470ECC-15	470E ER 32	15	33	40
470ECC-16	470E ER 32	16	33	40
470ECC-17	470E ER 32	17	33	40
470ECC-18	470E ER 32	18	33	40
470ECC-19	470E ER 32	19	33	40
470ECC-20	470E ER 32	20	33	40



Hinweis:

Nur das Nennmaß DCONWS kann gespannt werden, mit Kühlkanälen entlang der Bohrung. Einsetzbar bis 21 bar. Um eine optimale Abdichtung zu erreichen, muss das zu spannende Werkzeug auf der ganzen Länge der geschliffenen Bohrung der Spannzange eingespannt werden.

Note:

Only nominal size DCONWS can be clamped, with cooling channels along the boring. Applicable up to 21 bar. In order to achieve an optimum sealing the tool must be clamped on the complete length of the ground drill of the collet.

Observation:

Seulement la dimension nominale DCONWS peut être tendu, avec canaux d'arrosage le long de l'alésage. Peut être utilisé jusqu'à 21 bar. Afin d'obtenir un étanchéité optimal l'outil doit être serré sur la longueur complète de l'alésage rectifié de la pince.



Collets steel sealed for high pressure cooling up to 120 bar | ER system
Pincés de serrage, étanche pour arrosage de haute pression 120 bar | Type ER



Verwendung:
Zur Aufnahme von Werkzeugen mit Innenkühlung und Zylinderschaft in Spannfutter DIN 6499

Application:
For mounting straight-shank tools with internal cooling in collet chucks DIN 6499

Application:
Pour le serrage des outils avec le refroidissement interne et avec queue cylindrique dans mandrins à pincés DIN 6499

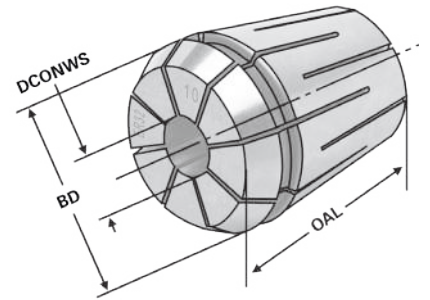

Bestell-Nr. Order no. Référence	Größe Size Taille	DCONWS	BD	OAL
470EH-03	470E ER 32	3	33	40
470EH-04	470E ER 32	4	33	40
470EH-05	470E ER 32	5	33	40
470EH-06	470E ER 32	6	33	40
470EH-07	470E ER 32	7	33	40
470EH-08	470E ER 32	8	33	40
470EH-09	470E ER 32	9	33	40
470EH-10	470E ER 32	10	33	40
470EH-11	470E ER 32	11	33	40
470EH-12	470E ER 32	12	33	40
470EH-13	470E ER 32	13	33	40
470EH-14	470E ER 32	14	33	40
470EH-15	470E ER 32	15	33	40
470EH-16	470E ER 32	16	33	40
470EH-17	470E ER 32	17	33	40
470EH-18	470E ER 32	18	33	40
470EH-19	470E ER 32	19	33	40
470EH-20	470E ER 32	20	33	40

9

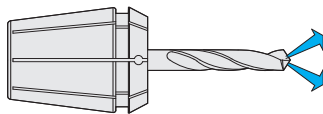

Hinweis: Nur das Nennmaß DCONWS kann gespannt werden (einsetzbar bis 120 bar). Um eine optimale Abdichtung zu erreichen, muss das zu spannende Werkzeug auf der ganzen Länge der geschliffenen Bohrung der Spannzange eingespannt werden.

Note: Only nominal size DCONWS can be clamped (applicable up to 120 bar). In order to achieve an optimum sealing the tool must be clamped on the complete length of the ground drill of the collet.

Observation: Seulement la dimension nominale DCONWS peut être tendu (peut être utilisé jusqu'à 120 bar). Afin d'obtenir un étanchéité optimal l'outil doit être serré sur la longueur complète de l'alésage rectifié de la pince.



ER System | Rundlauf < 3 µm

Precision collets steel sealed for high pressure cooling up to 120 bar | ER system | radial run-out of < 3 µm
 Pincés de serrage de précision, étanche pour arrosage de haute pression 120 bar | Type ER | < 3 µm



Verwendung:
 Zur Aufnahme von Werkzeugen mit Innenkühlung und Zylinderschaft in Spannfutter DIN 6499

Application:
 For mounting straight-shank tools with internal cooling in collet chucks DIN 6499

Application:
 Pour le serrage des outils avec le refroidissement interne et avec queue cylindrique dans mandrins à pincés DIN 6499

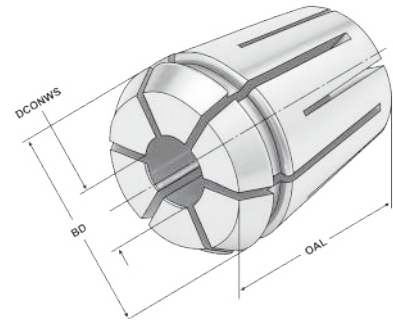

Bestell-Nr. Order no. Référence	Größe Size Taille	DCONWS	BD	OAL
470EHP-03	470E ER 32	3	33	40
470EHP-04	470E ER 32	4	33	40
470EHP-05	470E ER 32	5	33	40
470EHP-06	470E ER 32	6	33	40
470EHP-07	470E ER 32	7	33	40
470EHP-08	470E ER 32	8	33	40
470EHP-09	470E ER 32	9	33	40
470EHP-10	470E ER 32	10	33	40
470EHP-11	470E ER 32	11	33	40
470EHP-12	470E ER 32	12	33	40
470EHP-13	470E ER 32	13	33	40
470EHP-14	470E ER 32	14	33	40
470EHP-15	470E ER 32	15	33	40
470EHP-16	470E ER 32	16	33	40
470EHP-17	470E ER 32	17	33	40
470EHP-18	470E ER 32	18	33	40
470EHP-19	470E ER 32	19	33	40
470EHP-20	470E ER 32	20	33	40

9

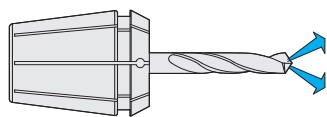

Hinweis: Nur das Nennmaß DCONWS kann gespannt werden (einsetzbar bis 120 bar). Um eine optimale Abdichtung zu erreichen, muss das zu spannende Werkzeug auf der ganzen Länge der geschliffenen Bohrung der Spannzange eingespannt werden.

Note: Only nominal size DCONWS can be clamped (applicable up to 120 bar). In order to achieve an optimum sealing the tool must be clamped on the complete length of the ground drill of the collet.

Observation: Seulement la dimension nominale DCONWS peut être tendu (peut être utilisé jusqu'à 120 bar). Afin d'obtenir un étanchéité optimal l'outil doit être serré sur la longueur complète de l'alésage rectifié de la pince.



K Spannzangen mit Dichtstopfen und Kühkanalbohrungen

ISO 15488 B (DIN 6499 B) | ER System

Collets with seals and cooling channels ISO 15488 B (DIN 6499 B) | ER system
 Pincés de serrage avec canaux d'arrosage ISO 15488 B (DIN 6499 B) | Type ER



Verwendung:
 Zur Aufnahme von Werkzeugen mit Zylinderschaft in Spannfutter DIN 6499.

Application:
 For mounting straight-shank tools in collet chucks DIN 6499.

Application:
 Pour le serrage d'outils avec queue cylindrique dans mandrins à pincés DIN 6499.

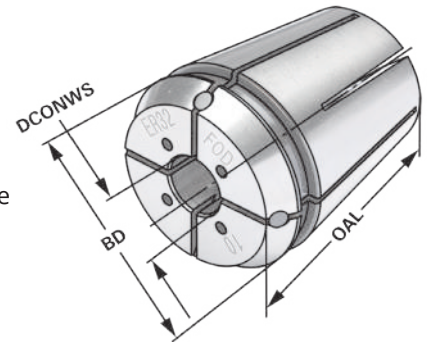

Bestell-Nr. Order no. Référence	Größe Size Taille	DCONWS	BD	OAL
470EC-03	470E ER 32	3	33	40
470EC-04	470E ER 32	4	33	40
470EC-05	470E ER 32	5	33	40
470EC-06	470E ER 32	6	33	40
470EC-07	470E ER 32	7	33	40
470EC-08	470E ER 32	8	33	40
470EC-09	470E ER 32	9	33	40
470EC-10	470E ER 32	10	33	40
470EC-11	470E ER 32	11	33	40
470EC-12	470E ER 32	12	33	40
470EC-13	470E ER 32	13	33	40
470EC-14	470E ER 32	14	33	40
470EC-15	470E ER 32	15	33	40
470EC-16	470E ER 32	16	33	40
470EC-17	470E ER 32	17	33	40
470EC-18	470E ER 32	18	33	40
470EC-19	470E ER 32	19	33	40
470EC-20	470E ER 32	20	33	40

9



Hinweis: Nur das Nennmaß DCONWS kann gespannt werden, mit Kühlkanälen. Einsetzbar bis 21 bar. Um eine optimale Abdichtung zu erreichen, muss das zu spannende Werkzeug auf der ganzen Länge der geschliffenen Bohrung der Spannzange eingespannt werden.

Note: Only nominal size DCONWS can be clamped, with cooling channels. Applicable up to 21 bar. In order to achieve an optimum sealing the tool must be clamped on the complete length of the ground drill of the collet.

Observation: Seulement la dimension nominale DCONWS peut être tendu, avec canaux d'arrosage. Peut être utilisé jusqu'à 21 bar. Afin d'obtenir un étanchéité optimal l'outil doit être serré sur la longueur complète de l'alésage rectifié de la pince.



ISO 15488 B (DIN 6499 B) | ER System

Precision collets with cooling channels ISO 15488 B (DIN 6499 B) | ER system | radial run-out of < 3 µm
 Pincettes de serrage de précision avec canaux d'arrosage ISO 15488 B (DIN 6499 B) | Type ER | < 3 µm



Verwendung:
 Zur Aufnahme von Werkzeugen mit Zylinderschaft in Spannfutter DIN 6499.

Application:
 For mounting straight-shank tools in collet chucks DIN 6499.

Application:
 Pour le serrage d'outils avec queue cylindrique dans mandrins à pincettes DIN 6499.

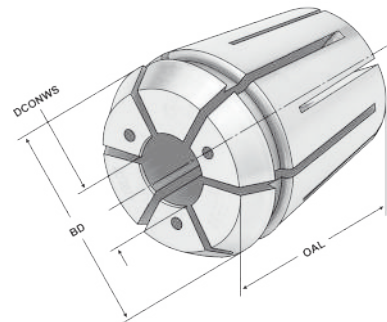

Bestell-Nr. Order no. Référence	Größe Size Taille	DCONWS	BD	OAL
470ECP-03	470E ER 32	3	33	40
470ECP-04	470E ER 32	4	33	40
470ECP-05	470E ER 32	5	33	40
470ECP-06	470E ER 32	6	33	40
470ECP-07	470E ER 32	7	33	40
470ECP-08	470E ER 32	8	33	40
470ECP-09	470E ER 32	9	33	40
470ECP-10	470E ER 32	10	33	40
470ECP-11	470E ER 32	11	33	40
470ECP-12	470E ER 32	12	33	40
470ECP-13	470E ER 32	13	33	40
470ECP-14	470E ER 32	14	33	40
470ECP-15	470E ER 32	15	33	40
470ECP-16	470E ER 32	16	33	40
470ECP-17	470E ER 32	17	33	40
470ECP-18	470E ER 32	18	33	40
470ECP-19	470E ER 32	19	33	40
470ECP-20	470E ER 32	20	33	40



Hinweis: Nur das Nennmaß DCONWS kann gespannt werden, mit Kühlkanälen entlang der Bohrung. Einsetzbar bis 120 bar. Um eine optimale Abdichtung zu erreichen, muss das zu spannende Werkzeug auf der ganzen Länge der geschliffenen Bohrung der Spannzange eingespannt werden.

Note: Only nominal size DCONWS can be clamped, with cooling channels along the boring. Applicable up to 120 bar. In order to achieve an optimum sealing the tool must be clamped on the complete length of the ground drill of the collet.

Observation: Seulement la dimension nominale DCONWS peut être tendu, avec canaux d'arrosage le long de l'alésage. Peut être utilisé jusqu'à 120 bar. Afin d'obtenir un étanchéité optimal l'outil doit être serré sur la longueur complète de l'alésage rectifié de la pince.





Präzisionsspannzangen ISO 15488 B (DIN 6499 B) | ER System - Edelstahl

Precision collets ISO 15488 B (DIN 6499 B) | ER system - stainless steel

Pinces de serrage de précision ISO 15488 B (DIN 6499 B) | Type ER - acier inoxydable



Verwendung:

Zur Aufnahme von Werkzeugen mit Zylinderschaft in Spannfutter DIN 6499. Für Anwendungen im HSC-Bereich und für hochpräzise Bearbeitungsergebnisse.

Application:

For mounting straight-shank tools in collet chucks DIN 6499. To use for high speed cutting and high precision milling.

Application:

Pour le serrage d'outils avec queue cylindrique dans mandrins à pinces DIN 6499. Pour l'usage dans le coupe à grande vitesse et dans l'usinage à grande précision.

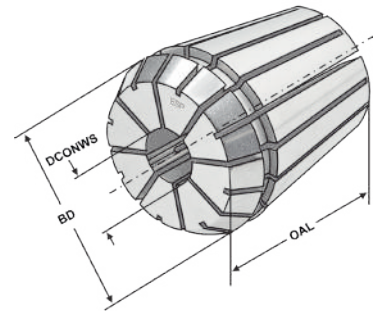

ISO 15488 ER $\leq 5\mu\text{m}$ Inox



Bestell-Nr. Order no. Référence	Größe Size Taille	DCONWS	BD	OAL
470ESP-03	470E ER 32	3,0 - 2,5	33	40
470ESP-035	470E ER 32	3,5 - 3,0	33	40
470ESP-04	470E ER 32	4,0 - 3,5	33	40
470ESP-045	470E ER 32	4,5 - 4,0	33	40
470ESP-05	470E ER 32	5,0 - 4,5	33	40
470ESP-055	470E ER 32	5,5 - 5,0	33	40
470ESP-06	470E ER 32	6,0 - 5,5	33	40
470ESP-065	470E ER 32	6,5 - 6,0	33	40
470ESP-07	470E ER 32	7,0 - 6,5	33	40
470ESP-075	470E ER 32	7,5 - 7,0	33	40
470ESP-08	470E ER 32	8,0 - 7,5	33	40
470ESP-085	470E ER 32	8,5 - 8,0	33	40
470ESP-09	470E ER 32	9,0 - 8,5	33	40
470ESP-095	470E ER 32	9,5 - 9,0	33	40
470ESP-10	470E ER 32	10,0 - 9,5	33	40
470ESP-105	470E ER 32	10,5 - 10,0	33	40
470ESP-11	470E ER 32	11,0 - 10,5	33	40
470ESP-115	470E ER 32	11,5 - 11,0	33	40
470ESP-12	470E ER 32	12,0 - 11,5	33	40
470ESP-125	470E ER 32	12,5 - 12,0	33	40
470ESP-13	470E ER 32	13,0 - 12,5	33	40
470ESP-135	470E ER 32	13,5 - 13,0	33	40
470ESP-14	470E ER 32	14,0 - 13,5	33	40
470ESP-145	470E ER 32	14,5 - 14,0	33	40
470ESP-15	470E ER 32	15,0 - 14,5	33	40
470ESP-155	470E ER 32	15,5 - 15,0	33	40
470ESP-16	470E ER 32	16,0 - 15,5	33	40
470ESP-165	470E ER 32	16,5 - 16,0	33	40
470ESP-17	470E ER 32	17,0 - 16,5	33	40
470ESP-175	470E ER 32	17,5 - 17,0	33	40
470ESP-18	470E ER 32	18,0 - 17,5	33	40
470ESP-185	470E ER 32	18,5 - 18,0	33	40
470ESP-19	470E ER 32	19,0 - 18,5	33	40
470ESP-195	470E ER 32	19,5 - 19,0	33	40
470ESP-20	470E ER 32	20,0 - 19,5	33	40

9



Hinweis:
Note:
Observation:

Spannbereich bis -0,5 mm
Clamping capacity up to -0,5 mm
Serrage jusqu'à -0,5 mm

Tap collets - ISO 15488 B (DIN 6499 B) | ER system

Pinces de serrage pour tarauds - ISO 15488 B (DIN 6499 B) | Type ER



Verwendung:

Für Maschinen mit steigungssynchronem Vorschub. Zur verdrehsicheren Spannung von Gewindebohrern.

Application:

For machines with rigid tapping. For safe clamping of taps.

Application:

Pour machines avec broche synchronisée. Pour le serrage stable de tarauds.

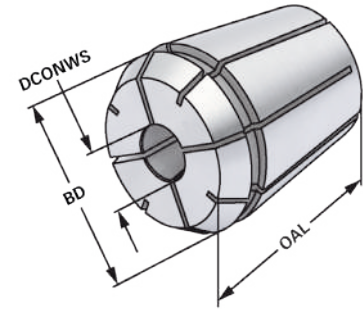

Bestell-Nr. Order no. Référence	Größe Size Taille	DCONWS	DRVS	BD	OAL
470G-4534	470E ER 32	4,5	3,4	33	40
470G-649	470E ER 32	6	4,9	33	40
470G-755	470E ER 32	7	5,5	33	40
470G-862	470E ER 32	8	6,2	33	40
470G-97	470E ER 32	9	7	33	40
470G-108	470E ER 32	10	8	33	40
470G-119	470E ER 32	11	9	33	40
470G-129	470E ER 32	12	9	33	40
470G-1411	470E ER 32	14	11	33	40
470G-1612	470E ER 32	16	12	33	40



K Gewindebohrer Spannzangen mit Kühkanalbohrungen | ER System

Tap collets with cooling channels | ER system
Pincés de serrage avec canaux d'arrosage | Type ER



Verwendung:
Für Maschinen mit steigungssynchronem Vorschub. Zur verdrehsicheren Spannung von Gewindebohrern.

Application:
For machines with rigid tapping.
For safe clamping of taps.

Application:
Pour machines avec broche synchronisée.
Pour le serrage stable de tarauds.

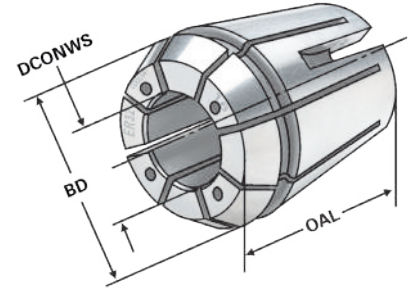

Bestell-Nr. Order no. Référence	Größe Size Taille	DCONWS	DRVS	BD	OAL
470GC-4534	470E ER 32	4,5	3,4	32,8	40
470GC-649	470E ER 32	6	4,9	32,8	40
470GC-755	470E ER 32	7	5,5	32,8	40
470GC-862	470E ER 32	8	6,2	32,8	40
470GC-97	470E ER 32	9	7	32,8	40
470GC-108	470E ER 32	10	8	32,8	40
470GC-119	470E ER 32	11	9	32,8	40
470GC-129	470E ER 32	12	9	32,8	40
470GC-1411	470E ER 32	14	11	32,8	40
470GC-1612	470E ER 32	16	12	32,8	40



9



9.57

KEMMLER

K24

Tap collets with seals | ER system

Pinces de serrage pour tarauds | Type ER



Verwendung:

Für Maschinen mit steigungssynchronem Vorschub. Zur verkehrsicheren Spannung von Gewindebohrern.

Application:

For machines with rigid tapping. For safe clamping of taps.

Application:

Pour machines avec broche synchronisée. Pour le serrage stable de tarauds.

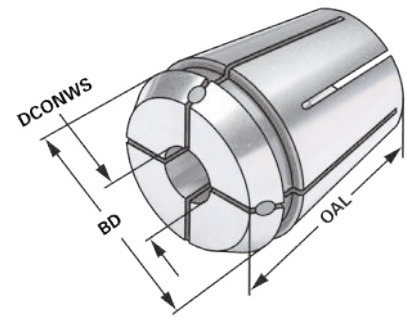

Bestell-Nr. Order no. Référence	Größe Size Taille	DCONWS	DRVS	BD	OAL
470GA-4534	470E ER 32	4,5	3,4	32,8	40
470GA-649	470E ER 32	6	4,9	32,8	40
470GA-755	470E ER 32	7	5,5	32,8	40
470GA-862	470E ER 32	8	6,2	32,8	40
470GA-97	470E ER 32	9	7	32,8	40
470GA-108	470E ER 32	10	8	32,8	40
470GA-119	470E ER 32	11	9	32,8	40
470GA-129	470E ER 32	12	9	32,8	40
470GA-1411	470E ER 32	14	11	32,8	40
470GA-1612	470E ER 32	16	12	32,8	40

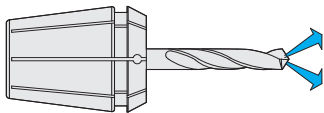

Collets ISO 15488 B (DIN 6499 B) | ER system

Pinces de serrage ISO 15488 B (DIN 6499 B) | Type ER



Verwendung:

Zur Aufnahme von Werkzeugen mit Zylinderschaft in Spannfutter DIN 6499.

Application:

For mounting straight-shank tools in collet chucks DIN 6499.

Application:

Pour le serrage d'outils avec queue cylindrique dans mandrins à pinces DIN 6499.

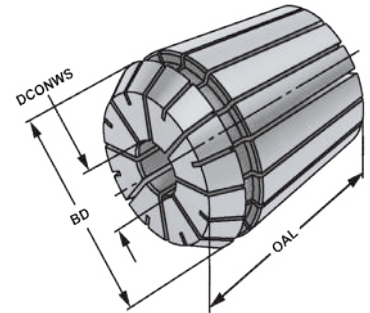

Bestell-Nr. Order no. Référence	Größe Size Taille	DCONWS	BD	OAL
472E-03	472E ER 40	3 - 2,5	41	46
472E-04	472E ER 40	4 - 3,0	41	46
472E-05	472E ER 40	5 - 4,0	41	46
472E-06	472E ER 40	6 - 5,0	41	46
472E-07	472E ER 40	7 - 6,0	41	46
472E-08	472E ER 40	8 - 7,0	41	46
472E-09	472E ER 40	9 - 8,0	41	46
472E-10	472E ER 40	10 - 9,0	41	46
472E-11	472E ER 40	11 - 10,0	41	46
472E-12	472E ER 40	12 - 11,0	41	46
472E-13	472E ER 40	13 - 12,0	41	46
472E-14	472E ER 40	14 - 13,0	41	46
472E-15	472E ER 40	15 - 14,0	41	46
472E-16	472E ER 40	16 - 15,0	41	46
472E-17	472E ER 40	17 - 16,0	41	46
472E-18	472E ER 40	18 - 17,0	41	46
472E-19	472E ER 40	19 - 18,0	41	46
472E-20	472E ER 40	20 - 19,0	41	46
472E-21	472E ER 40	21 - 20,0	41	46
472E-22	472E ER 40	22 - 21,0	41	46
472E-23	472E ER 40	23 - 22,0	41	46
472E-24	472E ER 40	24 - 23,0	41	46
472E-25	472E ER 40	25 - 24,0	41	46
472E-26	472E ER 40	26 - 25,0	41	46

Hinweis: Hohe Flexibilität: Großer Spannbereich bis -1 mm
Note: High flexibility: Large holding capacity up to -1 mm
Observation: Grande capacité de serrage jusqu'à -1 mm



Precision collets ISO 15488 B (DIN 6499 B) | ER system

Pinces de serrage de précision ISO 15488 B (DIN 6499 B) | Type ER



Verwendung:

Zur Aufnahme von Werkzeugen mit Zylinderschaft in Spannfutter DIN 6499. Für Anwendungen im HSC-Bereich und für hochpräzise Bearbeitungsergebnisse.

Application:

For mounting straight-shank tools in collet chucks DIN 6499. To use for high speed cutting and high precision milling.

Application:

Pour le serrage d'outils avec queue cylindrique dans mandrins à pinces DIN 6499. Pour l'usage dans le coupage à grande vitesse et dans l'usinage à grande précision.

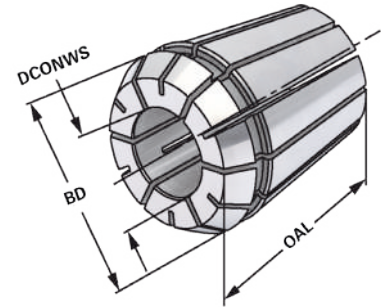

Bestell-Nr. Order no. Référence	Größe Size Taille	DCONWS	BD	OAL
472EP-03	472E ER 40	3 – 2,5	41	46
472EP-04	472E ER 40	4 – 3,0	41	46
472EP-05	472E ER 40	5 – 4,0	41	46
472EP-06	472E ER 40	6 – 5,0	41	46
472EP-07	472E ER 40	7 – 6,0	41	46
472EP-08	472E ER 40	8 – 7,0	41	46
472EP-09	472E ER 40	9 – 8,0	41	46
472EP-10	472E ER 40	10 – 9,0	41	46
472EP-11	472E ER 40	11 – 10,0	41	46
472EP-12	472E ER 40	12 – 11,0	41	46
472EP-13	472E ER 40	13 – 12,0	41	46
472EP-14	472E ER 40	14 – 13,0	41	46
472EP-15	472E ER 40	15 – 14,0	41	46
472EP-16	472E ER 40	16 – 15,0	41	46
472EP-17	472E ER 40	17 – 16,0	41	46
472EP-18	472E ER 40	18 – 17,0	41	46
472EP-19	472E ER 40	19 – 18,0	41	46
472EP-20	472E ER 40	20 – 19,0	41	46
472EP-21	472E ER 40	21 – 20,0	41	46
472EP-22	472E ER 40	22 – 21,0	41	46
472EP-23	472E ER 40	23 – 22,0	41	46
472EP-24	472E ER 40	24 – 23,0	41	46
472EP-25	472E ER 40	25 – 24,0	41	46
472EP-26	472E ER 40	26 – 25,0	41	46

Hinweis: Hohe Flexibilität: Großer Spannbereich bis -1 mm
Note: High flexibility: Large holding capacity up to -1 mm
Observation: Grande capacité de serrage jusqu'à -1 mm





Collets sealed for IC - ISO 15488 B (DIN 6499 B) | ER system

Pinces de serrage avec joint d'étanchéité pour IC - ISO 15488 B (DIN 6499 B) | Type ER



Verwendung:

Zur Aufnahme von Werkzeugen mit Innenkühlung und Zylinderschaft in Spannfutter DIN 6499

Application:

For mounting straight-shank tools with internal cooling in collet chucks DIN 6499

Application:

Pour le serrage des outils avec le refroidissement interne et avec queue cylindrique dans mandrins à pinces DIN 6499

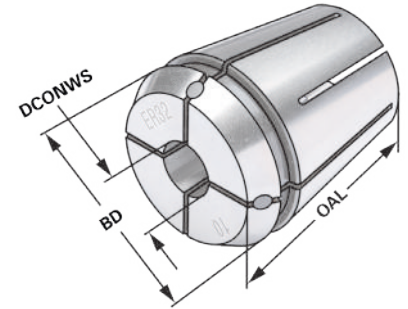

Bestell-Nr. Order no. Référence	Größe Size Taille	DCONWS	BD	OAL
472EA-03	472E ER 40	3	41	46
472EA-04	472E ER 40	4	41	46
472EA-05	472E ER 40	5	41	46
472EA-06	472E ER 40	6	41	46
472EA-07	472E ER 40	7	41	46
472EA-08	472E ER 40	8	41	46
472EA-09	472E ER 40	9	41	46
472EA-10	472E ER 40	10	41	46
472EA-11	472E ER 40	11	41	46
472EA-12	472E ER 40	12	41	46
472EA-13	472E ER 40	13	41	46
472EA-14	472E ER 40	14	41	46
472EA-15	472E ER 40	15	41	46
472EA-16	472E ER 40	16	41	46
472EA-17	472E ER 40	17	41	46
472EA-18	472E ER 40	18	41	46
472EA-19	472E ER 40	19	41	46
472EA-20	472E ER 40	20	41	46
472EA-21	472E ER 40	21	41	46
472EA-22	472E ER 40	22	41	46
472EA-23	472E ER 40	23	41	46
472EA-24	472E ER 40	24	41	46
472EA-25	472E ER 40	25	41	46
472EA-26	472E ER 40	26	41	46

9

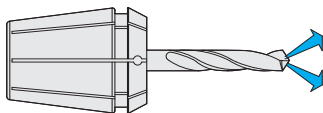

Hinweis:

Nur das Nennmaß DCONWS kann gespannt werden, mit Dichtstopfen für Innenkühlung (einsetzbar bis 21 bar). Um eine optimale Abdichtung zu erreichen, muss das zu spannende Werkzeug auf der ganzen Länge der geschliffenen Bohrung der Spannzange eingespannt werden.

Note:

Only nominal size DCONWS can be clamped with sealing plug for internal cooling (applicable up to 21 bar). In order to achieve an optimum sealing the tool must be clamped on the complete length of the ground drill of the collet.

Observation:

Seulement la dimension nominale DCONWS peut être tendu avec des bochons 'étan héité pour le refroidissement interne (peut être utilisé jusqu'à 21 bar). Afin d'obtenir un étanchéité optimal l'outil doit être serré sur la lon gueur complète de l'alésage rectifié de la pince.



Collets steel sealed for high pressure cooling up to 120 bar | ER system

Pinces de serrage, étanche pour arrosage de haute pression 120 bar | Type ER



Verwendung:

Zur Aufnahme von Werkzeugen mit Innenkühlung und Zylinderschaft in Spannfutter DIN 6499

Application:

For mounting straight-shank tools with internal cooling in collet chucks DIN 6499

Application:

Pour le serrage des outils avec le refroidissement interne et avec queue cylindrique dans mandrins à pinces DIN 6499

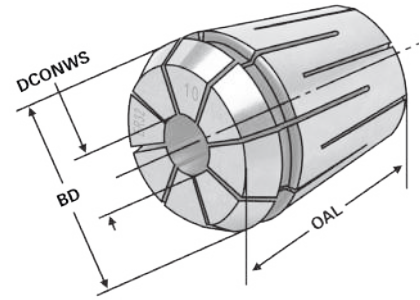

Bestell-Nr. Order no. Référence	Größe Size Taille	DCONWS	BD	OAL
472EH-04	472E ER 40	4	41	46
472EH-05	472E ER 40	5	41	46
472EH-06	472E ER 40	6	41	46
472EH-07	472E ER 40	7	41	46
472EH-08	472E ER 40	8	41	46
472EH-09	472E ER 40	9	41	46
472EH-10	472E ER 40	10	41	46
472EH-11	472E ER 40	11	41	46
472EH-12	472E ER 40	12	41	46
472EH-13	472E ER 40	13	41	46
472EH-14	472E ER 40	14	41	46
472EH-15	472E ER 40	15	41	46
472EH-16	472E ER 40	16	41	46
472EH-17	472E ER 40	17	41	46
472EH-18	472E ER 40	18	41	46
472EH-19	472E ER 40	19	41	46
472EH-20	472E ER 40	20	41	46
472EH-21	472E ER 40	21	41	46
472EH-22	472E ER 40	22	41	46
472EH-23	472E ER 40	23	41	46
472EH-24	472E ER 40	24	41	46
472EH-25	472E ER 40	25	41	46
472EH-26	472E ER 40	26	41	46

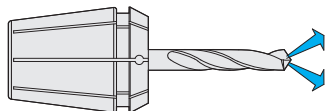

Hinweis:

Nur das Nennmaß DCONWS kann gespannt werden (einsetzbar bis 120 bar). Um eine optimale Abdichtung zu erreichen, muss das zu spannende Werkzeug auf der ganzen Länge der geschliffenen Bohrung der Spannzange eingespannt werden.

Note:

Only nominal size DCONWS can be clamped (applicable up to 120 bar). In order to achieve an optimum sealing the tool must be clamped on the complete length of the ground drill of the collet.

Observation:

Seulement la dimension nominale DCONWS peut être tendu (peut être utilisé jusqu'à 120 bar). Afin d'obtenir un étanchéité optimal l'outil doit être serré sur la longueur complète de l'alésage rectifié de la pince.





Collets with cooling channels ISO 15488 B (DIN 6499 B) | ER system

Pinces de serrage avec canaux d'arrosage ISO 15488 B (DIN 6499 B) | Type ER



Verwendung:

Zur Aufnahme von Werkzeugen mit Zylinderschaft in Spannfutter DIN 6499.

Application:

For mounting straight-shank tools in collet chucks DIN 6499.

Application:

Pour le serrage d'outils avec queue cylindrique dans mandrins à pinces DIN 6499.

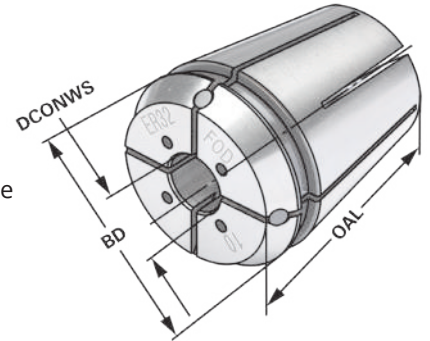

Bestell-Nr. Order no. Référence	Größe Size Taille	DCONWS	BD	OAL
472EC-04	472E ER 40	4	41	46
472EC-05	472E ER 40	5	41	46
472EC-06	472E ER 40	6	41	46
472EC-07	472E ER 40	7	41	46
472EC-08	472E ER 40	8	41	46
472EC-09	472E ER 40	9	41	46
472EC-10	472E ER 40	10	41	46
472EC-11	472E ER 40	11	41	46
472EC-12	472E ER 40	12	41	46
472EC-13	472E ER 40	13	41	46
472EC-14	472E ER 40	14	41	46
472EC-15	472E ER 40	15	41	46
472EC-16	472E ER 40	16	41	46
472EC-17	472E ER 40	17	41	46
472EC-18	472E ER 40	18	41	46
472EC-19	472E ER 40	19	41	46
472EC-20	472E ER 40	20	41	46
472EC-21	472E ER 40	21	41	46
472EC-22	472E ER 40	22	41	46
472EC-23	472E ER 40	23	41	46
472EC-24	472E ER 40	24	41	46
472EC-25	472E ER 40	25	41	46
472EC-26	472E ER 40	26	41	46

9



Hinweis:

Nur das Nennmaß DCONWS kann gespannt werden, mit Kühlkanälen. Einsetzbar bis 21 bar. Um eine optimale Abdichtung zu erreichen, muss das zu spannende Werkzeug auf der ganzen Länge der geschliffenen Bohrung der Spannzange eingespannt werden.

Note:

Only nominal size DCONWS can be clamped, with cooling channels. Applicable up to 21 bar. In order to achieve an optimum sealing the tool must be clamped on the complete length of the ground drill of the collet.

Observation:

Seulement la dimension nominale DCONWS peut être tendu, avec canaux d'arrosage. Peut être utilisé jusqu'à 21 bar. Afin d'obtenir un étanchéité optimal l'outil doit être serré sur la longueur complète de l'alésage rectifié de la pince.



ISO 15488 B (DIN 6499 B) | ER System

Collets with cooling channels along the boring ISO 15488 B (DIN 6499 B) | ER system

Pinces de serrage avec canaux d'arrosage le long de l'alésage ISO 15488 B (DIN 6499 B) | Type ER



Verwendung:

Zur Aufnahme von Werkzeugen mit Zylinderschaft in Spannfutter DIN 6499.

Application:

For mounting straight-shank tools in collet chucks DIN 6499.

Application:

Pour le serrage d'outils avec queue cylindrique dans mandrins à pinces DIN 6499.

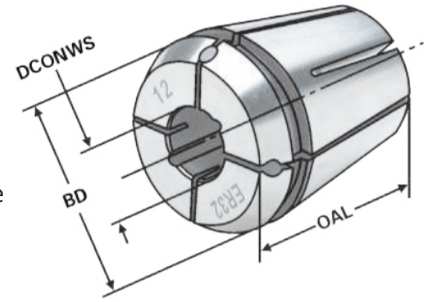

Bestell-Nr. Order no. Référence	Größe Size Taille	DCONWS	BD	OAL
472ECC-04	472E ER 40	4	41	46
472ECC-05	472E ER 40	5	41	46
472ECC-06	472E ER 40	6	41	46
472ECC-07	472E ER 40	7	41	46
472ECC-08	472E ER 40	8	41	46
472ECC-09	472E ER 40	9	41	46
472ECC-10	472E ER 40	10	41	46
472ECC-11	472E ER 40	11	41	46
472ECC-12	472E ER 40	12	41	46
472ECC-13	472E ER 40	13	41	46
472ECC-14	472E ER 40	14	41	46
472ECC-15	472E ER 40	15	41	46
472ECC-16	472E ER 40	16	41	46
472ECC-17	472E ER 40	17	41	46
472ECC-18	472E ER 40	18	41	46
472ECC-19	472E ER 40	19	41	46
472ECC-20	472E ER 40	20	41	46
472ECC-21	472E ER 40	21	41	46
472ECC-22	472E ER 40	22	41	46
472ECC-23	472E ER 40	23	41	46
472ECC-24	472E ER 40	24	41	46
472ECC-25	472E ER 40	25	41	46
472ECC-26	472E ER 40	26	41	46



Hinweis:

Nur das Nennmaß DCONWS kann gespannt werden, mit Kühlkanälen entlang der Bohrung. Einsetzbar bis 21 bar. Um eine optimale Abdichtung zu erreichen, muss das zu spannende Werkzeug auf der ganzen Länge der geschliffenen Bohrung der Spannzange eingespannt werden.

Note:

Only nominal size DCONWS can be clamped, with cooling channels along the boring. Applicable up to 21 bar. In order to achieve an optimum sealing the tool must be clamped on the complete length of the ground drill of the collet.

Observation:

Seulement la dimension nominale DCONWS peut être tendu, avec canaux d'arrosage le long de l'alésage. Peut être utilisé jusqu'à 21 bar. Afin d'obtenir un étanchéité optimal l'outil doit être serré sur la longueur complète de l'alésage rectifié de la pince.





Gewindebohrer Spannzangen - ISO 15488 B (DIN 6499 B) | ER System

Tap collets - ISO 15488 B (DIN 6499 B) | ER system

Pinces de serrage pour tarauds - ISO 15488 B (DIN 6499 B) | Type ER



Verwendung:

Für Maschinen mit steigungssynchronem Vorschub. Zur verkehrsicheren Spannung von Gewindebohrern.

Application:

For machines with rigid tapping. For safe clamping of taps.

Application:

Pour machines avec broche synchronisée. Pour le serrage stable de tarauds.

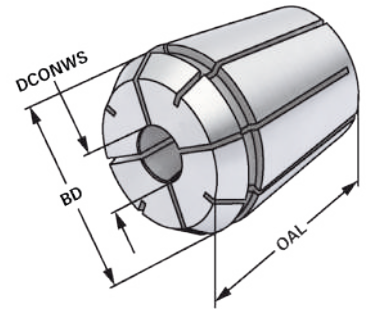

Bestell-Nr. Order no. Référence	Größe Size Taille	DCONWS	DRVS	BD	OAL
472G-649	472E ER 40	6	4,9	40,8	46
472G-755	472E ER 40	7	5,5	40,8	46
472G-862	472E ER 40	8	6,2	40,8	46
472G-97	472E ER 40	9	7	40,8	46
472G-108	472E ER 40	10	8	40,8	46
472G-119	472E ER 40	11	9	40,8	46
472G-129	472E ER 40	12	9	40,8	46
472G-1411	472E ER 40	14	11	40,8	46
472G-1612	472E ER 40	16	12	40,8	46
472G-18145	472E ER 40	18	14,5	40,8	46
472G-2016	472E ER 40	20	16	40,8	46



Tap collets with cooling channels | ER system
 Pince de serrage avec canaux d'arrosage | Type ER

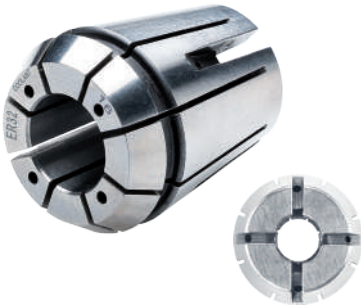

Verwendung:
 Für Maschinen mit steigungssynchronem Vorschub. Zur verdrehsicheren Spannung von Gewindebohrern.

Application:
 For machines with rigid tapping. For safe clamping of taps.

Application:
 Pour machines avec broche synchronisée. Pour le serrage stable de tarauds.

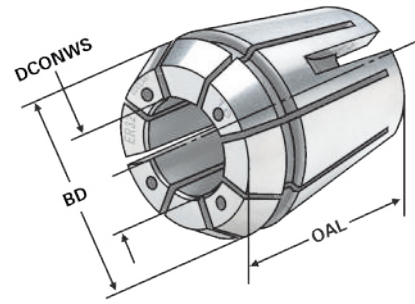

ISO 15488 ER $\leq 15\mu\text{m}$

13.04

Bestell-Nr. Order no. Référence	Größe Size Taille	DCONWS	DRVS	BD	OAL
472GC-649	472E ER 40	6	4,9	40,8	46
472GC-755	472E ER 40	7	5,5	40,8	46
472GC-862	472E ER 40	8	6,2	40,8	46
472GC-97	472E ER 40	9	7	40,8	46
472GC-108	472E ER 40	10	8	40,8	46
472GC-119	472E ER 40	11	9	40,8	46
472GC-129	472E ER 40	12	9	40,8	46
472GC-1411	472E ER 40	14	11	40,8	46
472GC-1612	472E ER 40	16	12	40,8	46
472GC-18145	472E ER 40	18	14,5	40,8	46
472GC-2016	472E ER 40	20	16	40,8	46



9.77 9.77 10.09



Gewindebohrer Spannzangen mit Dichtstopfen | ER System

Tap collets with seals | ER system
Pincettes de serrage pour tarauds | Type ER



Verwendung:
Für Maschinen mit steigungssynchronem Vorschub. Zur verdrehsicheren Spannung von Gewindebohrern.

Application:
For machines with rigid tapping. For safe clamping of taps.

Application:
Pour machines avec broche synchronisée. Pour le serrage stable de tarauds.

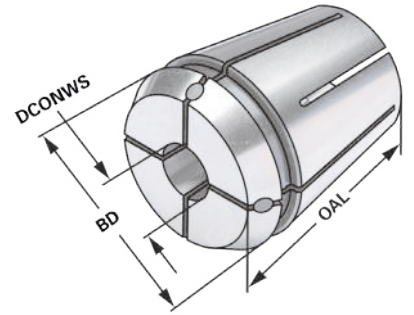

Bestell-Nr. Order no. Référence	Größe Size Taille	DCONWS	DRVS	BD	OAL
472GA-649	472E ER 40	6	4,9	40,8	46
472GA-755	472E ER 40	7	5,5	40,8	46
472GA-862	472E ER 40	8	6,2	40,8	46
472GA-97	472E ER 40	9	7	40,8	46
472GA-108	472E ER 40	10	8	40,8	46
472GA-119	472E ER 40	11	9	40,8	46
472GA-129	472E ER 40	12	9	40,8	46
472GA-1411	472E ER 40	14	11	40,8	46
472GA-1612	472E ER 40	16	12	40,8	46
472GA-18145	472E ER 40	18	14,5	40,8	46
472GA-2016	472E ER 40	20	16	40,8	46

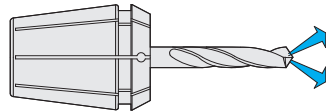

9



9.67

Präzisionsspannzangensätze im Holzsockel $\leq 0,003$ UP



Precision collet sets in wooden sockets $\leq 0,003$ UP

Jeux de pinces de précision dans socles en bois $\leq 0,003$ UP

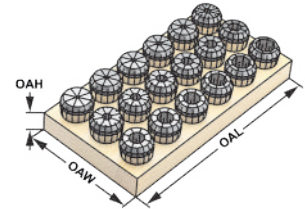

Bestell-Nr. Order no. Référence	Abmessung Size Dimension	OAL	OAW	OAH
470EPP-S	470E (ER 32; 15 tlg.) 3-4-5-6-7- 8- 9-10-11-12-14-15-16-18-20	190	150	30
470EHP-S	470E (ER 32; 15 tlg.) 3-4-5-6-7- 8- 9-10-11-12-14-15-16-18-20	190	150	30
470ECP-S	470E (ER 32; 15 tlg.) 3-4-5-6-7- 8- 9-10-11-12-14-15-16-18-20	190	150	30

Präzisionsspannzangensätze im Holzkasten $\leq 0,003$ UP

Precision collet sets in wooden boxes $\leq 0,003$ UP

Jeux de pinces de précision dans coffrets en bois $\leq 0,003$ UP

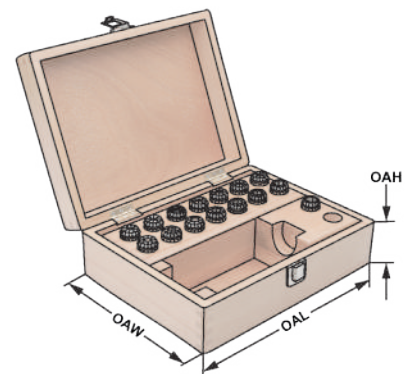

Bestell-Nr. Order no. Référence	Abmessung Size Dimension	OAL	OAW	OAH
701.470EPP.1	470E (ER 32; 15 St.) 3-4-5-6-7- 8- 9-10-11-12-14-15-16-18-20	360	235	70
701.470EHP.1	470E (ER 32; 15 St.) 3-4-5-6-7- 8- 9-10-11-12-14-15-16-18-20	360	235	70
701.470ECP.1	470E (ER 32; 15 St.) 3-4-5-6-7- 8- 9-10-11-12-14-15-16-18-20	360	235	70

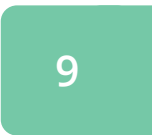

Spannzangensätze im Holzsockel $\leq 0,015$

Collet sets in wooden sockets $\leq 0,015$
 Jeux de pinces dans socles en bois $\leq 0,015$

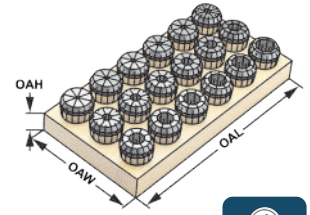

$\leq 15\mu\text{m}$



13.04

Bestell-Nr. Order no. Référence	Abmessung Size Dimension	OAL	OAW	OAH
415E - S	415E (OZ 16; 15 tlg.) 2-3-4-5-6-7-8-9-10-11-12-13-14-15-16	150	195	25
462E - S	462E (OZ 25; 15 tlg.) 4-5-6-7-8-9-10-11-12-14-16-18-20-22-25	290	240	30
467E - S	467E (OZ 32; 16 tlg.) 5-6-7-8-10-12-14-16-18-20-22-24-25-28-30-32	290	240	30
4008E - S	4008E (ER 11; 13 tlg.) 1-1,5-2-2,5-3-3,5-4-4,5-5-5,5-6-6,5-7	125	45	20
426E - S	426E (ER 16; 10 tlg.) 1-2-3-4-5-6-7-8-9-10	130	50	25
428E - S	428E (ER 20; 12 tlg.) 2-3-4-5-6-7-8-9-10-11-12-13	165	110	25
430E - S	430E (ER 25; 15 tlg.) 2-3-4-5-6-7-8-9-10-11-12-13-14-15-16	150	195	25
470E - S	470E (ER 32; 18 tlg.) 3-4-5-6-7-8-9-10-11-12-13-14-15-16-17-18-19-20	190	150	30
472E - S	472E (ER 40; 23 tlg.) 4-5-6-7-8-9-10-11-12-13-14-15-16-17-18-19-20-21-22-23-24-25-26	290	195	25

Spannzangensätze im Holzkasten $\leq 0,015$

Collet sets in wooden boxes $\leq 0,015$
 Jeux de pinces dans coffrets en bois $\leq 0,015$

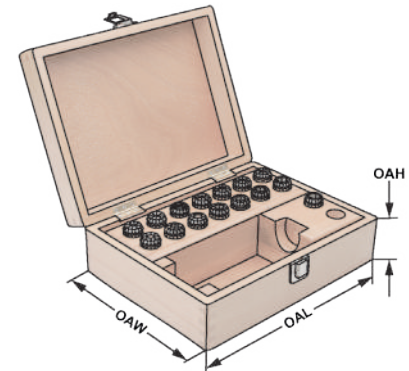

$\leq 15\mu\text{m}$

Bestell-Nr. Order no. Référence	Abmessung Size Dimension	OAL	OAW	OAH
701.415.1	415E (OZ 16; 15 St.) 2-3-4-5-6-7-8-9-10-11-12-13-14-15-16	360	235	70
701.462.1	462E (OZ 25; 15 St.) 4-5-6-7-8-9-10-11-12-14-16-18-20-22-25	360	235	70
701.467.1	467E (OZ 32; 16 St.) 5-6-7-8-10-12-14-16-18-20-22-24-25-28-30-32	360	235	70
701.4008.1	4008E (ER 11; 13 tlg.) 1-1,5-2-2,5-3-3,5-4-4,5-5-5,5-6-6,5-7	360	235	70
701.426.1	426E (ER 16; 10 St.) 1-2-3-4-5-6-7-8-9-10	360	235	70
701.428.1	428E (ER 20; 12 tlg.) 2-3-4-5-6-7-8-9-10-11-12-13	360	235	70
701.430.1	430E (ER 25; 15 St.) 2-3-4-5-6-7-8-9-10-11-12-13-14-15-16	360	235	70
701.470.1	470E (ER 32; 15 St.) 3-4-5-6-7-8-9-10-11-12-14-15-16-18-20	360	235	70
701.472.1	472E (ER 40; 16 St.) 4-5-6-7-8-9-10-11-12-14-16-18-20-22-24-26	360	235	70



Präzisionsspannzangensätze im Holzsockel $\leq 0,005$ UP



Precision collet sets in wooden sockets $\leq 0,005$ UP

Jeux de pinces de précision dans socles en bois $\leq 0,005$ UP

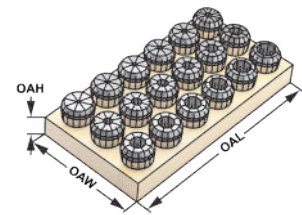

Bestell-Nr. Order no. Référence	Abmessung Size Dimension	OAL	OAW	OAH
415EP - S	415E (OZ 16; 15 tlg.) 2-3-4-5-6-7-8-9-10-11-12-13-14-15-16	150	195	25
462EP - S	462E (OZ 25; 15 tlg.) 4-5-6-7-8-9-10-11-12-14-16-18-20-22-25	290	240	30
467EP - S	467E (OZ 32; 16 tlg.) 5-6-7-8-10-12-14-16-18-20-22-24-25-28-30-32	290	240	30
4004EP - S	4004E (ER 8; 9 tlg.) 1-1,5-2-2,5-3-3,5-4-4,5-5	95	85	20
4008EP - S	4008E (ER 11; 13 tlg.) 1-1,5-2-2,5-3-3,5-4-4,5-5-5,5-6-6,5-7	95	85	20
426EP - S	426E (ER 16; 10 tlg.) 1-2-3-4-5-6-7-8-9-10	130	50	25
428EP - S	428E (ER 20; 12 tlg.) 2-3-4-5-6-7-8-9-10-11-12-13	165	110	25
430EP - S	430E (ER 25; 15 tlg.) 2-3-4-5-6-7-8-9-10-11-12-13-14-15-16	150	195	25
470EP - S	470E (ER 32; 18 tlg.) 3-4-5-6-7-8-9-10-11-12-13-14-15-16-17-18-19-20	190	150	30
472EP - S	472E (ER 40; 23 tlg.) 4-5-6-7-8-9-10-11-12-13-14-15-16-17-18-19-20-21-22-23-24-25-26	290	195	25

Präzisionsspannzangensätze im Holzkasten $\leq 0,005$ UP

Precision collet sets in wooden boxes $\leq 0,005$ UP

Jeux de pinces de précision dans coffrets en bois $\leq 0,005$ UP

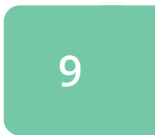
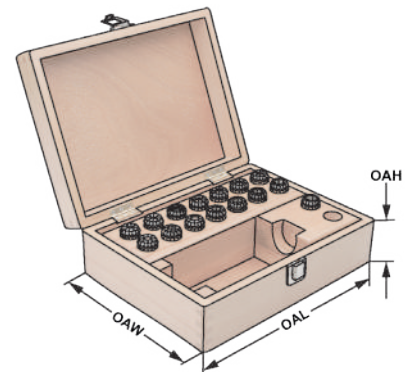

Bestell-Nr. Order no. Référence	Abmessung Size Dimension	OAL	OAW	OAH
701.415P.1	415E (OZ 16; 15 St.) 2-3-4-5-6-7-8-9-10-11-12-13-14-15-16	360	235	70
701.462P.1	462E (OZ 25; 15 St.) 4-5-6-7-8-9-10-11-12-14-16-18-20-22-25	360	235	70
701.467P.1	467E (OZ 32; 16 St.) 5-6-7-8-10-12-14-16-18-20-22-24-25-28-30-32	360	235	70
701.4008P.1	4008E (ER 11; 13 tlg.) 1-1,5-2-2,5-3-3,5-4-4,5-5-5,5-6-6,5-7	360	235	70
701.426P.1	426E (ER 16; 10 St.) 1-2-3-4-5-6-7-8-9-10	360	235	70
701.428P.1	428E (ER 20; 12 tlg.) 2-3-4-5-6-7-8-9-10-11-12-13	360	235	70
701.430P.1	430E (ER 25; 15 St.) 2-3-4-5-6-7-8-9-10-11-12-13-14-15-16	360	235	70
701.470P.1	470E (ER 32; 15 St.) 3-4-5-6-7-8-9-10-11-12-14-15-16-18-20	360	235	70
701.472P.1	472E (ER 40; 16 St.) 4-5-6-7-8-9-10-11-12-14-16-18-20-22-24-26	360	235	70

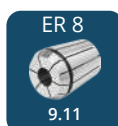



Spannzangen mit Abdichtung für IK - ISO 15488 B (DIN 6499 B) System ER

Collets with seal for IC - ISO 15488 B (DIN 6499 B) ER-system

Pinces de serrage avec joint d'étanchéité pour IC - ISO 15488 B (DIN 6499 B) système ER

Spannzangensätze im Holzsockel

Collet sets in wooden sockets

Jeux de pinces dans socles en bois

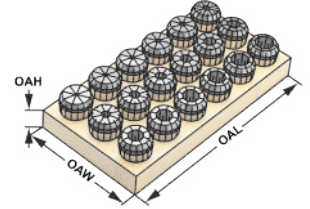

Bestell-Nr. Order no. Référence	Abmessung Size Dimension	OAL	OAW	OAH
426EA-S	426E (ER 16; 8 St.) 3-4-5-6-7-8-9-10	130	50	25
428EA-S	428E (ER 20; 11 St.) 3-4-5-6-7-8-9-10-11-12-13	165	110	25
430EA-S	430E (ER 25; 14 St.) 3-4-5-6-7-8-9-10-11-12-13-14-15-16	150	195	25
470EA-S	470E (ER 32; 15 St.) 3-4-5-6-7-8-9-10-11-12-14-15-16-18-20	190	150	30
472EA-S	472E (ER 40; 16 St.) 4-5-6-7-8-9-10-11-12-14-16-18-20-22-24-26	290	195	25

Spannzangensätze im Holzkasten

Collet sets in wooden boxes

Jeux de pinces dans coffrets en bois

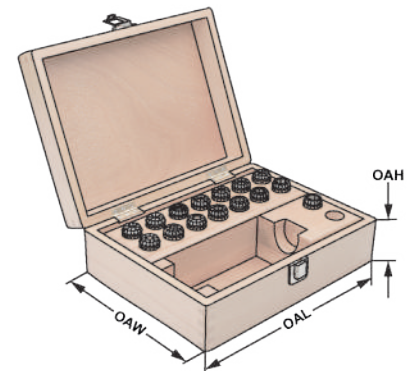

Bestell-Nr. Order no. Référence	Abmessung Size Dimension	OAL	OAW	OAH
701.426EA.1	426E (ER 16; 8 St.) 3-4-5-6-7-8-9-10	360	235	70
701.428EA.1	428E (ER 20; 11 St.) 3-4-5-6-7-8-9-10-11-12-13	360	235	70
701.430EA.1	430E (ER 25; 14 St.) 3-4-5-6-7-8-9-10-11-12-13-14-15-16	360	235	70
701.470EA.1	470E (ER 32; 15 St.) 3-4-5-6-7-8-9-10-11-12-14-15-16-18-20	360	235	70
701.472EA.1	472E (ER 40; 16 St.) 4-5-6-7-8-9-10-11-12-14-16-18-20-22-24-26	360	235	70



Collets with seals for high pressure cooling up to 120 bar

Pincettes de serrage, étanche pour arrosage de haute pression 120 bar

Spannzangensätze im Holzsockel

Collet sets in wooden sockets

Jeux de pincettes dans socles en bois

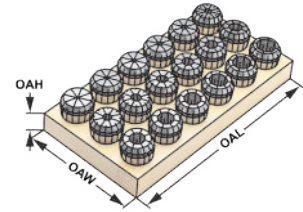

Bestell-Nr. Order no. Référence	Abmessung Size Dimension	OAL	OAW	OAH
426EH-S	426E (ER 16; 8 St.) 3-4-5-6-7-8-9-10	130	50	25
428EH-S	428E (ER 20; 11 St.) 3-4-5-6-7-8-9-10-11-12-13	165	110	25
430EH-S	430E (ER 25; 14 St.) 3-4-5-6-7-8-9-10-11-12-13-14-15-16	150	195	25
470EH-S	470E (ER 32; 15 St.) 3-4-5-6-7-8-9-10-11-12-14-15-16-18-20	190	150	30
472EH-S	472E (ER 40; 16 St.) 4-5-6-7-8-9-10-11-12-14-16-18-20-22-24-26	290	195	25

Spannzangensätze im Holzkasten

Collet sets in wooden boxes

Jeux de pincettes dans coffrets en bois

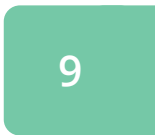
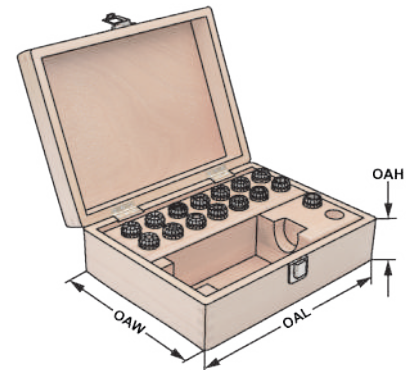

Bestell-Nr. Order no. Référence	Abmessung Size Dimension	OAL	OAW	OAH
701.426EH.1	426E (ER 16; 8 St.) 3-4-5-6-7-8-9-10	360	235	70
701.428EH.1	428E (ER 20; 11 St.) 3-4-5-6-7-8-9-10-11-12-13	360	235	70
701.430EH.1	430E (ER 25; 14 St.) 3-4-5-6-7-8-9-10-11-12-13-14-15-16	360	235	70
701.470EH.1	470E (ER 32; 15 St.) 3-4-5-6-7-8-9-10-11-12-14-15-16-18-20	360	235	70
701.472EH.1	472E (ER 40; 16 St.) 4-5-6-7-8-9-10-11-12-14-16-18-20-22-24-26	360	235	70



K Spannzangen mit Dichtstopfen und Kühkanalbohrungen

ISO 15488 B (DIN 6499 B) System ER

Collets with seals and cooling channels ISO 15488 B (DIN 6499 B) ER-system
 Pincettes de serrage avec canaux d'arrosage ISO 15488 B (DIN 6499 B) système ER

Spannzangensätze im Holzsockel

Collet sets in wooden sockets
 Jeux de pincettes dans socles en bois

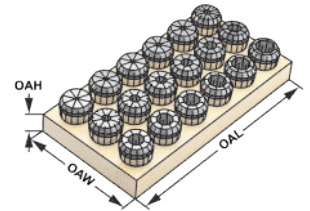

Bestell-Nr. Order no. Référence	Abmessung Size Dimension	OAL	OAW	OAH
426EC-S	426E (ER 16; 5 St.) 3-4-5-6-7	130	50	25
428EC-S	428E (ER 20; 6 St.) 4-5-6-7-8-9	165	110	25
430EC-S	430E (ER 25; 12 St.) 3-4-5-6-7-8-9-10-11-12-13-14	150	195	25
470EC-S	470E (ER 32; 15 St.) 3-4-5-6-7-8-9-10-11-12-14-15-16-18-20	190	150	30
472EC-S	472E (ER 40; 16 St.) 4-5-6-7-8-9-10-11-12-14-16-18-20-22-24-26	290	195	25

Spannzangensätze im Holzkasten

Collet sets in wooden boxes
 Jeux de pincettes dans coffrets en bois

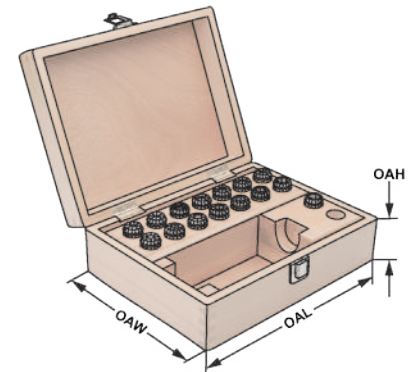

Bestell-Nr. Order no. Référence	Abmessung Size Dimension	OAL	OAW	OAH
701.426EC.1	426E (ER 16; 5 St.) 3-4-5-6-7	360	235	70
701.428EC.1	428E (ER 20; 6 St.) 4-5-6-7-8-9	360	235	70
701.430EC.1	430E (ER 25; 12 St.) 3-4-5-6-7-8-9-10-11-12-13-14	360	235	70
701.470EC.1	470E (ER 32; 15 St.) 3-4-5-6-7-8-9-10-11-12-14-15-16-18-20	360	235	70
701.472EC.1	472E (ER 40; 16 St.) 4-5-6-7-8-9-10-11-12-14-16-18-20-22-24-26	360	235	70



Collets with cooling channels along the boring ISO 15488 B (DIN 6499 B) ER-system

Pincettes de serrage avec canaux d'arrosage le long de l'alésage ISO 15488 B (DIN 6499 B) système ER

Spannzangensätze im Holzsockel

Collet sets in wooden sockets

Jeux de pincettes dans socles en bois

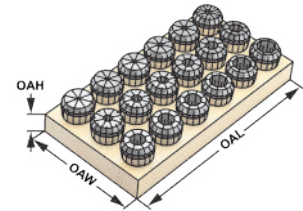

Bestell-Nr. Order no. Référence	Abmessung Size Dimension	OAL	OAW	OAH
426ECC-S	426E (ER 16; 5 St.) 3-4-5-6-7	130	50	25
428ECC-S	428E (ER 20; 6 St.) 4-5-6-7-8-9	165	110	25
430ECC-S	430E (ER 25; 12 St.) 3-4-5-6-7-8-9-10-11-12-13-14	150	195	25
470ECC-S	470E (ER 32; 15 St.) 3-4-5-6-7-8-9-10-11-12-14-15-16-18-20	190	150	30
472ECC-S	472E (ER 40; 16 St.) 4-5-6-7-8-9-10-11-12-14-16-18-20-22-24-26	290	195	25

Spannzangensätze im Holzkasten

Collet sets in wooden boxes

Jeux de pincettes dans coffrets en bois

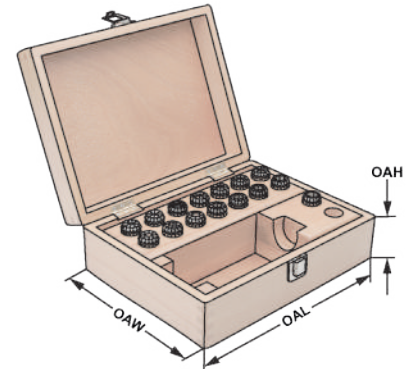

Bestell-Nr. Order no. Référence	Abmessung Size Dimension	OAL	OAW	OAH
701.426ECC.1	426E (ER 16; 5 St.) 3-4-5-6-7	360	235	70
701.428ECC.1	428E (ER 20; 6 St.) 4-5-6-7-8-9	360	235	70
701.430ECC.1	430E (ER 25; 12 St.) 3-4-5-6-7-8-9-10-11-12-13-14	360	235	70
701.470ECC.1	470E (ER 32; 15 St.) 3-4-5-6-7-8-9-10-11-12-14-15-16-18-20	360	235	70
701.472ECC.1	472E (ER 40; 16 St.) 4-5-6-7-8-9-10-11-12-14-16-18-20-22-24-26	360	235	70





Präzisionsspannzangen ISO 15488 B (DIN 6499 B) System ER - Edelstahl

Precision collets ISO 15488 B (DIN 6499 B) ER-system - stainless steel

Pinces de serrage de précision ISO 15488 B (DIN 6499 B) système ER - acier inoxydable

Spannzangensätze im Holzsockel

Collet sets in wooden sockets

Jeux de pinces dans socles en bois

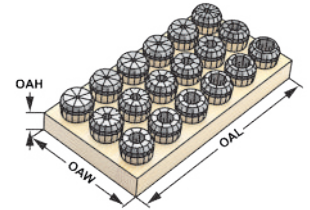

Bestell-Nr. Order no. Référence	Abmessung Size Dimension		OAL	OAW	OAH
4008ESP-S	4008E (ER 11; 5 St.)	3-4-5-6-7	130	50	25
426ESP-S	426E (ER 16; 8 St.)	3-4-5-6-7-8-9-10	165	110	25
428ESP-S	428E (ER 20; 11 St.)	3-4-5-6-7-8-9-10-11-12-13	150	195	25
430ESP-S	430E (ER 25; 14 St.)	3-4-5-6-7-8-9-10-11-12-13-14-15-16	190	150	30
470ESP-S	470E (ER 32; 18 St.)	3-4-5-6-7-8-9-10-11-12-13-14-15-16-17-18-19-20	290	195	25

Spannzangensätze im Holzkasten

Collet sets in wooden boxes

Jeux de pinces dans coffrets en bois

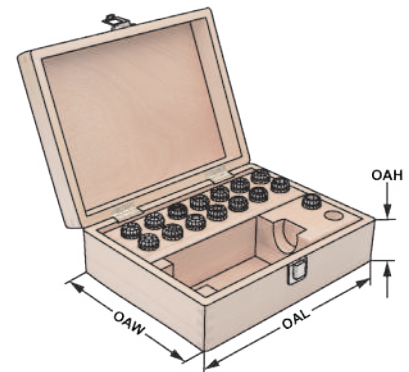

Bestell-Nr. Order no. Référence	Abmessung Size Dimension		OAL	OAW	OAH
701.4008ESP.1	4008E (ER 11; 5 St.)	3-4-5-6-7	360	235	70
701.426ESP.1	426E (ER 16; 8 St.)	3-4-5-6-7-8-9-10	360	235	70
701.428ESP.1	428E (ER 20; 11 St.)	3-4-5-6-7-8-9-10-11-12-13	360	235	70
701.430ESP.1	430E (ER 25; 14 St.)	3-4-5-6-7-8-9-10-11-12-13-14-15-16	360	235	70
701.470ESP.1	470E (ER 32; 18 St.)	3-4-5-6-7-8-9-10-11-12-13-14-15-16-17-18-19-20	360	235	70



Tap collets

Pinces de serrage pour tarauds

Spannzangensätze im Holzsockel

Collet sets in wooden sockets

Jeux de pinces dans socles en bois

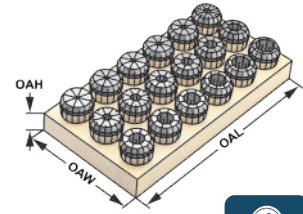
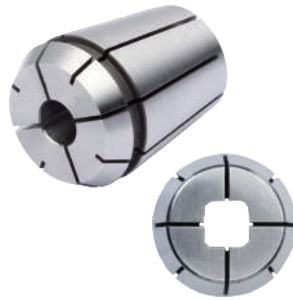

Bestell-Nr. Order no. Référence	Abmessung Size Dimension		OAL	OAW	OAH
426G-S	426E (ER 16; 6 St.)	3,5×2,7 - 4×3 - 4,5×3,4 - 6×4,9 - 7×5,5 - 8×6,2	130	50	25
428G-S	428E (ER 20; 8 St.)	3,5×2,7 - 4×3 - 4,5×3,4 - 6×4,9 - 7×5,5 - 8×6,2 - 9×7 - 10×8	165	110	25
430G-S	430E (ER 25; 10 St.)	3,5×2,7 - 4×3 - 4,5×3,4 - 6×4,9 - 7×5,5 - 8×6,2 - 9×7 - 10×8 - 11×9 - 12×9	150	195	25
470G-S	470E (ER 32; 10 St.)	4,5×3,4 - 6×4,9 - 7×5,5 - 8×6,2 - 9×7 - 10×8 - 11×9 - 12×9 - 14×11 - 16×12	190	150	30
472G-S	472E (ER 40; 11 St.)	6×4,9 - 7×5,5 - 8×6,2 - 9×7 - 10×8 - 11×9 - 12×9 - 14×11 - 16×12 - 18×14,5 - 20×16	290	195	25

Spannzangensätze im Holzkasten

Collet sets in wooden boxes

Jeux de pinces dans coffrets en bois

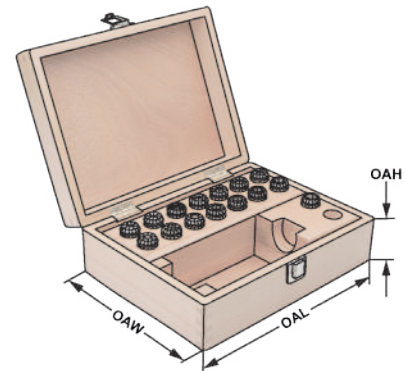
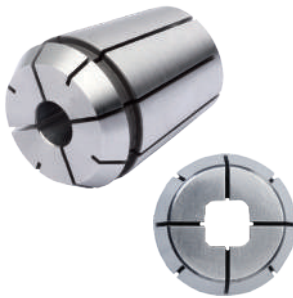

Bestell-Nr. Order no. Référence	Abmessung Size Dimension		OAL	OAW	OAH
701.426G.1	426E (ER 16; 6 St.)	3,5×2,7 - 4×3 - 4,5×3,4 - 6×4,9 - 7×5,5 - 8×6,2	360	235	70
701.428G.1	428E (ER 20; 8 St.)	3,5×2,7 - 4×3 - 4,5×3,4 - 6×4,9 - 7×5,5 - 8×6,2 - 9×7 - 10×8	360	235	70
701.430G.1	430E (ER 25; 10 St.)	3,5×2,7 - 4×3 - 4,5×3,4 - 6×4,9 - 7×5,5 - 8×6,2 - 9×7 - 10×8 - 11×9 - 12×9	360	235	70
701.470G.1	470E (ER 32; 10 St.)	4,5×3,4 - 6×4,9 - 7×5,5 - 8×6,2 - 9×7 - 10×8 - 11×9 - 12×9 - 14×11 - 16×12	360	235	70
701.472G.1	472E (ER 40; 11 St.)	6×4,9 - 7×5,5 - 8×6,2 - 9×7 - 10×8 - 11×9 - 12×9 - 14×11 - 16×12 - 18×14,5 - 20×16	360	235	70





Gewindebohrer Spannzangen mit Dichtstopfen und Kühkanalbohrungen

Tap collets with seals and cooling channels
Pincettes de serrage pour tarauds avec canaux d'arrosage

Spannzangensätze im Holzsockel Collet sets in wooden sockets Jeux de pinces dans socles en bois

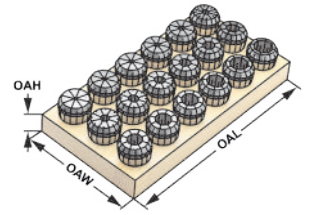
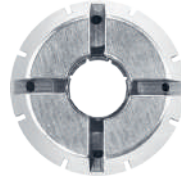

Bestell-Nr. Order no. Référence	Abmessung Size Dimension		OAL	OAW	OAH
426GC-S	426E (ER 16; 6 St.)	3,5×2,7 - 4×3 - 4,5×3,4 - 6×4,9 - 7×5,5 - 8×6,2	130	50	25
428GC-S	428E (ER 20; 8 St.)	3,5×2,7 - 4×3 - 4,5×3,4 - 6×4,9 - 7×5,5 - 8×6,2 - 9×7 - 10×8	165	110	25
430GC-S	430E (ER 25; 10 St.)	3,5×2,7 - 4×3 - 4,5×3,4 - 6×4,9 - 7×5,5 - 8×6,2 - 9×7 - 10×8 - 11×9 - 12×9	150	195	25
470GC-S	470E (ER 32; 10 St.)	4,5×3,4 - 6×4,9 - 7×5,5 - 8×6,2 - 9×7 - 10×8 - 11×9 - 12×9 - 14×11 - 16×12	190	150	30
472GC-S	472E (ER 40; 11 St.)	6×4,9 - 7×5,5 - 8×6,2 - 9×7 - 10×8 - 11×9 - 12×9 - 14×11 - 16×12 - 18×14,5 - 20×16	290	195	25

Spannzangensätze im Holzkasten Collet sets in wooden boxes Jeux de pinces dans coffrets en bois

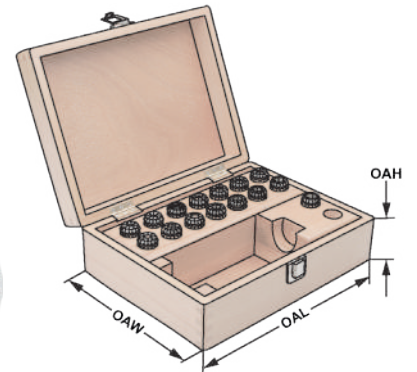

Bestell-Nr. Order no. Référence	Abmessung Size Dimension		OAL	OAW	OAH
701.426GC.1	426E (ER 16; 6 St.)	3,5×2,7 - 4×3 - 4,5×3,4 - 6×4,9 - 7×5,5 - 8×6,2	360	235	70
701.428GC.1	428E (ER 20; 8 St.)	3,5×2,7 - 4×3 - 4,5×3,4 - 6×4,9 - 7×5,5 - 8×6,2 - 9×7 - 10×8	360	235	70
701.430GC.1	430E (ER 25; 10 St.)	3,5×2,7 - 4×3 - 4,5×3,4 - 6×4,9 - 7×5,5 - 8×6,2 - 9×7 - 10×8 - 11×9 - 12×9	360	235	70
701.470GC.1	470E (ER 32; 10 St.)	4,5×3,4 - 6×4,9 - 7×5,5 - 8×6,2 - 9×7 - 10×8 - 11×9 - 12×9 - 14×11 - 16×12	360	235	70
701.472GC.1	472E (ER 40; 11 St.)	6×4,9 - 7×5,5 - 8×6,2 - 9×7 - 10×8 - 11×9 - 12×9 - 14×11 - 16×12 - 18×14,5 - 20×16	360	235	70



Tap collets with seals
Pincettes de serrage pour tarauds

Spannzangensätze im Holzsockel
Collet sets in wooden sockets
Jeux de pincettes dans socles en bois

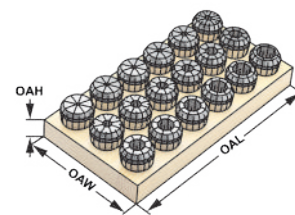

Bestell-Nr. Order no. Référence	Abmessung Size Dimension		OAL	OAW	OAH
426GA-S	426E (ER 16 6 St.)	3,5×2,7 - 4×3 - 4,5×3,4 - 6×4,9 - 7×5,5 - 8×6,2	130	50	25
428GA-S	428E (ER 20 8 St.)	3,5×2,7 - 4×3 - 4,5×3,4 - 6×4,9 - 7×5,5 - 8×6,2 - 9×7 - 10×8	165	110	25
430GA-S	430E (ER 25 10 St.)	3,5×2,7 - 4×3 - 4,5×3,4 - 6×4,9 - 7×5,5 - 8×6,2 - 9×7 - 10×8 - 11×9 - 12×9	150	195	25
470GA-S	470E (ER 32 10 St.)	4,5×3,4 - 6×4,9 - 7×5,5 - 8×6,2 - 9×7 - 10×8 - 11×9 - 12×9 - 14×11 - 16×12	190	150	30
472GA-S	472E (ER 40 11 St.)	6×4,9 - 7×5,5 - 8×6,2 - 9×7 - 10×8 - 11×9 - 12×9 - 14×11 - 16×12 - 18×14,5 - 20×16	290	195	25

Spannzangensätze im Holzkasten
Collet sets in wooden boxes
Jeux de pincettes dans coffrets en bois

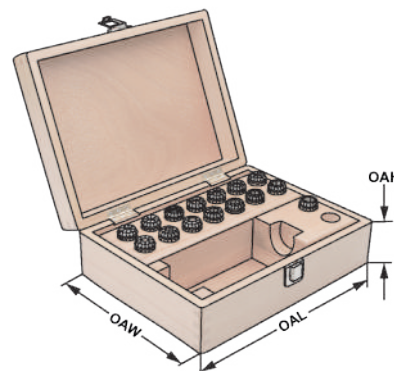

Bestell-Nr. Order no. Référence	Abmessung Size Dimension		OAL	OAW	OAH
701.426GA.1	426E (ER 16; 6 St.)	3,5×2,7 - 4×3 - 4,5×3,4 - 6×4,9 - 7×5,5 - 8×6,2	360	235	70
701.428GA.1	428E (ER 20; 8 St.)	3,5×2,7 - 4×3 - 4,5×3,4 - 6×4,9 - 7×5,5 - 8×6,2 - 9×7 - 10×8	360	235	70
701.430GA.1	430E (ER 25; 10 St.)	3,5×2,7 - 4×3 - 4,5×3,4 - 6×4,9 - 7×5,5 - 8×6,2 - 9×7 - 10×8 - 11×9 - 12×9	360	235	70
701.470GA.1	470E (ER 32; 10 St.)	4,5×3,4 - 6×4,9 - 7×5,5 - 8×6,2 - 9×7 - 10×8 - 11×9 - 12×9 - 14×11 - 16×12	360	235	70
701.472GA.1	472E (ER 40; 11 St.)	6×4,9 - 7×5,5 - 8×6,2 - 9×7 - 10×8 - 11×9 - 12×9 - 14×11 - 16×12 - 18×14,5 - 20×16	360	235	70



K Holzsockel, leer

Wooden sockets, empty
Socles en bois, vides



Verwendung:
Zur Aufbewahrung von Spannzangen.

Application:
For the storage of collets.

Application:
Pour la conservation de pinces.

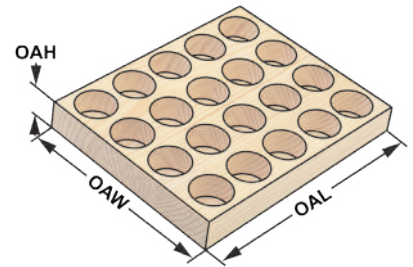

Bestell-Nr. Order no. Référence	Abmessung Size Dimension		Bohrungen Holes Trous	OAL	OAW	OAH
701.07.1	Gr. 7	ER 11	13	125	45	20
701.10.1	Gr. 10	ER 16	10	130	50	25
701.13.1	Gr. 13	ER 20	12	165	110	25
701.16.1	Gr. 16	ER 25 / OZ 16	20	190	155	30
701.20.25.1	Gr. 20 / 25	ER 32 / OZ 25	20	190	155	30
701.26.32.1	Gr. 26 / 32	ER 40 / OZ 32	30	290	240	30

Holzsockel, leer - System KPS

Wooden sockets, empty - system KPS
Socles en bois, vides - système KPS

9



Verwendung:
Zur Aufbewahrung von Spannzangen.

Application:
For the storage of collets.

Application:
Pour la conservation de pinces.

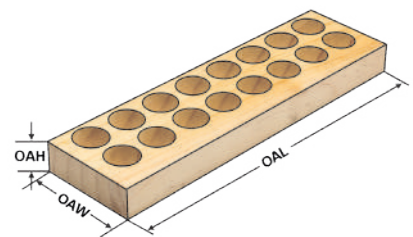

Bestell-Nr. Order no. Référence	Abmessung Size Dimension		Bohrungen Holes Trous	OAL	OAW	OAH
701.490	Gr. 10	KPS 10	10	280	35	22
701.496	Gr. 16	KPS 16	16	280	75	25

Wooden boxes, empty
Coffrets en bois, vides



Verwendung:
Zur Aufbewahrung von Spannzangenfutter, Spannschlüssel und Spannzangen.

Application:
For the storage of collet chuck, wrench and collets.

Application:
Pour la conservation de mandrin à pinces, clé de serrage et pinces.

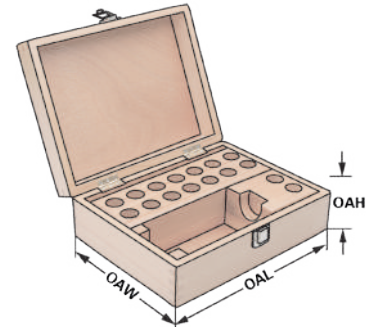

Bestell-Nr. Order no. Référence	Abmessung Size Dimension		Bohrungen Holes Trous	OAL	OAW	OAH
701.07	Gr. 7	ER 11	16	360	235	70
701.10	Gr. 10	ER 16	16	360	235	70
701.13	Gr. 13	ER 20	16	360	235	70
701.16	Gr. 16	ER 25 / OZ 16	16	360	235	70
701.20.25	Gr. 20 / 25	ER 32 / OZ 25	16	360	235	70
701.26.32	Gr. 26 / 32	ER 40 / OZ 32	16	360	235	70
701.R20	Gr. 20 mm	20 mm	16	360	235	70
701.R25	Gr. 25 mm	25 mm	12	360	235	70
701.R32	Gr. 32 mm	32 mm	12	360	235	70



Verwendung:
Zur Aufbewahrung von Gewin-
schneidfutter Schnellwechsel-Einsätzen.

Application:
For the storage of tapping quick change
adaptors.

Application:
Pour la conservation adaptateurs à
changement rapide.

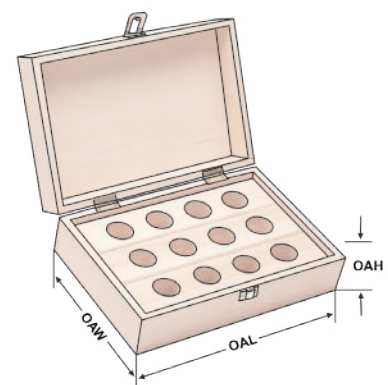

Bestell-Nr. Order no. Référence	Abmessung Size Dimension		Bohrungen Holes Trous	OAL	OAW	OAH
701.G01	Gr. 1		12	360	235	70
701.G02	Gr. 2		12	360	235	70
701.G03	Gr. 3		10	360	235	70



Verwendung:
Zur Aufnahme von Werkzeugen mit Zylinderschaft in Spannfutter System KPS. Für Anwendungen im HSC-Bereich und für hochpräzise Bearbeitungsergebnisse.

Application:
For mounting straight-shank tools in collet chucks KPS-system. To use for high speed cutting and high precision milling.

Application:
Pour le serrage d'outils avec queue cylindrique dans mandrins à pincettes système KPS. Pour l'usage dans le coupage à grande vitesse et dans l'usinage à grande précision.

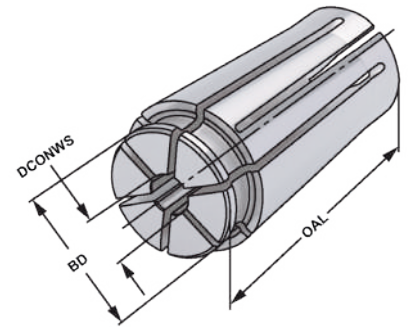

Bestell-Nr. Order no. Référence	Größe Size Taille	DCONWS	BD	OAL
490EK-010	KPS 10	1	15,5	30,5
490EK-015	KPS 10	1,5	15,5	30,5
490EK-020	KPS 10	2	15,5	30,5
490EK-025	KPS 10	2,5	15,5	30,5
490EK-030	KPS 10	3	15,5	30,5
490EK-035	KPS 10	3,5	15,5	30,5
490EK-040	KPS 10	4	15,5	30,5
490EK-045	KPS 10	4,5	15,5	30,5
490EK-050	KPS 10	5	15,5	30,5
490EK-055	KPS 10	5,5	15,5	30,5
490EK-060	KPS 10	6	15,5	30,5
490EK-065	KPS 10	6,5	15,5	30,5
490EK-070	KPS 10	7	15,5	30,5
490EK-075	KPS 10	7,5	15,5	30,5
490EK-080	KPS 10	8	15,5	30,5
490EK-085	KPS 10	8,5	15,5	30,5
490EK-090	KPS 10	9	15,5	30,5
490EK-095	KPS 10	9,5	15,5	30,5
490EK-100	KPS 10	10	15,5	30,5

9



KPS Spannzangensätze im Holzsockel

KPS collet sets in wooden sockets
KPS jeux de pincettes dans socles en bois

Bestell-Nr. Order no. Référence	Abmessung Size Dimension
490EK-S	490 EK (KPS 10 9 St.) 2-3-4-5-6-7-8-9-10



Verwendung:

Zur Aufnahme von Werkzeugen mit Zylinderschaft in Spannfutter System KPS. Für Anwendungen im HSC-Bereich und für hochpräzise Bearbeitungsergebnisse.

Application:

For mounting straight-shank tools in collet chucks KPS-system. To use for high speed cutting and high precision milling.

Application:

Pour le serrage d'outils avec queue cylindrique dans mandrins à pincettes système KPS. Pour l'usage dans le coupage à grande vitesse et dans l'usinage à grande précision.

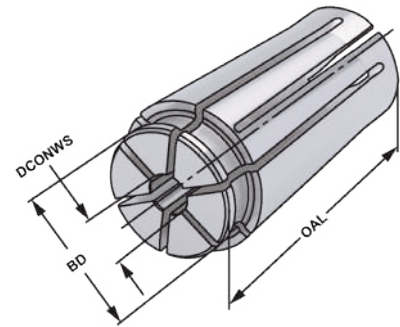

Bestell-Nr. Order no. Référence	Größe Size Taille	DCONWS	BD	OAL
496EK-040	KPS 16	4	24,6	45
496EK-045	KPS 16	4,5	24,6	45
496EK-050	KPS 16	5	24,6	45
496EK-055	KPS 16	5,5	24,6	45
496EK-060	KPS 16	6	24,6	45
496EK-065	KPS 16	6,5	24,6	45
496EK-070	KPS 16	7	24,6	45
496EK-075	KPS 16	7,5	24,6	45
496EK-080	KPS 16	8	24,6	45
496EK-085	KPS 16	8,5	24,6	45
496EK-090	KPS 16	9	24,6	45
496EK-095	KPS 16	9,5	24,6	45
496EK-100	KPS 16	10	24,6	45
496EK-105	KPS 16	10,5	24,6	45
496EK-110	KPS 16	11	24,6	45
496EK-115	KPS 16	11,5	24,6	45
496EK-120	KPS 16	12	24,6	45
496EK-125	KPS 16	12,5	24,6	45
496EK-130	KPS 16	13	24,6	45
496EK-135	KPS 16	13,5	24,6	45
496EK-140	KPS 16	14	24,6	45
496EK-145	KPS 16	14,5	24,6	45
496EK-150	KPS 16	15	24,6	45
496EK-155	KPS 16	15,5	24,6	45
496EK-160	KPS 16	16	24,6	45



KPS Spannzangensätze im Holzsockel

KPS collet sets in wooden sockets

KPS jeux de pincettes dans socles en bois

Bestell-Nr. Order no. Référence	Abmessung Size Dimension
496EK-S	496 EK (KPS 16 13 St.) 4-5-6-7-8-9-10-11-12-13-14-15-16

K Präzisionsspannzangen abgedichtet | System KPS bis 100 bar

Precision collets sealed | KPS-system up to 100 bar

Pincettes de serrage de précision étanche | Système KPS pour arrosage de haute pression 100 bar



Verwendung:

Zur Aufnahme von Werkzeugen mit Zylinderschaft in Spannfutter System KPS. Für Anwendungen im HSC-Bereich und für hochpräzise Bearbeitungsergebnisse.

Application:

For mounting straight-shank tools in collet chucks KPS-system. To use for high speed cutting and high precision milling.

Application:

Pour le serrage d'outils avec queue cylindrique dans mandrins à pincettes système KPS. Pour l'usage dans le coupage à grande vitesse et dans l'usinage à grande précision.

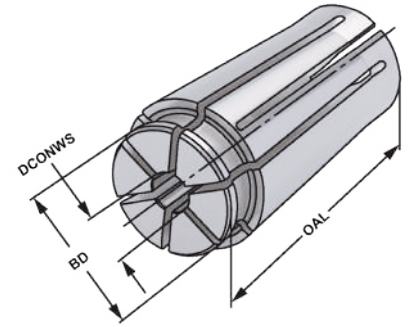

Bestell-Nr. Order no. Référence	Größe Size Taille	DCONWS	BD	OAL
490RD-030	KPS 10	3	15,5	30,5
490RD-040	KPS 10	4	15,5	30,5
490RD-050	KPS 10	5	15,5	30,5
490RD-060	KPS 10	6	15,5	30,5
490RD-070	KPS 10	7	15,5	30,5
490RD-080	KPS 10	8	15,5	30,5
490RD-090	KPS 10	9	15,5	30,5
490RD-100	KPS 10	10	15,5	30,5

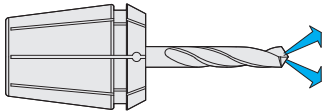

9



KPS Spannzangensätze abgedichtet im Holzsockel

KPS collet sets sealed in wooden sockets

KPS jeux de pincettes étanche dans socles en bois

Bestell-Nr. Order no. Référence	Abmessung Size Dimension
490RD-S	490 EK (KPS 10 8 St.) 3-4-5-6-7-8-9-10



Precision collets sealed | KPS-system up to 100 bar

Pincettes de serrage de précision étanche | Système KPS pour arrosage de haute pression 100 bar



Verwendung:

Zur Aufnahme von Werkzeugen mit Zylinderschaft in Spannfutter System KPS. Für Anwendungen im HSC-Bereich und für hochpräzise Bearbeitungsergebnisse.

Application:

For mounting straight-shank tools in collet chucks KPS-system. To use for high speed cutting and high precision milling.

Application:

Pour le serrage d'outils avec queue cylindrique dans mandrins à pincettes système KPS. Pour l'usage dans le coupage à grande vitesse et dans l'usinage à grande précision.

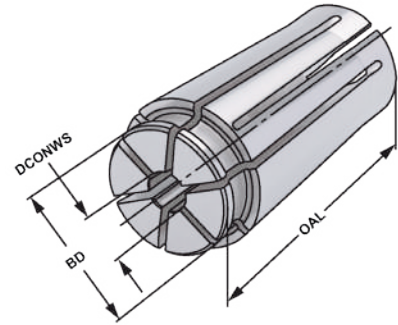

Bestell-Nr. Order no. Référence	Größe Size Taille	DCONWS	BD	OAL
496RD-040	KPS 16	4	24,6	45
496RD-050	KPS 16	5	24,6	45
496RD-060	KPS 16	6	24,6	45
496RD-070	KPS 16	7	24,6	45
496RD-080	KPS 16	8	24,6	45
496RD-090	KPS 16	9	24,6	45
496RD-100	KPS 16	10	24,6	45
496RD-110	KPS 16	11	24,6	45
496RD-120	KPS 16	12	24,6	45
496RD-130	KPS 16	13	24,6	45
496RD-140	KPS 16	14	24,6	45
496RD-150	KPS 16	15	24,6	45
496RD-160	KPS 16	16	24,6	45

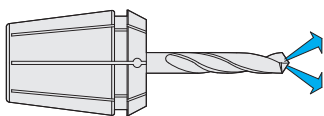

9



KPS Spannzangensätze abgedichtet im Holzsockel

KPS collet sets sealed in wooden sockets

KPS jeux de pincettes étanche dans socles en bois

Bestell-Nr. Order no. Référence	Abmessung Size Dimension
496RD-S	496 EK (KPS 16 13 St.) 4-5-6-7-8-9-10-11-12-13-14-15-16





Reduzierungen für Hochleistungs-Kraftspannfutter System HKS

für Peripheriekühlung, Bund geschlitzt, nicht kühlmitteldicht

Reduction sleeves for high performance milling chucks system HKS with peripheral cooling, collar slotted, not coolant proof

Douilles de réduction pour mandrins de serrage à haute performance HKS pour arrosage périphérique, collerette fendue, non étanche au liquide d'arrosage



Verwendung:
Zur Aufnahme von Werkzeugen mit Zylinderschaft.

Application:
For mounting straight-shank tools.

Application:
Pour le serrage d'outils avec queue cylindrique.

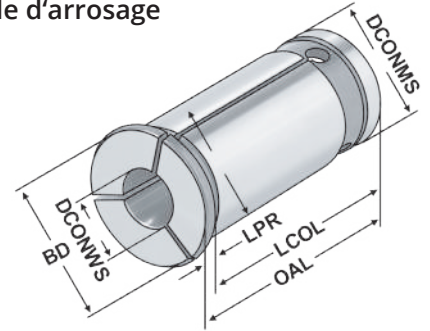

Hinweis:

Note:

Observation:

Der Spanndurchmesser ist für eine Werkzeugtoleranz h_6 ausgelegt.

The chucking diameter is configured for a tool tolerance of h_6 .

Le diamètre de serrage est conçu pour une tolérance d'outil h_6 .

Bestell-Nr. Order no. Référence	DCONMS	DCONWS	OAL	BD	LPR	LCOL
HKS20.030	20	3	53	25	3	50
HKS20.040	20	4	53	25	3	50
HKS20.050	20	5	53	25	3	50
HKS20.060	20	6	53	25	3	50
HKS20.080	20	8	53	25	3	50
HKS20.100	20	10	53	25	3	50
HKS20.120	20	12	53	25	3	50
HKS20.140	20	14	53	25	3	50
HKS20.160	20	16	53	25	3	50
HKS25.060	25	6	60	31	3	57
HKS25.080	25	8	60	31	3	57
HKS25.100	25	10	60	31	3	57
HKS25.120	25	12	60	31	3	57
HKS25.140	25	14	60	31	3	57
HKS25.160	25	16	60	31	3	57
HKS25.180	25	18	60	31	3	57
HKS25.200	25	20	60	31	3	57
HKS32.060	32	6	73	37	4	69
HKS32.080	32	8	73	37	4	69
HKS32.100	32	10	73	37	4	69
HKS32.120	32	12	73	37	4	69
HKS32.140	32	14	73	37	4	69
HKS32.160	32	16	73	37	4	69
HKS32.180	32	18	73	37	4	69
HKS32.200	32	20	73	37	4	69
HKS32.250	32	25	73	37	4	69

9



Bestell-Nr. Order no. Référence	Abmessung Size Dimension
701.HKS.20-S	Ø 20 (5 St.) 6 - 8 - 10 - 12 - 16 Nicht abgedichtet not sealed non étanche
701.HKS.25-S	Ø 25 (6 St.) 6 - 8 - 10 - 12 - 16 - 20 Nicht abgedichtet not sealed non étanche
701.HKS.32-S	Ø 32 (7 St.) 6 - 8 - 10 - 12 - 16 - 20 - 25 Nicht abgedichtet not sealed non étanche
701.HKS.RD20-S	Ø 20 (5 St.) 6 - 8 - 10 - 12 - 16 Abgedichtet sealed étanche
701.HKS.RD25-S	Ø 25 (6 St.) 6 - 8 - 10 - 12 - 16 - 20 Abgedichtet sealed étanche
701.HKS.RD32-S	Ø 32 (7 St.) 6 - 8 - 10 - 12 - 16 - 20 - 25 Abgedichtet sealed étanche

Reduction sleeves for high performance milling chucks system HKS for internal coolant supply, closed collar, coolant proof up to max. 80 bar
 Douilles de réduction pour mandrins de serrage à haute performance HKS avec arrosage centrale, collerette pleine, étanche au liquide d'arrosage jusqu'à 80 bar max.



Verwendung:
 Zur Aufnahme von Werkzeugen mit Zylinderschaft und innerer Kühlmittelzufuhr.

Application:
 For mounting straight-shank tools with internal coolant.

Application:
 Pour le serrage d'outils avec queue cylindrique et arrosage centrale.

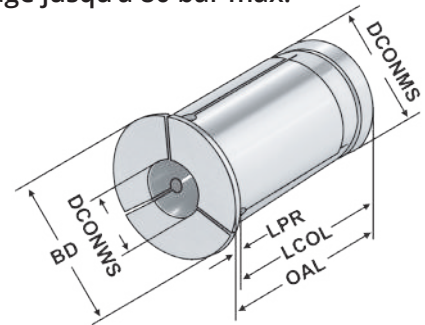

Hinweis: Der Spanndurchmesser ist für eine Werkzeugtoleranz h_6 ausgelegt.
Note: The chucking diameter is configured for a tool tolerance of h_6 .
Observation: Le diamètre de serrage est conçu pour une tolérance d'outil h_6 .

Bestell-Nr. Order no. Référence	DCONMS	DCONWS	OAL	BD	LPR	LCOL
HKS.RD20.030	20	3	52,5	28	3,5	49
HKS.RD20.040	20	4	52,5	28	3,5	49
HKS.RD20.050	20	5	52,5	28	3,5	49
HKS.RD20.060	20	6	52,5	28	3,5	49
HKS.RD20.080	20	8	52,5	28	3,5	49
HKS.RD20.100	20	10	52,5	28	3,5	49
HKS.RD20.120	20	12	52,5	28	3,5	49
HKS.RD20.140	20	14	52,5	28	3,5	49
HKS.RD20.160	20	16	52,5	28	3,5	49
HKS.RD25.030	25	3	56,5	34	2	54,5
HKS.RD25.040	25	4	56,5	34	2	54,5
HKS.RD25.050	25	5	56,5	34	2	54,5
HKS.RD25.060	25	6	56,5	34	2	54,5
HKS.RD25.080	25	8	56,5	34	2	54,5
HKS.RD25.100	25	10	56,5	34	2	54,5
HKS.RD25.120	25	12	56,5	34	2	54,5
HKS.RD25.140	25	14	56,5	34	2	54,5
HKS.RD25.160	25	16	56,5	34	2	54,5
HKS.RD25.180	25	18	56,5	34	2	54,5
HKS.RD25.200	25	20	56,5	34	2	54,5
HKS.RD32.030	32	3	62,5	42	5	57,5
HKS.RD32.040	32	4	62,5	42	5	57,5
HKS.RD32.050	32	5	62,5	42	5	57,5
HKS.RD32.060	32	6	62,5	42	5	57,5
HKS.RD32.080	32	8	62,5	42	5	57,5
HKS.RD32.100	32	10	62,5	42	5	57,5
HKS.RD32.120	32	12	62,5	42	5	57,5
HKS.RD32.140	32	14	62,5	42	5	57,5
HKS.RD32.160	32	16	62,5	42	5	57,5
HKS.RD32.180	32	18	62,5	42	5	57,5
HKS.RD32.200	32	20	62,5	42	5	57,5
HKS.RD32.250	32	25	62,5	42	5	57,5



HKS Kraftspannfutter im Holzkasten mit Reduzierungen nicht kühlmitteldicht

HKS Milling chuck in wooden box with reduction bushes, not coolant proof

HKS mandrin de serrage dans coffret en bois avec douilles de réduction, pas étanche

Bestell-Nr. Order no. Référence	Abmessung Size Dimension	Reduzierungen Reduction sleeves Douilles de réduction	Typ Size Taille
403.64.20.SR	SK 40 - 20 - 90	(HKS20 ; 5 St.) 6-8-10-12-16	Nicht abgedichtet not sealed non étanche
403.64.25.SR	SK 40 - 25 - 105	(HKS25 ; 6 St.) 6-8-10-12-16-20	Nicht abgedichtet not sealed non étanche
403.64.32.SR	SK 40 - 32 - 105	(HKS32 ; 7 St.) 6-8-10-12-16-20-25	Nicht abgedichtet not sealed non étanche
503.64.20.SR	SK 50 - 20 - 90	(HKS20 ; 5 St.) 6-8-10-12-16	Nicht abgedichtet not sealed non étanche
503.64.25.SR	SK 50 - 25 - 90	(HKS25 ; 6 St.) 6-8-10-12-16-20	Nicht abgedichtet not sealed non étanche
503.64.32.SR	SK 50 - 32 - 90	(HKS32 ; 7 St.) 6-8-10-12-16-20-25	Nicht abgedichtet not sealed non étanche
406.64.20.SR	BT 40 - 20 - 90	(HKS20 ; 5 St.) 6-8-10-12-16	Nicht abgedichtet not sealed non étanche
406.64.25.SR	BT 40 - 25 - 90	(HKS25 ; 6 St.) 6-8-10-12-16-20	Nicht abgedichtet not sealed non étanche
406.64.32.SR	BT 40 - 32 - 90	(HKS32 ; 7 St.) 6-8-10-12-16-20-25	Nicht abgedichtet not sealed non étanche
506.64.20.SR	BT 50 - 20 - 95	(HKS20 ; 5 St.) 6-8-10-12-16	Nicht abgedichtet not sealed non étanche
506.64.25.SR	BT 50 - 25 - 95	(HKS25 ; 6 St.) 6-8-10-12-16-20	Nicht abgedichtet not sealed non étanche
506.64.32.SR	BT 50 - 32 - 90	(HKS32 ; 7 St.) 6-8-10-12-16-20-25	Nicht abgedichtet not sealed non étanche
A63.64.20.SR	HSK 63 - 20 - 95	(HKS20 ; 5 St.) 6-8-10-12-16	Nicht abgedichtet not sealed non étanche
A63.64.25.SR	HSK 63 - 25 - 100	(HKS25 ; 6 St.) 6-8-10-12-16-20	Nicht abgedichtet not sealed non étanche
A63.64.32.SR	HSK 63 - 32 - 110	(HKS32 ; 7 St.) 6-8-10-12-16-20-25	Nicht abgedichtet not sealed non étanche
A100.64.20.SR	HSK 100 - 20 - 105	(HKS20 ; 5 St.) 6-8-10-12-16	Nicht abgedichtet not sealed non étanche
A100.64.25.SR	HSK 100 - 25 - 105	(HKS25 ; 6 St.) 6-8-10-12-16-20	Nicht abgedichtet not sealed non étanche
A100.64.32.SR	HSK 100 - 32 - 105	(HKS32 ; 7 St.) 6-8-10-12-16-20-25	Nicht abgedichtet not sealed non étanche



HKS Kraftspannfutter im Holzkasten mit Reduzierungen, kühlmitteldicht

HKS Milling chuck in wooden box with reduction bushes, coolant proof

HKS mandrin de serrage dans coffret en bois avec douilles de réduction, étanche

Bestell-Nr. Order no. Référence	Abmessung Size Dimension	Reduzierungen Reduction sleeves Douilles de réduction	Typ Size Taille
403.64.20.SRD	SK 40 - 20 - 90	(HKS20 RD; 5 St.) 6-8-10-12-16	Abgedichtet sealed étanche
403.64.25.SRD	SK 40 - 25 - 105	(HKS25 RD; 6 St.) 6-8-10-12-16-20	Abgedichtet sealed étanche
403.64.32.SRD	SK 40 - 32 - 105	(HKS32 RD; 7 St.) 6-8-10-12-16-20-25	Abgedichtet sealed étanche
503.64.20.SRD	SK 50 - 20 - 90	(HKS20 RD; 5 St.) 6-8-10-12-16	Abgedichtet sealed étanche
503.64.25.SRD	SK 50 - 25 - 90	(HKS25 RD; 6 St.) 6-8-10-12-16-20	Abgedichtet sealed étanche
503.64.32.SRD	SK 50 - 32 - 90	(HKS32 RD; 7 St.) 6-8-10-12-16-20-25	Abgedichtet sealed étanche
406.64.20.SRD	BT 40 - 20 - 90	(HKS20 RD; 5 St.) 6-8-10-12-16	Abgedichtet sealed étanche
406.64.25.SRD	BT 40 - 25 - 90	(HKS25 RD; 6 St.) 6-8-10-12-16-20	Abgedichtet sealed étanche
406.64.32.SRD	BT 40 - 32 - 90	(HKS32 RD; 7 St.) 6-8-10-12-16-20-25	Abgedichtet sealed étanche
506.64.20.SRD	BT 50 - 20 - 95	(HKS20 RD; 5 St.) 6-8-10-12-16	Abgedichtet sealed étanche
506.64.25.SRD	BT 50 - 25 - 95	(HKS25 RD; 6 St.) 6-8-10-12-16-20	Abgedichtet sealed étanche
506.64.32.SRD	BT 50 - 32 - 90	(HKS32 RD; 7 St.) 6-8-10-12-16-20-25	Abgedichtet sealed étanche
A63.64.20.SRD	HSK 63 - 20 - 95	(HKS20 RD; 5 St.) 6-8-10-12-16	Abgedichtet sealed étanche
A63.64.25.SRD	HSK 63 - 25 - 100	(HKS25 RD; 6 St.) 6-8-10-12-16-20	Abgedichtet sealed étanche
A63.64.32.SRD	HSK 63 - 32 - 110	(HKS32 RD; 7 St.) 6-8-10-12-16-20-25	Abgedichtet sealed étanche
A100.64.20.SRD	HSK 100 - 20 - 105	(HKS20 RD; 5 St.) 6-8-10-12-16	Abgedichtet sealed étanche
A100.64.25.SRD	HSK 100 - 25 - 105	(HKS25 RD; 6 St.) 6-8-10-12-16-20	Abgedichtet sealed étanche
A100.64.32.SRD	HSK 100 - 32 - 105	(HKS32 RD; 7 St.) 6-8-10-12-16-20-25	Abgedichtet sealed étanche

K Reduzierungen für Hydrodehnspannfutter

für Peripheriekühlung, Bund geschlitzt, nicht kühlmitteldicht

Reduction sleeves for hydraulic expansion chucks with peripheral cooling, collar slotted, not coolant proof
 Douilles de réduction pour mandrins expansibles hydrauliques pour arrosage périphérique, collerette fendue, non étanche au liquide d'arrosage



Verwendung:
 Zur Aufnahme von Werkzeugen mit Zylinderschaft.

Application:
 For mounting straight-shank tools.

Application:
 Pour le serrage d'outils avec queue cylindrique.

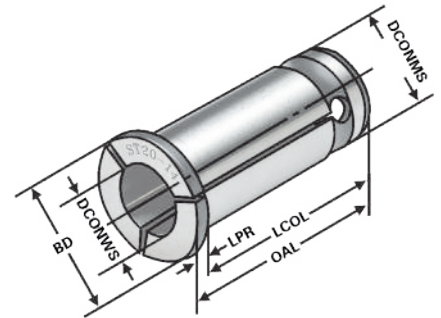

Bestell-Nr. Order no. Référence	DCONMS	DCONWS	OAL	BD	LPR	LCOL
R20.030	20	3	53	25	3	50
R20.040	20	4	53	25	3	50
R20.050	20	5	53	25	3	50
R20.060	20	6	53	25	3	50
R20.080	20	8	53	25	3	50
R20.100	20	10	53	25	3	50
R20.120	20	12	53	25	3	50
R20.140	20	14	53	25	3	50
R20.160	20	16	53	25	3	50
R25.030	25	3	60	31	3	57
R25.040	25	4	60	31	3	57
R25.050	25	5	60	31	3	57
R25.060	25	6	60	31	3	57
R25.080	25	8	60	31	3	57
R25.100	25	10	60	31	3	57
R25.120	25	12	60	31	3	57
R25.140	25	14	60	31	3	57
R25.160	25	16	60	31	3	57
R25.180	25	18	60	31	3	57
R25.200	25	20	60	31	3	57
R32.060	32	6	64,6	37,5	5	59,6
R32.080	32	8	64,6	37,5	5	59,6
R32.100	32	10	64,6	37,5	5	59,6
R32.120	32	12	64,6	37,5	5	59,6
R32.140	32	14	64,6	37,5	5	59,6
R32.160	32	16	64,6	37,5	5	59,6
R32.180	32	18	64,6	37,5	5	59,6
R32.200	32	20	64,6	37,5	5	59,6
R32.250	32	25	64,6	37,5	5	59,6

Hinweis: Der Spanndurchmesser ist für eine Werkzeugtoleranz h_6 ausgelegt.
Note: The chucking diameter is configured for a tool tolerance of h_6 .
Observation: Le diamètre de serrage est conçu pour une tolérance d'outil h_6 .

für innere Kühlmittelzufuhr, Bund geschlossen, kühlmitteldicht bis max. 80 bar

Reduction sleeves for hydraulic expansion chucks for internal coolant supply, closed collar, coolant proof up to max. 80 bar

Douilles de réduction pour mandrins expansibles hydrauliques

avec arrosage centrale, collerette pleine, étanche au liquide d'arrosage jusqu'à 80 bar max.



Verwendung:

Zur Aufnahme von Werkzeugen mit Zylinderschaft und innerer Kühlmittelzufuhr.

Application:

For mounting straight-shank tools with internal coolant.

Application:

Pour le serrage d'outils avec queue cylindrique et arrosage centrale.

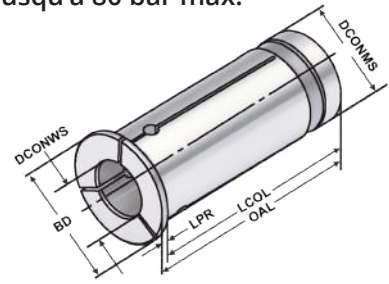

Hinweis:

Note:

Observation:

Der Spanndurchmesser ist für eine Werkzeugtoleranz h_6 ausgelegt.

The chucking diameter is configured for a tool tolerance of h_6 .

Le diamètre de serrage est conçu pour une tolérance d'outil h_6 .

Bestell-Nr. Order no. Référence	DCONMS	DCONWS	OAL	BD	LPR	LCOL
RD12.030	12	3	40	16	2	38
RD12.040	12	4	40	16	2	38
RD12.050	12	5	40	16	2	38
RD12.060	12	6	40	16	2	38
RD12.080	12	8	40	16	2	38
RD20.030	20	3	52,9	25	3,5	49,4
RD20.040	20	4	52,9	25	3,5	49,4
RD20.050	20	5	52,9	25	3,5	49,4
RD20.060	20	6	52,9	25	3,5	49,4
RD20.080	20	8	52,9	25	3,5	49,4
RD20.100	20	10	52,9	25	3,5	49,4
RD20.120	20	12	52,9	25	3,5	49,4
RD20.140	20	14	52,9	25	3,5	49,4
RD20.160	20	16	52,9	25	3,5	49,4
RD25.030	25	3	52,5	30,5	2	50,5
RD25.040	25	4	52,5	30,5	2	50,5
RD25.050	25	5	52,5	30,5	2	50,5
RD25.060	25	6	52,5	30,5	2	50,5
RD25.080	25	8	52,5	30,5	2	50,5
RD25.100	25	10	52,5	30,5	2	50,5
RD25.120	25	12	52,5	30,5	2	50,5
RD25.140	25	14	52,5	30,5	2	50,5
RD25.160	25	16	52,5	30,5	2	50,5
RD25.180	25	18	52,5	30,5	2	50,5
RD25.200	25	20	52,5	30,5	2	50,5
RD32.030	32	3	66	37,5	5	61
RD32.040	32	4	66	37,5	5	61
RD32.050	32	5	66	37,5	5	61
RD32.060	32	6	66	37,5	5	61
RD32.080	32	8	66	37,5	5	61
RD32.100	32	10	66	37,5	5	61
RD32.120	32	12	66	37,5	5	61
RD32.140	32	14	66	37,5	5	61
RD32.160	32	16	66	37,5	5	61
RD32.180	32	18	66	37,5	5	61
RD32.200	32	20	66	37,5	5	61
RD32.250	32	25	66	37,5	5	61

K Reduzierungen für Hydrodehnspannfutter mit Kühlkanälen entlang der Bohrung

Reduction sleeves for hydraulic expansion chucks with cooling channels along the boring
Douilles de réduction pour mandrins expansibles hydrauliques avec canaux d'arrosage le long de l'alsage



Verwendung:
Zur Aufnahme von Werkzeugen mit Zylinderschaft.

Application:
For mounting straight-shank tools.

Application:
Pour le serrage d'outils avec queue cylindrique.

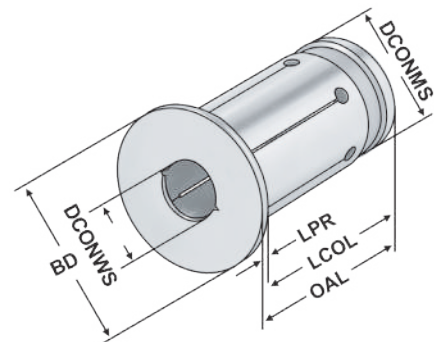

Bestell-Nr. Order no. Référence	DCONMS	DCONWS	OAL	BD	LPR	LCOL
RDC20.030	20	3	52,5	28	3,5	49
RDC20.040	20	4	52,5	28	3,5	49
RDC20.050	20	5	52,5	28	3,5	49
RDC20.060	20	6	52,5	28	3,5	49
RDC20.080	20	8	52,5	28	3,5	49
RDC20.100	20	10	52,5	28	3,5	49
RDC20.120	20	12	52,5	28	3,5	49
RDC20.140	20	14	52,5	28	3,5	49
RDC20.160	20	16	52,5	28	3,5	49
RDC25.030	25	3	56,5	34	2	54,5
RDC25.040	25	4	56,5	34	2	54,5
RDC25.050	25	5	56,5	34	2	54,5
RDC25.060	25	6	56,5	34	2	54,5
RDC25.080	25	8	56,5	34	2	54,5
RDC25.100	25	10	56,5	34	2	54,5
RDC25.120	25	12	56,5	34	2	54,5
RDC25.140	25	14	56,5	34	2	54,5
RDC25.160	25	16	56,5	34	2	54,5
RDC25.180	25	18	56,5	34	2	54,5
RDC25.200	25	20	56,5	34	2	54,5
RDC32.250	25	25	56,5	34	2	54,5
RDC32.040	32	4	62,5	42	5	57,5
RDC32.050	32	5	62,5	42	5	57,5
RDC32.060	32	6	62,5	42	5	57,5
RDC32.080	32	8	62,5	42	5	57,5
RDC32.100	32	10	62,5	42	5	57,5
RDC32.120	32	12	62,5	42	5	57,5
RDC32.140	32	14	62,5	42	5	57,5
RDC32.160	32	16	62,5	42	5	57,5
RDC32.180	32	18	62,5	42	5	57,5
RDC32.200	32	20	62,5	42	5	57,5
RDC32.250	32	25	62,5	42	5	57,5

Hinweis: Der Spanndurchmesser ist für eine Werkzeugtoleranz h_6 ausgelegt.
Note: The chucking diameter is configured for a tool tolerance of h_6 .
Observation: Le diamètre de serrage est conçu pour une tolérance d'outil h_6 .

Reduction sleeves for hydraulic expansion chucks

Douilles de réduction pour mandrins expansibles hydrauliques

$\nearrow \leq 0,005$



Spannzangensätze im Holzkasten
Collet sets in wooden boxes
Jeux de pinces dans coffrets en bois

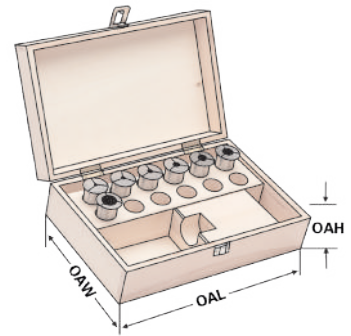

Reduzierungen, nicht abgedichtet, für Hydrodehnspannfutter im Holzkasten

Reduction sleeves, not coolant proof, for hydraulic chucks in wooden case

Douilles de réduction, non étanche, pour mandrins hydraulique dans coffrets en bois

Bestell-Nr. Order no. Référence	Abmessung Size Dimension	OAL	OAW	OAH
701.R20-S	Ø 20 (5 St.) 6 - 8 - 10 - 12 - 16	360	235	70
701.R25-S	Ø 25 (6 St.) 6 - 8 - 10 - 12 - 16 - 20	360	235	70
701.R32-S	Ø 32 (7 St.) 6 - 8 - 10 - 12 - 16 - 20 - 25	360	235	70



Reduzierungen, abgedichtet, für Hydrodehnspannfutter im Holzkasten

Reduction sleeves, coolant proof, for hydraulic chucks in wooden case

Douilles de réduction, étanche, pour mandrins hydraulique dans coffrets en bois

Bestell-Nr. Order no. Référence	Abmessung Size Dimension	OAL	OAW	OAH
701.RD20-S	Ø 20 (5 St.) 6 - 8 - 10 - 12 - 16	360	235	70
701.RD25-S	Ø 25 (6 St.) 6 - 8 - 10 - 12 - 16 - 20	360	235	70
701.RD32-S	Ø 32 (7 St.) 6 - 8 - 10 - 12 - 16 - 20 - 25	360	235	70

9



Reduzierungen, abgedichtet mit Kühlkanälen, für Hydrodehnspannfutter im Holzkasten

Reduction sleeves, coolant proof with cooling channels, for hydraulic chucks in wooden case

Douilles de réduction, étanche avec canaux d'arrosage, pour mandrins hydraulique dans coffret en bois

Bestell-Nr. Order no. Référence	Abmessung Size Dimension	OAL	OAW	OAH
701.RDC20-S	Ø 20 (5 St.) 6 - 8 - 10 - 12 - 16	360	235	70
701.RDC25-S	Ø 25 (6 St.) 6 - 8 - 10 - 12 - 16 - 20	360	235	70
701.RDC32-S	Ø 32 (7 St.) 6 - 8 - 10 - 12 - 16 - 20 - 25	360	235	70



Hydro-Dehnspannfutter DIN ISO 7388-1 (ehemals DIN 69871) im Holzkasten

Hydraulic expansion chucks in wooden box DIN ISO 7388-1 (formerly DIN 69871)

Mandrins expansibles hydrauliques dans coffret en bois DIN ISO 7388-1 (l'ancien DIN 69871)



Bestell-Nr. Order no. Référence	Abmessung Size Dimension	Reduzierungen Reduction sleeves Douilles de réduction	Typ Size Taille
302.H20.R.S	SK 30 - 20 - 90	6 - 8 - 10 - 12 - 16	Nicht abgedichtet not sealed non étanche
403.H20.R.S	SK 40 - 20 - 82	6 - 8 - 10 - 12 - 16	Nicht abgedichtet not sealed non étanche
403.H25.R.S	SK 40 - 25 - 117	6 - 8 - 10 - 12 - 16 - 20	Nicht abgedichtet not sealed non étanche
403.H32.R.S	SK 40 - 32 - 117	6 - 8 - 10 - 12 - 16 - 20 - 25	Nicht abgedichtet not sealed non étanche
503.H20.R.S	SK 50 - 20 - 82	6 - 8 - 10 - 12 - 16	Nicht abgedichtet not sealed non étanche
503.H25.R.S	SK 50 - 25 - 87	6 - 8 - 10 - 12 - 16 - 20	Nicht abgedichtet not sealed non étanche
503.H32.R.S	SK 50 - 32 - 91	6 - 8 - 10 - 12 - 16 - 20 - 25	Nicht abgedichtet not sealed non étanche

Bestell-Nr. Order no. Référence	Abmessung Size Dimension	Reduzierungen Reduction sleeves Douilles de réduction	Typ Size Taille
302.H20.RD.S	SK 30 - 20 - 90	6 - 8 - 10 - 12 - 16	Abgedichtet sealed étanche
403.H20.RD.S	SK 40 - 20 - 82	6 - 8 - 10 - 12 - 16	Abgedichtet sealed étanche
403.H25.RD.S	SK 40 - 25 - 117	6 - 8 - 10 - 12 - 16 - 20	Abgedichtet sealed étanche
403.H32.RD.S	SK 40 - 32 - 117	6 - 8 - 10 - 12 - 16 - 20 - 25	Abgedichtet sealed étanche
503.H20.RD.S	SK 50 - 20 - 82	6 - 8 - 10 - 12 - 16	Abgedichtet sealed étanche
503.H25.RD.S	SK 50 - 25 - 87	6 - 8 - 10 - 12 - 16 - 20	Abgedichtet sealed étanche
503.H32.RD.S	SK 50 - 32 - 91	6 - 8 - 10 - 12 - 16 - 20 - 25	Abgedichtet sealed étanche

Bestell-Nr. Order no. Référence	Abmessung Size Dimension	Reduzierungen Reduction sleeves Douilles de réduction	Typ Size Taille
302.H20.RDC.S	SK 30 - 20 - 90	6 - 8 - 10 - 12 - 16	Abgedichtet + KK sealed + CC étanche + CA
403.H20.RDC.S	SK 40 - 20 - 82	6 - 8 - 10 - 12 - 16	Abgedichtet + KK sealed + CC étanche + CA
403.H25.RDC.S	SK 40 - 25 - 117	6 - 8 - 10 - 12 - 16 - 20	Abgedichtet + KK sealed + CC étanche + CA
403.H32.RDC.S	SK 40 - 32 - 117	6 - 8 - 10 - 12 - 16 - 20 - 25	Abgedichtet + KK sealed + CC étanche + CA
503.H20.RDC.S	SK 50 - 20 - 82	6 - 8 - 10 - 12 - 16	Abgedichtet + KK sealed + CC étanche + CA
503.H25.RDC.S	SK 50 - 25 - 87	6 - 8 - 10 - 12 - 16 - 20	Abgedichtet + KK sealed + CC étanche + CA
503.H32.RDC.S	SK 50 - 32 - 91	6 - 8 - 10 - 12 - 16 - 20 - 25	Abgedichtet + KK sealed + CC étanche + CA

Hydro-Dehnspannfutter DIN ISO 7388-2 (ehemals JIS B 6339 MAS-BT)



Hydraulic expansion chucks in wooden box DIN ISO 7388-2 (formerly JIS B 6339 MAS-BT)

Mandrins expansibles hydrauliques dans coffret en bois DIN ISO 7388-2 (l'ancien JIS B 6339 MAS-BT)



Bestell-Nr. Order no. Référence	Abmessung Size Dimension	Reduzierungen Reduction sleeves Douilles de réduction	Typ Size Taille
305.H20.R.S	BT 30 - 20 - 90	6 - 8 - 10 - 12 - 16	Nicht abgedichtet not sealed non étanche
406.H20.R.S	BT 40 - 20 - 90	6 - 8 - 10 - 12 - 16	Nicht abgedichtet not sealed non étanche
406.H25.R.S	BT 40 - 25 - 90	6 - 8 - 10 - 12 - 16 - 20	Nicht abgedichtet not sealed non étanche
406.H32.R.S	BT 40 - 32 - 110	6 - 8 - 10 - 12 - 16 - 20 - 25	Nicht abgedichtet not sealed non étanche
506.H20.R.S	BT 50 - 20 - 110	6 - 8 - 10 - 12 - 16	Nicht abgedichtet not sealed non étanche
506.H25.R.S	BT 50 - 25 - 110	6 - 8 - 10 - 12 - 16 - 20	Nicht abgedichtet not sealed non étanche
506.H32.R.S	BT 50 - 32 - 110	6 - 8 - 10 - 12 - 16 - 20 - 25	Nicht abgedichtet not sealed non étanche

Bestell-Nr. Order no. Référence	Abmessung Size Dimension	Reduzierungen Reduction sleeves Douilles de réduction	Typ Size Taille
305.H20.RD.S	BT 30 - 20 - 90	6 - 8 - 10 - 12 - 16	Abgedichtet sealed étanche
406.H20.RD.S	BT 40 - 20 - 90	6 - 8 - 10 - 12 - 16	Abgedichtet sealed étanche
406.H25.RD.S	BT 40 - 25 - 90	6 - 8 - 10 - 12 - 16 - 20	Abgedichtet sealed étanche
406.H32.RD.S	BT 40 - 32 - 110	6 - 8 - 10 - 12 - 16 - 20 - 25	Abgedichtet sealed étanche
506.H20.RD.S	BT 50 - 20 - 110	6 - 8 - 10 - 12 - 16	Abgedichtet sealed étanche
506.H25.RD.S	BT 50 - 25 - 110	6 - 8 - 10 - 12 - 16 - 20	Abgedichtet sealed étanche
506.H32.RD.S	BT 50 - 32 - 110	6 - 8 - 10 - 12 - 16 - 20 - 25	Abgedichtet sealed étanche

Bestell-Nr. Order no. Référence	Abmessung Size Dimension	Reduzierungen Reduction sleeves Douilles de réduction	Typ Size Taille
305.H20.RDC.S	BT 30 - 20 - 90	6 - 8 - 10 - 12 - 16	Abgedichtet + KK sealed + CC étanche + CA
406.H20.RDC.S	BT 40 - 20 - 90	6 - 8 - 10 - 12 - 16	Abgedichtet + KK sealed + CC étanche + CA
406.H25.RDC.S	BT 40 - 25 - 90	6 - 8 - 10 - 12 - 16 - 20	Abgedichtet + KK sealed + CC étanche + CA
406.H32.RDC.S	BT 40 - 32 - 110	6 - 8 - 10 - 12 - 16 - 20 - 25	Abgedichtet + KK sealed + CC étanche + CA
506.H20.RDC.S	BT 50 - 20 - 110	6 - 8 - 10 - 12 - 16	Abgedichtet + KK sealed + CC étanche + CA
506.H25.RDC.S	BT 50 - 25 - 110	6 - 8 - 10 - 12 - 16 - 20	Abgedichtet + KK sealed + CC étanche + CA
506.H32.RDC.S	BT 50 - 32 - 110	6 - 8 - 10 - 12 - 16 - 20 - 25	Abgedichtet + KK sealed + CC étanche + CA



Hydro-Dehnspannfutter DIN 69893 / ISO 12164 (HSK-A) im Holzkasten

Hydraulic expansion chucks in wooden box DIN 69893 / ISO 12164 (HSK-A)

Mandrins expansibles hydrauliques dans coffret en bois DIN 69893 / ISO 12164 (HSK-A)



Bestell-Nr. Order no. Référence	Abmessung Size Dimension	Reduzierungen Reduction sleeves Douilles de réduction	Typ Size Taille
A63.H20.R.S	HSK 63 - 20 - 100	6 - 8 - 10 - 12 - 16	Nicht abgedichtet not sealed non étanche
A63.H25.R.S	HSK 63 - 25 - 120	6 - 8 - 10 - 12 - 16 - 20	Nicht abgedichtet not sealed non étanche
A63.H32.R.S	HSK 63 - 32 - 125	6 - 8 - 10 - 12 - 16 - 20 - 25	Nicht abgedichtet not sealed non étanche
A100.H20.R.S	HSK 100 - 20 - 105	6 - 8 - 10 - 12 - 16	Nicht abgedichtet not sealed non étanche
A100.H25.R.S	HSK 100 - 25 - 115	6 - 8 - 10 - 12 - 16 - 20	Nicht abgedichtet not sealed non étanche
A100.H32.R.S	HSK 100 - 20 - 120	6 - 8 - 10 - 12 - 16 - 20 - 25	Nicht abgedichtet not sealed non étanche

Bestell-Nr. Order no. Référence	Abmessung Size Dimension	Reduzierungen Reduction sleeves Douilles de réduction	Typ Size Taille
A63.H20.RD.S	HSK 63 - 20 - 100	6 - 8 - 10 - 12 - 16	Abgedichtet sealed étanche
A63.H25.RD.S	HSK 63 - 25 - 120	6 - 8 - 10 - 12 - 16 - 20	Abgedichtet sealed étanche
A63.H32.RD.S	HSK 63 - 32 - 125	6 - 8 - 10 - 12 - 16 - 20 - 25	Abgedichtet sealed étanche
A100.H20.RD.S	HSK 100 - 20 - 105	6 - 8 - 10 - 12 - 16	Abgedichtet sealed étanche
A100.H25.RD.S	HSK 100 - 25 - 115	6 - 8 - 10 - 12 - 16 - 20	Abgedichtet sealed étanche
A100.H32.RD.S	HSK 100 - 20 - 120	6 - 8 - 10 - 12 - 16 - 20 - 25	Abgedichtet sealed étanche

Bestell-Nr. Order no. Référence	Abmessung Size Dimension	Reduzierungen Reduction sleeves Douilles de réduction	Typ Size Taille
A63.H20.RDC.S	HSK 63-20-100	6-8-10-12-16	Abgedichtet + KK sealed + CC étanche + CA
A63.H25.RDC.S	HSK 63-25-120	6-8-10-12-16-20	Abgedichtet + KK sealed + CC étanche + CA
A63.H32.RDC.S	HSK 63-32-125	6-8-10-12-16-20-25	Abgedichtet + KK sealed + CC étanche + CA
A100.H20.RDC.S	HSK 100-20-105	6-8-10-12-16	Abgedichtet + KK sealed + CC étanche + CA
A100.H25.RDC.S	HSK 100-25-115	6-8-10-12-16-20	Abgedichtet + KK sealed + CC étanche + CA
A100.H32.RDC.S	HSK 100-20-120	6-8-10-12-16-20-25	Abgedichtet + KK sealed + CC étanche + CA

Reparatur und Wartung für Hydro-Dehnspannfutter

Die Hydro-Dehnspanntechnik ist eine weltweit verbreitete, bewährte und zuverlässige Methode zur Aufnahme von Werkzeugen. Dank ihrer konstruktiven Vorteile ist sie unempfindlich, wartungsarm und langlebig. Dennoch kommt es durch thermische und mechanische Belastung im Werkstattgebrauch im Laufe der Zeit zu Spannkraftverlusten. Die Folge sind schlechtere Werkzeugstandzeiten und Qualitätseinbußen bei der Bearbeitung bis hin zum teuren Werkzeugbruch.

Wir warten und reparieren Ihre Hydro-Dehnspannfutter - egal ob von uns oder ein Fremdfabrikat - kostengünstig hier bei uns in Süd-Deutschland.

Hier prüfen wir die Ursachen für den Spannkraftverlust und reparieren innerhalb von zwei Wochen zu einem günstigen Festpreis. Wir erneuern dabei alle Verschleißteile, befüllen das Hydrauliksystem neu und justieren das Hydrauliksystem auf den korrekten Spanndruck. Abschließend erfolgt eine Endprüfung.

Kontaktieren Sie unseren Kundenservice für weitere Informationen und Preise.

Maintenance and repair of hydraulic chucks

Clamping of tools with hydraulic chucks is a widespread, well-established and reliable method.

It is a resistant, easy-to-operate and durable way of clamping due to its advantageous construction design.

Nevertheless in the course of time under the influence of thermal and mechanical outputs at factories loss of clamping force is observed. As a result the life of the tool shortens and its quality during the working process reduces. Therefore it leads to a costly damage of the tool.

We maintain and repair your hydraulic chucks - both those manufactured at our place and those produced somewhere else - for a reasonable price here at our office in the south of Germany.

We check possible causes of the clamping force reduction and repair it within two weeks at a fixed low price. At the same time we renew all the fast wearing parts, fill the hydraulic system anew and adjust its clamping force. Afterwards the final inspection stage takes place.

You are welcome to contact our customer service for further information and prices.

La réparation et la maintenance des mandrins hydrauliques

L'accueil des outils à l'aide d'un mandrin hydraulique est une technique éprouvée, répandue à l'échelle mondiale et de confiance. Grâce à sa construction avantageuse elle est robuste, facile à entretenir et durable.

Pourtant à cause de la charge thermique et mécanique imposés sur les mandrins lors du travail la tension du ressort diminue au fil du temps. Par conséquent la résistance des outils coupants se détériore et la qualité lors d'usinage se réduit. En retour cela conduit à la rupture coûteuse d'outil.

On entretient et répare vos mandrins hydrauliques - peu importe l'issue de notre production ou d'ailleurs - bon marché et ici chez nous au sud de l'Allemagne.

Tout d'abord nos spécialistes cherchent la cause de la perte de la tension du ressort, ensuite ils effectuent la réparation sous 2 semaines pour le prix fixe et favorable. En outre ils renouvellent toutes les pièces d'usure, remplissent le système hydraulique à nouveau et ajustent la tension correcte. À la fin l'inspection finale se déroule.

Contactez notre centre de service client pour obtenir l'information supplémentaire ainsi que l'information actuelle sur le prix.



ZUBEHÖR
ACCESSORIES
ACCESSOIRES

ZUBEHÖR

ACCESSORIES

ACCESSOIRES



10.04  KPS	10.06  HKS	10.08 	10.09 
10.10 	10.18 	10.20 	10.22 
10.23 	10.26 	10.30 	10.36 
10.40 	10.42 	10.48 	10.50 
10.51 	10.52 	10.58 	10.59 
10.60 	10.62 	10.63 	10.64 
10.66 	10.68 	10.69 	10.72 
10.73 	10.74 	10.75 	10.76 

Index
Sommaire

10.78	10.79	10.80	10.82
10.83	10.84	10.85	10.87
10.88	10.89	10.90	10.92
10.94	10.95	10.96	10.97
10.98	10.99	10.100	10.101
10.102	10.104	10.108	10.112
10.118	10.119	10.126	

K Spannmuttern | System KPS

Clamping nuts | KPS-system
Ecrous de serrage | Système KPS



Verwendung:
Für Spannzangen System KPS.
Application:
For collets KPS-system.
Application:
Pour pinces de serrage système KPS.

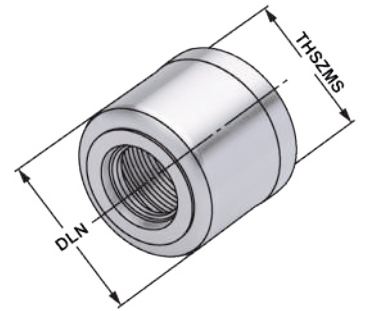

Bestell-Nr. Order no. Référence	Ausführung Version Type	DCONWS	DLN	HLN	TQX	THSZMS
490EK-181	490EK KPS 10	1 - 10	27,15	24	40	M21,5 × 1,0
496EK-181	496EK KPS 16	4 - 16	40	31	70	M32,0 × 1,5

Montagehilfe | System KPS

Collet extractor | KPS-system
Moyen d'assemblage | Système KPS



Verwendung:
Zur Montage und Demontage der Spannzangen System KPS.
Application:
For the assembly and disassembly of collets KPS-system.
Application:
Pour l'assemblage et désassemblage de pinces de de serrage système KPS.

Bestell-Nr. Order no. Référence	Abmessung Size Dimension
490EK-183	490EK KPS 10
496EK-183	496EK KPS 16

10

Einstellschraube für innere Kühlmittelzufuhr System KPS

Setting screw for for internal cooling KPS-system
Vis de réglage pour l`arrosage centrale pour système KPS



Verwendung:
Zur Abdichtung von Werkzeugen mit Innenkühlung.
Application:
For sealing tools with internal cooling.
Application:
Pour assurer l'étanchéité en cas d'utilisation d'outils avec lubrification interne.

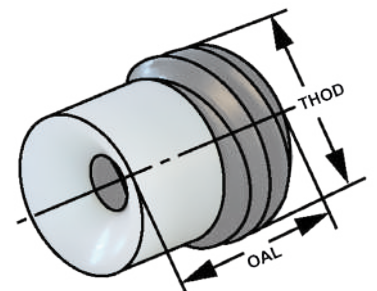

Bestell-Nr. Order no. Référence	Abmessung Size Dimension	OAL	THOD
490EK-184	490EK KPS 10	12,5	M12 x 1,75
496EK-184	496EK KPS 16	16,3	M18 x 1,50

Wrenches for clamping nuts | KPS-system

Clés de serrage pour écrous de serrage | Système KPS



Verwendung:
Für Spannmuttern System KPS.
Application:
For clamping nuts KPS-system.
Application:
Pour écrous de serrage système KPS.

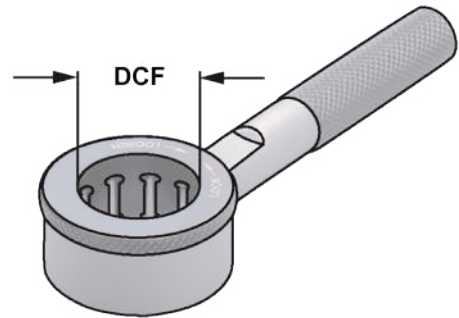

Bestell-Nr. Order no. Référence	Abmessung Size Dimension	DCF
490EK-182	490EK KPS 10	28
496EK-182	496EK KPS 16	40

Rollenschlüssel-Einsteckwerkzeug für System KPS

Roller Bearing plug-in head for KPS-system

Embout pour clés à rouleaux pour système KPS



Verwendung:
Zur Übertragung eines definierten Anzugsmomentes.
Application:
For the transfer of a defined torque.
Application:
Pour la transmission d'un couple de serrage défini.

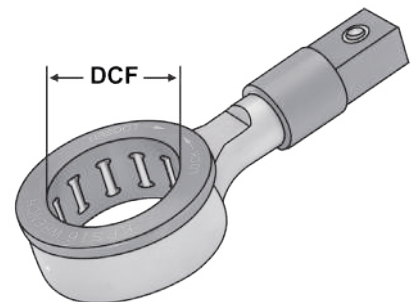

10

Bestell-Nr. Order no. Référence	Abmessung Size Dimension	DCF
800.03.10	490EK KPS 10	28
800.03.16	496EK KPS 16	40



K Hakenschlüssel für Hochleistungs-Kraftspannfutter | System HKS

Wrenches for High Performance Milling Chuck | HKS-system

Clés à ergot pour Mandrin de serrage à haute performance | Système HKS



Verwendung:

Zum Spannen der HKS Spannfutter.

Application:

For clamping the HKS collet chucks.

Application:

Pour le serrage des mandrins système HKS.

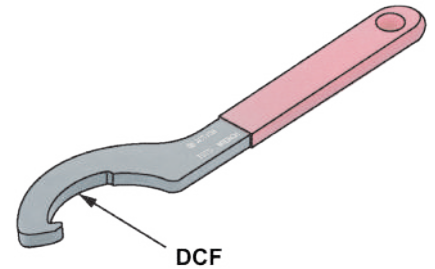

Bestell-Nr. Order no. Référence	Abmessung Size Dimension	D
64.182.20	HKS 20	50
64.182.32	HKS 25 + HKS 32	60

Auszieher für Hochleistungs-Kraftspannfutter | System HKS

Extractor for reduction sleeves High Performance Milling Chuck | HKS-system

Extracteur pour douilles de réduction Mandrin de serrage à haute performance | Système HKS



Verwendung:

Zum Herausziehen der Reduzierungen.

Application:

For extracting the reduction sleeves.

Application:

Pour extraire les douilles de réduction.

10

Bestell-Nr. Order no. Référence	Abmessung Size Dimension
64.187.2032	HKS 20 HKS 25 HKS 32

Setting screw for High Performance Milling Chuck | HKS-system

Vis de réglage pour Mandrin de serrage à haute performance | Système HKS



Verwendung:
Zum Einstellen des Werkzeuges bei HKS Spannfutter.

Application:
For setting the tool in the HKS collet chucks.

Application:
Pour régler l'outil dans le mandrin HKS.

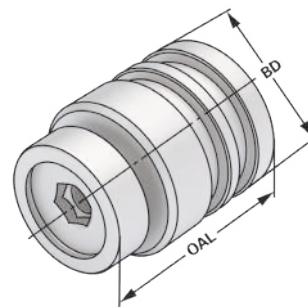

Bestell-Nr. Order no. Référence	Abmessung Size Dimension	OAL	BD
HKS20.184*	HKS 20	30	19
HKS25.184*	HKS 25	30	24
HKS32.184*	HKS 32	38	31

* Nicht mit Reduzierungen einsetzbar
 * Not applicable with reductions
 * Pas utilisable avec réductions





Spannmuttern ISO 10897 (DIN 6388 D) System OZ, kugelgelagerte Ausführung

Clamping nuts ISO 10897 (DIN 6388 D) OZ-system, ball-bearing version

Ecrous de serrage ISO 10897 (DIN 6388 D) système OZ, version roulement à billes



Verwendung:

Alle Spannzangen mit Außenform ISO 10897 (DIN 6388 D) können gespannt werden.

Application:

All collets with outside form ISO 10897 (DIN 6388 D) can be clamped.

Application:

Toutes les pinces avec une forme extérieure suivant ISO 10897 (DIN 6388 D) peuvent être serrées.

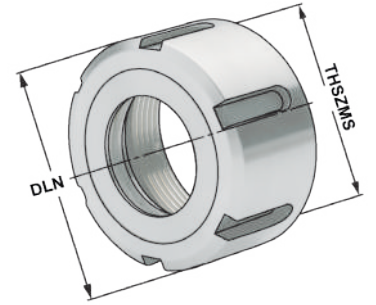

ISO 10897

13.04

Bestell-Nr. Order no. Référence	Ausführung Version Type	NORM	DCONWS	DLN	HLN	TQX	THSZMS
112.01.16	415E OZ 16	ISO 10897	2 - 16	43	24	85	M33 x 1,5
112.01.25	462E OZ 25	ISO 10897	2 - 25	60	30	140	M48 x 2
112.01.32	467E OZ 32	ISO 10897	3 - 32	72	34	170	M60 x 2,5



Werkzeugparameter nach ISO 13399

Dieser Katalog wurde gemäß ISO 13399 „Werkzeugdatendarstellung und -austausch“ erstellt, um eine einfache Handhabung der Werkzeug- und Produktdaten, auch für Kunden die noch nicht mit KEMMLER Produkten vertraut sind, zu ermöglichen.

Tool parameters according to ISO 13399

This catalogue has been prepared in accordance with ISO 13399 „Cutting tool data representation and exchange“ to enable easy handling of tool and product data, even for customers who are not yet familiar with KEMMLER products.

Paramètres de l'outil selon ISO 13399

Ce catalogue a été créé conformément à la norme ISO 13399 „Données d'outils et échange d'outils“ afin de permettre l'utilisation simple des données d'outils et des produits, même pour les clients qui ne connaissent pas encore les produits KEMMLER.

10

ISO 13399	Deutsch	English	Français
BD	Körper-Durchmesser	Body diameter	Diamètre du corps
DCONWS	Spann-Ø, nominal, werkst.seitig	Clamping Ø, nominal, workpc. side	Ø de serrage, nominal, côté pièce à usiner - Plage
DLN	Außendurchmesser Spannmutter	Diameter lock nut	Diamètre extérieur écrou de serrage
HLN	Höhe Spannmutter	Lock nut height	Hauteur de l'écrou de serrage
LB	Grundkörperlänge	Body length	Longueur de corps principal
LF	Funktionslänge	Functional length	Longueur fonctionnelle
LPR	Kraglänge	Protruding length	Longueur du porte-à-faux (saillante)
OAL	Gesamtlänge	Overall length	Longueur totale
THID	Gewindebezeichnung, innen	Thread designation inside	Désignation du filetage intérieur
THSZMS	Aufnahmegewindenenggröße, masch.seitig	Connection thread nominal size	Dimension nominale du filetage, côté machine
TQX	Drehmoment, max.	Torque maximum	Couple de serrage max.

Clamping nuts ISO 15488 (DIN 6499) ER-system, standard type with eccentric ring, balanced

Ecrous de serrage ISO 15488 (DIN 6499) système ER, version standard avec bague excentrique, équilibrés



Verwendung:

Alle Spannzangen mit Außenform ISO 15488 (DIN 6499) können gespannt werden.

Application:

All collets with outside form ISO 15488 (DIN 6499) can be clamped.

Application:

Toutes les pinces avec une forme extérieure suivant ISO 15488 (DIN 6499) peuvent être serrées.

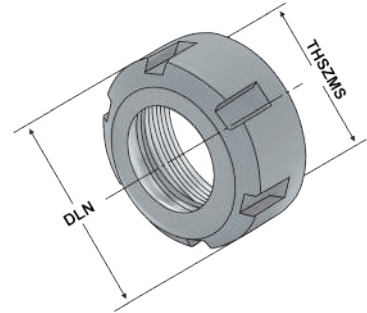

ISO 15488

13.04

Bestell-Nr. Order no. Référence	Ausführung Version Type	NORM	DCONWS	DLN	HLN	TQX	THSZMS
110.02.10	426E ER 16	ISO 15488	1 - 10	32	17,5	50	M22 × 1,5
110.02.13	428E ER 20	ISO 15488	2 - 13	35	19,0	75	M25 × 1,5
110.02.16	430E ER 25	ISO 15488	2 - 16	42	20,0	85	M32 × 1,5
110.02.20	470E ER 32	ISO 15488	2 - 20	50	22,5	105	M40 × 1,5
110.02.26	472E ER 40	ISO 15488	3 - 26	63	25,5	150	M50 × 1,5



Spannmuttern ISO 15488 (DIN 6499) System ER, Sechskantmutter

Clamping nuts ISO 15488 (DIN 6499) ER-system, Hexagonal clamping nut

Ecrous de serrage ISO 15488 (DIN 6499) système ER, Écrou hexagonal



Verwendung:

Alle Spannzangen mit Außenform ISO 15488 (DIN 6499) können gespannt werden.

Application:

All collets with outside form ISO 15488 (DIN 6499) can be clamped.

Application:

Toutes les pinces avec une forme extérieure suivant ISO 15488 (DIN 6499) peuvent être serrées.

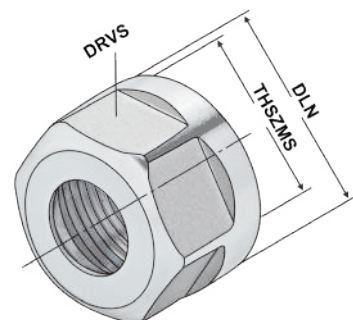

10

ISO 15488

Bestell-Nr. Order no. Référence	Ausführung Version Type	NORM	DCONWS	DRVS	DLN	HLN	TQX	THSZMS
110.02.07.6	4008E ER 11	ISO 15488	1 - 7	17	19	11,3	30	M14 × 0,75
110.02.10.6	426E ER 16	ISO 15488	1 - 10	25	28	18,5	40	M22 × 1,5
110.02.13.6	428E ER 20	ISO 15488	2 - 13	30	34	20,0	60	M25 × 1,5
110.02.16.6	430E ER 25	ISO 15488	2 - 16	38	42	23,0	60	M32 × 1,5



Spannmuttern ISO 15488 (DIN 6499) System ER - Mini

Standardausführung mit Exzentering, gewuchtet

Clamping nuts ISO 15488 (DIN 6499) ER-system - Mini, standard type with eccentric ring, balanced
 Ecrous de serrage ISO 15488 (DIN 6499) système ER - Mini, version standard avec bague excentrique, équilibrés



Verwendung:
 Alle Spannzangen mit Außenform ISO 15488 (DIN 6499) können gespannt werden.

Application:
 All collets with outside form ISO 15488 (DIN 6499) can be clamped.

Application:
 Toutes les pinces avec une forme extérieure suivant ISO 15488 (DIN 6499) peuvent être serrées.

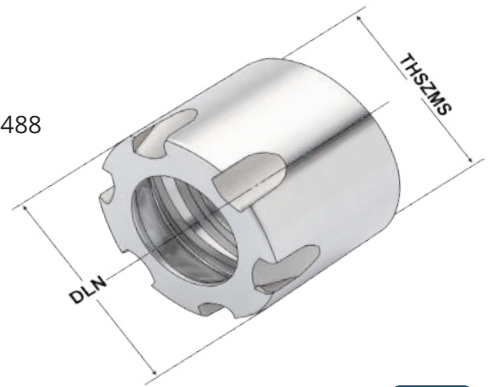

ISO 15488



Bestell-Nr. Order no. Référence	Ausführung Version Type	NORM	DCONWS	DLN	HLN	TQX	THSZMS
110.02.05.3	4004E ER 8	ISO 15488	1 - 5	12	10,8	4	M10 × 0,75
110.02.07.3	4008E ER 11	ISO 15488	1 - 7	16	11,3	20	M13 × 0,75
110.02.10.3	426E ER 16	ISO 15488	1 - 10	22	18,0	30	M19 × 1
110.02.13.3	428E ER 20	ISO 15488	2 - 13	28	19,0	40	M24 × 1
110.02.16.3	430E ER 25	ISO 15488	2 - 16	35	20,0	60	M30 × 1



Spannmuttern ISO 15488 (DIN 6499) System ER, gleitgelagerte Ausführung

Clamping nuts ISO 15488 (DIN 6499) ER-system, sleeve-bearing version
 Ecrous de serrage à palier lisse pour pinces ISO 15488 (DIN 6499) système ER



Verwendung:
 Alle Spannzangen mit Außenform ISO 15488 (DIN 6499) können gespannt werden.

Application:
 All collets with outside form ISO 15488 (DIN 6499) can be clamped.

Application:
 Toutes les pinces avec une forme extérieure suivant ISO 15488 (DIN 6499) peuvent être serrées.

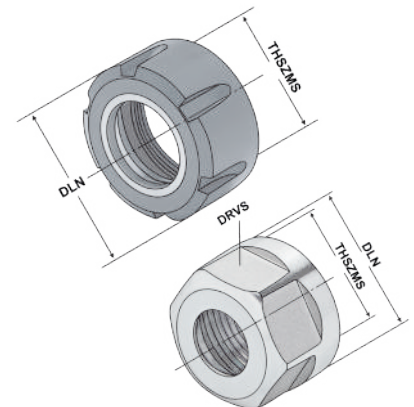

ISO 15488

Bestell-Nr. Order no. Référence	Ausführung Version Type	NORM	DCONWS	DRVS	DLN	HLN	TQX	THSZMS
112.02.10*	426E ER 16	ISO 15488	1 - 10	25	28	20,3	40	M22 × 1,5
112.02.13	428E ER 20	ISO 15488	2 - 13		35	21,8	75	M25 × 1,5
112.02.16	430E ER 25	ISO 15488	2 - 16		42	22,4	85	M32 × 1,5
112.02.20	470E ER 32	ISO 15488	2 - 20		50	25,0	105	M40 × 1,5
112.02.26	472E ER 40	ISO 15488	3 - 26		63	28,3	150	M50 × 1,5

* Sechskantmutter
 * Hexagonal clamping nut
 * Écrou hexagonal

10

für Präzisions-Spannzangenfutter ER

Clamping nuts ER32 | 2-20 | balanced ISO 15488 for precision collet chuck
 EREcrous de serrage à paE-crous de serrage ER32 | 2-20 | équilibré ISO 15488 pour mandrin à pinces ER de précision



Verwendung:
 Alle Spannzangen mit Außenform ISO 15488 (DIN 6499) können gespannt werden.

Application:
 All collets with outside form ISO 15488 (DIN 6499) can be clamped.

Application:
 Toutes les pinces avec une forme extérieure suivant ISO 15488 (DIN 6499) peuvent être serrées.

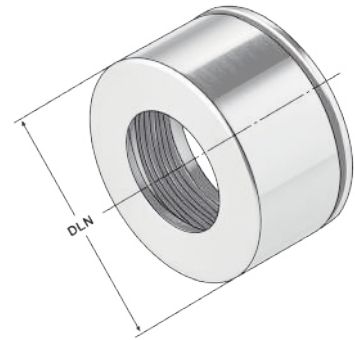

ISO
15488

13.04

Bestell-Nr. Order no. Référence	Ausführung Version Type	NORM	DCONWS	DLN	HLN	TQX	THSZMS
110.P2.20	470 E ER 32	~ ISO 15488	2 - 20	28	27	170	M40 × 1,5





Spannmuttern ISO 10897 (DIN 6388 D) System OZ, für Dichtscheiben

Clamping nuts ISO 10897 (DIN 6388 D) OZ-system, for sealing discs
Ecrous de serrage ISO 10897 (DIN 6388 D) système OZ, pour joints



Verwendung:
Zur Abdichtung von Werkzeugen mit Innenkühlung in Spannfutter DIN 6391, System OZ.

Application:
For sealing tools with internal cooling in collet chucks DIN 6391, OZ-system.

Application:
Pour assurer l'étanchéité en cas d'utilisation d'outils avec lubrification interne dans mandrins à pinces DIN6391, système OZ.

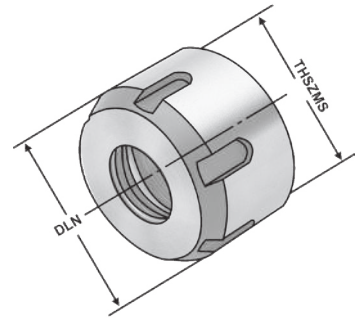

ISO
10897

13.04

Bestell-Nr. Order no. Référence	Ausführung Version Type	NORM	DCONWS	DLN	HLN	TQX	THSZMS
113.01.16	415E OZ 16	ISO 10897	2 - 16	43	31,5	85	M33 × 1,5
113.01.25	462E OZ 25	ISO 10897	2 - 25	60	30,0	140	M48 × 2
113.01.32	467E OZ 32	ISO 10897	3 - 32	72	33,5	170	M60 × 2,5

Hinweis: Dichtscheiben sind getrennt zu bestellen.
Note: Sealing discs be ordered separately.
Observation: Joints doivent être commandés séparément.



Sealing discs for clamping nuts OZ-system
 Joints pour écrous de serrage système OZ



Verwendung:
 Zur Abdichtung von Werkzeugen mit
 Innenkühlung.
Application:
 For sealing tools with internal cooling.
Application:
 Pour assurer l'étanchéité en cas
 d'utilisation d'outils avec lubrification
 interne.

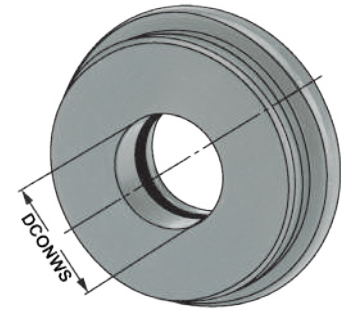

ISO
10897

13.04

Bestell-Nr. Order no. Référence	Typ	DCONWS
01.16.xxx	415E OZ 16	2 - 16
01.25.xxx	462E OZ 25	2 - 25
01.32.xxx	467E OZ 32	3 - 32

d* Ø des Werkzeugs
 Spannüberbrückung 0,5 mm (+0,1/-0,4)
 d* Ø of the tool
 Clamping range 0.5 mm (+0.1/-0.4)
 d* Ø d'outil
 Plage de serrage de 0,5 mm (+0,1/-0,4)

Hinweis: Dicht bis 80 bar Druck
Note: Sealing capacity up to 80 bar
Observation: Étanche jusqu'à la pression de 80 bar





Spannmuttern ISO 15488 (DIN 6499) System ER, für Dichtscheiben

Clamping nuts ISO 15488 (DIN 6499) ER-system, for sealing discs
Ecrous de serrage ISO 15488 (DIN 6499) système ER, pour joints



Verwendung:
Zur Abdichtung von Werkzeugen mit Innenkühlung in Spannfutter, System ER.

Application:
For sealing tools with internal cooling in collet chucks, ER-system.

Application:
Pour assurer l'étanchéité en cas d'utilisation d'outils avec lubrification interne dans mandrins à pinces, système ER.

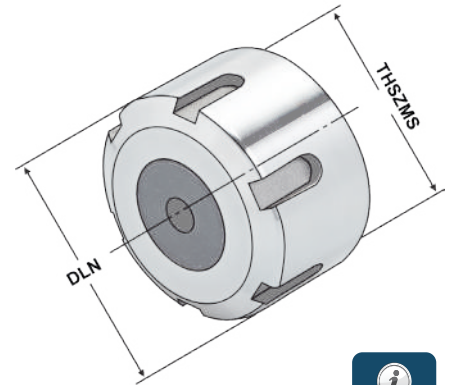

ISO
15488

13.04

Bestell-Nr. Order no. Référence	Ausführung Version Type	NORM	DCONWS	DLN	HLN	TQX	THSZMS
113.02.13	428E ER 20	ISO 15488	2 - 13	35	26,5	75	M25 × 1,5
113.02.16	430E ER 25	ISO 15488	2 - 16	42	27,5	85	M32 × 1,5
113.02.20	470E ER 32	ISO 15488	2 - 20	50	30,5	105	M40 × 1,5
113.02.26	472E ER 40	ISO 15488	3 - 26	63	34,0	150	M50 × 1,5

Hinweis: Dichtscheiben sind getrennt zu bestellen.
Note: Sealing discs be ordered separately.
Observation: Joints doivent être commandés séparément.

Spannmuttern ISO 15488 (DIN 6499) System ER - Sechskantmutter, für Dichtscheiben

Clamping nuts ISO 15488 (DIN 6499) ER-system - Hexagonal clamping nut, for sealing discs
Ecrous de serrage ISO 15488 (DIN 6499) système ER - Écrou hexagonal, pour joints



Verwendung:
Zur Abdichtung von Werkzeugen mit Innenkühlung in Spannfutter, System ER.

Application:
For sealing tools with internal cooling in collet chucks, ER-system.

Application:
Pour assurer l'étanchéité en cas d'utilisation d'outils avec lubrification interne dans mandrins à pinces, système ER.

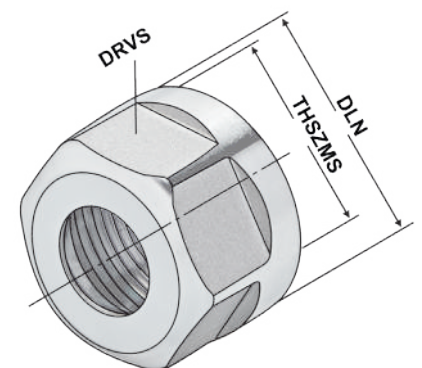

10

ISO
15488

Bestell-Nr. Order no. Référence	Ausführung Version Type	NORM	DCONWS	DRVS	DLN	HLN	TQX	THSZMS
113.02.10	426E ER 16	ISO 15488	1 - 10	25	28	25	40	M22 × 1,5

Hinweis: Dichtscheiben sind getrennt zu bestellen.
Note: Sealing discs be ordered separately.
Observation: Joints doivent être commandés séparément.

Spannmuttern ISO 15488 (DIN 6499) System ER Mini, für Dichtscheiben



Clamping nuts ISO 15488 (DIN 6499) ER-system Mini, for sealing discs
Ecrrous de serrage ISO 15488 (DIN 6499) système ER Mini, pour joints

Minimutter
Mini nut
Ecrrous mini



Verwendung:
Zur Abdichtung von Werkzeugen mit Innenkühlung in Spannfutter, System ER.

Application:
For sealing tools with internal cooling in collet chucks, ER-system.

Application:
Pour assurer l'étanchéité en cas d'utilisation d'outils avec lubrification interne dans mandrins à pinces, système ER.

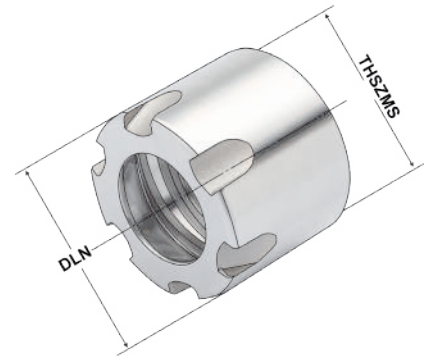

Bestell-Nr. Order no. Référence	Ausführung Version Type	NORM	DCONWS	DLN	HLN	TQX	THSZMS
113.02.10M	426E ER 16	ISO 15488	1 - 10	22	24,4	30	M19 x 1

Hinweis: Dichtscheiben sind getrennt zu bestellen.
Note: Sealing discs be ordered separately.
Observation: Joints doivent être commandés séparément.

Spannmuttern ISO 15488 (DIN 6499) System ER, mit Spritzdüsen, für Dichtscheiben

Clamping nuts ISO 15488 (DIN 6499) ER-system, with spray nozzles, for sealing discs
Ecrrous de serrage ISO 15488 (DIN 6499) système ER, avec gicleurs, pour joints



Verwendung:
Zur Abdichtung von Werkzeugen mit Innenkühlung in Spannfutter, System ER mit Spritzdüsen.

Application:
For sealing tools with internal cooling in collet chucks, ER-system with spray nozzles.

Application:
Pour assurer l'étanchéité en cas d'utilisation d'outils avec lubrification interne dans mandrins à pinces, système ER avec buses d'injection.

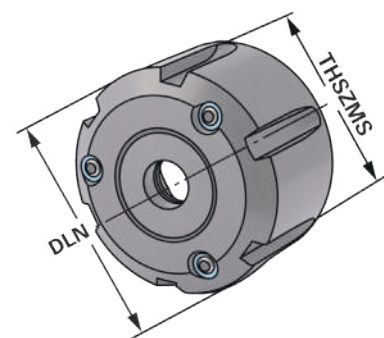

10

ISO
15488

Bestell-Nr. Order no. Référence	Ausführung Version Type	NORM	DCONWS	DLN	HLN	TQX	THSZMS
114.02.10	426E ER 16	ISO 15488	1 - 10	28	25	40	M22 x 1,5
114.02.16	430E ER 25	ISO 15488	2 - 16	42	27,5	85	M32 x 1,5
114.02.20	470E ER 32	ISO 15488	2 - 20	50	30,5	105	M40 x 1,5
114.02.26	472E ER 40	ISO 15488	3 - 26	63	34,0	150	M50 x 1,5

Hinweis: Dichtscheiben sind getrennt zu bestellen.
Note: Sealing discs be ordered separately.
Observation: Joints doivent être commandés séparément.

K Dichtscheiben für Spannmuttern System ER

Sealing discs for clamping nuts ER-system
 Joints pour écrous de serrage système ER



Verwendung:
 Zur Abdichtung von Werkzeugen mit
 Innenkühlung.

Application:
 For sealing tools with internal cooling.

Application:
 Pour assurer l'étanchéité en cas
 d'utilisation d'outils avec lubrification
 interne.

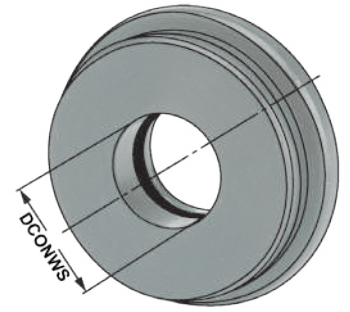

ISO
 15488

i
 13.04

Bestell-Nr. Order no. Référence	Typ	DCONWS
02.10M.xxx	426E ER 16 Mini	1,0 – 10,0
02.10.xxx	426E ER 16	1,0 – 10,0
02.13.xxx	428E ER 20	3,0 – 13,0
02.16.xxx	430E ER 25	1,0 – 16,0
02.20.xxx	470E ER 32	1,0 – 20,0
02.26.xxx	472E ER 40	2,0 – 26,0

d* Ø des Werkzeugs
 Spannüberbrückung 0,5 mm (+0,1/-0,4)

d* Ø of the tool
 Clamping range 0.5 mm (+0.1/-0.4)

d* Ø d'outil
 Plage de serrage de 0,5 mm (+0,1/-0,4)

Hinweis: Dicht bis 80 bar Druck
Note: Sealing capacity up to 80 bar
Observation: Étanche jusqu'à la pression de 80 bar

10



10.16

KEMMLER

K24



Technische Datenblätter, STEP/STL Modelle für die Simulation der NC-Programme und DXF-Zeichnungen zur Erstellung des Einrichteblattes stehen Online zur Verfügung.

Technical data sheets, STEP/STL models for the simulation of NC programs and DXF drawings to create the tooling sheet are online available.

Fiches techniques, STEP/STL modèles techniques pour la simulation de programmes CN et dessins DXF pour créer la feuille d'installation sont disponible online.

Sie können unsere Kataloge entweder direkt im Browser betrachten oder sie auf Ihren PC, Smartphone oder Tablet herunterladen (PDF-Reader notwendig).

You can view our catalogues either directly in the browser or download to your PC, smartphone or tablet (PDF reader required).

Vous pouvez consulter nos catalogues directement dans le navigateur ou télécharger sur votre PC, smartphone ou tablet (lecteur PDF requis).

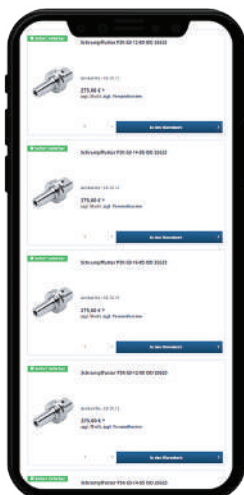

Auf unserer Internetseite können Sie auch die Lagerverfügbarkeit prüfen - auch auf Mobilgeräten.

On our website you can also check the stock availability - also on mobile devices.

Vous pouvez également vérifier la disponibilité de nos produits sur le site Internet - ainsi que sur vos appareils



Verwendung:
Zur Übertragung eines definierten Anzugsmomentes.

Application:
For the transfer of a defined torque.

Application:
Pour la transmission d'un couple de serrage défini.

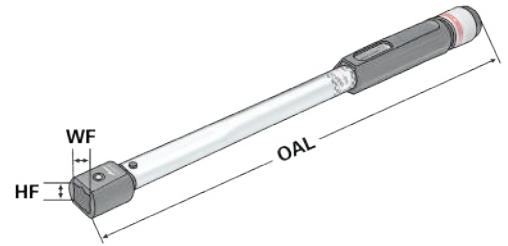

Bestell-Nr. Order no. Référence	Drehmoment Torque Couple	OAL	WF	HF
800.010	20 – 100 Nm	430	18	14
800.030	60 – 300 Nm	580	18	14

Maul-Einsteckwerkzeug für Spannmuttern System ER, mit Sechskant

Open jaw plug-in head for clamping nuts ER-system, with hexagon

Embout à fourche pour clés dynamométriques pour écrous de serrage système ER, avec hexagone

10



Verwendung:
Zur Übertragung eines definierten Anzugsmomentes.

Application:
For the transfer of a defined torque.

Application:
Pour la transmission d'un couple de serrage défini.

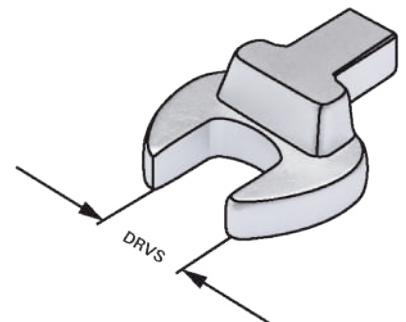

ISO
15488

Bestell-Nr. Order no. Référence	Ausführung Version Type	DRVS	WF	HF
800.02.10	426E ER 16	25	18	14
800.02.10.2	426E ER 16	27	18	14
800.02.13.1	428E ER 20	30	18	14

Einsteckwerkzeug für Spannmuttern System OZ



Plug-in head for clamping nuts OZ-system

Embout pour clés dynamométriques pour écrous de serrage système OZ



Verwendung:
Zur Übertragung eines definierten Anzugsmomentes.

Application:
For the transfer of a defined torque.

Application:
Pour la transmission d'un couple de serrage défini.

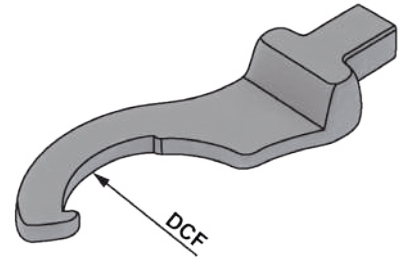

ISO
10897

Bestell-Nr. Order no. Référence	Ausführung Version Type	DCF	WF	HF
800.01.16	415E OZ 16	40	18	14
800.01.25	462E OZ 25	58	18	14
800.01.32	467E OZ 32	68	18	14

Einsteckwerkzeug für Spannmuttern System ER

Plug-in head for clamping nuts ER-system

Embout pour clés dynamométriques pour écrous de serrage système ER



Verwendung:
Zur Übertragung eines definierten Anzugsmomentes.

Application:
For the transfer of a defined torque.

Application:
Pour la transmission d'un couple de serrage défini.

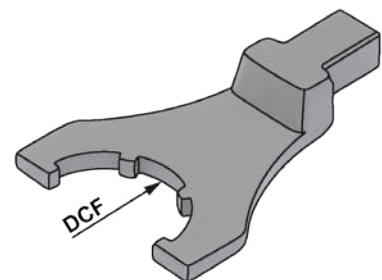

10

ISO
15488

Bestell-Nr. Order no. Référence	Ausführung Version Type	DCF	WF	HF
800.02.10.1	426E ER 16	32	18	14
800.02.13	428E ER 20	35	18	14
800.02.16	430E ER 25	42	18	14
800.02.20	470E ER 32	50	18	14
800.02.26	472E ER 40	63	18	14

K Rollenschlüssel-Einsteckwerkzeug für System KPS

Roller Bearing plug-in head for KPS-system
 Embout pour clés à rouleaux pour système KPS



Verwendung:
 Zur Übertragung eines definierten Anzugsmomentes.
Application:
 For the transfer of a defined torque.
Application:
 Pour la transmission d'un couple de serrage défini.

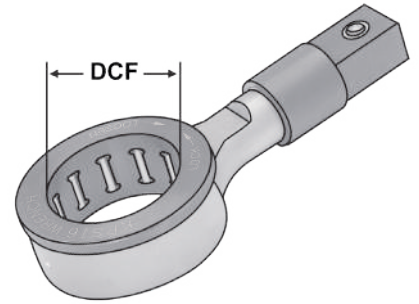

KPS

Bestell-Nr. Order no. Référence	Ausführung Version Type	DCF	WF	HF
800.03.10	490EK KPS 10	28	18	14
800.03.16	496EK KPS 16	40	18	14

Rollenschlüssel-Einsteckwerkzeug für Präzisions-Spannzangenfutter System ER

Roller Bearing plug-in head for precision collet chucks ER-system
 Embout pour clés à rouleaux pour mandrins à pinces de précision système ER



Verwendung:
 Zur Übertragung eines definierten Anzugsmomentes.
Application:
 For the transfer of a defined torque.
Application:
 Pour la transmission d'un couple de serrage défini.

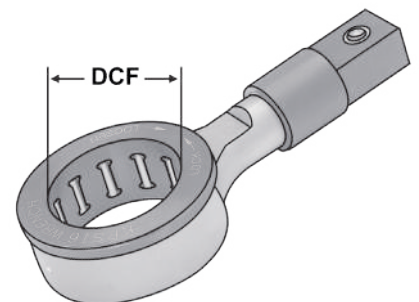

10

Bestell-Nr. Order no. Référence	Ausführung Version Type	DCF	WF	HF
800.P2.20	470E ER 32	50	18	14



10.18

Plug-in head for system HKS

Embout pour clés dynamométriques pour système HKS



Verwendung:
Zur Übertragung eines definierten Anzugsmomentes.

Application:
For the transfer of a defined torque.

Application:
Pour la transmission d'un couple de serrage défini.

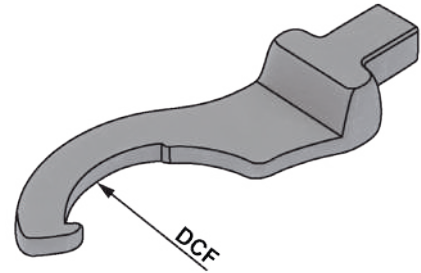

HKS

Bestell-Nr. Order no. Référence	Ausführung Version Type	DCF	WF	HF
800.64.20	HKS 20	50	18	14
800.64.32	HKS 25 + HKS 32	60	18	14

Maul-Einsteckwerkzeug für Anzugsbolzen

Open jaw plug-in head for Pull studs

Embout à fourche pour tirettes



Verwendung:
Zur Übertragung eines definierten Anzugsmomentes.

Application:
For the transfer of a defined torque.

Application:
Pour la transmission d'un couple de serrage défini.

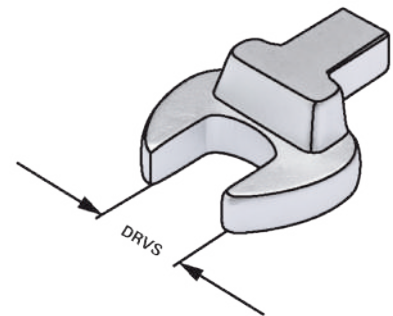

10

Bestell-Nr. Order no. Référence	Ausführung Version Type	DRVS	WF	HF
800.20.13	BT 30	13	18	14
800.20.14	SK 30	14	18	14
800.20.19	SK / BT 40	19	18	14
800.20.30	SK / BT 50	30	18	14



K Sechskantschlüssel

Hexagonal wrench
Clés hexagonale



Verwendung:
Für CNC Bohrfutter und Hydrodehnspannfutter.
Application:
For CNC drill chucks and hydraulic chucks.
Application:
Pour Mandrin de perçage CNC et mandrin expansibles hydrauliques.

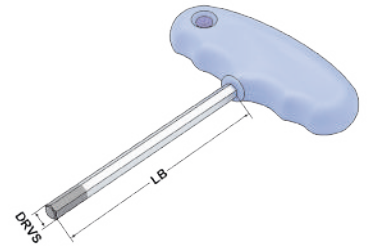

Bestell-Nr. Order no. Référence	Abmessung Size Dimension	DRVS	LB
T-4-100	4-100	4	100
T-5-100	5-100	5	100
T-6-100	6-100	6	100

Hakenschlüssel DIN 1810 A für Spannmuttern System OZ



Wrenches DIN 1810 A for clamping nuts OZ-system

Clés à ergot DIN 1810 A pour écrous de serrage système OZ



Verwendung:
Für Spannmuttern System OZ.
Application:
For clamping nuts OZ-system.
Application:
Pour écrous de serrage système OZ.

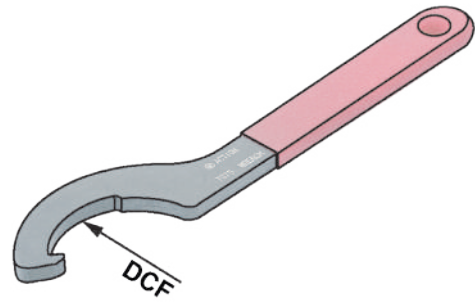

ISO
10897

DIN
1810 A

Bestell-Nr. Order no. Référence	Ausführung Version Type	DCF
01.16	415E OZ 16	40
01.25	462E OZ 25	58
01.32	467E OZ 32	68

Spannschlüssel DIN 6368 für Aufsteckdorne

Wrenches DIN 6368 for shell arbors

Clés de serrage DIN 6368 pour broches creuses

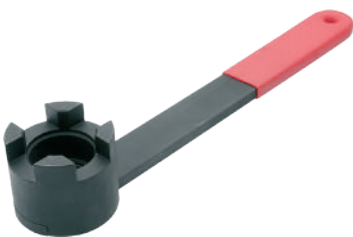

Verwendung:
Für Fräseranzugsschraube DIN 6367.
Application:
For retaining screw DIN 6367.
Application:
Pour vis de fixation DIN 6367.

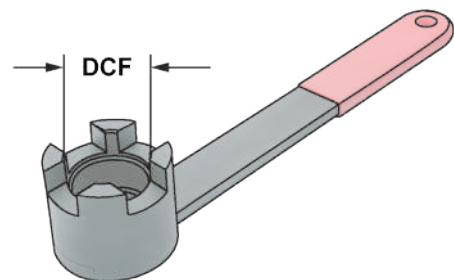

10

DIN
6368

DIN
6367

Bestell-Nr. Order no. Référence	DCF
10.16	16 M8
10.22	22 M10
10.27	27 M12
10.32	32 M16
10.40	40 M20
10.50	50 M24
10.60	60 M30

K Spannschlüssel für Spannmuttern System ER

Wrenches for clamping nuts ER-system
Clés de serrage pour écrous de serrage système ER



Verwendung:
Für Spannmuttern System ER.
Application:
For clamping nuts ER-system.
Application:
Pour écrous de serrage système ER.

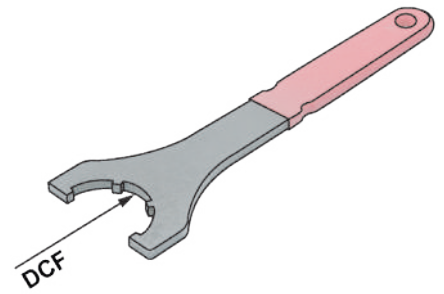

ISO
15488

Bestell-Nr. Order no. Référence	Ausführung Version Type	DCF
02.10.1	426E ER 16	32
02.13	428E ER 20	35
02.16	430E ER 25	42
02.20	470E ER 32	50
02.26	472E ER 40	63

Spannschlüssel für Spannmuttern System ER

Wrenches for clamping nuts ER-system
Clés de serrage pour écrous de serrage système ER



Verwendung:
Für Spannmuttern System ER.
Application:
For clamping nuts ER-system.
Application:
Pour écrous de serrage système ER.

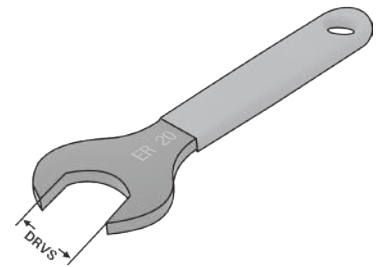

ISO
15488

Bestell-Nr. Order no. Référence	Ausführung Version Type	DRVS
02.07	4008E ER 11	17
02.10	426E ER 16	25
02.10.2	426E ER 16	27
02.13.1	428E ER 20	30
02.16.1	430E ER 25	42

Für Sechskantmutter
For hexagonal clamping nut
Pour écrou hexagonal

10

Spannschlüssel für Spannmuttern System ER - Mini



Wrenches for clamping nuts ER-system - Mini

Clés de serrage pour écrous de serrage système ER - Mini



Verwendung:
Für Mini-Spannmuttern System ER.
Application:
For mini clamping nuts ER-system.
Application:
Pour écrous de serrage mini système ER.

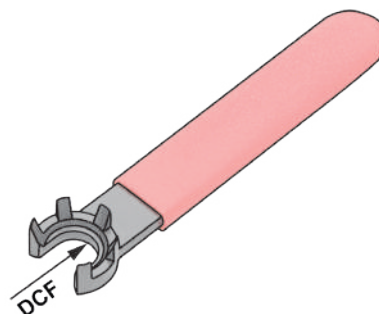

ISO
15488

Bestell-Nr. Order no. Référence	Ausführung Version Type	DCF
02.07.3	4008E ER 11	16
02.10.3	426E ER 16	22
02.13.3	428E ER 20	28
02.16.3	430E ER 25	37

Spannschlüssel für Präzisions-Spannzangenfutter System ER

Wrenches for precision collet chucks

Clés de serrage pour mandrins à pinces de précision système ER



Verwendung:
Für Spannmuttern System ER.
Application:
For clamping nuts ER-system.
Application:
Pour écrous de serrage système ER.

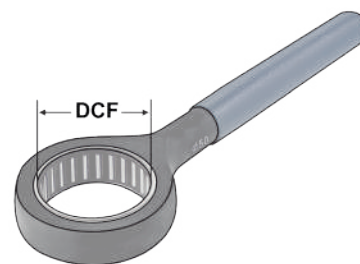

10

Bestell-Nr. Order no. Référence	Ausführung Version Type	DCF
02.P2.20	470E ER 32	50

K Anzugsbolzen ISO 7388-3 | Schaftform AD

mit zentrischer innerer Kühlmittel-Zufuhr | ehemals DIN 69872 A

Pull studs ISO 7388-3 | shank form AD | Centric inner cooling supply | formerly DIN 69872 A
Tirettes ISO 7388-3 | forme AD | avec arrosage interne centré | l'ancien DIN 69872 A

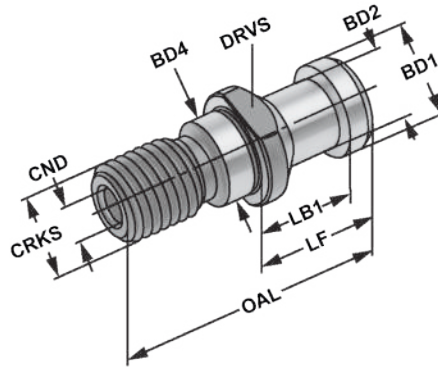

Bestell-Nr. Order no. Référence	CRKS	OAL	LF	LB1	BD1	BD2	BD4	CND	BHTA	DRVS
302.20.12	M12	44	24	19	13	9	13	3,0	15°	14
402.20.16	M16	54	26	20	19	14	17	7,0	15°	19
502.20.24	M24	74	34	25	28	21	25	11,5	15°	30

Form AD | mit Durchgangsbohrung | ohne O-Ring | ehemals DIN 69872 A
Form AD | with drill through | without O-ring | formerly DIN 69872 A
Forme AD | percée | sans joint torique | l'ancien DIN 69872 A

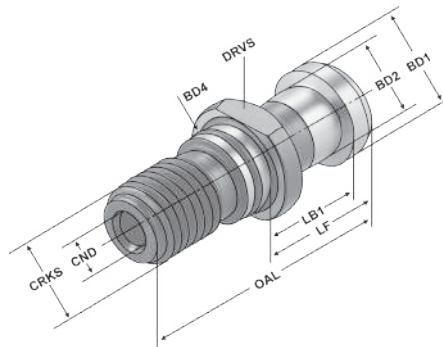

10

Bestell-Nr. Order no. Référence	CRKS	OAL	LF	LB1	BD1	BD2	BD4	CND	BHTA	DRVS
402.20.16.0	M16	54	26	20	19	14	17	7,0	15°	19
502.20.24.0	M24	74	34	25	28	21	25	11,5	15°	30

Form AD | mit Durchgangsbohrung | inkl. O-Ring | ehemals DIN 69872 A
Form AD | with drill through | incl. O-ring | formerly DIN 69872 A
Forme AD | percée | avec joint torique | l'ancien DIN 69872 A

Verwendung:
Für Werkzeuge mit Steilkegelschaft ISO 7388-1 (ehemals DIN 69871)

Application:
For tools with taper shanks ISO 7388-1 (formerly DIN 69871)

Utilisation:
Pour les outils avec queue conique ISO 7388-1 (l'ancien DIN 69871)



Pull studs ISO 7388-3 | shank form AF | Without cooling lubricant supply | formerly DIN 69872 B
Tirettes ISO 7388-3 | forme AF | sans arrosage | l'ancien DIN 69872 A

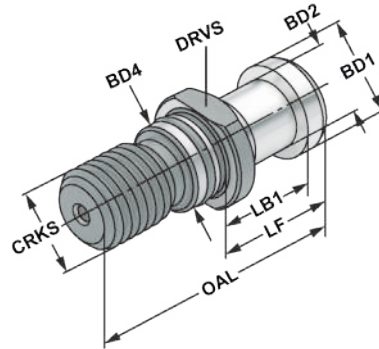

Bestell-Nr. Order no. Référence	CRKS	OAL	LF	LB1	BD1	BD2	BD4	CND	BHTA	DRVS
403.20.16	M16	54	26	20	19	14	17	-	15°	19
503.20.24	M24	74	34	25	28	21	25	-	15°	30

Form AF | ohne Durchgangsbohrung | inkl. O-Ring | ehemals DIN 69872 B / DIN 69872 Form B
Form AF | sealed | incl. O-ring | formerly DIN 69872 B / DIN 69872 Form B
Forme AF | étanche | avec joint torique | l'ancien DIN 69872 B / DIN 69872 Form B

Verwendung:
Für Werkzeuge mit Steilkegelschaft ISO 7388-1 (ehemals DIN 69871)

Application:
For tools with taper shanks ISO 7388-1 (formerly DIN 69871)

Utilisation:
Pour les outils avec queue conique ISO 7388-1 (l'ancien DIN 69871)



K Anzugsbolzen ähnlich ISO 7388-3 | Schaftform AD | um 3 mm verlängert mit zentrischer innerer Kühlmittel-Zufuhr | ehemals DIN 69872 A

Pull studs ISO 7388-3 | shank form AD | Centric inner cooling supply | lengthened by 3 mm
Tirettes ISO 7388-3 | forme AD | avec arrosage interne centré | allongée par 3 mm

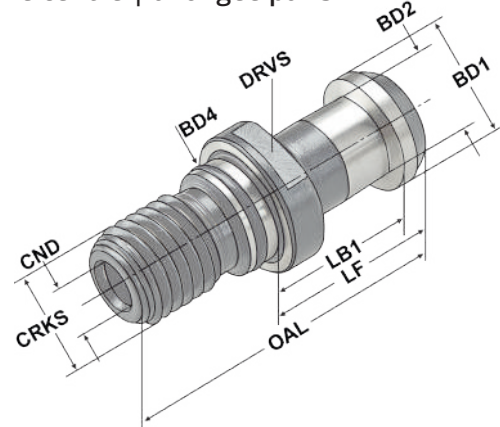

Bestell-Nr. Order no. Référence	CRKS	OAL	LF	LB1	BD1	BD2	BD4	CND	BHTA	DRVS	
402.20.16.21	M16	54	29	23	19	14	17	7,0	15°	19	
402.20.16.24	M16	54	29	23	19	14	17	4,0	15°	19	Okuma

Form AD | mit Durchgangsbohrung | inkl. O-Ring
Form AD | with drill through | incl. O-ring
Forme AD | percée | avec joint torique

Verwendung:
Für Werkzeuge mit Steilkegelschaft ISO 7388-1 (ehemals DIN 69871)
Art.Nr. 402.20.16.24 passend für „OKUMA“ und „MAKINO“ Werkzeugmaschinen

Application:
For tools with taper shanks ISO 7388-1 (formerly DIN 69871)
Suitable for „OKUMA“ and „MAKINO“ machine tools

Utilisation:
Pour les outils avec queue conique ISO 7388-1 (l'ancien DIN 69871)
Convient aux machines-outils „OKUMA“ et „MAKINO“



Pull studs Typ „Mori Seiki“ | shank form AD | Centric inner cooling supply | with O-Ring in the hole
 Tirettes type „Mori Seiki“ | forme AD | avec arrosage interne centré | avec joint torique dans l'alésage

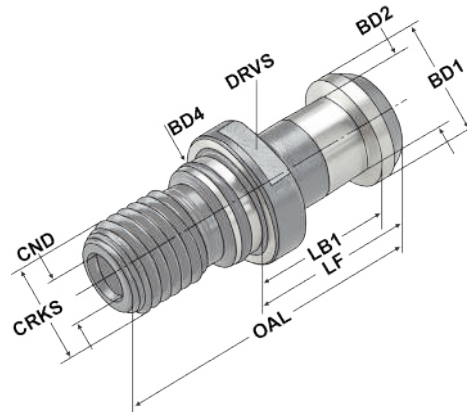

Bestell-Nr. Order no. Référence	CRKS	OAL	LF	LB1	BD1	BD2	BD4	CND	BHTA	DRVS
402.20.16.25	M16	54	29	23	19	14	17	7,0	15°	19
402.20.16.26	M16	54	26	20	19	14	17	7,0	15°	19

Form AD | mit Durchgangsbohrung | inkl. O-Ring | zzgl. O-Ring in der Bohrung
 Form AD | with drill through | incl. O-ring | plus O-ring in the bore
 Forme AD | percée | avec joint torique | plus joint torique dans l'alésage

Verwendung:
 Für Werkzeuge mit Steilkegelschaft ISO 7388-1 (ehemals DIN 69871)
 Für Werkzeuge mit Steilkegelschaft ISO 7388-2 (ehemals JIS B 6339 MAS-BT)
 Passend für „Mori Seiki“ Werkzeugmaschinen

Application:
 For tools with taper shanks ISO 7388-1 (formerly DIN 69871)
 For tools with taper shanks ISO 7388-2 (formerly JIS B 6339 MAS-BT)
 Suitable for „Mori Seiki“ machine tools

Utilisation:
 Pour les outils avec queue conique ISO 7388-1 (l'ancien DIN 69871)
 Pour les outils avec queue conique ISO 7388-2 (l'ancien JIS B 6339 MAS-BT)
 Convient aux machines-outils „Mori Seiki“



K Anzugsbolzen ISO 7388-3 | Schaftform UF ohne Kühlmittel-Zufuhr | ehemals ISO 7388

Pull studs ISO 7388-3 | shank form UF | without cooling lubricant supply | formerly ISO 7388
Tirettes ISO 7388-3 | forme UF | sans arrosage | l'ancien ISO 7388

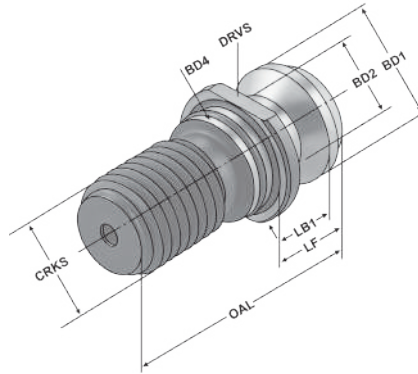

Bestell-Nr. Order no. Référence	CRKS	OAL	LF	LB1	BD1	BD2	BD4	CND	BHTA	DRVS
404.20.16.30	M16	44,5	16,40	11,15	18,95	12,95	17	-	45°	19
504.20.24.30.0	M24	65,5	25,55	17,95	29,10	19,60	25	-	45°	30

Form UF | ohne Durchgangsbohrung | inkl. O-Ring
Form UF | sealed | incl. O-ring
Forme UF | étanche | avec joint torique

504.20.24.30	M24	65,5	25,55	17,95	29,10	19,60	25	-	45°	30
--------------	-----	------	-------	-------	-------	-------	----	---	-----	----

Form UF | ohne Durchgangsbohrung | ohne O-Ring
Form UF | sealed | without O-ring
Forme UF | étanche | sans joint torique

Verwendung:
 Für Werkzeuge mit Steilkegelschaft ISO 7388-1 (ehemals DIN 69871)

Application:
 For tools with taper shanks ISO 7388-1 (formerly DIN 69871)

Utilisation:
 Pour les outils avec queue conique ISO 7388-1 (l'ancien DIN 69871)

10



10.30

KEMMLER

K24

Pull studs ISO 7388-3 | shank form UD | Centric inner cooling supply | formerly ISO 7388 B
Tirettes ISO 7388-3 | forme UD | avec arrosage interne centré | l'ancien ISO 7388 B

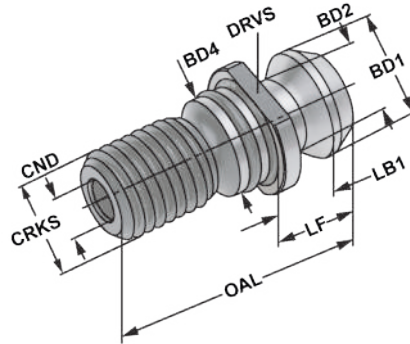

Bestell-Nr. Order no. Référence	CRKS	OAL	LF	LB1	BD1	BD2	BD4	CND	BHTA	DRVS
404.20.16	M16	44,5	16,40	11,15	18,95	12,95	17	7,0	45°	19
504.20.24	M24	65,5	25,55	17,95	29,10	19,60	25	11,5	45°	30

Form UD | mit Durchgangsbohrung | ohne O-Ring
Form UD | with drill through | without O-ring
Forme UD | percée | sans joint torique

404.20.16.0	M16	44,5	16,40	11,15	18,95	12,95	17	7,0	45°	19
504.20.24.0	M24	65,5	25,55	17,95	29,10	19,60	25	11,5	45°	30

Form UD | mit Durchgangsbohrung | inkl. O-Ring
Form UD | with drill through | incl. O-ring
Forme UD | percée | avec joint torique

Verwendung:
Für Werkzeuge mit Steilkegelschaft ISO 7388-1 (ehemals DIN 69871)

Application:
For tools with taper shanks ISO 7388-1 (formerly DIN 69871)

Utilisation:
Pour les outils avec queue conique ISO 7388-1 (l'ancien DIN 69871)





Anzugsbolzen ähnlich ISO 7388-3 | um 3 mm verlängert | Typ „MAZAK“

Schaftform UD | mit zentrischer innerer Kühlmittel-Zufuhr

*Pull studs similar to ISO 7388-3 | lengthened by 3 mm | Typ „MAZAK“
shank form UD | Centric inner cooling lubricant supply*

Tirettes ressemblant à ISO 7388-3 | allongée par 3 mm | Type „MAZAK“ | forme UD

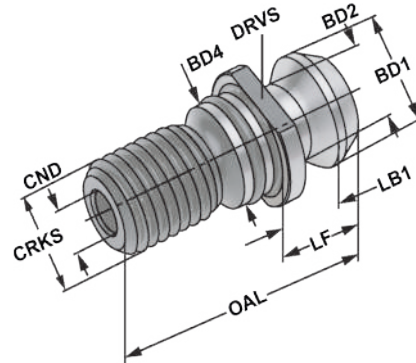

Bestell-Nr. Order no. Référence	CRKS	OAL	LF	LB1	BD1	BD2	BD4	CND	BHTA	DRVS
404.20.16.20	M16	47,50	19,25	14,15	18,95	12,95	17,00	7,3	45°	19

Form UD | mit Durchgangsbohrung | inkl. O-Ring
Form UD | with drill through | incl. O-ring
Forme UD | percée | avec joint torique

Verwendung:

Für Werkzeuge mit Steilkegelschaft ISO 7388-1 (ehemals DIN 69871)
Für Werkzeuge mit Steilkegelschaft ISO 7388-2 (ehemals JIS B 6339 MAS-BT)
Passend für „MAZAK“ und „FADAL“ Werkzeugmaschinen

Application:

For tools with taper shanks ISO 7388-1 (formerly DIN 69871)
For tools with taper shanks ISO 7388-2 (formerly JIS B 6339 MAS-BT)
Suitable for „MAZAK“ and „FADAL“ machine tools

Utilisation:

Pour les outils avec queue conique ISO 7388-1 (l'ancien DIN 69871)
Pour les outils avec queue conique ISO 7388-2 (l'ancien JIS B 6339 MAS-BT)
Convient aux machines-outils „MAZAK“ et „FADAL“

10



Sonderbolzen auf Anfrage kurzfristig lieferbar.
Special pull studs available within a short period upon request.
Tirettes spéciales livrables dans un délai court sur demande.



Pull studs Biesse and Leuco | without cooling lubricant supply

Tirettes Biesse et Leuco | sans arrosage

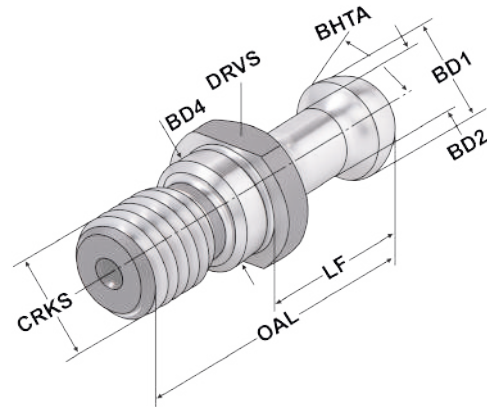

Bestell-Nr. Order no. Référence	CRKS	OAL	LF	BD1	BD2	BD4	BHTA	DRVS
302.20.12.25	M12	44	24	12	8	13	R3,2	14

ohne Durchgangsbohrung | ohne O-Ring
sealed | without O-ring
étanche | sans joint torique

Verwendung:

Für Werkzeuge mit Steilkegelschaft ISO 7388-1 (ehemals DIN 69871)
Für Werkzeuge mit Steilkegelschaft ISO 7388-2 (ehemals JIS B 6339 MAS-BT)
Passend für „Biesse“ und „Leuco“ Werkzeugmaschinen

Application:

For tools with taper shanks ISO 7388-1 (formerly DIN 69871)
For tools with taper shanks ISO 7388-2 (formerly JIS B 6339 MAS-BT)
Suitable for „Biesse“ and „Leuco“ machine tools

Utilisation:

Pour les outils avec queue conique ISO 7388-1 (l'ancien DIN 69871)
Pour les outils avec queue conique ISO 7388-2 (l'ancien JIS B 6339 MAS-BT)
Convient aux machines-outils „Biesse“ et „Leuco“



K Anzugsbolzen CAT metrisch | Typ „MAZAK“

Pull studs CAT metric | typ „MAZAK“
Tirettes CAT métrique | type „MAZAK“

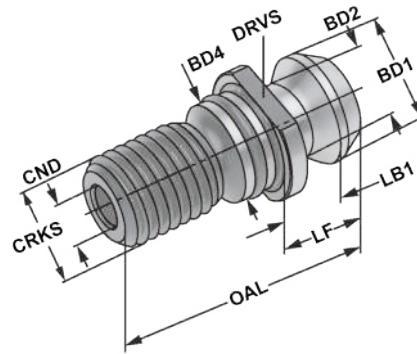

Bestell-Nr. Order no. Référence	CRKS	OAL	LF	LB1	BD1	BD2	BD4	CND	BHTA	DRVS
404.20.16.21	M16	41,26	16,26	11,18	18,80	12,45	17,00	7,0	45°	19

Form UD | mit Durchgangsbohrung | inkl. O-Ring
Form UD | with drill through | incl. O-ring
Forme UD | percée | avec joint torique

504.20.24.21	M24	65,40	25,40	17,80	28,95	20,80	25,00	11,5	45°	30
--------------	-----	-------	-------	-------	-------	-------	-------	------	-----	----

Form UD | mit Durchgangsbohrung | inkl. O-Ring
Form UD | with drill through | incl. O-ring
Forme UD | percée | avec joint torique

Verwendung:
Für Werkzeuge mit Steilkegelschaft ISO 7388-1 (ehemals DIN 69871)
Passend für „MAZAK“ Werkzeugmaschinen

Application:
For tools with taper shanks ISO 7388-1 (formerly DIN 69871)
Suitable for „MAZAK“ machine tools

Utilisation:
Pour les outils avec queue conique ISO 7388-1 (l'ancien DIN 69871)
Convient aux machines-outils „MAZAK“

10



Pull studs CAT metric for high-pressure cooling

Tirettes CAT métrique pour refroidissement sous haute pression

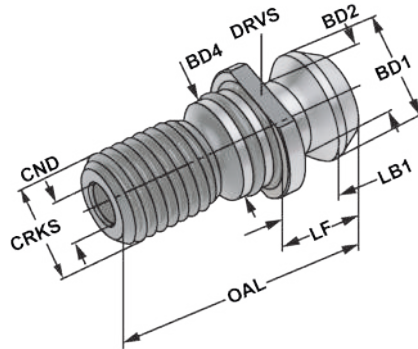

Bestell-Nr. Order no. Référence	CRKS	OAL	LF	LB1	BD1	BD2	BD4	CND	BHTA	DRVS
404.20.16.22	M16	41,26	16,26	11,18	18,80	12,45	17,00	7,0	45°	19
504.20.24.22	M24	65,40	25,40	17,80	28,95	20,80	25,00	11,5	45°	30

Form UD | mit Durchgangsbohrung | inkl. O-Ringen in der Bohrung und am Bund

Form UD | with drill through | incl. O-rings in the bore and the collar

Forme UD | percée | avec joints toriques dans le perçage et à la collerette

Verwendung:

Für Werkzeuge mit Steilkegelschaft ISO 7388-1 (ehemals DIN 69871)

Application:

For tools with taper shanks ISO 7388-1 (formerly DIN 69871)

Utilisation:

Pour les outils avec queue conique ISO 7388-1 (l'ancien DIN 69871)



K Anzugsbolzen ISO 7388-3 | Schaftform JF

ohne Kühlmittel-Zufuhr | ehemals JIS B 6339 (MAS 403 BT)

Pull studs ISO 7388-3 | shank form JF | without cooling lubricant supply | formerly JIS B 6339 (MAS 403 BT)
 Tirettes ISO 7388-3 | forme JF | sans arrosage | l'ancien JIS B 6339 (MAS 403 BT)

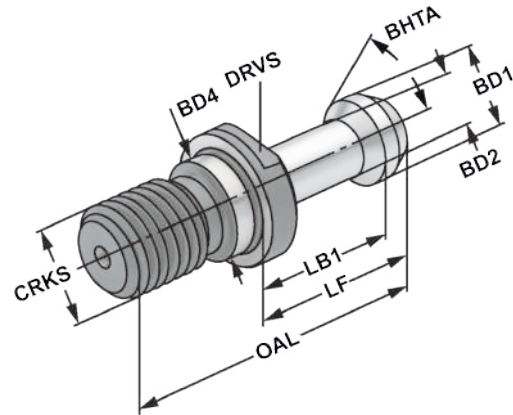

Bestell-Nr. Order no. Référence	CRKS	BHTA	OAL	LF	LB1	BD1	BD2	BD4	CND	DRVS
305.20.45	M12	45°	43	23	18	11	7	12,5	-	13
305.20.60	M12	60°	43	23	18	11	7	12,5	-	13
405.20.45	M16	45°	60	35	28	15	10	17,0	-	19
405.20.60	M16	60°	60	35	28	15	10	17,0	-	19
405.20.90	M16	90°	60	35	28	15	10	17,0	-	19
505.20.45	M24	45°	85	45	35	23	17	25,0	-	30
505.20.60	M24	60°	85	45	35	23	17	25,0	-	30
505.20.90	M24	90°	85	45	35	23	17	25,0	-	30

Form JF | ohne Durchgangsbohrung | ohne O-Ring
 Form JF | sealed | without O-ring
 Forme JF | étanche | sans joint torique

Verwendung:
 Für Werkzeuge mit Steilkegelschaft ISO 7388-2 (ehemals JIS B 6339 MAS-BT)

Application:
 For tools with taper shanks ISO 7388-2 (formerly JIS B 6339 MAS-BT)

Utilisation:
 Pour les outils avec queue conique ISO 7388-2 (l'ancien JIS B 6339 MAS-BT)

10

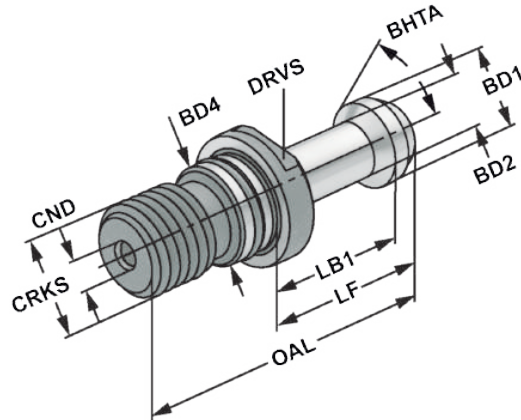

mit zentrischer innerer Kühlmittel-Zufuhr | ehemals JIS B 6339 (MAS 403 BT)

Pull studs ISO 7388-3 | shank form JD | for centric inner cooling lubricant supply | formerly JIS B 6339
Tirettes ISO 7388-3 | forme JD | avec arrosage interne centré | l'ancien JIS B 6339 (MAS 403 BT)

Bestell-Nr. Order no. Référence	CRKS	BHTA	OAL	LF	LB1	BD1	BD2	BD4	CND	DRVS
306.20.45	M12	45°	43	23	18	11	7	12,5	2,5	13
306.20.60	M12	60°	43	23	18	11	7	12,5	2,5	13
406.20.45	M16	45°	60	35	28	15	10	17,0	4,0	19
406.20.60	M16	60°	60	35	28	15	10	17,0	4,0	19
406.20.90	M16	90°	60	35	28	15	10	17,0	4,0	19
506.20.45	M24	45°	85	45	35	23	17	25,0	6,0	30
506.20.60	M24	60°	85	45	35	23	17	25,0	6,0	30
506.20.90	M24	90°	85	45	35	23	17	25,0	6,0	30

Form JD | mit Durchgangsbohrung | inkl. O-Ring
 Form JD | with drill through | incl. O-ring
 Forme JD | percée | avec joint torique

Verwendung:
 Für Werkzeuge mit Steilkegelschaft ISO 7388-2 (ehemals JIS B 6339 MAS-BT)

Application:
 For tools with taper shanks ISO 7388-2 (formerly JIS B 6339 MAS-BT)

Utilisation:
 Pour les outils avec queue conique ISO 7388-2 (l'ancien JIS B 6339 MAS-BT)





Anzugsbolzen ähnlich ISO 7388-3 | Typ „Haas“ | 3 mm verkürzt

Pull studs Haas similar to ISO 7388-3 | Typ „Haas“ | shortened by 3 mm

Tirettes Haas ressemblant à ISO 7388-3 | type „Haas“ | raccourci par 3 mm

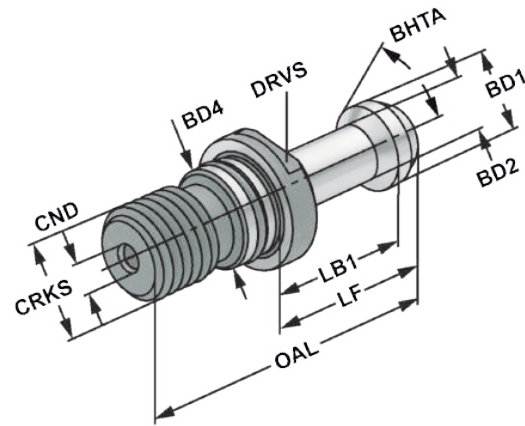

Bestell-Nr. Order no. Référence	CRKS	BHTA	OAL	LF	LB1	BD1	BD2	BD4	CND	DRVS
405.20.45.21	M16	45°	57	32	25	15	10	17	4,0	19
405.20.60.21	M16	60°	57	32	25	15	10	17	4,0	19
405.20.90.21	M16	90°	57	32	25	15	10	17	4,0	19

Form JD | mit Durchgangsbohrung | inkl. O-Ring

Form JD | with drill through | incl. O-ring

Forme JD | percée | avec joint torique



Bestell-Nr. Order no. Référence	CRKS	BHTA	OAL	LF	LB1	BD1	BD2	BD4	CND	DRVS
406.20.45.21	M16	45°	57	32	25	15	10	17	-	19
406.20.60.21	M16	60°	57	32	25	15	10	17	-	19
406.20.90.21	M16	90°	57	32	25	15	10	17	-	19

Form JF | ohne Durchgangsbohrung | inkl. O-Ring

Form JF | sealed | incl. O-ring

Forme JF | étanche | avec joint torique

10

Verwendung:

Für Werkzeuge mit Steilkegelschaft ISO 7388-1 (ehemals DIN 69871)
Passend für „HAAS“, „MICRON“ und „HURCO“ Werkzeugmaschinen

Application:

For tools with taper shanks ISO 7388-1 (formerly DIN 69871)
Suitable for „HAAS“, „MICRON“ and „HURCO“ machine tools

Utilisation:

Pour les outils avec queue conique ISO 7388-1 (l'ancien DIN 69871)
Convient aux machines-outils „HAAS“, „MICRON“ et „HURCO“



Pull studs BT/SK30 for Fanuc Robodrill + Brother + dual contact
Tirettes BT/SK30 pour Fanuc Robodrill + Brother + dual contact

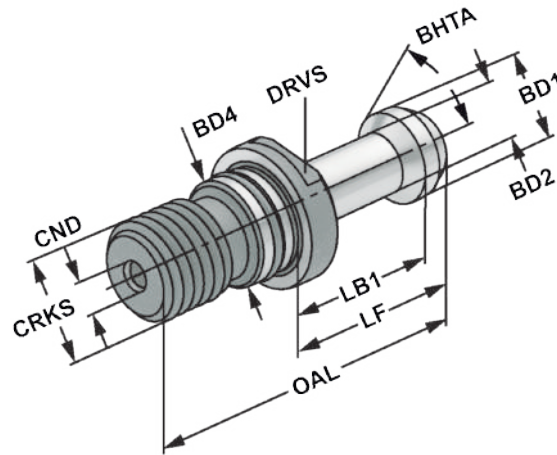

Bestell-Nr. Order no. Référence	CRKS	BHTA	OAL	LF	LB1	BD1	BD2	BD4	CND	DRVS	
305.20.12.25	M12	45°	43,6	23,6	18,6	11	8	13	4,0	13	Fanuc
305.20.12.26*	M12	60°	43	23	18	11	7,5	12,5	2,5	13	Brother
305.20.12.27	M12	45°	43	23	18	11	8	12,5	4,0	13	Dual contact

Form JD | mit Durchgangsbohrung | inkl. O-Ring
Form JD | with drill through | incl. O-ring
Forme JD | percée | avec joint torique

***Form JD | mit Durchgangsbohrung | ohne O-Ring**
*Form JD | with drill through | without O-ring
*Forme JD | percée | sans joint torique

Verwendung:

Für Werkzeuge mit Steilkegelschaft ISO 7388-1 (ehemals DIN 69871)
Für Werkzeuge mit Steilkegelschaft ISO 7388-2 (ehemals JIS B 6339 MAS-BT)
Passend für Werkzeugmaschinen von „Fanuc Robodrill“, „Brother“ und Werkzeugmaschinen mit Plananlage

Application:

For tools with taper shanks ISO 7388-1 (formerly DIN 69871)
For tools with taper shanks ISO 7388-2 (formerly JIS B 6339 MAS-BT)
Suitable for „Fanuc Robodrill“, „Brother“ and „DUAL Contact spindle“ machine tools

Utilisation:

Pour les outils avec queue conique ISO 7388-1 (l'ancien DIN 69871)
Pour les outils avec queue conique ISO 7388-2 (l'ancien JIS B 6339 MAS-BT)
Convient aux machines-outils de „Fanuc Robodrill“, „Brother“ et aux machines-outils avec „Contact direct“



K Anzugsbolzen für Werkzeugaufnahmen nach ISO 7388-1

DIN 2080 mit Ott-Ringnut

Pull studs DIN 2080 with Ott-groove
Tirettes DIN 2080 avec gorge Ott

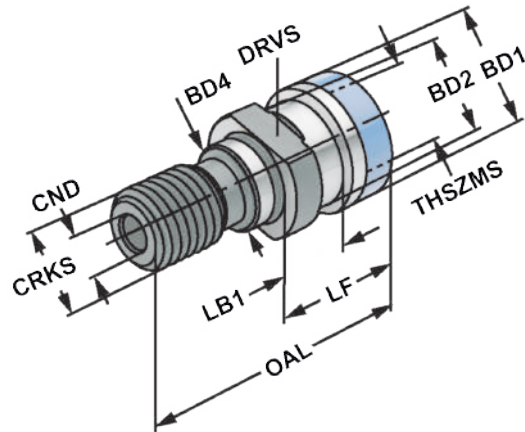

Bestell-Nr. Order no. Référence	CRKS	OAL	LF	LB1	BD1	BD2	BD4	CND	THSZMS	DRVS
401.20.16	M16	53,0	25,1	13,6	25,00	21,1	17	7,0	M16	19
501.20.24	M24	65,1	25,1	13,3	39,60	32,0	25	7,0	M24	30

Mit Innengewinde und Durchgangsbohrung | für Werkzeuge nach ISO 7388-1 zum Umrüsten auf DIN 2080
With internal thread and drill through | For tools according to ISO 7388-1 for conversion to DIN 2080
Avec filetage intérieur et perçage | pour les outils suivant ISO 7388-1 à convertir en DIN 2080

Hinweis: Mit Kantenschutzring
Note: With protection ring
Observation: Avec bague de protection

Sägengewinde DECKEL S 20 x 2

Pull studs for tool holders according to ISO 7388-1 - DECKEL Asymmetrical thread S 20 x 2
 Tirettes pour attachements suivant ISO 7388-1 - DECKEL Fil asymétrique S 20 x 2

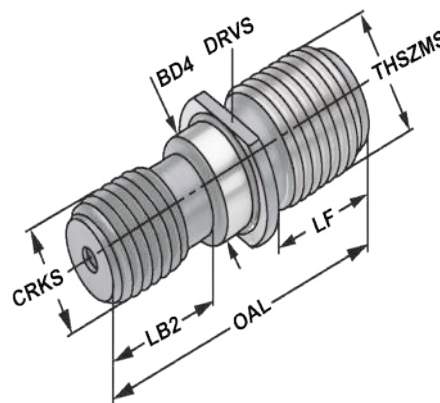

Bestell-Nr. Order no. Référence	CRKS	OAL	LF	LB2	THSZMS	BD4	DRVS
401.20.16.S	M16	54	23	22	S 20 x 2	17,0	19



Schnellwechsel-Einsätze ohne Sicherheitskupplung, Größe 1

Quick change adaptors without safety clutch, size 1

Adaptateurs à changement rapide sans limiteur de couple, taille 1



Verwendung:

Zur Spannung von Gewindebohrern.
Für Rechts- und Linksgewinde. Standardausführung ohne Sicherheitskupplung.

Application:

For mounting taps. For right-hand and left-hand threads. Standard type without safety clutch.

Application:

Pour le serrage de tarauds. Pour taraudage à droite et à gauche. Modèle standard sans limiteur de couple.

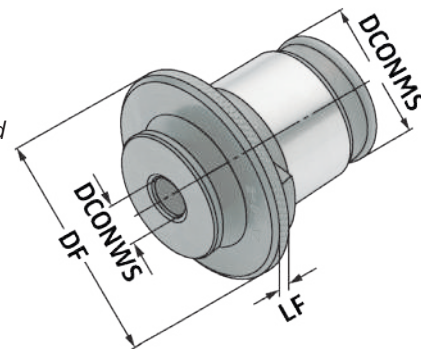

Bestell-Nr. Order no. Référence	SZID	DCONMS	DCONWS	DRVS	DIN371	DIN 374 / 376	DF	LF
16.01.2821	1	19	2,8	2,1	M2-M2,6	-	30	4
16.01.3527	1	19	3,5	2,7	M3	-	30	4
16.01.43	1	19	4,0	3,0	M3,5	-	30	4
16.01.4534	1	19	4,5	3,4	M4	-	30	4
16.01.649	1	19	6,0	4,9	M4,5-M6	M8	30	4
16.01.755	1	19	7,0	5,5	M7	M10	30	4
16.01.862	1	19	8,0	6,2	M8	M11	30	4
16.01.97	1	19	9,0	7,0	M9	M12	30	4
16.01.108	1	19	10,0	8,0	M10	-	30	4
16.01.119	1	19	11,0	9,0	-	M14	30	4



10.48

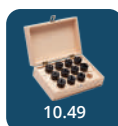

10.49



10.50

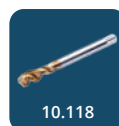

10.118

Quick change adaptors with safety clutch, size 1

Adaptateurs à changement rapide avec limiteur de couple, taille 1



Verwendung:

Zur Spannung von Gewindebohrern.
Für Rechts- und Linksgewinde. Ausführung mit einstellbarer Sicherheitskupplung zur Vermeidung von Gewindebohrerbruch.

Application:

For mounting taps. For right-hand and left-hand threads. Type with adjustable safety clutch, which prevents the breaking of taps.

Application:

Pour le serrage de tarauds. Pour taraudage à droite et à gauche. Modèle avec limiteur de couple, qui prévient la casse des tarauds.

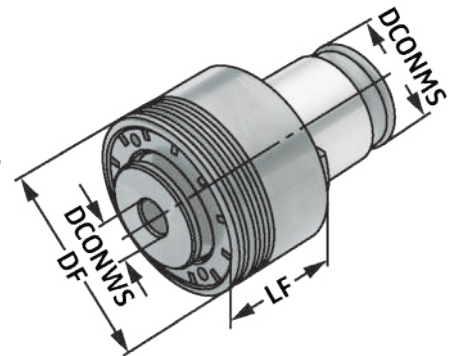

Bestell-Nr. Order no. Référence	SZID	DCONMS	DCONWS	DRVS	DIN371	DIN 374 / 376	DF	LF
16.11.228	1	19	2,8	2,1	M2	-	32	25
16.11.2528	1	19	2,8	2,1	M2,5	-	32	25
16.11.335	1	19	3,5	2,7	M3	-	32	25
16.11.354	1	19	4,0	3,0	M3,5	-	32	25
16.11.445	1	19	4,5	3,4	M4	-	32	25
16.11.5649	1	19	6,0	4,9	M5	-	32	25
16.11.6649	1	19	6,0	4,9	M6	-	32	25
16.11.107	1	19	7,0	5,5	M7	-	32	25
16.11.88	1	19	8,0	6,2	M8	-	32	25
16.11.129	1	19	9,0	7,0	-	M12	32	25
16.11.1010	1	19	10,0	8,0	M10	-	32	25
16.11.14119	1	19	11,0	9,0	-	M14	32	25

Hinweis: Bei Adaptern mit Sicherheitskupplung wird das Drehmoment entsprechend der Gewindegröße vor Auslieferung eingestellt.

Note: Quick change adaptors with safety clutch are supplied with a predefined torque, corresponding to the sizes of the threads.

Observation: Les adaptateurs porte-tarauds à changement rapide avec limiteur de couple sont fournis avec un couple pré-réglé, qui correspond aux tailles de filetages.

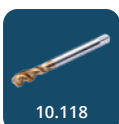
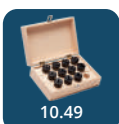



Schnellwechsel-Einsätze ohne Sicherheitskupplung, Größe 2

Quick change adaptors without safety clutch, size 2

Adaptateurs à changement rapide sans limiteur de couple, taille 2



Verwendung:

Zur Spannung von Gewindebohrern.
Für Rechts- und Linksgewinde. Standardausführung ohne Sicherheitskupplung.

Application:

For mounting taps. For right-hand and left-hand threads. Standard type without safety clutch.

Application:

Pour le serrage de tarauds. Pour taraudage à droite et à gauche. Modèle standard sans limiteur de couple.

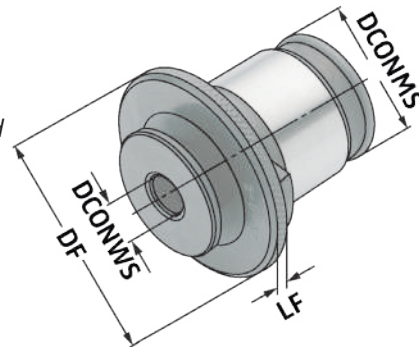

Bestell-Nr. Order no. Référence	SZID	DCONMS	DCONWS	DRVS	DIN371	DIN 374 / 376	DF	LF
16.02.649	2	31	6	4,9	M4,5-M6	-	48	5
16.02.755	2	31	7	5,5	M7	-	48	5
16.02.862	2	31	8	6,2	M8	-	48	5
16.02.97	2	31	9	7,0	M9	-	48	5
16.02.108	2	31	10	8,0	M10	-	48	5
16.02.119	2	31	11	9,0	-	M14	48	5
16.02.129	2	31	12	9,0	-	M16	48	5
16.02.1411	2	31	14	11,0	-	M18	48	5
16.02.1612	2	31	16	12,0	-	M20	48	5
16.02.18145	2	31	18	14,5	-	M22-M24	48	5



10.48



10.49



10.50

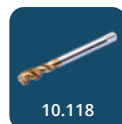

10.118

Quick change adaptors with safety clutch, size 2

Adaptateurs à changement rapide avec limiteur de couple, taille 2



Verwendung:

Zur Spannung von Gewindebohrern.
Für Rechts- und Linksgewinde. Ausführung mit einstellbarer Sicherheitskupplung zur Vermeidung von Gewindebohrerbruch.

Application:

For mounting taps. For right-hand and left-hand threads. Type with adjustable safety clutch, which prevents the breaking of taps.

Application:

Pour le serrage de tarauds. Pour taraudage à droite et à gauche. Modèle avec limiteur de couple, qui prévient la casse des tarauds.

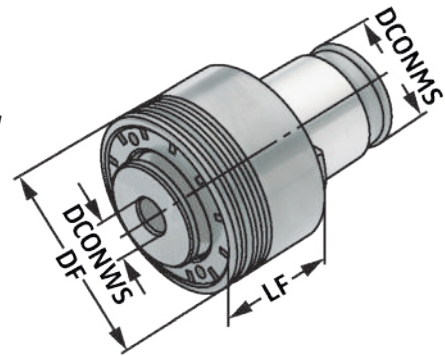

Bestell-Nr. Order no. Référence	SZID	DCONMS	DCONWS	DRVS	DIN371	DIN 374 / 376	DF	LF
16.12.5649	2	31	6	4,9	M5	-	50	31
16.12.6649	2	31	6	4,9	M6	-	50	31
16.12.88	2	31	8	6,2	M8	-	50	31
16.12.107	2	31	7	5,5	-	M10	50	31
16.12.129	2	31	9	7,0	-	M12	50	31
16.12.1010	2	31	10	8,0	M10	-	50	31
16.12.1411	2	31	11	9,0	-	M14	50	31
16.12.1612	2	31	12	9,0	-	M16	50	31
16.12.181411	2	31	14	11,0	-	M18	50	31
16.12.2016	2	31	16	12,0	-	M20	50	31
16.12.2218145	2	31	18	14,5	-	M22	50	31

Hinweis:

Bei Adaptern mit Sicherheitskupplung wird das Drehmoment entsprechend der Gewindegröße vor Auslieferung eingestellt.

Note:

Quick change adaptors with safety clutch are supplied with a predefined torque, corresponding to the sizes of the threads.

Observation:

Les adaptateurs porte-tarauds à changement rapide avec limiteur de couple sont fournis avec un couple pré-réglé, qui correspond aux tailles de filetages.



K Schnellwechsel-Einsätze ohne Sicherheitskupplung, Größe 3

Quick change adaptors without safety clutch, size 3
Adaptateurs à changement rapide sans limiteur de couple, taille 3



Verwendung:

Zur Spannung von Gewindebohrern.
Für Rechts- und Linksgewinde. Standardausführung ohne Sicherheitskupplung.

Application:

For mounting taps. For right-hand and left-hand threads. Standard type without safety clutch.

Application:

Pour le serrage de tarauds. Pour taraudage à droite et à gauche. Modèle standard sans limiteur de couple.

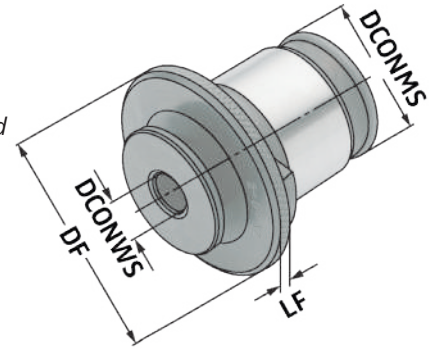

Bestell-Nr. Order no. Référence	SZID	DCONMS	DCONWS	DRVS	DIN371	DIN 374 / 376	DF	LF
16.03.119	3	48	11	9,0	-	M14	70	6
16.03.129	3	48	12	9,0	-	M16	70	6
16.03.1411	3	48	14	11,0	-	M18	70	6
16.03.1612	3	48	16	12,0	-	M20	70	6
16.03.18145	3	48	18	14,5	-	M22-M24	70	6
16.03.2016	3	48	20	16,0	-	M27	70	6
16.03.2218	3	48	22	18,0	-	M30	70	6
16.03.2520	3	48	25	20,0	-	M33	70	6
16.03.2822	3	48	28	22,0	-	M36	70	6

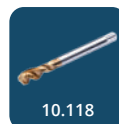
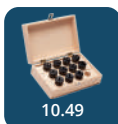

Quick change adaptors with safety clutch, size 3

Adaptateurs à changement rapide avec limiteur de couple, taille 3



Verwendung:

Zur Spannung von Gewindebohrern.
Für Rechts- und Linksgewinde. Ausführung mit einstellbarer Sicherheitskupplung zur Vermeidung von Gewindebohrerbruch.

Application:

For mounting taps. For right-hand and left-hand threads. Type with adjustable safety clutch, which prevents the breaking of taps.

Application:

Pour le serrage de tarauds. Pour taraudage à droite et à gauche. Modèle avec limiteur de couple, qui prévient la casse des tarauds.

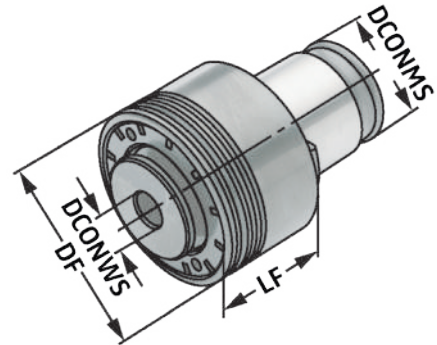

Bestell-Nr. Order no. Référence	SZID	DCONMS	DCONWS	DRVS	DIN371	DIN 374 / 376	DF	LF
16.13.14119	3	48	11	9,0	-	M14	72	41
16.13.16129	3	48	12	9,0	-	M16	72	41
16.13.181411	3	48	14	11,0	-	M18	72	41
16.13.201612	3	48	16	12,0	-	M20	72	41
16.13.2218145	3	48	18	14,5	-	M22	72	41
16.13.2418145	3	48	18	14,5	-	M24	72	41
16.13.272016	3	48	20	16,0	-	M27	72	41
16.13.302218	3	48	22	18,0	-	M30	72	41
16.13.332520	3	48	25	20,0	-	M33	72	41
16.13.362822	3	48	28	22,0	-	M36	72	41

Hinweis:

Bei Adaptern mit Sicherheitskupplung wird das Drehmoment entsprechend der Gewindegröße vor Auslieferung eingestellt.

Note:

Quick change adaptors with safety clutch are supplied with a predefined torque, corresponding to the sizes of the threads.

Observation:

Les adaptateurs porte-tarauds à changement rapide avec limiteur de couple sont fournis avec un couple pré-régulé, qui correspond aux tailles de filetages.

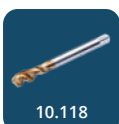
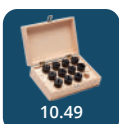

K Reduzieradapter für Schnellwechsel-Einsätze

Reducing adaptors for quick change adaptors
Réductions pour adaptateurs à changement rapide



Verwendung:
Reduzieradapter zum Reduzieren der Größen 3 auf 2 bzw. 2 auf 1. Hiermit können die Spannbereiche nach unten erweitert werden.

Application:
Reducing adaptor for reducing size 3 to 2 and 2 to 1. In this way the clamping ranges can be extended to smaller sizes.

Application:
Pour la réduction des tailles 3 à 2 et 2 à 1. Il est ainsi possible d'élargir la plage inférieure de serrage.

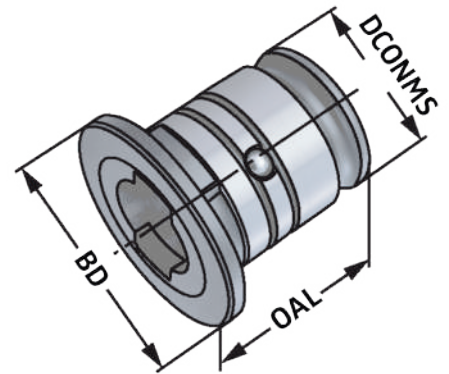

Bestell-Nr. Order no. Référence	Aufnahme workholder logement	Einsatz adaptor adapt.	BD	DCONMS	OAL
16.00.0201	2	1	48	31	40,4
16.00.0302	3	2	59	48	62,6

Holzkästen, leer

Wooden boxes, empty
Coffrets en bois, vides



Verwendung:
Zur Aufbewahrung von Gewindegewinde-schneidfutter Schnellwechsel-Einsätzen.

Application:
For the storage of tapping quick change adaptors.

Application:
Pour la conservation adaptateurs à changement rapide.

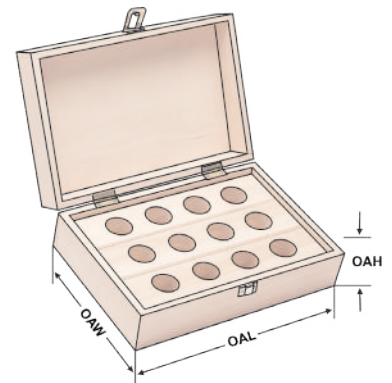

Bestell-Nr. Order no. Référence	Abmessung Size Dimension	Bohrungen Holes Trous	OAL	OAW	OAH
701.G01	Gr. 1	12	360	235	70
701.G02	Gr. 2	12	360	235	70
701.G03	Gr. 3	10	360	235	70

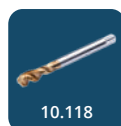
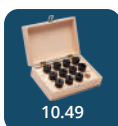

Quick change adaptors for tapping chucks in wooden box

Adaptateurs à changement rapide pour mandrins de taraudage dans coffret en bois



Verwendung:

Zur Spannung von Gewindebohrern.
Für Rechts- und Linksgewinde. Ausführung mit einstellbarer Sicherheitskupplung zur Vermeidung von Gewindebohrerbruch.

Application:

For mounting taps. For right-hand and left-hand threads. Type with adjustable safety clutch, which prevents the breaking of taps.

Application:

Pour le serrage de tarauds. Pour taraudage à droite et à gauche. Modèle avec limiteur de couple, qui prévient la casse des tarauds.



Bestell-Nr. Order no. Référence	Abmessung Size Dimension	OAL	OAW	OAH
701.16.01-S	9 Einsätze - Gr. 1 Ohne Rutschkupplung without clutch sans limiteur de couple 3,5x2,7 - 4x3 - 4,5x3,4 - 6x4,9 - 7x5,5 - 8x6,2 - 9x7 - 10x8 - 11x9	360	235	70
701.16.02-S	10 Einsätze - Gr. 2 Ohne Rutschkupplung without clutch sans limiteur de couple 6x4,9 - 7x5,5 - 8x6,2 - 9x7 - 10x8 - 11x9 - 12x9 - 14x11 - 16x12 - 18x14,5	360	235	70
701.16.03-S	9 Einsätze - Gr. 3 Ohne Rutschkupplung without clutch sans limiteur de couple 11x9 - 12x9 - 14x11 - 16x12 - 18x14,5 - 20x16 - 22x18 - 25x20 - 28x22	360	235	70
701.16.11-S	10 Einsätze - Gr. 1 - M3/M14 Mit Rutschkupplung with clutch avec limiteur de couple M3 - M3,5 - M4 - M5 - M6 - M8 - M10 - M10 - M12 - M14	360	235	70
701.16.12-S	11 Einsätze - Gr. 2 - M5/M22 Mit Rutschkupplung with clutch avec limiteur de couple M5 - M6 - M8 - M10 - M10 - M12 - M14 - M16 - M18 - M20 - M22	360	235	70
701.16.13-S	10 Einsätze - Gr. 3 - M14/M36 Mit Rutschkupplung with clutch avec limiteur de couple M14 - M16 - M18 - M20 - M22 - M24 - M27 - M30 - M33 - M36	360	235	70



Gewindeschneid-Schnellwechselfutter mit Längenausgleich auf Druck und Zug für Zylinderschäfte DIN 1835 B+E

Quick change tapping chucks with length compensation on compression and expansion for tool shanks DIN 1835 B+E

Mandrins de taraudage à changement rapide avec compensation longitudinale à la compression et traction pour queues cylindriques DIN 1835 B+E



Verwendung:
Zur Aufnahme von Schnellwechsel-Ein-sätzen für Gewindebohrer.

Application:
For the chucking of Quick change taps for threading taps.

Application:
Pour le serrage d'adaptateurs porte-tarauts à changement rapide.

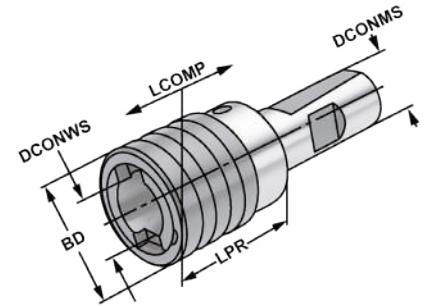

Bestell-Nr. Order no. Référence	DCONMS	Spannbereich Capacity Capacité	SZID	LPR	BD	DCONWS	LCOMP
120.16.2012	20	M3 – M14	1	43	36	19	7
120.16.2020	20	M5 – M22	2	73	53	31	12
120.16.2512	25	M3 – M14	1	43	36	19	7
120.16.2520	25	M5 – M22	2	73	53	31	12
120.16.3220	32	M5 – M22	2	73	53	31	12

Hinweis: Für Bearbeitungszentren ohne Synchronspindel.
Note: On machining centres without synchronised spindles.
Observation: Sur centres d'usinage sans axe synchrone.

Ausführung: Mit seitlicher Spannfläche nach DIN 1835 Form B (Weldon) und DIN 1835 Form E (Whistle Notch).

Version: With flat according to DIN 1835 form B (Weldon) and inclined flat according to DIN 1835 form E (Whistle Notch).

Version: Avec queue cylindrique et avec méplat suivant DIN 1835 forme B (Weldon) et avec méplat incliné suivant DIN 1835 forme E (Whistle Notch).



für Spannzangen ISO 15488 (DIN 6499) System ER

Tapping chucks for synchronisation with tool shanks DIN 1835 B+E for collets ISO 15488 (DIN 6499) ER-system

Mandrins de taraudage pour synchronisation avec queues cylindriques DIN 1835 B+E pour pinces ISO 15488 (DIN 6499) système ER



Verwendung:
Für Bearbeitungszentren mit Synchronspindel.

Application:
For machining centres with synchronous spindle.

Application:
Pour centres d'usinage avec broche synchrone.

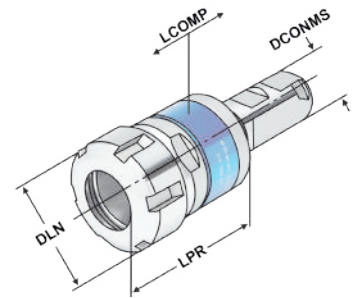

Bestell-Nr. Order no. Référence	DCONMS	DCONWS Spannbereich Capacity Capacité	Typ	LPR	DLN	LCOMP	DRVS
120.16.2016	20	M3 – M10	426E ER 16 Mini	58	22	0,5	-
120.16.2025	20	M3 – M20	430E ER 25	63	42	0,5	28
120.16.2516	25	M3 – M10	426E ER 16 Mini	58	22	0,5	-
120.16.2525	25	M3 – M20	430E ER 25	63	42	0,5	28
120.16.2532	25	M4 – M27	470E ER 32	69	50	0,5	42
120.16.2540	25	M4 – M33	472E ER 40	109	63	0,5	55
120.16.3232	32	M4 – M27	470E ER 32	69	50	0,5	42
120.16.3240	32	M4 – M33	472E ER 40	109	63	0,5	55

Hinweis:

- Synchro-Gewindeschneidfutter kompensieren Synchronisationsfehler
- Minimallängenausgleich in Druck- und Zugrichtung zwischen Synchronspindel und Gewindebohrer reduziert zu hohe Gewindeflankenreibungskräfte.
- Reduziert eventuelle Axialkraftherhöhung während des Schneidzyklus auf ein Minimum.

Note:

- *Synchro tapping chucks compensate synchronisation errors*
- *Minimal length compensation on compression and expansion balances very small pitch differences between synchro spindle and tap, which can cause high frictional forces on the thread flanks.*
- *A possible increase of axial force during the tapping process is reduced to a minimum.*

Observation:

- Mandrins de taraudage version „synchro“ compensent les erreurs éventuelles de synchronisation
- Compensation longitudinale minimale à la compression et traction entre la broche synchronisée et le taraud réduit la friction au niveau des flancs de filets.
- Réduit au minimum les efforts éventuelles axiaux lors du cycle de taraudage.

Lieferumfang:

Mit gewuchteter Spannmutter

Delivery:

With balanced clamping nut

Livraison:

Avec écrou de serrage équilibré





Gewindeschneid-Schnellwechselfutter DIN 69871 A mit Längenausgleich auf Druck und Zug im Holzkasten inkl. Einsätze mit Rutschkupplung

Quick-change tapping chucks DIN 69871 A with length compensation in a wooden box incl. tapping collets with clutch

Mandrin de taraudage DIN 69871 A avec compensation longitudinale dans coffret en bois incl. douilles avec limiteur de couple

Bestell Nr. <i>Order no. / Réf.</i>	Abmessung <i>Size / Dimension</i>	Größe <i>Size / Taille</i>	Stück <i>Pcs.</i>
402.16.12.SR	SK 40 - M3 / M14	Gr. 1	8
402.16.20.SR	SK 40 - M5 / M22	Gr. 2	10
502.16.12.SR	SK 50 - M3 / M14	Gr. 1	8
502.16.20.SR	SK 50 - M5 / M22	Gr. 2	10



Gewindeschneid-Schnellwechselfutter DIN 69871 A mit Längenausgleich auf Druck und Zug im Holzkasten inkl. Einsätze ohne Rutschkupplung

Quick-change tapping chucks DIN 69871 A with length compensation in a wooden box incl. tapping collets without clutch

Mandrin de taraudage DIN 69871 A avec compensation longitudinale dans coffret en bois incl. douilles sans limiteur de couple

Bestell Nr. <i>Order no. / Réf.</i>	Abmessung <i>Size / Dimension</i>	Größe <i>Size / Taille</i>	Stück <i>Pcs.</i>
402.16.12.S	SK 40 - M3 / M14	Gr. 1	7
402.16.20.S	SK 40 - M5 / M22	Gr. 2	9
502.16.12.S	SK 50 - M3 / M14	Gr. 1	7
502.16.20.S	SK 50 - M5 / M22	Gr. 2	9

10



Einsätze mit Rutschkupplung

Tapping collets with clutch
Douilles avec limiteur de couple

Abmessung <i>Size / Dimension</i>	Abmessung <i>Size / Dimension</i>
Gr. 1 M3 - 3,5 × 2,7 DIN 371	Gr. 2 M5 - 6 × 4,9 DIN 371
Gr. 1 M4 - 4,5 × 3,4 DIN 371	Gr. 2 M6 - 6 × 4,9 DIN 371
Gr. 1 M5 - 6 × 4,9 DIN 371	Gr. 2 M8 - 8 × 6,2 DIN 371
Gr. 1 M6 - 6 × 4,9 DIN 371	Gr. 2 M10 - 10 × 8 DIN 371
Gr. 1 M8 - 8 × 6,2 DIN 371	Gr. 2 M12 - 9 × 7 DIN 376
Gr. 1 M10 - 10 × 8 DIN 371	Gr. 2 M14 - 11 × 9 DIN 376
Gr. 1 M12 - 9 × 7 DIN 376	Gr. 2 M16 - 12 × 9 DIN 376
Gr. 1 M14 - 11 × 9 DIN 376	Gr. 2 M18 - 14 × 11 DIN 376
	Gr. 2 M20 - 16 × 12 DIN 376
	Gr. 2 M22 - 18 × 14,5 DIN 376



Einsätze ohne Rutschkupplung

Tapping collets without clutch
Douilles sans limiteur de couple

Abmessung <i>Size / Dimension</i>	Abmessung <i>Size / Dimension</i>
Gr. 1 3,5 × 2,7	Gr. 2 6 × 4,9
Gr. 1 4,5 × 3,4	Gr. 2 8 × 6,2
Gr. 1 6 × 4,9	Gr. 2 9 × 7
Gr. 1 8 × 6,2	Gr. 2 10 × 8
Gr. 1 9 × 7	Gr. 2 11 × 9
Gr. 1 10 × 8	Gr. 2 12 × 9
Gr. 1 11 × 9	Gr. 2 14 × 11
	Gr. 2 16 × 12
	Gr. 2 18 × 14,5



Gewindeschneid-Schnellwechselfutter MAS/BT (JIS B 6339) mit Längenausgleich auf Druck und Zug im Holzkasten inkl. Einsätze mit Rutschkupplung

Quick-change tapping chucks MAS/BT (JIS B 6339) with length compensation in a wooden box incl. tapping collets with clutch
 Mandrin de taraudage MAS/BT (JIS B 6339) avec compensation longitudinale dans coffret en bois incl. douilles avec limiteur de couple

Bestell Nr. <i>Order no. / Réf.</i>	Abmessung <i>Size / Dimension</i>	Größe <i>Size / Taille</i>	Stück <i>Pcs.</i>
405.16.12.SR	BT 40 - M3 / M14	Gr. 1	8
405.16.20.SR	BT 40 - M5 / M22	Gr. 2	10
505.16.12.SR	BT 50 - M3 / M14	Gr. 1	8
505.16.20.SR	BT 50 - M5 / M22	Gr. 2	10



Gewindeschneid-Schnellwechselfutter MAS/BT (JIS B 6339) mit Längenausgleich auf Druck und Zug im Holzkasten inkl. Einsätze ohne Rutschkupplung

Quick-change tapping chucks MAS/BT (JIS B 6339) with length compensation in a wooden box incl. tapping collets without clutch
 Mandrin de taraudage MAS/BT (JIS B 6339) avec compensation longitudinale dans coffret en bois incl. douilles sans limiteur de couple

Bestell Nr. <i>Order no. / Réf.</i>	Abmessung <i>Size / Dimension</i>	Größe <i>Size / Taille</i>	Stück <i>Pcs.</i>
405.16.12.S	BT 40 - M3 / M14	Gr. 1	7
405.16.20.S	BT 40 - M5 / M22	Gr. 2	9
505.16.12.S	BT 50 - M3 / M14	Gr. 1	7
505.16.20.S	BT 50 - M5 / M22	Gr. 2	9



Einsätze mit Rutschkupplung

Tapping collets with clutch
 Douilles avec limiteur de couple

Abmessung <i>Size / Dimension</i>	Abmessung <i>Size / Dimension</i>
Gr. 1 M3 - 3,5 × 2,7 DIN 371	Gr. 2 M5 - 6 × 4,9 DIN 371
Gr. 1 M4 - 4,5 × 3,4 DIN 371	Gr. 2 M6 - 6 × 4,9 DIN 371
Gr. 1 M5 - 6 × 4,9 DIN 371	Gr. 2 M8 - 8 × 6,2 DIN 371
Gr. 1 M6 - 6 × 4,9 DIN 371	Gr. 2 M10 - 10 × 8 DIN 371
Gr. 1 M8 - 8 × 6,2 DIN 371	Gr. 2 M12 - 9 × 7 DIN 376
Gr. 1 M10 - 10 × 8 DIN 371	Gr. 2 M14 - 11 × 9 DIN 376
Gr. 1 M12 - 9 × 7 DIN 376	Gr. 2 M16 - 12 × 9 DIN 376
Gr. 1 M14 - 11 × 9 DIN 376	Gr. 2 M18 - 14 × 11 DIN 376
	Gr. 2 M20 - 16 × 12 DIN 376
	Gr. 2 M22 - 18 × 14,5 DIN 376



Einsätze ohne Rutschkupplung

Tapping collets without clutch
 Douilles sans limiteur de couple

Abmessung <i>Size / Dimension</i>	Abmessung <i>Size / Dimension</i>
Gr. 1 3,5 × 2,7	Gr. 2 6 × 4,9
Gr. 1 4,5 × 3,4	Gr. 2 8 × 6,2
Gr. 1 6 × 4,9	Gr. 2 9 × 7
Gr. 1 8 × 6,2	Gr. 2 10 × 8
Gr. 1 9 × 7	Gr. 2 11 × 9
Gr. 1 10 × 8	Gr. 2 12 × 9
Gr. 1 11 × 9	Gr. 2 14 × 11
	Gr. 2 16 × 12
	Gr. 2 18 × 14,5



Gewindeschneid-Schnellwechselfutter DIN 69893 A mit Längenausgleich auf Druck und Zug im Holzkasten inkl. Einsätze mit Rutschkupplung

Quick-change tapping chucks DIN 69893 A with length compensation in a wooden box incl. tapping collets with clutch

Mandrin de taraudage DIN 69893 A avec compensation longitudinale dans coffret en bois incl. douilles avec limiteur de couple

Bestell Nr. Order no. / Réf.	Abmessung Size / Dimension	Größe Size / Taille	Stück Pcs.
A63.16.12.SR	HSK 63 - M3 / M14	Gr. 1	8
A63.16.20.SR	HSK 63 - M5 / M22	Gr. 2	10
A100.16.12.SR	HSK 100 - M3 / M14	Gr. 1	8
A100.16.20.SR	HSK 100 - M5 / M22	Gr. 2	10



Gewindeschneid-Schnellwechselfutter DIN 69893 A mit Längenausgleich auf Druck und Zug im Holzkasten inkl. Einsätze ohne Rutschkupplung

Quick-change tapping chucks DIN 69893 A with length compensation in a wooden box incl. tapping collets without clutch

Mandrin de taraudage DIN 69893 A avec compensation longitudinale dans coffret en bois incl. douilles sans limiteur de couple

Bestell Nr. Order no. / Réf.	Abmessung Size / Dimension	Größe Size / Taille	Stück Pcs.
A63.16.12.S	HSK 63 - M3 / M14	Gr. 1	7
A63.16.20.S	HSK 63 - M5 / M22	Gr. 2	9
A100.16.12.S	HSK 100 - M3 / M14	Gr. 1	7
A100.16.20.S	HSK 100 - M5 / M22	Gr. 2	9

10



Einsätze mit Rutschkupplung

Tapping collets with clutch
Douilles avec limiteur de couple

Abmessung Size / Dimension	Abmessung Size / Dimension
Gr. 1 M3 - 3,5 × 2,7 DIN 371	Gr. 2 M5 - 6 × 4,9 DIN 371
Gr. 1 M4 - 4,5 × 3,4 DIN 371	Gr. 2 M6 - 6 × 4,9 DIN 371
Gr. 1 M5 - 6 × 4,9 DIN 371	Gr. 2 M8 - 8 × 6,2 DIN 371
Gr. 1 M6 - 6 × 4,9 DIN 371	Gr. 2 M10 - 10 × 8 DIN 371
Gr. 1 M8 - 8 × 6,2 DIN 371	Gr. 2 M12 - 9 × 7 DIN 376
Gr. 1 M10 - 10 × 8 DIN 371	Gr. 2 M14 - 11 × 9 DIN 376
Gr. 1 M12 - 9 × 7 DIN 376	Gr. 2 M16 - 12 × 9 DIN 376
Gr. 1 M14 - 11 × 9 DIN 376	Gr. 2 M18 - 14 × 11 DIN 376
	Gr. 2 M20 - 16 × 12 DIN 376
	Gr. 2 M22 - 18 × 14,5 DIN 376



Einsätze ohne Rutschkupplung

Tapping collets without clutch
Douilles sans limiteur de couple

Abmessung Size / Dimension	Abmessung Size / Dimension
Gr. 1 3,5 × 2,7	Gr. 2 6 × 4,9
Gr. 1 4,5 × 3,4	Gr. 2 8 × 6,2
Gr. 1 6 × 4,9	Gr. 2 9 × 7
Gr. 1 8 × 6,2	Gr. 2 10 × 8
Gr. 1 9 × 7	Gr. 2 11 × 9
Gr. 1 10 × 8	Gr. 2 12 × 9
Gr. 1 11 × 9	Gr. 2 14 × 11
	Gr. 2 16 × 12
	Gr. 2 18 × 14,5



Gewindeschneid-Schnellwechselfutter DIN 69880 mit Längenausgleich auf Druck und Zug im Holzkasten inkl. Einsätze mit Rutschkupplung

*Quick-change tapping chucks DIN 69880 with length compensation
in a wooden box incl. tapping collets with clutch*

Mandrin de taraudage DIN 69880 avec compensation longitudinale
dans coffret en bois incl. douilles avec limiteur de couple

Bestell Nr. <i>Order no. / Réf.</i>	Abmessung <i>Size / Dimension</i>	Größe <i>Size / Taille</i>	Stück <i>Pcs.</i>
309.16.12.SR	VDI 30 - M3 / M14	Gr. 1	8
309.16.20.SR	VDI 30 - M5 / M22	Gr. 2	10
409.16.12.SR	VDI 40 - M3 / M14	Gr. 1	8
409.16.20.SR	VDI 40 - M5 / M22	Gr. 2	10



Gewindeschneid-Schnellwechselfutter DIN 69880 mit Längenausgleich auf Druck und Zug im Holzkasten inkl. Einsätze ohne Rutschkupplung

*Quick-change tapping chucks DIN 69880 with length compensation in a
wooden box incl. tapping collets without clutch*

Mandrin de taraudage DIN 69880 avec compensation longitudinale
dans coffret en bois incl. douilles sans limiteur de couple

Bestell Nr. <i>Order no. / Réf.</i>	Abmessung <i>Size / Dimension</i>	Größe <i>Size / Taille</i>	Stück <i>Pcs.</i>
309.16.12.S	VDI 30 - M3 / M14	Gr. 1	7
309.16.20.S	VDI 30 - M5 / M22	Gr. 2	9
409.16.12.S	VDI 40 - M3 / M14	Gr. 1	7
409.16.20.S	VDI 40 - M5 / M22	Gr. 2	9



Einsätze mit Rutschkupplung

Tapping collets with clutch
Douilles avec limiteur de couple

Abmessung <i>Size / Dimension</i>	Abmessung <i>Size / Dimension</i>
Gr. 1 M3 - 3,5 × 2,7 DIN 371	Gr. 2 M5 - 6 × 4,9 DIN 371
Gr. 1 M4 - 4,5 × 3,4 DIN 371	Gr. 2 M6 - 6 × 4,9 DIN 371
Gr. 1 M5 - 6 × 4,9 DIN 371	Gr. 2 M8 - 8 × 6,2 DIN 371
Gr. 1 M6 - 6 × 4,9 DIN 371	Gr. 2 M10 - 10 × 8 DIN 371
Gr. 1 M8 - 8 × 6,2 DIN 371	Gr. 2 M12 - 9 × 7 DIN 376
Gr. 1 M10 - 10 × 8 DIN 371	Gr. 2 M14 - 11 × 9 DIN 376
Gr. 1 M12 - 9 × 7 DIN 376	Gr. 2 M16 - 12 × 9 DIN 376
Gr. 1 M14 - 11 × 9 DIN 376	Gr. 2 M18 - 14 × 11 DIN 376
	Gr. 2 M20 - 16 × 12 DIN 376
	Gr. 2 M22 - 18 × 14,5 DIN 376



Einsätze ohne Rutschkupplung

Tapping collets without clutch
Douilles sans limiteur de couple

Abmessung <i>Size / Dimension</i>	Abmessung <i>Size / Dimension</i>
Gr. 1 3,5 × 2,7	Gr. 2 6 × 4,9
Gr. 1 4,5 × 3,4	Gr. 2 8 × 6,2
Gr. 1 6 × 4,9	Gr. 2 9 × 7
Gr. 1 8 × 6,2	Gr. 2 10 × 8
Gr. 1 9 × 7	Gr. 2 11 × 9
Gr. 1 10 × 8	Gr. 2 12 × 9
Gr. 1 11 × 9	Gr. 2 14 × 11
	Gr. 2 16 × 12
	Gr. 2 18 × 14,5



Gewindeschneid-Schnellwechselfutter DIN 228-1B mit Längenausgleich auf Druck und Zug im Holzkasten inkl. Einsätze mit Rutschkupplung

Quick-change tapping chucks DIN 228-1B with length compensation in a wooden box incl. tapping collets with clutch

Mandrin de taraudage DIN 228-1B avec compensation longitudinale dans coffret en bois incl. douilles avec limiteur de couple

Bestell Nr. Order no. / Réf.	Abmessung Size / Dimension	Größe Size / Taille	Stück Pcs.
107.16.212.SR	MK 2 - M3 / M14	Gr. 1	8
107.16.320.SR	MK 3 - M5 / M22	Gr. 2	10



Gewindeschneid-Schnellwechselfutter DIN 228-1B mit Längenausgleich auf Druck und Zug im Holzkasten inkl. Einsätze ohne Rutschkupplung

Quick-change tapping chucks DIN 228-1B with length compensation in a wooden box incl. tapping collets without clutch

Mandrin de taraudage DIN 228-1B avec compensation longitudinale dans coffret en bois incl. douilles sans limiteur de couple

Bestell Nr. Order no. / Réf.	Abmessung Size / Dimension	Größe Size / Taille	Stück Pcs.
107.16.212.S	MK 2- M3 / M14	Gr. 1	7
107.16.320.S	MK 3 - M5 / M22	Gr. 2	9

10



Einsätze mit Rutschkupplung

Tapping collets with clutch
Douilles avec limiteur de couple

Abmessung Size / Dimension	Abmessung Size / Dimension
Gr. 1 M3 - 3,5 × 2,7 DIN 371	Gr. 2 M5 - 6 × 4,9 DIN 371
Gr. 1 M4 - 4,5 × 3,4 DIN 371	Gr. 2 M6 - 6 × 4,9 DIN 371
Gr. 1 M5 - 6 × 4,9 DIN 371	Gr. 2 M8 - 8 × 6,2 DIN 371
Gr. 1 M6 - 6 × 4,9 DIN 371	Gr. 2 M10 - 10 × 8 DIN 371
Gr. 1 M8 - 8 × 6,2 DIN 371	Gr. 2 M12 - 9 × 7 DIN 376
Gr. 1 M10 - 10 × 8 DIN 371	Gr. 2 M14 - 11 × 9 DIN 376
Gr. 1 M12 - 9 × 7 DIN 376	Gr. 2 M16 - 12 × 9 DIN 376
Gr. 1 M14 - 11 × 9 DIN 376	Gr. 2 M18 - 14 × 11 DIN 376
	Gr. 2 M20 - 16 × 12 DIN 376
	Gr. 2 M22 - 18 × 14,5 DIN 376



Einsätze ohne Rutschkupplung

Tapping collets without clutch
Douilles sans limiteur de couple

Abmessung Size / Dimension	Abmessung Size / Dimension
Gr. 1 3,5 × 2,7	Gr. 2 6 × 4,9
Gr. 1 4,5 × 3,4	Gr. 2 8 × 6,2
Gr. 1 6 × 4,9	Gr. 2 9 × 7
Gr. 1 8 × 6,2	Gr. 2 10 × 8
Gr. 1 9 × 7	Gr. 2 11 × 9
Gr. 1 10 × 8	Gr. 2 12 × 9
Gr. 1 11 × 9	Gr. 2 14 × 11
	Gr. 2 16 × 12
	Gr. 2 18 × 14,5



**Gewindeschneid-Schnellwechselfutter
Zylinderschaft DIN 1835 B+E
mit Längenausgleich auf Druck und Zug
im Holzkasten inkl. Einsätze mit Rutschkupplung**
*Quick-change tapping chucks straight shank DIN 1835 B+E with
length compensation in a wooden box incl. tapping collets with clutch*
Mandrin de taraudage pour queues cylindriques straight shank DIN 1835
B+E avec compensation longitudinale dans coffret en bois incl. douilles
avec limiteur de couple

Bestell Nr. Order no. / Réf.	Abmessung Size / Dimension	Größe Size/ Taille	Stück Pcs.
120.16.2012.SR	20 - M3 / M14	Gr. 1	7
120.16.2020.SR	20 - M5 / M22	Gr. 2	9



**Gewindeschneid-Schnellwechselfutter
Zylinderschaft DIN 1835 B+E mit Längenausgleich
auf Druck und Zug im Holzkasten
inkl. Einsätze ohne Rutschkupplung**
*Quick-change tapping chucks straight shank DIN 1835 B+E with length com-
pensation in a wooden box incl. tapping collets without clutch*
Mandrin de taraudage pour queues cylindriques straight shank
DIN 1835 B+E avec compensation longitudinale dans coffret en bois incl.
douilles sans limiteur de couple

Bestell Nr. Order no. / Réf.	Abmessung Size / Dimension	Größe Size/ Taille	Stück Pcs.
120.16.2012.S	20 - M3 / M14	Gr. 1	7
120.16.2020.S	20 - M5 / M22	Gr. 2	9



Einsätze mit Rutschkupplung

Tapping collets with clutch
Douilles avec limiteur de couple

Abmessung Size / Dimension	Abmessung Size / Dimension
Gr. 1 M3 - 3,5 × 2,7 DIN 371	Gr. 2 M5 - 6 × 4,9 DIN 371
Gr. 1 M4 - 4,5 × 3,4 DIN 371	Gr. 2 M6 - 6 × 4,9 DIN 371
Gr. 1 M5 - 6 × 4,9 DIN 371	Gr. 2 M8 - 8 × 6,2 DIN 371
Gr. 1 M6 - 6 × 4,9 DIN 371	Gr. 2 M10 - 10 × 8 DIN 371
Gr. 1 M8 - 8 × 6,2 DIN 371	Gr. 2 M12 - 9 × 7 DIN 376
Gr. 1 M10 - 10 × 8 DIN 371	Gr. 2 M14 - 11 × 9 DIN 376
Gr. 1 M12 - 9 × 7 DIN 376	Gr. 2 M16 - 12 × 9 DIN 376
Gr. 1 M14 - 11 × 9 DIN 376	Gr. 2 M18 - 14 × 11 DIN 376
	Gr. 2 M20 - 16 × 12 DIN 376
	Gr. 2 M22 - 18 × 14,5 DIN 376



Einsätze ohne Rutschkupplung

Tapping collets without clutch
Douilles sans limiteur de couple

Abmessung Size / Dimension	Abmessung Size / Dimension
Gr. 1 3,5 × 2,7	Gr. 2 6 × 4,9
Gr. 1 4,5 × 3,4	Gr. 2 8 × 6,2
Gr. 1 6 × 4,9	Gr. 2 9 × 7
Gr. 1 8 × 6,2	Gr. 2 10 × 8
Gr. 1 9 × 7	Gr. 2 11 × 9
Gr. 1 10 × 8	Gr. 2 12 × 9
Gr. 1 11 × 9	Gr. 2 14 × 11
	Gr. 2 16 × 12
	Gr. 2 18 × 14,5



Gewindebohrer-Spannhülsen für Fräseraufnahmen DIN 1835 B

mit Schnellwechsel-Kupplung

Clamping sleeves for taps in end mill holders DIN 1835 B with quick change adaptor
Douilles de serrage à changement rapide pour tarauds dans des porte-fraises DIN 1835 B



Verwendung:
Für Maschinen mit steigungssynchronem Vorschub. Zur verdrehsicheren Spannung von Gewindebohrern in Fräseraufnahmen nach DIN 1835 B

Application:
For machines with rigid tapping. For safe clamping of taps in end mill holders according to DIN 1835 B

Application:
Pour machines avec broche synchronisée. Pour le serrage stable de tarauds dans des attachements porte-fraises suivant DIN 1835 B

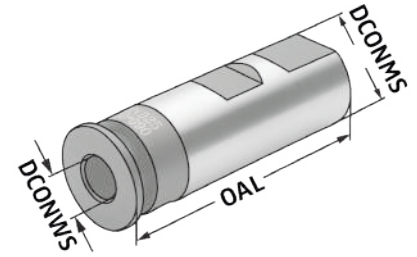

Bestell-Nr. Order no. Référence	DCONMS	DCONWS	DRVS Vierkant Square Carré	OAL
16.16.3527	16	3,5	2,7	56,0
16.16.4030	16	4,0	3,0	56,0
16.16.4534	16	4,5	3,4	56,0
16.16.649	16	6,0	4,9	56,0
16.20.4534	20	4,5	3,4	58,0
16.20.649	20	6,0	4,9	58,0
16.20.755	20	7,0	5,5	58,0
16.20.862	20	8,0	6,2	58,0
16.20.97	20	9,0	7,0	58,0
16.20.108	20	10,0	8,0	58,0
16.25.4534	25	4,5	3,4	66,0
16.25.649	25	6,0	4,9	66,0
16.25.755	25	7,0	5,5	66,0
16.25.862	25	8,0	6,2	66,0
16.25.97	25	9,0	7,0	66,0
16.25.108	25	10,0	8,0	66,0
16.25.119	25	11,0	9,0	66,0
16.25.129	25	12,0	9,0	66,0
16.32.649	32	6,0	4,9	70,0
16.32.755	32	7,0	5,5	70,0
16.32.862	32	8,0	6,2	70,0
16.32.97	32	9,0	7,0	70,0
16.32.108	32	10,0	8,0	70,0
16.32.119	32	11,0	9,0	70,0
16.32.129	32	12,0	9,0	70,0
16.32.1411	32	14,0	11,0	70,0
16.32.1612	32	16,0	12,0	70,0
16.32.18145	32	18,0	14,5	70,0

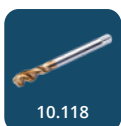

Clamping sleeves for taps in end mill holders DIN 1835 B

Douilles de serrage pour tarauds dans des porte-fraises DIN 1835 B



Verwendung:

Für Maschinen mit steigungssynchronem Vorschub. Zur verdrehsicheren Spannung von Gewindebohrern in Fräseraufnahmen nach DIN 1835 B.

Application:

For machines with rigid tapping. For safe clamping of taps in end mill holders according to DIN 1835 B.

Application:

Pour machines avec broche synchronisée. Pour le serrage stable de tarauds dans des porte-fraises suivant DIN 1835 B.

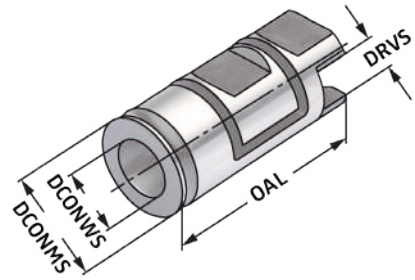

Bestell-Nr. Order no. Référence	DCONMS	DCONWS	DRVS Vierkant Square Carré	OAL
704.04.0825	8	2,5	2,1	36
704.04.0828	8	2,8	2,1	36
704.04.1035	10	3,5	2,7	40
704.04.1040	10	4,0	3,0	40
704.04.1045	10	4,5	3,4	40
704.04.1260	12	6,0	4,9	45
704.04.1470	14	7,0	5,5	45
704.04.1480	14	8,0	6,2	48
704.04.1690	16	9,0	7,0	48
704.04.1610	16	10,0	8,0	48
704.04.1811	18	11,0	9,0	50
704.04.2012	20	12,0	9,0	50
704.04.2514	25	14,0	11,0	56
704.04.2516	25	16,0	12,0	56
704.04.3216	32	16,0	14,5	60
704.04.3218	32	18,0	14,5	60
704.04.3220	32	20,0	16,0	60
704.04.3222	32	22,0	18,0	60
704.04.4025	40	25,0	20,0	70
704.04.4028	40	28,0	22,0	70
704.04.5022	50	22,0	18,0	81
704.04.5028	50	28,0	22,0	81
704.04.5032	50	32,0	24,0	81
704.04.5036	50	36,0	29,0	81
704.04.5040	50	40,0	32,0	81

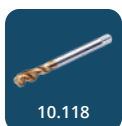

10.118

K Fräseranzugschrauben DIN 6367

Retaining screws DIN 6367
Vis de serrage DIN 6367



Verwendung:
Fräseranzugsschraube zum Befestigen von Aufsteckfräsern.

Application:
Retaining screw for mounting of face mills arbors.

Application:
Vis de serrage pour la fixation de fraises.

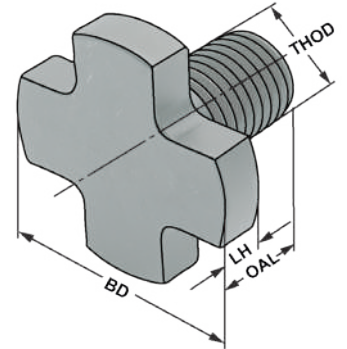

Bestell-Nr. Order no. Référence	Abmessung Size Dimension	THOD	BD	LH	OAL	TQX
102.10.16	16	M8	20	6	22	35
102.10.22	22	M10	28	7	25	75
102.10.27	27	M12	35	8	30	130
102.10.32	32	M16	42	9	35	320
102.10.40	40	M20	52	10	40	620
102.10.50	50	M24	63	12	48	1000
102.10.60	60	M30	75	14	60	2000

Fräseranzugschrauben DIN 6367 durchbohrt für Kühlmittelzufuhr

Retaining screws DIN 6367 with drill through for coolant
Vis de serrage DIN 6367 percée pour l'arrosage



Verwendung:
Fräseranzugsschraube zum Befestigen von Aufsteckfräsern.

Application:
Retaining screw for mounting of face mills arbors.

Application:
Vis de serrage pour la fixation de fraises.

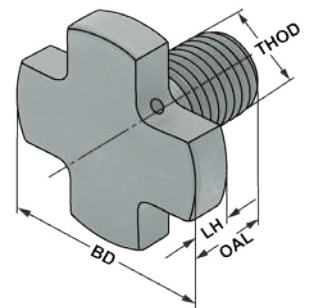

Bestell-Nr. Order no. Référence	Abmessung Size Dimension	THOD	BD	LH	OAL	TQX
102.11.16	16	M8	20	6	22	35
102.11.22	22	M10	28	7	25	75
102.11.27	27	M12	35	8	30	130
102.11.32	32	M16	42	9	35	320
102.11.40	40	M20	52	10	40	620
102.11.50	50	M24	63	12	48	1000
102.11.60	60	M30	75	14	60	2000



10

Zylinderschrauben für Quernut-Aufsteckdorne DIN 912



Hexagon Socket Head Cap Screws DIN 912
Vis tête cylindrique DIN 912



Verwendung:
Fräseranzugsschraube zum Befestigen von Aufsteckfräsern.
Application:
Retaining screw for mounting of face mills arbors.
Application:
Vis de serrage pour la fixation de fraises.

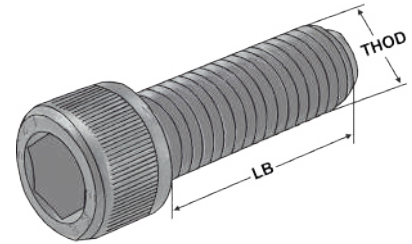

Bestell-Nr. Order no. Référence	Abmessung Size Dimension	THOD	LB	TQX
102.10.161	16	M8	25	35
102.10.221	22	M10	25	70
102.10.271	27	M12	35	120
102.10.321	32	M16	35	300
102.10.401	40	M20	40	500

Zylinderschrauben mit Kühlmittelnuten ~DIN 912

Hexagon Socket Head Cap Screws with coolant flutes ~DIN 912
Vis tête cylindrique avec rainures d'arrosage ~DIN 912



Verwendung:
Fräseranzugsschraube zum Befestigen von Aufsteckfräsern.
Application:
Retaining screw for mounting of face mills arbors.
Application:
Vis de serrage pour la fixation de fraises.

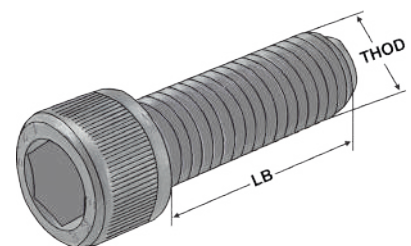

10

Bestell-Nr. Order no. Référence	Abmessung Size Dimension	THOD	LB	TQX
102.12.16	16	M8	30	35
102.12.22	22	M10	35	70
102.12.27	27	M12	35	120
102.12.32	32	M16	50	300



Nutenstein für Quernutdorn

Driving key for shell mill holder
Tasseaux pour porte-fraise à trou lisse



Verwendung:
Mitnehmersteine für Aufsteckfräser-
dorne PSK.

Application:
Drive Keys for shell end mill arbors.

Application:
Tenons d'entraînement pour mandrins
porte-fraise.

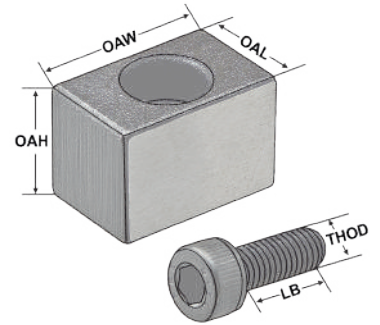

Bestell-Nr. Order no. Référence	Abmessung Size Dimension	OAL	OAW	OAH	THOD	LB	TQX
101.11.16	16	8	10,0	8	M3	12	4,4
101.11.22	22	10	11,0	11	M4	12	4,4
101.11.27	27	12	14,2	12,6	M4	16	4,4
101.11.32	32	14	22,0	14	M5	14	8,7
101.11.40	40	16	22,5	16	M5	14	36
101.11.60	60	25,4	32,7	25,4	M12	25	120

Spannschlüssel DIN 6368 für Aufsteckdorne

Wrenches DIN 6368 for shell arbors
Clés de serrage DIN 6368 pour broches creuses

Verwendung:
Für Fräseranzugsschraube DIN 6367.

Application:
For retaining screw DIN 6367.

Application:
Pour vis de fixation DIN 6367.

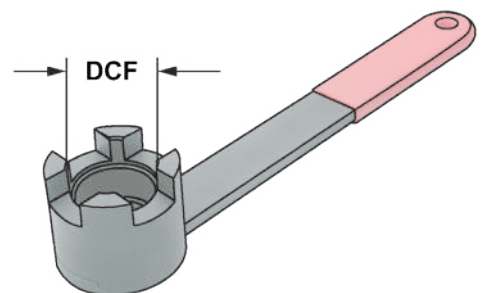
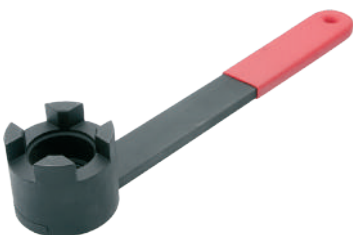

10

Bestell-Nr. Order no. Référence	DCF
10.16	16 M8
10.22	22 M10
10.27	27 M12
10.32	32 M16
10.40	40 M20
10.50	50 M24
10.60	60 M30

Feather keys
Ressort de passage



Verwendung:
Für Kombi-Aufsteckfräserdorne DIN 6358.
Application:
For combi shell mill holders DIN 6358.
Application:
Pour porte-fraises à double usage DIN 6358.

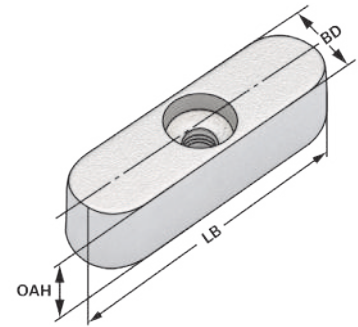

Bestell-Nr. Order no. Référence	OAH	BD	LB
101.10.16K	4	6	20
101.10.22K	6	6	25
101.10.27K	7	7	25
101.10.32K	7	8	28
101.10.40K	8	10	32

Mitnehmerringe DIN 6366

Clutch drive rings DIN 6366
Bagues d'entraînement DIN 6366



Verwendung:
Für Kombi-Aufsteckfräserdorne DIN 6358.
Application:
For combi shell mill holders DIN 6358.
Application:
Pour porte-fraises à double usage DIN 6358.

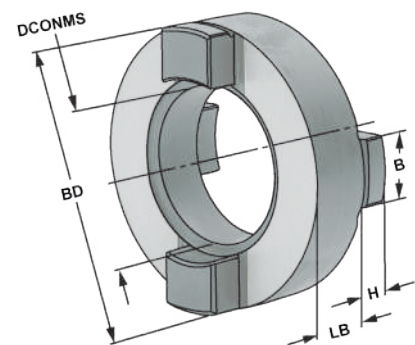

Bestell-Nr. Order no. Référence	DCONMS	BD	LB	B	H
101.10.16	16	32	10	8	5
101.10.22	22	40	12	10	5,6
101.10.27	27	46	12	12	6,3
101.10.32	32	55	14	14	7
101.10.40	40	68	14	16	8



Spannschrauben für Weldon Spannfutter DIN 1835 B

Clamping screws for Weldon chucks DIN 1835 B
Vis de serrage pour mandrins Weldon DIN 1835 B



Verwendung:
Für Fräseraufnahmen DIN 6359 für Zylinderschäfte DIN 1835-B
Application:
End mill holders DIN 6359 for Weldon type end mills DIN 1835-B
Application:
Porte-fraises DIN 6359 pour queues cylindriques Weldon DIN 1835-B

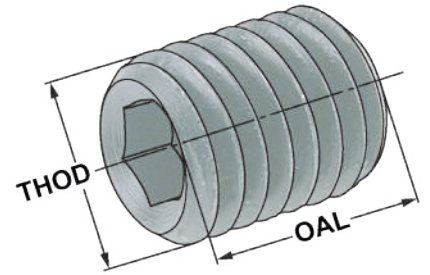

Bestell-Nr. Order no. Référence	THOD	OAL	für Durchmesser for diameter pour diamètre
101.04.06	M6 x 1	10	6
101.04.08	M8 x 1,25	10	8
101.04.10	M10 x 1,5	12	10
101.04.12	M12 x 1,75	16	12+14
101.04.16	M14 x 2	16	16+18
101.04.20	M16 x 2	16	20
101.04.25	M18 x 2	20	25
101.04.32	M20 x 2	20	32
101.04.40	M20 x 2	20	40

Spannschrauben für Weldon Spannfutter DIN 1835 B kurze Ausführung

Clamping screws for Weldon chucks DIN 1835 B short version
Vis de serrage pour mandrins Weldon DIN 1835 B version courte

10



Verwendung:
Für Fräseraufnahmen DIN 6359 für Zylinderschäfte DIN 1835-B
Application:
End mill holders DIN 6359 for Weldon type end mills DIN 1835-B
Application:
Porte-fraises DIN 6359 pour queues cylindriques Weldon DIN 1835-B

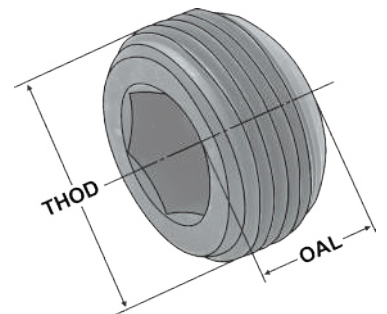

Bestell-Nr. Order no. Référence	THOD	OAL	für Artikelnummer for article number pour référence
101.04.16	M14	16	403.04.16.0 406.04.16.0
101.04.201	M16x1	8	403.04.20.0 + 403.04.25.0 + 403.04.32.0 406.04.20.0 + 406.04.25.0 + 406.04.32.0
101.04.202	M16x1	10	403.04.20.0 + 403.04.25.0 + 403.04.25.0 406.04.20.0 + 406.04.25.0
101.04.203	M16x1	12	403.04.32.0 + 406.04.32.0

Verstellschrauben für Weldon Whistle Notch DIN 1835 E



Adjusting Screws for Weldon chucks whistle notch DIN 1835 E
 Vis de réglage pour mandrins Weldon whistle notch DIN 1835 E



Verwendung:
 Zur Längeneinstellung des Schneidwerkzeugs
Application:
 For length adjustment of cutting tools
Application:
 Pour le réglage de la longueur de l'outil de coupe

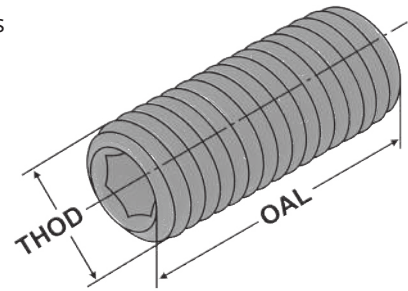

Bestell-Nr. Order no. Référence	THOD	OAL	für Durchmesser for diameter pour diamètre
102.05.06	M5x0,8	30	6
102.05.08	M6x1,0	30	8
102.05.10	M8x1,25	30	10
102.05.12	M10x1,5	30	12+14
102.05.16	M12x1,75	30	16+18
102.05.20	M16x2,0	30	20
102.05.25	M20x2,5	25	25+32+40

Verstellschrauben für Spannzangenfutter

Adjusting Screws for collet chucks
 Vis de réglage pour mandrin de serrage



Verwendung:
 Zur Längeneinstellung des Schneidwerkzeugs
Application:
 For length adjustment of cutting tools
Application:
 Pour le réglage de la longueur de l'outil de coupe

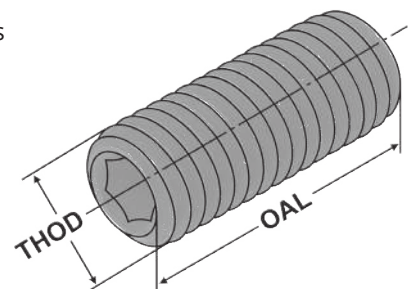

10

Bestell-Nr. Order no. Référence	THOD	OAL
101.02.03	M8 x 1,25 (ER11 Mini)	13
101.02.05	M10 x 1,5 (ER16)	20
101.02.10	M12 x 1,75 (ER20)	20
101.02.15	M16 x 2,0 (ER25 + ER32 + ER40)	20
101.02.716	7/16 x 20UN (ER16 Mini)	13
101.02.916	9/16 x 18UN (ER20 Mini)	13
101.02.1116	11/16 x 16UN (ER25 Mini)	13

K Spanschrauben für E1 Bohrerhalter

Clamping screws for E1 boring holders
Vis de serrage pour portes forets E1



Verwendung:
Für VDI-Bohrerhalter E1
Application:
For VDI boring holders E1
Application:
Pour portes forets VDI E1

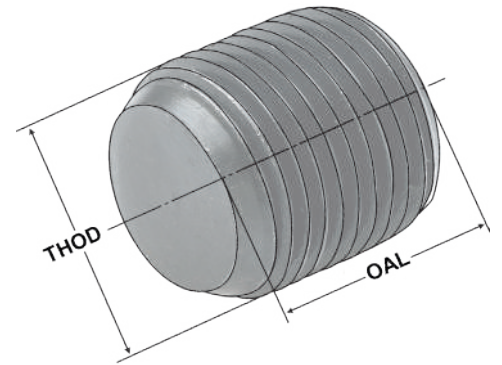

Bestell-Nr. Order no. Référence	THOD	OAL	für Artikelnummer for article number pour référence
102.91.10	M10x1	10	309.51.16 309.51.20 403.51.20 503.51.20
			409.51.16 409.51.20 A63.51.20
			509.51.16 509.51.20
102.91.12	M12x1	12	309.51.25 309.51.32 403.51.25 503.51.25
			409.51.25 409.51.32 403.51.32 503.51.32
			509.51.25 509.51.32 A63.51.25 A63.51.32
102.91.16	M16x1	12	309.51.40 503.51.40
			409.51.40 A63.51.40
			509.51.40 509.51.50

Spanschrauben für E1 Bohrerhalter mit Spitze

Clamping screws for E1 boring holders with point
Vis de serrage pour portes forets E1 avec pointe

10



Verwendung:
Für VDI-Bohrerhalter E1
Application:
For VDI boring holders E1
Application:
Pour portes forets VDI E1

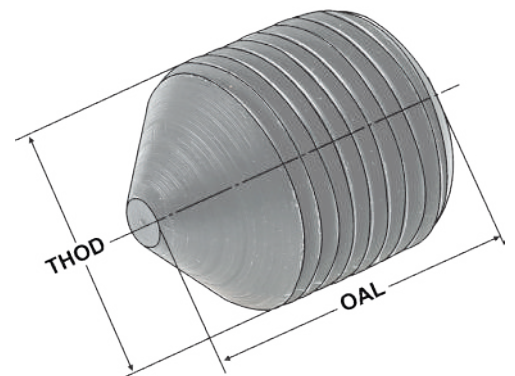

Bestell-Nr. Order no. Référence	THOD	OAL	für Artikelnummer for article number pour référence
102.93.10	M10x1	14	309.51.16 309.51.20 403.51.20 503.51.20
			409.51.16 409.51.20 A63.51.20
			509.51.16 509.51.20
102.93.12	M12x1	14	309.51.25 309.51.32 403.51.25 503.51.25
			409.51.25 409.51.32 403.51.32 503.51.32
			509.51.25 509.51.32 A63.51.25 A63.51.32
102.93.16	M16x1	14	309.51.40 503.51.40
			409.51.40 A63.51.40
			509.51.40 509.51.50

Clamping screws for E2 boring bar holders

Vis de serrage pour porte-outils pour barres d'alésage forme E2



Verwendung:
Für VDI-Bohrerhalter E2
Application:
For VDI boring holders E2
Application:
Pour portes forets VDI E2

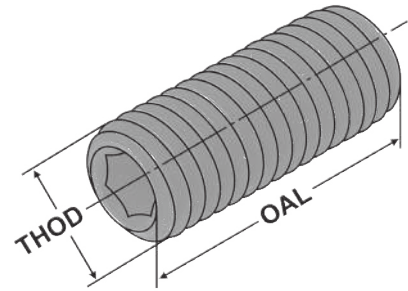

Bestell-Nr. Order no. Référence	THOD	OAL	für Artikelnummer for article number pour référence
102.91.06	M6	20	309.52.08 309.52.10
101.91.08.1	M8	16	309.52.16 309.52.20 309.52.25 309.52.32
101.91.08.2	M8	20	309.52.12 409.52.08 409.52.10 409.52.12
101.91.10	M10	12	409.52.40
101.91.10.1	M10	16	409.52.16 409.52.20 409.52.25 409.52.32
101.91.10.2	M10	20	509.52.12 509.52.16
101.91.12	M12	10	509.52.50
101.91.12.1	M12	16	509.52.32 509.52.40
101.91.12.2	M12	20	509.52.20 509.52.25



Hohlschlüssel mit Nasen / Nutmutternschlüssel

zur Demontage von Zwischenhülsen für MK mit Anzugsgewinde DIN 6364

Pipe key / groove-nut key for disassembling Morse taper adaptor for MT with drawbar thread DIN 6364
Clé pour écrou cylindrique à encoches pour le démontage de douilles cône morse
pour Douille de réduction pour CM avec filetage DIN 6364



Verwendung:
zur Demontage von Zwischenhülsen
Application:
for disassembling adaptor sleeves
Application:
pour le démontage de douilles cône morse

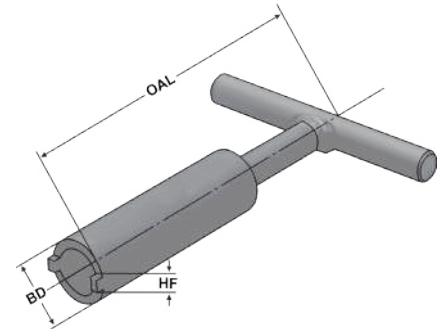

Bestell-Nr. Order no. Référence	BD	OAL	H	für Artikelnummer for article number pour référence
02.08.01	12,5	105	3	401.08.01 402.08.01 405.08.01
02.08.011	9,5	110	2	A63.08.01 A100.08.01
02.08.02	12,5	120	2,5	401.08.02 402.08.02 405.08.02 A63.08.02 A100.08.02
02.08.03	18,5	135	3	401.08.03 402.08.03 405.08.03 501.08.01 501.08.02 501.08.03 501.08.04 501.08.04A 502.08.01 502.08.02 502.08.03 502.08.04 502.08.04A 505.08.01 505.08.02 505.08.03 505.08.04 505.08.04A A63.08.03 A100.08.03
02.08.04	22,5	175	3	401.08.04 401.08.04A 402.08.04 402.08.04A 405.08.04 405.08.04A A63.08.04 A100.08.04
02.08.05	26,5	205	3	501.08.05 501.08.05A 502.08.05 502.08.05A 505.08.05 505.08.05A A100.08.05

Spare part set for Morse taper adaptor for MT with drawbar thread DIN 6364

Jeu de pièces détachées pour Douille de réduction pour CM avec filetage DIN 6364



Lieferumfang:
Schraube, Gewinding und Klemmschraube

Delivery:
Bolt, Holding ring, Screw on holding ring

Livraison:
Vis, bague fileté, vis de serrage

Bestell-Nr. Order no. Référence	Schraube Bolt vis	Gewinding Holding ring bague fileté	Klemmschraube clamping screw vis de serrage	für for pour
ERS.401.08.01	M6x40	M16 x 6,5 x 10	M5x6	SK 40-1-50 DIN 2080
ERS.401.08.02	M10x45	M16 x 6,5 x 10	M5x6	SK 40-2-50 DIN 2080
ERS.401.08.03	M12x35	M20 x 13 x 10	M5x6	SK 40-3-65 DIN 2080
ERS.401.08.04	M16x45	M26 x 16,5 x 13	M5x6	SK 40-4-95 DIN 2080
ERS.402.08.01	M6x25	M16 x 6,5 x 10	M5x6	SK 40-1-50 DIN 69871 AD
ERS.402.08.02	M10x25	M16 x 11 x 6	M5x6	SK 40-2-50 DIN 69871 AD
ERS.402.08.03	M12x35	M20 x 13 x 10	M5x6	SK 40-3-70 DIN 69871 AD
ERS.402.08.04	M16x45	M26 x 16,5 x 13	M5x6	SK 40-4-95 DIN 69871 AD
ERS.405.08.01	M6x25	M16 x 6,5 x 10	M5x6	BT 40-1-50 MAS-BT
ERS.405.08.02	M10x25	M16 x 6,5 x 10	M5x6	BT 40-2-50 MAS-BT
ERS.405.08.03	M12x35	M20 x 13 x 10	M5x6	BT 40-3-70 MAS-BT
ERS.405.08.04	M16x45	M26 x 16,5 x 13	M5x6	BT 40-4-95 MAS-BT
ERS.501.08.01	M6x55	M24 x 6,5 x 12	M6x10	SK 50-1-60 DIN 2080
ERS.501.08.02	M10x70	M24 x 11 x 12	M6x10	SK 50-2-60 DIN 2080
ERS.501.08.03	M12x35	M24 x 13 x 12	M5x6	SK 50-3-65 DIN 2080
ERS.501.08.04	M16x35	M24 x 15 x 9,5	M6x10	SK 50-4-65 DIN 2080
ERS.501.08.05	M20x50	M36 x 21 x 14	M6x10	SK 50-5-120 DIN 2080
ERS.502.08.01	M6x40	M24 x 6,5 x 12	M6x10	SK 50-1-60 DIN 69871 A
ERS.502.08.02	M10x45	M24 x 11 x 12	M6x10	SK 50-2-60 DIN 69871 A
ERS.502.08.03	M12x35	M24 x 13 x 12	M5x6	SK 50-3-65 DIN 69871 A
ERS.502.08.04	M16x35	M24 x 15 x 9,5	M6x10	SK 50-4-70 DIN 69871 A
ERS.502.08.05	M20x50	M36 x 21 x 14	M6x10	SK 50-5-100 DIN 69871 A
ERS.505.08.01	M6x40	M24 x 6,5 x 12	M6x10	BT 50-1-45 MAS-BT
ERS.505.08.02	M10x45	M24 x 11 x 12	M6x10	BT 50-2-60 MAS-BT
ERS.505.08.03	M12x35	M24 x 13 x 12	M5x6	BT 50-3-65 MAS-BT
ERS.505.08.04	M16x35	M24 x 15 x 9,5	M6x10	BT 50-4-70 MAS-BT
ERS.505.08.05	M20x50	M36 x 21 x 14	M6x10	BT 50-5-100 MAS-BT
ERS.A100.08.01	M6x25	M10 x 6,2 x 8	M5x6	HSK 100-1-110
ERS.A100.08.02	M10x25	M16 x 11 x 6	M5x6	HSK 100-2-120
ERS.A100.08.03	M12x25	M20 x 13 x 10	M5x6	HSK 100-3-150
ERS.A100.08.04	M16x25	M26 x 16,5 x 13	M5x6	HSK 100-4-170
ERS.A100.08.05	M20x51	M36 x 21 x 14	M6x10	HSK 100-5-200
ERS.A63.08.01	M6x25	M10 x 6,2 x 8	M5x6	HSK 63-1-100
ERS.A63.08.02	M10x28	M16 x 11 x 6	M5x6	HSK 63-2-120
ERS.A63.08.03	M12x35	M20 x 13 x 10	M5x6	HSK 63-3-140
ERS.A63.08.04	M16x45	M26 x 16,5 x 13	M5x6	HSK 63-4-160



Hohlschlüssel mit Nasen / Nutmutternschlüssel

zur Demontage von Zwischenhülsen für SK-Aufnahmen

Pipe key / groove-nut key for disassembling adaptor sleeves for ISO-toolholders

Clé pour écrou cylindrique à encoches pour le démontage de douilles cône morse



Verwendung:
zur Demontage von Zwischenhülsen
Application:
for disassembling adaptor sleeves
Application:
pour le démontage de douilles cône morse

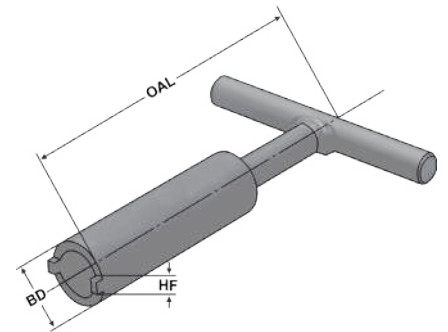

Bestell-Nr. Order no. Référence	BD	OAL	HF	für Artikelnummer for article number pour référence
02.09.30.1	18,5	111	4	401.09.30 402.09.30 405.09.30
02.09.40.1	24	141	2,8	401.09.40 402.09.40 405.09.40
02.09.40.2	20	111	2	501.09.40 502.09.40 505.09.40
02.09.50.2	35	166	3,5	501.09.50 502.09.50 505.09.50

Spare part set for Adaptor sleeves for ISO-toolholders

Jeu de pièces détachées pour Douilles de réduction pour porte-outils ISO/SA



Lieferumfang:
Schraube, Gewinding und Klemmschraube

Delivery:
Bolt, Holding ring, Screw on holding ring

Livraison:
Vis, bague filetée, vis de serrage

Bestell-Nr. Order no. Référence	Schraube Bolt vis	Gewinding Holding ring bague filetée	Klemmschraube clamping screw vis de serrage	für for pour
ERS.402.09.30	M12x50	M18 x 12,5 x 10	M5x6	SK40-SK30-50 DIN69871
ERS.402.09.40	M16x70	M26 x 16,5 x 13	M5x6	SK40-SK40-100 DIN69871
ERS.405.09.30	M12x50	M18 x 12,5 x 10	M5x6	SK40-SK30-50 MAS/BT
ERS.405.09.40	M16x70	M26 x 16,5 x 13	M5x6	SK40-SK40-100 DIN69871
ERS.502.09.40	M16x70	M24 x 15 x 9,5	M6x10	SK50-SK40-70 DIN69871
ERS.502.09.50	M24x80	M39 x 24,5 x 15	M6x10	SK50-SK50-120 DIN69871
ERS.505.09.40	M16x70	M24 x 15 x 9,5	M6x10	SK50-SK40-70 MAS/BT
ERS.505.09.50	M24x80	M39 x 24,5 x 15	M6x10	SK50-SK50-120 MAS/BT

K Montageblock universal mit Kugellager

Universal ball bearing tightening fixture
Bloc de montage universel avec palier à billes



Verwendung:

Für einfaches und sicheres Klemmen von Werkzeugaufnahmen am Bund mittels Rollen zum Montieren und Demontieren von Schneidwerkzeugen. Reibschlüssig, daher selbstklemmend und ideal für HSK Formen E und F sowie Polygonschaft Aufnahmen.

Application:

For easy and reliable clamping of tool arbors at the collar using rollers to mount and remove cutting tools – friction lock is self-clamping and ideal for HSK forms E and F, and also polygon shank arbors.

Application:

Pour le serrage simple et sûr de porte-outils au niveau de la collerette à l'aide de galets pour le montage et le démontage d'outils de coupe – entraînement par friction, autoserrant.

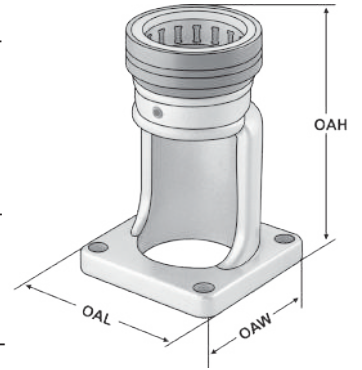

Bestell-Nr. Order no. Référence	Abmessung Size Dimension	OAL	OAW	OAH
707.1.032	HSK A32 - C32 - E32 - F32 - C3	110	110	165
707.1.040	HSK A40 - C40 - E40 - F40 - C4	110	110	165
707.1.050	HSK A50 - C50 - E50 - F50 - SK30 - C5	110	110	165
707.1.063	HSK A63 - C63 - E63 - F63 - BT40 - C6	110	110	172
707.1.080	HSK A80 - C80 - E80 - F80 - C8	160	160	215
707.1.100	HSK A100 - BT50	160	160	219
707.1.BT30	BT30	110	110	165
707.1.SK40	SK40	110	110	172
707.1.SK50	SK50	160	160	219

Universal assembly blocks made of steel, pivoted
 Blocs de montage universels en acier, pivotant



Verwendung:
 Schwenkbare Montagevorrichtung für
 Werkzeugaufnahmen. 360° drehbarer
 Kopf, arretierbar in verschiedenen Posi-
 tionen.

Application:
 Hinged mounting device for toolholders.
 Head turnable for 360°, lockable in diffe-
 rent positions.

Application:
 Appareil d'assemblage pivotant pour
 porte-outils. Tête tournant à 360°,
 arrêtable en différent positions.

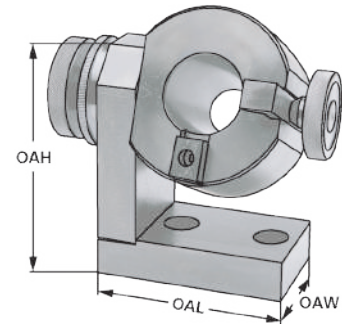

Bestell-Nr. Order no. Référence	Abmessung Size Dimension	OAL	OAW	OAH
705.30	SK/ISO/BT/CAT 30	111	65	134
705.40	SK/ISO/BT/CAT 40	111	65	132
705.50	SK/ISO/BT/CAT 50	111	65	175
708.32	HSK-A 32	111	65	132
708.40	HSK-A 40	111	65	132
708.50	HSK-A 50	111	65	132
708.63	HSK-A 63	111	65	132
708.80	HSK-A 80	111	65	132
708.10	HSK-A 100	111	65	132
709.16	VDI 16	100	48	97
709.20	VDI 20	100	48	97
709.30	VDI 30	111	65	132
709.40	VDI 40	111	65	132
709.50	VDI 50	111	65	132



K Montageblöcke aus Aluminium

Tightening fixtures made of aluminium
Blocs de montage en aluminium



Verwendung:
Montagevorrichtung zur vertikalen und horizontalen Aufnahme von Werkzeugen mit Steilkegelschaft.

Application:
Assembly device for vertical and horizontal mounting of tools with steep taper shank.

Application:
Dispositif de montage pour le montage vertical et horizontal de porte-outils conique.

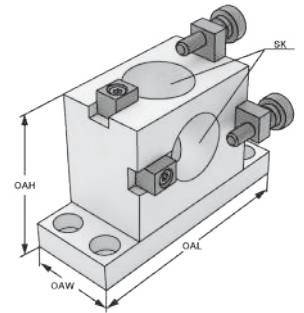

Bestell-Nr. Order no. Référence	Abmessung Size Dimension	OAL	OAW	OAH
700.30	SK/ISO/BT/CAT 30	126	47	75
700.40	SK/ISO/BT/CAT 40	160	60	100
700.50	SK/ISO/BT/CAT 50	180	97	155

Taper wipers
Nettoies cônes



Verwendung:

Zum Reinigen der Innenkegel an Maschinen-
spindeln, Hülsen und Werkzeugaufnahmen.

Application:

*For cleaning internal tapers on machine spindles,
sleeves and tool arbors.*

Application:

Destiné au nettoyage du cône de broches,
de douilles et de porte-outils.



Bestell-Nr. Order no. Référence	Abmessung Size Dimension	
710.01.415	OZ 16	
710.01.462	OZ 25	
710.01.467	OZ 32	
710.02.426	ER 16	
710.02.428	ER 20	
710.02.430	ER 25	
710.02.470	ER 32	
710.02.472	ER 40	
710.01	MK 1	
710.02	MK 2	
710.03	MK 3	
710.04	MK 4	
710.05	MK 5	
710.30	SK/ISO/BT/CAT 30	
710.40	SK/ISO/BT/CAT 40	
710.50	SK/ISO/BT/CAT 50	
710.32.HSK	HSK 32	Form A-C-E
710.40.HSK	HSK 40	Form A-C-E
710.50.HSK	HSK 50	Form A-C-E
710.63.HSK	HSK 63	Form A-C-E
710.80.HSK	HSK 80	Form A-C-E
710.100.HSK	HSK 100	Form A-C-E
710.63.HSK.F	HSK 63	Form F

Ausführung: Mit Rauhlederbesatz
Version: *With parts of leather*
Version: Parties en cuir

K Reinigungspropeller | Späne Booster

Cleaning propeller | Chip Blower
Hélice de nettoyage

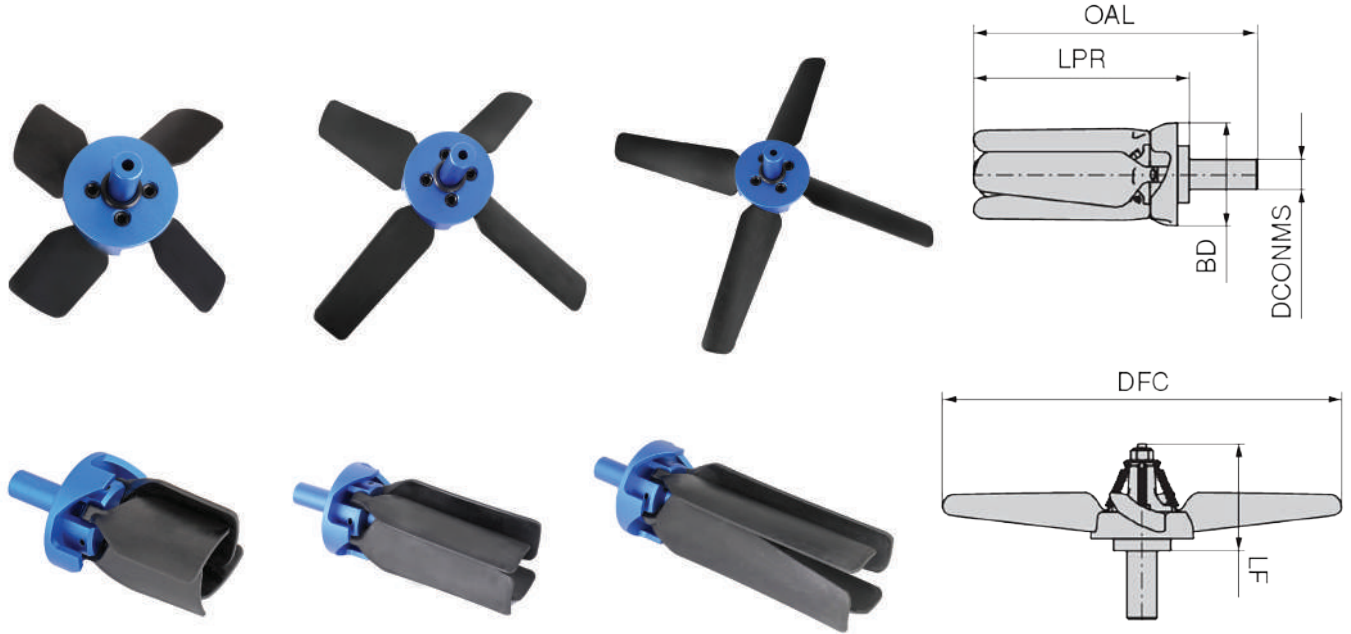

Bestell-Nr. Order no. Référence	OAL	LF	DCONMS	BD	LPR	DFC	RPMX	Vorschub Feed rate Alimentation
900.90.160	120	53	16	65	80	160	7000 - 12000 1/min.	1000~3000 mm/min
900.90.260	170	53	16	65	130	260	5000 - 8000 1/min.	3000~15000mm/min
900.90.330	205	53	16	65	165	330	4000 - 7000 1/min.	3000~15000mm/min

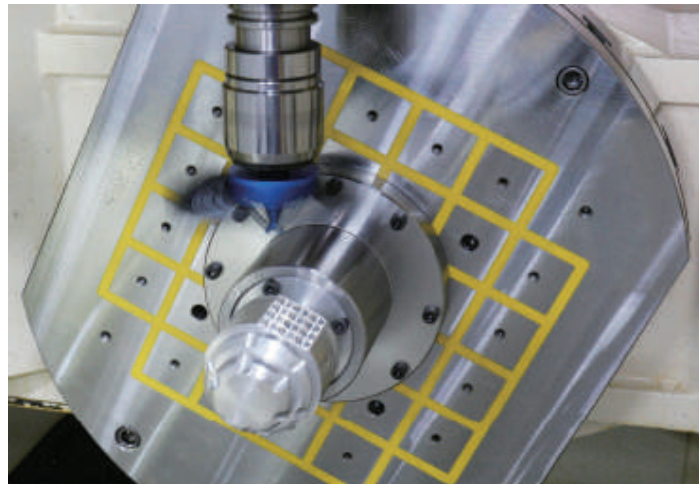

Ersatz-Reinigungs-Propeller Spare cleaning propeller Hélice de nettoyage de rechange

Bestell-Nr. Order no. Référence	Typ
ERS.900.90.160	160
ERS.900.90.260	170
ERS.900.90.330	330

Lieferumfang: 1 Stk. Rotorblatt; Inklusive Feder und Halte-Pin
Delivery: 1 pcs. rotor blade; Supplied with spring and retainer pin
Livraison: 1 pièce pale du rotor; Avec ressort et de maintien

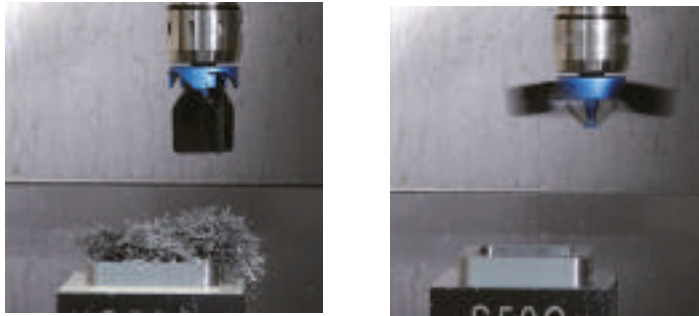

- Sichere und schnelle Methode um Späne und Kühlmittel zu entfernen
- Kühlung durch das Zentrum
- Robust und langlebig
- Verwendung mit Spannzangenfutter und Spannzangen 16mm
- Automatisches Einwechseln aus dem Werkzeugmagazin
- Öffnen und Schließen der Flügel erfolgt durch die Regelung der Spindelgeschwindigkeit
- Für vertikale und horizontale Bearbeitungszentren
- Mannloses Reinigen des Arbeitsraums der Werkzeugmaschinen
- Kostenersparnis durch Reduzierung der Nebenzeit

- *Safe and quick removal of chips and coolant*
- *Coolant goes through the center*
- *Robust and long-living*
- *Use with collet chucks and 16mm collets*
- *Usable with automatic tool changer*
- *Opening and closing of the flanks through the spindle speed control*
- *For vertical and horizontal processing centers*
- *Contact free cleaning of the working area of the machine*
- *Reduction of time expanses*

- Le système sûr et rapide pour évacuer les copeaux et le lubrifiant
- Avec arrosage centrale
- Solide et durable
- Pour mandrins à pince et pinces avec le diamètre 16 mm
- Changement automatique dans la machine industrielle
- Pour pouvoir effectuer l'ouverture et la fermeture des pales il faut changer la vitesse de la broche
- Pour les systèmes horizontales et verticales
- Le nettoyage sans contact
- Permettent économiser du temps

K Hydro-Dehnspannfutter mit Zylinderschaft

Hydraulic expansion chucks for tool shanks
Mandrins expansibles hydrauliques pour queues cylindriques



Verwendung:
Zur Aufnahme von Werkzeugen mit Zylinderschaft nach DIN 1835 Form A+B+E und DIN 6535 Form HA+HB+HE

Application:
For mounting straight-shank tools acc. DIN 1835 form A+B+E and DIN 6535 form HA+HB+HE

Application:
Pour le serrage d'outils avec queue cylindrique suivant DIN 1835 forme A+B+E et DIN 6535 forme HA+HB+HE

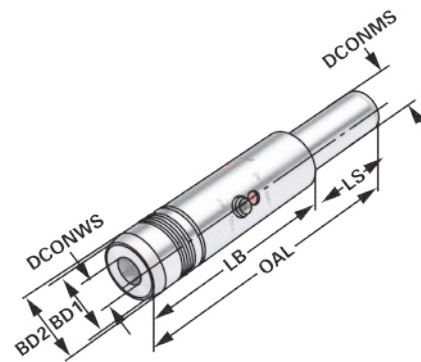

≤ 3µm

Bestell-Nr. Order no. Référence	DCONMS	DCONWS	BD1	BD2	OAL	LB	LS	DRVS
120.H12.12	12	12	21	25	146	100	46	4
120.H20.12	20	12	21	25	150	100	50	4
120.H20.16	20	16	25	28	150	100	50	4
120.H20.20	20	20	30	32	150	100	50	5
120.H32.12	32	12	21	25	200	140	60	4
120.H32.16	32	16	25	28	200	140	60	4
120.H32.20	32	20	30	32	200	140	60	5

Durchgangsbohrung für Innenkühlung vorhanden.
Through hole for internal cooling provided.
Trou débouchant disponible pour arrosage interne.

Lieferumfang: Ohne Spannschlüssel
Delivery: Without wrench
Livraison: Sans clé de serrage

10



Shrink fit extensions (with end stop)
Rallonges de frettage (avec butée)



Verwendung:
 Zur Aufnahme von Werkzeugen mit Zylinderschaft.
Application:
 For mounting straight-shank tools.
Application:
 Pour le serrage d'outils avec queue cylindrique.

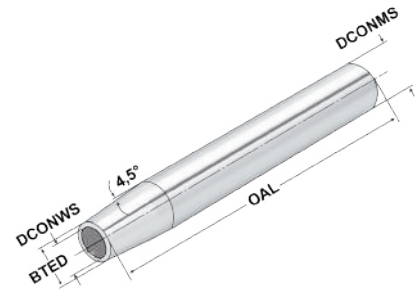

Bestell-Nr. Order no. Référence	DCONMS	DCONWS	BTED	OAL	LSCN	LSCX	ADJRGA	THID
120.70.03	20	3	10	150	6	-	-	-
120.70.04	20	4	10	150	8	-	-	-
120.70.05	20	5	10	150	10	-	-	-
120.70.06*	20	6	10	150	22	36	10	M5x0,8
120.70.08*	20	8	12	150	26	36	10	M6x1
120.70.10*	20	10	14	150	31	41	10	M8x1
120.70.12*	20	12	16	150	36	46	10	M10x1

* mit Anschlag | * with end stop | * avec butée

Durchgangsbohrung für Innenkühlung vorhanden.
Through hole for internal cooling provided.
 Trou débouchant disponible pour arrosage interne.

LSCX = Einspannlänge, max. ADJRGA = Verstellweg, max.
 LSCX = Clamping depth, max. ADJRGA = Length adjustment range, max.
 LSCX = Profondeur d'insertion, max. ADJRGA = Course de réglage, max.

Für Ø 3, 4 und 5 mm nur Hartmetallschäfte verwenden!
For Ø 3, 4 and 5 mm only solid carbide tool shanks must be used!
 Pour Ø 3, 4 et 5 mm il faut seulement utiliser de queues d'outils carbures de type HM!

Hinweis: Aufnahmen für Induktiv-, Kontakt- und Heißluftschumpfergeräte geeignet.
 Schafttoleranz bei Ø 3, 4 und 5 mm = h₄, bei Ø 6 – Ø 32 mm = h₆
Note: *Toolholders suitable for induction-, contact- and hot air shrink units.*
 Ø 3, 4, 5 with h₄-tolerance and Ø 6 – Ø 32 with h₆-tolerance
Observation: Porte-outils convenables pour machines à fretter par induction,
 par contact, ou par air chaud.
 Ø 3, 4, 5 avec h₄-tolerance et Ø 6 – Ø 32 avec h₆-tolerance

K Reduzierbuchsen für Bohrstanghalter Form E2

Reduction sleeves for boring bar holders form E2
 Douilles de réduction pour barres d'alésage forme E2



Form 1



Form 2

Verwendung:

Reduzierung zum Spannen von Werkzeugen mit Zylinderschaft, wie z. B. Feindreh-Bohrstangen.

Application:

Reduction for mounting tools with straight-shank, such as precision boring bars.

Application:

Réduction pour le serrage d'outils avec queue cylindrique, p. ex. barres d'alésage pour tournage de finition.

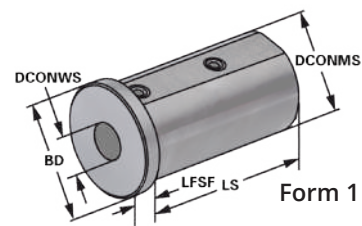

Form 1

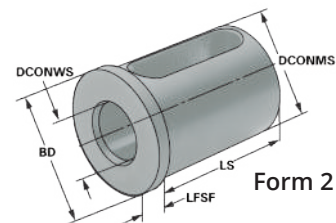

Form 2



Bestell-Nr. Order no. Référence	Form form forme	DCONMS	DCONWS	LS	LFSF	BD	OAL
709.25.06	1	25	6	46	5	29	51
709.25.08	1	25	8	46	5	29	51
709.25.10	1	25	10	46	5	29	51
709.25.12	1	25	12	46	5	29	51
709.25.14	1	25	14	46	5	29	51
709.25.16	2	25	16	46	5	29	51
709.25.18	2	25	18	46	5	29	51
709.25.20	2	25	20	46	5	29	51
709.32.06	1	32	6	55	5	36	60
709.32.08	1	32	8	55	5	36	60
709.32.10	1	32	10	55	5	36	60
709.32.12	1	32	12	55	5	36	60
709.32.14	1	32	14	55	5	36	60
709.32.16	2	32	16	55	5	36	60
709.32.18	2	32	18	55	5	36	60
709.32.20	2	32	20	55	5	36	60
709.32.25	2	32	25	55	5	36	60
709.40.06	1	40	6	71	5	44	76
709.40.08	1	40	8	71	5	44	76
709.40.10	1	40	10	71	5	44	76
709.40.12	1	40	12	71	5	44	76
709.40.14	1	40	14	71	5	44	76
709.40.16	2	40	16	71	5	44	76
709.40.18	2	40	18	71	5	44	76
709.40.20	2	40	20	71	5	44	76
709.40.25	2	40	25	71	5	44	76
709.40.32	2	40	32	71	5	44	76

Hinweis: Geeignet für Innenkühlung (nicht geschlitzt)
Note: Suitable for through-coolant (not slotted)
Observation: Convenable pour arrosage interne (non fendu)

Reduction sleeves set for boring bar holders form E2
 Douilles de réduction jeux pour barres d'alésage forme E2



Verwendung:
 Reduzierung zum Spannen von Werkzeugen mit Zylinderschaft, wie z. B. Feindreh-Bohrstangen.

Application:
 Reduction for mounting tools with straight-shank, such as precision boring bars.

Application:
 Réduction pour le serrage d'outils avec queue cylindrique, p. ex. barres d'alésage pour tournage de finition.

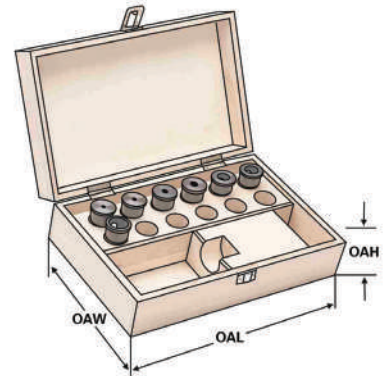

Bestell-Nr. Order no. Référence	Abmessung Size Dimension	OAL	OAW	OAH
701.709.25-S	Ø 25 Set 6 St. 06-08-10-12-16-20	360	235	70
701.709.32-S	Ø 32 Set 7 St. 06-08-10-12-16-20-25	360	235	70
701.709.40-S	Ø 40 Set 8 St. 06-08-10-12-16-20-25-32	360	235	70



Reduziereinsätze DIN 1835 B für Zylinderschäfte DIN 1835 B+E

Reducing bushes DIN 1835 B for tool shanks DIN 1835 B+E
Réductions DIN 1835 B pour queues cylindriques DIN 1835 B+E



Verwendung:
Zum Spannen von zylindrischen Werkzeugschäften nach DIN 1835 Form B+E.

Application:
For mounting straight-shank tools according to DIN 1835 form B+E.

Application:
Pour le serrage d'outils avec queue cylindrique suivant DIN 1835 forme B+E.

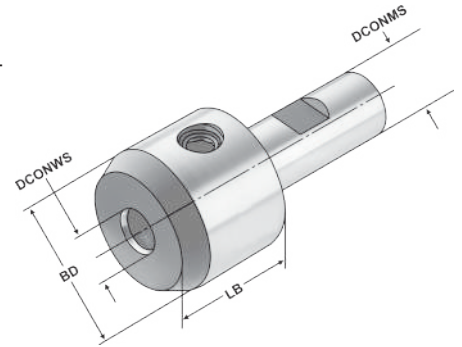

h6



H6

Bestell-Nr. Order no. Référence	DCONMS	DCONWS	BD	LB
122.20.06	20	6	25	30
122.20.08	20	8	28	30
122.20.10	20	10	35	30
122.20.12	20	12	42	35
122.32.06	32	6	25	30
122.32.08	32	8	28	30
122.32.10	32	10	35	30
122.32.12	32	12	42	35
122.32.14	32	14	44	35
122.32.16	32	16	48	38
122.32.18	32	18	50	38
122.32.20	32	20	52	40

Durchgangsbohrung für Innenkühlung vorhanden.
Through hole for internal cooling provided.
Trou débouchant disponible pour arrosage interne.

Lieferumfang: Mit Spannschraube
Delivery: With clamping screw
Livraison: Avec vis de serrage

Collet chucks with straight shank with Mini nuts ISO 15488 (DIN 6499) System ER

Mandrins à pinces à queue cylindrique avec mini-écrous ISO 15488 (DIN 6499) système ER



Verwendung:

Zur Aufnahme von Werkzeugen mit Zylinderschaft in Spannzangen.

Application:

For mounting straight-shank tools in collets.

Application:

Pour le serrage d'outils avec queue cylindrique dans des pinces de serrage.

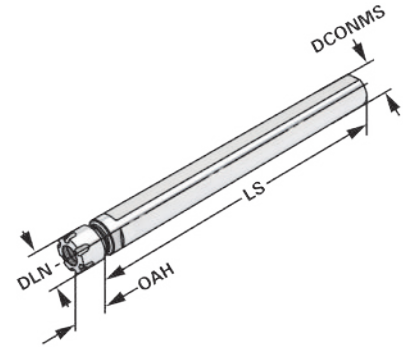

≤ 3µm



H6



Bestell-Nr. Order no. Référence	DCONMS	DCONWS Spannbereich Capacity Capacité	Typ	LS	OAH	DLN	DRVS	CND	THID
120.02.07	16	1 – 07	4008E ER 11	150	20	16	13	7	M8 x 1,25
120.02.10.1	20	1 – 10	426E ER 16	150	30	22	17	10	7/16" 20 UNF

Durchgangsbohrung für Innenkühlung vorhanden.

Through hole for internal cooling provided.

Trou débouchant disponible pour arrosage interne.

Lieferumfang: Inkl. Spannmutter

Delivery: Clamping nuts

Livraison: Ecrou de serrage



9.03



10.10



10.25

K Spannfutter mit Zylinderschaft für Spannzangen

ISO 15488 (DIN 6499) System ER

Collet chucks with straight shank for collets ISO 15488 (DIN 6499) ER-system
Mandrins à pinces à queue cylindrique pour pinces ISO 15488 (DIN 6499) système ER



Verwendung:
Zur Aufnahme von Werkzeugen mit Zylinderschaft in Spannzangen.

Application:
For mounting straight-shank tools in collets.

Application:
Pour le serrage d'outils avec queue cylindrique dans des pinces de serrage.

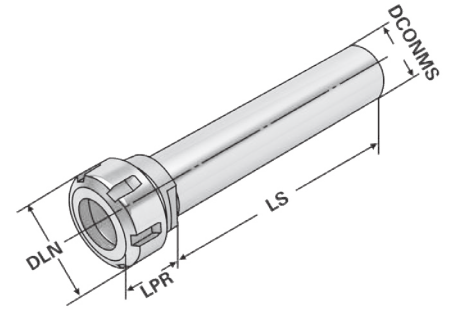

Bestell-Nr. Order no. Référence	DCONMS	DCONWS Spannbereich Capacity Capacité	Typ	LS	LPR	DLN	OAL	DRVS	CND	THID
120.02.10	16	1 - 10	426E ER 16	143	30	32	180	19	9	M10 x 1,5
120.02.16	20	1 - 16	430E ER 25	140	40	42	190	27	11	M12 x 1,5
120.02.20	32	2 - 20	470E ER 32	150	35	50	191	32	19	M20 x 1,5

Durchgangsbohrung für Innenkühlung vorhanden.
Through hole for internal cooling provided.
Trou débouchant disponible pour arrosage interne.

Lieferumfang: Inkl. Spannmutter
Delivery: Clamping nuts
Livraison: Ecrou de serrage

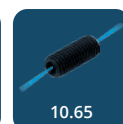

ISO 15488 (DIN 6499) System ER

Collet chucks with straight shank with with clamping surface for collets ISO 15488 (DIN 6499) ER-system
Mandrins à queue cylindrique avec surface de serrage pour pinces ISO 15488 (DIN 6499) système ER



Verwendung:
Zur Aufnahme von Werkzeugen mit Zylinderschaft in Spannzangen.

Application:
For mounting straight-shank tools in collets.

Application:
Pour le serrage d'outils avec queue cylindrique dans des pinces de serrage.

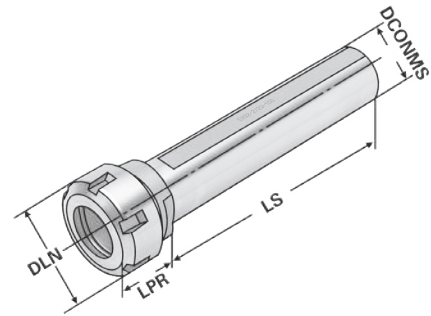

Bestell-Nr. Order no. Référence	DCONMS	DCONWS Spannbereich Capacity Capacité	Typ	LS	LPR	DLN	DRVS	CND	THID
120.02.04.10	16	1 – 10	426E ER 16	150	30	32	19	9	M10 x 1,5
120.02.04.16	20	1 – 16	430E ER 25	150	40	42	27	11	M12 x 1,5
120.02.04.20	32	2 – 20	470E ER 32	150	35	50	32	19	M20 x 1,5
120.02.04.20.1	40	2 – 20	470E ER 32	120	35	50	36	19	M20 x 1,5

Durchgangsbohrung für Innenkühlung vorhanden.
Through hole for internal cooling provided.
Trou débouchant disponible pour arrosage interne.

Lieferumfang: Inkl. Spannmutter
Delivery: Clamping nuts
Livraison: Ecrou de serrage

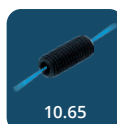
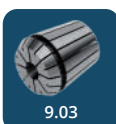

K Spannfutter mit Zylinderschaft für Spannzangen

ISO 15488 (DIN 6499) System ER

Collet chucks with straight shank for collets ISO 15488 (DIN 6499) ER-system
Mandrins à pinces à queue cylindrique pour pinces ISO 15488 (DIN 6499) système ER



Verwendung:
Zur Aufnahme von Werkzeugen mit Zylinderschaft in Spannzangen.

Application:
For mounting straight-shank tools in collets.

Application:
Pour le serrage d'outils avec queue cylindrique dans des pinces de serrage.

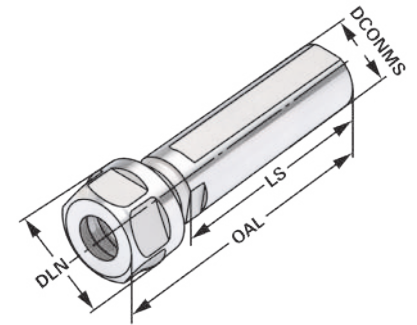

Bestell-Nr. Order no. Référence	DCONMS	DCONWS Spannbereich Capacity Capacité	Typ	DLN	LS	OAL	DRVS	CND	THID
120.02.A.07	20	1 - 07	4008E ER 11	19	50	67,5	17	7	-
120.02.A.07.1	20	1 - 07	4008E ER 11	19	70	87,5	17	7	-
120.02.A.10	20	1 - 10	426E ER 16	28	70	96,0	17	10	7/16" 20 UNF
120.02.A.13	25	1 - 13	428E ER 20	34	50	74,0	22	13	9/16" 18 UNF

Sechskantmutter
Hexagonal clamping nut
Écrous hexagonal

Durchgangsbohrung für Innenkühlung vorhanden.
Through hole for internal cooling provided.
Trou débouchant disponible pour arrosage interne.

Doppel-Spannzangenhalter mit Zylinderschaft für Spannzangen

ISO 15488 (DIN 6499) System ER

Double collet holder with straight shank for collets ISO 15488 (DIN 6499) ER-system
Porte-pinces doubles à queue cylindrique pour pinces ISO 15488 (DIN 6499) système ER

10



Verwendung:
Zur Aufnahme von Werkzeugen mit Zylinderschaft in Spannzangen.

Application:
For mounting straight-shank tools in collets.

Application:
Pour le serrage d'outils avec queue cylindrique dans des pinces de serrage.

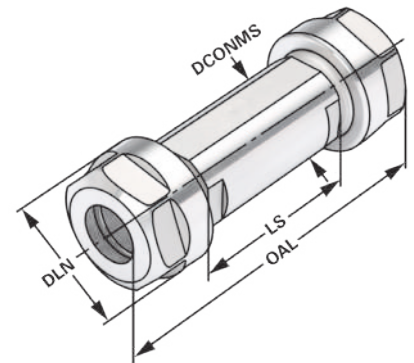

Bestell-Nr. Order no. Référence	DCONMS	DCONWS Spannbereich Capacity Capacité	Typ	DLN	LS	OAL	DRVS	CND	THID
120.02.B.13	25	1 - 13	428E ER 20	34	50	98,0	22	13	-

Sechskantmutter
Hexagonal clamping nut
Écrous hexagonal

Durchgangsbohrung für Innenkühlung vorhanden.
Through hole for internal cooling provided.
Trou débouchant disponible pour arrosage interne.

Collet chucks with straight shank with Mini nuts ISO 15488 (DIN 6499) System ER
Mandrins à pinces à queue cylindrique avec mini-écrous ISO 15488 (DIN 6499) système ER



Verwendung:
Zur Aufnahme von Werkzeugen mit Zylinderschaft in Spannzangen.

Application:
For mounting straight-shank tools in collets.

Application:
Pour le serrage d'outils avec queue cylindrique dans des pinces de serrage.

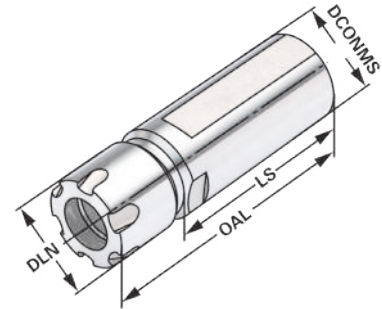

Bestell-Nr. Order no. Référence	DCONMS	DCONWS Spannbereich Capacity Capacité	Typ	DLN	LS	OAL	DRVS	CND	THID
120.02.C.10	22	1 – 10	426E ER 16	22	50	76,5	20	10	7/16" 20 UNF

Mit Minimutter
With mini nut
Avec écrous-mini

Durchgangsbohrung für Innenkühlung vorhanden.
Through hole for internal cooling provided.
Trou débouchant disponible pour arrosage interne.

Doppel-Spannzangenhalter mit Zylinderschaft mit Minimutter DIN 6499 (ISO 15488) System ER

Double collet holder with straight shank with Mini nuts ISO 15488 (DIN 6499) System ER
Porte-pinces doubles à queue cylindrique avec mini-écrous ISO 15488 (DIN 6499) système ER



Verwendung:
Zur Aufnahme von Werkzeugen mit Zylinderschaft in Spannzangen.

Application:
For mounting straight-shank tools in collets.

Application:
Pour le serrage d'outils avec queue cylindrique dans des pinces de serrage.

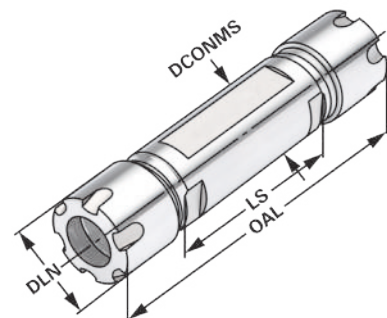

10



Bestell-Nr. Order no. Référence	DCONMS	DCONWS Spannbereich Capacity Capacité	Typ	DLN	LS	OAL	DRVS	CND	THID
120.02.D.10	20	1 – 10	426E ER 16	22	70	123	17	10	-

Mit Minimutter
With mini nut
Avec écrous-mini

Durchgangsbohrung für Innenkühlung vorhanden.
Through hole for internal cooling provided.
Trou débouchant disponible pour arrosage interne.

K Präzisions-Schnellspann-Bohrfutter für Bohrfutteraufnahmen DIN 238

Precision rapid clamping drill chucks for drill chuck adaptors DIN 238
Mandrins de perçage précis à serrage rapide pour arbres DIN 238



Verwendung:
Zur Aufnahme von Werkzeugen mit Zylinderschaft.
Application:
For mounting tools with straight shanks.
Application:
Pour le serrage d'outils avec queue cylindrique.

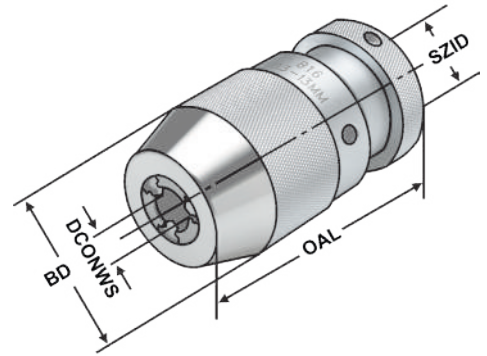

Bestell-Nr. Order no. Référence	SZID	DCONWS Spannbereich Capacity Capacité	BD	OAL
14.08.B12	B12	0,3 - 8	37	80
14.13.B16	B16	0,5 - 13	50	95,5
14.16.B16	B16	3,0 - 16	50	103,5

Hinweis: Schlüssellos, selbstspannend
Note: Keyless, self-clamping
Observation: Sans clé, serrage automatique



CNC-Drill chucks for drill chuck adaptors DIN 238
Mandrins de perçage CNC pour arbres DIN 238



Verwendung:
Zur Aufnahme von Werkzeugen mit Zylinderschaft.

Application:
For mounting tools with straight shanks.

Application:
Pour le serrage d'outils avec queue cylindrique.

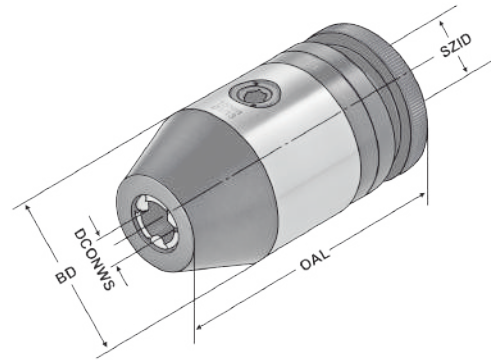

Bestell-Nr. Order no. Référence	SZID	DCONWS Spannbereich Capacity Capacité	BD	OAL	DRVS
15.08.B12	B12	0 - 8	37	84,2	4
15.13.B16	B16	1,0 - 13	50	106	6
15.16.B16	B16	2,5 - 16	50	114	6

- Hinweis:** Hohe Präzision und Rundlaufgenauigkeit von $\leq 0,03$ mm. Sichere Spannung des Werkzeuges durch mechanische Spannkraftverstärkung. Kein selbständiges Lösen der Spannung während der Bearbeitung bei Links- oder Rechtslauf, sowie bei Spindelstop. Spannen und Lösen mit Sechskantschlüssel.
- Note:** *High precision and accurate concentricity of ≤ 0.03 mm. Secure gripping of the tool through mechanical amplification of the clamping force. No automatic slackening of the clamping force while machining with either clockwise or counter clockwise rotation or on spindle stop. Clamping and releasing effected by means of an Allen wrench.*
- Observation:** Précision élevée et exactitude de circularité de $\leq 0,03$ mm. Serrage sûr de l'outil grâce à l'amplification de la force de serrage. Pas de desserrage intempestif en cours d'usinage lors de la rotation la gauche ou la droite, de même qu'en cas d'arrêt de la broche. Serrage et desserrage en utilisant un clé sur à fourche.
- Lieferumfang:** Ohne Spannschlüssel
Delivery: Without wrench
Livraison: Sans clé de serrage

Durchgangsbohrung für Innenkühlung vorhanden.
Through hole for internal cooling provided.
Trou débouchant disponible pour arrosage interne.



K CNC-Bohrfutter mit Zylinderschaft DIN 1835 B

CNC-Drill chucks with straight shank DIN 1835 B
Mandrins de perçage CNC à queue cylindrique DIN 1835 B



Verwendung:
Zur Aufnahme von Werkzeugen mit Zylinderschaft.

Application:
For mounting tools with straight shanks.

Application:
Pour le serrage d'outils avec queue cylindrique.

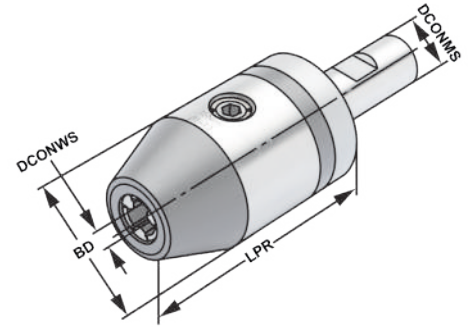

≤ 30µm



13.04

Bestell-Nr. Order no. Référence	DCONMS	DCONWS Spannbereich Capacity Capacité	LPR	BD	OAL	DRVS
120.15.2013	20	1,0 – 13	82,3	50	144	6
120.15.2016	20	2,5 – 16	87,5	50	149	6

Hinweis: Hohe Präzision und Rundlaufgenauigkeit von $\leq 0,03$ mm. Sichere Spannung des Werkzeuges durch mechanische Spannkraftverstärkung. Kein selbständiges Lösen der Spannung während der Bearbeitung bei Links- oder Rechtslauf, sowie bei Spindelstop. Spannen und Lösen mit Sechskantschlüssel.

Note: *High precision and accurate concentricity of ≤ 0.03 mm. Secure gripping of the tool through mechanical amplification of the clamping force. No automatic slackening of the clamping force while machining with either clockwise or counter clockwise rotation or on spindle stop. Clamping and releasing effected by means of an Allen wrench.*

Observation: Précision élevée et exactitude de circularité de $\leq 0,03$ mm. Serrage sûr de l'outil grâce à l'amplification de la force de serrage. Pas de desserrage intempestif en cours d'usinage lors de la rotation la gauche ou la droite, de même qu'en cas d'arrêt de la broche. Serrage et desserrage en utilisant un clé sur à fourche.

Lieferumfang: Ohne Spanschlüssel
Delivery: Without wrench
Livraison: Sans clé de serrage



CNC-Drill chucks for MT
Mandrins de perçage CNC pour CM



Verwendung:
Zur Aufnahme von Werkzeugen mit Zylinderschaft.

Application:
For mounting tools with straight shanks.

Application:
Pour le serrage d'outils avec queue cylindrique.

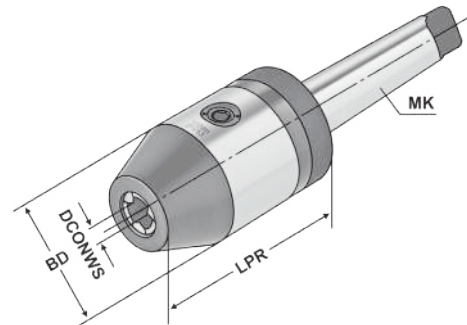

DIN 228
Form B
≤ 30µm

13.04

Bestell-Nr. Order no. Référence	MK MT CM	DCONWS Spannbereich Capacity Capacité	LPR	BD	DRVS
107.15.313	3	1,0 – 13	98	50	6
107.15.316	3	2,5 – 16	103	50	6
107.15.413	4	1,0 – 13	100	50	6
107.15.416	4	2,5 – 16	105	50	6

Hinweis: Hohe Präzision und Rundlaufgenauigkeit von $\leq 0,03$ mm. Sichere Spannung des Werkzeuges durch mechanische Spannkraftverstärkung. Kein selbständiges Lösen der Spannung während der Bearbeitung bei Links- oder Rechtslauf, sowie bei Spindelstop. Spannen und Lösen mit Sechskantschlüssel.

Note: *High precision and accurate concentricity of ≤ 0.03 mm. Secure gripping of the tool through mechanical amplification of the clamping force. No automatic slacking of the clamping force while machining with either clockwise or counter clockwise rotation or on spindle stop. Clamping and releasing effected by means of an Allen wrench.*

Observation: Précision élevée et exactitude de circularité de $\leq 0,03$ mm. Serrage sûr de l'outil grâce à l'amplification de la force de serrage. Pas de desserrage intempestif en cours d'usinage lors de la rotation la gauche ou la droite, de même qu'en cas d'arrêt de la broche. Serrage et desserrage en utilisant un clé sur à fourche.

Lieferumfang: Ohne Spanschlüssel
Delivery: Without wrench
Livraison: Sans clé de serrage

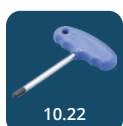

K Hartmetall Zentrierspitzen - DIN 806 HE

abgeflachte Ausführung mit Hartmetall-Einsatz 60°

Solid half point with carbide insert - DIN 806 HE 60°

Demi-pointe fixe avec insert en métal dur - DIN 806 HE 60°



Verwendung:

Zum Plandrehen der Stirnflächen und für kleine Durchmesser.

Application:

For front surfacing and small diameters.

Application:

Pour surfacer les faces et pour les petits diamètres.

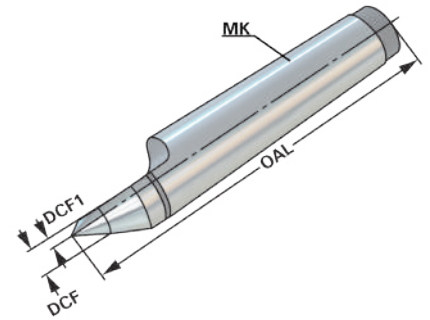

Bestell-Nr. Order no. Référence	MK	DCF1	DCF	OAL
109.11.01	1	1,5	5,5	80
109.11.02	2	2	6	100
109.11.03	3	3	9	125
109.11.04	4	5	12,5	160
109.11.05	5	7	16	200

Volle Ausführung mit Hartmetall-Einsatz 60°

Solid lathe centre with carbide insert - DIN 806 E 60°
 Pointe fixe avec insert en métal dur - DIN 806 E 60°



Verwendung:
 Zum Plandrehen der Stirflächen und für kleine Durchmesser.
Application:
 For front surfacing and small diameters.
Application:
 Pour surfacer les faces et pour les petits diamètres.

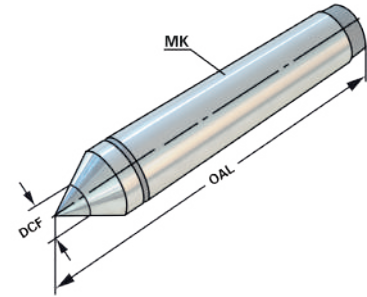

Bestell-Nr. Order no. Référence	MK	DCF	OAL
109.12.01	1	8	80
109.12.02	2	8	100
109.12.03	3	12	125
109.12.04	4	15	160
109.12.05	5	18	200

K Mitlaufende Drehbankspitze 60°

Revolving lathe centre 60°
Pointe tournante 60°

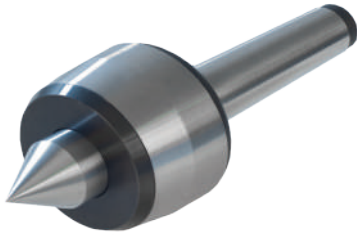

Verwendung:
Im Reitstock der Drehmaschinen, damit zwischen Werkstück und Spitze keine Reibung entsteht.

Application:
In the tailstock of the lathe so that no friction occurs between the workpiece and the tip.

Application:
Dans la contre-poupée de la Tourneuse afin qu'aucun frottement a lieu entre la pièce à usiner et la pointe.

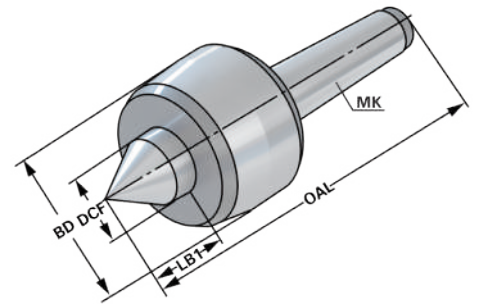

Bestell-Nr. Order no. Référence	MK	OAL	BD	LB1	DCF	Max. Drehzahl Speed Tours	Max. kg Werkstück Work piece Pièce à usiner
109.14.01	1	114	36	17	15	7000	100
109.14.02	2	129	45	24	20	7000	200
109.14.03	3	151,5	50	27,5	22	5000	500
109.14.04	4	205	70	41	32	3800	800
109.14.05	5	258,5	90	51	40	3000	2000

Mitlaufende Drehbankspitze mit verlängerter Spitze 60°



Revolving lathe centre with extended point 60°
Pointe tournante allongée 60°



Verwendung:
Im Reitstock der Drehmaschinen, damit zwischen Werkstück und Spitze keine Reibung entsteht.

Application:
In the tailstock of the lathe so that no friction occurs between the workpiece and the tip.

Application:
Dans la contre-poupée de la Tourneuse afin qu'aucun frottement a lieu entre la pièce à usiner et la pointe.

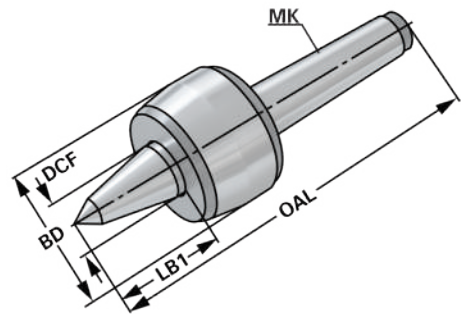

Bestell-Nr. Order no. Référence	MK	OAL	BD	LB1	DCF	Max. Drehzahl Speed Tours	Max. kg Werkstück Work piece Pièce à usiner
109.13.02	2	139	45	34	20	7000	140
109.13.03	3	176,5	60	47	25	5000	400
109.13.04	4	217	70	53	32	3800	500
109.13.05	5	273	90	65	40	3000	1200



Parallel-Unterlagen-Sätze

Set of parallel supports
Jeu de supports parallèles



Verwendung:

Parallelunterlagen finden vielseitige Verwendung als Hilfsmittel zum Spannen und Positionieren, z.B. beim Schleifen, Fräsen, Erodieren, Messen und Anreissen.

Application:

Parallels are widely used as a tool for tensioning and positioning, e.g. during grinding, milling, EDM, gauging and scribing.

Application:

Parallèles sont largement utilisés comme un outil pour la tension et le positionnement, p. e., pendant l'affûtage, fraisage, EDM, mesurage et traçage.

Bestell-Nr. Order no. Référence	Ausführung Version Type
91.12.150.1	14 x 2 - 150 x 10 x 14 (16,18,20,22,24,26,28,30,32,35,40,45,50)
91.12.150.2	14 x 2 - 150 x 8 x 14 (16,18,20,22,24,26,28,30,32,35,40,45,50)
91.12.200.3	14 x 2 - 200 x 10 x 14 (16,18,20,22,24,26,28,30,32,35,40,45,50)
91.13.100.1	9 x 2 - 100 x 4 x 10 (14,18,22,26,30,34,38,42)

Härte: HRC 55 - 62
Hardness: HRC 55 - 62
Dureté: HRC 55 - 62

Genauigkeit: 0,01mm
Accuracy: 0,01mm
Exactitude: 0,01mm

Parallelität: 0,005mm
Parallelism: 0,005mm
Parallélisme: 0,005mm

O-ring for end mill holder with coolant channels
 Joints torique pour porte-fraises avec canaux d'arrosage



Verwendung:
 Für Fräseraufnahmen mit Kühlkanälen
 DIN 6359 für Zylinderschäfte DIN 1835-B

Application:
 End mill holders with cooling channels
 DIN 6359 for Weldon type end mills DIN 1835-B

Application:
 Porte-fraises avec canaux d'arrosage
 DIN 6359 pour queues cylindriques Weldon
 DIN 1835-B

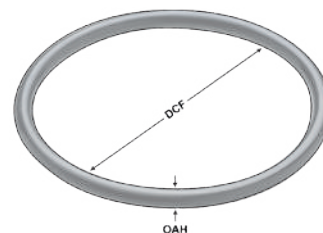

Bestell-Nr. Order no. Référence	DCF	OAH
101.04.06R	5,8	1,9
101.04.08R	7,8	1,8
101.04.10R	9,8	2,4
101.04.12R	11,8	2,4
101.04.14R	13,8	2,4
101.04.16R	15,8	2,4
101.04.18R	17,8	2,4
101.04.20R	19,8	2,4
101.04.25R	24,7	3,5
101.04.32R	31,7	3,5
101.04.40R	39,7	3,5

Trolley for CNC toolholders incl. tool carrier and inserts

Chariots pour porte-outils CNC incl. support pour porte-outils et inserts



Verwendung:
Lagerung und sicherer Transport von CNC-Werkzeugaufnahmen.

Application:
The optimal storage and save transport of CNC tools.

Application:
Stockage idéal et transport en sécurité pour outils.

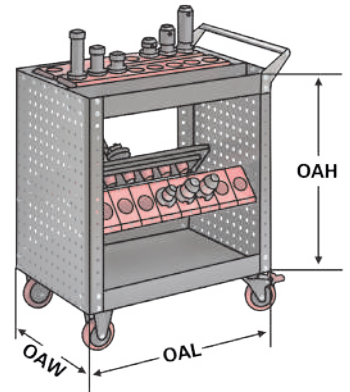

Bestell-Nr. Order no. Référence	Ausführung Version Type	Einsätze inserts inserts	OAL	OAW	OAH
784.01.30	SK 30	36	873	500	810
784.01.40	SK 40	32	873	500	810
784.01.50	SK 50	24	873	500	810
784.02.63	HSK 63	28	873	500	810

Werkzeugaufnahmeträger als Erweiterung für Werkzeugwagen (ohne Einsätze)

CNC-tool carrier as extension (without inserts)

Support pour porte-outils CNC en tant qu'extension (sans inserts)

10



Verwendung:
Lagerung von CNC-Werkzeugaufnahmen.

Application:
The optimal storage of CNC tools.

Application:
Stockage idéal et transport en sécurité pour outils.

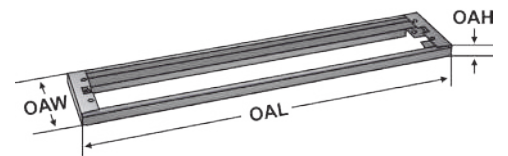

Bestell-Nr. Order no. Référence	Ausführung Version Type	OAL	OAW	OAH
Z.784.01	passend für suitable for adapté à 784.*	705	145	25

Stand for CNC toolholders incl. inserts
Étagère pour porte-outils CNC incl. inserts



Verwendung:
Lagerung von
CNC-Werkzeugaufnahmen.
Application:
The optimal storage of CNC tools.
Application:
Stockage idéal et transport en
sécurité pour outils.

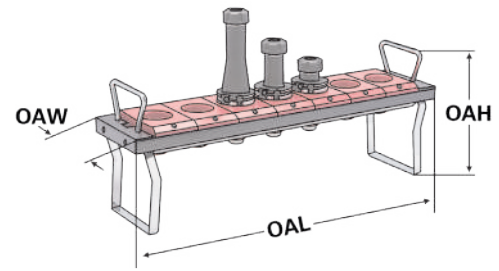

Bestell-Nr. Order no. Référence	Ausführung Version Type	Einsätze inserts inserts	OAL	OAW	OAH
781.01.30	SK 30	8	595	143	175
781.01.40	SK 40	7	595	143	175
781.01.50	SK 50	5	595	143	175
781.02.63	HSK 63	6	595	143	175

CNC-Werkzeugeinsätze

CNC-inserts
Inserts pour porte-outils CNC



Verwendung:
Lagerung von
CNC-Werkzeugaufnahmen.
Application:
The optimal storage of CNC tools.
Application:
Stockage idéal et transport en
sécurité pour outils.

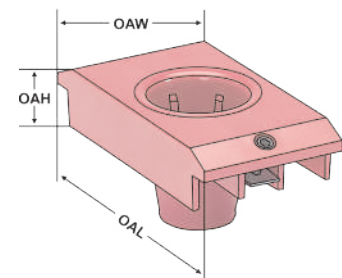

10

Bestell-Nr. Order no. Référence	Ausführung Version Type	OAL	OAW	OAH
782.01.30	SK 30	137	74	30
782.01.40	SK 40	137	74	30
782.01.50	SK 50	137	74	30
782.02.63	HSK 63	137	74	30



Bench stand for CNC toolholders - without inserts
Étagère pour porte-outils CNC - sans inserts

2 oder 4 Kassetten mit verschraubtem Korpus,
Ablage und Haltegriffen
(Inkl. Werkzeugaufnahmeträger, ohne Einsätze)

2 or 4 magazines with bolted corpus, rack and handles
(incl. Tool carrier, without inserts)

2 ou 4 cassettes avec corps vissé, support et poignées
(avec support, sans inserts)



Bestell-Nr.	Abmessung BxTxH	E1	E2	E3
Order no. / Référence	Size / Dimension	*	*	*
788.8705.200	425x375x300	14	10	6



Bestell-Nr.	Abmessung BxTxH	E1	E2	E3
Order no. / Référence	Size / Dimension	*	*	*
788.8707.200	575x375x300	20	14	10



Bestell-Nr.	Abmessung BxTxH	E1	E2	E3
Order no. / Référence	Size / Dimension	*	*	*
788.8705.400	425x375x525	28	20	12

10



Bestell-Nr.	Abmessung BxTxH	E1	E2	E3
Order no. / Référence	Size / Dimension	*	*	*
788.8707.400	575x375x525	40	28	20

*Anzahl der möglichen Einsätze, für die Größen E1, E2, E3

* Quantity of possible inserts, for sizes E1, E2, E3

* Nombre des inserts possibles, pour les tailles E1, E2, E3

Trolley for CNC toolholders - without Tool carrier and without inserts
 Chariot pour porte-outils CNC - sans support et sans inserts

CNC Werkzeugwagen (leer) für max. 8 CNC Träger
Maximale Tragkraft 400 kg
Ohne Werkzeugaufnahmeträger und ohne Einsätze

Trolley (empty) for max. 8 carriers
Maximum lifting force 400kg.
(Without Tool carrier and without inserts)
 Chariot (vide) pour 8 supports
 Maximum force portante max. 400 kg
 (sans support et sans inserts)



Bestell-Nr.	Abmessung BxTxH
Order no. / Référence	Size / Dimension
799.02.88.0	630x900x860

CNC Werkzeugaufnahmeträger

Tool carrier for CNC toolholders
 Support pour porte-outils CNC

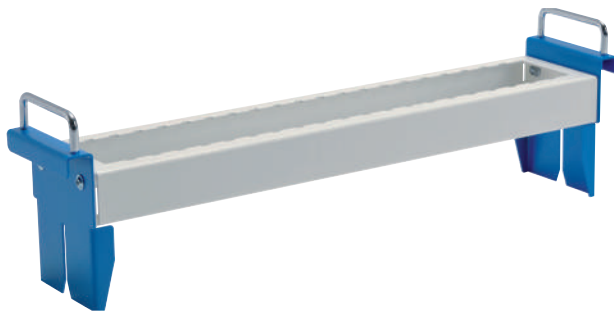

Bestell-Nr.	Abmessung BxTxH	E1	E2	E3
Order no. / Référence	Size / Dimension	*	*	*
799.28.707.100	620x120x180	10	7	5

*Anzahl der möglichen Einsätze, für die Größen E1, E2, E3

* Quantity of possible inserts, for sizes E1, E2, E3

* Nombre des inserts possibles, pour les tailles E1, E2, E3

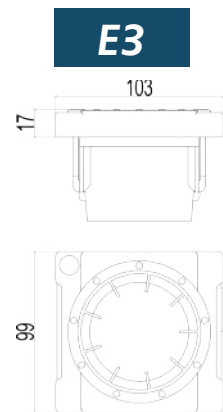
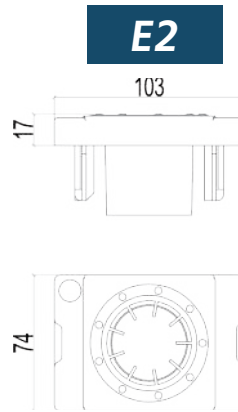
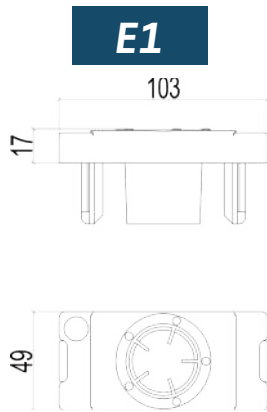

E1	
Bestell-Nr. Order no. / Référence	Abmessung Size / Dimension
785.01.30	ISO / SK 30
785.02.30	VDI 30
785.03.30	MK 3
785.03.40	MK 4



E2	
Bestell-Nr. Order no. / Référence	Abmessung Size / Dimension
785.01.40	SK 40
785.02.40	VDI 40
786.01.50	HSK A 50 / B63 / F63
786.01.63	HSK A 63 / B80
785.03.50	MK 5



E3	
Bestell-Nr. Order no. / Référence	Abmessung Size / Dimension
785.01.50	ISO / SK 50
785.02.50	VDI 50
786.01.80	HSK A 80 / B100
786.01.100	HSK A 100 / B125



E3	
Bestell-Nr. Order no. / Référence	Abmessung Size / Dimension
786.01.40	HSK A 40 / B 50



E3	
Bestell-Nr. Order no. / Référence	Abmessung Size / Dimension
786.01.32	HSK A 32 / B 40

Inserts for CNC toolholders
 Inserts pour porte-outils CNC

E3

Bestell-Nr. Order no. / Référence	Abmessung Size / Dimension
786.01.00	Universal



E3

Bestell-Nr. Order no. / Référence	Abmessung Size / Dimension
786.01.03	Capto C3



E1

Bestell-Nr. Order no. / Référence	Abmessung Size / Dimension
786.01.04	Capto C4



E2

Bestell-Nr. Order no. / Référence	Abmessung Size / Dimension
786.01.05	Capto C5



E3

Bestell-Nr. Order no. / Référence	Abmessung Size / Dimension
786.01.06	Capto C6



E3

Bestell-Nr. Order no. / Référence	Abmessung Size / Dimension
786.01.08	Capto C8

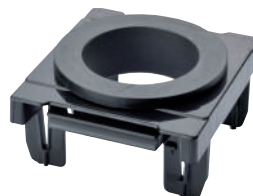

K Stahl Bohrstangen SCLC L 06 links

Steel boring bars SCLC L 06 left
Barres d'alésage en acier SCLC L 06 à gauche

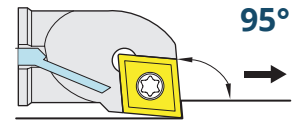

- Schwingungsarme Bohrstangen
- Mit Innenkühlung
- Längere Standzeit der Wendeschneidplatten
- Längsdrehen, sehr gut geeignet für enge Bohrungen
- Anstellwinkel: 95°
- Lieferumfang: Ohne Wendeschneidplatten
- **Low-vibration boring bars**
- **With internal cooling**
- **Longer durability of inserts**
- **For longitudinal and plane turning**
- **Setting angle: 95°**
- **Delivery: without inserts**
- Barres d'alésage à faibles vibrations
- Avec arrosage interne
- Longue durée de vie des plaquettes
- Tournage longitudinale, très bien adapté pour les trous serrés
- Angle d'incidence: 95°
- Livraison: sans plaquettes

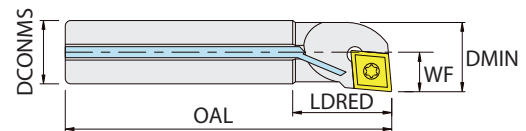

Bestell Nr. Order no. Référence	Wendeplatte Inserts Plaquettes	DCONMS	WF	OAL	LDRED	DMIN	TQX
A0608H.SCLC.L06	CCMT / CCGT 0602...	8	4	100	25	8	1,2 Nm
A0810J.SCLC.L06	CCMT / CCGT 0602...	10	5	110	32	10	1,2 Nm
A1012K.SCLC.L06	CCMT / CCGT 0602...	12	6	125	38	12	1,2 Nm
A1216M.SCLC.L06	CCMT / CCGT 0602...	16	8	150	50	16	1,2 Nm

10

Stahl Bohrstangen Satz SCLC L 06 links

Steel boring bars set SCLC L 06 left
Set de barres d'alésage en acier SCLC L 06 à gauche

Bestell Nr. Order no. Référence	Satz beinhaltet Set consist of Set composé
SET.A.SCLC.L06	A0608H.SCLC.L06 A0810J.SCLC.L06 A1012K.SCLC.L06 A1216M.SCLC.L06



101.TX8
Torx Klemmschrauben
Torx clamping screw
Torx



02.TX8
Torx-Schraubendreher TX8
Torx screwdriver TX8
Tournevis Torx TX8

Stahl Bohrstangen SCLC R 06 rechts



Steel boring bars SCLC R 06 right
Barres d'alésage en acier SCLC R 06 droite

- Schwingungsarme Bohrstangen
- Mit Innenkühlung
- Längere Standzeit der Wendeschneidplatten
- Längsdrehen, sehr gut geeignet für enge Bohrungen
- Anstellwinkel: 95°
- Lieferumfang: Ohne Wendeschneidplatten

- *Low-vibration boring bars*
- *With internal cooling*
- *Longer durability of inserts*
- *For longitudinal and plane turning*
- *Setting angle: 95°*
- *Delivery: without inserts*

- Barres d'alésage à faibles vibrations
- Avec arrosage interne
- Longue durée de vie des plaquettes
- Tournage longitudinale, très bien adapté pour les trous serrés
- Angle d'incidence: 95°
- Livraison: sans plaquettes

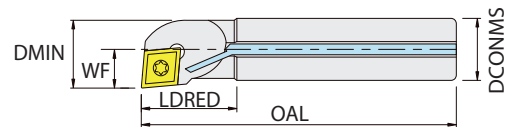
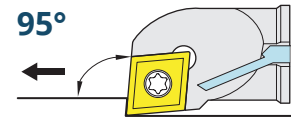

Bestell Nr. Order no. Référence	Wendepatte Inserts Plaquettes	DCONMS	WF	OAL	LDRED	DMIN
A0608H.SCLC.R06	CCMT / CCGT 0602...	8	4	100	25	8
A0810J.SCLC.R06	CCMT / CCGT 0602...	10	5	110	32	10
A1012K.SCLC.R06	CCMT / CCGT 0602...	12	6	125	38	12
A1216M.SCLC.R06	CCMT / CCGT 0602...	16	8	150	50	16

Stahl Bohrstangen Satz SCLC L 06 rechts

Steel boring bars set SCLC L 06 right
Set de barres d'alésage en acier SCLC L 06 droite

Bestell Nr. Order no. Référence	Satz beinhaltet Set consist of Set composé
SET.A.SCLC.R06	A0608H.SCLC.R06 A0810J.SCLC.R06 A1012K.SCLC.R06 A1216M.SCLC.R06



10



101.TX8
Torx Klemmschrauben
Torx clamping screw
Torx



02.TX8
Torx-Schraubendreher TX8
Torx screwdriver TX8
Tournevis Torx TX8

K Stahl Bohrstangen SDUC L 07 links

Steel boring bars SDUC L 07 left
Barres d'alsage en acier SDUC L 07 à gauche

- Schwingungsarme Bohrstangen
- Mit Innenkühlung
- Längere Standzeit der Wendeschneidplatten
- Längsdrehen, sehr gut geeignet für enge Bohrungen
- Anstellwinkel: 93°
- Lieferumfang: Ohne Wendeschneidplatten

- **Low-vibration boring bars**
- **With internal cooling**
- **Longer durability of inserts**
- **For longitudinal and plane turning**
- **Setting angle: 93° Delivery: without inserts**

- Barres d'alsage à faibles vibrations
- Avec arrosage interne
- Longue durée de vie des plaquettes
- Tournage longitudinale, très bien adapté pour les trous serrés
- Angle d'incidence: 93°
- Livraison: sans plaquettes

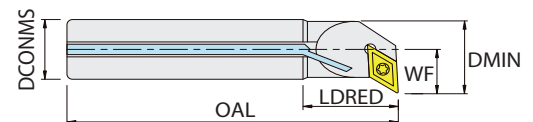
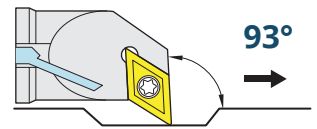

Bestell Nr. Order no. Référence	Wendeplatte Inserts Plaquettes	DCONMS	WF	OAL	LDRED	DMIN
A0810H.SDUC.L07	DCMT-DCGT 0702..	10	7	100	22	12,5
A1012K.SDUC.L07	DCMT-DCGT 0702..	12	9	125	28	15,5
A1216M.SDUC.L07	DCMT-DCGT 0702..	16	11	150	36	19,5

10

Stahl Bohrstangen Satz SDUC L 07 links

Steel boring bars set SDUC L 07 left
Set de barres d'alsage en acier SDUC L 07 à gauche

Bestell Nr. Order no. Référence	Satz beinhaltet Set consist of Set composé
SET.A.SDUC.L07	A0810H.SDUC.L07 A1012K.SDUC.L07 A1216M.SDUC.L07



101.TX8
Torx Klemmschrauben
Torx clamping screw
Torx



02.TX8
Torx-Schraubendreher TX8
Torx screwdriver TX8
Tournevis Torx TX8

Stahl Bohrstangen SDUC R 07 rechts



Steel boring bars SDUC R 07 right
Barres d'alésage en acier SDUC R 07 droite

- Schwingungsarme Bohrstangen
- Mit Innenkühlung
- Längere Standzeit der Wendeschneidplatten
- Längsdrehen, sehr gut geeignet für enge Bohrungen
- Anstellwinkel: 93°
- Lieferumfang: Ohne Wendeschneidplatten

- *Low-vibration boring bars*
- *With internal cooling*
- *Longer durability of inserts*
- *For longitudinal and plane turning*
- *Setting angle: 93° Delivery: without inserts*

- Barres d'alésage à faibles vibrations
- Avec arrosage interne
- Longue durée de vie des plaquettes
- Tournage longitudinale, très bien adapté pour les trous serrés
- Angle d'incidence: 93°
- Livraison: sans plaquettes

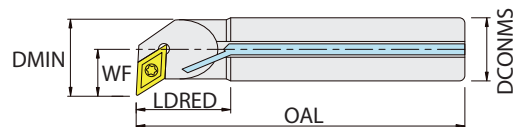
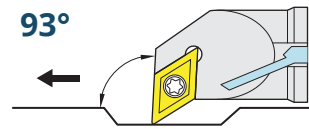

Bestell Nr. Order no. Référence	Wendeplatte Inserts Plaquettes	DCONMS	WF	OAL	LDRED	DMIN
A0810H.SDUC.R07	DCMT-DCGT 0702..	10	7	100	22	12,5
A1012K.SDUC.R07	DCMT-DCGT 0702..	12	9	125	28	15,5
A1216M.SDUC.R07	DCMT-DCGT 0702..	16	11	150	36	19,5

Stahl Bohrstangen Satz SDUC R 07 rechts

Steel boring bars set SDUC R 07 right
Set de barres d'alésage en acier SDUC R 07 droite

Bestell Nr. Order no. Référence	Satz beinhaltet Set consist of Set composé
SET.A.SDUC.R07	A0810H.SDUC.R07 A1012K.SDUC.R07 A1216M.SDUC.R07



10



101.TX8
Torx Klemmschrauben
Torx clamping screw
Torx



02.TX8
Torx-Schraubendreher TX8
Torx screwdriver TX8
Tournevis Torx TX8

K HSS Bohrstangen SCLC L 06 links

HSS boring bars SCLC L 06 left
Barres d'alésage HSS SCLC L 06 à gauche

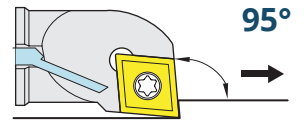

- Schwingungsarme Bohrstangen
- Mit Innenkühlung
- Längere Standzeit der Wendeschneidplatten
- Längsdrehen, sehr gut geeignet für enge Bohrungen
- Anstellwinkel: 95°
- Lieferumfang: Ohne Wendeschneidplatten
- *Low-vibration boring bars*
- *With internal cooling*
- *Longer durability of inserts*
- *For longitudinal and plane turning*
- *Setting angle: 95°*
- *Delivery: without inserts*
- Barres d'alésage à faibles vibrations
- Avec arrosage interne
- Longue durée de vie des plaquettes
- Tournage longitudinale, très bien adapté pour les trous serrés
- Angle d'incidence: 95°
- Livraison: sans plaquettes

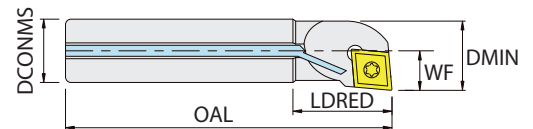

Bestell Nr. Order no. Référence	Wendepatte Inserts Plaquettes	DCONMS	WF	OAL	LDRED	DMIN
AH0608H.SCLC.L06	CCMT / CCGT 0602...	8	4	100	25	8
AH0810J.SCLC.L06	CCMT / CCGT 0602...	10	5	110	32	10
AH1012K.SCLC.L06	CCMT / CCGT 0602...	12	6	125	38	12
AH1216M.SCLC.L06	CCMT / CCGT 0602...	16	8	150	50	16

10

HSS Bohrstangen Satz SCLC L 06 links

HSS boring bars set SCLC L 06 left
Set de barres d'alésage HSS SCLC L 06 à gauche

Bestell Nr. Order no. Référence	Satz beinhaltet Set consist of Set composé
SET.AH.SCLC.L06	AH0608H.SCLC.L06 AH0810J.SCLC.L06 AH1012K.SCLC.L06 AH1216M.SCLC.L06



101.TX8
 Torx Klemmschrauben
 Torx clamping screw
 Torx



02.TX8
 Torx-Schraubendreher TX8
 Torx screwdriver TX8
 Tournevis Torx TX8

HSS Bohrstangen SCLC R 06 rechts



HSS boring bars SCLC R 06 right
Barres d'alésage HSS SCLC R 06 droite

- Schwingungsarme Bohrstangen
- Mit Innenkühlung
- Längere Standzeit der Wendeschneidplatten
- Längsdrehen, sehr gut geeignet für enge Bohrungen
- Anstellwinkel: 95°
- Lieferumfang: Ohne Wendeschneidplatten
- *Low-vibration boring bars*
- *With internal cooling*
- *Longer durability of inserts*
- *For longitudinal and plane turning*
- *Setting angle: 95°*
- *Delivery: without inserts*
- Barres d'alésage à faibles vibrations
- Avec arrosage interne
- Longue durée de vie des plaquettes
- Tournage longitudinale, très bien adapté pour les trous serrés
- Angle d'incidence: 95°
- Livraison: sans plaquettes

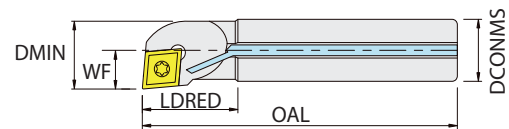
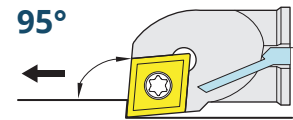

Bestell Nr. Order no. Référence	Wendeplatte Inserts Plaquettes	DCONMS	WF	OAL	LDRED	DMIN
AH0608H.SCLC.R06	CCMT / CCGT 0602...	8	4	100	25	8
AH0810J.SCLC.R06	CCMT / CCGT 0602...	10	5	110	32	10
AH1012K.SCLC.R06	CCMT / CCGT 0602...	12	6	125	38	12
AH1216M.SCLC.R06	CCMT / CCGT 0602...	16	8	150	50	16

HSS Bohrstangen Satz SCLC R 06 rechts

HSS boring bars set SCLC R 06 right
Set de barres d'alésage HSS SCLC R 06 droite

Bestell Nr. Order no. Référence	Satz beinhaltet Set consist of Set composé
SET.AH.SCLC.R06	AH0608H.SCLC.R06 AH0810J.SCLC.R06 AH1012K.SCLC.R06 AH1216M.SCLC.R06



10



101.TX8
Torx Klemmschrauben
Torx clamping screw
Torx



02.TX8
Torx-Schraubendreher TX8
Torx screwdriver TX8
Tournevis Torx TX8

K HSS Bohrstangen SDUC L 07 links

HSS boring bars SDUC L 07 left
Barres d'alésage HSS SDUC L 07 à gauche

- Schwingungsarme Bohrstangen
- Mit Innenkühlung
- Längere Standzeit der Wendeschneidplatten
- Längsdrehen, sehr gut geeignet für enge Bohrungen
- Anstellwinkel: 93°
- Lieferumfang: Ohne Wendeschneidplatten
- **Low-vibration boring bars**
- **With internal cooling**
- **Longer durability of inserts**
- **For longitudinal and plane turning**
- **Setting angle: 93°**
- **Delivery: without inserts**
- Barres d'alésage à faibles vibrations
- Avec arrosage interne
- Longue durée de vie des plaquettes
- Tournage longitudinale, très bien adapté pour les trous serrés
- Angle d'incidence: 93°
- Livraison: sans plaquettes

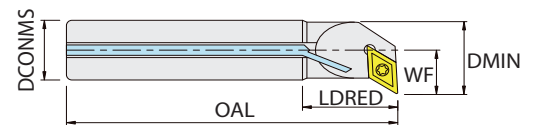
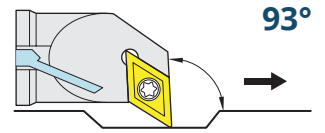

Bestell Nr. Order no. Référence	Wendepatte Inserts Plaquettes	DCONMS	WF	OAL	LDRED	DMIN
AH0810H.SDUC.L07	DCMT-DCGT 0702..	10	7	100	22	12,5
AH1012K.SDUC.L07	DCMT-DCGT 0702..	12	9	125	28	15,5
AH1216M.SDUC.L07	DCMT-DCGT 0702..	16	11	150	36	19,5

10

HSS Bohrstangen Satz SDUC L 07 links

HSS boring bars set SDUC L 07 left
Set de barres d'alésage HSS SDUC L 07 à gauche

Bestell Nr. Order no. Référence	Satz beinhaltet Set consist of Set composé
SET.AH.SDUC.L07	AH0810H.SDUC.L07 AH1012K.SDUC.L07 AH1216M.SDUC.L07



101.TX8
 Torx Klemmschrauben
 Torx clamping screw
 Torx



02.TX8
 Torx-Schraubendreher TX8
 Torx screwdriver TX8
 Tournevis Torx TX8

HSS Bohrstangen SDUC R 07 rechts



HSS boring bars SDUC R 07 right
Barres d'alésage HSS SDUC R 07 droite

- Schwingungsarme Bohrstangen
- Mit Innenkühlung
- Längere Standzeit der Wendeschneidplatten
- Längsdrehen, sehr gut geeignet für enge Bohrungen
- Anstellwinkel: 93°
- Lieferumfang: Ohne Wendeschneidplatten

- *Low-vibration boring bars*
- *With internal cooling*
- *Longer durability of inserts*
- *For longitudinal and plane turning*
- *Setting angle: 93°*
- *Delivery: without inserts*

- Barres d'alésage à faibles vibrations
- Avec arrosage interne
- Longue durée de vie des plaquettes
- Tournage longitudinale, très bien adapté pour les trous serrés
- Angle d'incidence: 93°
- Livraison: sans plaquettes

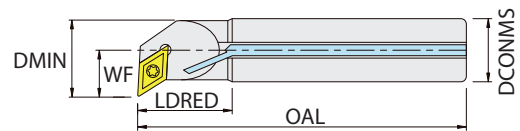
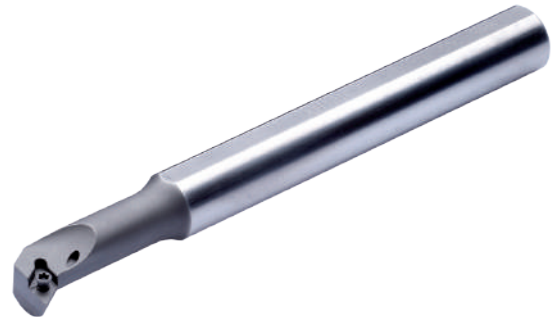
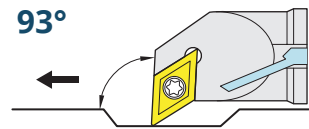

Bestell Nr. Order no. Référence	Wendeplatte Inserts Plaquettes	DCONMS	WF	OAL	LDRED	DMIN
AH0810H.SDUC.R07	DCMT-DCGT 0702..	10	7	100	22	12,5
AH1012K.SDUC.R07	DCMT-DCGT 0702..	12	9	125	28	15,5
AH1216M.SDUC.R07	DCMT-DCGT 0702..	16	11	150	36	19,5

HSS Bohrstangen Satz SDUC R 07 rechts

HSS boring bars set SDUC R 07 right
Set de barres d'alésage HSS SDUC R 07 droite

Bestell Nr. Order no. Référence	Satz beinhaltet Set consist of Set composé
SET.AH.SDUC.R07	AH0810H.SDUC.R07 AH1012K.SDUC.R07 AH1216M.SDUC.R07



10



101.TX8
Torx Klemmschrauben
Torx clamping screw
Torx



02.TX8
Torx-Schraubendreher TX8
Torx screwdriver TX8
Tournevis Torx TX8

K Vollhartmetall Bohrstangen SCLC L 06 links

Carbide boring bars SCLC L 06 left
Barres d'alésage en carbure SCLC L 06 à gauche

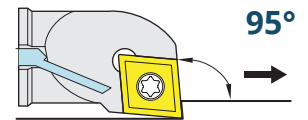

- Schwingungsarme Bohrstangen
- Mit Innenkühlung
- Längere Standzeit der Wendeschneidplatten
- Längsdrehen, sehr gut geeignet für enge Bohrungen
- Anstellwinkel: 95°
- Lieferumfang: Ohne Wendeschneidplatten

- *Low-vibration boring bars*
- *With internal cooling*
- *Longer durability of inserts*
- *For longitudinal and plane turning*
- *Setting angle: 95°*
- *Delivery: without inserts*

- Barres d'alésage à faibles vibrations
- Avec arrosage interne
- Longue durée de vie des plaquettes
- Tournage longitudinale, très bien adapté pour les trous serrés
- Angle d'incidence: 95°
- Livraison: sans plaquettes

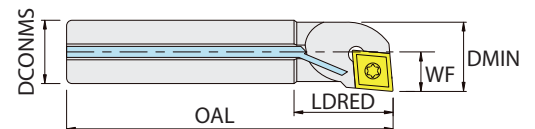

Bestell Nr. Order no. Référence	Wendepatte Inserts Plaquettes	DCONMS	WF	OAL	LDRED	DMIN
E08K.SCLC.L06	CCMT / CCGT 0602...	8	5	125	20	10
E10K.SCLC.L06	CCMT / CCGT 0602...	10	6	125	20	12
E12M.SCLC.L06	CCMT / CCGT 0602...	12	7	150	20	14
E16Q.SCLC.L09	CCMT / CCGT 09T3...	16	7	180	20	14
E16R.SCLC.L09	CCMT / CCGT 09T3...	16	11	200	27	18
E20R.SCLC.L09	CCMT / CCGT 09T3...	20	13	200	27	23
E20S.SCLC.L09	CCMT / CCGT 09T3...	20	13	250	27	23

10

Vollhartmetall Bohrstangen Satz SCLC L 06 links

Carbide boring bars set SCLC L 06 left
Set de barres d'alésage en carbure SCLC L 06 à gauche

Bestell Nr. Order no. Référence	Satz beinhaltet Set consist of Set composé
SET.E.SCLC.L06	E08K.SCLC.L06 E10K.SCLC.L06 E12M.SCLC.L06



101.TX8
Torx Klemmschrauben
Torx clamping screw
Torx



02.TX8
Torx-Schraubendreher TX8
Torx screwdriver TX8
Tournevis Torx TX8

Vollhartmetall Bohrstangen SCLC R 06 rechts



Carbide boring bars SCLC R 06 right
Barres d'alésage en carbure SCLC R 06 droite

- Schwingungsarme Bohrstangen
- Mit Innenkühlung
- Längere Standzeit der Wendeschneidplatten
- Längsdrehen, sehr gut geeignet für enge Bohrungen
- Anstellwinkel: 95°
- Lieferumfang: Ohne Wendeschneidplatten
- *Low-vibration boring bars*
- *With internal cooling*
- *Longer durability of inserts*
- *For longitudinal and plane turning*
- *Setting angle: 95°*
- *Delivery: without inserts*
- Barres d'alésage à faibles vibrations
- Avec arrosage interne
- Longue durée de vie des plaquettes
- Tournage longitudinale, très bien adapté pour les trous serrés
- Angle d'incidence: 95°
- Livraison: sans plaquettes

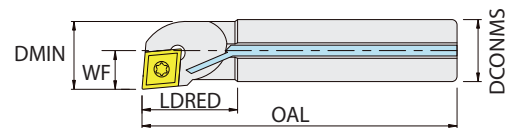
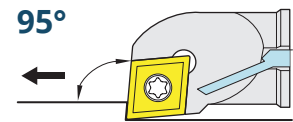

Bestell Nr. Order no. Référence	Wendepatte Inserts Plaquettes	DCONMS	WF	OAL	LDRED	DMIN
E08K.SCLC.R06	CCMT / CCGT 0602...	8	5	125	20	10
E10K.SCLC.R06	CCMT / CCGT 0602...	10	6	125	20	12
E12M.SCLC.R06	CCMT / CCGT 0602...	12	7	150	20	14
E16Q.SCLC.R09	CCMT / CCGT 09T3...	16	7	180	20	14
E16R.SCLC.R09	CCMT / CCGT 09T3...	16	11	200	27	18
E20R.SCLC.R09	CCMT / CCGT 09T3...	20	13	200	27	23
E20S.SCLC.R09	CCMT / CCGT 09T3...	20	13	250	27	23

10

Vollhartmetall Bohrstangen Satz SCLC R 06 rechts

Carbide boring bars set SCLC R 06 right
Set de barres d'alésage en carbure SCLC R 06 droite

Bestell Nr. Order no. Référence	Satz beinhaltet Set consist of Set composé
SET.E.SCLC.R06	E08K.SCLC.R06 E10K.SCLC.R06 E12M.SCLC.R06



101.TX8
Torx Klemmschrauben
Torx clamping screw
Torx



02.TX8
Torx-Schraubendreher TX8
Torx screwdriver TX8
Tournevis Torx TX8

K Vollhartmetall Bohrstangen SDUC L 07 links

Carbide boring bars SDUC L 07 left
Barres d'alésage en carbure SDUC L 07 à gauche

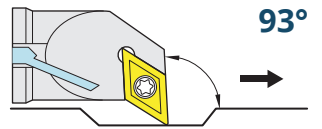

- Schwingungsarme Bohrstangen
- Mit Innenkühlung
- Längere Standzeit der Wendeschneidplatten
- Längsdrehen, sehr gut geeignet für enge Bohrungen
- Anstellwinkel: 93°
- Lieferumfang: Ohne Wendeschneidplatten

- *Low-vibration boring bars*
- *With internal cooling*
- *Longer durability of inserts*
- *For longitudinal and plane turning*
- *Setting angle: 93°*
- *Delivery: without inserts*

- Barres d'alésage à faibles vibrations
- Avec arrosage interne
- Longue durée de vie des plaquettes
- Tournage longitudinale, très bien adapté pour les trous serrés
- Angle d'incidence: 93°
- Livraison: sans plaquettes

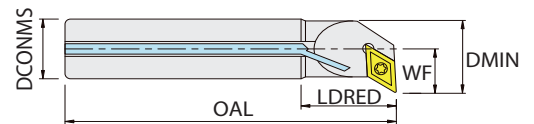

Bestell Nr. Order no. Référence	Wendeplatte Inserts Plaquettes	DCONMS	WF	OAL	LDRED	DMIN
E10K.SDUC.L07	DCMT-DCGT 0702..	10	8,3	125	20	14
E12M.SDUC.L07	DCMT-DCGT 0702..	12	9,3	150	20	16
E16Q.SDUC.L07	DCMT-DCGT 0702..	16	11,5	180	25	20
E16R.SDUC.L07	DCMT-DCGT 0702..	16	11,5	200	25	20
E20R.SDUC.L11	DCMT-DCGT 11T3..	20	16,5	200	30	27
E20S.SDUC.L11	DCMT-DCGT 11T3..	20	16,5	250	30	27

10

Vollhartmetall Bohrstangen Satz SDUC L 07 links

Carbide boring bars set SDUC L 07 left
Set de barres d'alésage en carbure SDUC L 07 à gauche

Bestell Nr. Order no. Référence	Satz beinhaltet Set consist of Set composé
SET.E.SDUC.L07	E10K.SDUC.L07 E12M.SDUC.L07



101.TX8
Torx Klemmschrauben
Torx clamping screw
Torx



02.TX8
Torx-Schraubendreher TX8
Torx screwdriver TX8
Tournevis Torx TX8

Vollhartmetall Bohrstangen SDUC R 07 rechts



Carbide boring bars SDUC R 07 right
Barres d'alésage en carbure SDUC R 07 droite

- Schwingungsarme Bohrstangen
- Mit Innenkühlung
- Längere Standzeit der Wendeschneidplatten
- Längsdrehen, sehr gut geeignet für enge Bohrungen
- Anstellwinkel: 93°
- Lieferumfang: Ohne Wendeschneidplatten

- *Low-vibration boring bars*
- *With internal cooling*
- *Longer durability of inserts*
- *For longitudinal and plane turning*
- *Setting angle: 93°*
- *Delivery: without inserts*

- Barres d'alésage à faibles vibrations
- Avec arrosage interne
- Longue durée de vie des plaquettes
- Tournage longitudinale, très bien adapté pour les trous serrés
- Angle d'incidence: 93°
- Livraison: sans plaquettes

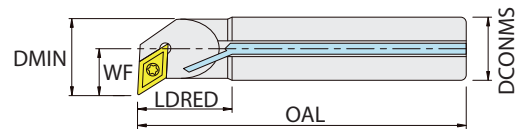
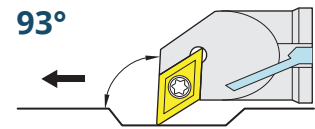

Bestell Nr. Order no. Référence	Wendepatte Inserts Plaquettes	DCONMS	DCONMS	OAL	LDRED	DMIN
E10K.SDUC.R07	DCMT-DCGT 0702..	10	8,3	125	20	14
E12M.SDUC.R07	DCMT-DCGT 0702..	12	9,3	150	20	16
E16Q.SDUC.R07	DCMT-DCGT 0702..	16	11,5	180	25	20
E16R.SDUC.R07	DCMT-DCGT 0702..	16	11,5	200	25	20
E20R.SDUC.R11	DCMT-DCGT 11T3..	20	16,5	200	30	27
E20S.SDUC.R11	DCMT-DCGT 11T3..	20	16,5	250	30	27

10

Vollhartmetall Bohrstangen Satz SDUC R 07 rechts

Carbide boring bars set SDUC R 07 right
Set de barres d'alésage en carbure SDUC R 07 droite

Bestell Nr. Order no. Référence	Satz beinhaltet Set consist of Set composé
SET.E.SDUC.R07	E10K.SDUC.R07 E12M.SDUC.R07



101.TX8
Torx Klemmschrauben
Torx clamping screw
Torx



02.TX8
Torx-Schraubendreher TX8
Torx screwdriver TX8
Tournevis Torx TX8

K Vollhartmetall Bohrstangen SDQC L 07 links

Carbide boring bars SDQC L 07 left
Barres d'alésage en carbure SDQC L 07 à gauche

- Schwingungsarme Bohrstangen
- Mit Innenkühlung
- Längere Standzeit der Wendeschneidplatten
- Längsdrehen, sehr gut geeignet für enge Bohrungen
- Anstellwinkel: 107,5°
- Lieferumfang: Ohne Wendeschneidplatten

- *Low-vibration boring bars*
- *With internal cooling*
- *Longer durability of inserts*
- *For longitudinal and plane turning*
- *Setting angle: 107,5°*
- *Delivery: without inserts*

- Barres d'alésage à faibles vibrations
- Avec arrosage interne
- Longue durée de vie des plaquettes
- Tournage longitudinale, très bien adapté pour les trous serrés
- Angle d'incidence: 107,5°
- Livraison: sans plaquettes

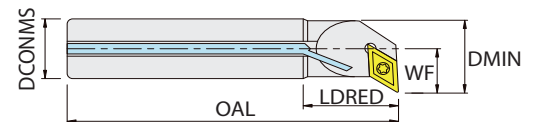

Bestell Nr. Order no. Référence	Wendepatte Inserts Plaquettes	DCONMS	WF	OAL	LDRED	DMIN
E08K.SDQC.L07	DCMT-DCGT 0702..	8	7	125	20	11,5
E10K.SDQC.L07	DCMT-DCGT 0702..	10	8	125	20	13
E12M.SDQC.L07	DCMT-DCGT 0702..	12	9	150	20	16
E16Q.SDQC.L07	DCMT-DCGT 0702..	16	11,5	180	25	20
E16R.SDQC.L07	DCMT-DCGT 0702..	16	11,5	200	25	20
E20R.SDQC.L11	DCMT-DCGT 11T3..	20	14,5	200	30	25
E20S.SDQC.L11	DCMT-DCGT 11T3..	20	14,5	250	30	25

10

Vollhartmetall Bohrstangen Satz SDQC L 07 links

Carbide boring bars set SDQC L 07 left
Set de barres d'alésage en carbure SDQC L 07 à gauche

Bestell Nr. Order no. Référence	Satz beinhaltet Set consist of Jeu composé
SET.E.SDQC.L07	E08K.SDQC.L07 E10K.SDQC.L07 E12M.SDQC.L07



101.TX8
Torx Klemmschrauben
Torx clamping screw
Torx



02.TX8
Torx-Schraubendreher TX8
Torx screwdriver TX8
Tournevis Torx TX8

Vollhartmetall Bohrstangen SDQC R 07 rechts



Carbide boring bars SDQC R 07 right
Barres d'alésage en carbure SDQC R 07 droite

- Schwingungsarme Bohrstangen
- Mit Innenkühlung
- Längere Standzeit der Wendeschneidplatten
- Längsdrehen, sehr gut geeignet für enge Bohrungen
- Anstellwinkel: 107,5°
- Lieferumfang: Ohne Wendeschneidplatten

- *Low-vibration boring bars*
- *With internal cooling*
- *Longer durability of inserts*
- *For longitudinal and plane turning*
- *Setting angle: 107,5°*
- *Delivery: without inserts*

- Barres d'alésage à faibles vibrations
- Avec arrosage interne
- Longue durée de vie des plaquettes
- Tournage longitudinale, très bien adapté pour les trous serrés
- Angle d'incidence: 107,5°
- Livraison: sans plaquettes

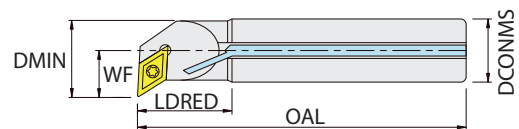

Bestell Nr. Order no. Référence	Wendeplatte Inserts Plaquettes	DCONMS	WF	OAL	LDRED	DMIN
E08K.SDQC.R07	DCMT-DCGT 0702..	8	7	125	20	11,5
E10K.SDQC.R07	DCMT-DCGT 0702..	10	8	125	20	13
E12M.SDQC.R07	DCMT-DCGT 0702..	12	9	150	20	16
E16Q.SDQC.R07	DCMT-DCGT 0702..	16	11,5	180	25	20
E16R.SDQC.R07	DCMT-DCGT 0702..	16	11,5	200	25	20
E20R.SDQC.R11	DCMT-DCGT 11T3..	20	14,5	200	30	25
E20S.SDQC.R11	DCMT-DCGT 11T3..	20	14,5	250	30	25

Vollhartmetall Bohrstangen Satz SDQC R 07 rechts

Carbide boring bars set SDQC R 07 right
Set de barres d'alésage en carbure SDQC R 07 droite

Bestell Nr. Order no. Référence	Satz beinhaltet Set consist of Jeu composé
SET.E.SDQC.R07	E08K.SDQC.R07 E10K.SDQC.R07 E12M.SDQC.R07



101.TX8
Torx Klemmschrauben
Torx clamping screw
Torx



02.TX8
Torx-Schraubendreher TX8
Torx screwdriver TX8
Tournevis Torx TX8



HSS-E Gewindebohrer Metrisches ISO-Gewinde für Grundlochgewinde

HSS-E spiral flute taps for multi-purpose ISO metric coarse threads for blind holes
Taraud HSS-E avec filetage métrique pour filetage trou borgne



1. Gewinde in spezieller Ausführung, verhindert zu großen Vorschub, dünnes Gewinde und zu große Steigung.
2. Nutenform in spezieller Ausführung, bessere Spanabfuhr, kein Spänestau, verbessert die Gewindequalität
3. Hervorragende Leistung in vielen Werkstoffen: rostfreie Stähle, Kohlenstoffstähle, legierte Stähle, Werkzeugstähle

1. Thread configuration with a special design, prevents overfeeding, thin thread and pitch diameter oversize.
2. Flute geometry with special design, better chip evacuation, prevents chip clogging, improves thread quality
3. Excellent performance on various work material: Stainless steel, carbon steel, alloyed steel, tool steel

1. Filetage en conception spéciale, empêche avancement excessive, filetage mince et de pente grande.
2. Flûte en exécution spéciale, meilleure évacuation des copeaux, pas de congestion de copeaux, amélioration de la qualité du filetage
3. Excellente performance dans de nombreux matériaux: aciers inoxydables, aciers au carbone, aciers alliés, aciers à outils

Bestell Nr. Order no. Référence	TDZ	TP	OAL	THL	DCONMS	DRVS	 \emptyset mm PHD	Norm
C.2050.M2.0	M2	0,4	45,0	6,0	2,8	2,1	1,6	DIN 371
C.2050.M2.5	M2.5	0,45	50,0	7,5	2,8	2,1	2,05	DIN 371
C.2050.M3.0	M3	0,5	56,0	6,0	3,5	2,7	2,5	DIN 371
C.2050.M3.5	M3.5	0,6	56,0	7,0	4,0	3,0	2,9	DIN 371
C.2050.M4.0	M4	0,7	63,0	7,0	4,5	3,4	3,3	DIN 371
C.2050.M5.0	M5	0,8	70,0	8,0	6,0	4,9	4,2	DIN 371
C.2050.M6.0	M6	1,0	80,0	10,0	6,0	4,9	5,0	DIN 371
C.2050.M8.0	M8	1,25	90,0	13,0	8,0	6,2	6,8	DIN 371
C.2050.M10.0	M10	1,5	100,0	15,0	10,0	8,0	8,5	DIN 371
C.4050.M12.0	M12	1,75	110,0	18,0	9,0	7,0	10,2	DIN 376
C.4050.M14.0	M14	2,0	110,0	20,0	11,0	9,0	12,0	DIN 376
C.4050.M16.0	M16	2,0	110,0	20,0	12,0	9,0	14,0	DIN 376
C.4050.M18.0	M18	2,5	125,0	25,0	14,0	11,0	15,5	DIN 376
C.4050.M20.0	M20	2,5	140,0	25,0	16,0	12,0	17,5	DIN 376
C.4050.M22.0	M22	2,5	140,0	25,0	18,0	14,0	19,5	DIN 376
C.4050.M24.0	M24	3,0	160,0	30,0	18,0	14,0	21,0	DIN 376
C.4050.M27.0	M27	3,0	160,0	30,0	20,0	16,0	24,0	DIN 376
C.4050.M30.0	M30	3,5	180,0	35,0	22,0	18,0	26,5	DIN 376
C.4050.M33.0	M33	3,5	180,0	35,0	25,0	20,0	29,5	DIN 376
C.4050.M36.0	M36	4,0	200,0	40,0	28,0	22,0	32,0	DIN 376



HSS-E spiral flute taps for multi-purpose ISO metric coarse threads for blind holes

Taraud HSS-E avec filetage métrique pour filetage trou borgne



TiN Titanium Nitrid beschichtet
Titanitrid coating
Revêtue de nitrure de titane

1. Gewinde in spezieller Ausführung, verhindert zu großen Vorschub, dünnes Gewinde und zu große Steigung.
2. Nutenform in spezieller Ausführung, bessere Spanabfuhr, kein Spänestau, verbessert die Gewindequalität
3. Hervorragende Leistung in vielen Werkstoffen: rostfreie Stähle, Kohlenstoffstähle, legierte Stähle, Werkzeugstähle

1. Thread configuration with a special design, prevents overfeeding, thin thread and pitch diameter oversize.

2. Flute geometry with special design, better chip evacuation, prevents chip clogging, improves thread quality

3. Excellent performance on various work material: Stainless steel, carbon steel, alloyed steel, tool steel

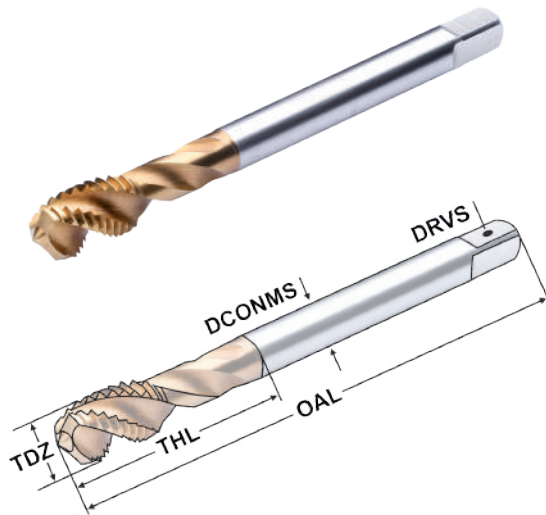

1. Filetage en conception spéciale, empêche avancement excessive, filetage mince et de pente grande.

2. Flûte en exécution spéciale, meilleure évacuation des copeaux, pas de congestion de copeaux, amélioration de la qualité du filetage

3. Excellente performance dans de nombreux matériaux: aciers inoxydables, aciers au carbone, aciers alliés, aciers à outils

Bestell Nr. Order no. Référence	TDZ	TP	OAL	THL	DCONMS	DRVS	Ø mm PHD	Norm
TC.2060.M2.0	M2	0,4	45,0	6,0	2,8	2,1	1,6	DIN 371
TC.2060.M2.5	M2,5	0,45	50,0	7,5	2,8	2,1	2,05	DIN 371
TC.2060.M3.0	M3	0,5	56,0	6,0	3,5	2,7	2,5	DIN 371
TC.2060.M3.5	M3,5	0,6	56,0	7,0	4,0	3,0	2,9	DIN 371
TC.2060.M4.0	M4	0,7	63,0	7,0	4,5	3,4	3,3	DIN 371
TC.2060.M5.0	M5	0,8	70,0	8,0	6,0	4,9	4,2	DIN 371
TC.2060.M6.0	M6	1,0	80,0	10,0	6,0	4,9	5,0	DIN 371
TC.2060.M8.0	M8	1,25	90,0	13,0	8,0	6,2	6,8	DIN 371
TC.2060.M10.0	M10	1,5	100,0	15,0	10,0	8,0	8,5	DIN 371
TC.4060.M12.0	M12	1,75	110,0	18,0	9,0	7,0	10,2	DIN 376
TC.4060.M14.0	M14	2,0	110,0	20,0	11,0	9,0	12,0	DIN 376
TC.4060.M16.0	M16	2,0	110,0	20,0	12,0	9,0	14,0	DIN 376
TC.4060.M18.0	M18	2,5	125,0	25,0	14,0	11,0	15,5	DIN 376
TC.4060.M20.0	M20	2,5	140,0	25,0	16,0	12,0	17,5	DIN 376
TC.4060.M22.0	M22	2,5	140,0	25,0	18,0	14,0	19,5	DIN 376
TC.4060.M24.0	M24	3,0	160,0	30,0	18,0	14,0	21,0	DIN 376
TC.4060.M27.0	M27	3,0	160,0	30,0	20,0	16,0	24,0	DIN 376
TC.4060.M30.0	M30	3,5	180,0	35,0	22,0	18,0	26,5	DIN 376
TC.4060.M33.0	M33	3,5	180,0	35,0	25,0	20,0	29,5	DIN 376
TC.4060.M36.0	M36	4,0	200,0	40,0	28,0	22,0	32,0	DIN 376





HSS-E Gewindebohrer Metrisches ISO-Gewinde für Durchgangsgewinde

HSS-E spiral flute taps for multi-purpose ISO metric coarse threads for through holes

Taraud HSS-E avec filetage métrique pour filetage trou de passage



1. Gewinde in spezieller Ausführung, verhindert zu großen Vorschub, dünnes Gewinde und zu große Steigung.
2. Nutenform in spezieller Ausführung, bessere Spanabfuhr, kein Spänestau, verbessert die Gewindequalität
3. Hervorragende Leistung in vielen Werkstoffen: rostfreie Stähle, Kohlenstoffstähle, legierte Stähle, Werkzeugstähle

1. Thread configuration with a special design, prevents overfeeding, thin thread and pitch diameter oversize.

2. Flute geometry with special design, better chip evacuation, prevents chip clogging, improves thread quality

3. Excellent performance on various work material: Stainless steel, carbon steel, alloyed steel, tool steel

1. Filetage en conception spéciale, empêche avancement excessive, filetage mince et de pente grande.

2. Flûte en exécution spéciale, meilleure évacuation des copeaux, pas de congestion de copeaux, amélioration de la qualité du filetage

3. Excellente performance dans de nombreux matériaux: aciers inoxydables, aciers au carbone, aciers alliés, aciers à outils

Bestell Nr. Order no. Référence	TDZ	TP	OAL	THL	DCONMS	DRVS	 mm PHD	Norm
B.1500.M2.0	M2	0,4	45,0	8,0	2,8	2,1	1,6	DIN 371
B.1500.M2.5	M2,5	0,45	50,0	9,0	2,8	2,1	2,05	DIN 371
B.1500.M3.0	M3	0,5	56,0	11,0	3,5	2,7	2,5	DIN 371
B.1500.M3.5	M3,5	0,6	56,0	12,0	4,0	3,0	2,9	DIN 371
B.1500.M4.0	M4	0,7	63,0	13,0	4,5	3,4	3,3	DIN 371
B.1500.M5.0	M5	0,8	70,0	15,0	6,0	4,9	4,2	DIN 371
B.1500.M6.0	M6	1,0	80,0	15,0	6,0	4,9	5,0	DIN 371
B.1500.M8.0	M8	1,25	90,0	20,0	8,0	6,2	6,8	DIN 371
B.1500.M10.0	M10	1,5	100,0	22,0	10,0	8,0	8,5	DIN 371
B.3500.M12.0	M12	1,75	110,0	24,0	9,0	7,0	10,2	DIN 376
B.3500.M14.0	M14	2,0	110,0	26,0	11,0	9,0	12,0	DIN 376
B.3500.M16.0	M16	2,0	110,0	27,0	12,0	9,0	14,0	DIN 376
B.3500.M18.0	M18	2,5	125,0	30,0	14,0	11,0	15,5	DIN 376
B.3500.M20.0	M20	2,5	140,0	32,0	16,0	12,0	17,5	DIN 376
B.3500.M22.0	M22	2,5	140,0	32,0	18,0	14,0	19,5	DIN 376
B.3500.M24.0	M24	3,0	160,0	34,0	18,0	14,0	21,0	DIN 376
B.3500.M27.0	M27	3,0	160,0	36,0	20,0	16,0	24,0	DIN 376
B.3500.M30.0	M30	3,5	180,0	40,0	22,0	18,0	26,5	DIN 376
B.3500.M33.0	M33	3,5	180,0	42,0	25,0	20,0	29,5	DIN 376
B.3500.M36.0	M36	3,5	200,0	50,0	28,0	22,0	32,0	DIN 376

10



HSS-E spiral flute taps for multi-purpose ISO metric coarse threads for through holes

Taraud HSS-E avec filetage métrique pour filetage trou de passage





TiN Titanium Nitrid beschichtet
Titannitrid coating
Revêtue de nitrure de titane

1. Gewinde in spezieller Ausführung, verhindert zu großen Vorschub, dünnes Gewinde und zu große Steigung.
2. Nutenform in spezieller Ausführung, bessere Spanabfuhr, kein Spänestau, verbessert die Gewindequalität
3. Hervorragende Leistung in vielen Werkstoffen: rostfreie Stähle, Kohlenstoffstähle, legierte Stähle, Werkzeugstähle

1. Thread configuration with a special design, prevents overfeeding, thin thread and pitch diameter oversize.
2. Flute geometry with special design, better chip evacuation, prevents chip clogging, improves thread quality
3. Excellent performance on various work material: Stainless steel, carbon steel, alloyed steel, tool steel

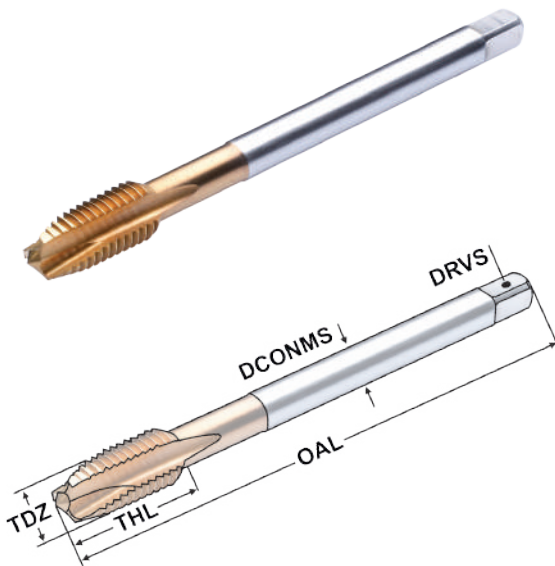
1. Filetage en conception spéciale, empêche avancement excessive, filetage mince et de pente grande.
2. Flûte en exécution spéciale, meilleure évacuation des copeaux, pas de congestion de copeaux, amélioration de la qualité du filetage
3. Excellente performance dans de nombreux matériaux: aciers inoxydables, aciers au carbone, aciers alliés, aciers à outils



Bestell Nr. Order no. Référence	TDZ	TP	OAL	THL	DCONMS	DRVS	 Ø mm PHD	Norm
TB.1510.M2.0	M2	0,4	45,0	8,0	2,8	2,1	1,6	DIN 371
TB.1510.M2.5	M2,5	0,45	50,0	9,0	2,8	2,1	2,05	DIN 371
TB.1510.M3.0	M3	0,5	56,0	11,0	3,5	2,7	2,5	DIN 371
TB.1510.M3.5	M3,5	0,6	56,0	12,0	4,0	3,0	2,9	DIN 371
TB.1510.M4.0	M4	0,7	63,0	13,0	4,5	3,4	3,3	DIN 371
TB.1510.M5.0	M5	0,8	70,0	15,0	6,0	4,9	4,2	DIN 371
TB.1510.M6.0	M6	1,0	80,0	15,0	6,0	4,9	5,0	DIN 371
TB.1510.M8.0	M8	1,25	90,0	20,0	8,0	6,2	6,8	DIN 371
TB.1510.M10.0	M10	1,5	100,0	22,0	10,0	8,0	8,5	DIN 371
TB.3510.M12.0	M12	1,75	110,0	24,0	9,0	7,0	10,2	DIN 376
TB.3510.M14.0	M14	2,0	110,0	26,0	11,0	9,0	12,0	DIN 376
TB.3510.M16.0	M16	2,0	110,0	27,0	12,0	9,0	14,0	DIN 376
TB.3510.M18.0	M18	2,5	125,0	30,0	14,0	11,0	15,5	DIN 376
TB.3510.M20.0	M20	2,5	140,0	32,0	16,0	12,0	17,5	DIN 376
TB.3510.M22.0	M22	2,5	140,0	32,0	18,0	14,0	19,5	DIN 376
TB.3510.M24.0	M24	3,0	160,0	34,0	18,0	14,0	21,0	DIN 376
TB.3510.M27.0	M27	3,0	160,0	36,0	20,0	16,0	24,0	DIN 376
TB.3510.M30.0	M30	3,5	180,0	40,0	22,0	18,0	26,5	DIN 376
TB.3510.M33.0	M33	3,5	180,0	42,0	25,0	20,0	29,5	DIN 376
TB.3510.M36.0	M36	3,5	200,0	50,0	28,0	22,0	32,0	DIN 376

10





HSS-E Gewindebohrer Metrisches ISO-Feingewinde für Grundlochgewinde

HSS-E spiral flute taps for multi-purpose ISO metric fine threads for blind holes

Taraud HSS-E avec filetage métrique fin pour filetage trou borgne

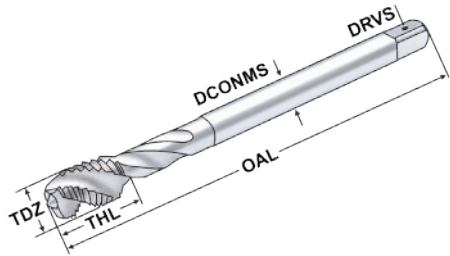

1. Gewinde in spezieller Ausführung, verhindert zu großen Vorschub, dünnes Gewinde und zu große Steigung.
2. Nutenform in spezieller Ausführung, bessere Spanabfuhr, kein Spänestau, verbessert die Gewindequalität
3. Hervorragende Leistung in vielen Werkstoffen: rostfreie Stähle, Kohlenstoffstähle, legierte Stähle, Werkzeugstähle

1. Thread configuration with a special design, prevents overfeeding, thin thread and pitch diameter oversize.
2. Flute geometry with special design, better chip evacuation, prevents chip clogging, improves thread quality
3. Excellent performance on various work material: Stainless steel, carbon steel, alloyed steel, tool steel

1. Filetage en conception spéciale, empêche avancement excessive, filetage mince et de pente grande.
2. Flûte en exécution spéciale, meilleure évacuation des copeaux, pas de congestion de copeaux, amélioration de la qualité du filetage
3. Excellente performance dans de nombreux matériaux: aciers inoxydables, aciers au carbone, aciers alliés, aciers à outils

10

Bestell Nr. Order no. Référence	TDZ	TP	OAL	THL	DCONMS	DRVS	Ø mm PHD
FC.4050.M4.0	M4	0,5	63	7	2,8	2,1	3,5
FC.4050.M5.0	M5	0,5	80	8	3,5	2,7	4,5
FC.4050.M6.1	M6	0,75	80	10	4,5	3,4	5,2
FC.4050.M6.2	M6	0,5	80	10	4,5	3,4	5,5
FC.4050.M7.0	M7	0,75	80	10	5,5	4,3	6,2
FC.4050.M8.1	M8	1	90	13	6,0	4,9	7,0
FC.4050.M8.2	M8	0,75	80	10	6,0	4,9	7,2
FC.4050.M9.0	M9	1	90	13	7,0	5,5	8,0
FC.4050.M10.1	M10	1,25	100	15	7,0	5,5	8,8
FC.4050.M10.2	M10	1	90	12	7,0	5,5	9,0
FC.4050.M10.3	M10	0,75	90	12	7,0	5,5	9,2
FC.4050.M11	M11	1	90	12	8,0	6,2	10,0
FC.4050.M12.1	M12	1,5	100	14	9,0	7,0	10,5
FC.4050.M12.2	M12	1,25	100	14	9,0	7,0	10,8
FC.4050.M12.3	M12	1	100	14	9,0	7,0	11,0
FC.4050.M14.1	M14	1,5	100	16	11,0	9,0	12,5
FC.4050.M14.2	M14	1,25	100	16	11,0	9,0	12,8
FC.4050.M14.3	M14	1	100	16	11,0	9,0	13,0
FC.4050.M15	M15	1	100	16	12,0	9,0	14,0
FC.4050.M16.1	M16	1,5	100	16	12,0	9,0	14,5
FC.4050.M16.2	M16	1	100	16	12,0	9,0	15,0



HSS-E spiral flute taps for multi-purpose ISO metric fine threads for blind holes

Taraud HSS-E avec filetage métrique fin pour filetage trou borgne



TiN Titanium Nitrid beschichtet
Titannitrid coating
Revêtue de nitrure de titane

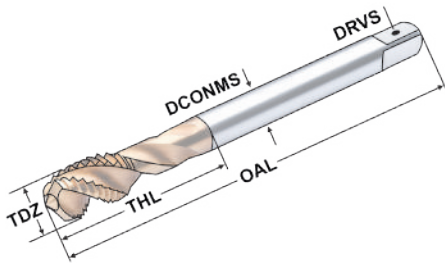
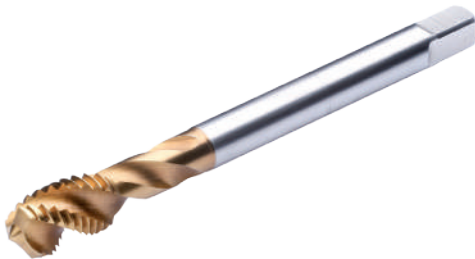

1. Gewinde in spezieller Ausführung, verhindert zu großen Vorschub, dünnes Gewinde und zu große Steigung.

2. Nutenform in spezieller Ausführung, bessere Spanabfuhr, kein Spänestau, verbessert die Gewindequalität

3. Hervorragende Leistung in vielen Werkstoffen: rostfreie Stähle, Kohlenstoffstähle, legierte Stähle, Werkzeugstähle

1. Thread configuration with a special design, prevents overfeeding, thin thread and pitch diameter oversize.

2. Flute geometry with special design, better chip evacuation, prevents chip clogging, improves thread quality

3. Excellent performance on various work material: Stainless steel, carbon steel, alloyed steel, tool steel

1. Filetage en conception spéciale, empêche avancement excessive, filetage mince et de pente grande.

2. Flûte en exécution spéciale, meilleure évacuation des copeaux, pas de congestion de copeaux, amélioration de la qualité du filetage

3. Excellente performance dans de nombreux matériaux: aciers inoxydables, aciers au carbone, aciers alliés, aciers à outils

Bestell Nr. Order no. Référence	TDZ	TP	OAL	THL	DCONMS	DRVS	 mm PHD
TFC.4060.M4.0	M4	0,5	63	7	2,8	2,1	3,5
TFC.4060.M5.0	M5	0,5	80	8	3,5	2,7	4,5
TFC.4060.M6.1	M6	0,75	80	10	4,5	3,4	5,2
TFC.4060.M6.2	M6	0,5	80	10	4,5	3,4	5,5
TFC.4060.M7.0	M7	0,75	80	10	5,5	4,3	6,2
TFC.4060.M8.1	M8	1	90	13	6,0	4,9	7,0
TFC.4060.M8.2	M8	0,75	80	10	6,0	4,9	7,2
TFC.4060.M9.0	M9	1	90	13	7,0	5,5	8,0
TFC.4060.M10.1	M10	1,25	100	15	7,0	5,5	8,8
TFC.4060.M10.2	M10	1	90	12	7,0	5,5	9,0
TFC.4060.M10.3	M10	0,75	90	12	7,0	5,5	9,2
TFC.4060.M11	M11	1	90	12	8,0	6,2	10,0
TFC.4060.M12.1	M12	1,5	100	14	9,0	7,0	10,5
TFC.4060.M12.2	M12	1,25	100	14	9,0	7,0	10,8
TFC.4060.M12.3	M12	1	100	14	9,0	7,0	11,0
TFC.4060.M14.1	M14	1,5	100	16	11,0	9,0	12,5
TFC.4060.M14.2	M14	1,25	100	16	11,0	9,0	12,8
TFC.4060.M14.3	M14	1	100	16	11,0	9,0	13,0
TFC.4060.M15	M15	1	100	16	12,0	9,0	14,0
TFC.4060.M16.1	M16	1,5	100	16	12,0	9,0	14,5
TFC.4060.M16.2	M16	1	100	16	12,0	9,0	15,0

10



HSS-E Gewindebohrer Metrisches ISO-Feingewinde für Durchgangsgewinde

HSS-E spiral flute taps for multi-purpose ISO metric fine threads for through holes
 Taraud HSS-E avec filetage métrique fin pour filetage trou de passage

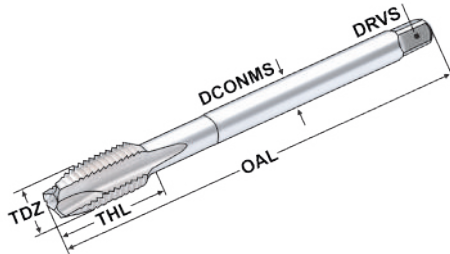

1. Gewinde in spezieller Ausführung, verhindert zu großen Vorschub, dünnes Gewinde und zu große Steigung.
2. Nutenform in spezieller Ausführung, bessere Spanabfuhr, kein Spänestau, verbessert die Gewindequalität
3. Hervorragende Leistung in vielen Werkstoffen: rostfreie Stähle, Kohlenstoffstähle, legierte Stähle, Werkzeugstähle

1. Thread configuration with a special design, prevents overfeeding, thin thread and pitch diameter oversize.

2. Flute geometry with special design, better chip evacuation, prevents chip clogging, improves thread quality

3. Excellent performance on various work material: Stainless steel, carbon steel, alloyed steel, tool steel

1. Filetage en conception spéciale, empêche avancement excessive, filetage mince et de pente grande.

2. Flûte en exécution spéciale, meilleure évacuation des copeaux, pas de congestion de copeaux, amélioration de la qualité du filetage

3. Excellente performance dans de nombreux matériaux: aciers inoxydables, aciers au carbone, aciers alliés, aciers à outils

Bestell Nr. Order no. Référence	TDZ	TP	OAL	THL	DCONMS	DRVS	Ø mm PHD
FB.3500.M4.0	M4	0,5	63	12	2,8	2,1	3,5
FB.3500.M5.0	M5	0,5	70	13	3,5	2,7	4,5
FB.3500.M6.1	M6	0,75	80	15	4,5	3,4	5,2
FB.3500.M6.2	M6	0,5	80	15	4,5	3,4	5,5
FB.3500.M7.0	M7	0,75	80	15	5,5	4,3	6,2
FB.3500.M8.1	M8	1,0	90	18	6,0	4,9	7,0
FB.3500.M8.2	M8	0,75	80	15	6,0	4,9	7,2
FB.3500.M10.1	M10	1,25	100	20	7,0	5,5	8,8
FB.3500.M10.2	M10	1,0	90	20	7,0	5,5	9,0
FB.3500.M10.3	M10	0,75	90	20	7,0	5,5	9,2
FB.3500.M12.1	M12	1,5	100	21	9,0	7,0	10,5
FB.3500.M12.2	M12	1,25	100	21	9,0	7,0	10,8
FB.3500.M12.3	M12	1,0	100	21	9,0	7,0	11,0
FB.3500.M14.1	M14	1,5	100	21	11,0	9,0	12,5
FB.3500.M14.2	M14	1,25	100	21	11,0	9,0	12,8
FB.3500.M14.3	M14	1,0	100	21	11,0	9,0	13,0
FB.3500.M15.1	M15	1,5	100	21	12,0	9,0	13,5
FB.3500.M15.2	M15	1,0	100	21	12,0	9,0	14,0
FB.3500.M16.1	M16	1,5	100	21	12,0	9,0	14,5
FB.3500.M16.2	M16	1,0	100	21	12,0	9,0	15,0



HSS-E spiral flute taps for multi-purpose ISO metric fine threads for through holes

Taraud HSS-E avec filetage métrique fin pour filetage trou de passage



TiN Titanium Nitrid beschichtet
Titannitrid coating
 Revêtue de nitrure de titane

1. Gewinde in spezieller Ausführung, verhindert zu großen Vorschub, dünnes Gewinde und zu große Steigung.

2. Nutenform in spezieller Ausführung, bessere Spanabfuhr, kein Spänestau, verbessert die Gewindegüte

3. Hervorragende Leistung in vielen Werkstoffen: rostfreie Stähle, Kohlenstoffstähle, legierte Stähle, Werkzeugstähle

1. Thread configuration with a special design, prevents over-feeding, thin thread and pitch diameter oversize.

2. Flute geometry with special design, better chip evacuation, prevents chip clogging, improves thread quality

3. Excellent performance on various work material: Stainless steel, carbon steel, alloyed steel, tool steel

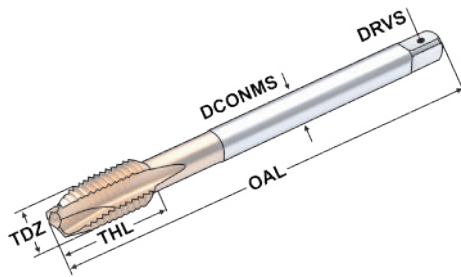
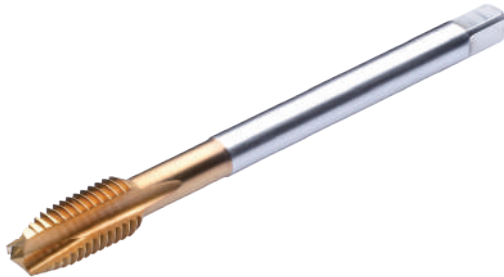

1. Filetage en conception spéciale, empêche avancement excessive, filetage mince et de pente grande.

2. Flûte en exécution spéciale, meilleure évacuation des copeaux, pas de congestion de copeaux, amélioration de la qualité du filetage

3. Excellente performance dans de nombreux matériaux: aciers inoxydables, aciers au carbone, aciers alliés, aciers à outils

Bestell Nr. Order no. Référence	TDZ	TP	OAL	THL	DCONMS	DRVS	\emptyset mm PHD
TFB.3510.M4.0	M4	0,5	63	12	2,8	2,1	3,5
TFB.3510.M5.0	M5	0,5	70	13	3,5	2,7	4,5
TFB.3510.M6.1	M6	0,75	80	15	4,5	3,4	5,2
TFB.3510.M6.2	M6	0,5	80	15	4,5	3,4	5,5
TFB.3510.M7.0	M7	0,75	80	15	5,5	4,3	6,2
TFB.3510.M8.1	M8	1,0	90	18	6,0	4,9	7,0
TFB.3510.M8.2	M8	0,75	80	15	6,0	4,9	7,2
TFB.3510.M10.1	M10	1,25	100	20	7,0	5,5	8,8
TFB.3510.M10.2	M10	1,0	90	20	7,0	5,5	9,0
TFB.3510.M10.3	M10	0,75	90	20	7,0	5,5	9,2
TFB.3510.M12.1	M12	1,5	100	21	9,0	7,0	10,5
TFB.3510.M12.2	M12	1,25	100	21	9,0	7,0	10,8
TFB.3510.M12.3	M12	1,0	100	21	9,0	7,0	11,0
TFB.3510.M14.1	M14	1,5	100	21	11,0	9,0	12,5
TFB.3510.M14.2	M14	1,25	100	21	11,0	9,0	12,8
TFB.3510.M14.3	M14	1,0	100	21	11,0	9,0	13,0
TFB.3510.M15.1	M15	1,5	100	21	12,0	9,0	13,5
TFB.3510.M15.2	M15	1,0	100	21	12,0	9,0	14,0
TFB.3510.M16.1	M16	1,5	100	21	12,0	9,0	14,5
TFB.3510.M16.2	M16	1,0	100	21	12,0	9,0	15,0

10



K HSS-E Gewindebohrer Satz Metrisches ISO-Gewinde für Grundlochgewinde

Set of HSS-E spiral flute taps for multi-purpose ISO metric coarse threads for blind holes
 Set de tarauds HSS-E avec filetage métrique pour filetage trou borgne



Bestell Nr. Order no. Référence	Abmessung Size Dimension
C.2050-S	(7tlg.) M3-M4-M5-M6-M8-M10-M12

HSS-E Gewindebohrer Satz Metrisches ISO-Gewinde für Grundlochgewinde

Set of HSS-E spiral flute taps for multi-purpose ISO metric coarse threads for blind holes
 Set de tarauds HSS-E avec filetage métrique pour filetage trou borgne

TiN Titanium Nitrid beschichtet
 Titannitrid coating
 Revêtue de nitrure de titane

10



Bestell Nr. Order no. Référence	Abmessung Size Dimension
TC.2060-S	(7tlg.) M3-M4-M5-M6-M8-M10-M12



HSS-E Gewindebohrer Satz Metrisches ISO-Gewinde für Durchgangsgewinde



Set of HSS-E spiral flute taps for multi-purpose ISO metric coarse threads for through holes
 Set de tarauds HSS-E avec filetage métrique pour filetage trou de passage



Bestell Nr.
Order no.
Référence

Abmessung
Size
Dimension

B.1500-S

(7tlg.) M3-M4-M5-M6-M8-M10-M12

TiN

Titanium Nitrid beschichtet
Titanitrid coating
Revêtue de nitrure de titane



10

Bestell Nr.
Order no.
Référence

Abmessung
Size
Dimension

TB.1510-S

(7tlg.) M3-M4-M5-M6-M8-M10-M12

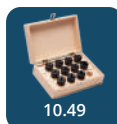

MASCHINENSCHRAUBSTÖCKE

MACHINE VICES

ÉTAUX POUR MACHINES

MASCHINENSCHRAUBSTÖCKE

MACHINE VICES

ÉTAUX POUR MACHINES

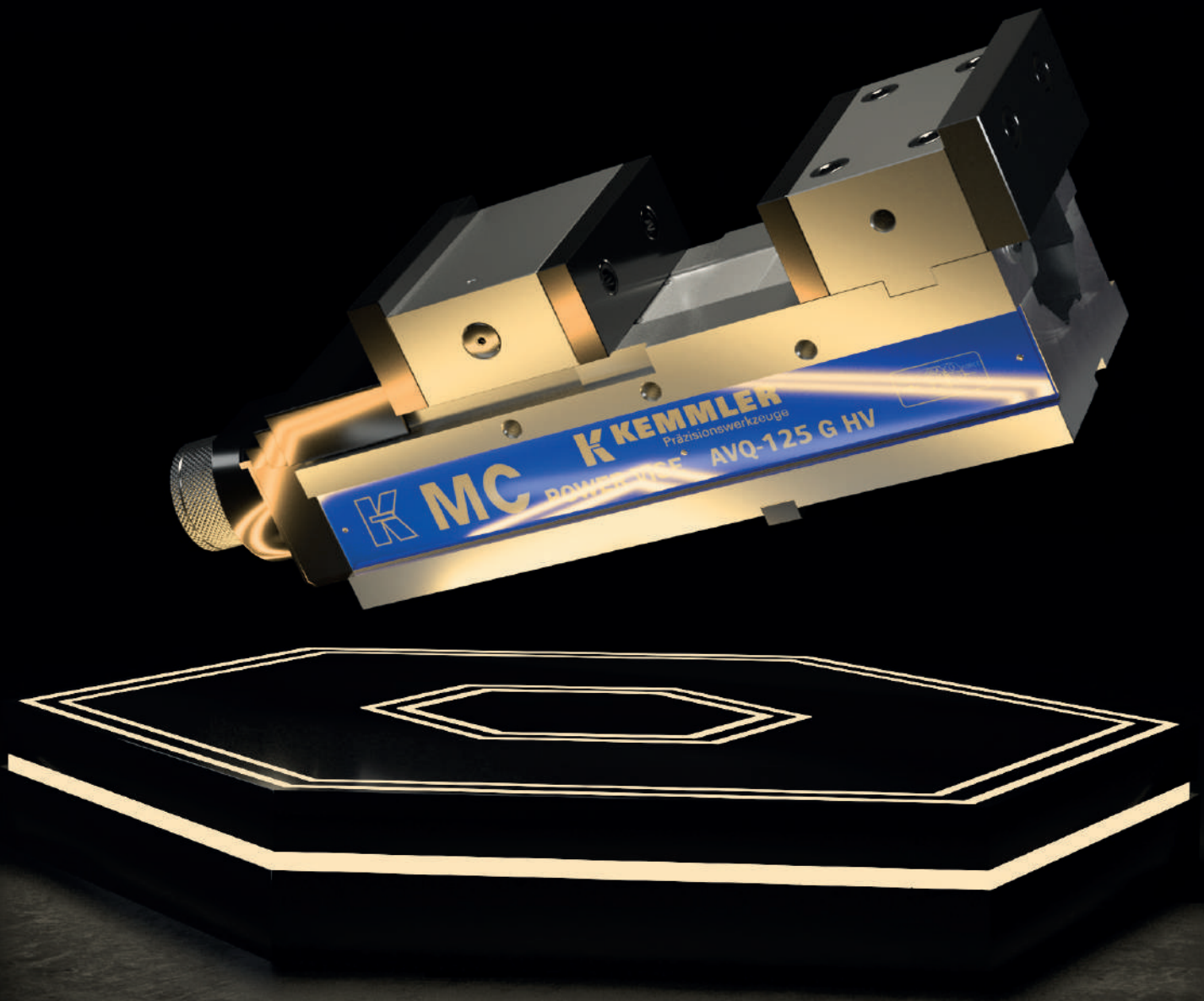



Präzisionsschraubstöcke

Precision vices Étaux de précision

- ❶ Einzigartiges Spannbacken-System zur Erhöhung der Spannkraft
- ❷ Das patentierte Anti-Lift-System garantiert eine problemlose Bearbeitung, ohne Anhub des Werkstückes
- ❸ Spannkraft mit Hilfe von Rillenmarkierungen voreinstellbar
- ❹ Durch den mechanischen Spannkraftverstärker kann auch während extremer Arbeiten am Werkstück eine konstant hohe Spannkraft von bis zu 6500 kg erzielt werden
- ❺ Alle Verschleißteile sind gehärtet und geschliffen

- ❶ *Unique clamping-jaw-system increases the clamping capacity*
- ❷ *The new Anti-Lift mechanism ensures that the workpiece does not lift during operations*
- ❸ *Clamping force preadjustable with the aid of graduation lines*
- ❹ *The mechanical Booster ensures that during extreme operations a constant high clamping-force up to 6500 kg can be reached*
- ❺ *All working parts are hardened and grinded*

- ❶ Système unique de serrage des mâchoires pour la force de serrage élevée
- ❷ Système patenté Anti-Lift garantit l'usinage sans problème, sans que la pièce à usiner ne soit soulevée
- ❸ Force de serrage à l'aide de repères à rainures, pré-réglable
- ❹ Grâce à l'amplificateur de force de serrage mécanique, il est aussi possible d'obtenir la force de serrage élevée et constante jusqu'à 6500 kg, lors de travaux extrêmes sur la pièce
- ❺ Toutes les pièces d'usure sont trempées et rectifiées

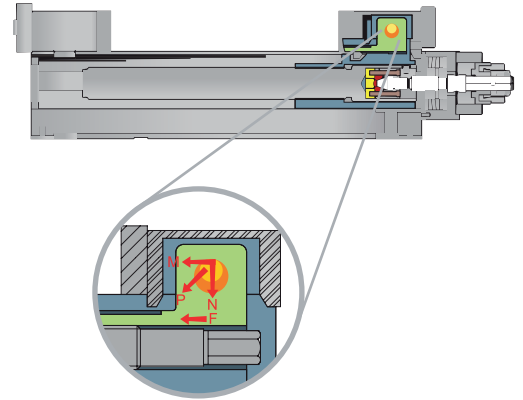

Durch das neue Anti-Lift-System werden die Werkstücke beim Spannen niedergezogen und präzise gespannt

By the new Anti-lift-system workpieces get pulled-down and precisely clamped

Grâce au nouveau système anti-levage, les pièces à usiner sont tirées vers le bas lors du serrage et serrées de manière précise

Allseitig gehärtet und geschliffen
All-round hardened and grinded
Complètement trempé et rectifié

Stabiler Späneschutz
Solid chip protector
Protection solide contre les copeaux

Spannkraft voreinstellbar
Clamping force preadjustable
Force de serrage pré-réglée

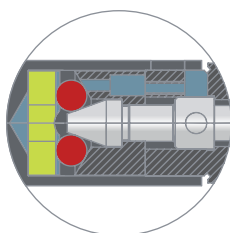
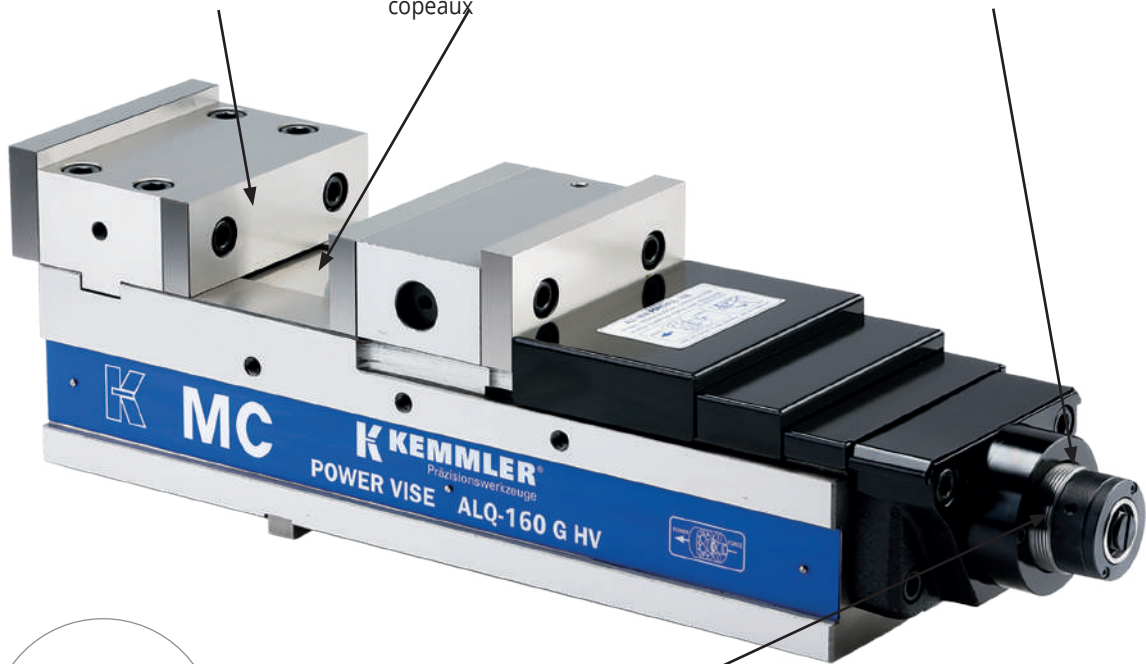

Mechanischer Spannkraftverstärker
Mechanical Booster
Amplificateur de la force de serrage mécanique

11.05	11.06	11.07	11.08
11.09	11.10	11.11	11.12
11.13	11.14	11.15	11.16
11.17	11.19	11.20	11.21
11.23	11.24	11.25	11.27
11.28	11.28	11.29	11.33
11.38	11.39	11.40	11.45
11.46 - 11.47	11.48		



Präzisionsschraubstöcke mechanisch mit Spannkraftverstärker

Precision vices mechanical with mechanical booster

Étaux de précision mécaniques avec l'amplificateur de la force de serrage

Ausführung:

- Mit mechanischem Spannkraftverstärker
- Spannkraft voreinstellbar durch Rillenmarkierung
- Horizontal, vertikal oder seitlich aufspannbar
- Stahlkörper allseitig geschliffen und gehärtet
- Eingebauter Niederzug
- Betthöhe H: $\leq 0,01$ mm

Lieferumfang:

- Bedienungsanleitung
- Incl. Spannschlüssel
- 4 Stück Spannpratzen
- 4 Stück T-Nutensteine 18mm
- Messprotokoll

Spannkraft:

KS01010 = 45 kN
KS01020 = 50 kN

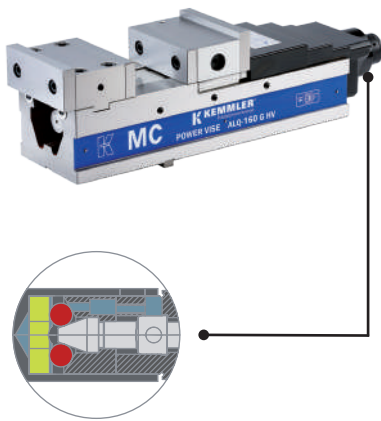

Construction:

- With mechanical booster
- Clamping force preadjustable by graduation lines
- Clamping positions: horizontal, vertical and lateral
- The steel body is hardened and grinded all-round
- Integrated pull-down mechanism
- Bed height H: $\leq 0,01$ mm

Delivery:

- Instructions for use
- Wrench
- 4 pcs. vice clamps
- 4 pcs. T-nuts 18mm
- Test certificate

Clamping force:

KS01010 = 45 kN
KS01020 = 50 kN

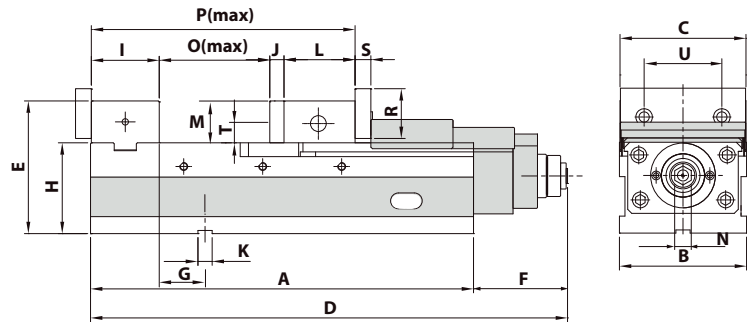
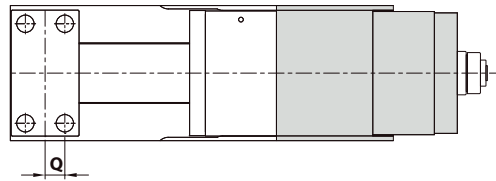

Version:

- Avec l'amplificateur de la force de serrage mécanique
- Force de serrage pré-réglable par le marquage des rainures
- Positions de serrage: horizontale, verticale ou latérale
- Corps en acier trempé et rectifié de tous côtés
- Mécanisme de traction vers le bas intégré
- Hauteur du socle H: $\leq 0,01$ mm

Livraison avec:

- Mode d'emploi
- Clé de serrage
- 4 Mors de serrage
- 4 Tasseaux pour rainures en T 18mm
- Protocole de mesure

Force de serrage:

KS01010 = 45 kN
KS01020 = 50 kN

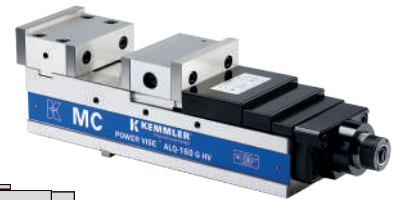

11

Mit patentiertem mechanischem Spannkraftverstärker:

- 1 kein Ölverlust
- 2 genaue Wiederholbarkeit der Spannkraft
- 3 keine Veränderung der Spannkraft
- 4 keine Vibrationen während der Bearbeitung
- 5 lange Lebensdauer

With patented mechanical booster:

- 1 no loss of oil
- 2 exact repeatability of the clamping force
- 3 constant clamping force
- 4 no vibrations during the operation
- 5 long life

Avec l'amplificateur de la force de serrage mécanique patenté:

- 1 pas de perte d'huile
- 2 la répétition précise de la force de serrage
- 3 pas de changement de la force de serrage
- 4 pas de vibrations pendant l'usinage
- 5 longue durée de vie

Bestell-Nr. Order no. Référence	Ausführung Version Version	A	B	C	D	E	F	G	H	I	J	K	L	M	N	O	P	Q	R	S	T	U	kN	kg
KS01010	ALQ-160G/HV	515	161	159,5	603	168	88	76	115	86	18	18	80	53	19	330,0	514,0	25	63	20	26,5	98,4	45	76
KS01020	ALQ-200G/HV	585	202	200,0	673	178	88	93	120	101	18	18	95	58	19	367,5	581,5	31	73	20	29	120	50	108

Precision vices mechanical with mechanical booster

Étaux de précision mécanique avec l'amplificateur de la force de serrage

Ausführung:

- Mit mechanischem Spannkraftverstärker
- Spannkraft voreinstellbar durch Rillenmarkierung
- Horizontal, vertikal oder seitlich aufspannbar
- Stahlkörper allseitig geschliffen und gehärtet
- Eingebauter Niederzug
- Betthöhe H: $\leq 0,01$ mm

Lieferumfang:

- Bedienungsanleitung
- Incl. Spannschlüssel
- 4 Stück Spannpratzen
- 4 Stück T-Nutensteine 18mm
- Messprotokoll

Spannkraft:

KS02010 = 25 kN
 KS02020 = 35 kN
 KS02030 = 45 kN
 KS02040 = 50 kN

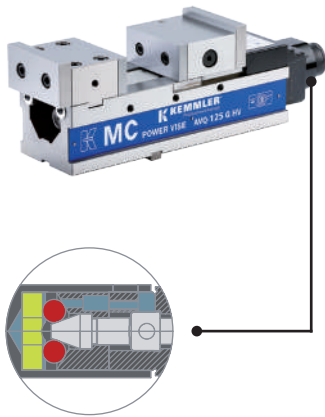

Construction:

- With mechanical booster
- Clamping force preadjustable by graduation lines
- Clamping positions: horizontal, vertical and lateral
- The steel body is hardened and grinded all-round
- Integrated pull-down mechanism
- Bed height H: $\leq 0,01$ mm

Delivery:

- Instructions for use
- Wrench
- 4 pcs. vice clamps
- 4 pcs. T-nuts 18mm
- Test certificate

Clamping force:

KS02010 = 25 kN
 KS02020 = 35 kN
 KS02030 = 45 kN
 KS02040 = 50 kN



Version:

- Avec l'amplificateur de la force de serrage mécanique
- Force de serrage pré-réglable par le marquage des rainures
- Positions de serrage: horizontale, verticale ou latérale
- Corps en acier trempé et rectifié de tous côtés
- Mécanisme de traction vers le bas intégré
- Hauteur du socle H: $\leq 0,01$ mm

Livraison avec:

- Mode d'emploi
- Clé de serrage
- 4 Mors de serrage
- 4 Tasseaux pour rainures en T 18mm
- Protocole de mesure

Force de serrage::

KS02010 = 25 kN
 KS02020 = 35 kN
 KS02030 = 45 kN
 KS02040 = 50 kN

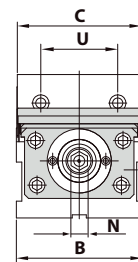
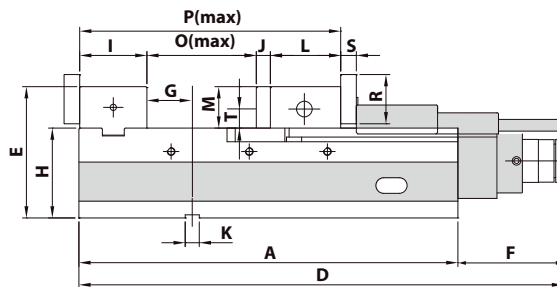
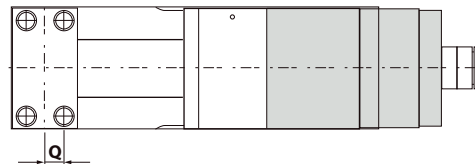

11.47



11.29



11.46

Mit patentiertem mechanischem Spannkraftverstärker:

- 1 kein Ölverlust
- 2 genaue Wiederholbarkeit der Spannkraft
- 3 keine Veränderung der Spannkraft
- 4 keine Vibrationen während der Bearbeitung
- 5 lange Lebensdauer

With patented mechanical booster:

- 1 no loss of oil
- 2 exact repeatability of the clamping force
- 3 constant clamping force
- 4 no vibrations during the operation
- 5 long life

Avec l'amplificateur de la force de serrage mécanique patenté:

- 1 pas de perte d'huile
- 2 a répétition précise de la force de serrage
- 3 pas de vibrations pendant l'usinage
- 4 pas de vibrations durant l'usinage
- 5 longue durée de vie

Bestell-Nr. Order no. Référence	Ausführung Version Version	A	B	C	D	E	F	G	H	I	J	K	L	M	N	O	P	Q	R	S	T	U	kN	kg
KS02010	AVQ-100G/HV	324	104	102	412	130	88	41	85	73	15	18	86,5	45	19	140	314,5	20	55	20	22,5	58	25	30
KS02020	AVQ-125G/HV	390	127	125	478	153	88	66	100	78	15	18	87,5	53	19	201	381,5	22,5	63	20	26,5	60	35	46
KS02030	AVQ-160G/HV	485	161	159,5	573	168	88	58	115	86	18	18	80	53	19	295	479	25	63	20	26,5	98,4	45	71
KS02040	AVQ-200G/HV	535	202	200	623	178	88	75	120	101	18	18	95	58	19	320	534	31	73	20	29	120	50	100



Präzisionsschraubstöcke mechanisch mit Spannkraftverstärker

Precision vices mechanical with mechanical booster

Étaux de précision mécanique avec l'amplificateur de la force de serrage

Ausführung:

- Mit mechanischem Spannkraftverstärker
- Spannkraft voreinstellbar durch Rillenmarkierung
- Horizontal und vertikal aufspannbar
- Stahlkörper allseitig geschliffen und gehärtet
- Eingebauter Niederzug
- Betthöhe H: $\leq 0,01$ mm

Lieferumfang:

- Bedienungsanleitung
- Incl. Spannschlüssel
- 4 Stück Spannpratzen
- 4 Stück T-Nutensteine 18mm
- Messprotokoll

Spannkraft:

KS14010 = 45 kN

Construction:

- With mechanical booster
- Clamping force preadjustable by graduation lines
- Clamping positions: horizontal and vertical
- The steel body is hardened and grinded all-round
- Integrated pull-down mechanism
- Bed height H: $\leq 0,01$ mm

Delivery:

- Instructions for use
- Wrench
- 4 pcs. vice clamps
- 4 pcs. T-nuts 18mm
- Test certificate

Clamping force:

KS14010 = 45 kN

Version:

- Avec l'amplificateur de la force de serrage mécanique
- Force de serrage pré-réglable par le marquage des rainures
- Positions de serrage: horizontale et verticale
- Corps en acier trempé et rectifié de tous côtés
- Mécanisme de traction vers le bas intégré
- Hauteur du socle H: $\leq 0,01$ mm

Livraison avec:

- Mode d'emploi
- Clé de serrage
- 4 Mors de serrage
- 4 Tasseaux pour rainures en T 18mm
- Protocole de mesure

Force de serrage:

KS14010 = 45 kN

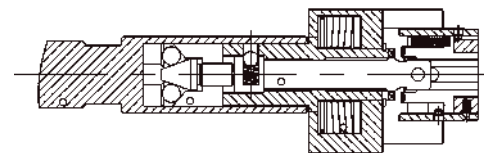
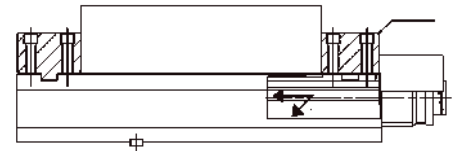
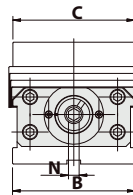
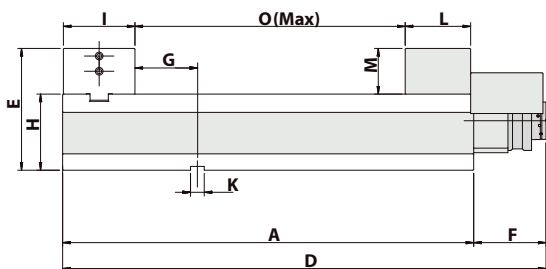
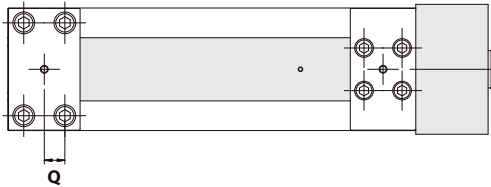
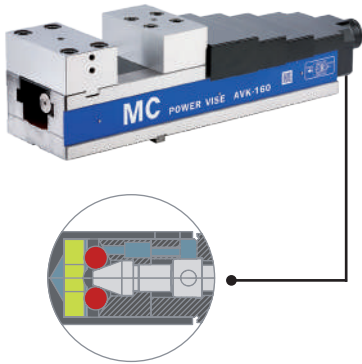

11

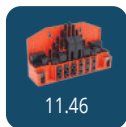

Bestell-Nr. Order no. Référence	Ausführung Version Version	A	B	C	D	E	F	G	H	I	K	M	N	O	Q	kN	kg
KS14010	AVK-160G/HV	540	161	160	628	160	88	82	100	94	18	60	14	355	27	45	65

Precision vices self-centering mechanical Étaux de précision auto-centrés mécaniques

Ausführung:

- Horizontal, vertikal oder seitlich aufspannbar
- Stahlkörper allseitig geschliffen und gehärtet
- Eingebauter Niederzug
- Betthöhe H: $\leq 0,01$ mm

Construction:

- *Clamping positions: horizontal, vertical and lateral*
- *The steel body is hardened and grinded all-round*
- *Integrated pull-down mechanism*
- *Bed height H: $\leq 0,01$ mm*

Version:

- Positions de serrage: horizontale, verticale ou latérale
- Corps en acier trempé et rectifié de tous côtés
- Mécanisme de traction vers le bas intégré
- Hauteur du socle H: $\leq 0,01$ mm

Lieferumfang:

- Bedienungsanleitung
- Incl. Spannschlüssel
- 4 Stück Spannpratzen
- 4 Stück T-Nutensteine 18mm
- Messprotokoll

Delivery:

- *Instructions for use*
- *Wrench*
- 4 pcs. vice clamps
- 4 pcs. T-nuts 18mm
- *Test certificate*

Livraison avec:

- Mode d'emploi
- Clé de serrage
- 4 Mors de serrage
- 4 Tasseaux pour rainures en T 18mm
- Protocole de mesure

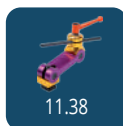
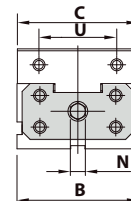
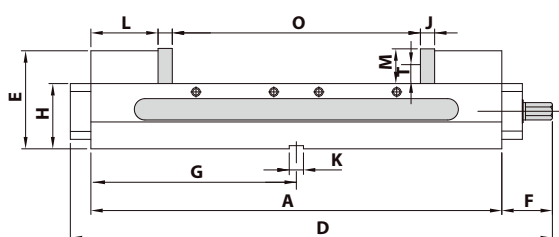
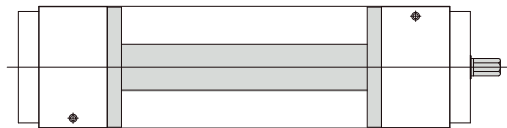
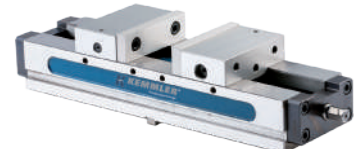

Bestell-Nr. Order no. Référence	Ausführung Version Version	A	B	C	D	E	F	G	H	J	K	L	M	N	O	T	U	kg
KS19010	HLD-60GG/HV	520	154	152	610	124,05	64	260	82,55	18	18	86,5	44,5	19	58-314	23,8	98,4	52



Präzisionsschraubstöcke mechanisch mit Spannkraftverstärker

Precision vices mechanical with mechanical booster

Étaux de précision mécanique avec l'amplificateur de la force de serrage

Ausführung:

- Mit mechanischem Spannkraftverstärker
- Spannkraft voreinstellbar durch Rillenmarkierung
- Horizontal, vertikal oder seitlich aufspannbar
- Stahlkörper allseitig geschliffen und gehärtet
- Eingebauter Niederzug
- Betthöhe H: $\leq 0,01$ mm

Lieferumfang:

- Bedienungsanleitung
- Incl. Spannschlüssel
- 4 Stück Spannpratzen
- 4 Stück T-Nutensteine 18mm
- Messprotokoll

Spannkraft:

KS15010 = 45 kN
KS15020 = 60 kN

Construction:

- With mechanical booster
- Clamping force preadjustable by graduation lines
- Clamping positions: horizontal, vertical and lateral
- The steel body is hardened and grinded all-round
- Integrated pull-down mechanism
- Bed height H: $\leq 0,01$ mm

Delivery:

- Instructions for use
- Wrench
- 4 pcs. vice clamps
- 4 pcs. T-nuts 18mm
- Test certificate

Clamping force:

KS15010 = 45 kN
KS15020 = 60 kN

Version:

- Avec l'amplificateur de la force de serrage mécanique
- Force de serrage pré-réglable par le marquage des rainures
- Positions de serrage: horizontale, verticale ou latérale
- Corps en acier trempé et rectifié de tous côtés
- Mécanisme de traction vers le bas intégré
- Hauteur du socle H: $\leq 0,01$ mm

Livraison avec:

- Mode d'emploi
- Clé de serrage
- 4 Mors de serrage
- 4 Tasseaux pour rainures en T 18mm
- Protocole de mesure

Force de serrage:

KS15010 = 45 kN
KS15020 = 60 kN

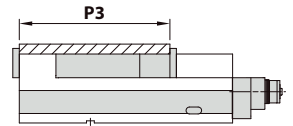
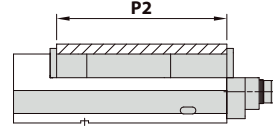
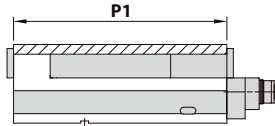
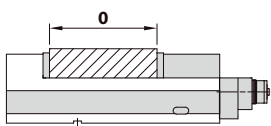
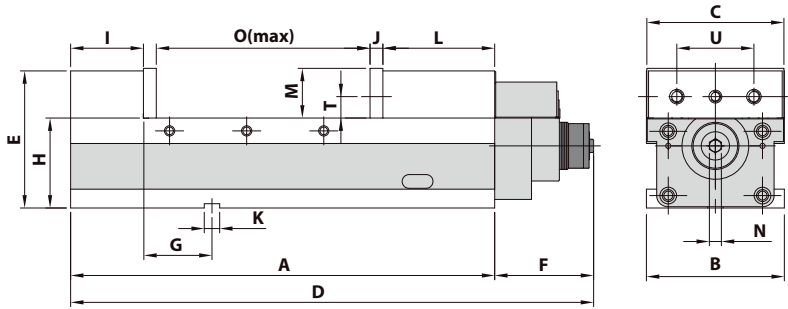
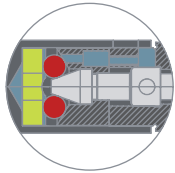
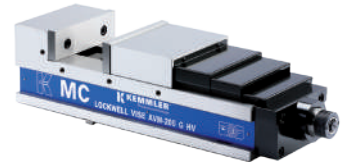
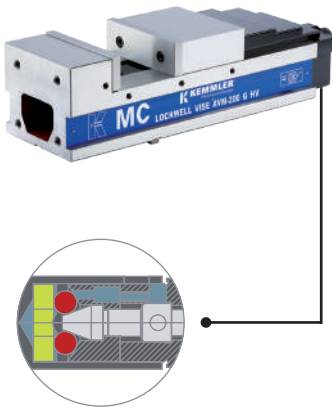

11

Bestell-Nr. Order no. Référence	Ausführung Version Version	A	B	C	D	E	F	G	H	I	J	K	L	M	N	O	P1	P2	P3	T	U	kN	kg
KS15010	AVM-160G/HV	495	161	160	583	160	88	80	105	85	15	18	130	58	19	245	250-480	250-370	250-330	25	90	43	55
KS15020	AVM-200G/HV	580	201	200	708	170	128	100	110	90	18	18	150	63	19	290	290-550	290-430	290-370	28	120	60	78

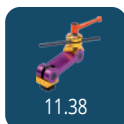

Precision vices mechanical Étaux de précision mécanique

Ausführung:

- Horizontal, vertikal oder seitlich aufspannbar
- Stahlkörper allseitig geschliffen und gehärtet
- Eingebauter Niederzug
- Betthöhe H: $\leq 0,01$ mm

Construction:

- *Clamping positions: horizontal, vertical and lateral*
- *The steel body is hardened and grinded all-round*
- *Integrated pull-down mechanism*
- *Bed height H: $\leq 0,01$ mm*

Version:

- Positions de serrage: horizontale, verticale ou latérale
- Corps en acier trempé et rectifié de tous côtés
- Mécanisme de traction vers le bas intégré
- Hauteur du socle H: $\leq 0,01$ mm

Lieferumfang:

- Bedienungsanleitung
- Incl. Spannschlüssel
- 4 Stück Spannpratzen
- 4 Stück T-Nutensteine 18mm
- Messprotokoll

Delivery:

- *Instructions for use*
- *Wrench*
- 4 pcs. vice clamps
- 4 pcs. T-nuts 18mm
- *Test certificate*

Livraison avec:

- Mode d'emploi
- Clé de serrage
- 4 Mors de serrage
- 4 Tasseaux pour rainures en T 18mm
- Protocole de mesure

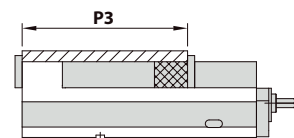
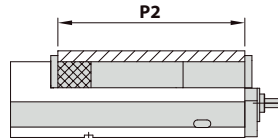
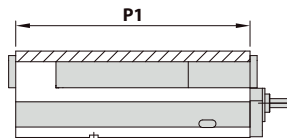
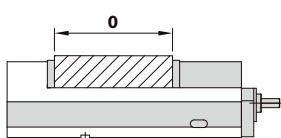
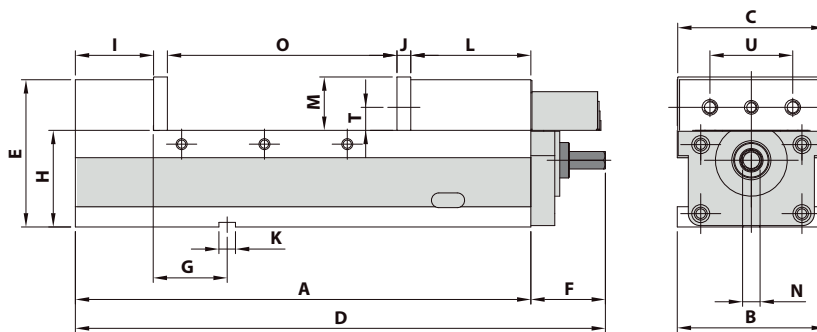
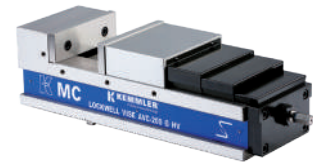

Bestell-Nr. Order no. Référence	Ausführung Version Version	A	B	C	D	E	F	G	H	I	J	K	L	M	N	O	P1	P2	P3	T	U	kg
KS16010	AVC-160G/HV	495	161	160	576	160	81	80	105	85	15	18	130	58	19	245	250-480	250-370	250-330	25	90	52
KS16020	AVC-200G/HV	580	201	200	670	170	90	85	110	90	18	18	130	63	19	250	290-550	290-430	290-370	28	120	75



K Präzisionsschraubstöcke mechanisch

Precision vices mechanical
Étaux de précision mécanique

Ausführung:

- Horizontal, vertikal oder seitlich aufspannbar
- Stahlkörper allseitig geschliffen und gehärtet
- Eingebauter Niederzug
- Betthöhe H: $\leq 0,01$ mm

Construction:

- Clamping positions: horizontal, vertical and lateral
- The steel body is hardened and grinded all-round
- Integrated pull-down mechanism
- Bed height H: $\leq 0,01$ mm

Version:

- Positions de serrage: horizontale, verticale ou latérale
- Corps en acier trempé et rectifié de tous côtés
- Mécanisme de traction vers le bas intégré
- Hauteur du socle H: $\leq 0,01$ mm

Lieferumfang:

- Bedienungsanleitung
- Incl. Spannschlüssel
- 4 Stück Spannpratzen
- 4 Stück T-Nutensteine 18mm
- Messprotokoll

Delivery:

- Instructions for use
- Wrench
- 4 pcs. vice clamps
- 4 pcs. T-nuts 18mm
- Test certificate

Livraison avec:

- Mode d'emploi
- Clé de serrage
- 4 Mors de serrage
- 4 Tasseaux pour rainures en T 18mm
- Protocole de mesure

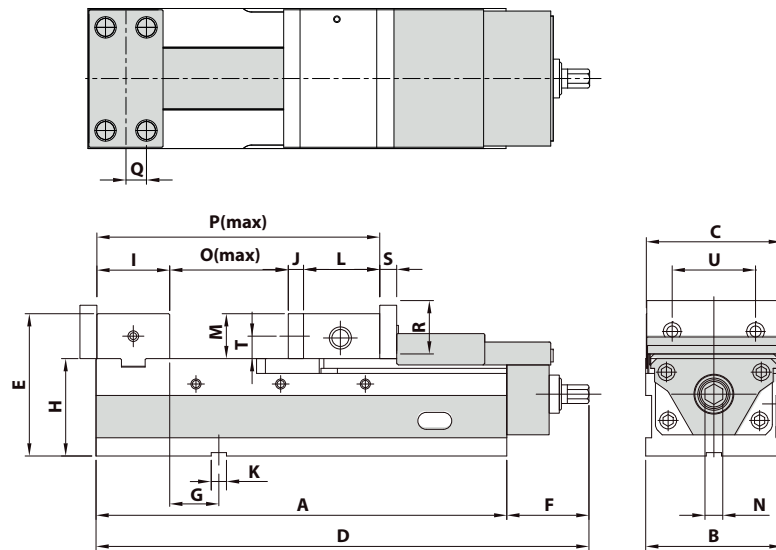

11

Bestell-Nr. Order no. Référence	Ausführung Version Version	A	B	C	D	E	F	G	H	I	J	K	L	M	N	O	P	Q	R	S	T	U	kg
KS05010	AVL-100G/HV	324	104	102,0	437	130	104	41	85	73	15	18	86,5	45	19	140	314,5	20,0	55	17	22,5	58	27
KS05020	AVL-125G/HV	390	127	125,0	480	153	105	66	100	78	15	18	87,5	53	19	201	381,5	22,5	63	20	26,5	60	43
KS05030	AVL-160G/HV	485	161	159,5	625	168	120	76	115	86	18	18	80,0	53	21	295	479,0	25,0	63	20	26,5	98,4	71
KS05040	AVL-200G/HV	535	202	199,5	660	178	128	93	120	101	18	18	95,0	58	19	320	534,0	31,0	73	20	29,0	120	98

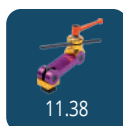

Precision vices pneumatic hydraulic
Étaux de précision pneumatiques hydrauliques

Ausführung:

- Geeignet für Serienfertigung
- Horizontal und vertikal aufspannbar
- Stahlkörper allseitig geschliffen und gehärtet
- Betthöhe H: ≤ 0,01 mm

Construction:

- Suitable for mass production
- Clamping positions: horizontal and vertical
- The steel body is hardened and grinded all-round
- Bed height H: ≤ 0,01 mm

Version:

- Convient pour la production en série
- Positions de serrage: horizontale, ou verticale
- Corps en acier trempé et rectifié de tous côtés
- Hauteur du socle H: ≤ 0,01 mm

Lieferumfang:

- Bedienungsanleitung
- Incl. Spannschlüssel
- 4 Stück Spannpratzen
- 4 Stück T-Nutensteine 18mm
- Messprotokoll

Delivery:

- Instructions for use
- Wrench
- 4 pcs. vice clamps
- 4 pcs. T-nuts 18mm
- Test certificate

Livraison avec:

- Mode d'emploi
- Clé de serrage
- 4 Mors de serrage
- 4 Tasseaux pour rainures en T 18mm
- Protocole de mesure

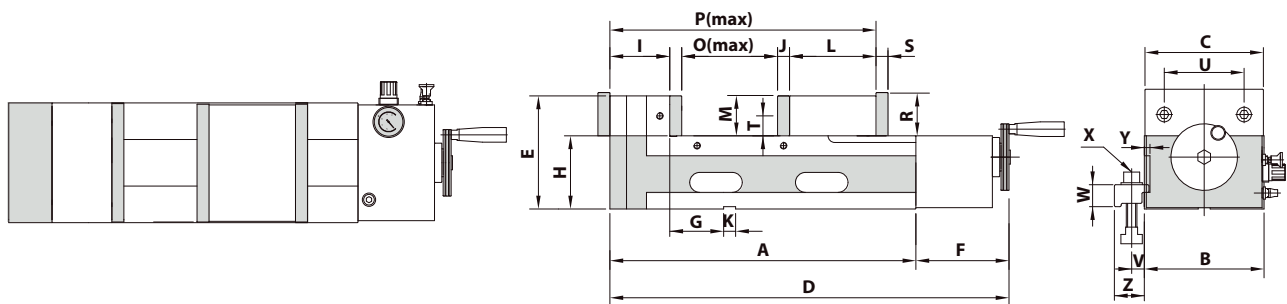

Bestell-Nr. Order no. Référence	Ausführung Version	A	B	C	D	E	F	G	H	I	J	K	L	M	N	O	P	R	S	T	U	V	W	X	Y	Z	kN	kg
KS18150	AMP-150G/HV	380	130	128	505	157	125	45	105	85	15	18	110	52	-	150	200-380	62	20	25	90	17,5	33	M16x65L	8,5	43,5	62	52
KS18160	AMP-160G/HV	400	160	158	525	160	125	45	105	87	15	18	120	55	-	160	210-400	62	20	25	90	16,5	33	M16x65L	9,5	42,5	62	58
KS18165	AMP-165G/HV	490	160	158	615	160	125	45	105	87	15	18	120	55	-	250	210-490	65	20	25	90	16,5	33	M16x65L	9,5	42,5	62	65
KS18180	AMP-180G/HV	460	180	178	585	170	125	72	110	90	18	18	130	60	-	200	220-460	70	20	28	120	15,5	33	M16x65L	12,5	39,5	90	75
KS18200	AMP-200G/HV	470	200	200	595	170	125	72	110	90	18	18	140	60	-	200	230-470	70	20	28	120	15,5	33	M16x65L	12,5	39,5	90	82
KS18300	AMP-300G/HV	570	200	200	695	170	125	72	110	90	18	18	140	60	-	300	230-570	70	20	28	120	15,5	33	M16x65L	12,5	39,5	90	93

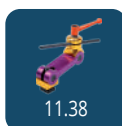

K Doppelspannstöcke mechanisch

Twin vices mechanical Étaux mécaniques doubles

Ausführung:

- Doppelspannung mit 2 beweglichen und einer festen Spannbacke
- Horizontal und vertikal aufspannbar
- Stahlkörper allseitig geschliffen und gehärtet
- Eingebauter Niederzug
- Spannwiederholgenauigkeit $\leq 0,01$ mm
- Mittenspanngenauigkeit $\leq 0,01$ mm
- Betthöhe H: $\leq 0,01$ mm

Lieferumfang:

- Bedienungsanleitung
- Incl. Spannschlüssel
- 4 Stück Spannpratzen
- 4 Stück T-Nutensteine 18mm
- Messprotokoll

Construction:

- Double-clamping via two mobile and one fixed jaw.
- Clamping positions: horizontal, and vertical
- The steel body is hardened and grinded all-round
- Integrated pull-down mechanism
- Repeating accuracy $\leq 0,01$ mm
- Clamping accuracy at the centre $\leq 0,01$ mm
- Bed height H: $\leq 0,01$ mm

Delivery:

- Instructions for use
- Wrench
- 4 pcs. vice clamps
- 4 pcs. T-nuts 18mm
- Test certificate

Version:

- Double serrage avec 2 mors mobiles et un mors fixe
- Positions de serrage: horizontale, ou verticale
- Corps en acier trempé et rectifié de tous côtés
- Mécanisme de traction vers le bas intégré
- Répétition du serrage $\leq 0,01$ mm
- Précision de serrage du centre $\leq 0,01$ mm
- Hauteur du socle H: $\leq 0,01$ mm

Livraison avec:

- Mode d'emploi
- Clé de serrage
- 4 Mors de serrage
- 4 Tasseaux pour rainures en T 18mm
- Protocole de mesure

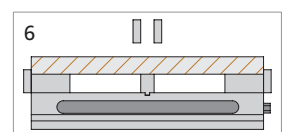
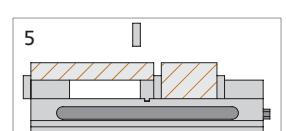
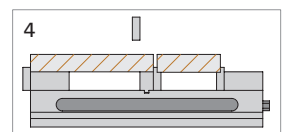
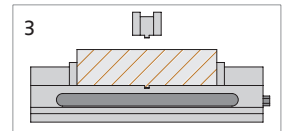
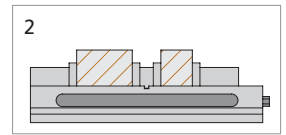
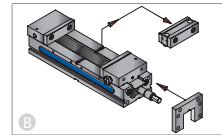
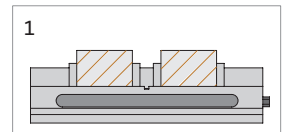
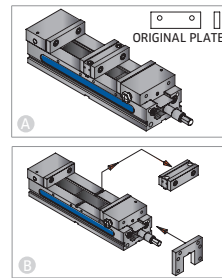
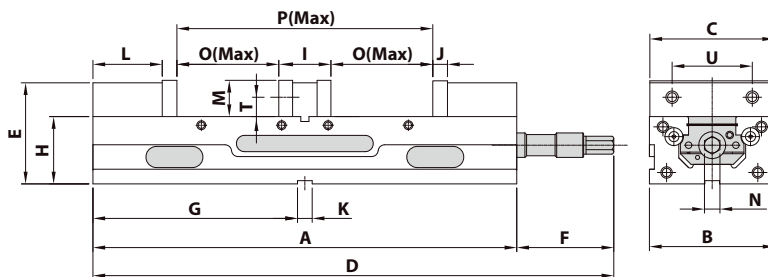
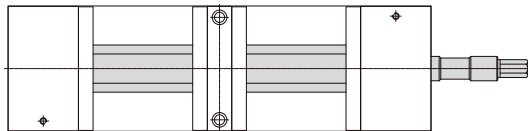

11.47



11.29

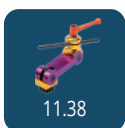

11.38



11.46

Bestell-Nr. Order no. Référence	Ausführung Version Version	A	B	C	D	E	F	G	H	I	J	K	L	M	N	O	P	T	U	kg
KS09010	TLD-40G/HV	405	104	102	459	96,5	54	27,5	63,50	55	15	18	69	38	14	90	235	17,5	63,5	20
KS09020	TLD-60G/HV	520	154	152	536	124,05	16	33,0	82,55	66	18	18	86,5	44,5	19	125	316	316	98,4	52

Twin vices mechanical Étaux mécaniques doubles

Ausführung:

- Doppelspannung mit 2 beweglichen und einer festen Spannbacke
- Horizontal und vertikal aufspannbar
- Stahlkörper allseitig geschliffen und gehärtet
- Eingebauter Niederzug
- Spannweitenholgenauigkeit $\leq 0,01$ mm
- Mittenspanngenauigkeit $\leq 0,01$ mm
- Betthöhe H: $\leq 0,01$ mm

Construction:

- Double-clamping via two mobile and one fixed jaw
- Clamping positions: horizontal and vertical
- The steel body is hardened and grinded all-round
- Integrated pull-down mechanism
- Repeating accuracy $\leq 0,01$ mm
- Clamping accuracy at the centre $\leq 0,01$ mm
- Bed height H: $\leq 0,01$ mm

Version:

- Double serrage avec 2 mors mobiles et un mors fixe
- Positions de serrage: horizontale, ou verticale
- Corps en acier trempé et rectifié de tous côtés
- Mécanisme de traction vers le bas intégré
- Répétition du serrage $\leq 0,01$ mm
- Précision de serrage du centre $\leq 0,01$ mm
- Hauteur du socle H: $\leq 0,01$ mm

Lieferumfang:

- Bedienungsanleitung
- Incl. Spannschlüssel
- 4 Stück Spannpratzen
- 4 Stück T-Nutensteine 18mm
- Messprotokoll

Delivery:

- Instructions for use
- Wrench
- 4 pcs. vice clamps
- 4 pcs. T-nuts 18mm
- Test certificate

Livraison avec:

- Mode d'emploi
- Clé de serrage
- 4 Mors de serrage
- 4 Tasseaux pour rainures en T 18mm
- Protocole de mesure

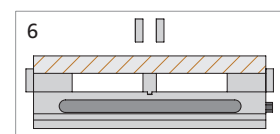
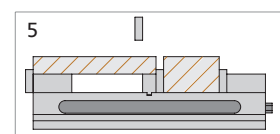
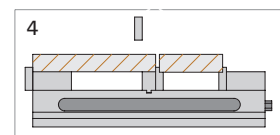
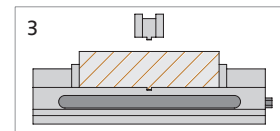
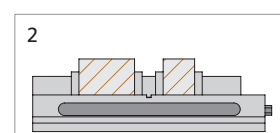
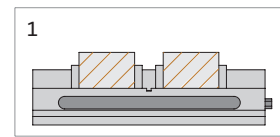
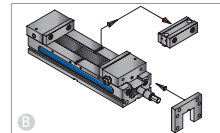
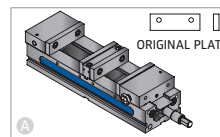
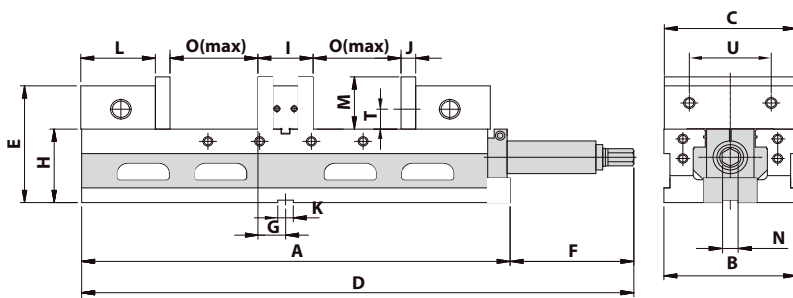
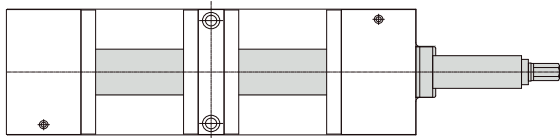
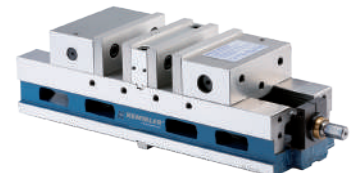
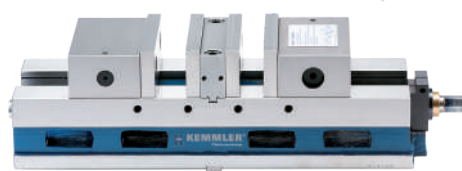
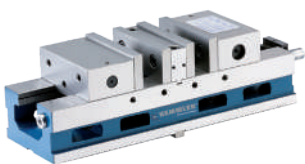

11.47



11.29

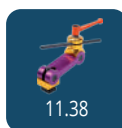

11.38

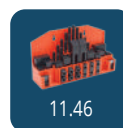

11.46

Bestell-Nr. Order no. Référence	Ausführung Version Version	A	B	C	D	E	F	G	H	I	J	K	L	M	N	O	T	U	kg
KS10010	ALD-60G/HV	497	154	152	610	143	113	32	90	64	17	18	86,5	58	19	34-102	32	95	63,5

K 5-Achs Maschinen-Schraubstöcke

5-Axis-Machine vices Étaux à 5-axes

Ausführung:

- Horizontal, vertikal oder seitlich aufspannbar
- Stahlkörper allseitig geschliffen und gehärtet
- Eingebauter Niederzug
- Betthöhe H: $\leq 0,01$ mm

Construction:

- *Clamping positions: horizontal, vertical and lateral*
- *The steel body is hardened and grinded all-round*
- *Integrated pull-down mechanism*
- *Bed height H: $\leq 0,01$ mm*

Version:

- Positions de serrage: horizontale, verticale ou latérale
- Corps en acier trempé et rectifié de tous côtés
- Mécanisme de traction vers le bas intégré
- Hauteur du socle H: $\leq 0,01$ mm

Lieferumfang:

- Bedienungsanleitung
- Incl. Spannschlüssel
- 4 Stück Spannpratzen
- 4 Stück T-Nutensteine 18mm
- Messprotokoll

Delivery:

- *Instructions for use*
- *Wrench*
- 4 pcs. vice clamps
- 4 pcs. T-nuts 18mm
- *Test certificate*

Livraison avec:

- Mode d'emploi
- Clé de serrage
- 4 Mors de serrage
- 4 Tasseaux pour rainures en T 18mm
- Protocole de mesure

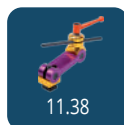
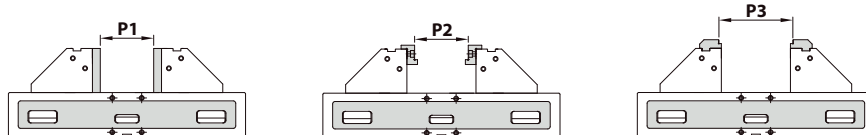
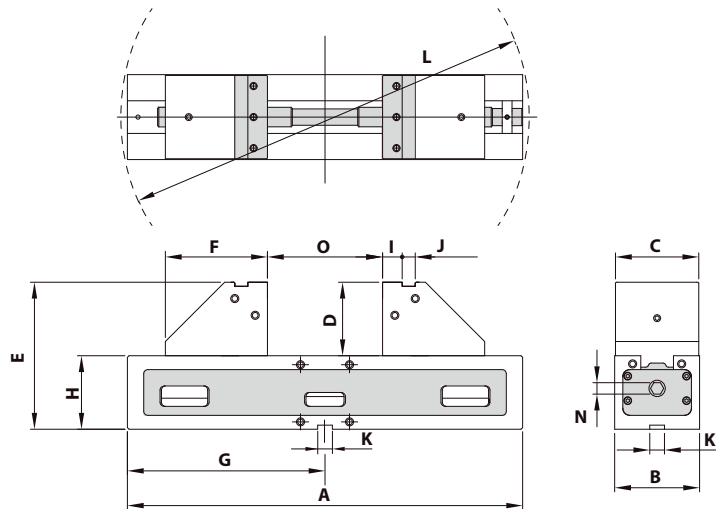

Bestell-Nr. Order no. Référence	Ausführung Version Version	A	B	C	D	E	F	G	H	I	J	K	L	N	O	P1	P2	P3	KN	kg
KS20100	ALT-100M	324	104	102	90	180	125	162	90	24	16	18	350	14	0-74	0-44	12-44	10-84	20	20
KS20101	ALT-100L	484	104	102	90	180	125	242	90	24	16	18	500	14	10-232	0-200	12-200	10-210	20	30

mechanisch mit Spannkraftverstärker

5-Axis precision vice AEX 125G mechanical with mechanical booster

Étau de précision à 5 axes AEX 125G mécanique avec l'amplificateur de serrage

Ausführung:

- Mit mechanischem Spannkraftverstärker
- Spannkraft voreinstellbar durch Rillenmarkierung
- Eingebauter Niederzug
- Betthöhe H: ≤ 0,01 mm

Lieferumfang:

- Bedienungsanleitung
- Incl. Spannschlüssel
- 4 Stück Spannpratzen
- 4 Stück T-Nutensteine 14mm
- Messprotokoll

Spannkraft:

KS20200 = 40 kN

Construction:

- With mechanical booster
- Clamping force preadjustable by graduation lines
- Integrated pull-down mechanism
- Bed height H: ≤ 0,01 mm

Delivery:

- Instructions for use
- Wrench
- 4 pcs. vice clamps
- 4 pcs. T-nuts 14mm
- Test certificate

Clamping force:

KS20200 = 40 kN

Version:

- Avec l'amplificateur de serrage mécanique
- Force de serrage pré-réglable par le marquage des rainures
- Mécanisme de traction vers le bas intégré
- Hauteur du socle H: ≤ 0,01 mm

Livraison avec:

- Mode d'emploi
- Clé de serrage
- 4 Mors de serrage
- 4 Tasseaux pour rainures en T 14mm
- Protocole de mesure

Force de serrage:

KS20200 = 40 kN

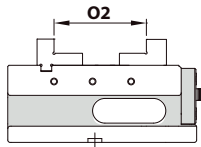
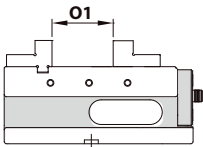
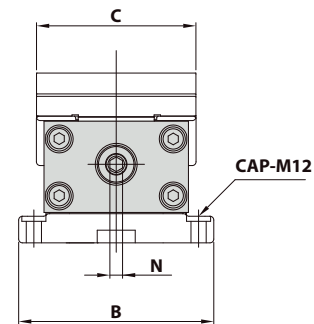
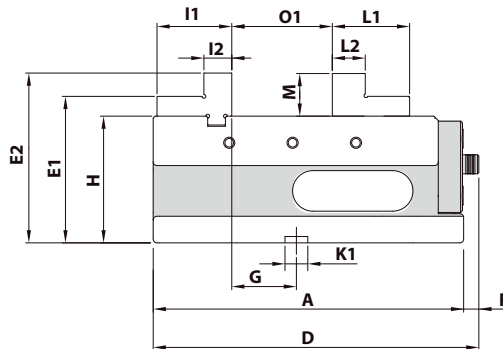
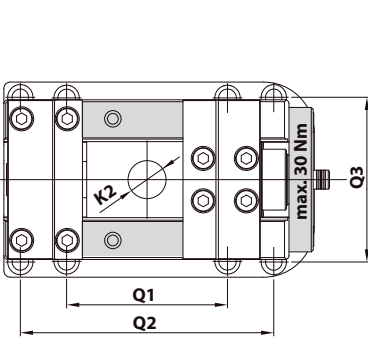

Lieferung mit Krallenbacken
Delivery with claw jaws
Livré avec mors à griffes

Bestell-Nr. Order no. Référence	Ausführung Version Version	A	B	C	D	E	E1	E2	F	G	H	I1	I2	K1	K2	L1	L2	M	N	O1	O2	Q1	Q2	Q3	kN	kg
KS20200	AEX 125G	245	154	126	257	34	116	134	12	51	100	59	22	18	∅30	61	26	34	10	100	72-139	127	200	130	40	20

K Mehrfachspannsystem 3-teilig

Multiple Clamping System 3-parts
Système de serrage multiple 3 pièces

Ausführung:

- Mit mechanischem Spannkraftverstärker
- Spannkraft voreinstellbar durch Rillenmarkierung
- Stahlkörper allseitig geschliffen und gehärtet
- Eingebauter Niederzug
- Betthöhe H: $\leq 0,01$ mm

Lieferumfang:

- Bedienungsanleitung
- Incl. Spannschlüssel
- 4 Stück Spannpratzen
- 4 Stück T-Nutensteine 18mm
- Messprotokoll

Spannkraft:

KS22020 = 50 kN

Construction:

- With mechanical booster
- Clamping force preadjustable by graduation lines
- The steel body is hardened and grinded all-round
- Integrated pull-down mechanism
- Bed height H: $\leq 0,01$ mm

Delivery:

- Instructions for use
- Wrench
- 4 pcs. vice clamps
- 4 pcs. T-nuts 18mm
- Test certificate

Clamping force:

KS22020 = 50 kN

Version:

- Avec l'amplificateur de serrage mécanique
- Force de serrage pré-réglable par le marquage des rainures
- Corps en acier trempé et rectifié de tous côtés
- Mécanisme de traction vers le bas intégré
- Hauteur du socle H: $\leq 0,01$ mm

Livraison avec:

- Mode d'emploi
- Clé de serrage
- 4 Mors de serrage
- 4 Tasseaux pour rainures en T 18mm
- Protocole de mesure

Force de serrage:

KS22020 = 50 kN

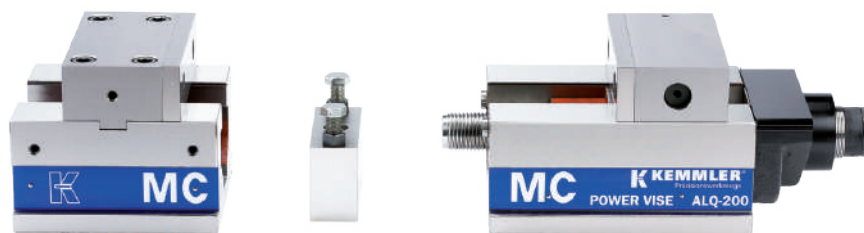
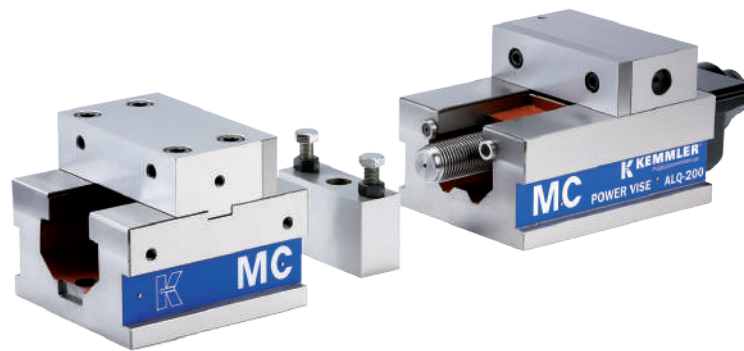

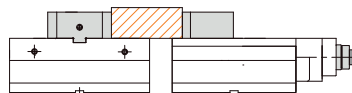
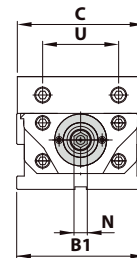
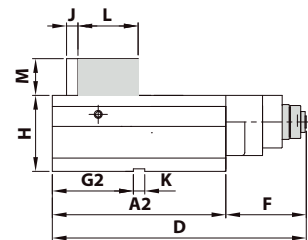
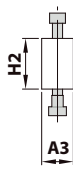
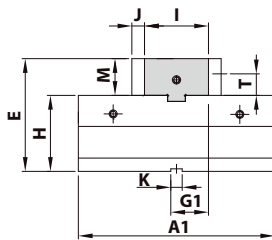
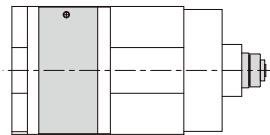
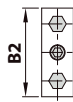
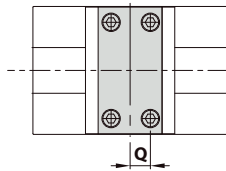
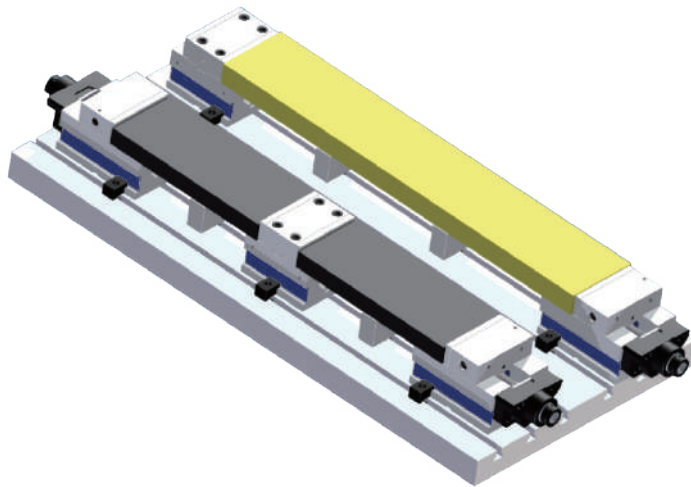
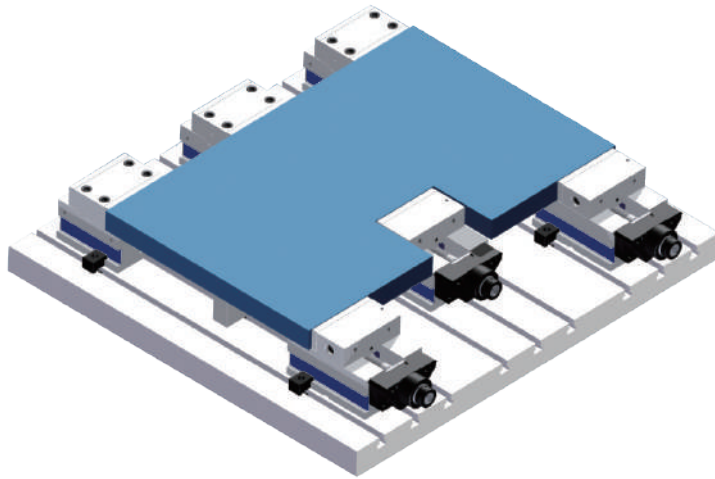

Bestell-Nr. Order no. Référence	Ausführung Version	A1	A2	A3	B1	B2	C	D	E	F	G1	G2	H	I	J	K	L	M	N	Q	T	U	KN	kg
KS22020	AOM-200/HV	210	270	50	202	140	199,5	398	178	128	59,5	126	120	101	18	18	95	58	19	31	29	120	50	95

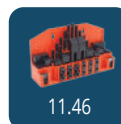
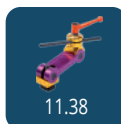

K Präzisionsschraubstöcke mechanisch

Precision vices mechanical Étaux de précision mécanique

Ausführung:

- Horizontal, vertikal oder seitlich aufspannbar
- Stahlkörper allseitig geschliffen und gehärtet
- Eingebauter Niederzug
- Betthöhe H: $\leq 0,01$ mm

Construction:

- *Clamping positions: horizontal, vertical and lateral*
- *The steel body is hardened and grinded all-round*
- *Integrated pull-down mechanism*
- *Bed height H: $\leq 0,01$ mm*

Version:

- Positions de serrage: horizontale, verticale ou latérale
- Corps en acier trempé et rectifié de tous côtés
- Mécanisme de traction vers le bas intégré
- Hauteur du socle H: $\leq 0,01$ mm

Lieferumfang:

- Bedienungsanleitung
- Incl. Spannschlüssel
- 4 Stück Spannpratzen
- 4 Stück T-Nutensteine 18mm
- Messprotokoll

Delivery:

- *Instructions for use*
- *Wrench*
- 4 pcs. vice clamps
- 4 pcs. T-nuts 18mm
- *Test certificate*

Livraison avec:

- Mode d'emploi
- Clé de serrage
- 4 Mors de serrage
- 4 Tasseaux pour rainures en T 18mm
- Protocole de mesure

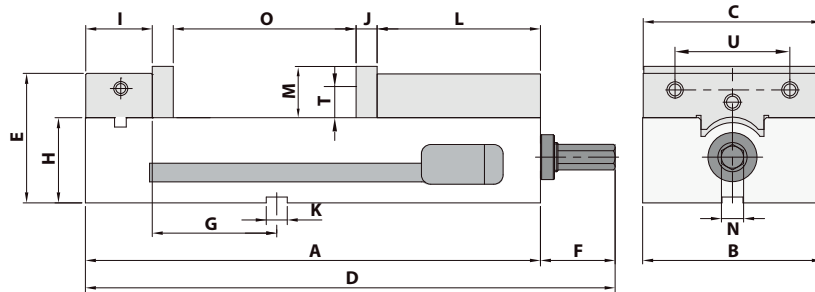

11

Bestell-Nr. Order no. Référence	Ausführung Version Version	A	B	C	D	E	F	G	H	I	J	K	L	M	N	O	T	U	kg
KS12010	AMC-40G/HV	330	105	102	372	100	42	91,6	68	46,8	21	18	106	40,0	14	125	17,5	63,5	21,0
KS12020	AMC-60G/HV	390	154	151	455	111	65	106,7	73	57,0	18	18	140	44,5	19	148	23,8	98,4	36,5

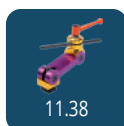

Precision vices mechanical Étaux de précision mécanique

Ausführung:

- Horizontal und vertikal aufspannbar
- Stahlkörper geschliffen und gehärtet
- Eingebauter Niederzug
- Betthöhe H: $\leq 0,01$ mm

Construction:

- *Clamping positions: horizontal and vertical*
- *The steel body is hardened and grinded*
- *Integrated pull-down mechanism*
- *Bed height H: $\leq 0,01$ mm*

Version:

- Positions de serrage: horizontale ou verticale
- Corps en acier trempé et rectifié de tous côtés
- Mécanisme de traction vers le bas intégré
- Hauteur du socle H: $\leq 0,01$ mm

Lieferumfang:

- Bedienungsanleitung
- Incl. Spannschlüssel
- Messprotokoll

Delivery:

- *Instructions for use*
- *Wrench*
- *Test certificate*

Livraison avec:

- Mode d'emploi
- Clé de serrage
- Protocole de mesure

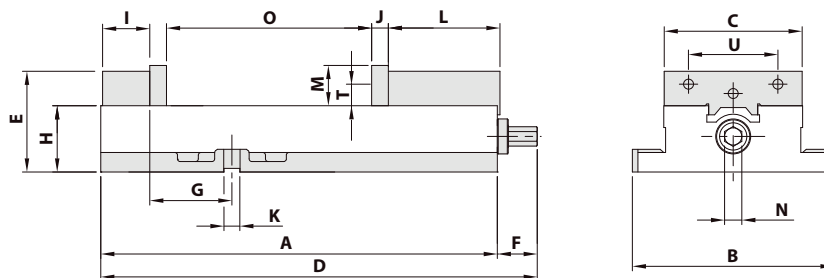
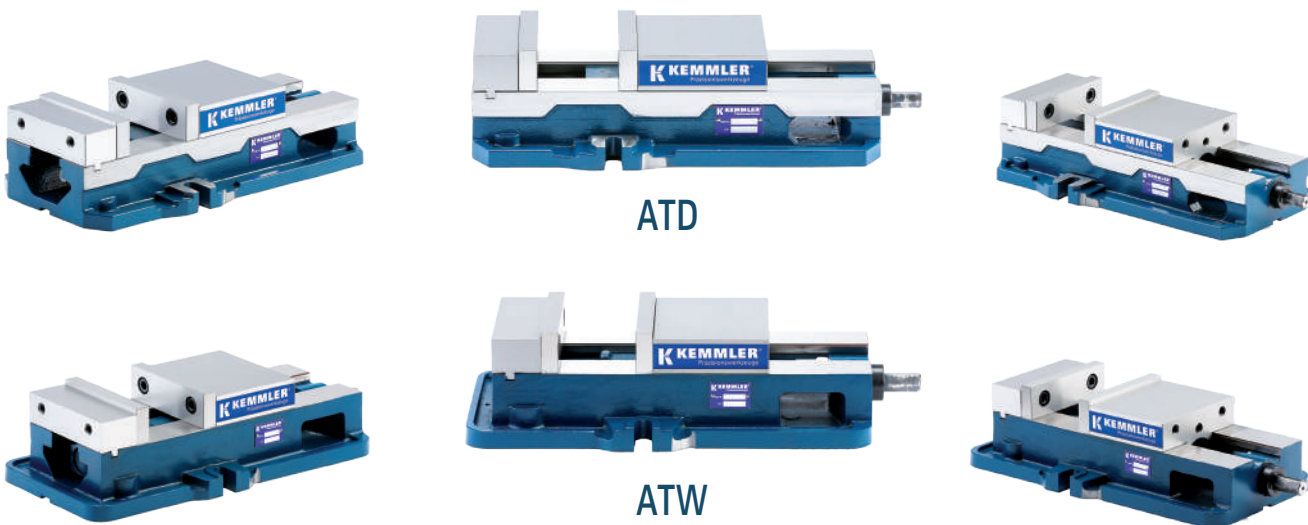

Bestell-Nr. Order no. Référence	Ausführung Version Version	A	B	C	D	E	F	G	H	I	J	K	L	M	N	O	T	U	kg
KS11010	ATD-460	312,5	166	102	361	85,65	40	71	57,15	35,1	15	12	102	35,0	14	153	17,5	63,5	18
KS11020	ATD-570	368	194	127,0	404	97,00	36	85	63,5	40,5	17	16	120	38,1	16	178	20,6	79,4	25
KS11030	ATW-675	432	235	151	476	111,025	44	108	73,02	52	18	18	123	44,5	19	192	23,8	98,4	36
KS11040	ATW-689	437	222	151	481	111,025	44	90,5	73,025	52	18	18	123	44,5	19	226	23,8	98,4	36
KS11050	ATW-810	555	295	206	615	134,074	60	125,7	84,074	58	24,2	18	157	56,0	19	265	32,0	120	68



K Präzisionsschraubstöcke mechanisch

Precision vices mechanical Étaux de précision mécanique

Ausführung:

- Horizontal, vertikal oder seitlich aufspannbar
- Stahlkörper allseitig geschliffen und gehärtet
- Eingebauter Niederzug
- Betthöhe H: $\leq 0,01$ mm

Construction:

- *Clamping positions: horizontal, vertical and lateral*
- *The steel body is hardened and grinded all-round*
- *Integrated pull-down mechanism*
- *Bed height H: $\leq 0,01$ mm*

Version:

- Positions de serrage: horizontale, verticale ou latérale
- Corps en acier trempé et rectifié de tous côtés
- Mécanisme de traction vers le bas intégré
- Hauteur du socle H: $\leq 0,01$ mm

Lieferumfang:

- Bedienungsanleitung
- Incl. Spannschlüssel
- 4 Stück Spannpratzen
- 4 Stück T-Nutensteine 18mm
- Messprotokoll

Delivery:

- *Instructions for use*
- *Wrench*
- 4 pcs. vice clamps
- 4 pcs. T-nuts 18mm
- *Test certificate*

Livraison avec:

- Mode d'emploi
- Clé de serrage
- 4 Mors de serrage
- 4 Tasseaux pour rainures en T 18mm
- Protocole de mesure

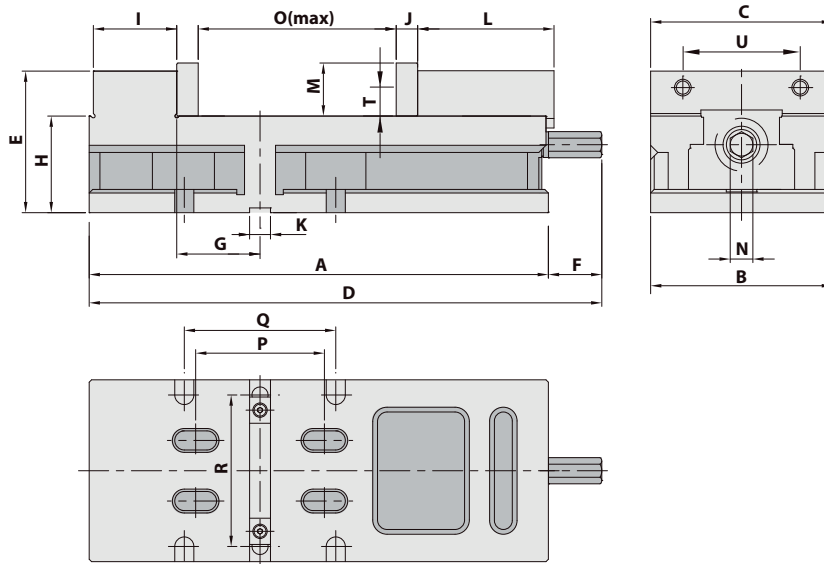

11

Bestell-Nr. Order no. Référence	Ausführung Version Version	A	B	C	D	E	F	G	H	I	J	K	L	M	N	O	P	Q	R	T	U	kg
KS13010	MG-60G	385	152,45	151	431,8	118,7	46,8	69,85	81	69,9	18	18	114,3	44,5	19	163	107,95	127	127	23,8	98,4	31

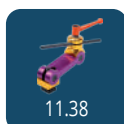



Technische Datenblätter, STEP/STL Modelle für die Simulation der NC-Programme und DXF-Zeichnungen zur Erstellung des Einrichteblattes stehen Online zur Verfügung.

Technical data sheets, STEP/STL models for the simulation of NC programs and DXF drawings to create the tooling sheet are online available.

Fiches techniques, STEP/STL modèles techniques pour la simulation de programmes CN et dessins DXF pour créer la feuille d'installation sont disponible online.

Sie können unsere Kataloge entweder direkt im Browser betrachten oder sie auf Ihren PC, Smartphone oder Tablet herunterladen (PDF-Reader notwendig).

You can view our catalogues either directly in the browser or download to your PC, smartphone or tablet (PDF reader required).

Vous pouvez consulter nos catalogues directement dans le navigateur ou télécharger sur votre PC, smartphone ou tablet (lecteur PDF requis).

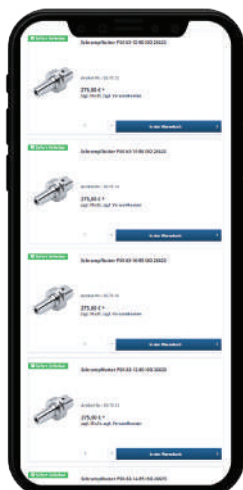

Auf unserer Internetseite können Sie die Lagerverfügbarkeit prüfen - auch auf Mobilgeräten.

On our website you can check the stock availability - also on mobile devices.

Vous pouvez également vérifier la disponibilité de nos produits sur le site Internet - ainsi que sur vos appareils



Präzisionsschraubstöcke mechanisch mit Spannkraftverstärker

Precision vices mechanical with mechanical booster
Étaux de précision mécanique avec répéteur de la tension du ressort

Ausführung:

- Mit mechanischem Spannkraftverstärker
- Spannkraft voreinstellbar durch Rillenmarkierung
- Horizontal und vertikal aufspannbar
- Führungen geschliffen und gehärtet
- Betthöhe H: ≤ 0,01 mm

Lieferumfang:

- Bedienungsanleitung
- Incl. Spannschlüssel
- Messprotokoll

Spannkraft:

KS06010 = 40 kN
KS06020 = 50 kN
KS06030 = 60 kN

Construction:

- With mechanical booster
- Clamping force preadjustable by graduation lines
- Clamping positions: horizontal and vertical
- Slides hardened and grinded
- Bed height H: ≤ 0,01 mm

Delivery:

- Instructions for use
- Wrench
- Test certificate

Clamping force:

KS06010 = 40 kN
KS06020 = 50 kN
KS06030 = 60 kN

Version:

- Avec l'amplificateur de serrage mécanique
- Force de serrage pré-réglable par le marquage des rainures
- Positions de serrage: horizontale ou verticale
- Glissières trempées et rectifiées
- Hauteur du socle H: ≤ 0,01 mm

Livraison avec:

- Mode d'emploi
- Clé de serrage
- Protocole de mesure

Force de serrage:

KS06010 = 40 kN
KS06020 = 50 kN
KS06030 = 60 kN

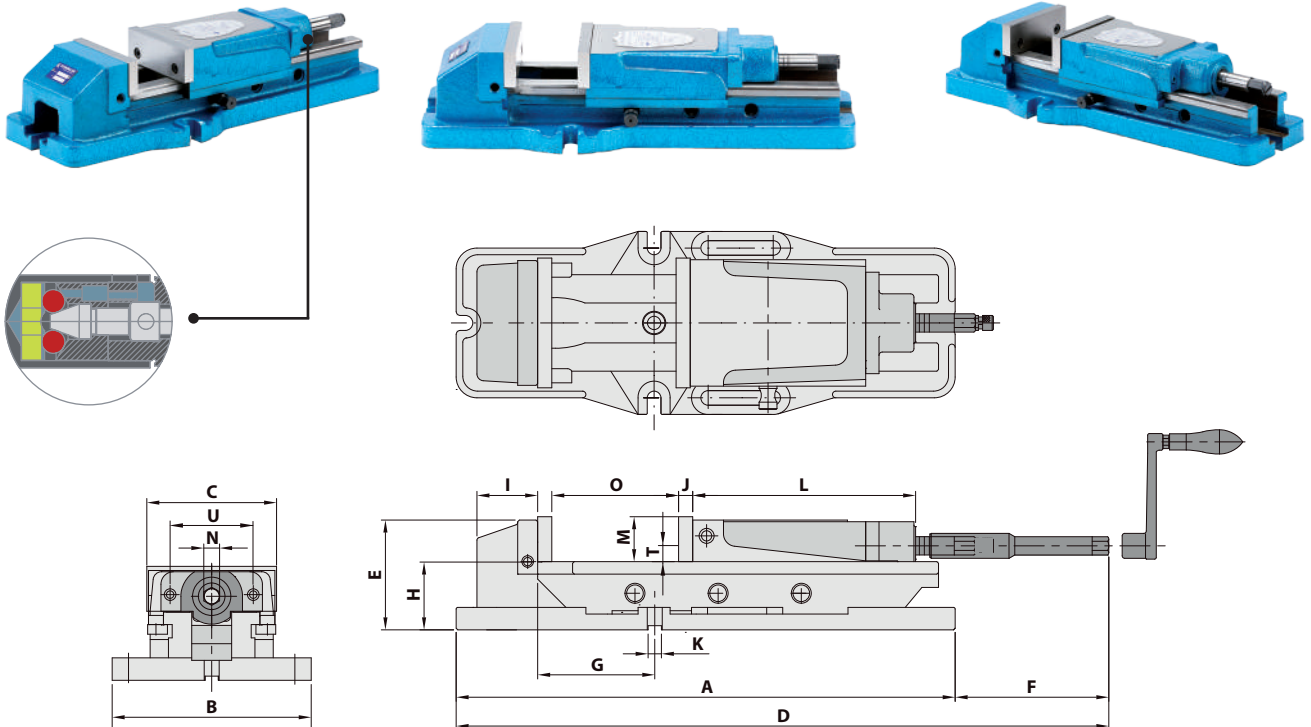

11

Mit patentiertem mechanischem Spannkraftverstärker:

- 1 kein Ölverlust
- 2 genaue Wiederholbarkeit der Spannkraft
- 3 keine Veränderung der Spannkraft
- 4 keine Vibrationen während der Bearbeitung
- 5 lange Lebensdauer

With patented mechanical booster:

- 1 no loss of oil
- 2 exact repeatability of the clamping force
- 3 constant clamping force
- 4 no vibrations during the operation
- 5 long life

Avec l'amplificateur de la force de serrage mécanique patenté:

- 1 pas de perte d'huile
- 2 la répétition précise de la force de serrage
- 3 pas de changement de la force de serrage
- 4 pas de vibrations pendant l'usinage
- 5 longue durée de vie

Bestell-Nr. Order no. Référence	Ausführung Version	A	B	C	D	E	F	G	H	I	J	K	L	M	N	O	P	T	U	kN	kg
KS06010	MP-50A	538	203	130	670	117	132	82	72	82	15	16	175	46	19	220	60	16	85	40	38
KS06020	MP-60A	608	220	154	800	132	180	140	82	74	17	16	208	54	19	300	80	18	100	50	58
KS06030	MP-80A	700	285	206	900	160	200	118	100	113	21	18	245	62	19	300	100	24,5	120	60	104

Precision vices hydraulic Étaux de précision hydraulique

Ausführung:

- Spannkraft voreinstellbar durch Rillenmarkierung
- Horizontal und vertikal aufspannbar
- Führungen geschliffen und gehärtet
- Betthöhe H: $\leq 0,01$ mm

Construction:

- Clamping force preadjustable by graduation lines
- Clamping positions: horizontal and vertical
- Slides hardened and grinded
- Bed height H: $\leq 0,01$ mm

Version:

- Force de serrage pré-réglable par le marquage des rainures
- Positions de serrage: horizontale, ou verticale
- Glissières trempées et rectifiées
- Hauteur du socle H: $\leq 0,01$ mm

Lieferumfang:

- Bedienungsanleitung
- Incl. Spannschlüssel
- Messprotokoll

Delivery:

- Instructions for use
- Wrench
- Test certificate

Livraison avec:

- Mode d'emploi
- Clé de serrage
- Protocole de mesure

Spannkraft:

KS07010 = 25 kN
KS07020 = 35 kN
KS07030 = 44 kN
KS07040 = 66 kN

Clamping force:

KS07010 = 25 kN
KS07020 = 35 kN
KS07030 = 44 kN
KS07040 = 66 kN

Force de serrage:

KS07010 = 25 kN
KS07020 = 35 kN
KS07030 = 44 kN
KS07040 = 66 kN

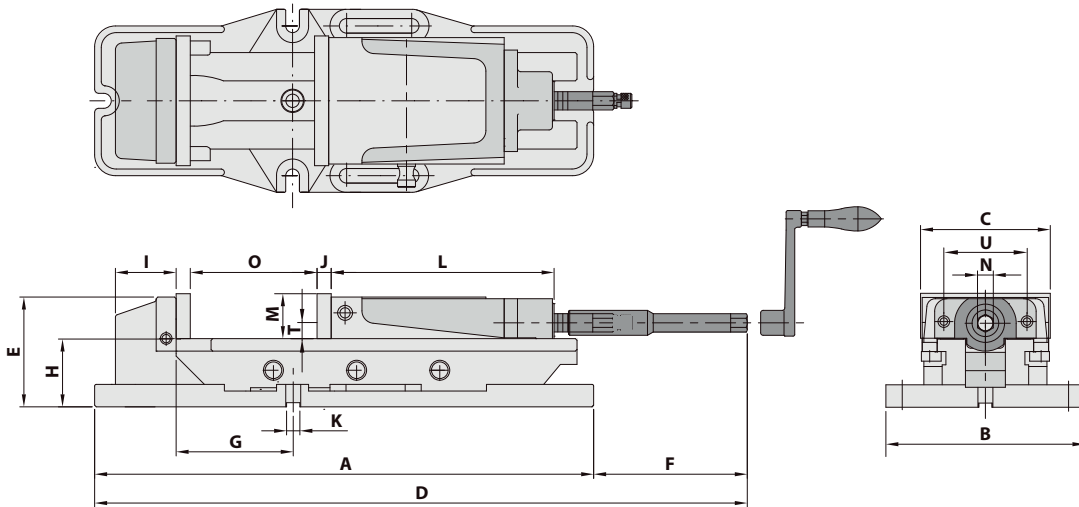

Bestell-Nr. Order no. Référence	Ausführung Version Version	A	B	C	D	E	F	G	H	I	J	K	L	M	N	O	P	T	U	kN	kg
KS07010	HP-40A	435	165	104	525	93	90	63	58	68	11	16	153	36	14	170	-	10	70	25	24
KS07020	HP-50A	538	203	130	670	117	132	82	72	82	15	16	175	46	19	220	-	16	85	35	37
KS07030	HP-60A	608	220	154	800	132	180	140	82	74	17	16	208	54	19	300	-	18	100	44	58
KS07040	HP-80A	700	285	206	900	160	200	118	100	113	21	18	245	62	19	300	-	24,5	120	66	104

K Präzisionsschraubstöcke mechanisch

Precision vices mechanical Étaux de précision mécanique

Ausführung:

- Horizontal, vertikal oder seitlich aufspannbar
- Stahlkörper allseitig geschliffen und gehärtet
- Betthöhe H: $\leq 0,01$ mm

Construction:

- Clamping positions: horizontal, vertical and lateral
- The steel body is hardened and grinded all-round
- Bed height H: $\leq 0,01$ mm

Version:

- Positions de serrage: horizontale, verticale ou latérale
- Corps en acier trempé et rectifié de tous côtés
- Hauteur du socle H: $\leq 0,01$ mm

Lieferumfang:

- Bedienungsanleitung
- Incl. Spannschlüssel
- 4 Stück Spannpratzen
- Zentrier-Nutensteine (Paar)

Delivery:

- Instructions for use
- Wrench
- 4 pcs. vice clamps
- Centering nut (Pair)

Livraison avec:

- Mode d'emploi
- Clé de serrage
- 4 Mors de serrage
- Ecrus à rainure de centrage (Paire)

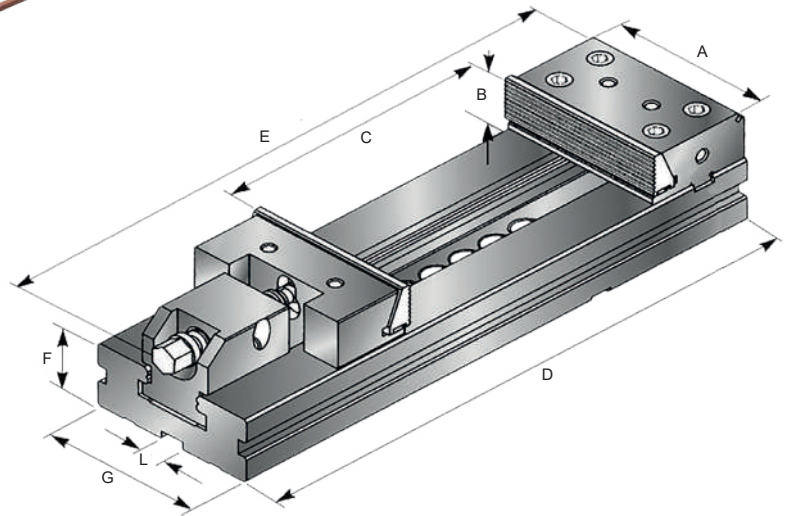
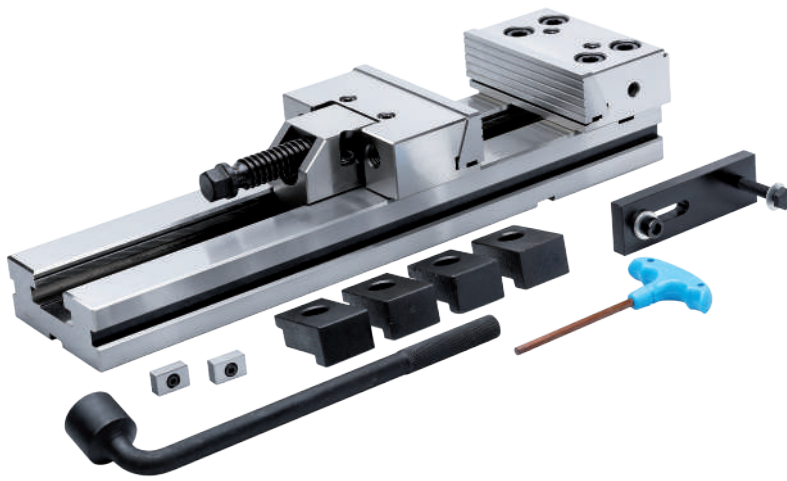

11

Bestell-Nr. Order no. Référence	Ausführung Version Version	A	B	C	D	E	F	G	L	kg
KS30125	ATI-125	125	40	150	345	410	40	95	16	13
KS30150	ATI-150	150	50	300	520	600	50	125	16	29
KS30175	ATI-175	175	60	300	555	630	58	145	16	42
KS30200	ATI-200	200	65	400	695	780	70	170	16	74

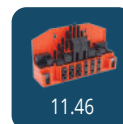
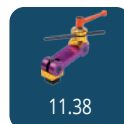

Drehplatte ATI

Swivel base ATI
Plateau tournant ATI

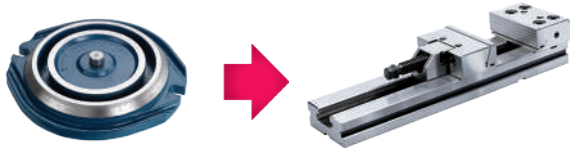

Bestell-Nr. Order no. / Référence	Ausführung Version / Type
Z.KS.30125	ATI-125
Z.KS.30150	ATI-150
Z.KS.30175	ATI-175
Z.KS.30200	ATI-200

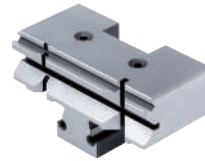

Prismenbacken

Prismatic jaws
Mors prismatiques

Bestell-Nr. Order no. / Référence	Ausführung Version / Type
Z.KS.PR.30125	ATI-125
Z.KS.PR.30150	ATI-150
Z.KS.PR.30175	ATI-175
Z.KS.PR.30200	ATI-200

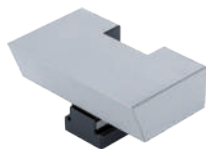

Niederzugbacken

Hold down jaws
Mors de traction vers le bas

Bestell-Nr. Order no. / Référence	Ausführung Version / Type
Z.KS.NZ.30125	ATI-125
Z.KS.NZ.30150	ATI-150
Z.KS.NZ.30175	ATI-175
Z.KS.NZ.30200	ATI-200



Ersatzbacken

Jaws
Mors d'échange

Bestell-Nr. Order no. / Référence	Ausführung Version / Type
Z.KS.SA.30125	ATI-125
Z.KS.SA.30150	ATI-150
Z.KS.SA.30175	ATI-175
Z.KS.SA.30200	ATI-200



Ersatzbacken ALT

Jaws ALT
Mors d'échange ALT

Bestell-Nr. Order no. / Référence	Ausführung Version / Type
Z.KS.ALT4401	ALT-100M/ALT-100L



Ersatzbacken ALT

Jaws ALT
Mors d'échange ALT

Bestell-Nr. Order no. / Référence	Ausführung Version / Type
Z.KS.ALT4402	ALT-100M/ALT-100L

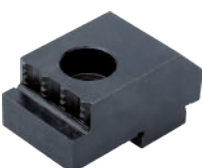

Ersatzbacken ALT

Jaws ALT
Mors d'échange ALT

Bestell-Nr. Order no. / Référence	Ausführung Version / Type
Z.KS.ALT4403	ALT-100M/ALT-100L



Ersatzbacken ALT

Jaws ALT
Mors d'échange ALT

Bestell-Nr. Order no. / Référence	Ausführung Version / Type
Z.KS.ALT4404	ALT-100M/ALT-100L



Schleif- und Kontrollschraubstöcke mit Gewindespindel

Grinding and inspection vices with threaded spindle
Étaux de rectification et de contrôle avec broche filetée

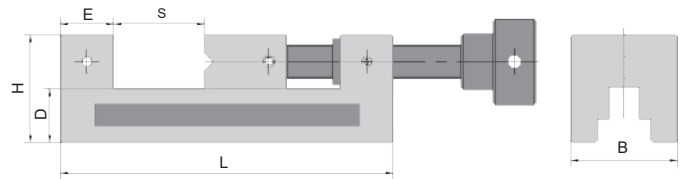
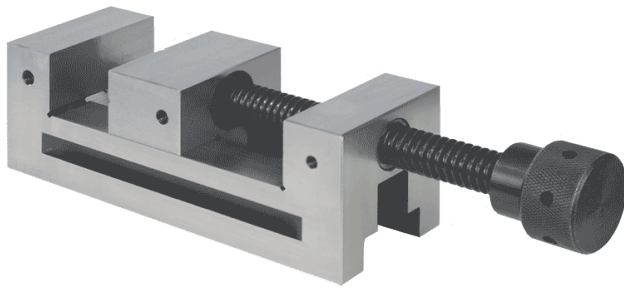

Bestell-Nr. Order no. Référence	B	H	E	D	S _{max}	L	kg
90.11.050	50	50	25	25	65	155	3
90.11.073	73	74	32	39	100	210	5
90.11.100	100	95	38	50	125	260	13

Schleif- und Kontrollschraubstöcke mit Schnellverstellung

Grinding and inspection vices with quick adjustment
Étaux de contrôle et de rectification à réglage rapide

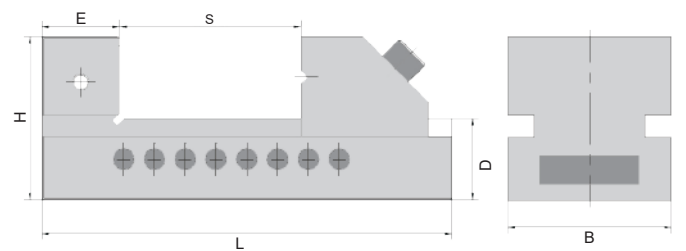
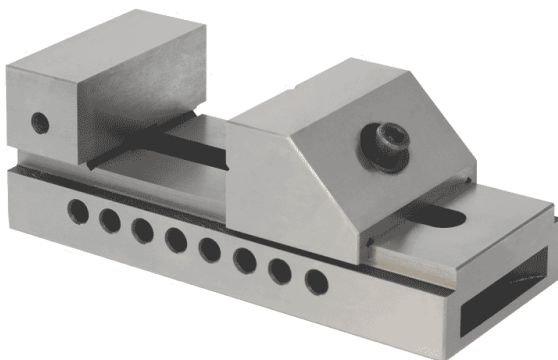

11

Bestell-Nr. Order no. Référence	B	H	E	D	S _{max}	L	kg
90.12.050	50	50	30	25	65	140	2
90.12.073	73	67	35	32	100	190	5
90.12.100	100	90	47	45	125	245	11

Universal, grinding and inspection vices
 Étaux de contrôle et de rectification universel

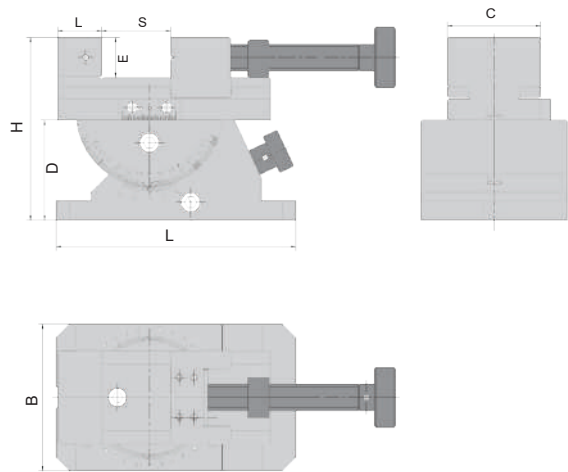
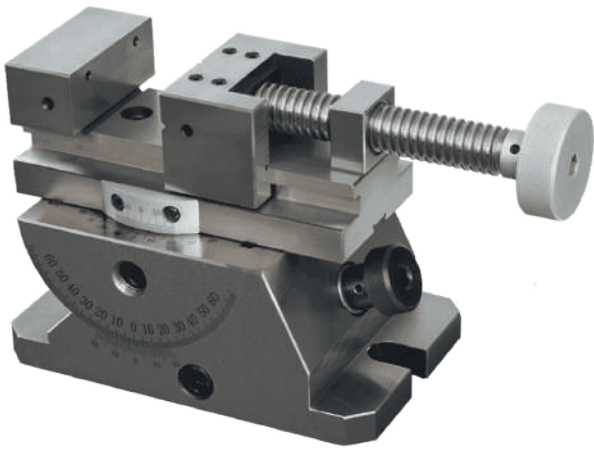

Bestell-Nr. Order no. Référence	B	H	D	E	C	S _{max}	L	kg
90.17.080	110	137	75	30	70	80	180	12

Bohrmaschinenschraubstöcke, mechanisch

Vices for drilling machines, mechanical
 Étaux pour machines à percer, mécanique

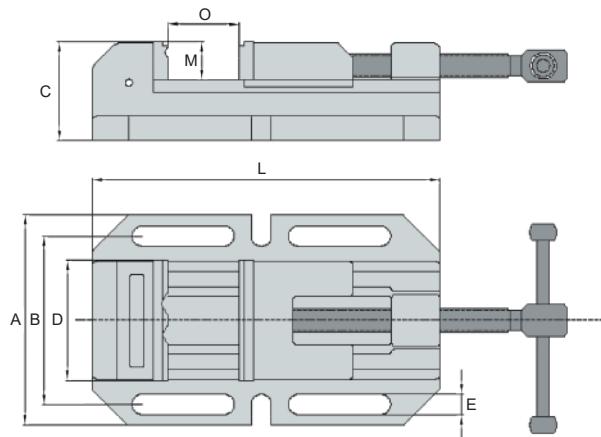

Bestell-Nr. Order no. Référence	Ausführung Version Version	A	B	C	D	E	L	O	M	kg
KS4080	MWM-80	141	111	50	80	11	152	70	22,5	2,3
KS4100	MWM-100	165	133,5	60	100	13,5	190	100	28,5	2,9
KS4150	MWM-150	220	182,5	70	150	15,5	250	150	28,5	5,7
KS4200	MWM-200	265	222,5	89	200	17,5	310	190	45,5	11,5



Ersatzbacken-Paare

Pair of spare jaws
Paire de mors de rechange

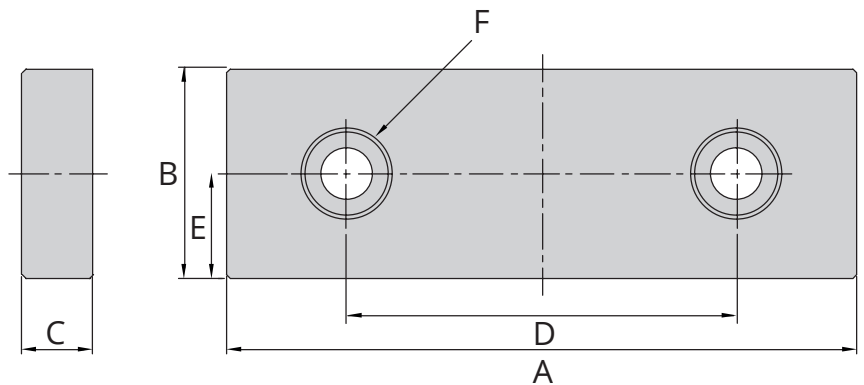

Bestell-Nr. Order no. Référence	Ausführung Version Version	A	B	C	D	E	F
Z.KS.SA.AT409	ATW-40 ATD-460	102	35	15	63,5	17,5	3/8 - 16 UNC
Z.KS.SA.AT509	ATW-50 ATD-570	126	38,1	17	79,4	20,6	7/16 - 14 UNC
Z.KS.SA.ATL609	ATW-675 ATW-689 MG-60 AMC-60 TLD-60 HLD60	151	44,1	18	98,4	23,8	1/2 - 13 UNC
Z.KS.SA.ATL809	ATW-810	206	56	24,2	120	32	5/8 - 11 UNC
Z.KS.SA.AMC409	AMC-40	102	40	21	63,5	17,5	3/8 - 16 UNC
Z.KS.SA.AMP5401	AMP-150	128	52	15	90	25	M10 x 1,5 P
Z.KS.SA.AMP6401	AMP-160 AMP-165	158	55	15	90	25	M10 x 1,5 P
Z.KS.SA.AMP7401	AMP-180	178	60	20	120	28	M12 x 1,75 P
Z.KS.SA.AMP8401	AMP-200 AMP-300	200	60	18	120	28	M12 x 1,75 P

Verwendung:

Für Teile mit empfindlichen Spannflächen

Application:

For parts with delicate clamping surfaces

Usage:

Pour les pièces avec la surface de serrage délicate

11

Werkstoff:

Stahl S50C | Gehärtet HRC 53 +/-2

Material:

Steel S50C | Hardened HRC 53 +/-2

Matériel:

Acier S50C | Trempé HRC 53 +/-2

Pair of spare jaws
Paire de mors de rechange

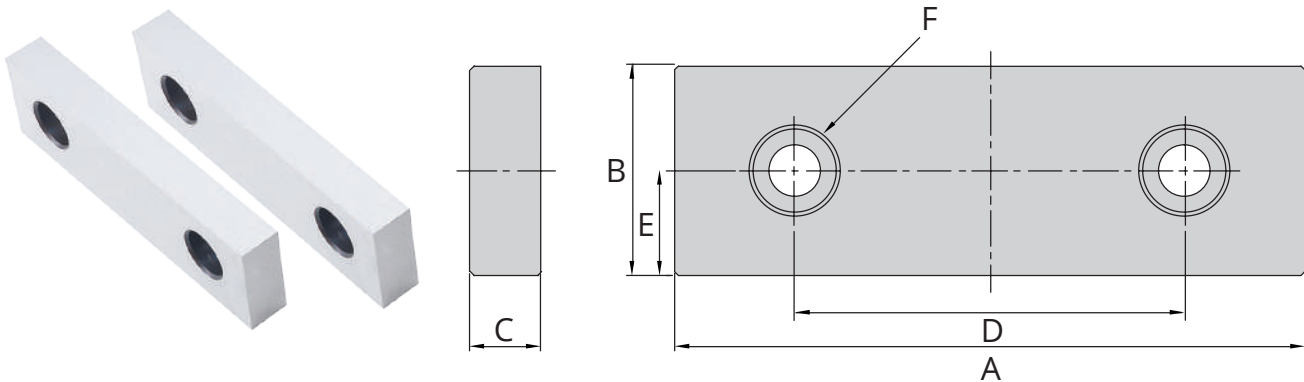

Bestell-Nr. Order no. Référence	Ausführung Version Version		A	B	C	D	E	F
Z.KS.SA.AVQ4401	AVQ-100 AVL-100		102	45	15	58	22,5	M8x 1,25 P
Z.KS.SA.AVQ5401	AVQ-125 AVL-125		124,7	53	15	60	26,5	M10 x 1,5 P
Z.KS.SA.AVQ6401	AVQ-160 AVL-160 ALQ-160		159,2	53	18	98,4	26,5	M12 x 1,75 P
Z.KS.SA.AVQ8401	AVQ-200 AVL-200 ALQ-200 AOM-200		199,5	58	18	120	29	M12 x 1,75 P
Z.KS.SA.HP403	HP-40		104	36	11	70	10	1/4 - 20 UNC
Z.KS.SA.HP503	HP-50 MP-50		130	46	15	85	16	5/16 - 18 UNC
Z.KS.SA.HP603	HP-60 MP-60		154	54	17	100	18	3/8 - 16 UNC
Z.KS.SA.HP803	HP-80 MP-80		206	62	21	120	24,5	M10 x 1,5 P
Z.KS.SA.AVC6401	AVC-160 AVM-160		160	58	15	90	25	M10 x 1,5 P
Z.KS.SA.AVC8401	AVC-200 AVM-200		200	63	18	120	28	M12 x 1,75 P
Z.KS.SA.TLD4401	TLD-40	2 Paar 2 pair 2 paire	102	38	15	63,5	17,5	3/8 - 16 UNC
Z.KS.ST.ALD6401	ALD-60	2 Paar 2 pair 2 paire	152	58	17	95	32	M12 x 1,75 P

Verwendung:

Für Teile mit empfindlichen Spannflächen

Application:

For parts with delicate clamping surfaces

Usage:

Pour les pièces avec la surface de serrage délicate

Werkstoff:

Stahl S50C | Gehärtet HRC 53 +/-2

Material:

Steel S50C | Hardened HRC 53 +/-2

Matériel:

Acier S50C | Trempé HRC 53 +/-2

K Prismenbacken

Prismatic jaws
Mors prismatiques

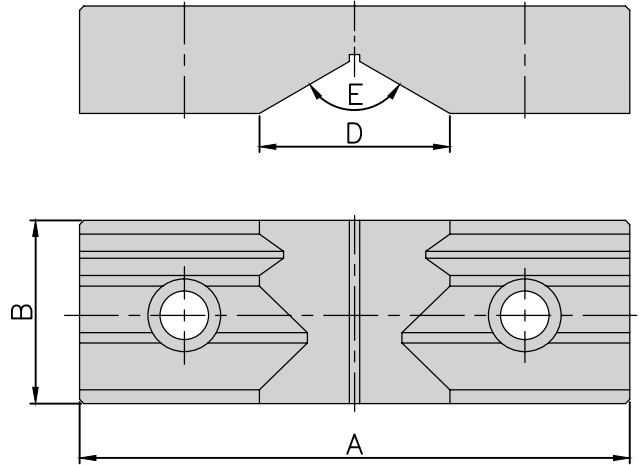
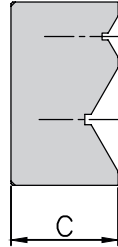

Bestell-Nr. Order no. Référence	Ausführung Version Version	A	B	C	D	E
Z.KS.PR.AT409R	ATW-40 ATD-460	102	35	31	40	120°
Z.KS.PR.AT509R	ATW-50 ATD-570	126	38,1	31	40	120°
Z.KS.PR.AT609R	ATW-675 689 MG-60 AMC-60 TLD-60 HLD60	151	44,5	31	45	120°
Z.KS.PR.AT809R	ATW-810	206	60	36	60	120°
Z.KS.PR.AMC409R	AMC-40	102	40	30	40	120°
Z.KS.PR.AVQ4407	AVQ-100 AVL-100	102	45	28	36,3	120°
Z.KS.PR.AVQ5407	AVQ-125 AVL-125	124,7	53	31	50	120°
Z.KS.PR.AVQ6407	AVQ-160 AVL-160 ALQ-160 AOM-160	159,2	53	31	55	120°
Z.KS.PR.AVQ8407	AVQ-200 AVL-200 ALQ-200 AOM-200	200	56	31	55	120°
Z.KS.PR.HP403R	HP-40	104	36	31	40	120°
Z.KS.PR.HP503R	HP-50 MP-50	130	46	31	45	120°
Z.KS.PR.HP603R	HP-60 MP-60	154	54	31	55	120°
Z.KS.PR.HP803R	HP-80 MP-80	206	62	36	60	120°
Z.KS.PR.AVC6407	AVC-160 AVM-160	160	58	30	55	120°
Z.KS.PR.AVC8407	AVC-200 AVM-200	200	63	36	70	120°
Z.KS.PR.TLD4407	TLD-40 1 Paar 1 pair 1 paire	102	38	31	40	120°
Z.KS.PR.ALD6404	ALD-60 1 Paar 1 pair 1 paire	152	58	49	55	120°

11

Verwendung:

Zum Spannen von runden Bauteilen.
vertikal \varnothing 16 - 74 mm, horizontal \varnothing 12 - 40 mm

Application:

For clamping cylindrical components.
vertical \varnothing 16-74 mm, horizontal \varnothing 12-40 mm

Usage:

Pour le serrage de pièces rondes.
vertical \varnothing 16 - 74 mm, \varnothing horizontal 12 - 40 mm

Werkstoff:

Stahl S50C | Gehärtet HRC 53 +/-2

Material:

Steel S50C | Hardened HRC 53 +/-2

Matériel:

Acier S50C | Trempé HRC 53 +/-2

Step jaws (Pair)
Mors étagés (Paire)

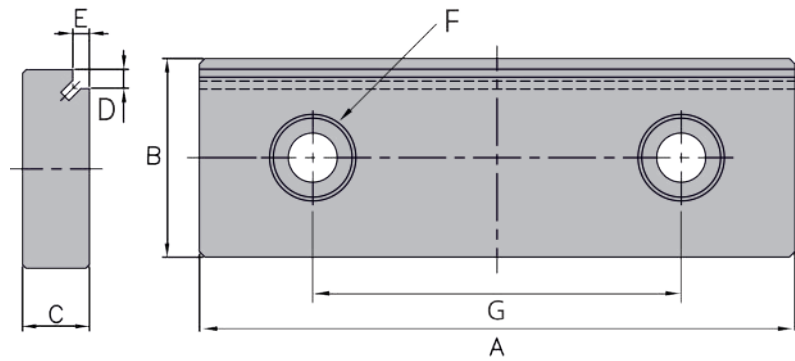

Bestell-Nr. Order no. Référence	Ausführung Version Version	A	B	C	D	E	F	G
Z.KS.ST.AT409L	ATW-40 ATD-460	102	35	15	4	3,5	3/8 - 16 UNC	63,5
Z.KS.ST.AT509L	ATW-50 ATD-570	126	38,1	17	4	3,5	7/16 - 14 UNC	79,4
Z.KS.ST.AT609L	ATW-675 ATW-689 MG-60 AMC-60 TLD-60 AMC-60 TLD-60 HLD-60	151	44,5	18	5	4,5	1/2 - 13 UNC	98,4
Z.KS.ST.AT809L	ATW-810	206	56	24,2	6	5,5	5/8 - 11 UNC	120
Z.KS.ST.AMC409L	AMC-40	102	40	21	4	3,5	3/8 - 16 UNC	63,5
Z.KS.ST.AVQ4404	AVQ-100 AVL-100	102	45	15	5	5	M8x 1,25 P	58
Z.KS.ST.AVQ5404	AVQ-125 AVL-125 ALQ-125	124,7	53	15	5	5	M10 x 1,5 P	60
Z.KS.ST.AVQ6404	AVQ-160 AVL-160 ALQ-160	159,2	53	18	5	4,5	M12 x 1,75 P	98,4
Z.KS.ST.AVQ8404	AVQ-200 AVL-200 ALQ-200 AOM-200	200	56	18	4	5	M12 x 1,75 P	120
Z.KS.ST.HP403L	HP-40	104	36	11	3,5	4	1/4 - 20 UNC	70
Z.KS.ST.HP503L	HP-50 MP-50	130	46	15	5	5	5/16 - 18 UNC	85
Z.KS.ST.HP603L	HP-60 MP-60	154	54	17	5	5	3/8 - 16 UNC	100
Z.KS.ST.HP803L	HP-80 MP-80	206	62	21	5,5	6	M10 x 1,5 P	120
Z.KS.ST.AVC6404	AVC-160 AVM-160	160	58	15	5	5	M10 x 1,5 P	90
Z.KS.ST.AVC8404	AVC-200 AVM-200	200	63	18	5	5	M12 x 1,75 P	120
Z.KS.ST.TLD4402	TLD-40	102	38	15	8	5	3/8 - 16 UNC	63,5
Z.KS.ST.ALD6401	ALD-60	152	58	17	8	5	M12 x 1,75 P	95

Verwendung:
Für das horizontale Spannen von flachen Werkstücken

Application:
For horizontal clamping of flat workpieces

Usage:
Pour le serrage horizontal de pièces plates

Werkstoff:
Stahl S50C | Gehärtet HRC 53 +/-2

Material:
Steel S50C | Hardened HRC 53 +/-2

Matériel:
Acier S50C | Trempé HRC 53 +/-2



Geriffelte Backen / Rillenbacken (Paar)

Serrated jaws (Pair)
Mors cannelés (Paire)

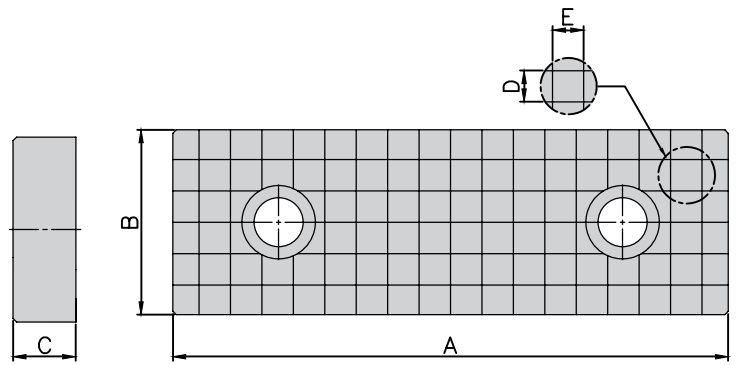
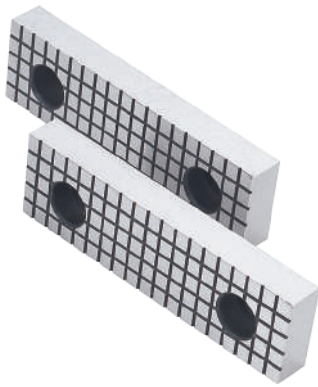

Bestell-Nr. Order no. Référence	Ausführung Version Version	A	B	C	D	E	
Z.KS.GR.AT409T	ATW-40 ATD-460	102	35	15	9	9	
Z.KS.GR.AT509T	ATW-50 ATD-570	126	38,1	17	9	9	
Z.KS.GR.AT609T	ATW-675 ATW-689 MG-60 AMC-60 TLD-60 HLD-60	151	44,5	18	8	8	
Z.KS.GR.AT809T	ATW-810	206	60	24,2	8	8	
Z.KS.GR.AMC409T	AMC-40	102	40	21	9	9	
Z.KS.GR.AVQ4405	AVQ-100 AVL-100	102	45	15	9	9	
Z.KS.GR.AVQ5405	AVQ-125 AVL-125	124,7	53	15	9	9	
Z.KS.GR.AVQ6405	AVQ-160 AVL-160 ALQ-160 AOM-160	159,2	53	18	9	9	
Z.KS.GR.AVQ8405	AVQ-200 AVL-200 ALQ-200 AOM-200	200	56	18	9	9	
Z.KS.GR.HP403T	HP-40 MP-40	104	36	11	8	8	
Z.KS.GR.HP503T	HP-50 MP-50	130	46	15	8	8	
Z.KS.GR.HP603T	HP-60 MP-60	154	54	17	8	8	
Z.KS.GR.HP803T	HP-80 MP-80	206	100	30	8	8	
Z.KS.GR.AVC6405	AVC AVM-160	160	58	15	8	8	
Z.KS.GR.AVC8405	AVC AVM-200	200	63	18	8	8	
Z.KS.GR.TLD4405	TLD-40	2 Paar 2 pair 2 paire	102	38	15	9	9
Z.KS.GR.ALD6405	ALD-60	2 Paar 2 pair 2 paire	152	58	49	25	25

11

Verwendung:

Zur Erhöhung der spezifischen Flächenpressung

Application:

To increase the specific contact pressure per unit area

Usage:

Pour augmentation de la pression spécifique de la surface

Werkstoff:

Stahl S50C | Gehärtet HRC 53 +/-2

Material:

Steel S50C | Hardened HRC 53 +/-2

Matériel:

Acier S50C | Trempé HRC 53 +/-2

Niederzugbacken (Paar)



Hold down jaws (Pair)

Mors de tirage vers le bas (Paire)

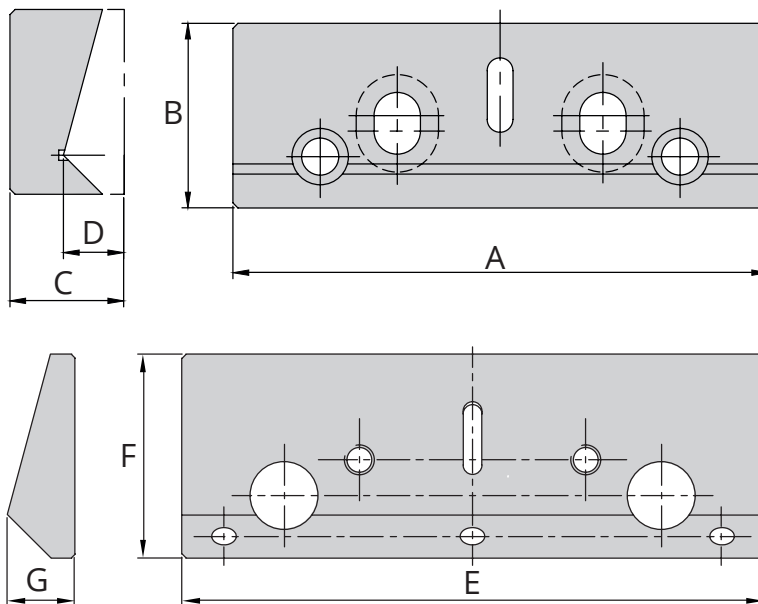

Bestell-Nr. Order no. Référence	Ausführung Version Version	A	B	C	D	E	F	G
Z.KS.NZ.HP403DA	HP-40	104	36	22,2	11,8	104	36	12
Z.KS.NZ.HP503DA	HP-50 MP-50	130	46	26,4	15,1	130	46	15,1
Z.KS.NZ.HP603DA	HP-60 MP-60	154	54	29,4	18	154	54	18
Z.KS.NZ.HP803DA	HP-80 MP-80	206	62	29,4	21	206	62	21

Verwendung:

Hohe Stabilität bei der Werkstückbearbeitung durch aktiven Niederzug

Application:

High stability during workpiece machining due to the active pull-down

Usage:

Haute résistance lors de l'usinage de la pièce grâce à une traction vers le bas en mode actif

Werkstoff:

Stahl S50C | Gehärtet HRC 53 +/-2

Material:

Steel S50C | Hardened HRC 53 +/-2

Matériel:

Acier S50C | Trempé HRC 53 +/-2



Krallenbacken (Paar)

Claw jaws (Pair)
Mors à griffes (Paire)

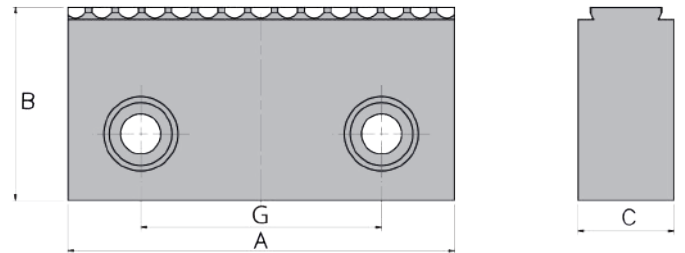

Bestell-Nr. Order no. Référence	Ausführung Version Version	A	B	C	G
Doppelverzahnung double toothing double denture					
Z.KS.KB.ATD409	ATW-40 / ATD-460	102	50,8	25,4	63,5
Z.KS.KB.ATD509	ATW-50 / ATD-570	126	57,15	25,4	79,4
Z.KS.KB.ATL609	ATW-675 u.a.	152,4	63,5	25,4	98,4
Z.KS.KB.ATL809	ATW-810	203	63,5	25,4	120
Einfachverzahnung single toothing denture unique					
Z.KS.KB.AVQ5401	AVQ-125 AVL-125	124,7	58,0	18,0	60
Z.KS.KB.AVQ6401	AVQ AVL ALQ -160	159,2	58	20	98,4
Z.KS.KB.AVQ8401	AVQ AVL ALQ AOM-200	199,5	63	20	120

Verwendung:

Drei bis vier Mal höhere Haltekräfte als Standard-Aufsatzbacken

Application:

High clamping forces: increased by three or four times compared to standard top jaws

Usage:

Force de maintien trois à quatre fois plus élevée par rapport aux mors standards

11

Werkstoff:

Stahl S50C | Gehärtet HRC 53 +/-2

Material:

Steel S50C | Hardened HRC 53 +/-2

Matériel:

Acier S50C | Trempé HRC 53 +/-2

Knarre mit Nuss für ALQ, AVQ und AVL Schraubstöcke



Ratched with nut for ALQ, AVQ and AVL vices

Clé à cliquet avec douille pour les etaux ALQ, AVQ et AVL



Bestell-Nr.
Order no.
Référence

DRVS

Z.KS.OB5020.OB5032

19

Handkurbel für ALQ, AVQ und AVL Schraubstöcke

Handle for ALQ, AVQ and AVL vices

Poignée de manivelle pour les etaux ALQ, AVQ et AVL



Bestell-Nr.
Order no.
Référence

DRVS

Z.KS.ALQ629A

19



Werkstückanschlag ATW

Workpiece stop ATW
Dispositif de butée ATW

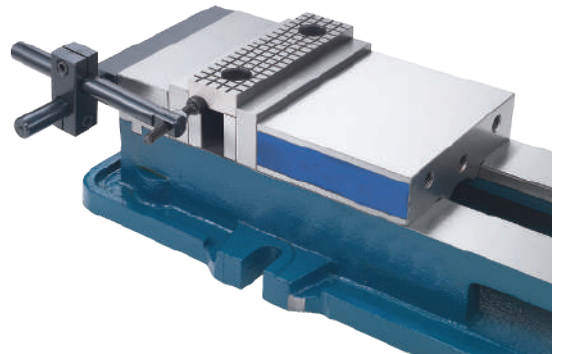
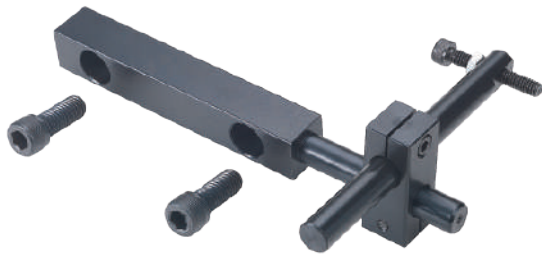

Bestell-Nr. Order no. Référence	Ausführung Version Version
Z.KS.ATW40ST	4" ATW-40 ATD-460
Z.KS.ATW50ST	5" ATW-50 ATD-570
Z.KS.ATW60ST	6" ATW-675 ATW-689
Z.KS.ATW80ST	8" ATW-810

Ausführung:

Stufenlose und schnelle Einstellung.

Direktmontage auf Standard-Vorsatzbacken bei NC-Schraubstöcken.

Verwendung:

Für den Einsatz auf Fräs- und Bohrmaschinen.

Version:

Stepless and quick adjustment.

Direct mounting on standard front jaws for NC vices.

Application:

For use on milling and drilling machines.

Version:

Réglage continu et rapide.

Montage direct sur les mors standards pour les étaux NC.

Usage:

Pour l'usage sur les machines de fraisage et les machines de perçage.

Workpiece back-stop, universal 3-dimensional
Dispositif de butée, universel 3D



Bestell-Nr.
Order no.
Référence

Z.KS.ATS160BH

Ausführung
Version
Version

ATS-160BH / T-16mm

Ausführung:

5 Achsen stufenlos 360° drehbar.
Stufenlose und schnelle Einstellung.
M8-Aufnahme für Nutensteine oder Direktmontage.

Verwendung:

Für den Einsatz auf Fräs- und Bohrmaschinen.

Werkstoff:

Aluminium eloxiert

Version:

*5 axes with stepless 360° rotation.
Quick and stepless adjustment.
M8 mounting for T-nuts or direct mounting.*

Application:

For use on milling and drilling machines.

Material:

Anodised aluminium.

Version:

5 axes à réglage continu, rotation à 360°.
Réglage continu et rapide.
Réception M8 pour écrous à rainure ou pour installation directe.

Usage:

Pour l'usage sur les machines de fraisage et les machines de perçage.

Matière(s):

Aluminium anodisé.



Winkelprisma, einstellbar

Adjustable prism square
Équerre à prisme, ajustable

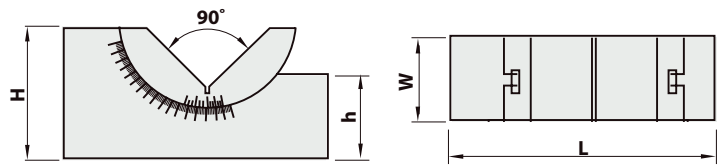

Bestell-Nr. Order no. Référence	L	W	H	h
GAP-25	75	25	36	25
GAP-30	102	30	49	30
GAP-46	102	46	49	30

Ausführung:

Aus gehärtetem Stahl, entspannt und feingeschliffen.
Winkelablesung bzw. Einstellung über Nonius.
Mit Feststellschraube arretierbar.

Winkelgenauigkeit = 10 Winkelmin.
Winkelablesung = 10 Winkelmin.
Ebenheitstoleranz = 0,01mm

Version:

Made of hardened steel, stress-relieved and finely ground.
Angle reading or setting via vernier.
Lockable with locking screw.

Angular accuracy = 10 angle min.
Angle reading = 10 angle min.
Flatness tolerance = 0.01mm

Version:

Fabriqué en acier trempé, détendu et finement rectifié.
Lecture d'angle ou réglage par vernier.
Peut être bloqué avec une vis de blocage.

Précision angulaire = 10 angle min.
Mesure d'angle = 10 angle min.
Tolérance de planéité = 0,01 mm

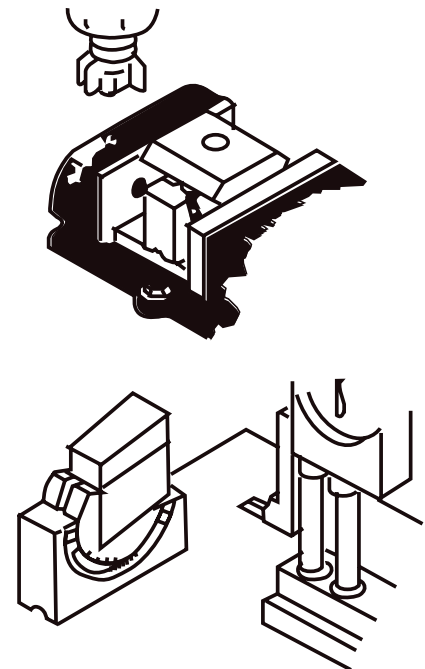

Clamping sets 4-parts

Jeu de brides de serrage 4 pieces



Verwendung:

Zum konventionellen Befestigen auf dem Maschinentisch.

Application:

For conventional fastening to the machine table.

Usage:

Pour la fixation standard sur la table de la machine.

Bestell-Nr. Order no. Référence	Ausführung Version Version
Z.KS.AVQ690102	14mm T-Nut
Z.KS.AVQ690104	16mm T-Nut
Z.KS.AVQ690106	18mm T-Nut
Z.KS.AVQ690105	20mm T-Nut

Zentrier-Nutensteine (Paar)

Centering nut (Pair)

Coulisseaux de centrage (Paire)



Bestell-Nr. Order no. Référence	Ausführung Version Version
Z.KS.N.ATD570-14	16 - 14
Z.KS.N.AVQ.18-12	18 - 12
Z.KS.N.ATW689-14	18 - 14
Z.KS.N.ATW689	18 - 16
Z.KS.N.STANDARD	18 - 18



T-Nuten (T-Nutensteine mit Gewinde)

T-Nuts (T-nut with thread)

Tasseaux (Tasseau en forme T avec filetage)

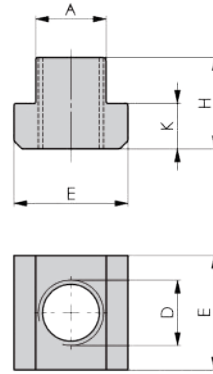

Bestell-Nr. Order no. Référence	Ausführung Version Version	A	D	E	H	K
Z.KS.80010	M6x8	7,7	M6	13	10	6
Z.KS.80028	M8x10	9,7	M8	15	12	6
Z.KS.80036	M10x12	11,7	M10	18	14	7
Z.KS.80234	M10x14	13,7	M10	22	16	8
Z.KS.80366	M10x16	15,7	M10	25	18	9
Z.KS.81265	M10x18	17,7	M10	28	20	10
Z.KS.80168	M12x16	15,7	M12	25	18	9
Z.KS.80051	M14x16	15,7	M14	25	18	9
Z.KS.80176	M14x18	17,7	M14	28	20	10
Z.KS.80077	M18x20	19,7	M18	32	24	12
Z.KS.80242	M18x22	21,7	M18	35	28	14
Z.KS.80093	M22x24	23,7	M22	40	32	16

Verwendung:

Zur Kombination mit Stiftschrauben nach Norm.

Norm:

DIN 508

Werkstoff:

Vergütungsstahl, Festigkeit 10.

Hinweis:

Volle Belastbarkeit nur bei Verschraubung über die gesamte Gewindelänge.

Application:

For combination with studs or bolts.

Standard:

DIN 508

Material:

Quenched and tempered steel, strength 10.

Note:

Full load-bearing capacity only when threaded for the entire nut length.

Utilisation:

Pour la fixation avec des goujons selon la norme.

Norme:

DIN 508

Matière(s):

Acier trempé et revenu, résistance 10.

Remarque(s):

Capacité de charge maximale uniquement en cas de fixation sur toute la longueur du filetage.

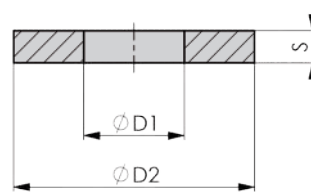
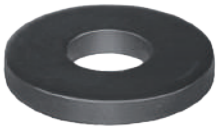

Bestell-Nr. Order no. Référence	Ausführung Version Version	D1	D2	S
Z.KS.82818	M6	6,4	17	2
Z.KS.82826	M8	8,4	23	4
Z.KS.82834	M10	10,5	28	4
Z.KS.82859	M14	15	40	5
Z.KS.82875	M18	19	45	6
Z.KS.82891	M22	23	50	8

Ausführung:

Extra stark, plan gepresst und gehärtet, Kanten gebrochen.

Verwendung:

Besonders geeignet für Spanneisen.

Speziell für den Vorrichtungsbau.

Norm:

DIN 6340

Version:

Extra strong, flat-pressed and hardened, edges bevelled.

Application:

Particularly suitable for clamps.

Especially for making jigs and fixtures.

Standard:

DIN 6340

Version:

Extra fort, pressé à plat et durci, arêtes brisées.

Usage:

Convient particulièrement pour les brides de serrage.

Spécial pour la construction de montages.

Norme:

DIN 6340



Stiftschrauben DIN 6379

Studs DIN 6379
Goujons DIN 6379

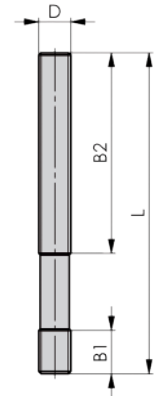

Bestell-Nr. Order no. Référence	Ausführung Version Version	B1	B2
Z.KS.84780	M6x50	9	30
Z.KS.81257	M8x40	11	20
Z.KS.81299	M10x50	13	25
Z.KS.84830	M10x80	13	50
Z.KS.81372	M14x63	17	32
Z.KS.84954	M18x125	23	75
Z.KS.86561	M18x160	23	100
Z.KS.81539	M22x160	31	100

Ausführung:

Gewinde gerollt

Verwendung:

Zur individuellen Zusammenstellen von T-Nuten-Schrauben in Verbindung mit Nutensteinen Nr. 375315 – 375330, Muttern Nr. 375385 – 378395 und Unterlegscheiben Nr. 375340 – 375360.

Norm:

DIN 6379

Werkstoff:

Vergütungsstahl

Festigkeitsklasse:

M6 – M12 = 10.9

M14 – M30 = 8.8

Version:

Rolled thread.

Application:

For individual combination of T-bolts in conjunction with T-nuts and tenons No. 375315 – 375330, nuts No. 375385 – 378395 and plain washers No. 375340 – 375360.

Standard:

DIN 6379

Material:

Heat-treated steel

Strength class:

M6 – M12 = 10.9

M14 – M30 = 8.8

Version:

Filet roulé.

Utilisation:

Pour l'usage avec les vis pour rainures en forme T ensemble avec les tasseaux 375315 – 375330, les écrous 375385 – 378395 et les écrous 375340 – 375360.

Norme:

DIN 6379

Matière(s):

Acier trempé et revenu

Catégorie de résistance:

M6 – M12 = 10.9

M14 – M30 = 8.8

Fixture nuts DIN 6330B
Écrou hexagonal DIN 6330B

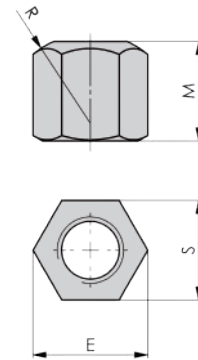

Bestell-Nr. Order no. Référence	Ausführung Version Version	E	M	R	S
Z.KS.82362	M6	11,05	9	9	10
Z.KS.82370	M8	14,40	12	12	13
Z.KS.82354	M10	17,80	15	15	16
Z.KS.82321	M14	23,40	21	20	21
Z.KS.82420	M18	30,10	27	24	27
Z.KS.82339	M22	37,70	33	30	34

Ausführung:

Hohe Mutter (= 1,5 d hoch) mit einem flachen Ende zur Auflage auf Unterlegscheiben DIN 6340 und einem kugeligen Ende zur Auflage in Kegelpfannen DIN 6319D oder DIN 6319G.

Norm:

DIN 6330 B

Werkstoff:

Vergütungsstahl, Festigkeit 10.

Version:

Tall nut (= 1.5 d tall) with one flat face to rest on plain washer DIN 6340 and a convex face for positioning in collared washer DIN 6319D oder DIN 6319G.

Standard:

DIN 6330 B

Material:

Quenched and tempered steel, strength 10.

Version:

Écrou long (= 1,5 d de hauteur) avec la surface plate destinée à être posée sur une rondelle plate DIN 6340 et avec la surface sphérique destinée à être posée sur une rondelle à collerette DIN 6319D ou DIN 6319G.

Norme:

DIN 6330 B

Matière(s):

Acier trempé et revenu, résistance 10.

K Drehplatte

Swivel base
Plateau tournant

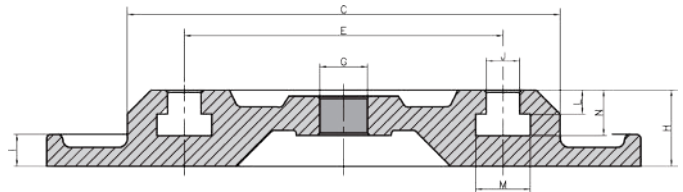
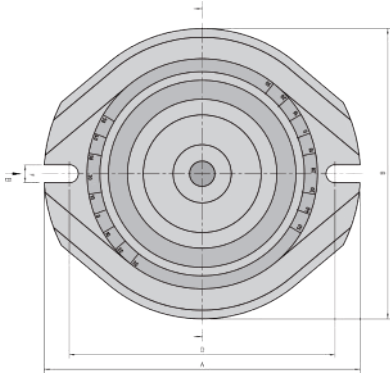

Bestell-Nr. Order no. Référence	Ausführung Version Version	A	B	C	D	E	F	G	H	I	J	L	M	N
Z.KS.HP402A	HP-40	233	220	167	197	125	12	16	25	25	11	7	19	15
Z.KS.HP502A	HP-50 / MP-50	272	260	212	239	160	18	16	33	33	14	10	26	22
Z.KS.HP602A	HP-60 / MP-60	327	322	255	286	201	20	16	37	37	18	12	32	23
Z.KS.HP802A	HP-80 / MP-80	410	410	305	370	240	20	16	46	46	18	15	36	27
Z.KS.AT413A	ATW-40 / ATD-460	250	230	182	210	134	14	20	32	13,5	14	10	23,5	19
Z.KS.AT513A	ATW-50 / ATD-570	275	257	212	239	163	14	20	36	13,5	14	10	23,5	19
Z.KS.AT613A	ATW-675 / ATW689	320	300	255	280	191	20	25	42	14,5	17,5	13	34	30
Z.KS.AT813A	ATW-810	400	380	320	356	250	20	30	49	20	17	15	32	33

Merkmal:

Auflagerand geschliffen, 360° Teilstriche zur Winkeleinstellung, Fixiernut 16H / 20H7.

Feature:

Bearing edge ground, 360° graduations for angular adjustment, 16H7 / 20H7 fixing slot.

Caractéristique(s):

Bord de support rectifié, graduations de 360° pour le réglage de l'angle, rainure de fixation 16H / 20H7.

Clamping sets / Basic assortment of clamping elements
 Jeux de serrage / Ensemble d'outils de serrage de base



Verwendung:

Zum konventionellen Befestigen auf dem Maschinentisch.

Application:

For conventional fastening to the machine table.

Usage:

Pour la fixation standard sur la table de la machine.

Bestell-Nr. Order no. Référence	Gewinde Thread Filetage	T-Nuten-Nennmaß T-slot nominal size Dim. nom. rain. T
Z.KS.ACK08	M8x1,25	10mm T-Nut
Z.KS.ACK10	M10x1,5	12mm T-Nut
Z.KS.ACK12A	M12x1,75	14mm T-Nut
Z.KS.ACK12B	M12x1,75	16mm T-Nut
Z.KS.ACK12C	M12x1,75	18mm T-Nut

Merkmal:

Alle Teile aus Vergütungsstahl gefertigt.
 T-Nutenschrauben vergütet, Gewinde gerollt.

Feature:

All parts made of quenched and tempered steel.
 T-slot bolts quenched and tempered, rolled thread.

Caractéristique(s):

Toutes les pièces sont fabriquées en acier trempé et revenu
 Vis à rainure en forme T trempées, filetage roulé.

K Parallel-Unterlagen-Sätze

Set of parallel supports
Jeu de supports parallèles



Verwendung:

Parallelunterlagen finden vielseitige Verwendung als Hilfsmittel zum Spannen und Positionieren z.B. beim Schleifen, Fräsen, Erodieren, Messen und Anreissen.

Application:

Parallels are widely used for clamping and positioning, f.e. during grinding, milling, eroding, measuring and scribing.

Usinage:

Les jeux de supports parallèles sont souvent utilisés comme outils de serrage et de placement, par exemple pour la rectification, le fraisage, l'érosion, la mesure et le traçage.

Bestell-Nr. Order no. Référence	Anzahl Leisten Number of strips Nombre de cales	OAL	OAB	OAH
91.12.150.1	14 Paar / pairs / paires	150	10	14 - 16 - 18 - 20 - 22 - 24 - 26 - 28 - 30 - 32 - 35 - 40 - 45 - 50
91.12.150.2	14 Paar / pairs / paires	150	8	14 - 16 - 18 - 20 - 22 - 24 - 26 - 28 - 30 - 32 - 35 - 40 - 45 - 50
91.12.200.3	14 Paar / pairs / paires	200	10	14 - 16 - 18 - 20 - 22 - 24 - 26 - 28 - 30 - 32 - 35 - 40 - 45 - 50
91.13.100.1	9 Paar / pairs / paires	100	4	10 - 14 - 18 - 22 - 26 - 30 - 34 - 38 - 42

Härte: HRC 55 - 62
Hardness: HRC 55 - 62
Dureté: HRC 55 - 62

Genauigkeit: 0,01mm
Accuracy: 0,01mm
Exactitude: 0,01mm

Parallelität: 0,005mm
Parallelism: 0,005mm
Parallélisme: 0,005mm

Reversible ratchet | 1/2" with ejector Cliquet réversible | 1/2" avec éjecteur

Ausführung:

Materialauswahl und spezielle Schmiedeverfahren garantieren optimale Funktion und lange Lebensdauer. Mit Umschalthebel für Rechts- und Linksgang.

Norm:
Außenvierkante nach
DIN 3120-A 12,5 mit federnder Kugel

Passend für:
Handbetätigte Einsätze

Version:

Material selection and special forging process guarantee optimal functioning and long life. With reversing lever for right-hand and left-hand threads.

Standard:
External square drives to
DIN 3120-A 12.5 with spring ball.

Suitable for:
Manual use

Version:

Fonctionnement optimal et longue durée de vie grâce à la sélection des matériaux et grâce au forgeage spécial. Avec levier d'inversion droite / gauche

Norme:
Carrés conducteurs mâles suivant
DIN 3120-A 12,5 avec bille à ressort.

Adapté(s) pour:
Douilles actionnées à la main

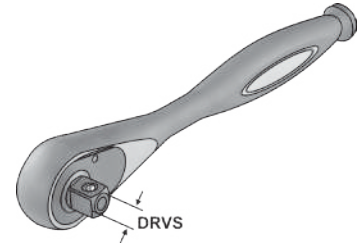

Bestell-Nr. Order no. Référence	DRVS	OAL	Zähnezahl No. of teeth Nombre de dents
800.KS.05	1/2"	250	24

Steckschlüssel Einsätze | 6-kant-Einsatz |

Hexagon socket Douille 6 pans

Ausführung:

Aus hochwertigem Stahl geschmiedet, innen angesenkt für schnelles Erfassen der Schraubenköpfe. Innenvierkante nach DIN 3120. Die Surface Drive-Schlüsselöffnung erlaubt einen festeren Passsitz und eine höhere Wirkungskraft. Der Druck wirkt direkt auf die Fläche der Muttern und Schrauben, empfindliche Kanten werden geschont. Auch Zwischenmaße z. B. in Zoll (A/F, BSF, BSW) und abgenutzte Schrauben können mit dem Surface Drive angezogen oder gelöst werden.

Version:

Forged from high quality steel, internally bevelled for easy fitting to bolt heads. Square socket drives to DIN 3120. The Surface Drive socket allows a tighter fit and higher effectiveness. The pressure works directly on the faces of the nuts and bolts; weaker corners are protected. Intermediate sizes e.g. in inches (A/F, BSF, BSW) and rounded heads can be tightened or loosened using the Surface Drive.

Version:

Forgées en acier de haute qualité, chanfreinées intérieurement pour une prise rapide des têtes de boulons. Carrés femelles suivant DIN 3120. L'ouverture de douille Surface Drive permet un ajustage plus solide et une force d'action plus élevée. La pression agit directement sur les méplats des écrous et vis; les arêtes fragiles sont ménagées. Les dimensions intermédiaires, p. ex. en pouces (A/F, BSF, BSW), et les vis usées peuvent également être serrées ou desserrées à l'aide de Surface Drive.

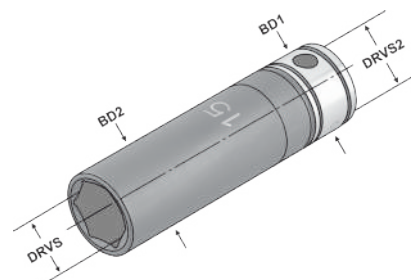

Bestell-Nr. Order no. Référence	DRVS2	DRVS	OAL	BD1	BD2
800.N.120	1/2"	12	38	22	17,8
800.N.150	1/2"	15	38	22	21,5

MESSTECHNIK
METROLOGY
MÉTROLOGIE

MESSTECHNIK

METROLOGY

MÉTROLOGIE

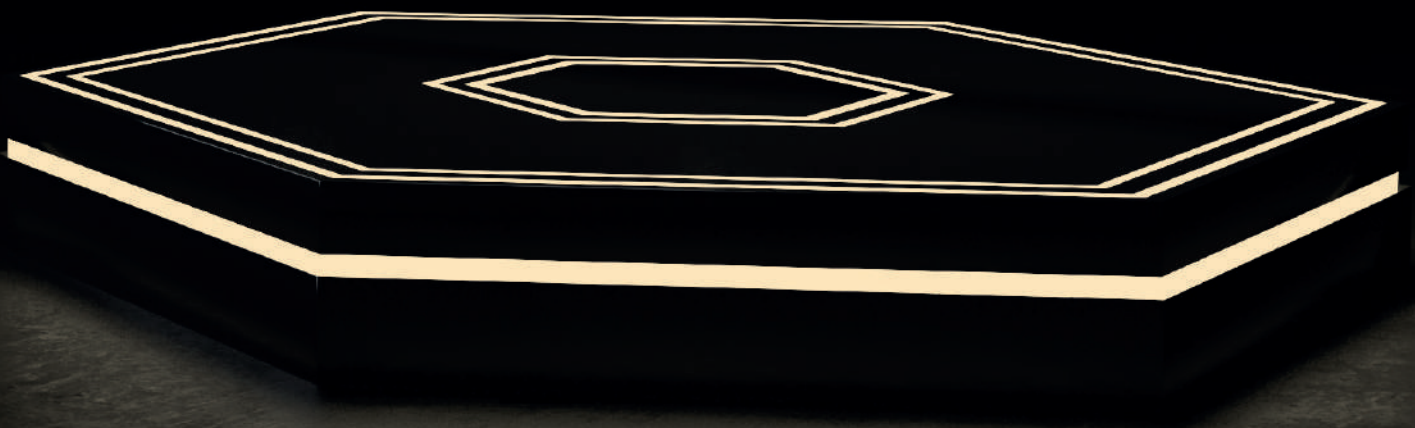



12.07	12.08	12.09	12.10
12.11	12.12	12.14	12.15
12.16	12.17	12.18	12.19
12.20	12.21	12.21	12.22
12.23	12.24	12.25	12.26
12.27	12.28	12.29	12.30
12.31	12.32	12.33	12.34
12.35	12.36	12.37	12.38

Index
Sommaire

12.39	12.40	12.40	12.41
12.42	12.43	12.45	12.46
12.47	12.48	12.49	12.51
12.52	12.53	12.54	12.55
12.56	12.57	12.57	12.58
12.59	12.61	12.62	



Messgenauigkeit nach DIN Standard
Accuracy according to DIN standard
 Précision de mesure selon la norme DIN



Mit flachem Tiefenmaß
With flat depth gauge
 Avec mesure de profondeur plate



Mit rundem Tiefenmaß
With round depth bar
 Avec mesure de profondeur ronde



Taste zur Übertragung des Messwertes über das Interface an den Computer
Key for transferring the measured value to the computer via the interface
 Bouton pour transmettre la valeur mesurée à l'ordinateur via l'interface



Staub- und strahlwassergeschützt
Dust and spray water resistant
 Protégé contre la poussière et les projections d'eau



Wasser- und ölgeschützt
Water and oil resistant
 Protégé contre l'eau et l'huile



Aus rostfreiem Stahl
Made of stainless steel
 En acier inoxydable



Messflächen aus Hartmetall / gehärtete Ausführung
Measuring face made of carbide steel
 Surfaces de mesure en métal dur / version trempée



Umschaltung von der metrischen Einheit (mm) auf die angloamerikanische Einheit (Zoll/inch).
 Drücken Sie die mm/inch Taste um die gewünschte Einheit auszuwählen.
Switching from the metric unit (mm) to the Anglo-American unit (inch/inch). Press the mm/inch button to select the desired unit.
 Conversion de la mesure métrique (mm) en mesure anglo-américaine (pouces/inch). Appuyez sur le bouton mm/inch pour sélectionner la mesure souhaitée.



Keine Begrenzung der Verfahrensgeschwindigkeit. Der Absolut-Nullpunkt bleibt erhalten, so wird z.B. falsche Ablesung durch versehentliche Nullung vermieden.
No limitation of the process speed. The absolute zero point is retained, e.g. incorrect reading due to accidental zeroing avoided.
 Pas de limite de la vitesse de la démarche.
 Le point zéro absolu est maintenu, ce qui permet par exemple d'éviter les mesures erronées à cause de la mise à zéro faite par erreur..



Alle Messmittel mit diesem Button werden mit einem Kalibrierzertifikat nach DIN EN ISO 17025 ausgeliefert.

All measuring devices with this button will be supplied with a calibration certificate according to DIN EN ISO 17025.

Tous les instruments avec ce bouton seront livrés avec le certificate de calibrage selon DIN EN ISO 17025.



Calibration Certificate

Certificate No. 9E60001
Part Number M.305.06.0 **Tool** IP67 Digital Calipers
Serial Number 1303659 **Range** (0~150)mm
Standard Name DIN862 **Resolution** 0.01mm

Visual Inspection Passed **Function Inspection** Passed

Outside Measurements

Reading	Nominal Value(mm)	Tolerance(mm) +/-	Deviation(mm)	Disposition*
1	0.00	0.02	0.00	√
2	41.30	0.02	0.00	√
3	81.50	0.02	-0.01	√
4	131.40	0.03	-0.01	√

Inside Measurements

Reading	Nominal Value(mm)	Tolerance(mm) +/-	Deviation(mm)	Disposition*
5	4.00	0.02	-0.01	√
6	25.00	0.02	-0.02	√

Depth Measurements

Reading	Nominal Value(mm)	Tolerance(mm) +/-	Deviation(mm)	Disposition*
7	0.00	0.02	0.01	√

Master information	Serial Number	DKD Number	Due Date
Gauge Block Set	0930	867,D-K-20153-01-00	2020/2/24

Humidity 50 % ± 15% **Temperature** 20 ± 0.5
Uncertainty $U=7.0\mu\text{m} + 10^{-6} \times L$ coverage factor $k=2$

Calibrator

Approved By



K Taschenmessschieber

Vernier calipers
Pieds à coulisse de poche



Ausführung:

- Geeignet zum Messen von Außen-, Innendurchmessern, Tiefen und Längen
- Edelstahl mit gehärteten Messflächen

Construction:

- *Measuring surfaces allows measurement of external diameters, internal diameters, depths and steps*
- *Stainless steel with hardened measuring faces*

Version:

- Pour mesurer les diamètres extérieurs et intérieurs, les profondeurs et les longueurs
- Acier inoxydable avec les surfaces de mesure trempées

Lieferumfang:

- Garantieschein
- Bedienungsanleitung
- Kalibrierzertifikat

Delivery:

- *Warranty card*
- *Instruction manual*
- *Calibration certificate*

Livraison avec:

- Certificat de garantie
- Mode d'emploi
- Certificat de calibrage

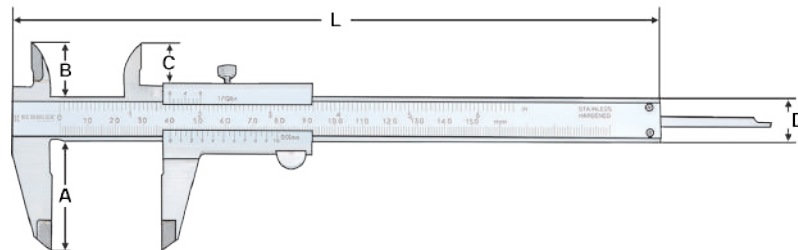
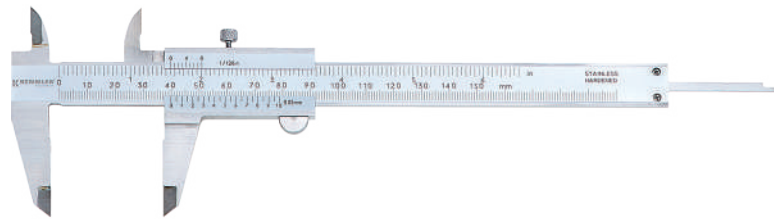

Bestell-Nr. Order no. Références	Messbereich Range Gamme de mesure	Skalenwert Scala Gamme	Genauigkeit Accuracy Précision	L	A	B	C	D
M.341.06.0	0 - 150	0,05 + 1/128"	± 0,05	235	40	21	16,5	16
M.341.08.0	0 - 200	0,05 + 1/128"	± 0,05	297	50	23,5	19	16
M.341.12.0	0 - 300	0,05 + 1/128"	± 0,05	410	64	27	22	20

Vernier calipers with thumb-lock
Pieds à coulisse de poche avec réglage du couple

DIN 862- 1988		Kal.- Zertifi- kat	mm - inch	INOX
---------------------	--	--------------------------	-----------------	------

Ausführung:

- Geeignet zum Messen von Außen-, Innendurchmessern, Tiefen und Längen
- Edelstahl mit gehärteten Messflächen

Construction:

- *Measuring surfaces allow for the measurement of external diameters, internal diameters, depths and steps*
- *Stainless steel with surface hardened measuring faces*

Version:

- Pour mesurer les diamètres extérieurs et intérieurs, les profondeurs et les longueurs
- Acier inoxydable avec les surfaces de mesure trempées

Lieferumfang:

- Garantieschein
- Bedienungsanleitung
- Kalibrierzertifikat

Delivery:

- *Warranty card*
- *Instruction manual*
- *Calibration certificate*

Livraison avec:

- Certificat de garantie
- Mode d'emploi
- Certificat de calibrage

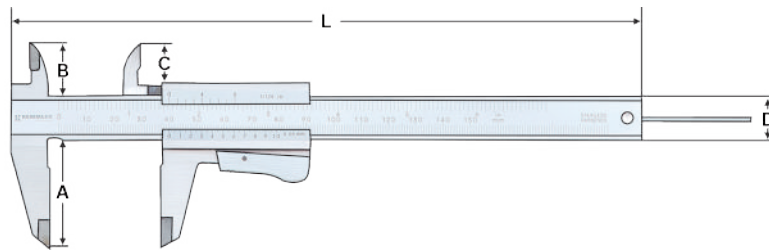

Bestell-Nr. Order no. Références	Messbereich Range Gamme de mesure	Skalenwert Scala Gamme	Genauigkeit Accuracy Précision	L	A	B	C	D
M.351.06.2*	0 - 150	0,05 + 1/128"	± 0,05	228	40	21	16,5	16
M.351.06.4	0 - 150	0,02 + 0,001"	± 0,02	228	40	21	16,5	16

*mit rundem Tiefenmaß Ø 1,8

*with round depth bar Ø 1,8

*avec la mesure de profondeur ronde Ø 1,8

K Uhrenmessschieber

Dial vernier calipers
Pieds à coulisse à montre

DIN 862- 1988		Kal.- Zertifi- kat	mm - inch	INOX
---------------------	--	--------------------------	-----------------	------

Ausführung:

- Geeignet zum Messen von Außen-, Innendurchmessern, Tiefen und Längen
- Edelstahl mit gehärteten Messflächen
- Skalenteilung: 0.02mm

Construction:

- *Measuring surfaces allow for the measurement of external diameters, internal diameters, depths and steps*
- *Stainless steel with surface hardened measuring faces*
- *Graduation: 0.02mm*

Version:

- Pour mesurer les diamètres extérieurs et intérieurs, les profondeurs et les longueurs
- Acier inoxydable avec les surfaces de mesure trempées
- Graduation: 0.02 mm

Lieferumfang:

- Garantieschein
- Bedienungsanleitung
- Kalibrierzertifikat

Delivery:

- *Warranty card*
- *Instruction manual*
- *Calibration certificate*

Livraison avec:

- Certificat de garantie
- Mode d'emploi
- Certificat de calibrage

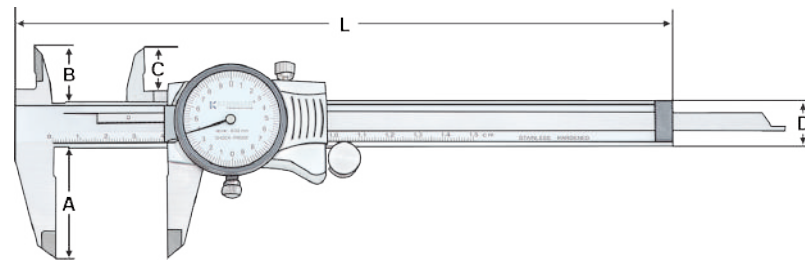
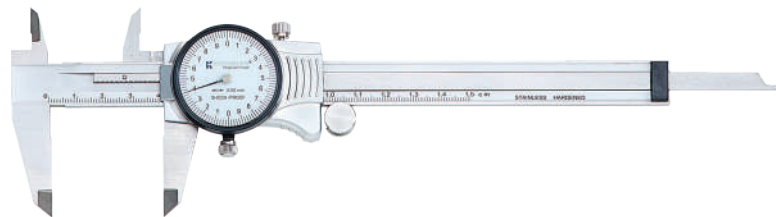

Bestell-Nr. Order no. Références	Messbereich Range Gamme de mesure	Skalenwert Scala Gamme	Genauigkeit Accuracy Précision	L	A	B	C	D
M.304.06.6	0 – 150	0,02	± 0,02	235	40	21	16,5	16

Workshop caliper with knife edge jaws and with fine adjustment

Pied à coulisse pour atelier avec les pointes couteaux et le réglage précis

DIN
862-
1988

Kal.-
Zertifi-
kat

mm
-
inch

INOX

Ausführung:

- Ablesung: 0.05mm / 1/128"
- Edelstahl
- mit Feineinstellung
- Die Messschnäbel sind abgerundet, um ein genaues Maß eines Innendurchmessers zu erhalten
- Messbereich 300 mm Innendurchmesser ab 10 mm messbar
- Messbereich ab 500mm Innendurchmesser ab 20 mm messbar

Construction:

- Graduation: 0.05mm / 1/128"
- Stainless steel
- With fine adjustment carriage to feed the slider finely
- Internal measurement jaws are rounded to provide accurate measurement of internal diameters
- Minimum internal diameter measurement capability of: 10mm for 300mm/12" range 20mm for over 500mm/20" range

Version:

- Graduation 0.05 mm/1/128"
- Acier inoxydable
- Avec le réglage précis
- Les pointes de mesure sont arrondies afin d'obtenir la mesure précise du dia. intérieur
- La gamme de mesure 300 mm dia. intérieur peut être mesuré à partir de 10 mm
- la gamme de mesure 500 mm, dia. intérieur peut être mesuré à partir de 20 mm

Lieferumfang:

- Garantieschein
- Bedienungsanleitung
- Kalibrierzertifikat

Delivery:

- Warranty card
- Instruction manual
- Calibration certificate

Livraison avec:

- Certificat de garantie
- Mode d'emploi
- Certificat de calibrage

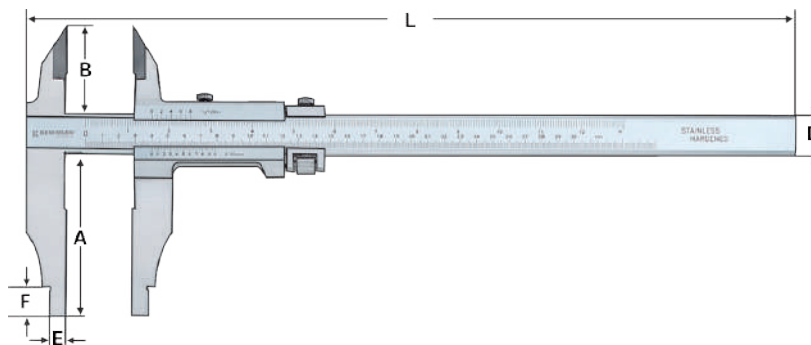
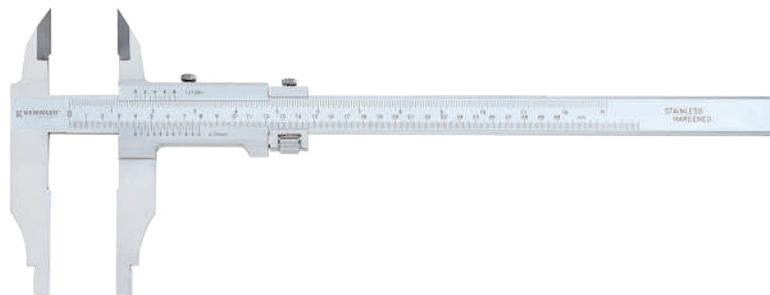

Bestell-Nr. Order no. Références	Messbereich Range Gamme de mesure	Skalenwert Scala Gamme	Genauigkeit Accuracy Précision	L	A	B	D	E	F
M.302.12.2	0 - 300	0,05 + 1/128"	± 0,08	470	100	56	25	10	18
M.302.20.2	0 - 500	0,05 + 1/128"	± 0,08	735	150	67	32	10	25
M.302.40.2	0 - 1000	0,05 + 1/128"	± 0,10	1035	150	67	32	10	25



Digital-Messschieber IP67

Digital pocket vernier calipers IP67 Pieds à coulisse à lecture numérique IP67

DIN 862- 1988		Kal.- Zertifi- kat	mm - inch	IP 67
---------------------	--	--------------------------	-----------------	-------

Ausführung:

- Auflösung: .0005" / 0.01mm
- IP 67
- extra großes LCD display
- Zoll/Metrisch
- Die Ausführung ermöglicht es den Messschieber unter rauen Werkstattbedingungen zu nutzen. Er ist wasser-, staub- und ölresistent.
- Schaltet sich automatisch ab

Lieferumfang:

- Garantieschein
- Bedienungsanleitung
- Kalibrierzertifikat
- CR2032 3,0V Batterie
- Schraubendreher

Construction:

- Resolution: .0005" / 0.01mm
- Conforms to the IP67 ratings
- Extra large LCD readout
- Inch/Metric conversion
- The design allows the caliper to be used in normal workshop conditions and is resistant to coolant, water, dust or oil
- Automatic switch off

Delivery:

- Warranty card
- Instruction manual
- Calibration certificate
- CR2032 3,0V Battery
- Screwdriver

Version:

- Résolution: .0005"/0.01 mm
- Conforme à IP67
- Affichage LCD extra large
- pouce/métrique
- La construction permet l'utilisation dans l'atelier, résistant à l'eau, à la poussière et l'huile
- S'arrête automatiquement

Livraison avec:

- Certificat de garantie
- Mode d'emploi
- Certificat de calibrage
- Pile CR2032 3,0V
- Tournevis

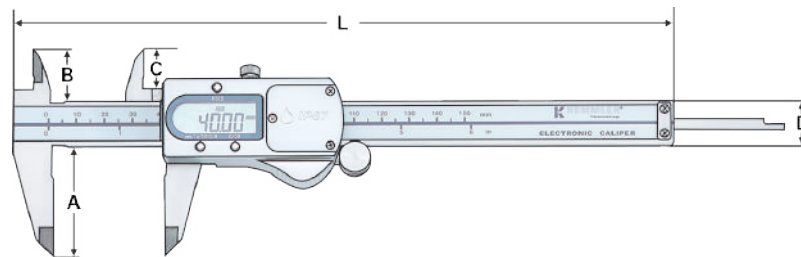
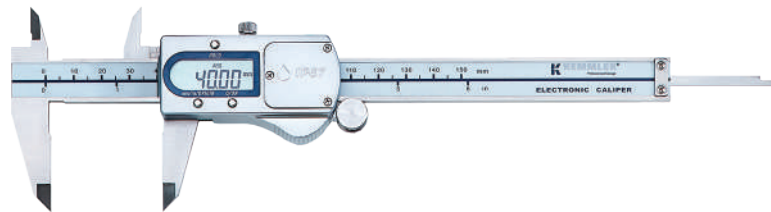

Bestell-Nr. Order no. Références	Messbereich Range Gamme de mesure	Skalenswert Scala Gamme	Genauigkeit Accuracy Précision	L	A	B	C	D
M.305.06.2	0 - 150	0,01	± 0,02	236	40	21	16,5	16
M.305.08.2	0 - 200	0,01	± 0,03	286	50	24	19,5	16
M.305.12.2	0 - 300	0,01	± 0,03	400	60	25	20,5	16



Digital pocket vernier calipers Pieds à coulisse à lecture numérique



Ausführung:

- Auflösung: .0005" / 0.01mm
- Der Messschieber ist messbereit, sobald er eingeschaltet ist und die Anzeige im Display erscheint
- Es ist nicht nötig vor jedem Gebrauch den Messschieber wieder auf Null zu setzen, da die Stellung beibehalten wird, auch wenn der Messschieber ausgeschaltet ist
- Zoll/Metrisch

Lieferumfang:

- Garantieschein
- Bedienungsanleitung
- Kalibrierzertifikat
- CR2032 3,0V Batterie

Construction:

- Resolution: .0005" / 0.01mm
- The caliper will be ready for measurements as soon as it is switched on with the LCD screen displaying the actual slider position
- There is no need to set the zero position each time the caliper is used as the origin setting is retained even when the caliper is switched off
- Inch/Metric conversion

Delivery:

- Warranty card
- Instruction manual
- Calibration certificate
- CR2032 3,0V Battery

Version:

- Résolution: .0005" / 0.01 mm
- Le pied à coulisse est prêt dès la mise en marche et l'affichage sur l'écran
- Remise à zéro n'est pas nécessaire avant chaque utilisation car la position est gardée malgré la désactivation
- pouce/métrique

Livraison avec:

- Certificat de garantie
- Mode d'emploi
- Certificat de calibrage
- Pile CR2032 3,0V

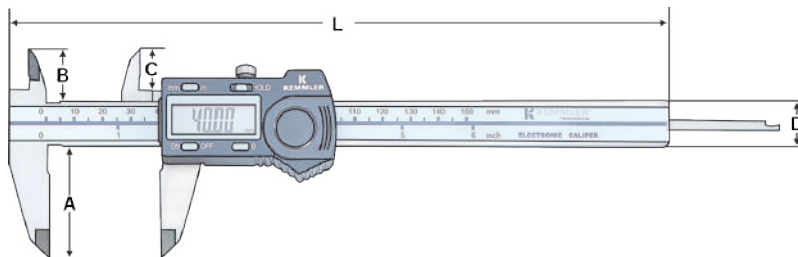
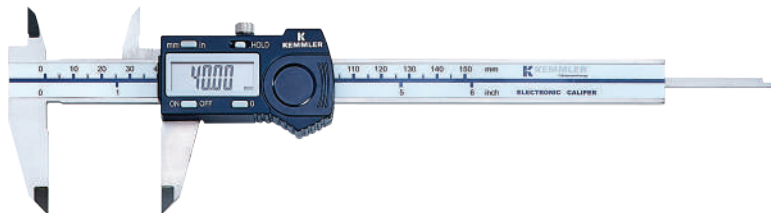

Bestell-Nr. Order no. Références	Messbereich Range Gamme de mesure	Skalenwert Scala Gamme	Genauigkeit Accuracy Précision	L	A	B	C	D
M.307.06.4	0 - 150	0,01	± 0,02	236	40	21	16,5	16
M.307.08.4	0 - 200	0,01	± 0,03	286	50	24	19,5	16
M.307.12.4	0 - 300	0,01	± 0,03	400	60	25	20,5	16



K Digital-Messschieber ABS

Digital pocket vernier calipers ABS Pieds à coulisse à lecture numérique ABS



Ausführung:

- Auflösung: .0005" / 0.01mm
- Der Messschieber ist messbereit, sobald er eingeschaltet ist und die Anzeige im Display erscheint
- Es ist nicht nötig vor jedem Gebrauch den Messschieber wieder auf Null zu setzen, da die Stellung beibehalten wird, auch wenn der Messschieber ausgeschaltet ist
- Zoll/Metrisch
- Mit Datenausgang

Lieferumfang:

- Garantieschein
- Bedienungsanleitung
- Kalibrierzertifikat
- CR2032 3,0V Batterie

Construction:

- Resolution: .0005" / 0.01mm
- The caliper will be ready for measurements as soon as it is switched on with the LCD screen displaying the actual slider position
- There is no need to set the zero position each time the caliper is used as the origin setting is retained even when the caliper is switched off
- Inch/Metric conversion
- Data output

Delivery:

- Warranty card
- Instruction manual
- Calibration certificate
- CR2032 3,0V Battery

Version:

- Résolution: .0005" / 0.01 mm
- Le pied à coulisse est prêt dès la mise en marche et l'affichage sur l'écran
- Remise à zero n'est pas nécessaire avant chaque utilisation car la position est gardée malgré la désactivation
- Pouce/métrique
- Avec la sortie de données

Livraison avec:

- Certificat de garantie
- Mode d'emploi
- Certificat de calibrage
- Pile CR2032 3,0V

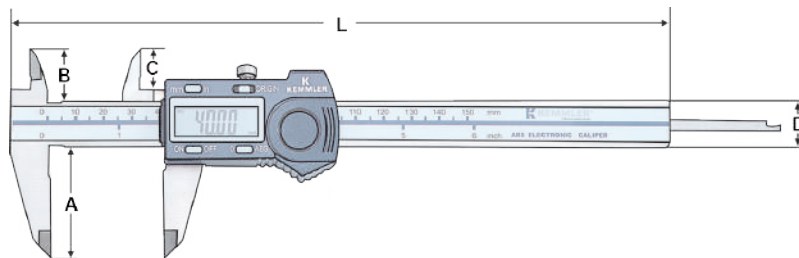

Bestell-Nr. Order no. Références	Messbereich Range Gamme de mesure	Skalenwert Scala Gamme	Genauigkeit Accuracy Précision	L	A	B	C	D
M.307.56.2	0 – 150	0,01	± 0,02	236	40	21	16,5	16
M.307.58.2	0 – 200	0,01	± 0,03	286	50	24	19,5	16
M.307.62.2	0 – 300	0,01	± 0,03	400	60	25	20,5	16

12

Zubehör | Accessories | Accessoires

Batterie 3 V | CR2032
Battery 3 V | CR2032
Pile 3 V | CR2032

M.CR2032

Datenverbindungskabel
Data Connection Cable
Câble de connexion de données

M.900.05.4 | M.900.05.5 | M.901.00.3 | M.901.00.4



Digital caliper heavy duty ABS

Pied à coulisse d'atelier numérique ABS



Ausführung:

- Auflösung: .0005" / 0.01mm
- Mit Feinverstellung um eine exaktes Bewegen des Schiebers zu ermöglichen
- Die Messschnäbel sind abgerundet, um ein genaues Maß eines Innendurchmessers zu erhalten
- Innendurchmesser ab 20 mm messbar
- Zoll/Metrisch
- Nullstellung in jeder Position
- Mit Datenausgang

Construction:

- Resolution: .0005" / 0.01mm
- Designed with fine adjustment to allow precise movement of the slider
- Internal measurement jaws are rounded to provide accurate measurement of internal diameters
- Minimum internal diameter measurement capability of 20mm
- Inch/Metric conversion
- Zero setting at any position
- Data output

Version:

- Résolution: .0005" / 0.01 mm
- Avec le réglage fin qui permet le mouvement exact du poussoir
- Les pointes de mesure sont arrondies afin d'obtenir la mesure précise du dia. intérieur
- Dia. intérieur peut être mesuré à partir de 20 mm
- Pouce/métrique
- Remise à zero à chaque position
- Avec sortie de données

Lieferumfang:

- Garantieschein
- Bedienungsanleitung
- Kalibrierzertifikat
- CR2032 3,0V Batterie

Delivery:

- Warranty card
- Instruction manual
- Calibration certificate
- CR2032 3,0V Battery

Livraison avec:

- Certificat de garantie
- Mode d'emploi
- Certificat de calibrage
- Pile CR2032 3,0V

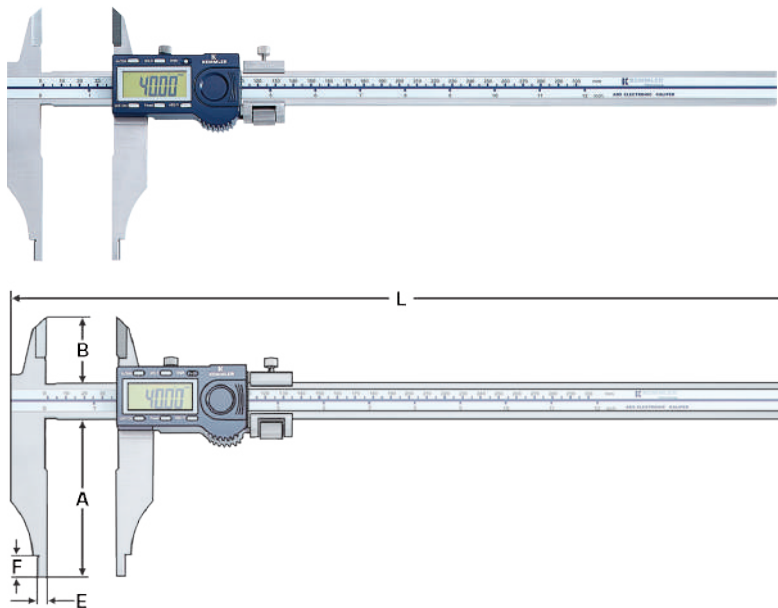

Bestell-Nr. Order no. Références	Messbereich Range Gamme de mesure	Skalenwert Scala Gamme	Genauigkeit Accuracy Précision	L	A	B	D	E	F
M.315.12.8	0 - 300	0,01	± 0,04	470	90	56	25	10	18
M.315.20.8	0 - 500	0,01	± 0,05	680	150	56	25	10	25
M.315.32.8	0 - 800	0,01	± 0,07	1030	150	67	32	10	25
M.315.40.8	0 - 1000	0,01	± 0,07	1230	150	67	32	10	25

Zubehör | Accessories | Accessoires

Batterie | Battery | Pile

M.CR2032

Datenverbindung | Data Connection | Connexion de données

M.900.05.4 | M.900.05.5 | M.901.00.3 | M.901.00.4



K Digital Messschieber für Außennuten ABS

Digital vernier calipers for outside grooves ABS
 Pieds à coulisse numérique pour rainures extérieures ABS

DIN
862-
1988

Kal.-
Zertifi-
kat

mm
-
inch

Absolut
System

Ausführung:

- Auflösung: .0005" / 0.01 mm
- Misst Außennuten und Aussparungen
- Zoll/Metrisch
- Nullstellung bei jeder Position möglich
- Mit Datenausgang

Lieferumfang:

- Garantieschein
- Bedienungsanleitung
- Kalibrierzertifikat
- CR2032 3,0V Batterie

Construction:

- Resolution: .0005" / 0.01 mm
- Measures external grooves and recessed hub dimensions
- Inch/Metric conversion
- Zero-setting at any position for incremental measurement
- Data output

Delivery:

- Warranty card
- Instruction manual
- Calibration certificate
- CR2032 3,0V Battery

Version:

- Résolution: .0005" / 0.01 mm
- Pour pouvoir mesurer les rainures extérieures et les encoches
- Pouce/métrique
- Remise à zero est possible à chaque position
- Avec la sortie de données

Livraison avec:

- Certificat de garantie
- Mode d'emploi
- Certificat de calibrage
- Pile CR2032 3,0V

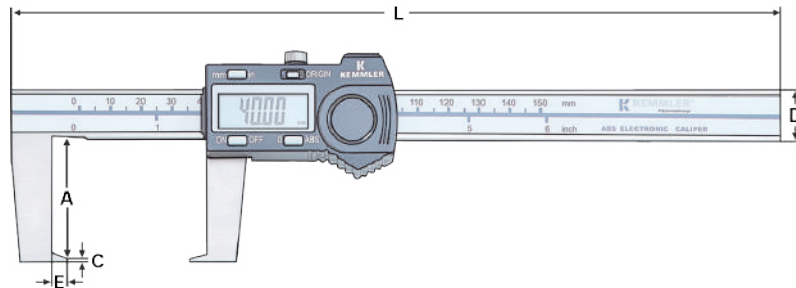

Bestell-Nr. Order no. Références	Messbereich Range Gamme de mesure	Skalenwert Scala Gamme	Genauigkeit Accuracy Précision	L	A	B	C	D	E
M.309.06.5	0 – 150	0,01 / .0005"	± 0,03	250	40	15	1	16	5
M.309.08.5	0 – 200	0,01 / .0005"	± 0,04	300	50	19	1,5	16	7
M.309.12.5	0 – 300	0,01 / .0005"	± 0,04	405	60	21	2	16	10

Zubehör | Accessories | Accessoires

Batterie | Battery | Pile
 M.CR2032

Datenverbindung | Data Connection | Connexion de données
 M.900.05.4 | M.900.05.5 | M.901.00.3 | M.901.00.4



Digital vernier calipers for inside grooves ABS Pieds à coulisse numérique pour rainures intérieures ABS

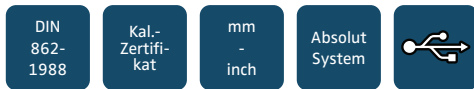

Ausführung:

- Auflösung: .0005" / 0.01mm
- misst Innennuten, Bohrungen usw.
- Zoll/Metrisch
- Nullstellung bei jeder Position möglich
- Mit Datenausgang

Construction:

- Resolution: .0005" / 0.01mm
- Measures internal grooves, bores and other details
- Inch/Metric conversion
- Zero-setting at any position for incremental measurement
- Data output

Version:

- Résolution: .0005" / 0.01 mm
- Pour mesurer les rainures intérieures, alésages etc.
- Pouce/métrique
- Remise à zero possible à chaque position
- Avec la sortie de données

Lieferumfang:

- Garantieschein
- Bedienungsanleitung
- Kalibrierzertifikat
- CR2032 3,0V Batterie

Delivery:

- Warranty card
- Instruction manual
- Calibration certificate
- CR2032 3,0V Battery

Livraison avec:

- Certificat de garantie
- Mode d'emploi
- Certificat de calibrage
- Pile CR2032 3,0V

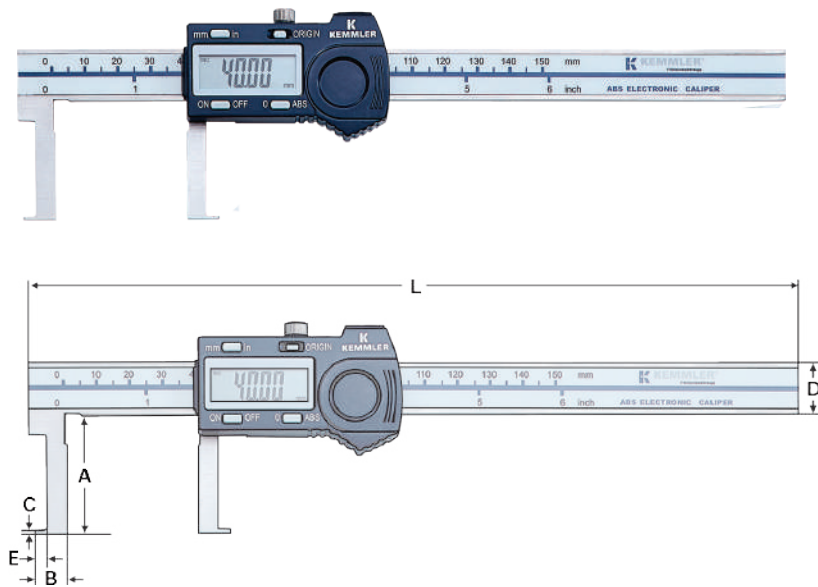

Bestell-Nr. Order no. Références	Messbereich Range Gamme de mesure	Skalenwert Scala Gamme	Genauigkeit Accuracy Précision	L	A	B	C	D	E
M.309.06.6	20 - 150	0,01 / .0005"	± 0,03	235	36	10	1	16	10
M.309.08.6	25 - 200	0,01 / .0005"	± 0,04	287	46	12,5	1,5	16	12,5
M.309.12.6	30 - 300	0,01 / .0005"	± 0,04	390	48	15	1,5	16	15

Zubehör | Accessories | Accessoires

Batterie Battery Pile	Datenverbindung Data Connection Connexion de données
M.CR2032	M.900.05.4 M.900.05.5 M.901.00.3 M.901.00.4



K Tiefenmessschieber

Depth vernier calipers
Pied à coulisse de profondeur

DIN 862- 1988	Kal.- Zertifi- kat	mm	INOX	
---------------------	--------------------------	----	------	---

Ausführung:

- Auflösung: 0.05mm
- Messflächen sind feingeschliffen
- Gehärteter Edelstahl

Construction:

- Resolution: 0.05mm
- Measuring surfaces are precision ground for accuracy
- Stainless steel, hardened

Version:

- Resolution: 0.05 mm
- Surfaces de mesure rectifiées
- Acier inoxydable trempée

Lieferumfang:

- Garantieschein
- Bedienungsanleitung
- Kalibrierzertifikat

Delivery:

- Warranty card
- Instruction manual
- Calibration certificate

Livraison avec:

- Certificat de garantie
- Mode d'emploi
- Certificat de calibrage

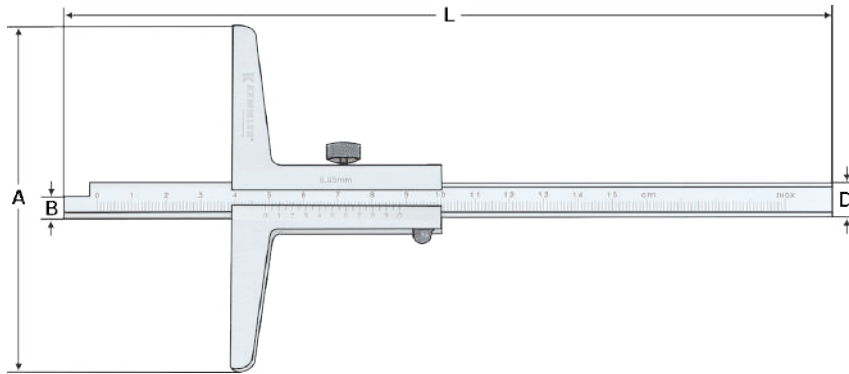
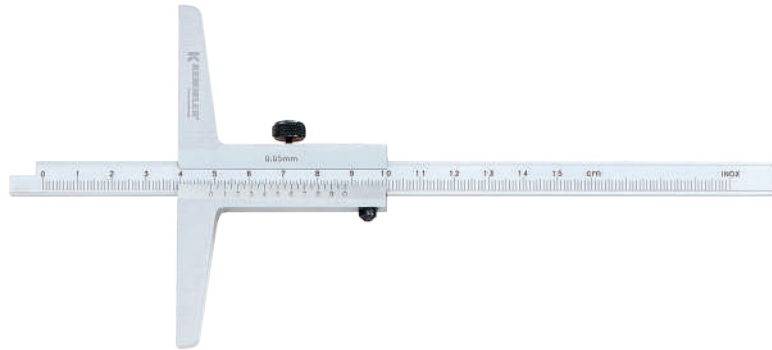

Bestell-Nr. Order no. Références	Messbereich Range Gamme de mesure	Skalenwert Scala Gamme	Genauigkeit Accuracy Précision	L	A	B	D
M.321.06.0	0 - 150	0,05	± 0,05	250	100	5	10
M.321.08.0	0 - 200	0,05	± 0,05	300	100	5	10
M.321.12.0	0 - 300	0,05	± 0,05	400	100	5	10

Digital depth vernier calipers

Pied à coulisse de profondeur numérique ABS



Ausführung:

- Auflösung: 0.01 mm / .0005"
- Messflächen sind feingeschliffen
- Gehärteter Edelstahl
- Mit Datenausgang

Construction:

- Resolution: 0.01 mm / .0005"
- Measuring surfaces are precision ground for accuracy
- Stainless steel, hardened
- Data output

Version:

- Resolution: 0.01 mm / .0005"
- Surfaces de mesure rectifiées
- Acier inoxydable trempée
- Avec sortie de données

Lieferumfang:

- Garantieschein
- Bedienungsanleitung
- Kalibrierzertifikat
- CR2032 3,0V Batterie

Delivery:

- Warranty card
- Instruction manual
- Calibration certificate
- CR2032 3,0V Battery

Livraison avec:

- Certificat de garantie
- Mode d'emploi
- Certificat de calibrage
- Pile CR2032 3,0V

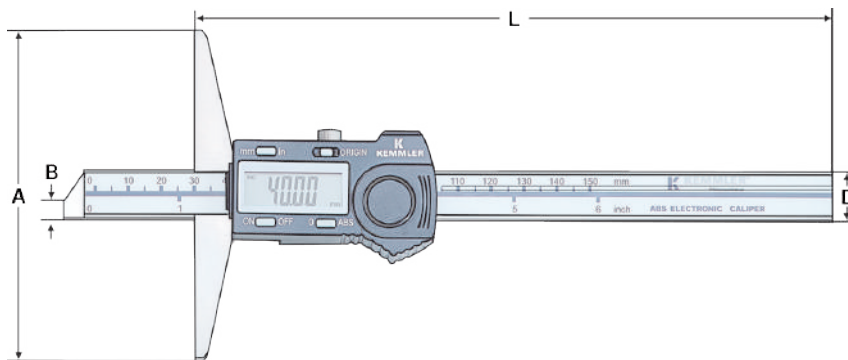
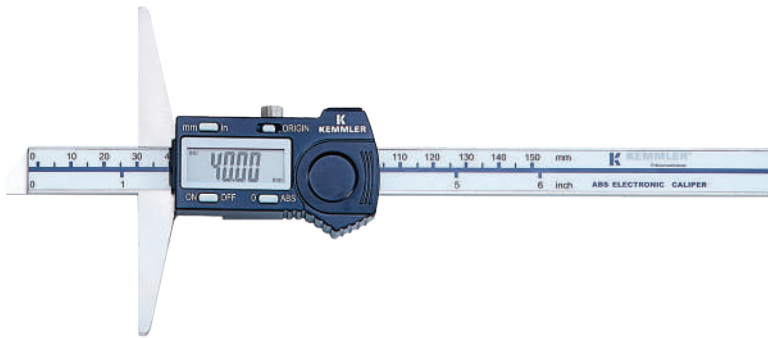

Bestell-Nr. Order no. Références	Messbereich Range Gamme de mesure	Skalenwert Scala Gamme	Genauigkeit Accuracy Précision	L	A	B	D
M.327.06.7	0 – 150	0,01	± 0,02	230	100	6	14,5
M.327.08.7	0 – 200	0,01	± 0,03	280	100	6	14,5
M.327.12.7	0 – 300	0,01	± 0,04	380	100	6	14,5

Zubehör | Accessories | Accessoires

Batterie | Battery | Pile

M.CR2032

Datenverbindung | Data Connection | connexion de données

M.900.05.4 | M.900.05.5 | M.901.00.3 | M.901.00.4





Digital-Tiefenmessschieber

Digital depth gauge
Jauges de profondeur numérique

Ausführung:

- Auflösung: .0005" / 0.01 mm
- die Originaleinstellung bleibt erhalten, solange die Batterie voll ist
- Zoll/Metrisch
- sphärischer Messeinsatz

Construction:

- Resolution: .0005" / 0.01 mm
- The origin point is retained throughout the life of the battery
- Inch/Metric conversion
- Spherical end anvil

Version:

- Resolution: .0005" / 0.01 mm
- Réglage original est gardé à moins que la pile soit pleine
- Pouce / métrique
- Embout de mesure sphérique

Lieferumfang:

- Garantieschein
- Bedienungsanleitung
- Kalibrierzertifikat
- LR44 1,5V Batterie

Delivery:

- Warranty card
- Instruction manual
- Calibration certificate
- LR44 1,5V Battery

Livraison avec:

- Certificat de garantie
- Mode d'emploi
- Certificat de calibrage
- Pile CR2032 3,0V

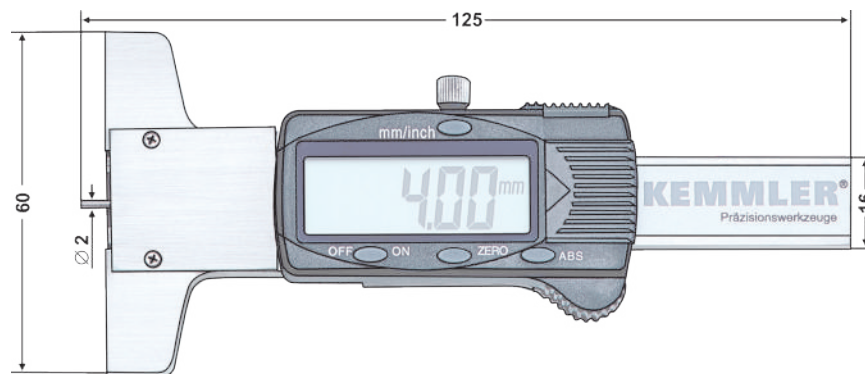

Bestell-Nr.
Order no.
Références

M.321.01.0

Messbereich
Range
Gamme de mesure

0 - 30

Skalenwert
Scala
Gamme

0,01

Genauigkeit
Accuracy
Précision

± 0,03

12



12.58

12.19

KEMMLER

K24



Bestell-Nr. Order no. Références	Abmessung Size Dimension
M.M.SET10	Bestehend aus: <i>Consisting of:</i> Composé de:
M.402.30.0	Präzisions Messuhr analog Dial indicator analogue Comparateur de précision analogique Ø 58 0,01 30 mm
M.402.10.0	Präzisions Messuhr analog Dial indicator analogue Comparateur de précision analogique Ø 58 0,01 10 mm
M.101.01.0	Bügelmessschraube analog Micrometer analogue Micromètre extérieur analogique 0 - 25 0,01 mm
M.105.01.4	Bügelmessschraube digital Micrometer digital Micromètre extérieur numérique 0 - 25 0,001
M.341.06.0	Messschieber analog Vernier caliper analogue Pied à coulisse analogique 0-150mm 1/128" 0,05mm
M.307.56.2	Digitaler Messschieber Digital Caliper Pied à coulisse numérique 0-150mm 0,01 mm
M.602.02.1	Präzisions Magnet Messstativ Precision Magnetic base Base magnétique de précision 350mm Ø 3/8" Ø8mm
M.501.08.2	Fühlhebelmessgerät Dial test indicator Indicateur à levier Ø 32 0,01 0,8mm

K Bügelmessschrauben

External micrometer Micromètres extérieurs



Ausführung:

- Ablesung: 0.01mm
- Ebenheit: 0.6my
- Hartmetallmessflächen
- Mit Ratsche

Construction:

- Graduation: 0.01mm
- Flatness: 0.6my
- Carbide tipped measuring faces
- Ratchet Stop

Version:

- Graduation: 0.01mm
- Planéité: 0.6 my
- Surfaces de mesure en carbure monobloc
- Avec cliquet

Lieferumfang:

- Haken-Schlüssel, ab 25 mm Messbereich mit Einstellmaß
- Garantieschein
- Bedienungsanleitung
- Kalibrierzertifikat

Delivery:

- S-wrench, Standard (over 25mm range)
- Warranty card
- Instruction manual
- Calibration certificate

Livraison avec:

- Clé à ergot, gamme de mesure dès 25 mm avec pignes de réglage
- Certificat de garantie
- Mode d'emploi
- Certificat de calibrage

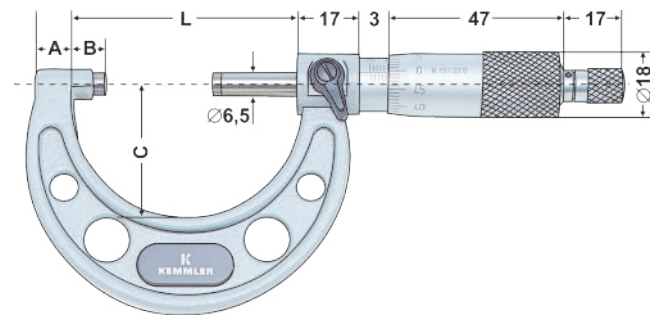

Bestell-Nr. Order no. Références	Messbereich Range Gamme de mesure	Skalenwert Scala Gamme	Genauigkeit Accuracy Précision	A	B	C	L
M.101.01.0	0 - 25	0,01	0,004	9	3	28	32
M.101.02.0	25 - 50	0,01	0,004	14	3	38	57
M.101.03.0	50 - 75	0,01	0,005	14,5	3	49	82
M.101.04.0	75 - 100	0,01	0,005	15	3	60	107
M.101.05.0	100 - 125	0,01	0,006	16,5	3	73	133
M.101.06.0	125 - 150	0,01	0,006	16,5	3	85	158
M.101.07.0	150 - 175	0,01	0,007	19,4	3	104	183
M.101.08.0	175 - 200	0,01	0,007	19,4	3	117	209
M.101.09.0	200 - 225	0,01	0,008	19,4	3	130	234
M.101.10.0	225 - 250	0,01	0,008	19,4	3	142	260
M.101.11.0	250 - 275	0,01	0,009	19,4	3	155	285
M.101.12.0	275 - 300	0,01	0,009	19,4	3	168	310



12

Bestell-Nr. Order no. Références	Messbereich Range Gamme de mesure	Skalenwert Scala Gamme	
M.101.64.8	0 - 100	0,01	Satz mit 4 St. Set with 4 pcs. Jeu avec 4 pc.
M.101.66.8	0 - 150	0,01	Satz mit 6 St. Set with 6 pcs. Jeu avec 6 pc.
M.101.72.8	0 - 300	0,01	Satz mit 12 St. Set with 12 pcs. Jeu avec 12 pc.

Prec. digital micrometers ABS IP65

Micromètres extérieurs numériques ABS IP65



Ausführung:

- Auflösung: .00005"/0.001mm
- Anzeige: 0.01mm
- Ebenheit: 0.3µm
- Spritzwasserfest IP 65
- Umstellung Zoll/Metrisch
- Mit Ratsche
- Hartmetallmessflächen

Construction:

- Resolution: .00005"/0.001mm
- Scale: 0.01mm
- Flatness: 0.3µm
- Protection level IP65
- Inch/Metric conversion
- Ratchet Stop
- Carbide tipped measuring faces

Version:

- Resolution: .00005"/0.001 mm
- Affichage: 0.01 mm
- planéité: 0.3µm
- Résistant aux projections d'eau IP65
- pouce / métrique
- Avec cliquet
- Surfaces de mesure en carbure monobloc

Lieferumfang:

- Haken-Schlüssel, ab 25 mm Messbereich mit Einstellmaß
- Garantieschein
- Bedienungsanleitung
- Kalibrierzertifikat
- CR2032 3,0V Batterie

Delivery:

- S-wrench, Standard (over 25mm range)
- Warranty card
- Instruction manual
- Calibration certificate
- CR2032 3,0V Battery

Livraison avec:

- Clé à ergot, gamme de mesure dès 25 mm avec pignes de réglage
- Certificat de garantie
- Mode d'emploi
- Certificat de calibrage
- Pile CR2032 3,0V

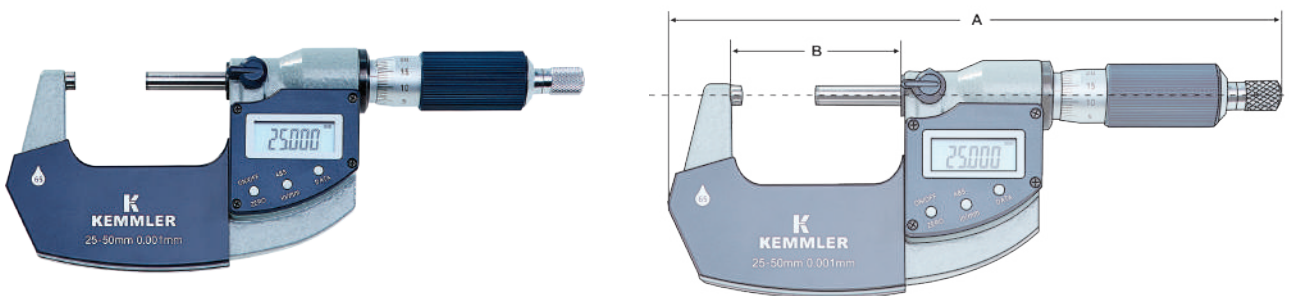

Bestell-Nr. Order no. Références	Messbereich Range Gamme de mesure	Skalenwert Scala Gamme	Genauigkeit Accuracy Précision	A	B
M.105.01.4	0 - 25	0,001	± 0,002	168	30
M.105.02.4	25 - 50	0,001	± 0,002	198	55
M.105.03.4	50 - 75	0,001	± 0,003	226	81
M.105.04.4	75 - 100	0,001	± 0,003	256	106
M.105.05.4	100 - 125	0,001	± 0,003	286	131
M.105.06.4	125 - 150	0,001	± 0,003	316	156

Zubehör | Accessories | Accessoires

Datenverbindungskabel | Data Connection Cable | Câble de connexion de données

M.900.05.4 | M.900.05.5 | M.901.00.3 | M.901.00.4



K Innenmessschraube IP65 ABS

Inside micrometer IP65 ABS Micromètre d'intérieur IP65 ABS



Ausführung:

- Auflösung: .00005" / 0.001 mm
- für das Messen von speziellen Innenmerkmalen
- Hartmetallmessflächen
- matt verchromt
- 5-30 mm und 25-50 mm werden mit Einstellringen geliefert
- Ratsche

Construction:

- Resolution: .00005" / 0.001mm
- Designed for the measurement of intricate internal characteristics
- Carbide tipped measuring surfaces
- Dull chromed finished
- 5-30mm and 25-50mm range are supplied with setting rings
- Ratchet stop

Version:

- Resolution: .00005"/0.001 mm
- Pour mesurer les caractéristiques spéciales intérieures
- Surfaces de mesure en carbure monobloc
- Chromé mat
- 5-30 mm et 25-50 mm sont livré avec bagues de réglage
- Avec cliquet

Lieferumfang:

- Haken-Schlüssel
- Einstellringe
- Garantieschein
- Bedienungsanleitung
- Kalibrierzertifikat
- LR44 1,5V Batterie

Delivery:

- S-wrench
- Setting rings
- Warranty card
- Instruction manual
- Calibration certificate
- LR44 1,5V Battery

Livraison avec:

- Clé à ergot
- Bagues de réglage
- Certificat de garantie
- Mode d'emploi
- Certificat de calibrage
- Pile LR44 1,5 V

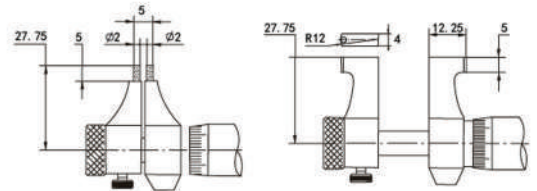
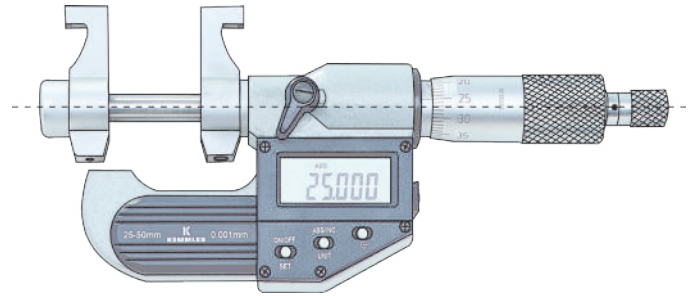

Bestell-Nr. Order no. Références	Messbereich Range Gamme de mesure	Skalenwert Scala Gamme	Genauigkeit Accuracy Précision
M.207.01.0	5 - 30	0,001	± 0,003
M.207.02.0	25 - 50	0,001	± 0,003
M.207.03.0	50 - 75	0,001	± 0,004
M.207.04.0	75 - 100	0,001	± 0,004
M.207.05.0	100 - 125	0,001	± 0,005
M.207.06.0	125 - 150	0,001	± 0,005
M.207.07.0	150 - 175	0,001	± 0,005
M.207.08.0	175 - 200	0,001	± 0,005

12

Zubehör | Accessories | Accessoires

Batterie | Battery | Pile
M.LR44

Datenverbindung | Data Connection | connexion de données
M.900.10.0



Blade Micrometer IP65 ABS

Micromètre pour mesurer les rainures IP65 ABS



Ausführung:

- Auflösung: .00005" / 0.001mm
- Für das Messen des Nutdurchmessers bei Wellen, Keilnuten usw.
- Automatisches AN/AUS für lange Lebensdauer der Batterie
- Meßergebnis sofort nach dem Einschalten ablesbar
- Umstellung Zoll/Metrisch
- Hartmetall Messflächen
- Nichtdrehende Spindel
- Ratsche

Construction:

- Resolution: .00005" / 0.001mm
- For measuring the groove diameter of shafts, keyways, and other hard to reach portions
- Automatic On/Off to maximize battery life
- Upon switching on the display will read the actual absolute measuring position
- Inch/Metric conversion
- Carbide tipped measuring faces
- Non-rotating spindle
- Ratchet stop

Version:

- Resolution: .00005" / 0.001 mm
- Pour mesurer le diamètre des rainures sur les arbres, les rainures de clavette, etc.
- Marche / arrêt automatique pour la durée de vie de la pile plus longue
- Résultat de mesure lisible dès la mise en marche
- Pouce / métrique
- Surfaces de mesure en carbure monobloc
- Broche non-tournante
- Avec cliquet

Lieferumfang:

- Haken-Schlüssel
- Ab 25 mm Messbereich mit Einstellmaß
- Garantieschein
- Bedienungsanleitung
- Kalibrierzertifikat
- LR44 1,5V Batterie

Delivery:

- S-wrench
- Standard (over 25mm range)
- Warranty card
- Instruction manual
- Calibration certificate
- LR44 1,5V Battery

Livraison avec:

- Clé à ergot
- Gamme de mesure dès 25 mm avec pignes de réglage
- Certificat de garantie
- Mode d'emploi
- Certificat de calibrage
- pile LR44 1,5 V

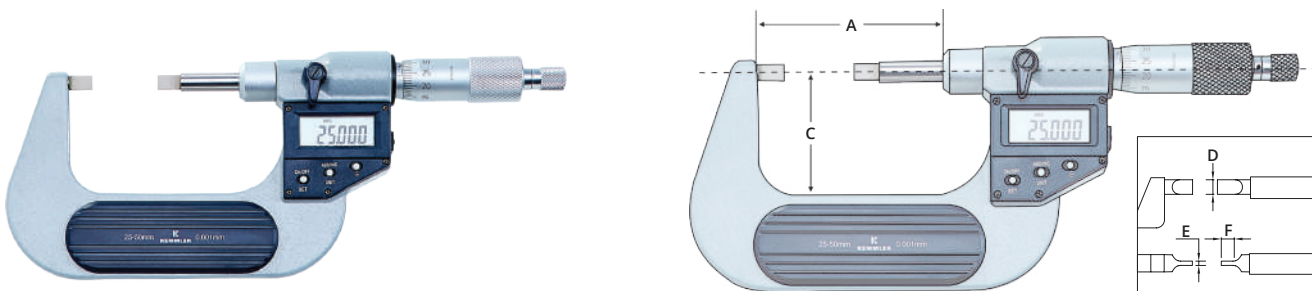

Bestell-Nr. Order no. Références	Messbereich Range Gamme de mesure	Skalenwert Scala Gamme	Genauigkeit Accuracy Précision	A	C	D	E	F
M.117.01.0	0 - 25	0,001	± 0,002	57	32	6	0,75	6,5
M.117.02.0	25 - 50	0,001	± 0,002	82	44,5	6	0,75	6,5
M.117.03.0	50 - 75	0,001	± 0,003	107	57	6	0,75	6,5
M.117.04.0	75 - 100	0,001	± 0,003	132,6	69,5	6	0,75	6,5

Zubehör | Accessories | Accessoires

Batterie | Battery | Pile

M.LR44

Datenverbindung | Data Connection | Connexion de données

M.900.10.0



K Halter für Bügelmessschrauben

Micrometer stand
Support pour micromètre

Ausführung:

- Halter für alle gängigen Bügelmessschrauben

Construction:

- *These stands are designed to allow bench top use with hand micrometers*

Version:

- Support pour tous micromètres standards



Bestell-Nr.
Order no.
Références

M.109.02.1

Material
Material
Matériel

Gusseisen | Cast iron | Fonte

2 +3 point internal micrometer | digital | IP65 | 3-12mm

Micromètre d'intérieur numérique à 2+3 touches | digital | IP65 | 3-12mm

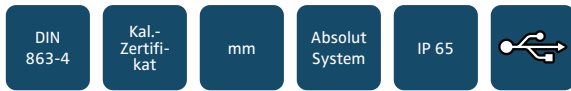

Ausführung:

- Ablesung: 0.001mm
- Geeignet für Sacklochbohrungen
- Hartmetallmessflächen
- Ableseile mattverchromt
- Gefühlsratsche

Construction:

- Graduation: 0.001mm
- Measuring contact points are designed to allow measurements near to the bottom of blind holes
- reading parts dull chromed
- Measuring surfaces are carbide
- Ratchet stop

Version:

- Graduation: 0.001 mm
- Pour mesurer les alésages borgnes
- Surfaces de mesure en carbure monobloc
- Parties de lecture chromées mates
- Avec cliquet

Lieferumfang:

- Einstellringe
- Verlängerung > 6mm
- Garantieschein
- Bedienungsanleitung
- Kalibrierzertifikat
- LR44 1,5V Batterie

Delivery:

- Setting rings
- Extension rod >6mm
- Warranty card
- Instruction manual
- Calibration certificate
- LR44 1,5V Battery

Livraison avec:

- Bagues de réglage
- Rallonge >6mm
- Certificat de garantie
- Mode d'emploi
- Certificat de calibrage
- Pile LR44 1,5 V

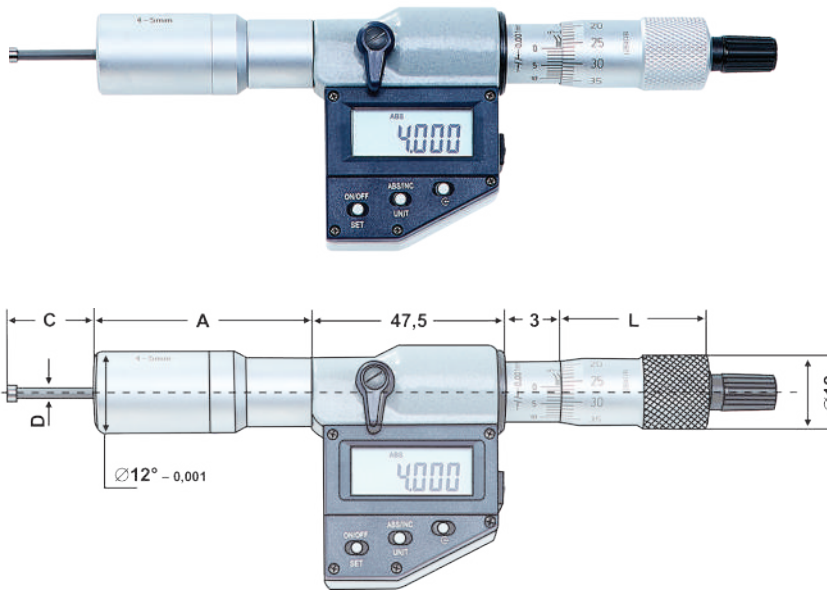

Bestell-Nr. Order no. Références	Messbereich Range Gamme de mesure	Skalenwert Scala Gamme	Genauigkeit Accuracy Précision	Einstellung Setting ring Bague de réglage	Verlängerung Extension rod Rallonge	L	A
M.208.08.0	3 - 4	0,001	0,004	4	-	22,5	-
M.208.09.0	4 - 5	0,001	0,004	5	-	22,5	-
M.208.10.0	5 - 6	0,001	0,004	6	-	22,5	-
M.208.11.0	6 - 8	0,001	0,004	6	100	53,5	100
M.208.12.0	8 - 9	0,001	0,004	8	100	53,5	100
M.208.13.0	10 - 12	0,001	0,004	10	100	53,5	100

Zubehör | Accessories | Accessoires

Batterie Battery Pile M.LR44	Datenverbindung Data Connection connexion de données M.900.10.0
-------------------------------------	--



K 3 Punkt Innenmessgerät | digital | IP65 | 12-100mm

3 point internal micrometer | digital | IP65 | 12-100mm

Micromètre d'intérieur numérique à 3 touches | digital | IP65 | 12-100mm

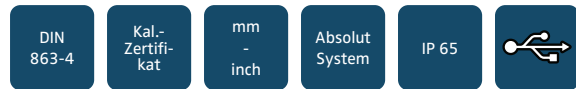

Ausführung:

- Ablesung: 0.001mm
- Geeignet für Sacklochbohrungen
- Hartmetallmessflächen
- Ableseteile mattverchromt
- Gefühlsratsche

Construction:

- Graduation: 0.001mm
- Measuring contact points are designed to allow measurements near to the bottom of blind holes
- Measuring surfaces are carbide
- reading parts brushed chromium-plated
- Ratchet stop

Version:

- Graduation: 0.001 mm
- Pour mesurer les alésages borgnes
- Surfaces de mesure en carbure monobloc
- Parties de lecture chromées mates
- Avec cliquet

Lieferumfang:

- Einstellringe
- Verlängerung
- Garantieschein
- Bedienungsanleitung
- Kalibrierzertifikat
- LR44 1,5V Batterie

Delivery:

- Setting rings
- Extension rod
- Warranty card
- Instruction manual
- Calibration certificate
- LR44 1,5V Battery

Livraison avec:

- Bagues de réglage
- Rallonge
- Certificat de garantie
- Mode d'emploi
- Certificat de calibrage
- Pile LR44 1,5 V

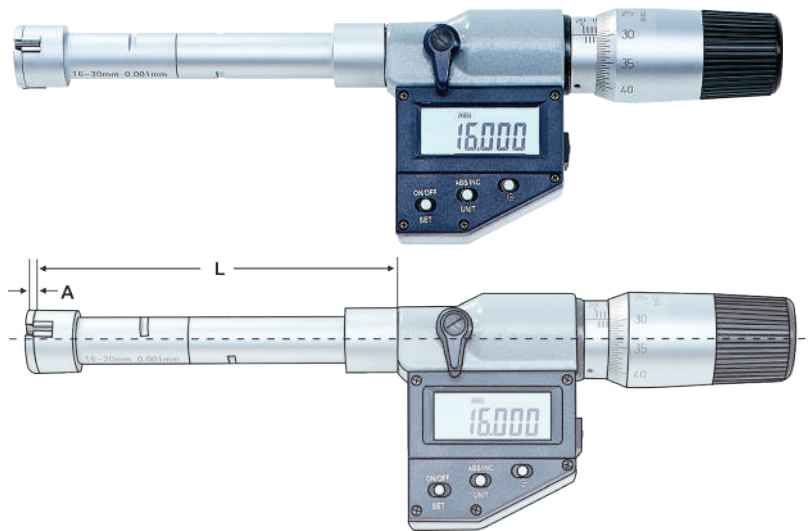

Bestell-Nr. Order no. Références	Messbereich Range Gamme de mesure	Skalenwert Scala Gamme	Genauigkeit Accuracy Précision	Einstellring Setting ring Bague de réglage	Verlängerung Extension rod Rallonge	L	A
M.208.24.0	12 - 16	0,001	0,004	16	150	80	0,5
M.208.25.0	16 - 20	0,001	0,004	16	150	80	0,5
M.208.26.0	20 - 25	0,001	0,004	25	150	90	0,5
M.208.27.0	25 - 30	0,001	0,004	25	150	90	0,5
M.208.28.0	30 - 40	0,001	0,004	40	150	97	0,5
M.208.29.0	40 - 50	0,001	0,005	40	150	97	0,5
M.208.30.0	50 - 63	0,001	0,005	62	150	114	0,5
M.208.31.0	62 - 75	0,001	0,005	62	150	114	0,5
M.208.32.0	75 - 88	0,001	0,005	87	150	114	0,5
M.208.33.0	87 - 100	0,001	0,005	87	150	114	0,5

12

Zubehör | Accessories | Accessoires

Batterie | Battery | Pile

M.LR44

Datenverbindung | Data Connection | Connexion de données

M.900.10.0



3 point internal micrometer | digital | IP65 | 100-300mm

Micromètre d'intérieur numérique à 3 touches | digital | IP65 | 100-300mm

DIN
863-4

Kal.-
Zertifi-
kat

mm
-
inch

Absolut
System

IP 65

Ausführung:

- Ablesung: 0.001mm
- Geeignet für Sacklochbohrungen
- Hartmetallmessflächen
- Ablesebauteile mattverchromt
- Gefühlsratsche

Construction:

- Graduation: 0.001mm
- Measuring contact points are designed to allow measurements near to the bottom of blind holes
- Measuring surfaces are carbide
- reading parts brushed chromium-plated
- Ratchet stop

Version:

- Graduation: 0.001 mm
- Pour mesurer les alésages borgnes
- Surfaces de mesure en carbure monobloc
- Parties de lecture chromées mates
- Avec cliquet

Lieferumfang:

- Verlängerung
- Garantieschein
- Bedienungsanleitung
- Kalibrierzertifikat
- LR44 1,5V Batterie

Delivery:

- Extension
- Warranty card
- Instruction manual
- Calibration certificate
- LR44 1,5V Battery

Livraison avec:

- Rallonge
- Certificat de garantie
- Mode d'emploi
- Certificat de calibrage
- Pile LR44 1,5 V

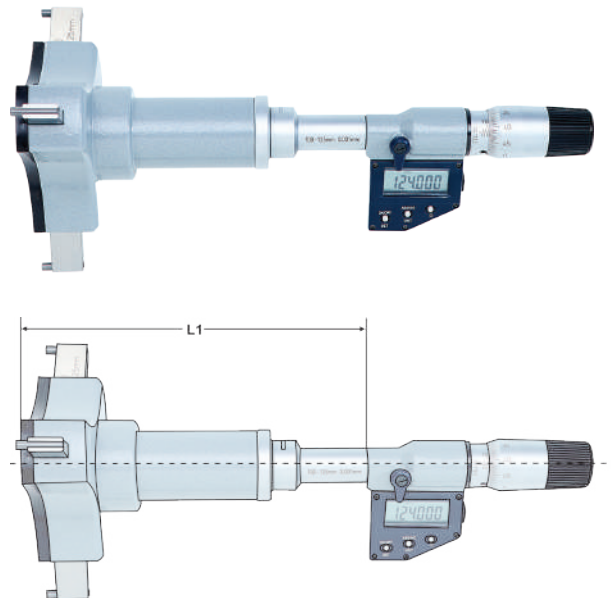

Bestell-Nr. Order no. Références	Messbereich Range Gamme de mesure	Skalenwert Scala Gamme	Genauigkeit Accuracy Précision	Einstellring* Setting ring* Bague de réglage*	Verlängerung Extension rod Rallonge	L1
M.208.34.0	100 - 125	0,001	0,005	112,5	150	145
M.208.35.0	125 - 150	0,001	0,005	137,5	150	145
M.208.36.0	150 - 175	0,001	0,005	162,5	150	145
M.208.37.0	175 - 200	0,001	0,005	187,5	150	145
M.208.38.0	200 - 225	0,001	0,007	212,5	150	145
M.208.39.0	225 - 250	0,001	0,007	237,5	150	145
M.208.40.0	250 - 275	0,001	0,007	262,5	150	145
M.208.41.0	275 - 300	0,001	0,007	287,5	150	145

*Einstellring nicht im Lieferumfang
 *Setting ring not included in delivery
 *bague de réglage non compris

Zubehör | Accessories | Accessoires

Batterie | Battery | Pile
Datenverbindung | Data Connection | Connexion de données

M.LR44
M.900.10.0



Digital indicator | IP65 Comparateur numérique | IP65

DIN 878	Kal.- Zertifi- kat	mm - inch	Absolut System
------------	--------------------------	-----------------	-------------------

Ausführung:

- Geeignet für Sacklochbohrungen
- Hartmetallmessflächen
- Ableseteile mattverchromt
- Gefühlsratsche

Construction:

- Suitable for blind holes
- Carbide surfaces
- Reading parts dull chromed
- Ratchet stop

Version:

- Pour mesurer les alésages borgnes
- Surfaces de mesure en carbure
- Lectures chromé mat
- Avec cliquet

Lieferumfang:

- Verlängerung
- Garantieschein
- Bedienungsanleitung
- Kalibrierzertifikat
- CR2032 3,0V Batterie

Delivery:

- Extension rod
- Warranty card
- Instruction manual
- Calibration certificate
- CR2032 3,0V Battery

Livraison avec:

- Rallonge
- Certificat de garantie
- Mode d'emploi
- Certificat de calibrage
- CR2032 3,0V Pile

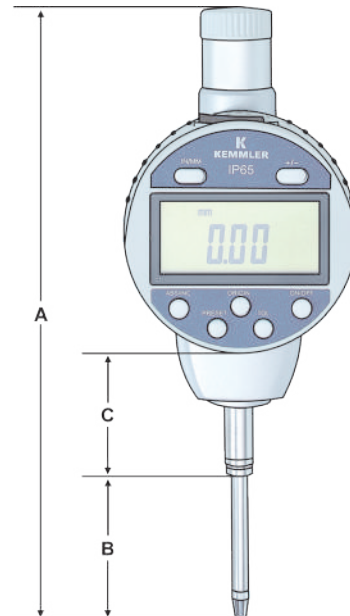

Bestell-Nr. Order no. Références	Messbereich Range Gamme de mesure	Skalenwert Scala Gamme	Genauigkeit Accuracy Précision	A	B	C
M.407.02.2	0 - 25	0,01	0,02	169	26,5	34,3
M.407.03.2	0 - 50	0,01	0,02	246	52	33,7
M.407.02.4	0 - 25	0,001	0,005	169	26,5	34,3
M.407.03.4	0 - 50	0,001	0,006	246	52	33,7

Zubehör | Accessories | Accessoires

Batterie | Battery | Pile

M.CR2032

Datenverbindung | Data Connection | Connexion de données

M.900.07.0 | M.900.07.1 | M.901.00.3 | M.901.00.2



Dial indicator analogue

Comparateur de précision analogique

DIN
878

Kal.-
Zertifi-
kat

mm
-
inch

Ausführung:

- Skalenteilung: 0.01mm; 0.001mm
- Gehäusedurchmesser: Ø 58mm
- Metallgehäuse mit drehbarem Ziffernblatt
- Leicht zu lesendes Ziffernblatt
- Steingelagert
- Schaft Durchmesser: Ø 8mm h6

Construction:

- Graduation: 0.01mm; 0.001mm
- Dial face dia.: Ø58mm
- Metal housing with rotating lever gauge
- Easy to read dial face
- Jeweled
- Stem diameter: Ø 8mm h6

Version:

- Graduation: 0.01mm; 0.001mm
- Diamètre du boîtier: Ø58mm
- Boîtier métallique avec le cadran rotatif
- Lecture facile
- Palier en pierre
- Diamètre du queue: Ø 8mm h6

Lieferumfang:

- Garantieschein
- Bedienungsanleitung
- Kalibrierzertifikat

Delivery:

- Warranty card
- Instruction manual
- Calibration certificate

Livraison avec:

- Certificat de garantie
- Mode d'emploi
- Certificat de calibrage

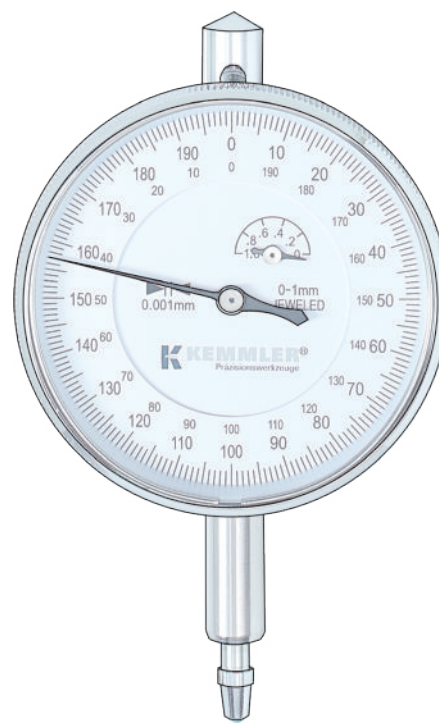
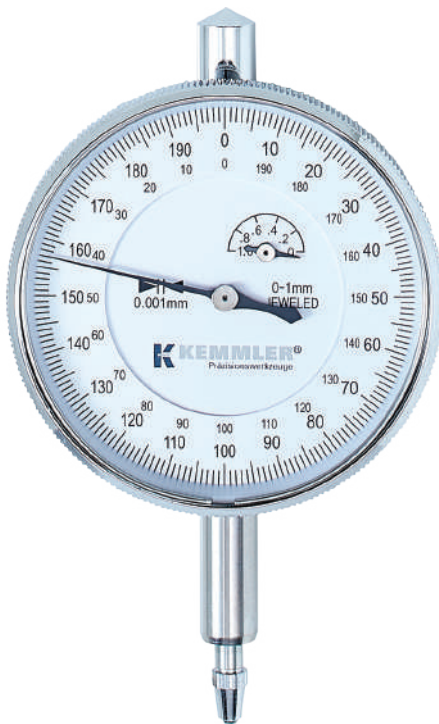

Bestell-Nr. Order no. Références	Messbereich Range Gamme de mesure	Skalenwert Scala Gamme	Ablesung Dial reading Lecture	Genauigkeit Accuracy Précision	Außenring Ø Outer ring Ø Bague extérieure Ø
M.402.01.0	1	0,001	0 - 200	0,005	58
M.402.03.0	3	0,01	0 - 100	0,010	58
M.402.05.0	5	0,01	0 - 100	0,012	58
M.402.10.0	10	0,01	0 - 100	0,015	58
M.402.25.0	25	0,01	0 - 50 - 0	0,035	58
M.402.30.0	30	0,01	0 - 100	0,035	58



Präzisions Messuhr analog

Dial indicator precision analogue
Comparteur de précision analogique

DIN
878

Kal.-
Zertifi-
kat

mm

Ausführung:

- Auflösung: 0.001 mm
- hohe Genauigkeit
- steingelagert und stoßfest
- wasser- und staubgeschütztes Design
- Schaftdurchmesser: 8 mm

Construction:

- Resolution: 0.001 mm
- High accuracy
- Jeweled and shock proof
- Water and dust resistant design
- With 8 mm stem diameter

Version:

- Résolution: 0.001 mm
- Haute précision
- Palier en pierre et anti-choc
- Protégé contre les projections d'eau et la poussière
- Diamètre de la queue 8 mm

Lieferumfang:

- Garantieschein
- Bedienungsanleitung
- Kalibrierzertifikat

Delivery:

- Warranty card
- Instruction manual
- Calibration certificate

Livraison avec:

- Certificat de garantie
- Mode d'emploi
- Certificat de calibrage

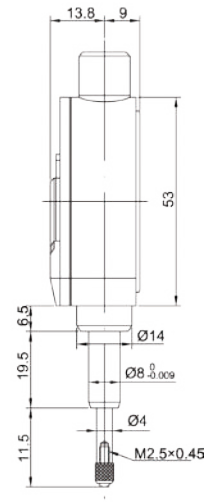
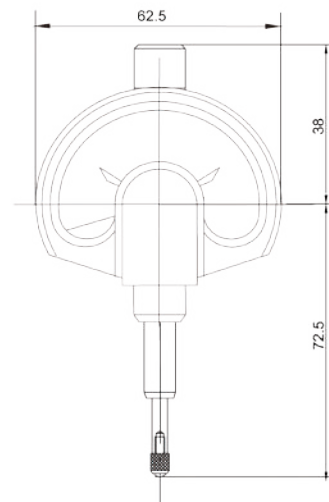

Bestell-Nr. Order no. Références	Messbereich Range Gamme de mesure	Skalenwert Scala Gamme	Ablesung Dial reading Lecture	Genauigkeit Accuracy Précision	Außenring Ø Outer ring Ø Bague extérieure Ø
M.422.21.2	0,05	0,001	50 - 0 - 50	0,0012	62

Dial test indicator

Appareil de mesure à levier

DIN 2270	Kal.- Zertifi- kat	mm
-------------	--------------------------	----

Ausführung:

- Skaleneinteilung: 0.002 mm oder 0.01 mm
- Steingelagert
- 8mm Schwalbenschwanzaufnahme
- Leicht zu lesendes Ziffernblatt
- 2mm Kontaktspitze aus Hartmetall
- Durchmesser von 32 mm oder 40 mm Gehäuse wählbar

Construction:

- Graduation: 0.002mm or 0.01mm
- Jeweled bearings
- With Ø8mm dovetail stems
- Easy to read face
- Ø2mm Carbide tipped contact point
- Ø32mm and Ø40mm dial face are optional

Version:

- Graduation: 0.002 mm ou 0.01 mm
- Palier en pierre
- Logement queue d'aronde 8 mm
- Lecture facile
- Pointe de contact 2 mm en carbure monobloc
- Diamètre du boîtier Ø32 mm ou Ø40 mm au

Lieferumfang:

- Einspannschaft, Schlüssel
- Garantieschein
- Bedienungsanleitung
- Kalibrierzertifikat

Delivery:

- Stem, Wrench
- Warranty card
- Instruction manual
- Calibration certificate

Livraison avec:

- Queue de serrage, clé
- Certificat de garantie
- Mode d'emploi
- Certificat de calibrage

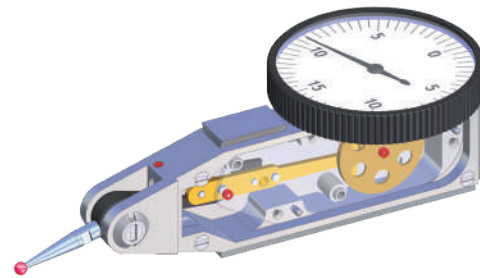

Bestell-Nr. Order no. Références	Messbereich Range Gamme de mesure	Skalenswert Scala Gamme	Ablesung Dial reading Lecture	Genauigkeit Accuracy Précision	Außenring Ø Outer ring Ø Bague extérieure Ø
M.501.02.2	0,2	0,002	0 - 100 - 0	0,004	32
M.501.08.2	0,8	0,01	0 - 40 - 0	0,013	32
M.502.02.2	0,2	0,002	0 - 100 - 0	0,004	40
M.502.08.2	0,8	0,01	0 - 40 - 0	0,013	40

K Magnet-Messtativ mit Feineinstellung

Magnetic base with fine adjustment
Support magnétique avec réglage fin

Ausführung:

- Halterungsmechanismus für Fühlhebelmessgeräte und Messuhren 3/8" und 8 mm Einspannschaft
- Der Magnet wird durch einen Drehschalter an oder aus geschaltet
- Prismatische Sohle mit Feineinstellung
- 80kg Haltekraft

Construction:

- *holding device for test indicators and dial gauges 3/8" and 8 mm stem*
- *The magnet is switched on or off by a rotary knob*
- *prismatic base*
- *With Fine Adjustment*
- *80kg holding force*

Version:

- Mécanisme de fixation pour l'appareil de mesure à levier et comparateurs 3/8" et tige de serrage de 8 mm
- L'aimant est activé ou désactivé par le interrupteur tournant
- Semelle prismatique
- Avec le réglage fin
- Force de maintien 80 kg

Lieferumfang:

- Garantieschein
- Bedienungsanleitung

Delivery:

- *Warranty card*
- *Instruction manual*

Livraison avec:

- Certificat de garantie
- Mode d'emploi

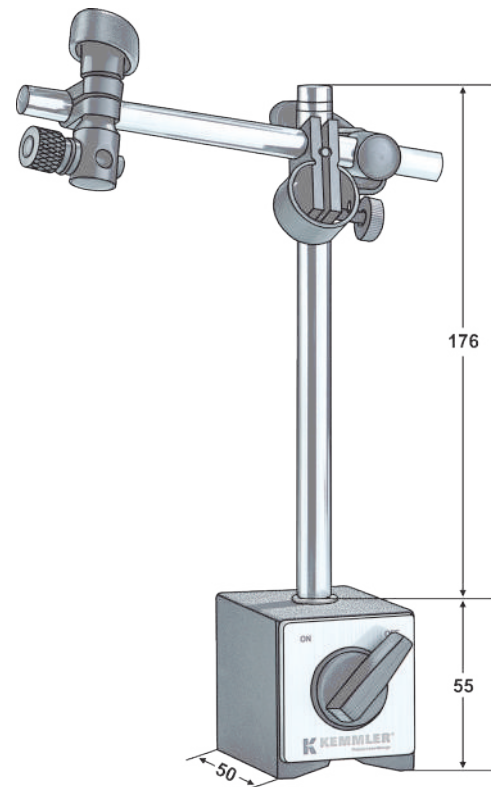

12

Bestell-Nr. Order no. Références	Haftkraft Prisma Adhesive force prism Force d'adhérence prisme	Prisma Prism Prisme	Aufnahmebohrung Mounting hole Alésage de logement	Säulen Column colonne	Querarm Cross arm bras trans.
M.601.02.0	80kg	60x50x55 (LxWxH)	Ø 3/8" + 8 mm	Ø 12 x 176	Ø 10 x 150

Magnetic base with flexible arm
Base magnétique flexible

Ausführung:

- Halterungsmechanismus für Fühlhebelmessgeräte und Messuhren und 8 mm Einspannschaft
- Der Magnet wird durch einen Drehschalter an oder aus geschaltet
- Prismatische Sohle
- 60kg Haltekraft

Construction:

- *holding device for test indicators and dial gauges 8 mm stem*
- *The magnet is switched on or off by a rotary knob*
- *prismatic base*
- *With Fine Adjustment*
- *60kg holding force*

Version:

- Mécanisme de fixation pour l'appareil de mesure à levier et comparateurs, et tige de serrage de 8 mm
- L'aimant est activé ou désactivé par le régulateur tournant
- Semelle prismatique
- Force de maintien 60 kg

Lieferumfang:

- Garantieschein
- Bedienungsanleitung

Delivery:

- *Warranty card*
- *Instruction manual*

Livraison avec:

- Certificat de garantie
- Mode d'emploi



Bestell-Nr. Order no. Références	Haftkraft Prisma Adhesive force prism Force d'adhérence prisme	Gesamthöhe Total height Hauteur totale	Prisma Prism Prisme	Aufnahmebohrung Mounting hole Alésage de logement
M.601.11.0	60kg	360	60x50x55 (LxWxH)	8 mm



Präzisions Magnet Messstativ

Precision Magnetic base
Base magnétique de précision

Ausführung:

- Halterungsmechanismus für Fühlhebelmessgeräte und Messuhren 3/8" und 8 mm Einspannschaft
- Der Magnet wird durch einen Drehschalter an oder aus geschaltet.
- Prismatische Sohle
- 80kg +130kg Haltekraft

Construction:

- *holding device for test indicators and dial gauges 3/8" and 8 mm stem*
- *The magnet is switched on or off by a rotary knob*
- *prismatic base*
- *80kg + 130 kg holding force*

Version:

- Mécanisme de fixation pour l'appareil de mesure à levier et comparateurs 3/8" et tige de serrage de 8 mm
- L'aimant est activé ou désactivé par le régulateur tournant
- Semelle prismatique
- Force de maintien 80 kg + 130 kg

Lieferumfang:

- Garantieschein
- Bedienungsanleitung

Delivery:

- *Warranty card*
- *Instruction manual*

Livraison avec:

- *Certificat de garantie*
- *Mode d'emploi*

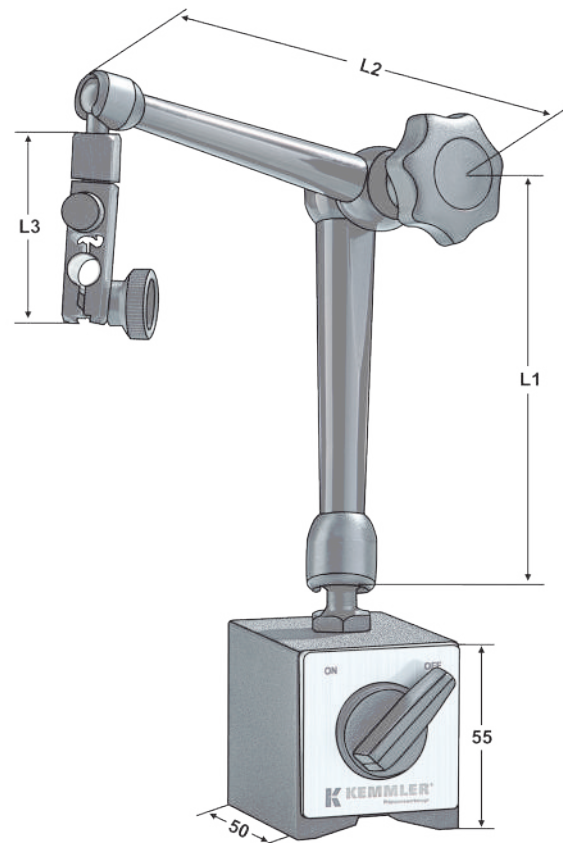

Bestell-Nr. Order no. Références	Haftkraft Prisma Adhesive force prism Force d'adhérence prisme	Prisma Prism Prisme	Aufnahmebohrung Mounting hole Alésage de logement	L1	L2	L3
M.602.02.1	80kg	60x50x55 (LxWxH)	Ø 3/8" + 8 mm	110	101	73
M.602.05.1	130kg	117x50x55 (LxWxH)	Ø 3/8" + 8 mm	285	225	76

Digital height gauge with hand wheel Trusquin avec volant

Kal.-
Zertifi-
kat

mm
-
inch

Ausführung:

- Auflösung: .0005" / 0.01 mm
- extra großes LCD display
- Verstellung über Handrad
- inch/metrisch
- Ausgangsposition wird beim Wiederanschalten beibehalten
- Auswechselbare Hartmetall Anreißnadel
- Nullstellung bei jeder Position möglich

Construction:

- Resolution: .0005" / 0.01mm
- Large LCD display
- Hand wheel design for fine adjustment
- Metric/Inch conversion at any position
- Starting position is kept when turned on
- Exchangeable carbide tipped scriber
- Zero-setting at any position

Version:

- Résolution: .0005" / 0.01 mm
- Affichage LCD extra large
- Réglage par volant
- Pouce/ métrique
- Position initiale maintenue lors de la mise en marche
- Aiguille de traçage en métal dur remplaçable
- Remise à zero possible à chaque position

Lieferumfang:

- Hartmetall Anreißnadel mit Halterung
- Garantieschein
- Bedienungsanleitung
- Kalibrierzertifikat
- LR44 1,5V Batterie

Delivery:

- Carbide tipped scriber with clamp
- Warranty card
- Instruction manual
- Calibration certificate
- LR44 1,5V Battery

Livraison avec:

- Pointe à tracer en carbure avec support
- Certificat de garantie
- Mode d'emploi
- Certificat de calibrage
- Pile LR44 1,5V

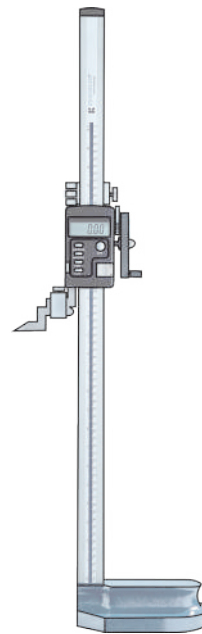

Bestell-Nr. Order no. Références	Messbereich Range Gamme de mesure	Skalenwert Scala Gamme	Genauigkeit Accuracy Précision
M.626.12.0	0 - 300	0,01	± 0,04
M.626.24.0	0 - 600	0,01	± 0,05



Digital height gauge Trusquin



Ausführung:

- Auflösung: .0005" / 0.01 mm
- extra großes LCD display
- Verstellung über Handrad
- inch/metrisch
- Ausgangsposition wird beim Wiederanschalten beibehalten
- Auswechselbare Hartmetall Anreißnadel
- Schaltet automatisch ab
- Nullstellung bei jeder Position möglich

Construction:

- Resolution: .0005" / 0.01mm
- Large LCD display
- Hand wheel design for fine adjustment
- Metric/Inch conversion at any position
- Starting position is kept when turned on
- Exchangeable carbide tipped scribe
- Automatic switch off
- Zero-setting at any position

Version:

- Résolution: .0005" / 0.01 mm
- Affichage LCD extra large
- Réglage par volant
- Pouce / métrique
- Position initiale maintenue lors de mise en marche
- Aiguille de traçage en métal dur remplaçable
- Arrêt automatique
- Remise à zero possible à chaque position

Lieferumfang:

- Hartmetall Anreißnadel mit Halterung
- Garantieschein
- Bedienungsanleitung
- Kalibrierzertifikat
- LR44 1,5V Batterie

Delivery:

- Carbide tipped scribe with clamp
- Warranty card
- Instruction manual
- Calibration certificate
- LR44 1,5V Battery

Livraison avec:

- Pointe à tracer en carbure avec support
- Certificat de garantie
- Mode d'emploi
- Certificat de calibrage
- Pile LR44 1,5V



Bestell-Nr. Order no. Références	Messbereich Range Gamme de mesure	Skalenwert Scala Gamme	Genauigkeit Accuracy Précision
M.625.12.0	0 - 300	0,01	± 0,04
M.625.24.0	0 - 600	0,01	± 0,05



Digital height gauge with hand wheel Trusquin avec volant

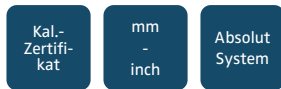

Ausführung:

- Auflösung: .0005" / 0.01 mm
- extra großes LCD display
- Verstellung über Handrad
- inch/metrisch
- Ausgangsposition wird beim Wiederanschalten beibehalten
- Auswechselbare Hartmetall Anreißnadel
- Schaltet automatisch ab
- Nullstellung bei jeder Position möglich

Construction:

- Resolution: .0005" / 0.01mm
- Large LCD display
- Hand wheel design for fine adjustment
- Metric/Inch conversion at any position
- Starting position is kept when turned on
- Exchangeable carbide tipped scriber
- Automatic switch off
- Zero-setting at any position

Version:

- Résolution: .0005" / 0.01 mm
- Affichage LCD extra large
- Réglage par volant
- Pouce / métrique
- Position initiale maintenue lors de mise en marche
- Aiguille de traçage en métal dur remplaçable
- Arrêt automatique
- Remise à zero possible à chaque position

Lieferumfang:

- Hartmetall Anreißnadel mit Halterung
- Garantieschein
- Bedienungsanleitung
- Kalibrierzertifikat
- LR44 1,5V Batterie

Delivery:

- Carbide tipped scriber with clamp
- Warranty card
- Instruction manual
- Calibration certificate
- LR44 1,5V Battery

Livraison avec:

- Pointe à tracer en carbure avec support
- Certificat de garantie
- Mode d'emploi
- Certificat de calibrage
- Pile LR44 1,5V



Bestell-Nr. Order no. Références	Messbereich Range Gamme de mesure	Skalenwert Scala Gamme	Genauigkeit Accuracy Précision
M.627.12.0	0 - 300	0,01	± 0,02
M.627.24.0	0 - 600	0,01	± 0,03



K Höhenmess- und Anreissgerät | analog

Vernier height gauge | analogue
Trusquin | analogique

- Kal.-Zertifikat
- mm - inch
- INOX

Ausführung:

- Ablesung: 0.05mm / 1/128"
- Durch die Feineinstellung kann der Schieber exakt positioniert werden
- Mattes Chrom finish
- Wärmeisolierender Kunststoffgriff

Construction:

- Graduation: 0.05mm / 1/128"
- The fine-adjustment allows the slider to be precisely positioned
- Matt chrome finish
- Stainless steel design
- The base is designed with a thermal heat isolation hand grip

Version:

- Lecture: 0.05 mm / 1 / 128"
- Le réglage fin permet le positionnement exact du poussoir
- Chromé mat
- Poignée plastique thermo-isolante

Lieferumfang:

- Hartmetall Anreißnadel mit Halterung
- Garantieschein
- Bedienungsanleitung
- Kalibrierzertifikat

Delivery:

- Carbide tipped scribe with clamp
- Warranty card
- Instruction manual
- Calibration certificate

Livraison avec:

- Aiguille à tracer en métal dur avec support
- Certificat de garantie
- Mode d'emploi
- Certificat de calibrage

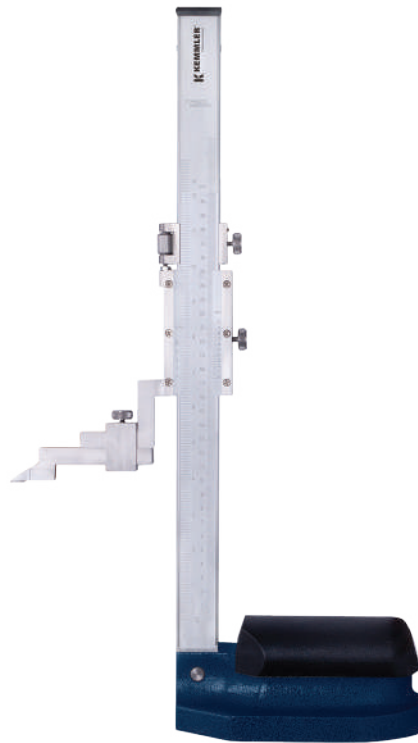

12

Bestell-Nr. Order no. Références	Messbereich Range Gamme de mesure	Skalenwert Scala Gamme	Genauigkeit Accuracy Précision
M.621.12.0	0 - 300	0,05	± 0,05
M.621.24.0	0 - 600	0,05	± 0,10

Prec. bevelled edge, DIN 875 / 00
 Equerres biseautées, DIN 875 / 00

DIN
875

INOX

Ausführung:

- Hergestellt aus gehärtetem Edelstahl
- Gefertigt nach DIN 875

Construction:

- *Made of precision ground hardened stainless steel*
- *Accuracy according to DIN 875*

Version:

- En acier inoxydable trempée
- Fabriqué selon DIN 875



Bestell-Nr. Order no. Références	Abmessung Size Dimension
M.639.22.0	75 x 50
M.639.23.0	100 x 70
M.639.24.0	150 x 100
M.639.25.0	200 x 130
M.639.27.0	300 x 200

Präzisions-Flachwinkel, DIN 875 / 0

Prec. flat square, DIN 875 / 0
 Equerres simples, DIN 875 / 0

DIN
875

INOX

Ausführung:

- Hergestellt aus gehärtetem Edelstahl
- Gefertigt nach DIN 875

Construction:

- *Made of precision ground hardened stainless steel*
- *Accuracy according to DIN 875*

Type:

- En acier inoxydable trempée
- Fabriqué selon DIN 875



Bestell-Nr. Order no. Références	Abmessung Size Dimension
M.639.22.4	75 x 50
M.639.23.4	100 x 70
M.639.24.4	150 x 100
M.639.25.4	200 x 130
M.639.27.4	300 x 200

K Winkelmesser Satz mit Feineinstellung und Lupe

Universal bevel protractor set with fine adjustment
Jeu de rapporteur d'angle à loupe

Kal.-
Zertifi-
kat

mm
-
inch

INOX

Ausführung:

- Ablesung: 1°, Noniuswert 5'
- Für präzise Winkelmessungen
- Vergrößerungsglas für leichteres Ablesen
- Kann mit einem Standard Höhenmessgerät genutzt werden um einen Winkel zur Referenzplatte zu erhalten
- Genauigkeit: ± 5 min

Construction:

- *Dial Graduation: 1°, Vernier: 5'*
- *Designed to provide precise angular measurements*
- *Magnifying glass is provided for easier reading*
- *Can be used with a standard height gauge to provide angular measurement from reference plate*
- *Accuracy: ±5 min*

Version:

- Graduation: 1°, vernier 5'
- Pour mesures d'angles exactes
- Loupe pour lecture facile
- Utilisation avec trusquin standard pour obtenir un angle par rapport au plat de référence
- Précision: ±5 min

Lieferumfang:

- Basis + Messschienen
- Garantieschein
- Bedienungsanleitung
- Kalibrierzertifikat

Delivery:

- *Base + Blades*
- *Warranty card*
- *Instruction manual*
- *Calibration certificate*

Livraison avec:

- Base + barres de mesure
- Certificat de garantie
- Mode d'emploi
- Certificat de calibrage



Bestell-Nr.
Order no.
Références

M.490.06.0

Messbereich
Range
Gamme de mesure

4 x 90°

Schiene
Blade
Barre

150+200+300

Genauigkeit
Accuracy
Précision

± 5 min

Digital protractor 0-360°

Rapporteur d'angle numérique 0-360°



Ausführung:

- Ablesung: 1°, Noniuswert 5'
- Für präzise Winkelmessungen
- Kann mit einem Standard Höhenmessgerät genutzt werden, um einen Winkel zur Referenzplatte zu erhalten
- Genauigkeit: ± 5 min

Construction:

- *Dial Graduation: 1°, Vernier: 5'*
- *Designed to provide precise angular measurements*
- *Can be used with a standard height gauge to provide angular measurement from reference plate*
- *Accuracy: ±5 min*

Version:

- Graduation: 1°, vernier 5'
- Pour mesures d'angles exactes
- Utilisation avec trusquin standard pour obtenir un angle par rapport au plat de référence
- Précision: ±5 min

Lieferumfang:

- Basis + Messschienen
- Garantieschein
- Bedienungsanleitung
- Kalibrierzertifikat
- CR2032 3,0V Batterie

Delivery:

- *Base + Blades*
- *Warranty card*
- *Instruction manual*
- *Calibration certificate*
- *CR2032 3,0V Battery*

Livraison avec:

- Base + barres de mesure
- Certificat de garantie
- Mode d'emploi
- Certificat de calibrage
- Pile CR2032 3,0V



Bestell-Nr. Order no. Références	Messbereich Range Gamme de mesure	Schiene Blade Barre	Genauigkeit Accuracy Précision
M.490.15.2	360°	150 + 300	± 5 min





Stahl Parallelendmaß Satz

Rectangular gauge block set
Jeu de cales étalons parallèles en acier

ISO
3650

Kal.-
Zertifi-
kat



Ausführung:

- Individuelle Seriennummern auf jedem Block
- Ein auf N.I.S.T. oder P.T.B. rückführbares Kalibrierzertifikat zeigt die Abweichung jedes Maßes
- Feingeläppte Oberfläche
- DIN EN ISO 3650

Construction:

- Individual serial numbers on each block, regardless of grade
- A complete certificate of calibration traceable to the N.I.S.T or P.T.B showing the deviation of each block
- Mirror polished surfaces
- DIN EN ISO 3650

Version:

- Numéro de série individuel
- Certificat de calibrage équivalent à N.I.S.T. ou P.T.B. indique écarts de tolérance
- Surface rodée finement
- DIN EN ISO 3650

Bestell-Nr. Order no. Références	Toleranzklasse Tolerance class Classe de tolérance	Anzahl Endmaße Number of gauge blocks Nombre de cales étalons
M.650.16.0	0	= 32 = 1 St. pcs. : 1.005mm 9 St. pcs. : 1.01 - 1.09mm x 0.01mm Stufung step pas 9 St. pcs. : 1.1 - 1.9mm x 0.1mm Stufung step pas 9 St. pcs. : 1- 9mm x 1mm Stufung step pas 4 St. pcs. : 10mm 20mm 30mm 50mm
M.650.16.2	2	= 32 = 1 St. pcs. : 1.005mm 9 St. pcs. : 1.01 - 1.09mm x 0.01mm Stufung step pas 9 St. pcs. : 1.1 - 1.9mm x 0.1mm Stufung step pas 9 St. pcs. : 1- 9mm x 1mm Stufung step pas 4 St. pcs. : 10mm 20mm 30mm 50mm
M.650.14.0	0	= 47 = 1 St. pcs. : 1.005mm 20 St. pcs. : 1.01- 1.20mm x 0.01mm Stufung Stufung step pas 7 St. pcs. : 1.3 - 1.9mm x 0.1mm Stufung Stufung step pas 9 St. pcs. : 1- 9mm x 1mm Stufung Stufung step pas 10 St. pcs. : 10 - 100mm x 10mm Stufung Stufung step pas
M.650.14.2	2	= 47 = 1 St. pcs. : 1.005mm 20 St. pcs. : 1.01- 1.20mm x 0.01mm Stufung Stufung step pas 7 St. pcs. : 1.3 - 1.9mm x 0.1mm Stufung Stufung step pas 9 St. pcs. : 1- 9mm x 1mm Stufung Stufung step pas 10 St. pcs. : 10 - 100mm x 10mm Stufung Stufung step pas
M.650.13.0	0	= 87 = 9 St. pcs.: 1.001- 1.009mm x 0.001mm Stufung step pas 49 St. pcs.: 1.01- 1.49mm x 0.01mm Stufung step pas 19 St. pcs.: 0.5 - 9.5mm x 0.5mm Stufung step pas 10 St. pcs.: 10 - 100mm x 10mm Stufung step pas
M.650.13.2	2	= 87 = 9 St. pcs.: 1.001- 1.009mm x 0.001mm Stufung step pas 49 St. pcs.: 1.01- 1.49mm x 0.01mm Stufung step pas 19 St. pcs.: 0.5 - 9.5mm x 0.5mm Stufung step pas 10 St. pcs.: 10 - 100mm x 10mm Stufung step pas
M.650.12.0	0	= 103 = 1 St. pcs.: 1.005mm 49 St. pcs.: 1.01- 1.49mm x 0.01mm Stufung step pas 49 St. pcs.: 0.5- 24.5mm x 0.5mm Stufung step pas 4 St. pcs.: 25 - 100mm x 25mm Stufung step pas
M.650.12.2	2	= 103 = 1 St. pcs.: 1.005mm 49 St. pcs.: 1.01- 1.49mm x 0.01mm Stufung step pas 49 St. pcs.: 0.5- 24.5mm x 0.5mm Stufung step pas 4 St. pcs.: 25 - 100mm x 25mm Stufung step pas



Technische Datenblätter, STEP/STL Modelle für die Simulation der NC-Programme und DXF-Zeichnungen zur Erstellung des Einrichteblattes stehen Online zur Verfügung.

Technical data sheets, STEP/STL models for the simulation of NC programs and DXF drawings to create the tooling sheet are online available.

Fiches techniques, STEP/STL modèles techniques pour la simulation de programmes CN et dessins DXF pour créer la feuille d'installation sont disponible online.

Sie können unsere Kataloge entweder direkt im Browser betrachten oder sie auf Ihren PC, Smartphone oder Tablet herunterladen (PDF-Reader notwendig).

You can view our catalogues either directly in the browser or download to your PC, smartphone or tablet (PDF reader required).

Vous pouvez consulter nos catalogues directement dans le navigateur ou le télécharger sur votre PC, smartphone ou tablet (lecteur PDF requis).

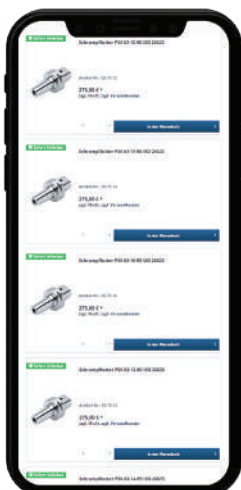

Auf unserer Internetseite können Sie die Lagerverfügbarkeit prüfen - auch auf Mobilgeräten.

On our website you can check the stock availability - also on mobile devices.

Vous pouvez également vérifier la disponibilité de nos produits sur le site Internet - ainsi que sur vos appareils

K Grenzlehrdorn | H7

Plug gauge | H7
Tampon lisse | H7



Ausführung:

- Gehärteter Lehrenstahl
- Grenzlehrdorn-Genauigkeit DIN 7162/7164
- Grenzlehrdorn-Größe DIN 2245

Construction:

- Hardened steel
- Plug Gauge Accuracy according to DIN 7162/7164
- Plug gauge sizes according to DIN 2245

Version:

- En acier calibré, trempé
- Précision tampons lisses DIN 7162/7164
- Taille tampons lisses DIN 2245



Bestell-Nr. Order no. Références	Messbereich Range Gamme de mesure
M.670.02.7	2mm
M.670.03.7	3mm
M.670.04.7	4mm
M.670.05.7	5mm
M.670.06.7	6mm
M.670.07.7	7mm
M.670.08.7	8mm
M.670.09.7	9mm
M.670.10.7	10mm
M.670.11.7	11mm
M.670.12.7	12mm
M.670.13.7	13mm
M.670.14.7	14mm
M.670.15.7	15mm
M.670.16.7	16mm
M.670.17.7	17mm
M.670.18.7	18mm
M.670.19.7	19mm
M.670.20.7	20mm
M.670.21.7	21mm
M.670.22.7	22mm
M.670.23.7	23mm
M.670.24.7	24mm
M.670.25.7	25mm
M.670.26.7	26mm
M.670.27.7	27mm
M.670.28.7	28mm
M.670.30.7	30mm
M.670.32.7	32mm

Bestell-Nr. Order no. Références	Messbereich Range Gamme de mesure
M.670.34.7	34mm
M.670.35.7	35mm
M.670.36.7	36mm
M.670.37.7	37mm
M.670.38.7	38mm
M.670.40.7	40mm
M.670.42.7	42mm
M.670.44.7	44mm
M.670.45.7	45mm
M.670.46.7	46mm
M.670.47.7	47mm
M.670.48.7	48mm
M.670.50.7	50mm
M.670.52.7	52mm
M.670.55.7	55mm
M.670.60.7	60mm
M.670.62.7	62mm
M.670.65.7	65mm
M.670.68.7	68mm
M.670.70.7	70mm
M.670.72.7	72mm
M.670.75.7	75mm
M.670.80.7	80mm
M.670.85.7	85mm
M.670.90.7	90mm
M.670.95.7	95mm
M.670.98.7	98mm

Ring gauge Bague de réglage



Ausführung:

- Gehärteter Lehenstahl
- Leerring-Genauigkeit DIN 2250

Construction:

- *Hardened steel*
- *Ring gauge accuracy according to DIN 2250*

Version:

- En acier calibré, trempé
- Précision bagues lisses selon DIN 2250



Bestell-Nr. Order no. Références	Messbereich Range Gamme de mesure
M.675.02.0	2mm
M.675.02.2	2,2mm
M.675.02.5	2,5mm
M.675.02.8	2,8mm
M.675.03.0	3mm
M.675.03.5	3,5mm
M.675.04.0	4mm
M.675.04.5	4,5mm
M.675.05.0	5mm
M.675.06.0	6mm
M.675.07.0	7mm
M.675.08.0	8mm
M.675.09.0	9mm
M.675.10.0	10mm
M.675.11.0	11mm
M.675.12.0	12mm
M.675.13.0	13mm
M.675.14.0	14mm
M.675.15.0	15mm
M.675.16.0	16mm
M.675.17.0	17mm
M.675.18.0	18mm
M.675.19.0	19mm
M.675.20.0	20mm
M.675.21.0	21mm
M.675.22.0	22mm
M.675.23.0	23mm
M.675.24.0	24mm
M.675.25.0	25mm
M.675.26.0	26mm
M.675.27.0	27mm
M.675.28.0	28mm
M.675.30.0	30mm
M.675.32.0	32mm

Bestell-Nr. Order no. Références	Messbereich Range Gamme de mesure
M.675.33.0	33mm
M.675.34.0	34mm
M.675.35.0	35mm
M.675.36.0	36mm
M.675.37.0	37mm
M.675.38.0	38mm
M.675.40.0	40mm
M.675.42.0	42mm
M.675.44.0	44mm
M.675.45.0	45mm
M.675.46.0	46mm
M.675.47.0	47mm
M.675.48.0	48mm
M.675.50.0	50mm
M.675.52.0	52mm
M.675.55.0	55mm
M.675.58.0	58mm
M.675.60.0	60mm
M.675.62.0	62mm
M.675.65.0	65mm
M.675.68.0	68mm
M.675.70.0	70mm
M.675.72.0	72mm
M.675.75.0	75mm
M.675.80.0	80mm
M.675.82.0	82mm
M.675.85.0	85mm
M.675.88.0	88mm
M.675.90.0	90mm
M.675.92.0	92mm
M.675.95.0	95mm
M.675.98.0	98mm
M.676.00.0	100mm

Thread plug gauge | 6H Tampons filetés | 6H

DIN 13

Kal.-
Zertifi-
kat

Ausführung:

Der angeschliffene erste Gewindegang entfernt groben Schmutz im Werkstück und verhindert das vorzeitige Ausbrechen des ersten Gewindeganges.

Gut- und Ausschussseite auf einem Griff (DIN 2240, Teil 1, Form R). Ausschussseite rot gekennzeichnet.

Bei Gewinden grösser als M40 sind Gut- und Ausschusssporn separat (DIN 2240, Teil 2, Form GE)

- Gehärteter Lehrenstahl
- Für metrische ISO-Gewinde
- DIN 13
- 6H
- Toleranzen und Abmaße nach DIN ISO 1502
- Ausführung gemäß DIN 2279 - 2299

Construction:

The ground first thread pitch removes coarse swarf in the component and prevents premature fracture of the first thread pitch.

"Go" and "No Go" ends on a single handle (DIN 2240, part 1, form R). "No Go" end marked red.

M40 and above "Go" and "No Go" gauges are separate (DIN 2240, part 2, form GE)

- Hardened steel
- ISO-Metric Thread
- DIN 13
- 6H
- Tolerances and dimensions to DIN ISO 1502
- Version to DIN 2279 - 2299

Version:

Le premier pas est tronqué pour éliminer les impuretés sur la pièce et empêcher le dérapage prématuré du premier pas.

Côté ENTRE et N'ENTRE PAS sur une poignée (DIN 2240, partie 1, forme R). Côté N'ENTRE PAS marqué en rouge.

Chez les filets qui sont plus grands que M40 les tampons ENTRE et N'ENTRE PAS sont séparés (DIN 2240, partie 2, forme GE).

- En acier calibré, trempé
- Filetage métrique ISO
- DIN 13
- 6H
- Tolérances et dimensions suivant DIN ISO 1502
- Version selon DIN 2279 - 2299



Bestell-Nr. Order no. Références	Gewinde Thread Filetage	Steigung Thread lead Pas de filetage
M.680.02.0	M2	0,40
M.680.02.5	M2,5	0,45
M.680.03.0	M3	0,50
M.680.03.5	M3,5	0,60
M.680.04.2	M4	0,70
M.680.05.2	M5	0,80
M.680.06.2	M6	1,00
M.680.08.2	M8	1,25
M.680.09.2	M9	1,25
M.680.10.2	M10	1,50
M.680.12.2	M12	1,75
M.680.14.2	M14	2,00
M.680.16.2	M16	2,00
M.680.18.2	M18	2,50
M.680.20.2	M20	2,50
M.680.22.2	M22	2,50
M.680.24.2	M24	3,00
M.680.27.2	M27	3,00
M.680.30.2	M30	3,50
M.680.33.2	M33	3,50
M.680.36.2	M36	4,00
M.680.39.2	M39	4,00
M.680.42.2	M42	4,50
M.680.45.2	M45	4,50
M.680.48.2	M48	5,00
M.680.52.2	M52	5,00
M.680.56.2	M56	5,50
M.680.60.2	M60	5,50

Ring gauge „GO“ | Ring gauge „NO GO“ | 6g
 Bague filetée ENTRE | Bague filetée N'ENTRE PAS | 6g

DIN 13
 Kal.-
 Zertifi-
 kat

Ausführung:

- Gehärteter Lehenstahl
- Für metrische ISO-Gewinde
- DIN 13
- 6g

Construction:

- *Hardened steel*
- *ISO-Metric Thread*
- *DIN 13*
- *6g*

Version:

- En acier calibré, trempé
- Filetage métrique ISO
- DIN 13
- 6g

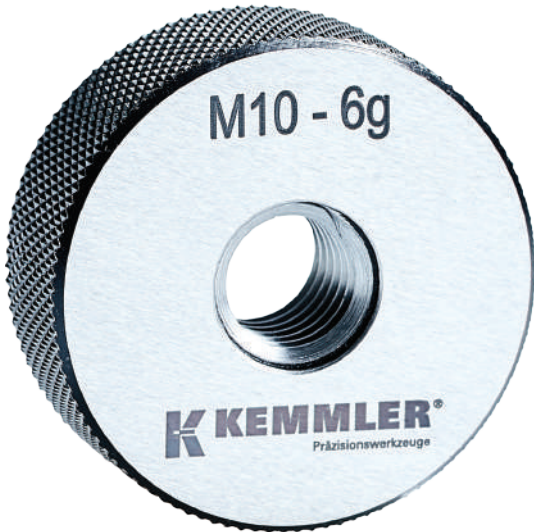

Bestell-Nr. Order no. Références	Messbereich „Go“ Range „Go“ Gamme de mesure „Go“
M.683.03.1	M3
M.683.03.6	M3,5
M.683.04.1	M4
M.683.05.1	M5
M.683.06.1	M6
M.683.08.1	M8
M.683.09.1	M9
M.683.10.1	M10
M.683.12.1	M12
M.683.14.1	M14
M.683.16.1	M16
M.683.18.1	M18
M.683.20.1	M20
M.683.22.1	M22
M.683.24.1	M24
M.683.27.1	M27
M.683.30.1	M30
M.683.33.1	M33
M.683.36.1	M36
M.683.39.1	M39
M.683.42.1	M42
M.683.45.1	M45
M.683.48.1	M48
M.683.52.1	M52
M.683.56.1	M56
M.683.60.1	M60

Bestell-Nr. Order no. Références	Messbereich „No Go“ Range „No Go“ Gamme de mesure „No Go“
M.684.03.0	M3
M.684.03.5	M3,5
M.684.04.0	M4
M.684.05.0	M5
M.684.06.0	M6
M.684.08.0	M8
M.684.09.0	M9
M.684.10.0	M10
M.684.12.0	M12
M.684.14.0	M14
M.684.16.0	M16
M.684.18.0	M18
M.684.20.0	M20
M.684.22.0	M22
M.684.24.0	M24
M.684.27.0	M27
M.684.30.0	M30
M.684.33.0	M33
M.684.36.0	M36
M.684.39.0	M39
M.684.42.0	M42
M.684.45.0	M45
M.684.48.0	M48
M.684.52.0	M52
M.684.56.0	M56
M.684.60.0	M60



Gewinde-Grenzlehrdorne | M3-M12 | DIN 13 | Satz | im Holzkasten

Thread plug gauge | M3-M12 | DIN 13 | set | in wooden box
Filetage Tampon fileté double | M3-M12 | jeu | dans socles en bois

DIN 13

Kal.-
Zertifi-
kat



Bestell-Nr.
Order no.
Références

Abmessung
Size
Dimension

M.680.S Bestehend aus: | *Consisting of:* | Composé de:

M.680.03.0 M3 x 0,50

M.680.04.2 M4 x 0,70

M.680.05.2 M5 x 0,80

M.680.06.2 M6 x 1,00

M.680.08.2 M8 x 1,25

M.680.10.2 M10 x 1,75

M.680.12.2 M12 x 2,00

Holzkästen leer für Gewindegrenzlehrdorne



Wooden boxes, empty for Thread plug gauge
Coffrets en bois, vides pour filetage tampon



Bestell-Nr.
Order no.
Références

Abmessung
Size
Dimension

M.680.701

Für 7 Stück | for 7 pcs. | pour 7 pcs.



Kantentaster mechanisch

Edge finders mechanical
Palpeurs d'angle mécanique



Verwendung:
Zum Ausrichten von Werkstück-Bezugsflächen oder Kanten. Drehzahl der Spindel ca. 600 U/min.

Application:
For alignment of component reference surfaces or edges. Spindle speed approx. 600 rpm.

Utilisation:
Pour aligner les surfaces ou les arêtes. La Vitesse env. 600 tr/min.

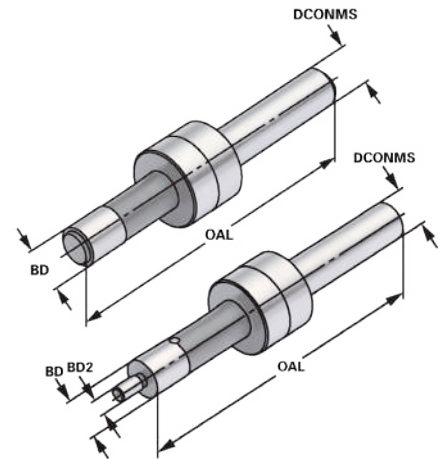

Bestell-Nr. Order no. Référence	DCONMS	OAL	BD	BD2
702.10	10	84	10	-
702.10.4	10	94	10	4

Ausführung: Der Tastkopf ist über eine Feder mit dem Einspannschaft elastisch verbunden und ermöglicht eine Ausricht-Genauigkeit von 0,01 mm. Alle Teile ganz gehärtet und geschliffen.
Gr. 10: Mit einfachem Tastkopf 10 mm Ø.
Gr. 10/4: Mit abgesetztem Tastkopf 10 und 4 mm Ø.

Version: The contact point has a flexible connection to the body via a spring, with an alignment accuracy of 0.01 mm. All parts fully hardened and ground.
Size 10: With parallel contact point 10 mm Ø.
Size 10/4: With stepped contact point 10 and 4 mm Ø.

Version: La tête de palpation est fixée de façon élastique avec la tige de fixation par un ressort. Cela permet la précision du réglage de 0,01 mm. Toutes les pièces sont entièrement trempées et rectifiées.
Réf. 10: Avec palpeur simple Ø 10 mm.
Réf. 10/4: Avec palpeur détaché Ø 10 ou 4 mm.



Verwendung:
Ersatzfeder für Kantentaster 702.10 + 702.10.4

Application:
Springs for edgefinder 702.10 + 702.10.4

Usinage:
Ressorts pour palpeurs d'angle mécanique pour 702.10 + 702.10.4

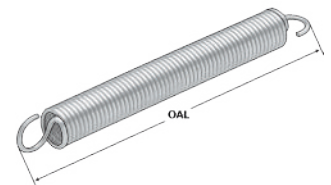

12

Bestell-Nr. Order no. Référence	OAL
702.E10-10.4	44

Edge finders electronic 2D

Palpeurs d'angle électroniques 2D



Verwendung:
Ausrichten von Werkstück-Bezugsflächen oder Kanten. Bestimmen von Bohrungsmittelpunkten zentrisch zur Arbeitsspindel.

Application:
Alignment of component reference surfaces or edges. Determination of bore centres to the machine spindle.

Utilisation:
Pour aligner les surfaces ou les arêtes. Détermination du point de perçage centré par rapport à la broche de travail.

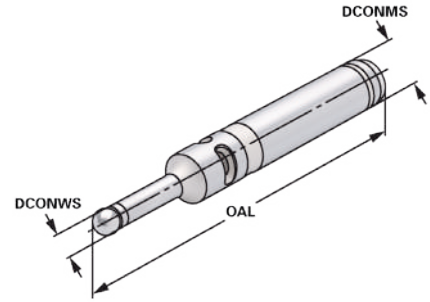

Bestell-Nr. Order no. Référence	DCONMS	OAL	DCONWS
702.16	16	100	10
702.20	20	160	10

Ausführung: Federgelagerte Tastkugel schützt das Gerät vor Beschädigung, falls zu stark angefahren wird. Funktionsteile gehärtet und geschliffen. Rundlauf-Genauigkeit: $\pm 0,01$ mm.

Version: Spring mounted *spherical tip protects the unit from damage if contact is too strong. Functional parts hardened and ground. Concentricity: ± 0.01 mm.*

Version: La bille de palpation montée sur le ressort protège l'appareil contre les dégâts en cas de contact trop fort. Pièces de fonctionnement trempées et rectifiées. Précision de concentricité: $\pm 0,01$ mm.

Funktion: Bei Kontakt von Tastkugel und metallischem Werkstück beginnt die Lampe zu leuchten = Erkennen des Bezugspunktes

Function: *When contact between the spherical tip and metal component occurs, the control lamp lights up = identification of the reference point.*

Fonction: Lorsque la bille de palpation entre en contact avec une pièce métallique, la lampe s'allume. = identification du point de référence.

Lieferumfang: 1,5 V | LR1 / N / Lady Batterie

Delivery: 1,5 V | LR1 / N / Lady Battery

Livraison avec: 1,5 V | LR1 / N / Lady Pile

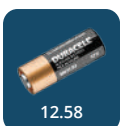

K Kantentaster elektronisch 3D

Edge finders electronic 3D
Palpeurs d'angle électroniques 3D



Verwendung:
Ausrichten von Werkstück-Bezugsflächen oder Kanten. Bestimmen von Bohrungsmittelpunkten zentrisch zur Arbeitsspindel.

Application:
Alignment of component reference surfaces or edges. Determination of bore centres to the machine spindle.

Usinage:
Pour aligner les surfaces ou les arêtes. Détermination du point de perçage centré par rapport à la broche de travail.

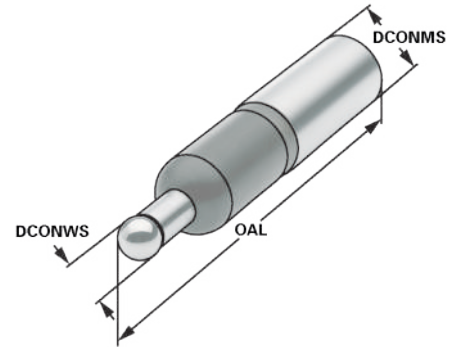

Bestell-Nr. Order no. Référence	DCONMS	OAL	DCONWS
702.3.16	16	110	10
702.3.20	20	106	10

- Ausführung:** Federnd gelagerte Tastkugel schützt das Gerät vor Beschädigung, falls zu stark angefahren wird. Funktionsteile gehärtet und geschliffen. Rundlauf-Genauigkeit: $\pm 0,01$ mm.
- Version:** *The spring-mounted spherical tip protects the unit from damage if contact is too strong. Functional parts hardened and ground. Concentricity: ± 0.01 mm.*
- Version:** La bille de palpation montée sur le ressort protège l'appareil contre les dégâts en cas de contact trop fort. Pièces de fonctionnement trempées et rectifiées. Précision de concentricité: $\pm 0,01$ mm.
- Funktion:** Bei Kontakt von Tastkugel und metallischem Werkstück bringen Batterien die Lampe zum Leuchten = Erkennen des Bezugspunktes.
- Function:** *When contact between the spherical tip and metal component occurs, the control lamp lights up = identification of the reference point.*
- Fonction:** Lorsque la bille de palpation entre en contact avec une pièce métallique, la lampe s'allume. = identification du point de référence.
- Lieferumfang:** 1,5 V | LR1 / N / Lady Batterie
- Delivery:** 1,5 V | LR1 / N / Lady Battery
- Livraison avec:** 1,5 V | LR1 / N / Lady Pile

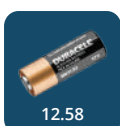

Edge finders electronic 3D

Palpeurs d'angle électroniques 3D



Verwendung:

Ausrichten von Werkstück-Bezugsflächen oder Kanten. Bestimmen von Bohrungsmittelpunkten zentrisch zur Arbeitsspindel.

Application:

Alignment of component reference surfaces or edges. Determination of bore centres to the machine spindle.

Usinage:

Pour aligner les surfaces ou les arêtes. Détermination du point de perçage centré par rapport à la broche de travail.

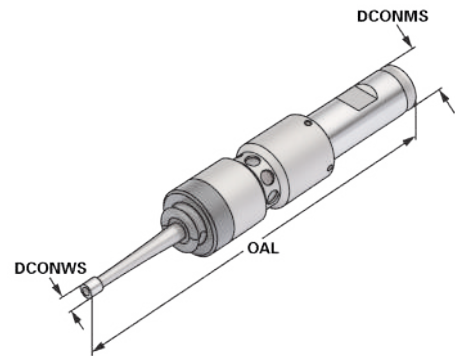

Bestell-Nr.
Order no.
Référence

702.6.20

DCONMS

20

LF

54

OAL

173

DCONWS

6

Ausführung: Der Tastkopf ist über eine Feder mit dem Einspannschaft elastisch verbunden und ermöglicht eine Ausricht-Genauigkeit von 0,01 mm. Alle Teile ganz gehärtet und geschliffen.

Version: *The contact point has a flexible connection to the body via a spring, with an alignment accuracy of 0.01 mm. All parts fully hardened and ground.*

Version: La tête de palpation est fixée de façon élastique avec la tige de fixation par un ressort. Cela permet la précision du réglage de 0,01 mm. Toutes les pièces sont entièrement trempées et rectifiées.

Funktion: Bei Kontakt mit dem metallischen Werkstück bringen Batterien die Lampe zum Leuchten = Erkennen des Bezugspunktes.

Function: *When contact with the metal component occurs, the control lamp lights up = identification of the reference point.*

Fonction: Lorsque la bille de palpation entre en contact avec la pièce métallique, la lampe s'allume = identification du point de référence.

Lieferumfang: 1,5 V | LR1 / N / Lady Batterie

Delivery: 1,5 V | LR1 / N / Lady Battery

Livraison avec: 1,5 V | LR1 / N / Lady Pile

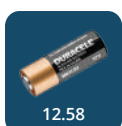

12.58

K Kantentaster mechanisch 3D

Edge finders mechanical 3D
Palpeurs d'angle mécanique 3D



Verwendung:
Zum Werkstück-Nullpunkt suchen und setzen in 3 Achsen x,y und z.

Application:
Search for the neutral point and raise in 3-axis, x, y and z.

Usiange:
Cherche le point zéro de la pièce et le positionne sur 3 axes x, y et z.

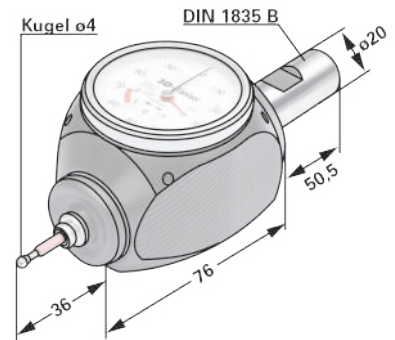

Bestell-Nr. Order no. Référence	Abmessung Size Dimension	DCONMS	OAL
702.7.20	3D 20 - 4 - 162,50	20	162,50

Ausführung: Mit dem Kantentaster, die als Nullpunkt vorgesehene Werkstückkante in x- oder y-Richtung anfahren, bis beide Zeiger der Meßuhr auf Null stehen, dann ist die Antastkante gleich der Spindelachse. In z-Richtung direkte Wegmessung. IP 67 spritzwassergeschützt

Version: Raise the tool edge assigned as neutral point in x- or y-way with the edge sensor until both pointers of the dial gage are at zero. At that moment the key-edge is equal to the spindle-axis. In z-way direct way-measurement. IP 67 waterproof

Version: Relevez l'arête d'outil définie comme le point neutre dans le sens x ou y avec le capteur d'arête jusqu'à ce que les deux pointeurs du comparateur soient à zéro. À ce moment-là, le bord de la clé est égal à l'axe de la broche. Vers le sens z la mesure directe IP 67 contre les projections d'eau

Ersatz Tasteinsatz

Substitute probe tip
Pièce de rechange de palpeur

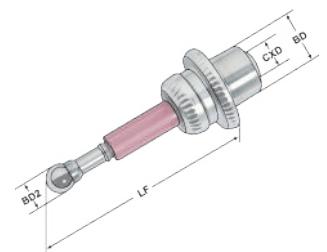

Bestell-Nr. Order no. Référence	BD2	LF	CXD	BD
ERS.702.7.20.001	4	27	M3	7,5
ERS.702.7.20.002	8	69	M3	7,5

Edge finders mechanical 3D
 Palpeurs d'angle mécanique 3D



Verwendung:
 Zum Werkstück-Nullpunkt
 suchen und setzen in 3 Achsen
 x,y und z.

Application:
 Search for the neutral point and
 raise in 3-axis, x, y and z.

Usinage:
 Cherche le point zéro de la
 pièce et le positionne sur 3 axes
 x, y et z.



Bestell-Nr. Order no. Référence	Abmessung Size Dimension	DCONMS	OAL
702.8.12	3D 12 - 3 - 132,5	12	132,5

Ersatz Tasteinsatz

Substitute probe tip
 Pièce de rechange de palpeur

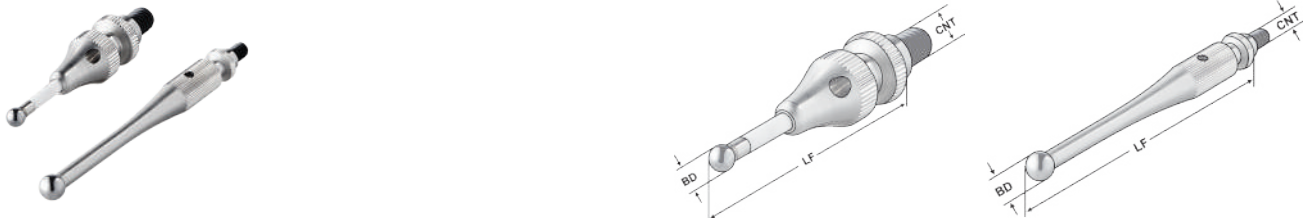

Bestell-Nr. Order no. Référence	BD	LF	CNT
ERS.702.8.12.01	3	27	M4
ERS.702.8.12.02	6	65	M4

K Null-Einstellgeräte mit Magnet

Z-Axis Zero-setters with magnet
Appareils de réglage du zéro avec aimant

Referenzhöhe / Hight / Hauteur 50 mm



Verwendung:
Zum Einstellen der Werkzeuge (z. B. Fräser) auf Null und zum Bestimmen des Referenzpunktes der Maschinenspindel.

Application:
For setting tools (e.g. end mills) to "zero" and for determining the reference point of the machine spindle.

Usiange:
Pour la mise à zéro d'outils (p. ex. fraiseuses) et pour pouvoir déterminer le point de référence de la broche de la machine.

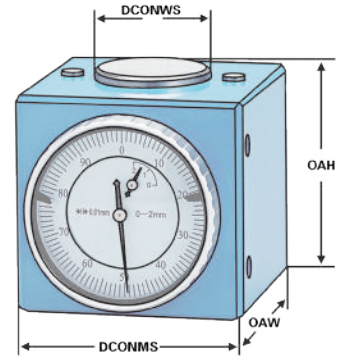

Bestell-Nr.
Order no.
Référence

702.5.48.2

Mit Magnet
with magnet
avec aimant

OAL

52

OAW

52

OAH

50

DCONWS

25

Null-Einstellgeräte ohne Magnet

Z-Axis Zero-setters without magnet
Appareils de réglage du zéro sans aimant

Referenzhöhe / Hight / Hauteur 50 mm



Verwendung:
Zum Einstellen der Werkzeuge (z. B. Fräser) auf Null und zum Bestimmen des Referenzpunktes der Maschinenspindel.

Application:
For setting tools (e.g. end mills) to "zero" and for determining the reference point of the machine spindle.

Usiange:
Pour la mise à zéro d'outils (p. ex. fraiseuses) et pour déterminer le point de référence de la broche de la machine.

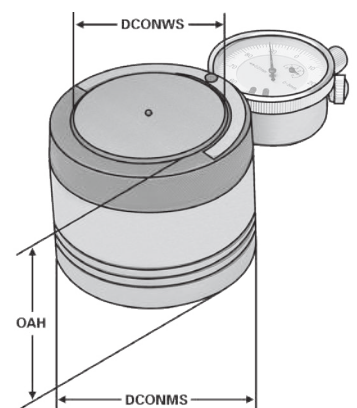

12

Bestell-Nr.
Order no.
Référence

702.5.48.1

Ohne Magnet
without magnet
avec aimant

DCONMS

62

OAH

50

DCONWS

25

Electronic Z-Axis Zero-setters with magnet

Appareils de réglage du zéro électronique avec aimant

Referenzhöhe / Hight / Hauteur 50 mm



Verwendung:

Zur Lagebestimmung von Werkstückoberflächen oder Werkzeuglängen in Z-Richtung auf Dreh- oder Fräsmaschinen.

Application:

To determine position of workpiece surfaces or workpiece lengths in Z-direction on lathes or milling machines.

Usinage:

Pour déterminer la position des surfaces des pièces ou les longueurs de pièces dans le sens Z sur les machines de tournage et de fraisage

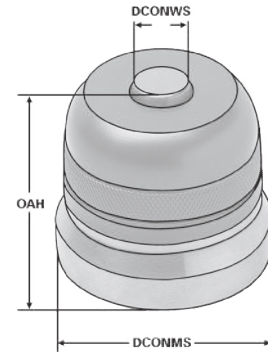

Bestell-Nr.
Order no.
Référence

DCONMS

OAH

DONWS

702.4.19

54

50

14

Funktion:

Das Gerät wird auf das Werkstück gestellt. Mit der Spindel fährt man nun vorsichtig auf das Gerät auf. Sobald die LED aufleuchtet hat man das Bezugsmaß 50 mm erreicht. Ein Sicherheitsfederweg von ca. 3 mm zum Überfahren der 50 mm ist eingebaut.

Function:

The apparatus is placed on the workpiece. With the spindle, now move carefully to the device. As soon as the LED lights up, you have achieved the reference value 50 mm. A safety spring way of approx. 3 mm to cross 50 mm is integrated.

Fonction:

Posez l'appareil sur la pièce de travail. Déplacez prudemment sur l'appareil avec la broche. Dès que la LED s'allume, la cote de référence a atteint 50 mm. L'appareil est équipé d'une voie de sécurité de débattement d'environ 3 mm pour pouvoir dépasser la limite de 50 mm.





Spannkraft-Prüfgerät für Hydrodehnspannfutter

Clamping force proofing instrument for hydraulic chucks

Appareil de contrôle des forces de serrage pour mandrin expansibles hydrauliques



Bestell-Nr. Order no. Références	Abmessung Size Dimension
M.800.H06	6mm
M.800.H08	8mm
M.800.H10	10mm
M.800.H12	12mm
M.800.H14	14mm
M.800.H16	16mm
M.800.H18	18mm
M.800.H20	20mm
M.800.H25	25mm
M.800.H32	32mm

Verwendung:

Präzise, schnelle und einfache Spannkraftmessung bei Hydraulik-Dehnspannfuttern

- mobile Messung auch innerhalb von Maschinen und Vorrichtungen
- Spannkraftermittlung über drucksensiblen Messdorn
- Anzeige als absoluter Messwert oder prozentuale Spannkraft relativ zum Referenzwert

Application:

Accurate, quick and simple measuring of the clamping force of hydraulic chucks

- mobility allows measuring within machines and fixtures*
- determines clamping force via a pressure sensitive plug gauge*
- display of absolute measuring value or percentage clamping force in relation to reference*

Usinage:

Mesure facile, rapide et précis des forces de serrage des mandrins hydrauliques

- mesure direct sur dispositifs et machines
- résultat de mesure d`un capteur cylindrique sensible aux pressions exercées
- Affichage de la valeur de mesure absolue ou de la force de serrage en pourcentage par rapport à la valeur sur laquelle on se réfère



K Datenverbindungskabel - 2 Meter

Data connection cable - 2 meter
Câble de connexion de données - 2 mètre



Bestell-Nr. Order no. Références	Schnittstelle PC Interface PC Interface PC	Schnittstelle Messmittel Interface measuring device Pour mesurer l'interface	Daten Data Données
M.900.05.4	USB-A	Micro-USB-B	Punkt Dot Point
M.900.05.5	USB-A	Micro-USB-B	Komma Comma Virgule





Bestell-Nr. Order no. Références	Schnittstelle PC Interface PC Interface PC	Schnittstelle Messmittel Interface measuring device Pour mesurer l'interface	Daten Data Données
M.900.07.0	USB-A	Typ D1	Punkt Dot Point
M.900.07.1	USB-A	Typ D1	Komma Comma Virgule



Bestell-Nr. Order no. Références	Schnittstelle PC Interface PC Interface PC	Schnittstelle Messmittel Interface measuring device Pour mesurer l'interface	Daten Data Données
M.900.10.0	USB-A	EIA RS-453 / IEC 60603-11	Punkt Dot Point

Wireless
Sans fil



Bestell-Nr. Order no. Références	Daten Data Données	Funktion Function Fonction	Frequenz Frequency Fréquence	
M.901.00.4	Punkt Dot Point	Ausgang (Micro-USB-B) Output (Micro-USB-B) Sortie (Micro-USB-B)	2,4G	
M.901.00.3	Punkt Dot Point	Eingang (USB-A) Input (USB-A) Accès (USB-A)	2,4G	

Batterien

Batteries
Batteries



Bestell-Nr. Order no. Références	Abmessung Size Dimension
M.CR2032	Batterie Battery Pile - 3 V CR2032
M.LR44	Batterie Battery Pile - 1,5 V LR44
M.B.MN21	Batterie Battery Pile - 12 V A23 / 23A / MN21
M.B.LR1	Batterie Battery Pile - 1,5 V LR1 / N / Lady

TECHNISCHE DATEN
TECHNICAL DATA
DONNÉES TECHNIQUES

KEMMLER
Präzisionswerkzeuge

Online-Shop
Information über Preise und Verfügbarkeit „Auch
am Die Leih“

Technische Daten

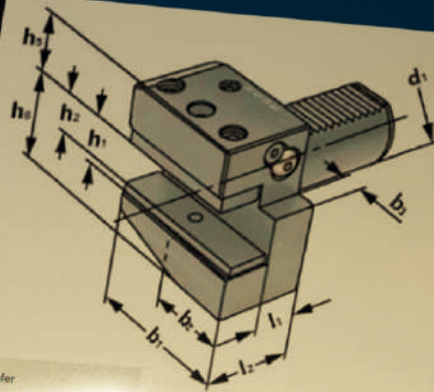

Kemmler
Präzisionswerkzeuge

Tel. +49 7473 924080
Fax +49 7473 9240820
info@kemmler-tool.de

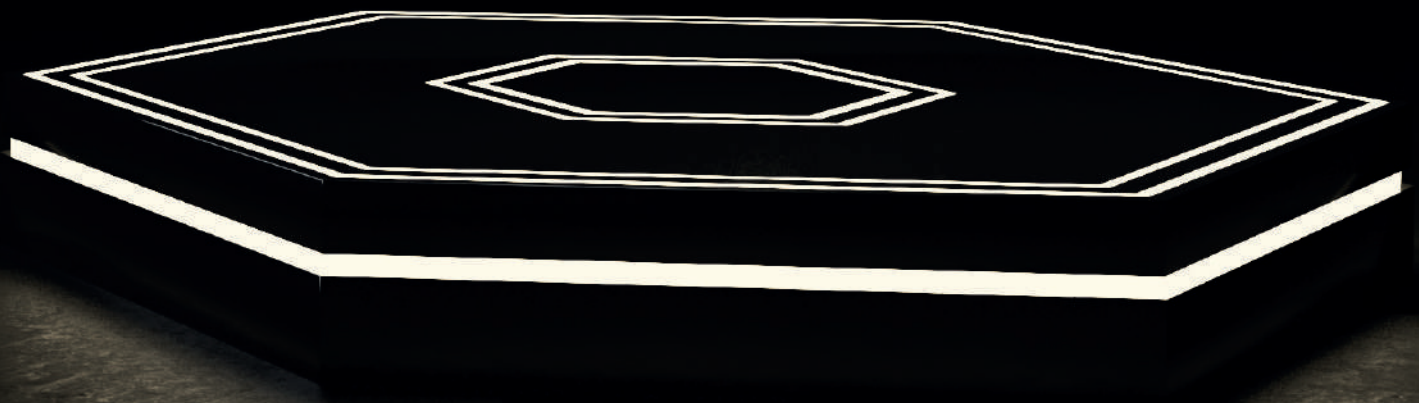



Steilkegel-Aufnahmen _____	13.05	
Anzugsbolzen _____	13.06	
HSK (Hohlschaftkegel) _____	13.07	
Übersicht HSK-Schäfte _____	13.09	
HSK-Kühlmittelübergabeeinheiten _____	13.10	
Unwuchteinflüsse auf Maschinenspindeln		
Werkzeugaufnahmen und Werkzeuge _____	13.11	
Hydro-Dehnspannfutter _____	13.13	
Bedien- und Gebrauchsanleitung für Hydro-Dehnspannfutter _____	13.14	
Drehmoment zum Spannen von Weldon-Fräsern _____	13.15	
Bedien- und Gebrauchsanleitung für CNC-Bohrfutter _____	13.16	
Montageanleitung für Spannzangen ISO 15488 (DIN 6499) _____	13.17	
Montageanleitung für Dichtscheiben _____	13.18	
Gewindeschneidschnellwechselfutter _____	13.19	
Technische Hinweise für Gewindeschneidschnellwechselfutter _____	13.20	
Gewindebohrer-Schaftmaße _____	13.21	
Werkzeugzuordnung für Scheibenrevolver _____	13.22	
Präzisions-Spannzangenfutter System KPS _____	13.23	
Hochleistungs-Kraftspannfutter System HKS _____	13.25	
Präzisions-Spannzangenfutter ER _____	13.27	
Laserbeschriftung der Werkzeuge - KEMMLER OEM - _____	13.28	
Der Kemmler-Nummernschlüssel _____	13.29	
ISO-Bezeichnungssystem _____	13.30	
Index _____	13.32	
Table de matières _____	13.60	



Die Maschinenspindeln bei manuellen oder CNC-Maschinen sind mit präzise geschliffenen Innenkegeln versehen, in die die entsprechenden Werkzeugaufnahmen aufgenommen werden. Die Werkzeugaufnahmen werden mit einem Anzugsbolzen oder Gewindestange in die Maschinenspindel eingezogen. Bei CNC-Maschinen erfolgt der Werkzeugeinzug automatisch über einen Anzugsbolzen.

Ein Werkzeughalter besteht aus fünf Grund-Komponenten:

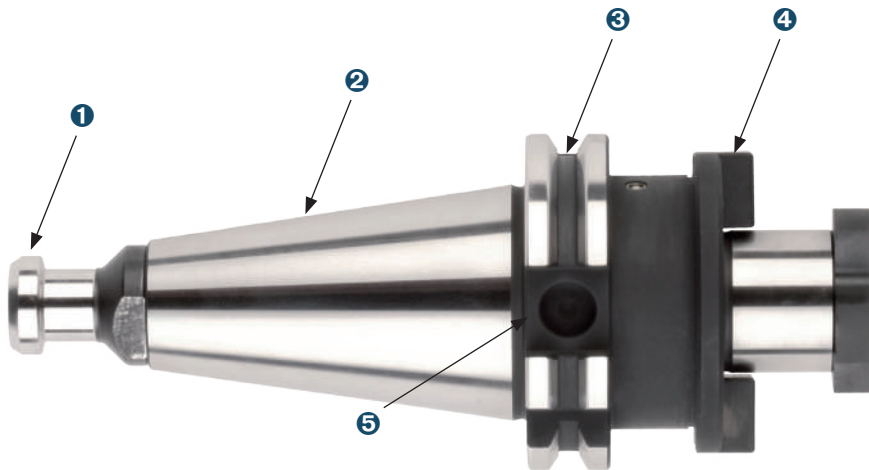

- ① Anzugsbolzen
- ② Kegelschaft
- ③ Greiferrille: umlaufende V-Nut
- ④ Adapter - Werkzeugaufnahme
- ⑤ Mitnahme-Nut

Kegelschaft

Der Standard definiert sechs grundlegende Kegelschaft-Größen SK 30, SK 35, SK 40, SK 45, SK 50 und SK 60.

Der passende Kegelschaft für den Maschinentyp

- SK 60 Sehr große Maschinen
- SK 50 Mittlere Maschinen
- SK 40 Kleine Maschinen
- SK 30 Sehr kleine Maschinen

Kühlmitteleinlass Form AD/B

Aufnahmen Form AD/B haben Innenkühlung. Bei Form B (Kühlmitteleinlass durch den Bund) müssen die beiden Gewindestifte entfernt und ein nicht durchbohrter Anzugsbolzen eingesetzt werden. Bei Form AD (zentrale Kühlmitteleinlass) müssen die beiden Gewindestifte im Bund verbleiben und ein Anzugsbolzen mit Bohrung eingesetzt werden.

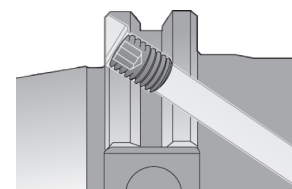



Anzugsbolzen sind ein wichtiges Bindeglied zwischen Maschine und Werkzeug. Der Anzugsbolzen erlaubt es dem Spanngreifer der Spindel den Werkzeughalter fest in die Spindel zu ziehen und ihn automatisch auszuwerfen.

Anzugsbolzen gibt es in verschiedenen Ausführungen und Größen. Sie sind nicht untereinander austauschbar. Neben den Anzugsbolzen gemäß DIN ISO 7388-3 (früher DIN 69872) gibt es eine Vielzahl an Werksnormen die vom jeweiligen Maschinenwerkzeughersteller spezifiziert wurden.

Verwendung:

- Für Werkzeuge mit Steilkegelschaft ISO 7388-1 und ISO 7388-2 [früher DIN 69871 und JIS B 6339 (MAS-BT)]
- In Bearbeitungszentren (Maschinen mit automatischem Werkzeugwechsler)
- In NC-Maschinen (Maschinen ohne automatischem Werkzeugwechsler)
- für Werkzeuge mit axialer Kühlmittelzufuhr
- für Werkzeuge ohne bzw. mit axialer Kühlmittelzufuhr

Nur Anzugsbolzen verwenden, die vom Maschinenwerkzeughersteller spezifiziert wurden.

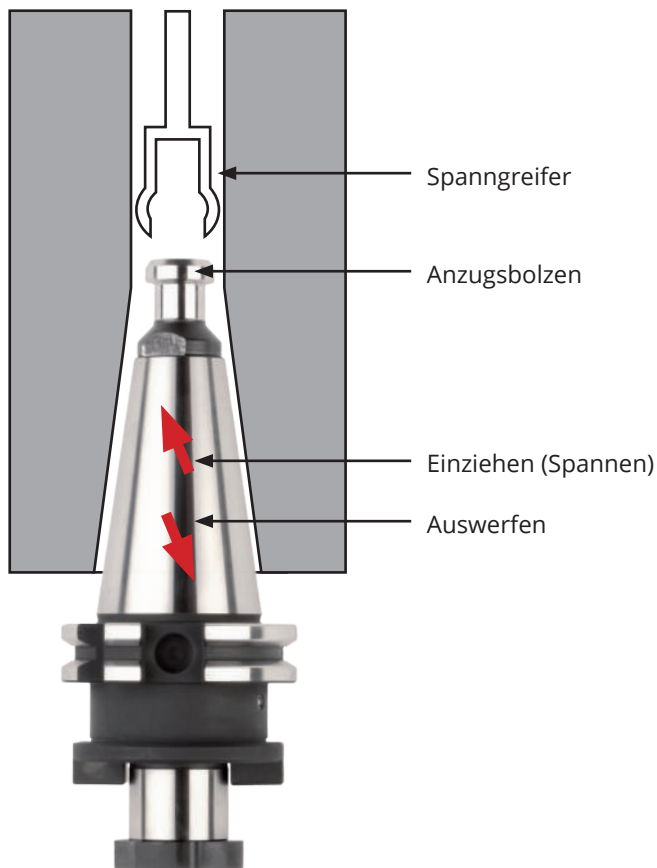

Empfohlenes Anzugsmoment für Montage der Anzugsbolzen:

SK / BT / ISO 30	20 Nm
SK / BT / ISO 40	50 Nm
SK / BT / ISO 50	100 Nm



Normative Verweise:

DIN ISO 7388 besteht unter dem Haupttitel „Werkzeugschäfte mit Kegel 7/24 für automatischen Werkzeugwechsel“ aus den folgenden Teilen:

- Teil 1: Maße und Bezeichnung von Schäften der Formen A, AD, AF, U, UD und UF
- Teil 2: Maße und Bezeichnung von Schäften der Formen J, JD und JF
- Teil 3: Anzugsbolzen für Schäfte der Formen AC, AD, AF, UC, UD, UF, JD und JF

DIN ISO 7388-3

Werkzeugschäfte mit Kegel 7/24 für automatischen Werkzeugwechsel – Teil 3: Anzugsbolzen für Schäfte der Formen AC, AD, AF, UC, UD, UF, JD und JF (ISO 7388-3:2013)

DIN ISO 7388-3 ist Ersatz für DIN 69872:1988-07



HSK-Werkzeughalter DIN 69893

Der Hohlschaftkegel (HSK) hat sich seit der Normung als Schnittstelle zwischen Maschine und Werkzeug durchgesetzt.

HSK bietet folgende Vorteile:

- Hohe statische und dynamische Steifigkeit
- Hohe Drehmomentübertragung und definierte radiale Positionierung
- Hohe Wechsel- und Wiederholgenauigkeit
- Hochgeschwindigkeitstauglichkeit
- Kurze Wechselzeiten
- Codierung bzw. Identifizierung
- Kühlmittelzufuhr

Wuchtempfehlung und Grenzdrehzahlen

Kemmler HSK-Aufnahmen sind grundsätzlich vorgewuchtet auf G 6,3 15.000 min⁻¹.

Auf Kundenwunsch ist ein feinwuchten auf höhere Wuchtgüten möglich.

Da die Drehzahl letztendlich den größten Einfluss hat, und auch von der Schnittstelle Spindel bzw. Spindellagerung Grenzen vorliegen, wurden im Rahmen der HSK-Normung folgende Grenzdrehzahlen für die HSK-Schnittstellen als Richtwerte empfohlen:

- HSK-A/C 32 bis 30.000 min⁻¹
- HSK-A/C 40 bis 30.000 min⁻¹
- HSK-A/C 50 bis 30.000 min⁻¹
- HSK-A/C 63 bis 25.000 min⁻¹
- HSK-A/C 80 bis 20.000 min⁻¹
- HSK-A/C 100 bis 16.000 min⁻¹

Abhängig vom Werkzeug kann es bei diesen maximalen Drehzahlen notwendig sein, die Werkzeugaufnahme und das Werkzeug gemeinsam zu wuchten. Klare Grenzwerte können nur unter Berücksichtigung der Maschinen- oder Spindelausführung und bei definierten Werkzeugen mit Auskräglängen bestimmt werden.

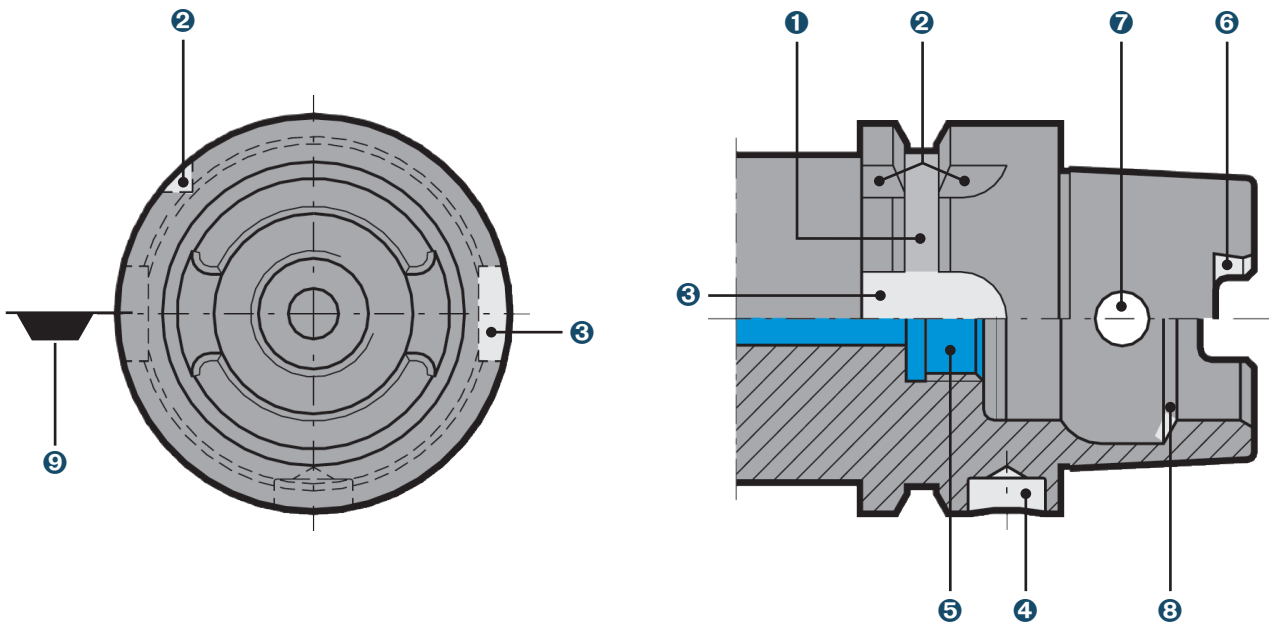

Begriffserklärung an HSK-A-Werkzeugaufnahmen

- ❶ Greiferrille: umlaufende V-Nut
- ❷ Positionskerbe quer zur Greiferrille (dient zur Indexierung)
- ❸ Mitnehmernut am Bund: Zur Indexierung oder zur Aufnahme in einem Werkzeugmagazin oder Greifer. Bei HSK-B/D gleichzeitig zur formschlüssigen Drehmomentübertragung zur Spindel.
- ❹ Codierbohrung: zur Aufnahme eines Datenträgers (Codierchip) im Bund
- ❺ Anschlussgewinde für Kühlmittelübergabeeinheit: zur Aufnahme des Kühlmittelrohrs
- ❻ Mitnehmernut am Kegelschaft: formschlüssige Drehmoment-Kegelschaft übertragung zur Spindel
- ❼ radiale Zugriffsbohrung im Kegelschaft: zur Betätigung manueller Spannsysteme
- ❽ Spanschulter: Ringfläche, an der das Werkzeug eingezogen wird
- ❾ Lage der Werkzeugschneide bei einschneidigen Werkzeugen



DIN 69063-1 (ISO 12164-1) Form A

Standard-Typ für Bearbeitungszentren und Fräsmaschinen. Hohlenschaftkegel für automatischen Werkzeugwechsel mit Greif- und Indexiernut. Manuelle Betätigung durch Zugriffsbohrung im Kegel möglich. Aufnahmebohrung für Datenträger DIN STD 69873 im Flansch. Das Drehmoment wird kraft- und formschlüssig übertragen.

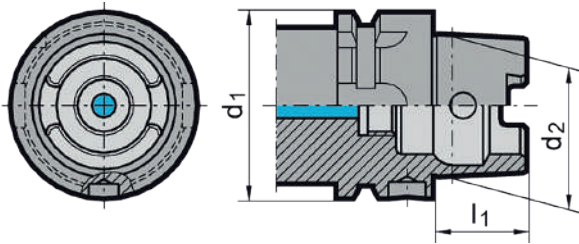

DIN 69063-2 (ISO 12164-1) Form B

Für Bearbeitungszentren, Fräs- und Drehmaschinen. Mit vergrößerter Flanschgröße für stabile Bearbeitung. Für automatischen Werkzeugwechsel. Kühlmittelversorgung durch den Flansch. Aufnahme für Datenträger DIN STD 69873 im Flansch.

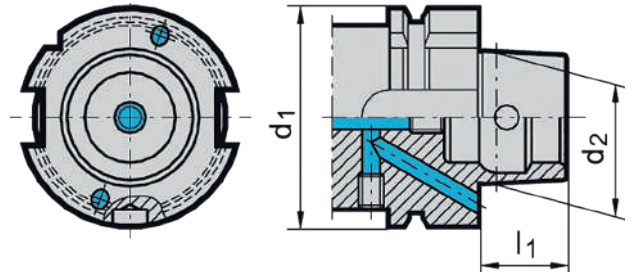

DIN 69063-1 (ISO 12164-1) Form C

Für Transferstraßen, spezielle Maschinen und modulare Werkzeugsysteme. Hohlenschaftkegel für manuellen Werkzeugwechsel. Betätigung durch Zugriffsbohrung im Kegel. Da alle Form A Halterungen mit Seitenlöchern für manuellen Werkzeugwechsel ausgestattet sind, können sie auch als Form C Halterungen verwendet werden. Das Drehmoment wird kraft- und formschlüssig übertragen.

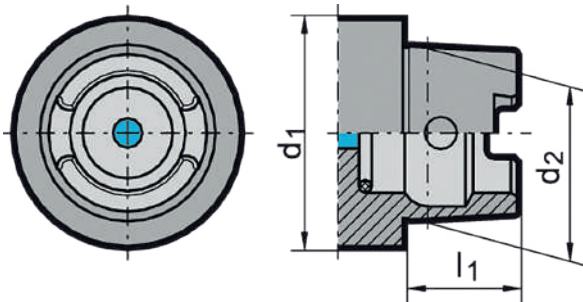

DIN 69063-2 (ISO 12164-2) Form D

Für spezielle Maschinen. Mit vergrößerter Flanschgröße für stabile Bearbeitung. Für manuellen Werkzeugwechsel. Kühlmittelversorgung durch den Flansch.

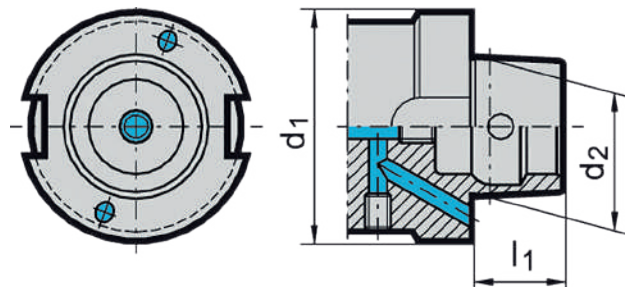

DIN 69063-5 Form E

Für Hochgeschwindigkeits-Bearbeitung. Hohlenschaftkegel für automatischen Werkzeugwechsel. Das Drehmoment wird kraftschlüssig übertragen. Ausführung mit Zugriffsbohrung nach DIN 69893-1 nach Vereinbarung.

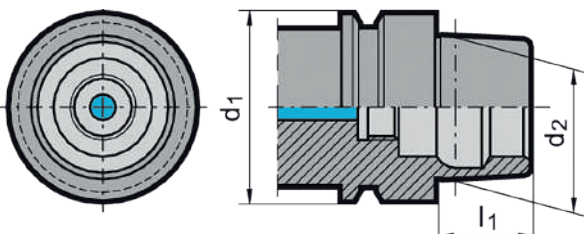

DIN 69063-6 Form F

Für Hochgeschwindigkeits-Bearbeitungen, hauptsächlich in der Holzverarbeitenden Industrie. Hohlenschaftkegel für automatischen Werkzeugwechsel. Mit vergrößerter Flanschgröße für stabile Bearbeitung. Das Drehmoment wird kraftschlüssig übertragen. Ausführung mit Zugriffsbohrung nach DIN 69893-1 nach Vereinbarung.

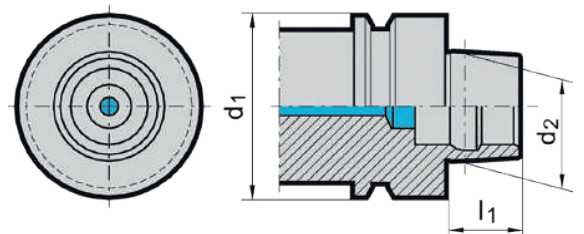



Bei Bearbeitung mit Innenkühlung müssen HSK-Aufnahmen Form A mit einem Kühlmittelrohr bestückt werden.

Werden Aufnahmen mit Innenkühlung ohne Kühlmittelübergabeinheiten eingesetzt kann dies zur Beschädigung der Spindel führen.

Für DIN 69893 Form C, -E und -F sind keine Kühlmittelrohre erforderlich.
Die zentrale Kühlmittelzufuhr bzw. Abdichtung erfolgt durch eine Spanneinheit.

Der Einbau des Kühlmittelrohres wird idealerweise in vertikaler Richtung – von unten nach oben – vorgenommen. Hierdurch soll verhindert werden, dass der Dichtring beim Einschrauben verrutscht, bzw. verdrückt wird und somit seine Abdichtfunktion verliert.

Das Kühlmittelrohr ist nach dem Einbau, gemäß DIN, minimal beweglich ($\pm 1^\circ$).

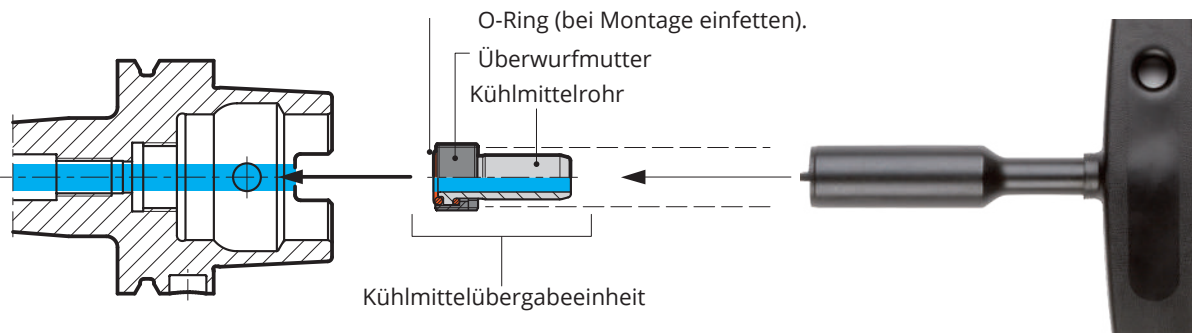

Montage

1. Die HSK-Aufnahme muss sauber und frei von Spänen und Beschädigungen sein.
2. Die O-Ringe vor Montage einfetten.
3. Den Kühlmittelübergabe-Satz vollständig (Kühlmittelrohr, Überwurfmutter und 2 O-Ringe) mit Hilfe des Steckschlüssels zentrisch in den HSK einführen.
4. Den Kühlmittelübergabe-Satz/die Kühlmittelübergabe-Einheit einschrauben und fest anziehen. (Drehmoment s. Tabelle rechts)
5. Das Kühlmittelrohr auf radiale Beweglichkeit prüfen.

Drehmoment

für HSK	Mt (Nm)
32	7
40	11
50	15
63	20
80	25
100	30

K Unwuchteinflüsse auf Maschinenspindeln, Werkzeugaufnahmen und Werkzeuge



Die Unwucht

Eine Unwucht erzeugt bei der sich drehenden Spindel eine Fliehkraft, die die Lauf-
ruhe des Werkzeugs stört. Diese Unwucht hat Einfluss auf den Arbeitsprozess und die
Lebensdauer des Spindellagers. Die Fliehkraft F wächst linear mit der Unwucht U und
quadratisch mit der Drehzahl nach untenstehender Formel.

Auswuchten

Um unerwünschte Fliehkraften auszugleichen, muss die symmetrische Massenver-
teilung wiederhergestellt werden, mit dem Ziel, dass auf die Spindellagerung keine
Fliehkraften wirken. Bei Werkzeugaufnahmen sind Ausgleichsbohrungen oder -flächen
üblich. Dadurch tendiert die Summe aller auf die Achse wirkenden Fliehkraften gegen
Null
(s. DIN ISO 1940).

Schwerpunktverlagerung

Durch die Unwucht einer Welle wird deren Schwerpunkt aus der Drehachse um
einen Abstand in Richtung der Unwucht verlagert. Dieser Schwerpunktabstand wird
auch Restexzentrizität e oder Schwerpunktverlagerung genannt. Je größer die
Wuchtkörpermasse m ist, desto größer kann die zulässige Restunwucht U sein.

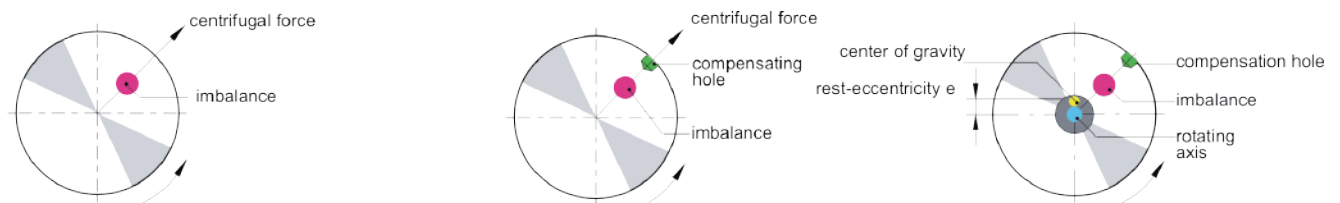

Unwuchtberechnung

Die Unwucht ist ein Maß, das angibt, wieviel unsymmetrisch verteilte Masse in radialer
Richtung von der Drehachse entfernt ist. Die Unwucht wird in gmm angegeben.
Das Abstandmaß e sagt aus, wie weit der Schwerpunkt eines Teils von der Drehachse
entfernt ist.

Die Unwucht ergibt sich aus:

$$U = m \times r$$

U = Unwucht in gmm

e = Schwerpunktabstand in μm

m = Masse in kg



Wuchtgrenzen

Entsprechend DIN ISO 1940 wird die Auswuchtgüte mit G sowie den Einheiten gmm/kg bzw. μm bezeichnet und ist drehzahlbezogen. Bei einer Drehzahl von 15.000 U/min und einem Gewicht von 1 kg entspricht G 6,3 einem zulässigen Mittenversatz zwischen Rotationsachse und Schwerpunktachse der Spindel von 4 μm . Bei doppelter Drehzahl von 30.000 U/min wären es 2 μm . Wiegt der Werkzeughalter nur noch die Hälfte, also 0,5 kg, halbiert sich auch die zulässige Auswuchtteranz. Ziel des Auswuchtens muss es sein, einen Kompromiss zwischen dem technisch Machbaren und dem wirtschaftlich Sinnvollen zu finden. Da die radiale Wechselgenauigkeit bei einer fabrikneuen HSK-Aufnahme bereits 2 bis 3 μm und bei einer SK-Aufnahme bereits 5 bis 10 μm betragen kann, bedeutet das bereits eine Qualitätsgrenze von G 2,5 bzw. G 6,3 bei 10.000 U/min.

Die nachstehende Grafik zeigt die Gütestufen nach DIN ISO 1940-1, also die zulässigen, auf die Wuchtkörpermasse bezogene Restunwuchten für verschiedene Auswuchtgüten G in Abhängigkeit von der höchsten Betriebsdrehzahl.

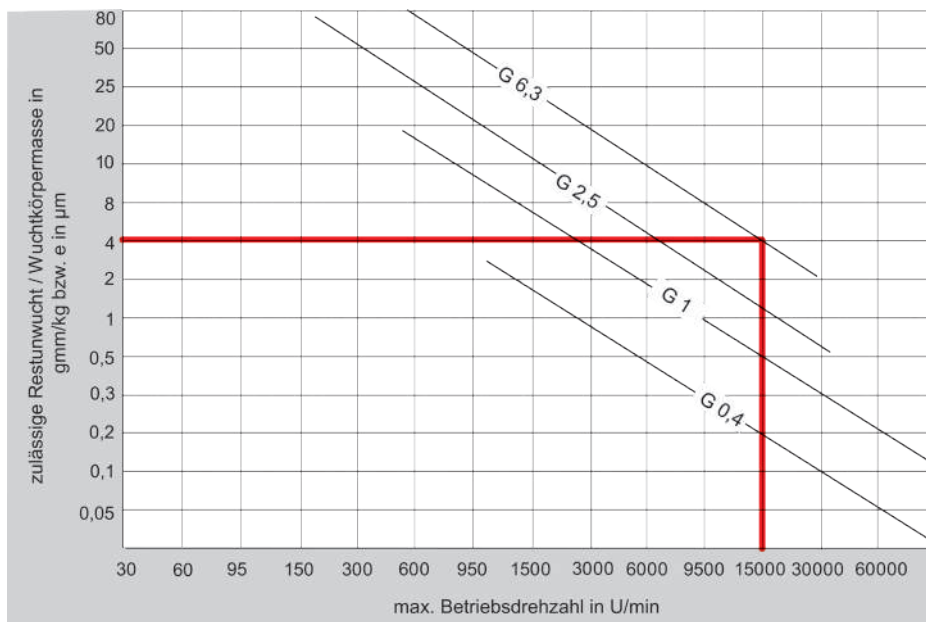

KEMMLER Werkzeugaufnahmen werden auf G 6,3 / 15.000 U/min gewuchtet.

Feingewuchtet durch Bohrungen in der Greiferrille

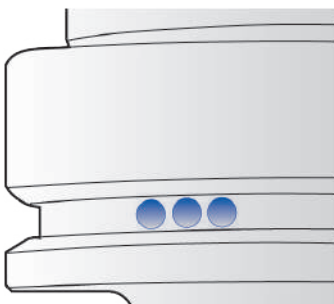

Vorgewuchtet durch Wuchtbohrungen am Bund

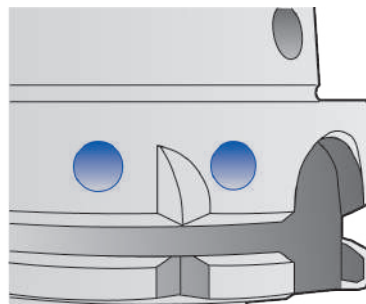

Vorgewuchtet durch Wuchtfläche am Werkzeukörper

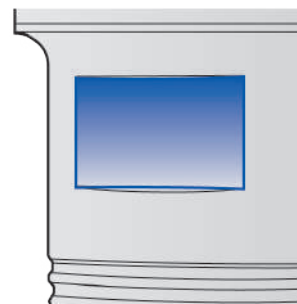



Moderne Zerspanungsprozesse stellen besondere Anforderungen an die Werkzeugaufnahme. Hydraulik-Dehnspannfutter bieten deshalb guten Halt, verbunden mit einem exakten Rundlauf. Zudem ermöglichen sie einen leichten und schnellen Werkzeugwechsel.

Durch Drehen der Druckschraube entsteht in der Druckkammer ein ausreichend hoher Druck, der zur elastischen Verformung der Dehnspannhülse führt, wodurch das Werkzeug kraftvoll gespannt wird – und das bei exaktem Rundlauf. Dies sorgt für einen sicheren und kraftschlüssigen Sitz. Werden Reduzierbuchsen, die unterschiedliche Werkzeugdurchmesser aufnehmen können, benutzt, dann lässt sich der Werkzeugeinsatz beliebig erweitern.



Vorteile

- Präzise Werkzeugspannung bei maximal 3 µm Rundlauffehler
- Übertragung hoher Drehmomente durch optimiertes Dehnhülensystem (hohe Spannung)
- Hochgeschwindigkeitstauglich (keine Fliehkräfte durch Spannsegmente)
- Exakter Rundlauf, dadurch hervorragende Oberflächengüte und Maßhaltigkeit am Werkstück
- Rascher Werkzeugwechsel mittels leicht betätigbarer Spannschraube
- Optimale Werkzeugstandzeiten
- Vibrationsdämpfende Wirkung durch Hydro-Polster

Technische Daten

Spann- Ø [mm]	Anzugs- drehmoment [Nm]	Mindest- Einspanntiefe [mm]	Zul. Übertragbares Drehmoment bei Schaft Kleinstmaß h6 [Nm]	Toleranz des Schaftwerk- zeuges	Max. Drehzahl [min ⁻¹]	
					LPR ≤ 125 mm	LPR > 125 mm
6	10	27	12	h6	40.000	20.000
8	10	27	30	h6	40.000	20.000
10	10	31	40	h6	40.000	20.000
12	10	36	70	h6	40.000	20.000
14	10	36	100	h6	40.000	20.000
16	10	39	135	h6	40.000	20.000
18	10	39	180	h6	40.000	20.000
20	10	41	220	h6	40.000	20.000
25	10	47	500	h6	20.000	10.000
32	10	51	700	h6	20.000	10.000

Verwendbare Schafttypen

DIN 6535 DIN 1835-1	Ø 6 - 20 mm	Ø 25 - 32 mm	Spannung mit Hilfe von Reduzierbuchsen
 Form HA	✓	✓	✓
 Form HB/ E	✓	✗	✓
 Form HE/ E	✗	✗	✓
Rundlauf (↗)	≤ 0,003 mm		≤ 0,005 mm



Um eine fehlerfreie Funktion der Hydro-Dehnspannfutter zu gewährleisten, beachten Sie bitte folgende Anweisungen:

Verwendung von Zylinderschaftwerkzeugen nach DIN 1835 und DIN 6535 Form (HA) und B (HB) bis \varnothing 20 mm Spannschaft mit Herstelltoleranz h_6 , feingeschliffen $Ra_{min} = 0,3$.

Schäfte nach DIN 6535 Form HE (Whistle Notch) sind nur in Verbindung mit Reduzierstücken einsetzbar. Alle Hydro-Dehnspannfutter sind bis G 6,3 15.000 min⁻¹ ab Werk vorgewuchtet.

Spannen und Lösen eines Werkzeuges

1. Reinigen der Futteraufnahmebohrung und des Werkzeugschaftes von Fett und Schmutz. Werkzeugschaft bis zum Anschlag einführen. Mindesteinspannlänge und Verstellweg sind unbedingt einzuhalten.
2. Mit Sechskantquergriffschlüssel im Uhrzeigersinn die Spannschraube bis zum Anschlag drehen. Das Werkzeug ist gespannt. Wegen Bruchgefahr der Dehnspannhülse keine Leerspannungen vornehmen.
3. Zum Lösen des Werkzeuges Spannschraube ca. 5 bis 6 Umdrehungen zurückdrehen und das Werkzeug entnehmen.

Hinweis: Niemals ohne eingespanntes Werkzeug spannen!

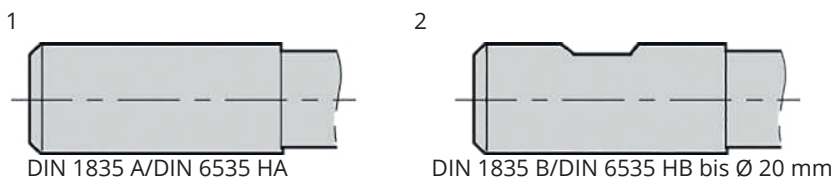

Reinigung

Auf Sauberkeit von Aufnahmebohrung und Werkzeugschaft achten.

Temperatur

Optimaler Temperaturbereich zwischen 10–50 °C. Bei Temperaturen über 80 °C nicht einsetzen.

Lagerung

Hydro-Dehnspannfutter entspannt, gereinigt und leicht eingeölt lagern.

Spannschäfte

Nur Werkzeugschäfte der DIN 1835 Form A und Form B (bis 20 mm) spannen.

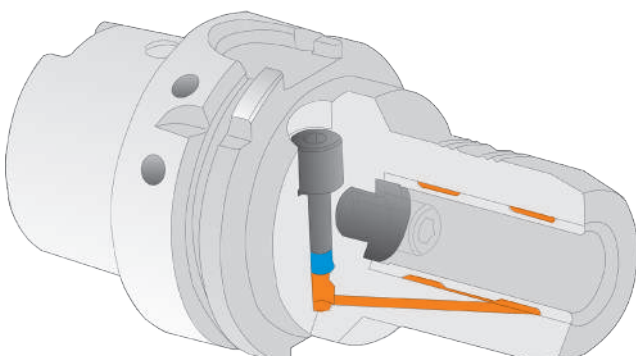



Höchste Rundlaufgenauigkeiten mit definierten Drehmomenten bei Weldon­schäften:



Drehmomente für DIN 1835

Bohrung	Schraube		Drehmoment
Ø 6 mm	M 6	SW 3	10 Nm
Ø 8 mm	M 8	SW 4	10 Nm
Ø 10 mm	M 10	SW 5	16 Nm
Ø 12 mm	M 12	SW 6	28 Nm
Ø 14 mm	M 12	SW 6	28 Nm
Ø 16 mm	M 14	SW 6	42 Nm
Ø 18 mm	M 14	SW 6	42 Nm
Ø 20 mm	M 16	SW 8	50 Nm
Ø 25 mm	M 18 × 2	SW 10	60 Nm
Ø 32 mm	M 20 × 2	SW 10	72 Nm
Ø 40 mm	M 20 × 2	SW 10	72 Nm
Ø 50 mm	M 24 × 2	SW 12	90 Nm
Ø 63 mm	M 24 × 2	SW 12	90 Nm

Die Belastungsgrenzen der Spindelaufnahme müssen eingehalten werden.

Betriebstemperatur: + 20 °C ... + 50 °C.

Max. Kühlmitteldruck: 80 bar.

Spann-Ø	max. Drehzahl in m^{-1}		Max. Anzugsmoment der Spannschraube	Spannschraube	SW	Schaft-Ø in mm
	LPR bis 125mm	LPR über 125mm				
Ø 6 mm	50.000	30.000	10 Nm	M 6	SW 3	Ø 6 h6
Ø 8 mm	50.000	30.000	10 Nm	M 8	SW 4	Ø 8 h6
Ø 10 mm	50.000	30.000	16 Nm	M 10	SW 5	Ø 10 h6
Ø 12 mm	50.000	30.000	28 Nm	M 12	SW 6	Ø 12 h6
Ø 14 mm	50.000	30.000	28 Nm	M 12	SW 6	Ø 14 h6
Ø 16 mm	50.000	30.000	42 Nm	M 14	SW 6	Ø 16 h6
Ø 18 mm	50.000	30.000	42 Nm	M 14	SW 6	Ø 18 h6
Ø 20 mm	50.000	30.000	50 Nm	M 16	SW 8	Ø 20 h6
Ø 25 mm	25.000	20.000	60 Nm	M 18 × 2	SW 10	Ø 25 h6
Ø 32 mm	25.000	20.000	72 Nm	M 20 × 2	SW 10	Ø 32 h6



Spannen und Lösen des Werkzeuges

Um eine fehlerfreie Funktion der CNC-Bohrfutter 08 / 13 / 16 zu gewährleisten beachten Sie bitte folgende Anweisungen:

Achtung:

Das Werkzeug darf nur bei stillstehender Spindel oder außerhalb der Maschine gespannt werden.

Das CNC-Bohrfutter (Pos. 1) wird mit einem Sechskantquergriffschlüssel (Pos. 3) seitlich über einen Kegeltrieb gespannt. Drehen Sie den Sechskantschlüssel im Uhrzeigersinn um das Bohrfutter zu spannen, im Gegenuhrzeigersinn um das Bohrfutter zu öffnen.

1. Schritt

Öffnen Sie die Spannbacken des Bohrfutters weit genug um das Schneidwerkzeug (Pos. 2) einzulegen.

2. Schritt

Das Werkzeug (Pos. 2) wird bis zum Anschlag in das CNC-Bohrfutter (Pos. 1) eingeführt. (Bild 1)

3. Schritt

Drehen Sie den Sechskantschlüssel (Pos. 3) mit einem Anzugsmoment von 15 Nm (bei 0,5-8 = 10 Nm) im Uhrzeigersinn, um das Werkzeug ordnungsgemäß zu spannen. (Bild 2)

Achtung:

Keine Verlängerung oder Anzughilfe verwenden. Bei einem Anzugsmoment größer 15 Nm (bei 0,5-8 = 10 Nm) kann der Kegeltrieb zerstört werden. Hierbei ist das Ritzel die Sollbruchstelle, um größere Beschädigungen am Bohrfutter zu verhindern.

4. Schritt

Überprüfen Sie nach dem Spannvorgang ob das Werkzeug zentrisch gespannt ist.

Achtung:

Keine konischen Schäfte spannen – Unfallgefahr!

5. Schritt

Das CNC-Bohrfutter ist betriebsbereit und kann in die Maschinenspindel eingespannt werden. (Bild 3)

6. Schritt

Zum Lösen des Werkzeuges drehen Sie den Sechskantschlüssel im Gegenuhrzeigersinn und entnehmen das Werkzeug.

Wartung und Reinigung

Die CNC-Bohrfutter 08 / 13 / 16 sind wartungsfrei, sollten aber nach dem Gebrauch mit Druckluft und einem sauberen Lappen gereinigt werden. Die Reinigung mit Lösungsmittel kann Korrosion verursachen. Daher das Bohrfutter vor dem Einlagern mit Öl einsprühen.

Reparatur

Im Reparaturfall bitten wir Sie das CNC-Bohrfutter an uns zurückzusenden. Wir tauschen dann grundsätzlich den kompletten Bohrfutterkopf aus.

Auf diese Weise erhalten Sie schnellstmöglich Ersatz und nur auf diese Weise kann ein ordnungsgemäßes Funktionieren der Bohrfutter und eine Rundlaufabweichung < 0,03 mm gewährleistet werden.



Bild 1



Bild 2



Bild 3



Montage:

Nut der Spannzange in den Exzenterring der Spannmutter einhängen. Spannzange in entgegengesetzte Richtung kippen, bis diese deutlich hörbar einrastet. Werkzeug einsetzen. Spannmutter mit der eingerasteten Spannzange auf das Gewinde des Spannfutters schrauben. Wir empfehlen, die Spannmutter mit einem Drehmomentschlüssel anzuziehen.

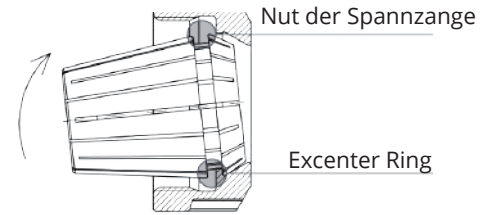

Demontage:

Nach dem Abschrauben vom Spannfutter auf die Frontseite der Spannzange drücken und gleichzeitig die Spannzange durch seitlichen Druck auf den hinteren Teil aus der Einrastung der Mutter herausnehmen.

Eine falsche Handhabung beeinträchtigt den Rundlauf der Spannzange und kann die Spannmutter beschädigen.

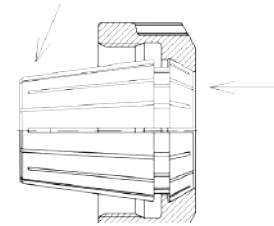

Achtung:

Nur Spannmuttern mit richtig eingerasteter Spannzange montieren!

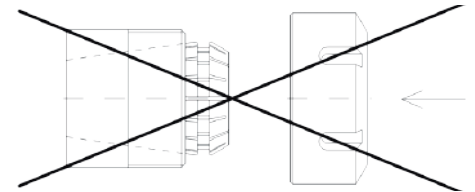

Niemals Schäfte mit Übermaß spannen!
z. B. niemals in eine Zange mit $\varnothing 12-11$ mm einen Schaft mit $\varnothing 12,2$ mm einpressen. Verwenden Sie jeweils die nächst grössere Spannzange (hier 13-12 mm).

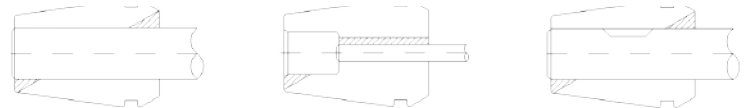

Werkzeugschaft möglichst auf der gesamten Länge der Spannzange spannen (mindestens jedoch 2/3 der Spannzangenlänge).



Maximales Drehmoment

ER 16	M22 × 1,5	50 Nm
ER 20	M25 × 1,5	75 Nm
ER 25	M32 × 1,5	85 Nm
ER 32	M40 × 1,5	105 Nm
ER 40	M50 × 1,5	150 Nm
ER 11 Mini	M13 × 0,75	18 Nm
ER 16 Mini	M19 × 1	28 Nm

Bitte beachten Sie das angegebene maximale Drehmoment.



Montage:

Die Dichtscheibe mit dem kleineren Durchmesser zuerst von innen in die Spannmutter einführen und den Druck gleichmäßig erhöhen bis die Dichtscheibe einrastet. Die Dichtscheibe muss bündig mit der Vorderseite der Spannmutter sein.

Demontage:

Um die Dichtscheibe zu entfernen, gleichmäßig von außen auf Dichtscheibe drücken bis sie herauspringt.

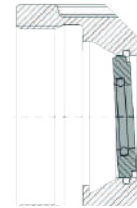
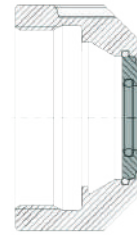
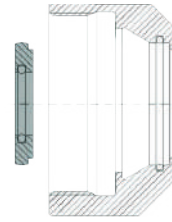



Der Gewindebohrprozess ist eine Kombination aus radialen und axialen Bewegungen. Es ist manchmal notwendig die axiale Bewegung des Werkzeugs einzuschränken.

Wenn die axiale Bewegung unkontrolliert verläuft, könnten die Führungszähne des Gewindebohrers nachschneiden und so ein übergroßes Gewinde erzeugen.

Längenausgleich (Zug) – der Ausgleich ermöglicht es dem Gewindebohrer ohne Einfluss von axialem Vorschub der Maschinenspindel ein Gewinde zu erzeugen.



Längenausgleich (Druck) – der Ausgleich wirkt wie ein Polster und erlaubt es dem Gewindebohrer in das Material einzudringen. Auch dieser Vorgang ist unabhängig vom Maschinenvorschub.

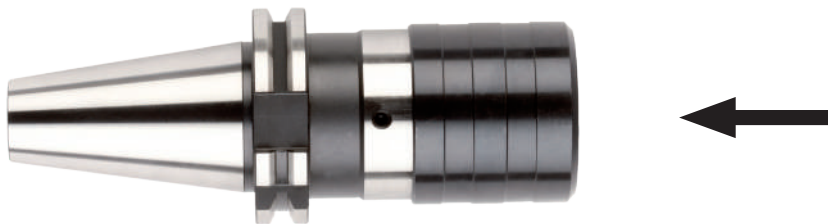

Längenausgleich (Druck/Zug) – der Ausgleich ist dazu gedacht alle externen Kräfte während des Bearbeitungsvorgangs auszugleichen.

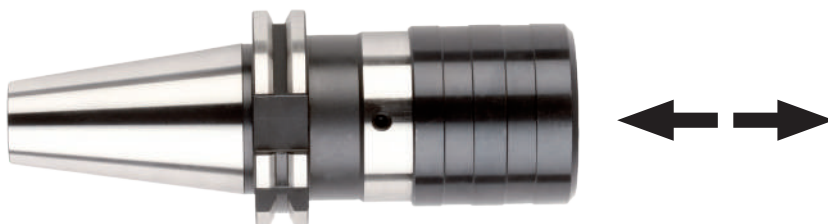

Radialer Pendelausgleich – gleicht eine geringe Abweichung der Maschinenspindel-Achse und der Bohrungsachse aus. Dieses sollte möglichst vermieden werden.





Bitte beachten Sie den angegebenen Längenausgleich in mm schon vor dem ersten Gewindeschneiden. Dies vermeidet ein Überschreiten der Werte und somit Futter- und Gewindebohrer-Beschädigungen.



Artikel	Bereich	Einsatz	Längenausgleich in mm auf	
			Druck	Zug
xxx.16.12	M 3- M14	16.11.xx / 16.01.xx	7	7
xxx.16.20	M 5 - M22	16.12.xx / 16.02.xx	12	12
xxx.16.36	M14 - M36	16.14.xx / 16.03.xx	17,5	17,5



Schaftmaße					
Ø × □	DIN 352	DIN 5157	DIN 371	DIN 374	DIN 376
Ø 2,5 × 2,1 □	M1		M1	M3	M3,5
Ø 2,5 × 2,1 □	M1,1		M1,1	M3,5	
Ø 2,5 × 2,1 □	M1,2		M1,2		
Ø 2,5 × 2,1 □	M1,4		M1,4		
Ø 2,5 × 2,1 □	M1,6		M1,6		
Ø 2,5 × 2,1 □	M1,8		M1,8		
Ø 2,8 × 2,1 □	M2		M2	M4	M4
Ø 2,8 × 2,1 □	M2,2		M2,2		
Ø 2,8 × 2,1 □	M2,5		M2,5		
Ø 3,5 × 2,7 □	M3		M3	M5	M5
Ø 4 × 3 □	M3,5		M3,5		
Ø 4,5 × 3,4 □	M4		M4	M6	M6
Ø 6 × 4,9 □	M5		M5		
Ø 6 × 4,9 □	M6		M6		
Ø 6 × 4,9 □	M8			M8	M8
Ø 7 × 5,5 □	M10	G 1/8"		M10	M10
Ø 8 × 6,2 □			M8		
Ø 9 × 7 □	M12			M12	M12
Ø 10 × 8 □			M10		
Ø 11 × 9 □	M14	G 1/4"		M14	M14
Ø 12 × 9 □	M16	G 3/8"		M16	M16
Ø 14 × 11 □	M18			M18	M18
Ø 16 × 12 □	M20	G 1/2"		M20	M20
Ø 18 × 14,5 □	M22	G 5/8"		M22	M22
Ø 18 × 14,5 □	M24			M24	M24
Ø 20 × 16 □	M27	G 3/4"		M27	M27
Ø 22 × 18 □	M30	G 7/8"		M30	M30
Ø 25 × 20 □	M33	G 1		M33	M33
Ø 28 × 22 □	M36	G 1 1/8"		M36	M36
Ø 32 × 34 □	M39	G 1 1/4"		M39	M39
Ø 32 × 24 □	M42			M42	M42
Ø 36 × 29 □	M45	G 1 3/8"		M45	M45
Ø 36 × 29 □	M48	G 1 1/2"		M48	M48
Ø 36 × 29 □		G 1 3/4"			
Ø 36 × 29 □		G 2"			

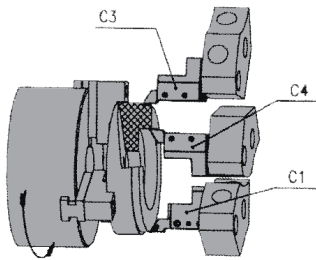

Einsatz von Radial-Werkzeughaltern bei linker Spindeldrehrichtung

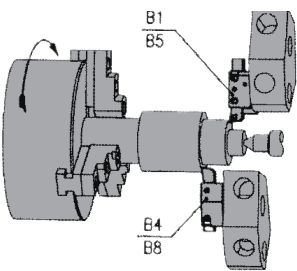

Einsatz von Radial-Werkzeughaltern bei rechter Spindeldrehrichtung

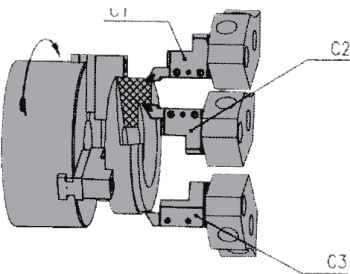

Einsatz von Axial-Werkzeughaltern bei linker Spindeldrehrichtung

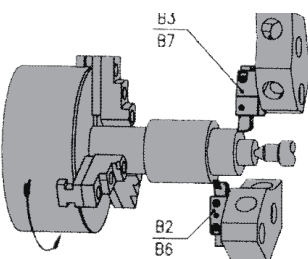

Einsatz von Axial-Werkzeughaltern bei rechter Spindeldrehrichtung



Das Kemmler Präzisions-Spannzangenfutter ist die Alternative zu Hydro-Dehnspannfuttern und Schrumpfaufnahmen.

Hohe Flexibilität durch austauschbare Spannzangen (Präzisions-Spannzangen System KPS verfügbar von Ø 0,5 bis 16 mm).

Hohe Spannkraft und Rundlaufgenauigkeit ergeben eine erstklassige Oberfläche und längere Werkzeugstandzeiten.

Glatte Spannmutter ohne Nuten für Hochgeschwindigkeitsbearbeitung.
Schlanke Ausführung.



Spannschaft:

Zylindrisch DIN 1835-1 Form A/DIN 6535 Form HA, Toleranz h_8 .

Werkzeugschäfte müssen dem nominalen Durchmesser der Spannzangen entsprechen. Spannzangen sind in Stufen von 0,5 mm verfügbar.

Rundlauf:

Max. Rundlauf-Abweichung 5 μm bei $4 \times d$ des eingespannten Werkzeugs.

Neigungswinkel:

Die Spannfläche hat einen Neigungswinkel von 4° , so dass radiale Kräfte während des Spanns nicht auftreten können und keinen Einfluss auf den Rundlauf haben.

Auswuchtung:

Standardmäßig feinausgewuchtet (G 2,5 30.000 min^{-1}).

Hinweis:

Spannzangenfutter System KPS werden standardmäßig ohne Anschlagsschrauben geliefert, da diese bei hohen Drehzahlen nicht zu empfehlen sind.

Spannzangen- größe	Spannbereich mm	Ø Stufen mm	Max. Anzugs- moment	Typ D Zulässige max. Drehzahl*
D16 (KPS 10)	0,5 – 10	0,5	40 Nm	60.000
D24 (KPS 16)	1,0 – 16	0,5	70 Nm	40.000

* Die max. Drehzahl für Aufnahmen dieser Art wird begrenzt durch Größe und Form des Kegelschaftes.



Übertragbares Drehmoment (Nm) auf Werkzeugschaft (statisch gemessen)

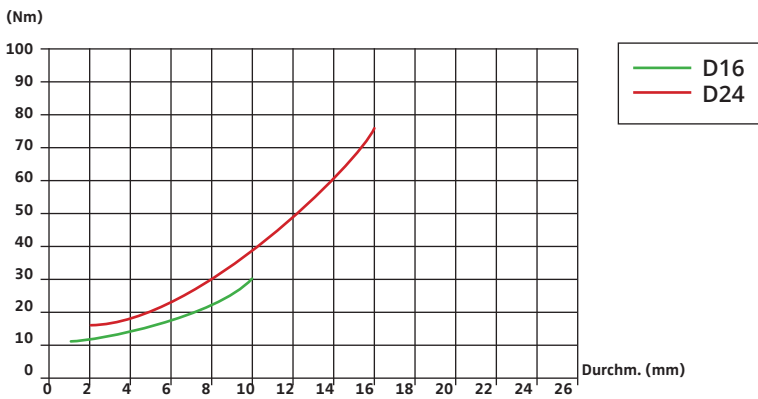

Montage der KPS-Spannzangen mit der Montagehilfe

1. Die Spannmutter vom Spannfutter lösen.
2. Die Spannzange in die Montagehilfe einsetzen.
3. Die Spannzange mit der Montagehilfe bis zum Anschlag in die Spannmutter einschieben.
4. Die Montagehilfe ausklinken.
5. Die Spannmutter mit der Spannzange auf das Spannfutter montieren.



Demontage

Setzen Sie die Spannzange zusammen mit der Spannmutter in die Montagehilfe ein, um die Spannzange zusammenzudrücken. Anschließend die Spannmutter entfernen.



KPS-Spannzange



KPS-Montagehilfe*



KPS-Spannmutter*



KPS-Spannschlüssel



Die Hochleistungs Kemmler Präzisions-Spannzangenfutter sind für nahezu alle Anwendungen geeignet. Insbesondere in der Schwerzerspannung garantieren wir unübertroffen hohen Spannkkräfte und hohe Prozesssicherheit. HKS Kraftspannfutter führen durch die Steifigkeit des Futter, seine Rundlaufgenauigkeit und das Spannen bereits bei 3mm ab Futter Nase zu hervorragendem Oberflächenfinish und günstigen Werkzeugstandzeiten. Alle HKS Kraftspannfutter gewähren eine maximale Abweichung der Rundlaufgenauigkeit von 3 µm bei 3 x D.

Verwendung:

- Schwerzerspannung
- Schlichtfräsen
- Hartfräsen
- Bohren, Reiben
- Gewindefräsen

Rundlauf:

Max. Rundlauf-Abweichung 3 µm bei 3×d des eingespannten Werkzeugs.

Auswuchtung:

Standardmäßig feinausgewuchtet (G 6,3 15.000 min⁻¹).

Spannschaft:

Alle marktüblichen Werkzeugschäfte mit oder ohne Weldonschaft können direkt oder mit Spannhülse gespannt werden.

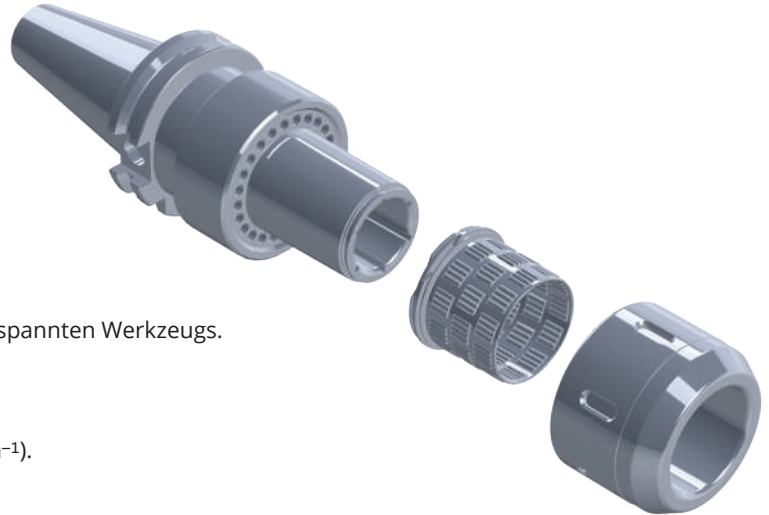

Größe	20mm	25mm	32mm
Anzugsmoment	50-70 Nm	80-100 Nm	80-100 Nm
Spannkraft	780 Nm	2000 Nm	2000 Nm



RELEASE THE BEAST





Präzisions-Spannzangenfutter ER

für Spannzangen ISO 15488 (DIN 6499) System ER



Verstärkter Futterkörper:
Für bessere Stabilität und höhere radiale Steifigkeit

Glatte Spannmutter ohne Nuten für Hochgeschwindigkeitsbearbeitung



Präzision ER

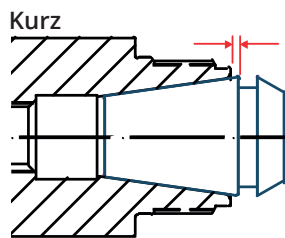

Standard ER

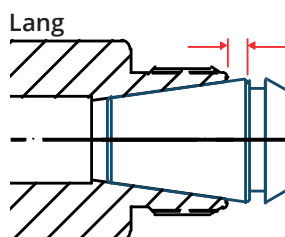

KEMMLER Präzisions-Spannzangenfutter:
Der tiefere Sitz der Spannzange im Spannfutter führt zu präziserem Rundlauf und einem deutlichen Plus an radialer Stabilität. Extreme Haltekräfte (erhöht die Haltekraft um mindestens 60 % im Vergleich zu Standard ER-Spannzangenfuttern)

Laserbeschriftung der Werkzeuge



Laserbeschriftung von Werkzeugaufnahmen

Durch unsere Laserbeschriftungsanlagen können wir Ihnen individuelle, kostengünstige Laserbeschriftung der Werkzeuge anbieten. Die dauerhafte Beschriftung kann mit Ihrem Firmennamen, Firmenlogo oder mit sonstigen Sonderzeichen erfolgen. Ebenfalls können die Etiketten auf den Verpackungen nach Ihren Vorgaben gestaltet werden.



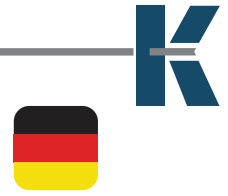

Werkzeugparameter nach ISO 13399

Dieser Katalog wurde gemäß ISO 13399 „Werkzeugdatendarstellung und -austausch“ erstellt, um eine einfache Handhabung der Werkzeug- und Produktdaten zu ermöglichen.

Hier finden Sie eine Aufzählung der in unserem Katalog verwendeten ISO-Attribute und Merkmalbenennungen. Eine vollständige Auflistung der Werkzeugparameter nach ISO/TS 13399 finden Sie auf unserer Internetseite.

ISO-Attribut	Merkmalbenennung
ADJRG	Verstellbereich, axial
BD	Körper-Durchmesser
BHTA	Kegeleinstellwinkel
BTED	Kegelenddurchmesser
CND	Kühlschmierstoffeintritt, Durchmesser
CNT	Gewindegröße Eingang Kühlmittel
CRKS	Anzugsbolzengewindegröße
CTWS	Schnittstellenbezeichnung werkstückseitig
CXD	Kühlschmierstoffaustritt, Durchmesser
CXT	Gewindegröße Ausgang Kühlmittel
DCF	Funktionsdurchmesser
DCONMS	Aufnahme-Ø, masch.seitig
DCONWS	Spann-Ø, nominal, werkst.seitig
DF	Bund-Ø
DLN	Außendurchmesser Spannmutter
DMIN	Bohrungs-Ø, min.
DRVS	Schlüsselweite
FLGT	Flanschdicke
HF	Funktionshöhe
HLN	Höhe Spannmutter
HTB	Körperhöhe
LB	Grundkörperlänge
LBD	Länge Körper-Durchmesser
LCOL	Spannzangen, Spannhülsenlänge
LCOMP	Längenausgleichskomprimierung
LDRED	Länge, reduzierter Körperdurchmesser
LF	Funktionslänge
LFSF	Abstand Stirnfläche
LH	Kopflänge
LPR	Kraglänge
LS	Schaftlänge
LSC	Spannlänge
LSCN	Einspannlänge, min.
LSCX	Einspannlänge, max.
OAH	Gesamthöhe
OAL	Gesamtlänge
OAW	Gesamtbreite
PHD	Ausgangsdurchmesser
RADH	Radialhöhe
RADW	Radialbreite
RADWOF	Radialfreisparungsbreite
SZID	Nenngröße
TD	Gewindenenddurchmesser, metrisch
TDCON	Toleranzklasse Anschlussdurchmesser
THID	Gewindebezeichnung, innen
THL	Gewindeschneidteillänge
THOD	Gewindebezeichnung, außen
THSZMS	Aufnahmegewindenenngröße, masch.seitig
THSZWS	Aufnahmegewindenenngröße, werks.seitig
TP	Gewindesteigung
TQX	Drehmoment, max.
WF	Funktionsbreite



Steep taper	13.33	
Pull studs	13.34	
HSK (hollow taper shanks)	13.35	
Overview HSK (hollow taper shanks)	13.37	
HSK coolant tubes	13.38	
Effects of imbalance on machine spindles, toolholders and tools	13.39	
Hydraulic expansion chucks	13.41	
Operating and user instructions for hydraulic expansion chucks	13.42	
Torques for clamping end-mills	13.43	
Operating and user instructions for CNC-drill chucks	13.44	
Mounting instructions for ER-collets per ISO 15488 (DIN 6499)	13.45	
Mounting instructions for sealing discs	13.46	
Quick-change tapping chucks	13.47	
Instructions for tapping chucks	13.48	
Screw taps-shaft size	13.49	
Tool assignment for disc turrets	13.50	
High precision collet chucks KPS-system	13.51	
High-performance milling chucks HKS-system	13.53	
Precision collet chuck ER for collets ISO 15488 (DIN 6499) ER-system	13.55	
Laser engraving of toolholders - KEMMLER OEM -	13.56	
The Kemmler-numerical code	13.57	
ISO designation system	13.58	



Large manual machines and CNC machines use toolholders that have been precisely ground with a male taper that mates with the machine's specific female taper. There is also a way to secure the toolholder in place with a pull stud or a draw bar thread. With CNC machines, the pull stud is more popular because it allows for easier automatic tool changing.

A toolholder consists of five basic components:

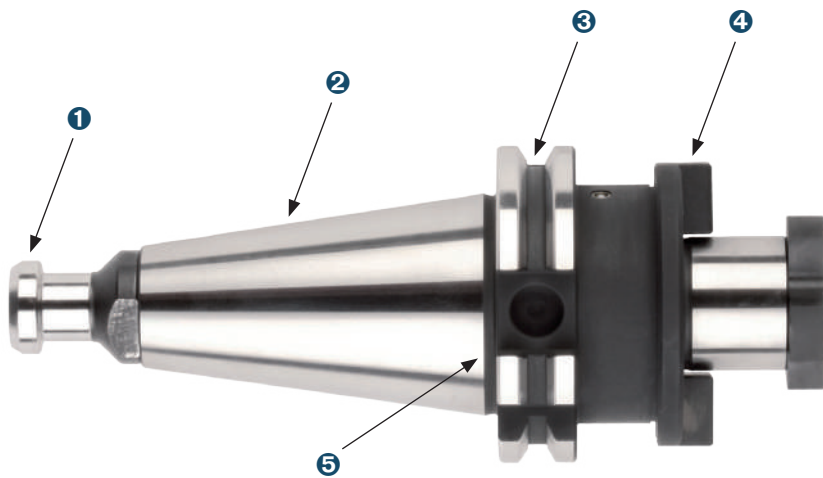

- 1 Pull Stud
- 2 Tapered Shank
- 3 Gripper groove: circular groove
- 4 Adapter
- 5 Opposed Slot

Tapered shank

The standard defines six basic taper shank sizes including SK 30, SK 35, SK 40, SK 45, SK 50, and SK 60.

The proper Taper Shank for the Type of Machine

- ISO 60 Very large machines
- ISO 50 Medium size machines
- ISO 40 Small size machines
- ISO 30 Very small machines

Coolant supply form AD/B

Toolholders form AD/B have internal coolant supply. To use form B (coolant supply through the collar) the two headless screws must be removed and a sealed pull stud must be inserted. To use form AD (central coolant supply) the two headless screws must remain at the collar and a pull stud with drill through must be inserted.

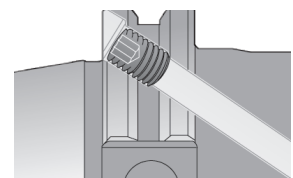



Pull studs are an important link between machine and tool.
The tightening bolt allows the clamping gripper of the spindle to pull the tool holder firmly into the spindle and eject it automatically.

Pull studs / Retention knobs come in different designs and sizes. They are not interchangeable. In addition to the pull studs according to DIN ISO 7388-3 (formerly DIN 69872), there are a variety of factory standards specified by the respective machine tool manufacturer.

Application:

- For tools with steep taper shank ISO 7388-1 and ISO 7388-2 [formerly DIN 69871 and JIS B 6339 (MAS-BT)]
- In machining centres (machines with automatic tool changer)
- In NC machines (machines without automatic tool changer)
- For tools with axial coolant supply
- For tools with or without axial coolant supply

Only use the pull studs that are specified by the machine tool manufacturer.

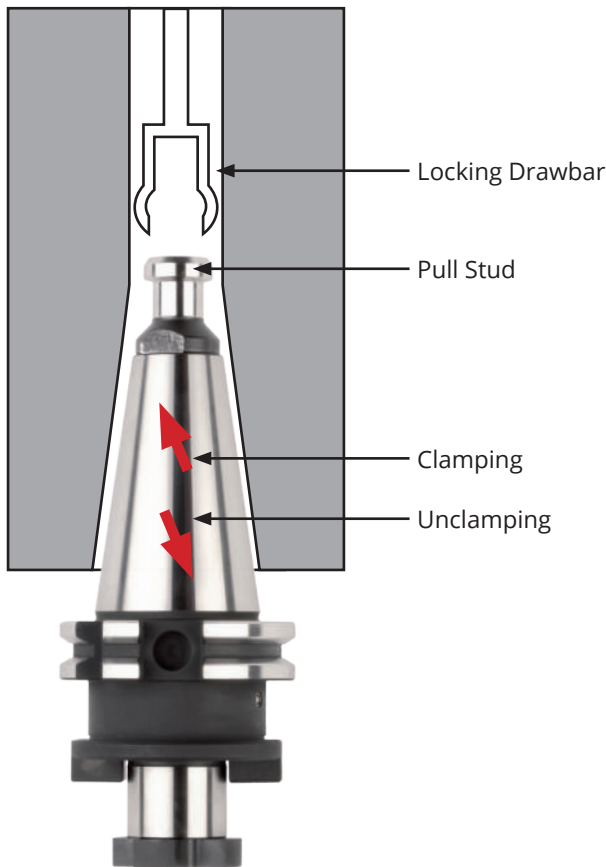

Recommended torque for pull stud tightening:

SK / BT / ISO 30	20 Nm
SK / BT / ISO 40	50 Nm
SK / BT / ISO 50	100 Nm



Normative references:

DIN ISO 7388 consists of the following parts, under the general title Tool shanks with 7/24 taper for automatic tool changers:

- Part 1: Dimensions and designation of shanks of forms A, AD, AF, U, UD and UF
- Part 2: Dimensions and designation of shanks of forms J, JD, and JF
- Part 3: Retention knobs for shanks of forms AC, AD, AF, UC, UD, UF, JD, and JF

DIN ISO 7388-3

Tool shanks with 7/24 taper for automatic tool changers – Part 3: Retention knobs for shanks of forms AC, AD, AF, UC, UD, UF, JD and JF (ISO 7388-3:2013), English translation of DIN ISO 7388-3:2015-03

DIN ISO 7388-3 is a replacement for DIN 69872:1988-07



HSK-toolholders DIN 69893

The hollow taper shank (HSK) has prevailed since its standardization as an interface between machine and tool.

HSK benefits to the user include:

- High static and dynamic rigidity
- High precision axial and radial reproducibility
- High tool change accuracy and repeatability
- High speed machining performance
- Short tool changing times
- Coding and identification
- Coolant feed

Balancing recommendations and r.p.m. limits

Kemmler HSK-toolholders are generally pre-balanced to G 6.3/15,000 rev./min.

Fine balancing on request is possible.

Because the rotational speed is the largest influencing factor together with the limits regarding the spindle or spindle bearing interface, the following r.p.m. limits for HSK interfaces have been recommended as guidelines within the HSK standards:

HSK-A/C 32 to 30,000 rev./min

HSK-A/C 40 to 30,000 rev./min

HSK-A/C 50 to 30,000 rev./min

HSK-A/C 63 to 25,000 rev./min

HSK-A/C 80 to 20,000 rev./min

HSK-A/C 100 to 16,000 rev./min

Depending on the tool, it may be necessary to balance both the tool holder and tool when applying the maximum r.p.m. Exact limits can only be determined if machine and spindle manufacturers are taken into consideration and it is possible to define tools and projecting lengths.

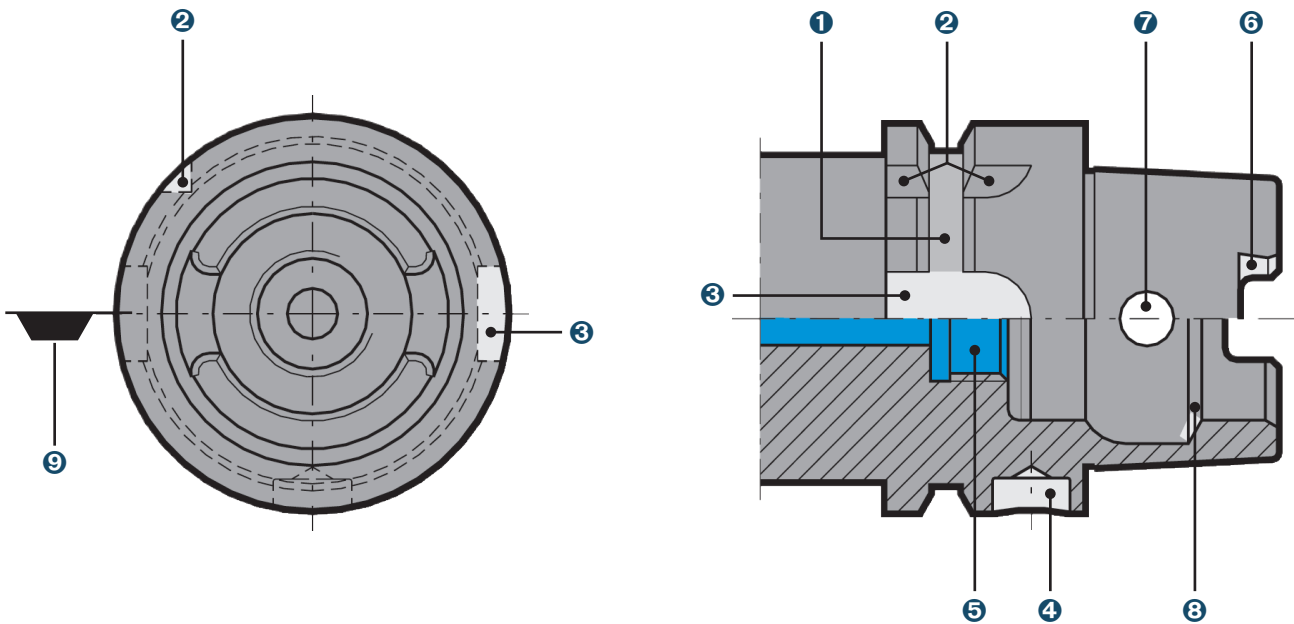

Term definitions of HSK-A interface for automatic tooling systems

- ❶ Gripper groove: circular groove
- ❷ Index notch: sickle-shaped notch across gripper groove
- ❸ Keyway on collar:
index notch or for attachment in tool magazine or grippers.
With HSK-B/D also provides form closed torque transmission to spindle.
- ❹ Coding/identification:
bore in collar for attachment of identification system (coding chip)
- ❺ Thread for coolant: for attachment of coolant supply set
- ❻ Keyway on taper shank: form closed torque transmission to spindle
- ❼ Radial bore in taper shank: necessary for manual clamping systems
- ❽ Clamping shoulder: circular chamfer for drawing in the tool
- ❾ Position of the tool edge of single-edged tools



DIN 69063-1 (ISO 12164-1) Form A

Standard type for machining centres and milling machines. HSK for automatic tool change with gripper groove and index notch. Manual operation is via access hole in taper. Form B relies on driving dogs on the joint face as shank isn't slotted. Torque is transmitted through highly accurate connection.

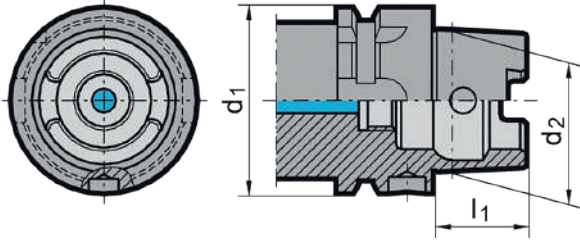

DIN 69063-2 (ISO 12164-1) Form B

For machining centres, milling and turning machines. With enlarged flange size for rigid machining. For automatic tool change. Coolant supply through the flange. Drive keys at the flange. Hole for data carrier DIN STD 69873 at the flange.

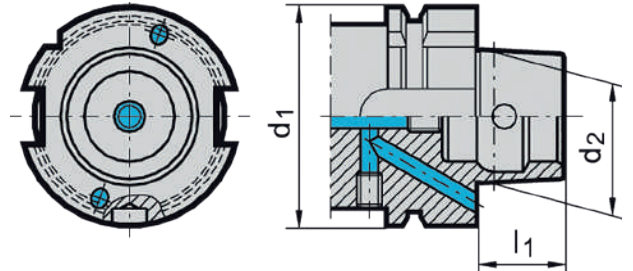

DIN 69063-1 (ISO 12164-1) Form C

For transfer lines, special machines and modular tooling systems. HSK for manual tool change. Operation is via access hole in taper. Form D relies on driving dogs on the joint face as shank isn't slotted. Torque is transmitted through highly accurate connection.

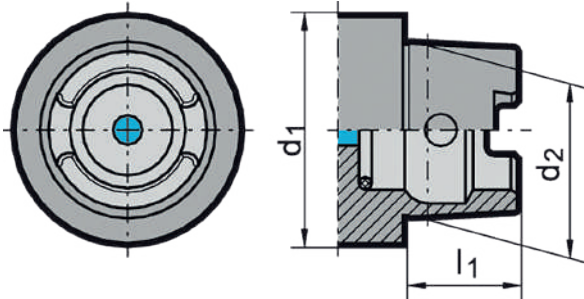

DIN 69063-2 (ISO 12164-2) Form D

For special machines. With enlarged flange size for rigid machining. For manual tool change. Coolant supply through the flange. Drive keys at the flange.

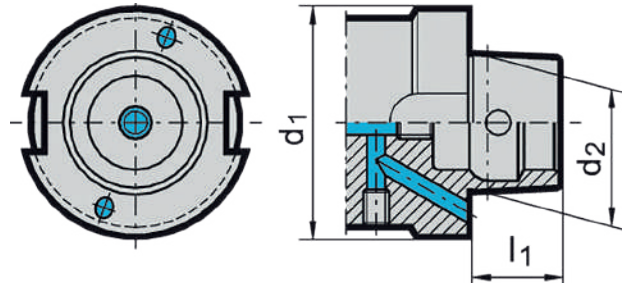

DIN 69063-5 Form E

For high-speed applications. For automatic tool change. HSK for automatic tool change. Torque is transmitted through highly accurate connection. Version with access hole acc. to DIN 69893-1 by arrangement.

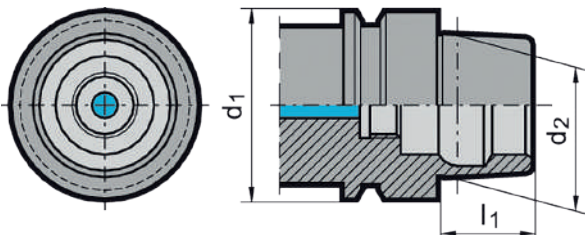

DIN 69063-6 Form F

For high-speed applications mainly in woodworking industries. HSK for automatic tool change. Torque is transmitted through highly accurate connection. Version with access hole acc. to DIN 69893-1 by arrangement.

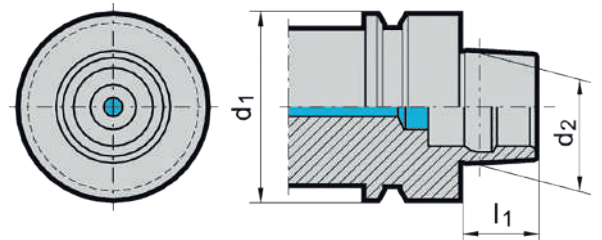



HSK form A, -B or -D holders must be equipped with a coolant tube.

Using holders without a coolant tube could cause unseen machine spindle damage.

DIN 69893 Form C, -E and -F do not require a coolant tube. Through coolant and sealing functions are provided by the locking unit.

The coolant tube is ideally mounted in vertical direction – from the bottom to the top. In this manner the sealing ring is prevented from being compressed during location which would cause the loss of its sealing function.

After mounting, the coolant pipe can be moved only to a minimum degree according to DIN ($\pm 1^\circ$).

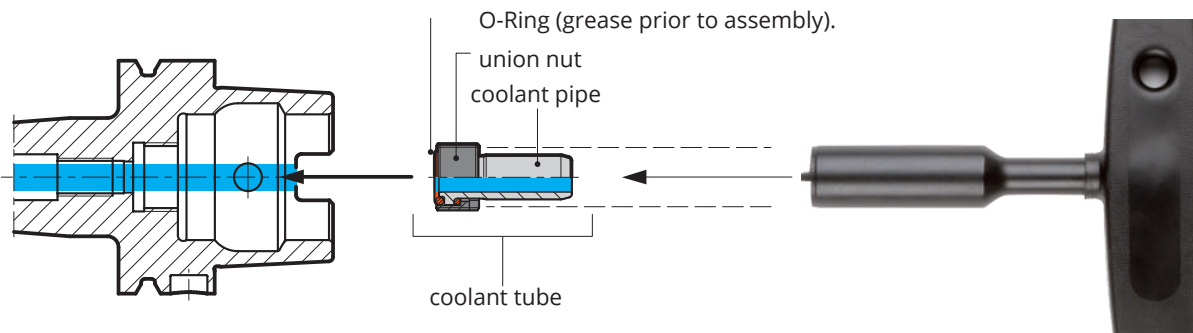

Installation

1. The HSK holder must be clean, free of swarf and undamaged.
2. Grease the O-rings prior to assembly.
3. Centrally insert the complete coolant tube (coolant pipe, union nut and 2 O-rings) in the HSK with the assistance of the socket spanner.
4. Screw in the coolant tube and tighten (see table for torque figures)
5. Check coolant pipe for radial mobility.

Torque figures

for HSK	Mt (Nm)
32	7
40	11
50	15
63	20
80	25
100	30



Imbalance

An imbalance produces a centrifugal force during the rotation of the spindle impeding the smooth running of the tool. This imbalance influences the working process and the life span of the spindle bearings. The centrifugal force F increases linear with the imbalance U and squared with the number of revolutions according to the formula below.

Counter balancing

To compensate for unwanted centrifugal forces, the symmetrical distribution of mass must be restored with the aim of eliminating any centrifugal forces influencing the spindle bearing. Tool holders generally have compensation holes or areas which assist in directing the total amount of all centrifugal forces influencing the axis towards zero (see DIN ISO 1940).

Eccentricity of center of gravity

The imbalance of a spindle causes its center of gravity to deviate a certain distance from the rotating axis in direction of the imbalance. This distance is called rest-eccentricity e or eccentricity of center of gravity. The heavier the weight of the balance body mass m , the greater the restimbalance U permissible.

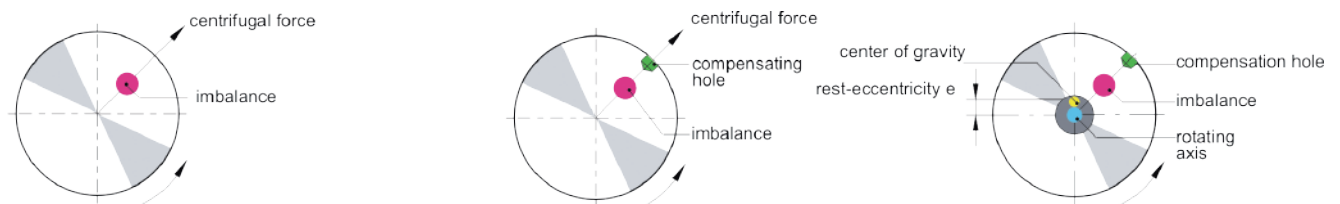

Calculation imbalance

Imbalance is a measure, specifying how much unsymmetrical distributed mass deviates radially from the rotating axis. Imbalance is measured in gmm. The measure of distance e determines the distance of the center of gravity of an element to the rotating axis.

Imbalance is calculated as follows:

$$U = m \times r$$

U = imbalance in gmm

e = eccentricity of center of gravity in μm

m = mass in kg



Balancing limits

In accordance with DIN ISO 1940 the balance grade is denoted with G as well as the units gmm/kg or μm respectively and is relative to the number of revolutions. At a speed of 15,000 rev./min and a weight of 1 kg, G 6.3 corresponds with a permissible center deviation between rotational axis and center of gravity axis of the spindle of 4 μm . At twice the speed of 30,000 rev./min it would be 2 μm . If the tool holder was only half the weight, i.e. 0.5 kg, the permissible counter balancing tolerance is also halved. Aim of counter balancing is to find a compromise between the technically feasible and the economically efficient. Because the radial interchange accuracy for a brand-new HSK holder can be 2 to 3 μm and for an ISO taper shank holder can be 5 to 10 μm , it means an initial quality limit of G 2.5 or G 6.3 respectively at 10,000 rev./min.

The following diagram shows the quality grades to DIN ISO 1940-1, i.e. the permissible rest imbalance in relation to the balance body mass for different counter balance qualities G relative to the maximum operating speed.

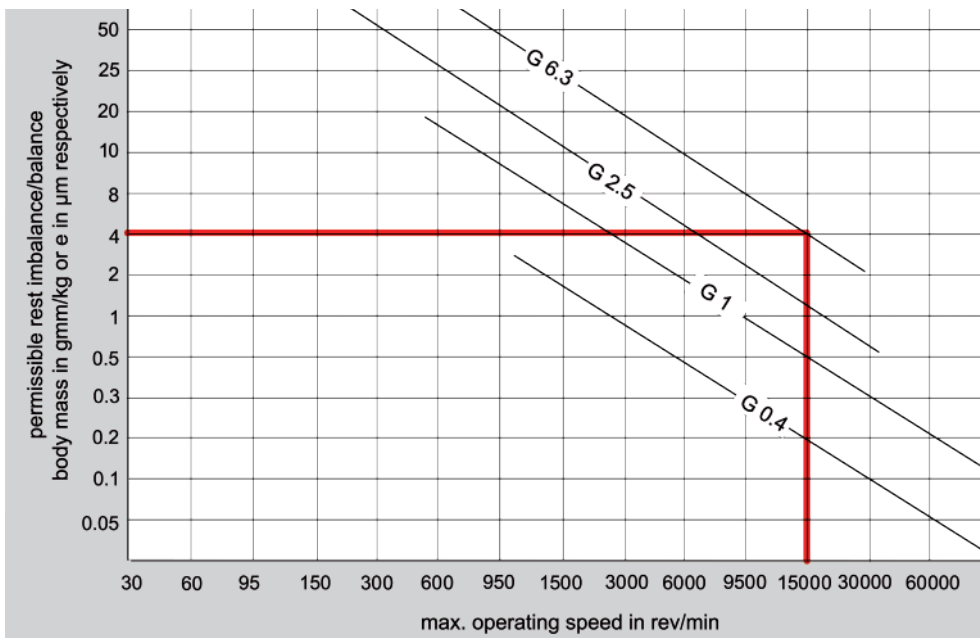

KEMMLER tool holders are balanced to G 6.3/15,000 rev/min.

Fine-balanced with balancing bores in the flange

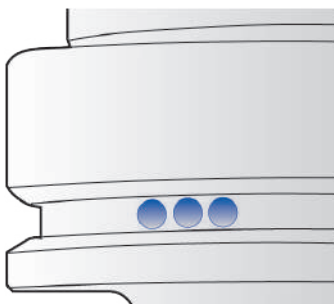

Pre-balanced with balancing bores at the collar

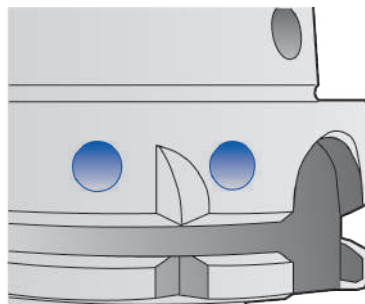

Pre-balanced with balancing flat at the tool body

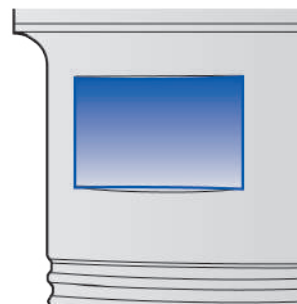



Modern machining processes place heavy demands on tool holding. Hydraulic expansion chucks provide excellent clamping characteristics combined with precise concentricity. Furthermore, they enable a simple and fast tool change.

Turning the pressure screw generates sufficient pressure in the pressure chamber resulting in an elastic deformation of the clamping bush, providing powerful tool clamping and precise concentricity. A safe and powerful fit is guaranteed. If reduction sleeves are applied that are able to hold varying tool diameters, the tool application may be extended without problem. If such sleeves are not applied, it is essential to observe the minimum clamping length!



Advantages

- precise tool clamping with a maximum 3 µm deviation from concentricity
- transmission of high torque through (excellent clamping) optimised bush clamping system
- high speed compatibility (no centrifugal forces from clamping segments)
- precise concentricity, therefore excellent surface qualities and dimensional accuracy of the workpiece
- rapid tool change thanks to simple operation of the clamping screw
- optimal tool life
- hydraulic cushioning has vibration absorbing effect

Chart of technical data

Clamping Ø [mm]	Tightening torque [Nm]	Minimum clamping depth of the tool [mm]	Admissible transmissible torque [Nm]	Shank tolerance	max. RPM [min ⁻¹]	
					LPR ≤ 125 mm	LPR > 125 mm
6	10	27	12	h6	40.000	20.000
8	10	27	30	h6	40.000	20.000
10	10	31	40	h6	40.000	20.000
12	10	36	70	h6	40.000	20.000
14	10	36	100	h6	40.000	20.000
16	10	39	135	h6	40.000	20.000
18	10	39	180	h6	40.000	20.000
20	10	41	220	h6	40.000	20.000
25	10	47	500	h6	20.000	10.000
32	10	51	700	h6	20.000	10.000

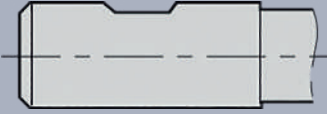
Usable shank types

DIN 6535 DIN 1835-1	Ø 6 - 20 mm	Ø 25 - 32 mm	Using Reduction sleeves
 Form HA	✓	✓	✓
 Form HB/ E	✓	✗	✓
 Form HE/ E	✗	✗	✓
Run out (↗)	≤ 0,003 mm		≤ 0,005 mm



To ensure a flawless function of the hydraulic expansion chucks, please observe the following instructions:

Usage of straight shank tools according to DIN 1835 and DIN 6535 form (HA) and B (HB) up to \varnothing 20 mm shaft diameter with tolerance h_6 , precision grinded $Ra_{min} = 0.3$.

Shafts according to DIN 6535 form HE (Whistle Notch) can only be clamped by using reduction sleeves. All hydraulic expansion chucks are standard balanced to G 6.3 15,000 rev/min.

Clamping and unclamping the tool

1. Clean the holding fixture bore and the tool shaft of grease and dirt. Insert tools up to the end stop. Observe the minimum clamping depth and the length adjustment range.
2. Clamp the shaft by turning the clamping screw up to the end stop. The tool is clamped. To avoid breaking of the hydraulic sleeve, do not carry out clamping action without a tool.
3. To unclamp the tool, turn the screw approx. 5 to 6 revs. counter clockwise and remove the tool.



Note: Never clamp without a clamped tooling!

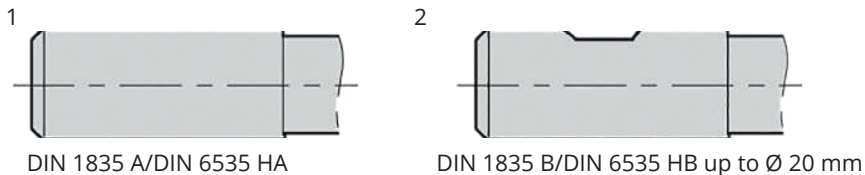

Cleaning

Attention should be paid to the cleanliness of the holding fixture bore and the tool shaft.

Temperature

Optimal temperature range between 10 – 50°. Do not use with temperatures above 80°.

Storage

Store the hydraulic expansion chuck untensioned, cleaned and lightly oiled.

Clamping shafts

Clamp only tool shafts conforming to the requirements of DIN 1835 form A and form B (up to 20 mm).

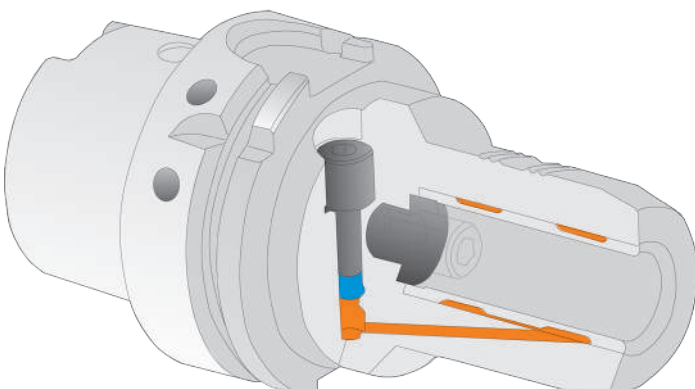



Highest concentricity by using defined torques with Weldon shafts:



Torques for DIN 1835

Bore	Screw		Torque
Ø 6 mm	M 6	SW 3	10 Nm
Ø 8 mm	M 8	SW 4	10 Nm
Ø 10 mm	M 10	SW 5	16 Nm
Ø 12 mm	M 12	SW 6	28 Nm
Ø 14 mm	M 12	SW 6	28 Nm
Ø 16 mm	M 14	SW 6	42 Nm
Ø 18 mm	M 14	SW 6	42 Nm
Ø 20 mm	M 16	SW 8	50 Nm
Ø 25 mm	M 18 × 2	SW 10	60 Nm
Ø 32 mm	M 20 × 2	SW 10	72 Nm
Ø 40 mm	M 20 × 2	SW 10	72 Nm
Ø 50 mm	M 24 × 2	SW 12	90 Nm
Ø 63 mm	M 24 × 2	SW 12	90 Nm

The load limits of the spindle mount must be complied with.

Operating temperature: + 20 °C ... + 50 °C

Max. coolant pressure: 80 bar

Clamp-Ø	max. Speed in m ⁻¹		Max. Tightening torque of the clamping screw	Clamping screw	SW	Shank-Ø in mm
	LPR to 125mm	LPR about 125mm				
Ø 6 mm	50.000	30.000	10 Nm	M 6	SW 3	Ø 6 h6
Ø 8 mm	50.000	30.000	10 Nm	M 8	SW 4	Ø 8 h6
Ø 10 mm	50.000	30.000	16 Nm	M 10	SW 5	Ø 10 h6
Ø 12 mm	50.000	30.000	28 Nm	M 12	SW 6	Ø 12 h6
Ø 14 mm	50.000	30.000	28 Nm	M 12	SW 6	Ø 14 h6
Ø 16 mm	50.000	30.000	42 Nm	M 14	SW 6	Ø 16 h6
Ø 18 mm	50.000	30.000	42 Nm	M 14	SW 6	Ø 18 h6
Ø 20 mm	50.000	30.000	50 Nm	M 16	SW 8	Ø 20 h6
Ø 25 mm	25.000	20.000	60 Nm	M 18 × 2	SW 10	Ø 25 h6
Ø 32 mm	25.000	20.000	72 Nm	M 20 × 2	SW 10	Ø 32 h6



Use clamping and unclamping of tools

To guarantee error-free function of the CNC-drill chuck 08/ 13/ 16, please follow the next instructions.

Attention:

Clamping or releasing only at standstill of machine spindle or outside the machine.

The CNC-drill chuck (pos. 1) is clamped by means of an Allen-T-wrench (pos. 3) on side of the drill chuck actuating a bevel gear. Turn the Allen-T-wrench counter clockwise to open the drill chuck, clockwise to close it.

1st step

Open the jaw of the drill chuck wide enough to insert the cutting tool. (pos. 2)

2nd step

Fit cutting tool (pos. 2) to the stud into the CNC-drill chuck (pos. 1) so that the tool shank is fit closely to the whole length of the clamping jaws. (picture 1)

3rd step

Turn the Allen-T-wrench (pos. 3) clockwise to clamp the cutting tool using a torque of 15 Nm (10 Nm for 0,5-8) to clamp the tool properly. (picture 2)

Note:

Do not use any kind of extensions for clamping. By using a torque higher than mentioned the bevel gear can be damaged. In this case the bevel pinion will be the rated break point to protect the drill chuck against damage.

4th step

Test the concentricity after clamping and make sure that the tool is clamped safely.

Note:

Do not clamp tools with tapered shafts.

5th step

The CNC-drill chuck is ready for work and can be clamped into the machine spindle. (picture 3)

6th step

To release the cutting tool please turn the Allen-T-wrench counter clockwise and remove the cutting tool. (picture 3)

Maintenance and Cleaning

The CNC-drill chucks 08 / 13 / 16 are maintenance-free.
The CNC-drill chucks 08 / 13 / 16 should be cleaned after use with a clean cloth to prevent corrosions.
Before storing the drill chucks please spray oil on the surface to prevent corrosion.

Repair

In case of a damage of the CNC-drill chuck, please send it back to us. We will principally exchange the complete drill chuck head.

With this procedure you will get the quickest possible replacement and only on this way a proper function and a run-out accuracy of < 0.03 mm can be guaranteed.



picture 1



picture 2



picture 3



Assembling instructions:

Insert groove of collet into eccentric ring of the clamping nut at the mark on the bottom of the nut. Push collet in the direction of the arrow until it clicks in place. Screw nut with collet onto toolholder. We recommend to tighten the nut with a torque wrench.

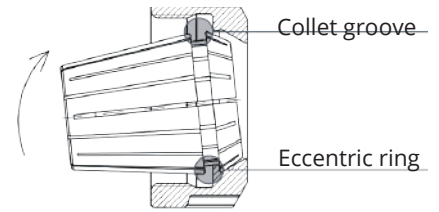

Disassembling instructions:

After the nut is unscrewed from the toolholder, press on the face of the collet while simultaneously pushing sideways on the back of the collet until it disengages from the clamping nut.

Improper assembly can permanently destroy the concentricity of the collet and may result in a damaged clamping nut.

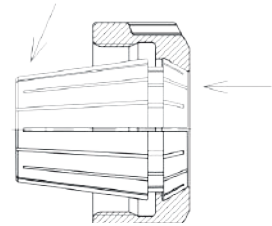

Note:

Only mount nuts with correctly inserted collets! Never place the collet into the holder without first assembling it into the nut.

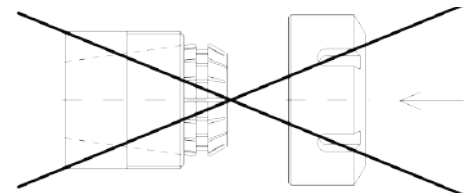

Never clamp oversize tool shanks!

e.g. never use a \varnothing 12–11 mm collet to clamp a \varnothing 12.2 mm shank. Rather use the next bigger collet (here \varnothing 13–12 mm collet).

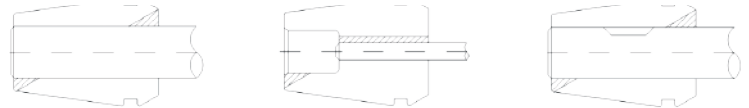

Insert tool the full length of the collet for best results if possible. However, never insert tool less than 2/3 of the collet bore length. Improper tool insertion can permanently deform the collet and will result in poor runout.



Maximum torque

ER 16	M22 × 1,5	50 Nm
ER 20	M25 × 1,5	75 Nm
ER 25	M32 × 1,5	85 Nm
ER 32	M40 × 1,5	105 Nm
ER 40	M50 × 1,5	150 Nm
<hr/>		
ER 11 Mini	M13 × 0,75	18 Nm
ER 16 Mini	M19 × 1	28 Nm

Please observe the maximum torque indicated in the chart!



Assembly

Insert the small diameter of the disc into the centre of the coolant nut and apply even pressure until the disc is properly seated into the nut. The disc must be flush with the outside of the nut.

Removal

To remove the disc, simply press on the outside of the disc evenly, until it snaps out.

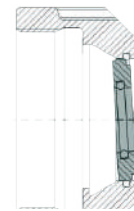
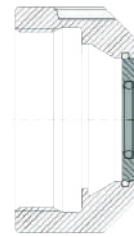
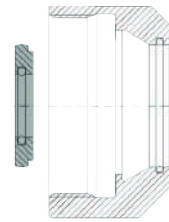



The process of tapping is a complex balance of rotational and axial movements of the tool. It is sometimes necessary to restrict the axial movements of the tool.

If the axial movement is not accurately controlled, the leading or trailing flanks of the tap may be forced to progressively “shave” one flank of the component thread, thus producing a thin and oversize thread in the component.

Tension – forward float capability allows the tap to progress into the component without interference from the axial feed of the machine spindle.

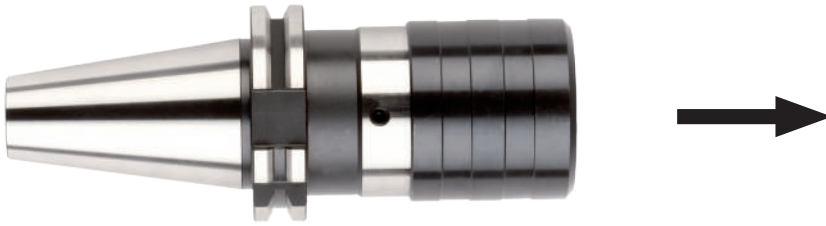

Compression – backward float capability, acts as a cushion and allows the tap to commence cutting at its own axial feed independent of the machine spindle.

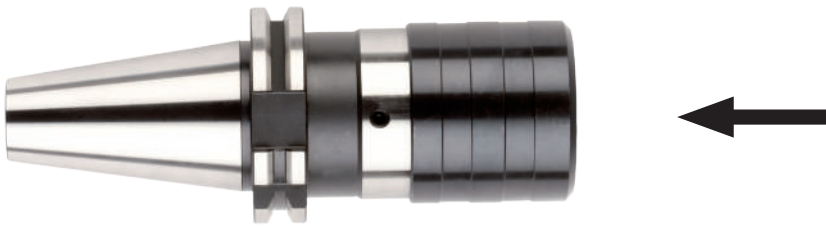

Compression/Tension – float is designed to negate any external forces during the machining operation.



Radial float – allows for slight misalignment of the machine spindle axis and hole axis prior to tapping. This is not recommended manufacturing practice and should be avoided.

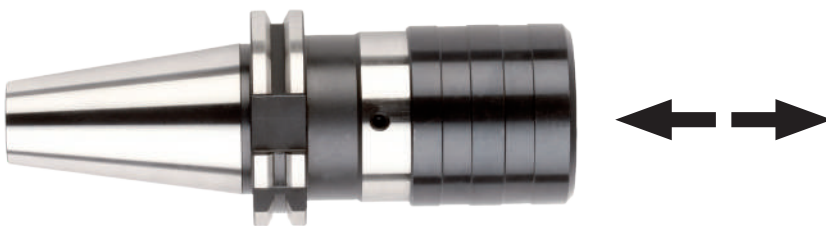



For a correct use of the tapping chuck, please check, during the first thread, not to exceed the max. axial stroke of the compensation values. This is to avoid damaging the thread or the tapping chuck.



Code	Tap capacity	Adapters	Length adjustment in mm on	
			Compression	Extension
xxx.16.12	M 3 - M14	16.11.xx / 16.01.xx	7	7
xxx.16.20	M 5 - M22	16.12.xx / 16.02.xx	12	12
xxx.16.36	M14 - M36	16.14.xx / 16.03.xx	17.5	17.5



Shaft diameter					
Ø × □	DIN 352	DIN 5157	DIN 371	DIN 374	DIN 376
Ø 2.5 × 2.1 □	M1		M1	M3	M3.5
Ø 2.5 × 2.1 □	M1.1		M1.1	M3.5	
Ø 2.5 × 2.1 □	M1.2		M1.2		
Ø 2.5 × 2.1 □	M1.4		M1.4		
Ø 2.5 × 2.1 □	M1.6		M1.6		
Ø 2.5 × 2.1 □	M1.8		M1.8		
Ø 2.8 × 2.1 □	M2		M2	M4	M4
Ø 2.8 × 2.1 □	M2.2		M2.2		
Ø 2.8 × 2.1 □	M2.5		M2.5		
Ø 3.5 × 2.7 □	M3		M3	M5	M5
Ø 4 × 3 □	M3.5		M3.5		
Ø 4.5 × 3.4 □	M4		M4	M6	M6
Ø 6 × 4.9 □	M5		M5		
Ø 6 × 4.9 □	M6		M6		
Ø 6 × 4.9 □	M8			M8	M8
Ø 7 × 5.5 □	M10	G 1/8"		M10	M10
Ø 8 × 6.2 □			M8		
Ø 9 × 7 □	M12			M12	M12
Ø 10 × 8 □			M10		
Ø 11 × 9 □	M14	G 1/4"		M14	M14
Ø 12 × 9 □	M16	G 3/8"		M16	M16
Ø 14 × 11 □	M18			M18	M18
Ø 16 × 12 □	M20	G 1/2"		M20	M20
Ø 18 × 14.5 □	M22	G 5/8"		M22	M22
Ø 18 × 14.5 □	M24			M24	M24
Ø 20 × 16 □	M27	G 3/4"		M27	M27
Ø 22 × 18 □	M30	G 7/8"		M30	M30
Ø 25 × 20 □	M33	G 1		M33	M33
Ø 28 × 22 □	M36	G 1 1/8"		M36	M36
Ø 32 × 34 □	M39	G 1 1/4"		M39	M39
Ø 32 × 24 □	M42			M42	M42
Ø 36 × 29 □	M45	G 1 3/8"		M45	M45
Ø 36 × 29 □	M48	G 1 1/2"		M48	M48
Ø 36 × 29 □		G 1 3/4"			
Ø 36 × 29 □		G 2"			

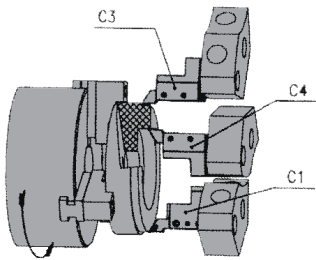

Application of radial tool holders with counter clockwise spindle rotation

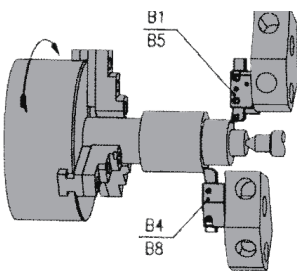

Application of radial tool holders with clockwise spindle rotation

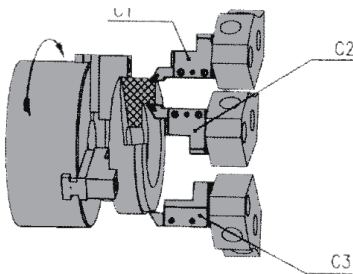

Application of axial tool holders with counter clockwise spindle rotation

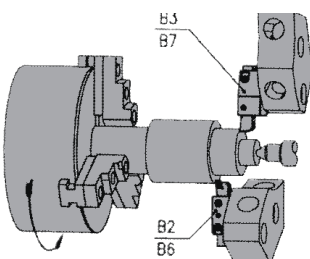

Application of axial tool holders with clockwise spindle rotation

K High precision collet chucks KPS-system



The high precision collet chuck (KPS) is the alternative to hydraulic expansion chucks and shrink chucks.

High flexibility due to interchangeable collets (precision collets System KPS available from Ø 0.5 up to 16 mm).

High clamping forces and concentricity lead to top surfaces and longer tool life.

Plain clamping nut without grooves for high speed machining.

Slim version.



Tool shanks:

Cylindrical DIN 1835-1 form A/DIN 6535 form HA, tolerance h_8 .

Dedicated clamping size on the nominal diameter. Collets available in steps of 0.5 mm.

Run-out:

Maximum runout when measured at a gauge projection of $4 \times d$ in relation to the external taper is $5 \mu\text{m}$.

Balancing:

Fine balancing is standard (G 2.5 30,000 min^{-1}).

Note:

KPS-system chucks are delivered as standard without stop end screws. The use of stop end screws is not recommended at high spindle speeds, e.g. over 10,000 rpm.

Collet chuck size	Capacity d mm	D	L ₁	M	S	Max. tightening torque	D type clamping system max. Rpm*
D16	1 – 10	27	19	M20 × 1	24	40 Nm	60,000
D24	2 – 16	36	22	M28 × 1	32	70 Nm	40,000

* The maximum rpm for holders equipped with this clamping system is often restricted by the holder's back-end taper type and size.



Transmittable static torque to the tool shank (Nm)

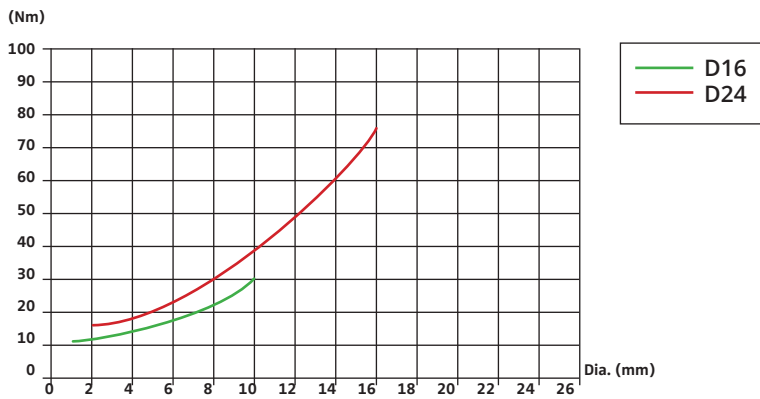

Assembly advice for KPS-system collets with a collet extractor

1. Remove the nut from the chuck.
2. Insert and squeeze the collet into the collet extractor.*
3. Insert the unit collet + ring into the nut until stop end.
4. Push the back end of the collet to remove the unit collet + nut from the ring.
5. Mount the nut together with the collet on the collet chuck.



To dismantle, push unit collet + nut into the collet extractor in order to squeeze the collet. Remove the nut.

Finally, push the back end of the collet to remove it from the collet extractor.

The collet must always be inserted into the nut, and the nut screwed onto the chuck before introducing the tool into the collet.

Never lock the nut without a tool shank located in the full length of the collet.



KPS-Collet



KPS-Collet extractor



KPS-Collet nut



KPS-Wrench



The high-performance milling chucks are suitable for almost all applications. Especially in heavy roughing we guarantee unsurpassed high clamping forces and high process reliability. HKS power chucks lead through the rigidity of the chuck, its concentricity and clamping even at 3 mm from nose lining to excellent surface finish and high tool life. All HKS chucks grant a maximum deviation of concentricity of 3 µm at 3 x D.

Application:

- heavy roughing
- finish milling
- hard milling
- drilling, reaming
- thread milling

Concentricity:

Max. deviation of concentricity 3 µm at 3 x D of the clamped tool.

Balancing:

standard fine-balanced (G 6,3 15.000 min⁻¹).

Clamping shank:

All available tool shanks with or without Weldon shank can be clamped directly or with an adapter sleeve.

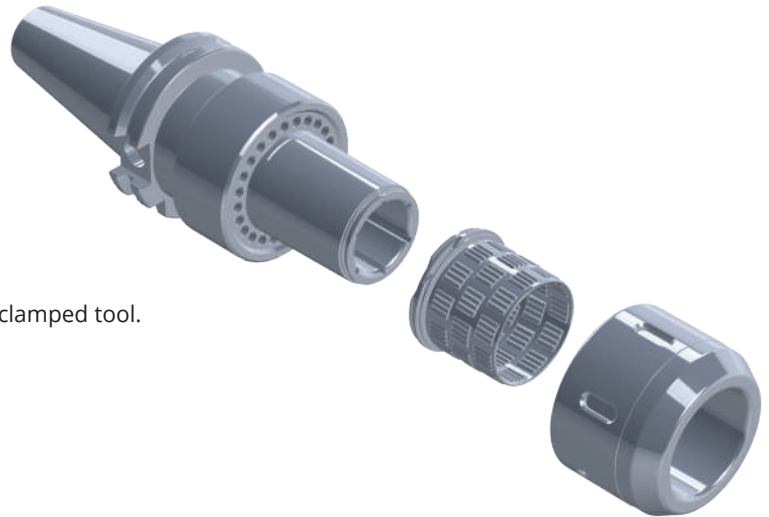

Size	20mm	25mm	32mm
Clamping torque	50-70 Nm	80-100 Nm	80-100 Nm
Clamping force	780 Nm	2000 Nm	2000 Nm



RELEASE THE BEAST





*Enforced body:
Ensures ultimate stability and better axial and radial rigidity*

Plain clamping nut without grooves for high speed machining



Precision ER



Short

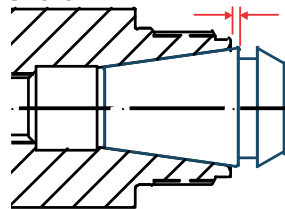

Standard ER



Long

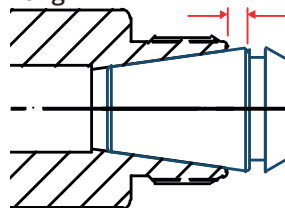

KEMMLER Precision collet chuck:
The deeper seat of the collet in the chuck leads to more precise concentricity and a clear plus in radial stability. Extreme holding forces (increases the holding force by at least 60 % compared to standard ER collet chucks).



Laser engraving of toolholders



Laser engraving of toolholders

With our newly acquired laser engravers we can offer you individual and cost-effective engraving of tools. The permanent engraving can include your company's name, logo or any other special description. Also the labels on the packaging can be designed according to your specifications.





Example:

40 3 . 02 . 20 . 1

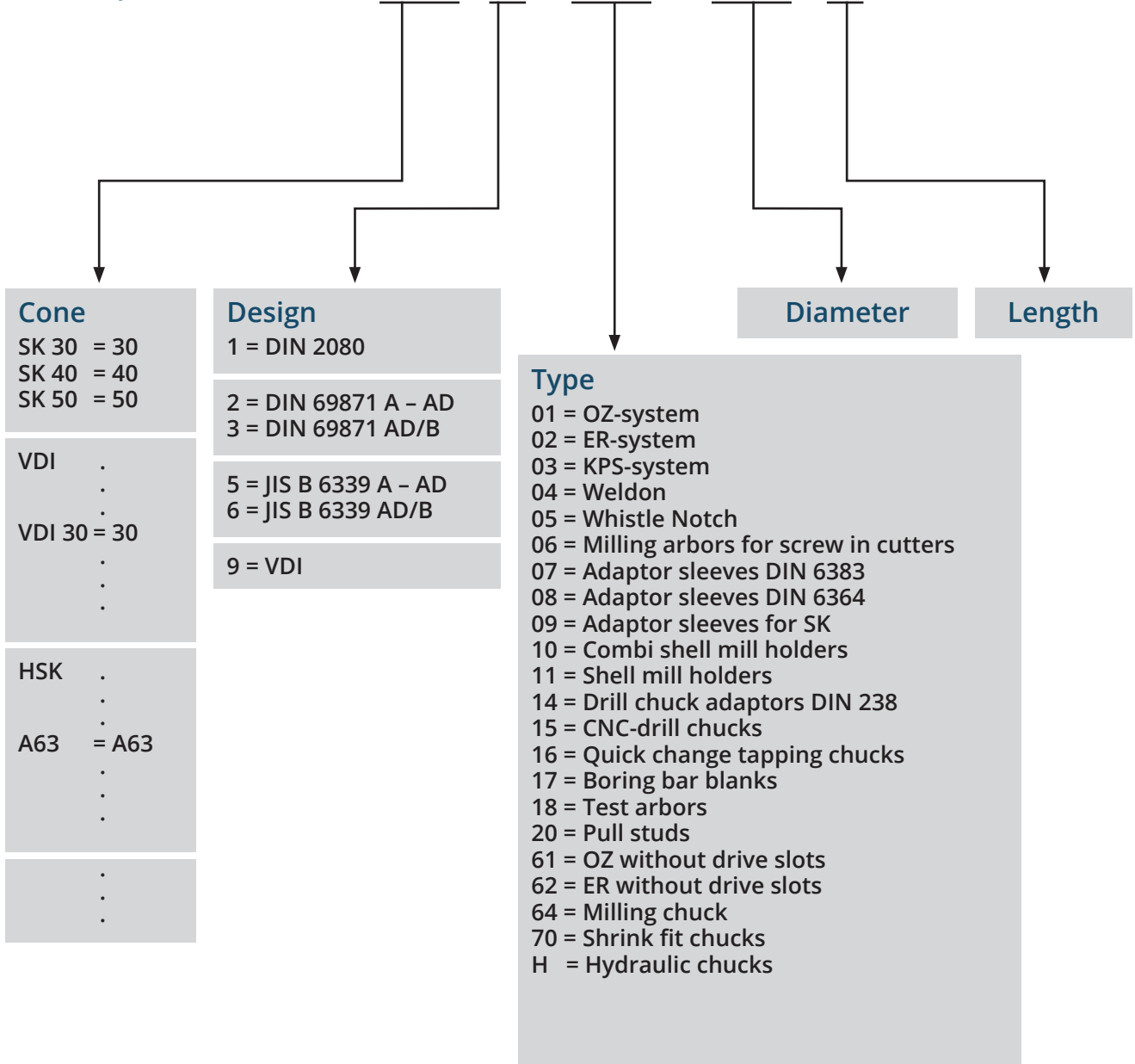



Tool parameters according to ISO 13399

This catalogue was created in accordance with ISO 13399 „Tool data representation and exchange“ in order to enable easy handling of tool and product data.

Here you will find a list of the ISO attributes and feature names used in our catalogue.
A complete listing of tool parameters according to ISO/TS 13399 can be found on our website.

ISO attribute	Feature Description
ISO 13399	English
ADJRGA	Adjustment range, axial
BD	Body diameter
BHTA	Body half taper angle
BTED	Body taper end diameter
CND	Coolant entry diameter
CNT	Coolant entry thread size
CRKS	Pull stud thread size
CTWS	Connection text workpiece side
CXD	Coolant exit diameter
CXT	Coolant exit thread size
DCF	Functional diameter
DCONMS	Mounting Ø, machine side
DCONWS	Clamping Ø, nominal, workpc. side
DF	Flange diameter
DLN	Diameter lock nut
DMIN	Minimum bore diameter
DRVS	Drive size
FLGT	Flange thickness
HF	Functional height
HLN	Lock nut height
HTB	Body height
LB	Body length
LBD	Length body diameter
LCOL	Collet length
LCOMP	Length compensation compression
LDRED	Reduced body diameter length
LF	Functional length
LFSF	Distance to face
LH	Head length
LPR	Protruding length
LS	Shank length
LSC	Clamping length machine side
LSCN	Clamping length minimum machine side
LSCX	Clamping length maximum machine side
OAH	Overall height
OAL	Overall length
OAW	Overall width
PHD	Premachined hole diameter
RADH	Radial body height
RADW	Radial body width
RADWOF	Radial offset width
SZID	nominal size
TD	Thread diameter
TDCON	Tolerance class connection diameter
THID	Thread designation inside
THL	Thread cutting part length
THOD	Thread designation outside
THSZMS	Connection thread nominal size
THSZWS	Connection thread nominal size workpiece side
TP	Thread pitch
TQX	Torque maximum
WF	Functional width



Cône trempé _____	13.61
Tirettes _____	13.62
HSK (cône face creux) _____	13.63
Sommaire HSK (cône face creux) _____	13.65
Canules de lubrification HSK _____	13.66
Effets d'équilibrage sur les broches, les attachements et les outils _____	13.67
Mandrins expansibles hydrauliques _____	13.69
Mode d'emploi pour mandrins expansibles hydrauliques _____	13.70
Couples pour le serrage des fraises Weldon _____	13.71
Mode d'emploi pour mandrins de perçage CNC _____	13.72
Mode d'emploi pour pinces de serrage selon ISO 15488 (DIN 6499) _____	13.73
Notice de montage des joints _____	13.74
Mandrins de taraudage _____	13.75
Instructions d'utilisation des appareils à tarauder _____	13.76
Dimensions de la tige de taraud _____	13.77
Assignation des outils pour machines avec tourelle à disque _____	13.78
Mandrins à pinces de précision système KPS _____	13.79
Mandrin de serrage à haute performance système HKS _____	13.81
Mandrin à pinces ER de précision pour pinces système ER _____	13.83
Marquage laser de porte-outils - KEMMLER OEM - _____	13.84
Le déchiffrage des références Kemmler _____	13.85
Système de codification ISO _____	13.86





De nombreuses machines manuelles ou CNC on utilisent des attachements qui ont été créés précisément avec un cône mâle qui s'emboîte dans le cône femelle de la machine. Il y a également un moyen de sécuriser l'attachement avec une tirette. Celle-ci est plus utilisée avec les machines CNC puisqu'elle permet le changement automatique d'outil plus facilement.

Porte-outil se compose de cinq éléments:

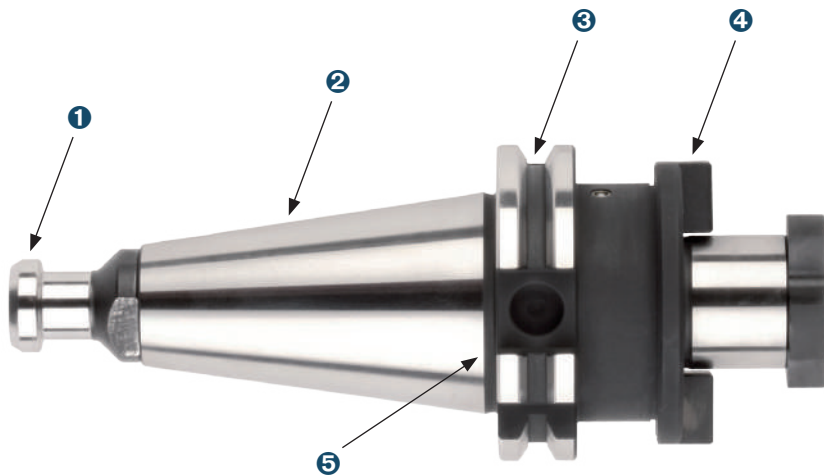

- ❶ Tirette
- ❷ Queue conique
- ❸ Collerette : rainure périphérique en V
- ❹ Adaptateur
- ❺ Rainure opposée

Queue conique

La norme définit six tailles de queues coniques qui comprennent SK 30, SK 35, SK 40, SK 45, SK 50, et SK 60.

La queue conique appropriée selon le type de machine

- ISO 60 une très grande machines
- ISO 50 machines de taille moyenne
- ISO 40 machines de taille petite
- ISO 30 machines très petites

Arrosage forme AD/B

Porte-outils en forme AD/B disposent d'un arrosage interne. Chez la forme B (arrosage par la collerette) il faut enlever les deux bouchons d'étanchéité et utiliser une tirette sans perçage. Chez la forme AD (arrosage centrale) il faut laisser les deux bouchons d'étanchéité dans la collerette et utiliser une tirette percée.

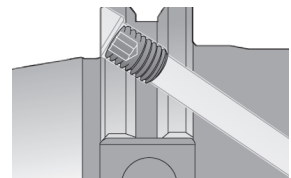

Les boulons de serrage sont un lien important entre la machine et l'outil.

Le boulon de serrage permet à la barre de serrage de la broche de tirer fermement le porte-outil dans la broche et de l'éjecter automatiquement.

Les boulons de serrage existent en différents modèles et tailles. Ils ne sont pas interchangeables entre eux. Outre les boulons de serrage conformes à la norme DIN ISO 7388-3 (anciennement DIN 69872), il existe une multitude de normes d'usine spécifiées par les fabricants.

Utilisation :

- pour les outils à queue conique ISO 7388-1 et ISO 7388-2 [anciennement DIN 69871 et JIS B 6339 (MAS-BT)]
- dans les centres d'usinage (machines avec changeur d'outil de la manière automatique)
- dans les machines numérique (machines sans changeur d'outils automatique)
- pour les outils avec arrosage axial
- pour les outils sans ou avec arrosage axial

Utiliser uniquement les tirettes qui sont spécifiées par le fabricant de la machine.

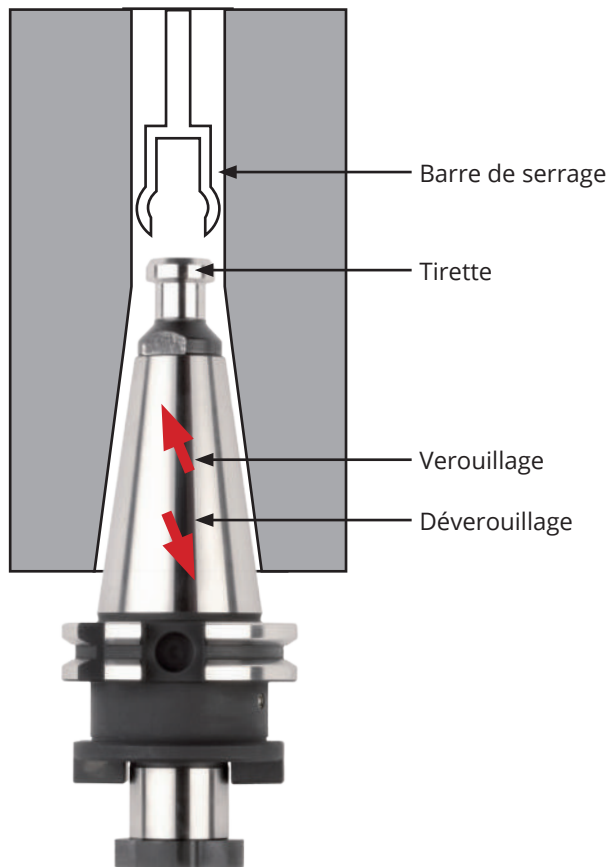

Couple de serrage recommandé pour le montage de tirettes:

SK / BT / ISO 30	20 Nm
SK / BT / ISO 40	50 Nm
SK / BT / ISO 50	100 Nm



Remarques selon les normes:

Sous le titre principale „Queueus d'outils avec cône 7/24 pour changement automatique d'outil“, la norme DIN ISO 7388 est composée des parties suivantes :

- Partie 1 : dimensions et désignation des queues des formes A, AD, AF, U, UD et UF.
- Partie 2 : dimensions et désignation des queues des formes J, JD et JF.
- Partie 3 : d'outons de retenue pour les queues des formes AC, AD, AF, UC, UD, UF, JD et JF.

DIN ISO 7388-3

Queueus d'outils avec cône 7/24 pour changement automatique d'outil
Partie 3: tirettes pour queueus de formes AC, AD, AF, UC, UD, UF, JD et JF
(ISO 7388-3:2013)

DIN ISO 7388-3 remplace DIN 69872:1988-07



Porte-outils HSK DIN 69893

Le cône face creux (HSK) s'était établi depuis la standardisation comme interface entre la machine-outil et l'outil.

Les avantages des outils HSK:

- Rigidité hautement statique et dynamique
- Reproductibilité axiale et radiale de haute précision
- Exactitude invraisemblable aux changements répétés
- Bon comportement à haute vitesse
- Temps de changement extrêmement courts
- Codification, identification
- Alimentation de la lubrification

Conseils d'équilibrage et limites des vitesses de rotation

Porte-outils HSK de Kemmler sont pré-équilibré de principe à G 6,3 15.000 tr./mn.

Équilibrage fin si besoin est possible.

La vitesse de rotation est le facteur le plus important qui influence considérablement le comportement des broches, attachements et roulements dont les limites sont connues et c'est pourquoi lors de la normalisation des HSK les vitesses de rotation maximales ont été retenues:

HSK-A/C 32 jusqu'à 30.000 tr./mn

HSK-A/C 40 jusqu'à 30.000 tr./mn

HSK-A/C 50 jusqu'à 30.000 tr./mn

HSK-A/C 63 jusqu'à 25.000 tr./mn

HSK-A/C 80 jusqu'à 20.000 tr./mn

HSK-A/C 100 jusqu'à 16.000 tr./mn

En fonction de l'outil et à la vitesses de rotation maximales, il est parfois nécessaire d'équilibrer le mandrin et l'outil ensemble. Des valeurs précises à ce sujet ne peuvent être déterminées que si la machine et la broche de la machine on été prises en considération ainsi que le type d'outil et sa longueur dépassant le mandrin de serrage.

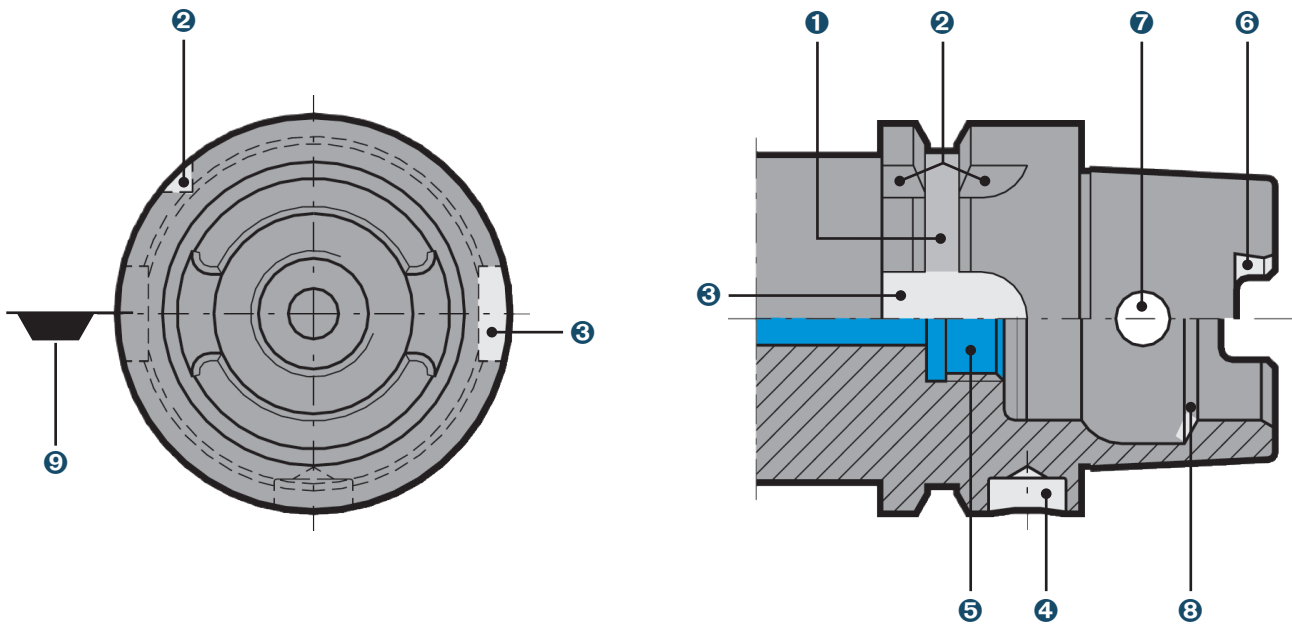

Définition des mots techniques de l'attachement automatique HSK-A

- ❶ Colerette : rainure périphérique en V
- ❷ Rainure d'indexage : rainure transversale sur colerette
- ❸ Rainure d'entraînement, d'indexage et de prise sur l'échangeur.
Pour les formes HSK B et D, afin d'assurer le couple.
- ❹ Cavité : emplacement pour le microprocesseur
- ❺ Perçage et filetage : montage de l'adducteur de la lubrification centrale
- ❻ Rainures sur le cône : renforçant l'entraînement du système
- ❼ Orifice radial : passage de la clé pour le serrage manuel
- ❽ Gorge de préhension :
chanfrein incliné servant d'appui aux mors de serrage
- ❾ Position de la lame d'outil chez outils à un seul tranchant



DIN 69063-1 (ISO 12164-1) Forme A

Type standard pour les centres d'usinage et les fraiseuses. Cône à tige creuse pour changement d'outil automatique avec rainure de préhension et rainure d'indexage. Possibilité d'actionnement manuel grâce au trou d'accès dans le cône. Alésage de réception pour support de données DIN STD 69873 dans la bride. Le couple est transmis par adhérence et par liaison de forme.

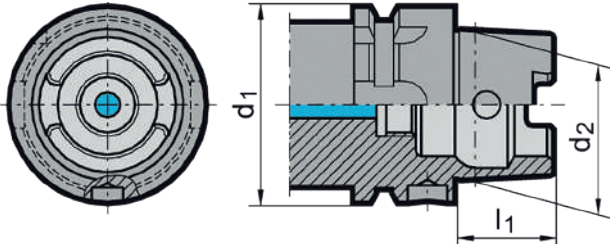

DIN 69063-2 (ISO 12164-1) Forme B

Pour les centres d'usinage, les fraiseuses et les tours. Avec la taille de bride agrandie pour l'usinage stable. Pour le changement d'outil automatique. Alimentation en liquide de refroidissement par la bride. Logement pour le support de données DIN STD 69873 dans la bride.

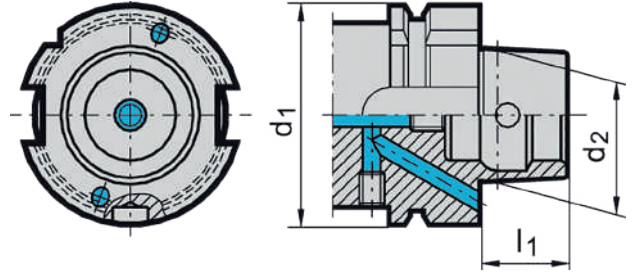

DIN 69063-1 (ISO 12164-1) Forme C

Pour les lignes de transfert, les machines spéciales et les systèmes d'outils modulaires. Cône à tige creuse pour le changement d'outil manuel. Actionnement par un trou d'accès dans le cône. Comme tous les porte-outils de forme A sont équipés de trous latéraux pour le changement manuel d'outil, ils peuvent également être utilisés comme porte-outils de la forme C. Le couple est transmis par adhérence et par liaison de forme.

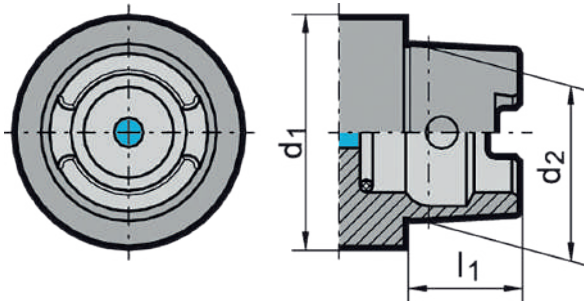

DIN 69063-2 (ISO 12164-2) Forme D

Pour les machines spéciales. Avec une taille de bride agrandie pour l'usinage stable. Pour le changement d'outil manuel. Arrosage par la bride

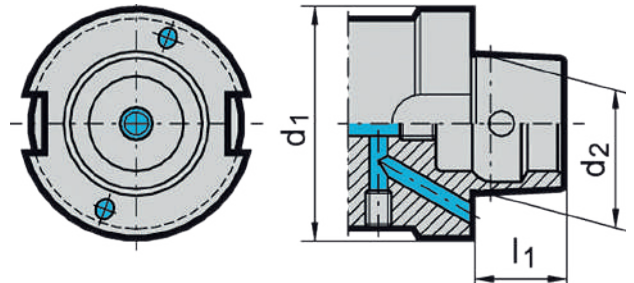

DIN 69063-5 Forme E

Pour l'usinage à grande vitesse. Cône à queue creuse pour le changement d'outil automatique. Le couple est transmis par adhérence. Version avec trou d'accès selon DIN 69893-1 sur demande.

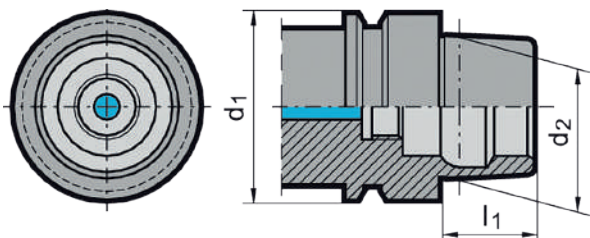

DIN 69063-6 Forme F

Pour les usinages à grande vitesse, principalement dans l'industrie de transformation du bois. Cône à queue creuse pour le changement d'outil automatique. Avec la taille de bride agrandie pour l'usinage stable. Le couple est transmis par adhérence. Version avec trou d'accès selon DIN 69893-1 sur demande.

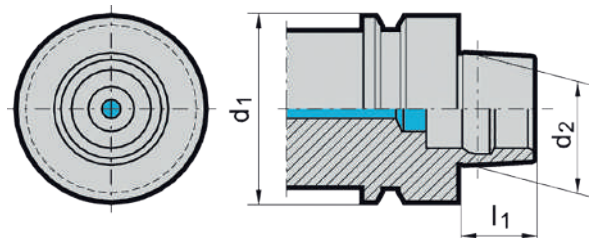

En cas d'usinage avec refroidissement interne, les attachements HSK de la forme A doivent être équipés d'un tube de refroidissement.

Si les outils avec arrosage interne sont utilisés sans canules de lubrifications, la broche peut être endommagée.

Pour DIN 69893 forme C, -E et -F, aucun tube de refroidissement est nécessaire. L'alimentation centrale en liquide de refroidissement ou l'étanchéité est assurée par l'unité de serrage.

Le montage des tubes de refroidissement s'effectue idéalement dans le sens vertical - de bas en haut. Cela permet d'éviter que la bague d'étanchéité ne glisse ou ne soit écrasée lors du vissage et ne perde ainsi sa fonction d'étanchéité.

Le tube de refroidissement est mobile au minimum ($\pm 1^\circ$) après le montage, conformément à la norme DIN.

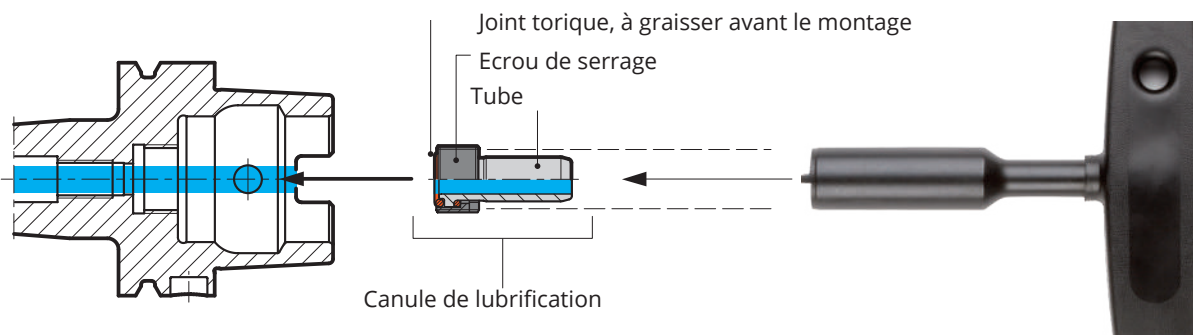

Montage

1. L'outil HSK doit être propre et sans copeaux et en bon état
2. Graisser les joints toriques avant le montage
3. Introduire complètement le jeu du transfert de liquide de refroidissement (tube de liquide de refroidissement, écrou-raccord et 2 joints toriques) dans le HSK en le centrant à l'aide de la clé à douille
4. Visser le jeu/l'unité de la canule de lubrification et la serrer à fond (couple de serrage, voir le tableau à droite)
5. Vérifier la mobilité radiale du tube de lubrification

Couple de serrage

pour HSK	Mt (Nm)
32	7
40	11
50	15
63	20
80	25
100	30



Le déséquilibre

Le déséquilibre génère la force centrifuge sur la broche qui est en rotation, ce qui perturbe la stabilité de fonctionnement d'outil. Ce déséquilibre l'influence le processus de travail et la durée de vie du palier de la broche. La force centrifuge F croît de manière linéaire avec le balourd U et de la manière quadratique avec la vitesse de rotation selon la formule ci-dessous.

Equilibrage

Pour pouvoir compenser les forces centrifuges indésirables, la répartition symétrique des masses doit être rétablie, l'objectif est qu'aucune force centrifuge n'agisse sur le palier de la broche. Il est courant d'utiliser les trous de compensation ou les surfaces de compensation pour les porte-outils. Ainsi la somme de toutes les forces centrifuges agissant sur l'axe tend vers le zéro (voir DIN ISO 1940).

Décalage du centre de gravité

Le déséquilibre d'un arbre déplace son centre de gravité d'une distance par rapport à l'axe de rotation, vers le déséquilibre. Cette distance du centre de gravité est également appelée excentricité résiduelle e ou le déplacement du centre de gravité. Plus la masse d'équilibrage m est grande, plus le déséquilibre résiduel admissible U peut être grand aussi.

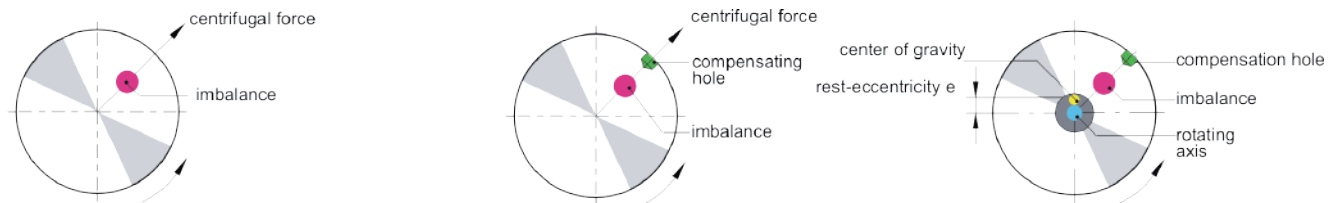

Calcul de déséquilibre

Le déséquilibre est la mesure qui indique combien de masse répartie de manière asymétrique est éloignée de l'axe de rotation dans la direction radiale. Le déséquilibre est indiqué en gmm. La mesure de distance e indique à quelle distance le centre de gravité d'une pièce se trouve de l'axe de rotation.

Le déséquilibre résulte:

$$U = m \times r$$

U = déséquilibre en gmm

e = distance du centre de gravité en μm

m = masse en kg

Limites d'équilibrage

Conformément à la norme DIN ISO 1940, la qualité d'équilibrage est désignée par G ainsi que par les unités gmm/kg ou μm et est liée à la vitesse de rotation. Pour la vitesse de rotation de 15 000 tr/min et le poids de 1 kg, G 6,3 correspond au désalignement admissible entre l'axe de rotation et l'axe du centre de gravité de la broche de 4 μm . Avec la vitesse de rotation double de 30 000 tr/min, cela représenterait 2 μm . Si le porte-outil ne pèse plus que la moitié, soit 0,5 kg, la tolérance d'équilibrage admissible est également divisée par deux. L'objectif de l'équilibrage doit être suivant: trouver un compromis entre ce qui est techniquement faisable et ce qui est économiquement raisonnable. Car la précision radiale de la changement peut déjà atteindre 2 à 3 μm pour l'attachement HSK neuf et 5 à 10 μm pour l'attachement SK, cela signifie déjà la limite de qualité de G 2,5 ou G 6,3 à 10 000 tr/min.

Le graphique ci-dessous montre les niveaux de qualité selon la norme DIN ISO 1940-1, c'est-à-dire les balourds résiduels admissibles rapportés à la masse de l'élément d'équilibrage pour différentes qualités d'équilibrage G en fonction de la vitesse de rotation maximale de fonctionnement.

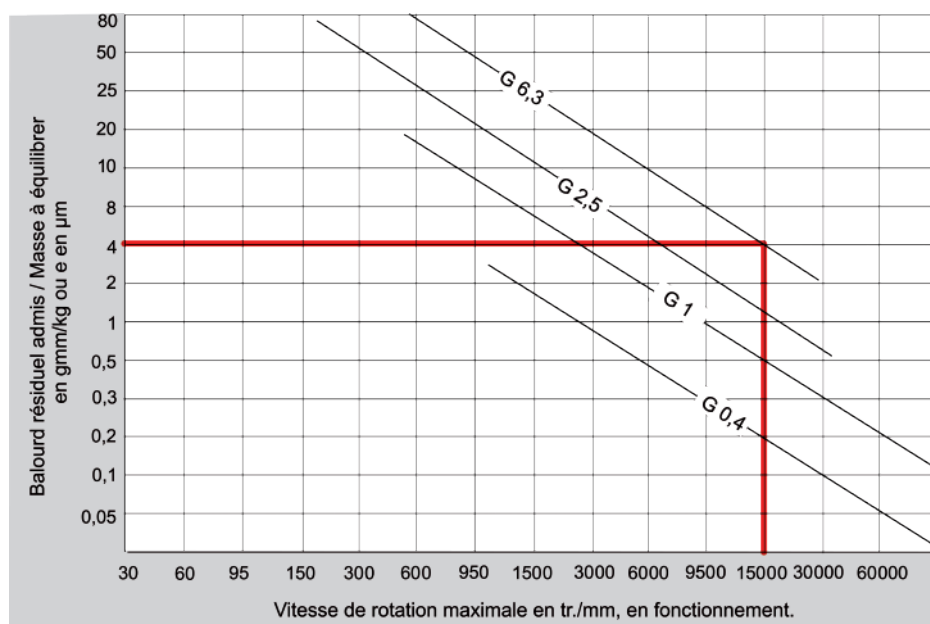

Les porte-outils KEMMLER sont équilibrés selon G 6,3 / 15.000 tr/mn.

Équilibré fin grâce aux trous dans la rainure de préhension



Pré-équilibrage grâce aux trous d'équilibrage sur la collerette

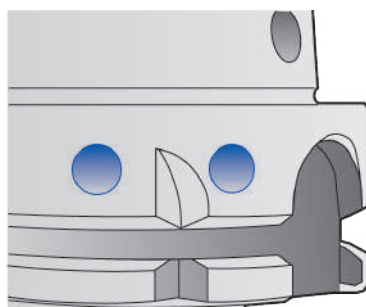

Pré-équilibré grâce à la surface d'équilibrage sur le corps d'outil

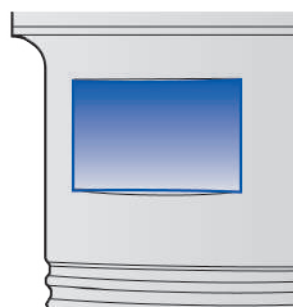



Les processus d'usinage modernes posent des exigences particulières aux porte-outils. Les mandrins de serrage hydraulique offrent donc une bonne tenue, associée à la concentricité précise. De plus ils permettent le changement facile et rapide des outils.

En tournant la vis de pression, on obtient la pression nécessaire dans la chambre de pression. Cette pression entraîne la déformation élastique de la douille de serrage extensible. L'outil est ainsi serré avec de la force - et ceci avec la concentricité exacte. Cela garantit l'ajustement sûr et solide. Si l'on utilise des douilles de réduction qui peuvent accueillir différents diamètres d'outils, l'utilisation des outils peut être étendue à volonté. Profondeur minimale d'enforcement des attachements dans le mandrin!



Avantages

- Serrage précis d'outil avec l'erreur de concentricité de 3 µm max.
- Transmission de couples élevés par le système optimisé de douilles de dilatation (tension élevée)
- Adapté à la grande vitesse (pas de forces centrifuges grâce aux segments de serrage)
- Rotation exacte, d'où l'excellente qualité de la surface et le respect des dimensions de la pièce à usiner
- Changement d'outil rapide grâce aux vis de serrage facile à actionner
- Durée de vie optimale des outils
- Effet d'amortissement des vibrations grâce à l'hydro-polissage

Données techniques

Serrage Ø [mm]	Couple de serrage [Nm]	Profondeur de serrage minimale [mm]	Transmissible couple max. pour la tige dimension min. h6 [Nm]	Tige tolérance	max. RPM [min-1]	
					LPR ≤ 125 mm	LPR > 125 mm
6	10	27	12	h6	40.000	20.000
8	10	27	30	h6	40.000	20.000
10	10	31	40	h6	40.000	20.000
12	10	36	70	h6	40.000	20.000
14	10	36	100	h6	40.000	20.000
16	10	39	135	h6	40.000	20.000
18	10	39	180	h6	40.000	20.000
20	10	41	220	h6	40.000	20.000
25	10	47	500	h6	20.000	10.000
32	10	51	700	h6	20.000	10.000

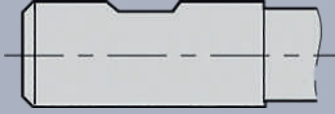
Serrage des attachements d'outils selon la norme DIN 6535 dans les mandrins expansibles hydrauliques

DIN 6535 DIN 1835-1	Ø 6 - 20 mm	Ø 25 - 32 mm	Utilisation de manchons de réduction
 Form HA	✓	✓	✓
 Form HB/ E	✓	✗	✓
 Form HE/ E	✗	✗	✓
Run out (↗)	≤ 0,003 mm		≤ 0,005 mm



Pour garantir le bon fonctionnement des mandrins de serrage hydro expansibles, veuillez respecter les instructions suivantes:

L'utilisation d'outils à queue cylindrique selon DIN 1835 et DIN 6535 forme (HA) et B (HB) jusqu'au Ø 20 mm queue de serrage avec la tolérance de fabrication h6, rectifiée finement $Ra_{min} = 0,3$.

Les queues selon DIN 6535 version HE (Whistle Notch) peuvent être utilisées qu'avec les réductions. Tous les mandrins de serrage hydrauliques sont pré-équilibrés par le fabricant à G6,3 15.000 min-1.

Serrage et desserrage des outils

1. Nettoyer l'alésage du mandrin et la queue d'outil de la graisse et de la saleté. Mettre la tige d'outil dans la position jusqu'à la butée. Veuillez respecter la profondeur d'insertion et la course de réglage.
2. Tourner la vis de serrage dans le sens des aiguilles d'une montre jusqu'à la butée à l'aide de la clé hexagonale. L'outil est serré. En cas de risque de rupture de la douille de serrage par extension, ne pas effectuer le serrage à vide.
3. Pour desserrer l'outil, dévisser la vis de serrage environ 5 à 6 tours et retirer l'outil.

Remarque : ne jamais serrer sans un outil fixé !

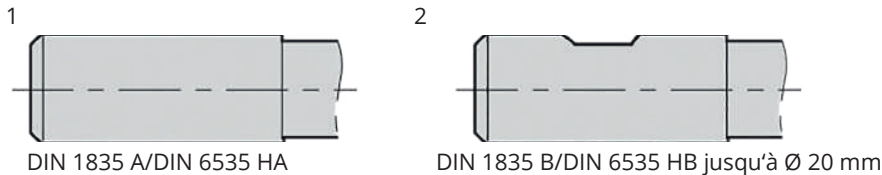

Nettoyage

Faire attention à la propreté de l'alésage de réception et de la tige de l'outil.

Température

La température optimale entre 10 et 50 °C. Ne pas utiliser avec plus que 80 °C.

Stockage

Mandrin de serrage hydro-expansible desserré, stocker modérément huilé.

Tiges de serrage

Ne serrer que les queues d'outils DIN 1835 forme A et forme B (jusqu'à 20 mm).

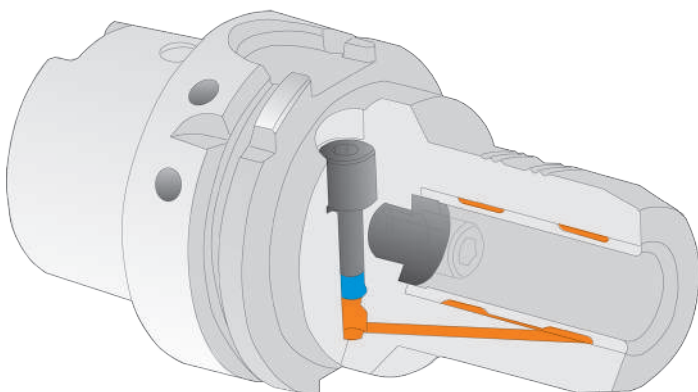

K Couples pour le serrage des fraises Weldon dans porte-fraises DIN 6359



La plus grande précision de concentricité avec les couples définis pour les tiges Weldon:



Couples pour DIN 1835

Perçage	Vis		Couple
Ø 6 mm	M 6	SW 3	10 Nm
Ø 8 mm	M 8	SW 4	10 Nm
Ø 10 mm	M 10	SW 5	16 Nm
Ø 12 mm	M 12	SW 6	28 Nm
Ø 14 mm	M 12	SW 6	28 Nm
Ø 16 mm	M 14	SW 6	42 Nm
Ø 18 mm	M 14	SW 6	42 Nm
Ø 20 mm	M 16	SW 8	50 Nm
Ø 25 mm	M 18 × 2	SW 10	60 Nm
Ø 32 mm	M 20 × 2	SW 10	72 Nm
Ø 40 mm	M 20 × 2	SW 10	72 Nm
Ø 50 mm	M 24 × 2	SW 12	90 Nm
Ø 63 mm	M 24 × 2	SW 12	90 Nm

Les limites de charge du logement de la broche doivent être respectées

Température d'exploitation : + 20 °C ... + 50 °C

La pression max du liquide de refroidissement: 80 bar

Ø de serrage	Max. tours en m ⁻¹		Couple de serrage max.	Vis de serrage	SW	Ø de queue en mm
	LPR jusque 125mm	LPR par 125mm				
Ø 6 mm	50.000	30.000	10 Nm	M 6	SW 3	Ø 6 h6
Ø 8 mm	50.000	30.000	10 Nm	M 8	SW 4	Ø 8 h6
Ø 10 mm	50.000	30.000	16 Nm	M 10	SW 5	Ø 10 h6
Ø 12 mm	50.000	30.000	28 Nm	M 12	SW 6	Ø 12 h6
Ø 14 mm	50.000	30.000	28 Nm	M 12	SW 6	Ø 14 h6
Ø 16 mm	50.000	30.000	42 Nm	M 14	SW 6	Ø 16 h6
Ø 18 mm	50.000	30.000	42 Nm	M 14	SW 6	Ø 18 h6
Ø 20 mm	50.000	30.000	50 Nm	M 16	SW 8	Ø 20 h6
Ø 25 mm	25.000	20.000	60 Nm	M 18 × 2	SW 10	Ø 25 h6
Ø 32 mm	25.000	20.000	72 Nm	M 20 × 2	SW 10	Ø 32 h6



Serrage et desserrage des outils

Afin de garantir le bon fonctionnement des mandrins de perçage CNC 08 / 13 / 16 veuillez suivre les instructions suivantes :

Attention :

L'outil ne doit être serré que lorsque la broche est à l'arrêt ou à l'extérieur de la machine.

Le mandrin de perçage CNC (pos. 1) est serré sur le côté par l'entraînement conique à l'aide d'une clé à poignée transversale hexagonale (pos. 3). Tournez la clé hexagonale dans le sens des aiguilles d'une montre pour serrer le mandrin, dans le sens inverse pour l'ouvrir.

1-ère étape

Ouvrez bien les mors du mandrin pour insérer l'outil de découpage (pos. 2).

2-ème étape

L'outil (pos. 2) est inséré jusqu'à la butée dans le mandrin de perçage CNC (pos. 1). (image 1)

3-ème étape

Tournez la clé hexagonale (pos. 3) dans le sens des aiguilles d'une montre avec le couple de serrage de 15 Nm (pour 0,5-8 = 10 Nm) afin de serrer l'outil proprement (image 2).

Attention :

Ne pas utiliser la rallonge ou la clé de serrage. Si le couple de serrage est plus que 15 Nm (pour 0,5-8 = 10 Nm), l'entraînement conique peut être détruit. Dans ce cas, le pignon est le point de rupture afin d'éviter les dégâts graves sur le mandrin.

4-ème étape

Après le serrage assurez vous que l'outil est bien serré dans le mandrin de perçage.

Attention :

Ne pas serrer tige conique - danger d'accident !

5-ème étape

Le mandrin de perçage CNC est prêt à être utilisé et peut être fixé dans la broche de la machine (image 3).

6-ème étape

Pour desserrer l'outil, tournez la clé hexagonale dans le sens inverse des aiguilles d'une montre et retirez l'outil.

Maintenance et nettoyage

Les mandrins de perçage CNC 08 / 13 / 16 n'exigent aucun entretien, mais doivent être nettoyés à l'air comprimé et avec un chiffon propre après leur usage. Le nettoyage avec des solvants peut causer de la rouille. C'est pourquoi il faut vaporiser de l'huile sur le mandrin avant le stockage.

Réparation

En cas de réparation nous vous prions de nous renvoyer le mandrin CNC. Nous remplaçons en générale la tête du mandrin complètement. De cette manière vous recevrez un remplacement au plus vite possible et c'est la seule façon de garantir un bon fonctionnement des mandrins de perçage. Cela garantie un faux rond de <0,03 mm aussi.



Image 1



Image 2

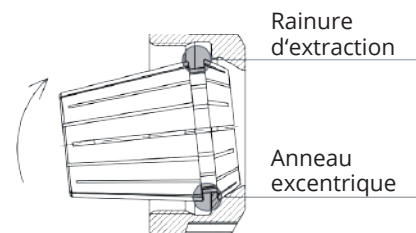

Image 3



Montage:

Accrocher la rainure de la pince de serrage dans la bague excentrique de l'écrou de serrage. Basculer la pince de serrage dans la direction opposée jusqu'à ce qu'elle s'enclenche de la manière la plus audible. Utiliser l'outil. Visser l'écrou de serrage avec la pince de serrage enclenchée sur le filetage du mandrin. Nous recommandons de serrer l'écrou de serrage avec la clé dynamométrique.



Démontage :

Après avoir dévissé le mandrin, appuyer sur la façade de la pince de serrage. En même temps retirer la pince de serrage de l'enclenchement de l'écrou par la pression latérale sur la partie arrière.

Mauvaise utilisation affecte la concentricité de la pince de serrage et peut endommager l'écrou de serrage.

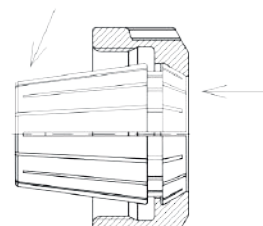

Attention :

Ne monter que des écrous de serrage dont la pince de serrage est correctement enclenchée !

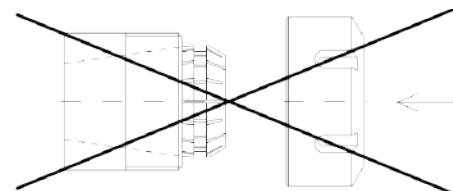

Ne jamais serrer des queues surdimensionnées!

par exemple ne jamais insérer dans la pince de Ø 12-11 mm insérer la tige de Ø 12,2 mm. Utilisez à chaque fois la pince de serrage qui suit la plus grande (ici 13-12 mm).

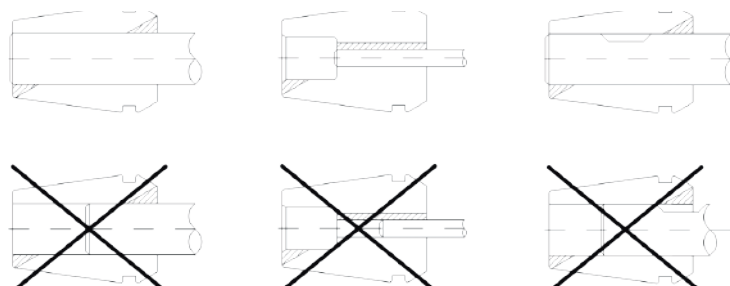

Dans la mesure du possible, serrer la queue de l'outil sur toute la longueur portante de la pince (au moins 2/3 de celle-ci).

Couple maximum

ER 16	M22 × 1,5	50 Nm
ER 20	M25 × 1,5	75 Nm
ER 25	M32 × 1,5	85 Nm
ER 32	M40 × 1,5	105 Nm
ER 40	M50 × 1,5	150 Nm
ER 11 Mini	M13 × 0,75	18 Nm
ER 16 Mini	M19 × 1	28 Nm

Veuillez noter le couple maximum indiqué dans le tableau!

Montage:

Insérer d'abord la bague d'étanchéité avec le plus petit diamètre dans l'écrou de serrage de l'intérieur et augmenter la pression de manière régulière jusqu'à ce que la bague d'étanchéité s'enclenche. La bague d'étanchéité doit être à la même hauteur que la façade de l'écrou de serrage.

Demontage:

Pour retirer la bague d'étanchéité, appuyer de façon régulière sur la bague d'étanchéité de l'extérieur jusqu'à ce qu'elle se détache.

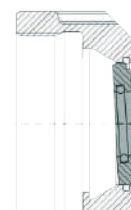
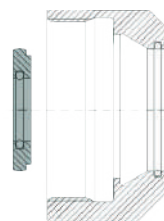



Le processus de taraudage est une combinaison de mouvements radiaux et axiaux. Il est parfois nécessaire de limiter le mouvement axial d'outil.

Si le mouvement axial est mal contrôlé, les pointes de perçage du taraud risquent de couper plus qu'il faut et de produire le filetage trop grand.

Compensation de la longueur (traction) – la compensation permet au taraud de faire un filetage sans que la broche de la machine soit influencé par l'avance axiale.

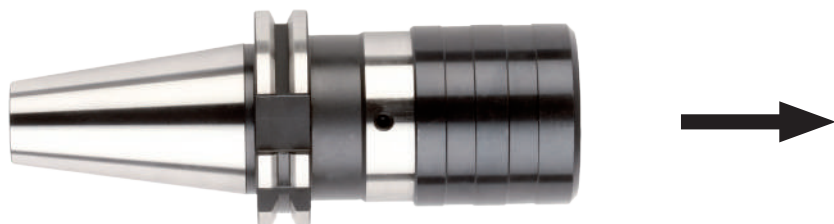

Compensation de la longueur (pression) – la compensation agit comme un coussin et permet le taraud de pénétrer dans le matériel. Cette procédure est également indépendante de l'avancement de la machine.

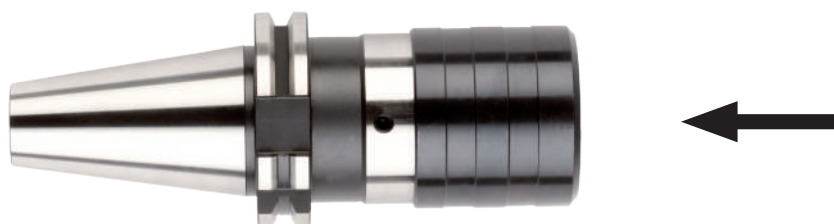

Compensation de la longueur (pression/traction) – le but de la compensation est suivant: compenser toutes les forces externes pendant le processus d'usinage.

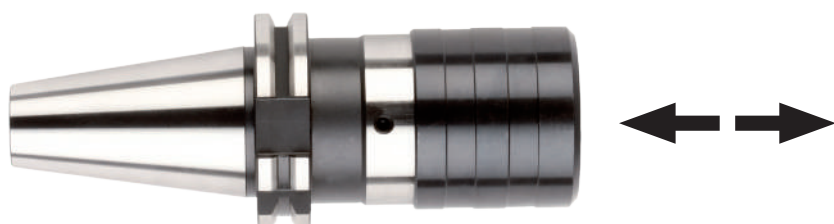

Compensation radiale du pendule – compense la déviation légère de l'axe de la broche de la machine et de l'axe du trou. Il faut l'éviter autant que possible.



Veillez prendre en compte la compensation de longueur en mm déjà avant le premier taraudage. Cela permet d'éviter que les valeurs ne soient dépassées et donc que le mandrin et le taraud ne soient endommagés.



Réf.	Capacité de taraudage	Douille	Compensation	
			pression	traction
xxx.16.12	M 3- M14	16.11.xx / 16.01.xx	7	7
xxx.16.20	M 5 - M22	16.12.xx / 16.02.xx	12	12
xxx.16.36	M14 - M36	16.14.xx / 16.03.xx	17,5	17,5



Diamètre de la queue					
Ø × □	DIN 352	DIN 5157	DIN 371	DIN 374	DIN 376
Ø 2,5 × 2,1 □	M1		M1	M3	M3,5
Ø 2,5 × 2,1 □	M1,1		M1,1	M3,5	
Ø 2,5 × 2,1 □	M1,2		M1,2		
Ø 2,5 × 2,1 □	M1,4		M1,4		
Ø 2,5 × 2,1 □	M1,6		M1,6		
Ø 2,5 × 2,1 □	M1,8		M1,8		
Ø 2,8 × 2,1 □	M2		M2	M4	M4
Ø 2,8 × 2,1 □	M2,2		M2,2		
Ø 2,8 × 2,1 □	M2,5		M2,5		
Ø 3,5 × 2,7 □	M3		M3	M5	M5
Ø 4 × 3 □	M3,5		M3,5		
Ø 4,5 × 3,4 □	M4		M4	M6	M6
Ø 6 × 4,9 □	M5		M5		
Ø 6 × 4,9 □	M6		M6		
Ø 6 × 4,9 □	M8			M8	M8
Ø 7 × 5,5 □	M10	G 1/8"		M10	M10
Ø 8 × 6,2 □			M8		
Ø 9 × 7 □	M12			M12	M12
Ø 10 × 8 □			M10		
Ø 11 × 9 □	M14	G 1/4"		M14	M14
Ø 12 × 9 □	M16	G 3/8"		M16	M16
Ø 14 × 11 □	M18			M18	M18
Ø 16 × 12 □	M20	G 1/2"		M20	M20
Ø 18 × 14,5 □	M22	G 5/8"		M22	M22
Ø 18 × 14,5 □	M24			M24	M24
Ø 20 × 16 □	M27	G 3/4"		M27	M27
Ø 22 × 18 □	M30	G 7/8"		M30	M30
Ø 25 × 20 □	M33	G 1		M33	M33
Ø 28 × 22 □	M36	G 1 1/8"		M36	M36
Ø 32 × 34 □	M39	G 1 1/4"		M39	M39
Ø 32 × 24 □	M42			M42	M42
Ø 36 × 29 □	M45	G 1 3/8"		M45	M45
Ø 36 × 29 □	M48	G 1 1/2"		M48	M48
Ø 36 × 29 □		G 1 3/4"			
Ø 36 × 29 □		G 2"			

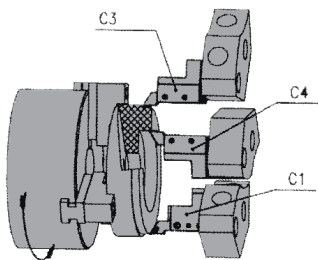

Utilisation de porte-outils radiaux avec le sens de rotation de la broche à gauche

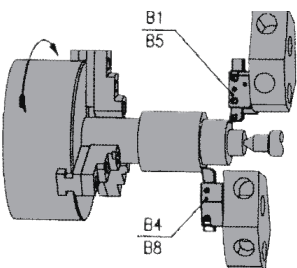

Utilisation de porte-outils radiaux avec le sens de rotation de la broche à droite

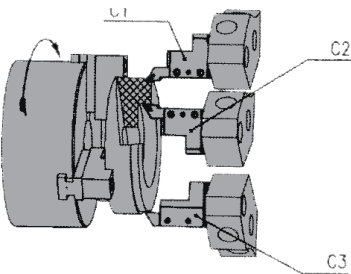

Utilisation de porte-outils axiaux avec le sens de rotation de la broche à gauche

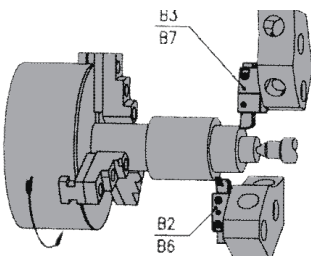

Utilisation de porte-outils axiaux avec le sens de rotation de la broche à droite



Le mandrin à pince de précision Kemmler est une alternative aux mandrins de serrage hydraulique et aux mandrins de freinage.

Flexibilité élevée grâce aux pinces de serrage remplaçables (pinces de serrage de précision système KPS qui sont disponibles de Ø 0,5 à 16 mm).

Les forces de serrage élevées et la précision de la concentricité assurent la surface de haut qualité et la durée de vie des outils plus longue.

Ecrou de serrage lisse sans rainures pour l'usinage à grande vitesse.

Version élancée.



Tige de serrage:

Cylindrique DIN 1835-1 forme A/DIN 6535 forme HA, tolérance h8. Les queues d'outils doivent correspondre aux diamètres nominaux des pinces de serrage. Les pinces de serrage sont disponibles par graduation de 0,5 mm.

Rotation circulaire:

Max. écart de concentricité est 5 µm pour 4×d d'outil serré.

Angle d'inclinaison:

L'angle d'inclinaison de la face de serrage est à 4°, ainsi il n'y a pas de forces radiales pendant le serrage qui peuvent influencer la concentricité.



Équilibrage :

Équilibrage fin dans la version standard (G 2,5 30.000 min-1).

Remarque:

Les mandrins à pinces du système KPS sont livrés en version standard sans vis de butée, car celles-ci ne sont pas conseillées pour les vitesses de rotation élevées.

Taille du mandrin à pince	Capacité d mm	Ø pas en mm	Couple de serrage max.	Système de serrage Type D, tr/mn max.*
D16 (KPS 10)	0,5 – 10	0,5	40 Nm	60.000
D24 (KPS 16)	1,0 – 16	0,5	70 Nm	40.000

* La vitesse de rotation max pour ce type d'outil est limitée par la taille et la forme de la tige conique.

Couple transmissible (Nm) sur la queue d'outil (mesuré statiquement) Nm

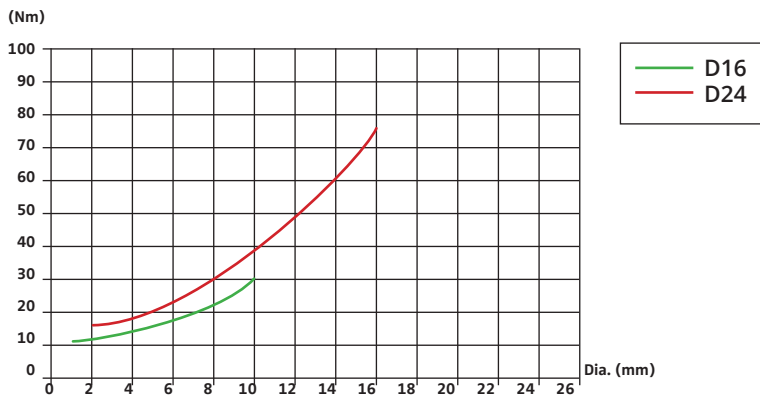

Montage des pinces de serrage KPS:

1. desserrer l'écrou de serrage du mandrin
2. insérer la pince de serrage dans le dispositif d'aide de montage*
3. Insérer la pince de serrage avec le dispositif d'aide de montage jusqu'à la butée dans l'écrou de serrage
4. Déclencher le dispositif d'aide de montage
5. Monter l'écrou de serrage avec la pince de serrage dans le mandrin



Demontage

Insérez la pince de serrage avec l'écrou de serrage dans le dispositif d'aide de montage pour serrer la pince de serrage.

Ensuite retirer l'écrou de serrage.



Pinces de serrage



Moyen d'assemblage



Ecrous de serrage*



Clés de serrage*

* breveté



Les mandrins à pinces Kemmler de haute précision sont adaptés pour presque toutes les utilisations. Nous garantissons des forces de serrage élevées inédites et la sécurité de processus, en particulier dans l'usinage lourd. Grâce à la dureté du mandrin, à sa précision de concentricité et au serrage à partir de 3 mm de la pointe du mandrin, les mandrins de serrage HKS donnent une excellente finition de surface et la durée de vie des outils avantageuse. Tous les mandrins HKS garantissent le décalage max de la concentricité de 3 µm pour 3 x D.

L'utilisation:

- Usinage lourd
- Fraisage de finition
- Fraisage des surfaces dures
- Perçage, alésage
- Fraisage de filetages

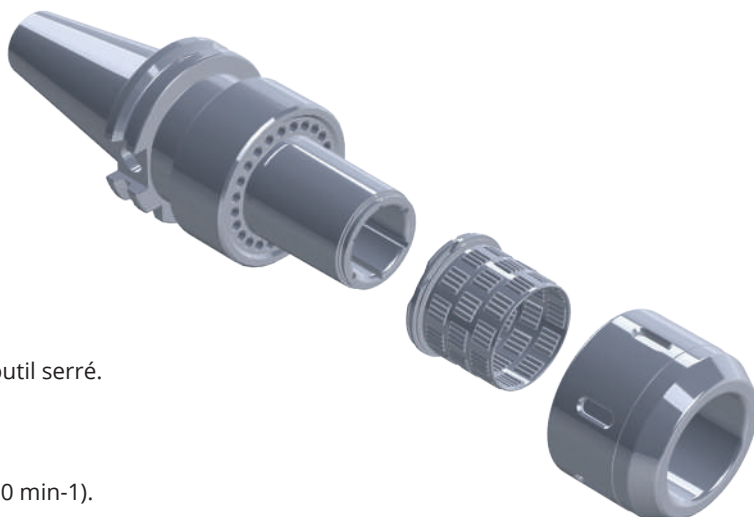

Rotation circulaire:

Le décalage max de concentricité 3 µm pour 3×d d'outil serré.

Équilibrage :

Équilibrage fin dans la version standard (G 6,3 15.000 min-1).

Tige de serrage:

Toutes les tiges d'outils qui sont courants sur le marché, avec ou sans la tige Weldon, peuvent être serrées directement ou avec une douille de serrage.

Taille	20mm	25mm	32mm
Couple de serrage	50-70 Nm	80-100 Nm	80-100 Nm
Force de serrage	780 Nm	2000 Nm	2000 Nm



RELEASE THE BEAST





Corps de mandrin renforcé:
Pour la stabilité et la rigidité radiale plus élevée



Écrou de serrage lisse sans rainures pour l'usinage à grande vitesse



Precision ER



Court

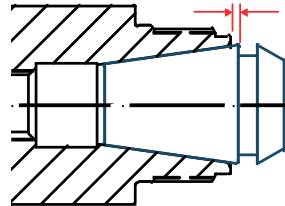

Standard ER



Long

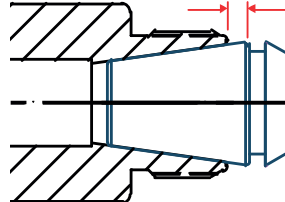

Mandrins à pinces de précision KEMMLER:
Le positionnement plus profond de la pince de serrage dans le mandrin assure la concentricité plus précise et la stabilité radiale plus élevée. La force de maintien extrême (augmentée la force de maintien d'au moins 60 % par rapport aux mandrins à pinces ER standard)

Marquage de porte-outils avec laser



Marquage laser sur les porte-outils

Grâce à nos appareils de marquage à laser nous vous proposons marquage des outils personnalisé et pas coûteux. Le marquage de manière permanente peut être effectué avec le nom ou le logo de votre entreprise ou avec d'autres marques particulières.

En outre les étiquettes sur les emballages peuvent être adaptées à vos besoins.



Paramètres de l'outil selon ISO 13399

Ce catalogue a été créé conformément à la norme ISO 13399 „Représentation et échange de données d'outils“ afin de faciliter l'emploi des données d'outils et de produits.

Vous trouverez ici l'énumération des attributs ISO et les noms de caractéristiques utilisés dans notre catalogue. Vous trouverez une liste complète des paramètres d'outils selon la norme ISO/TS 13399 sur notre site Internet.

Sigle ISO	Désignation
ADJRG	Plage de réglage, axiale
BD	Diamètre du corps
BHTA	Angle de réglage du cône
BTED	Diamètre du cône
CND	Ø D'entrée de liquide de refroidissement
CNT	Valeur du filetage d'entrée pour lubrifiant
CRKS	Taille nominale du filetage
CTWS	Texte de connexion côté pièce
CXD	Ø Sortie de liquide de refroidissement
CXT	Taille du filetage de la sortie du liquide de refroidissement
DCF	Diamètre de coupe face frontale
DCONMS	Ø de queue, côté machine
DCONWS	Ø de serrage, nominal, côté pièce à usiner - Plage
DF	Diamètre de la collerette
DLN	Diamètre extérieur écrou de serrage
DMIN	Ø de perçage, min.
DRVS	largeur sur plat
FLGT	Épaisseur de bride
HF	Hauteur fonctionnelle
HLN	Hauteur de l'écrou de serrage
HTB	Hauteur du corps
LB	Longueur de corps principal
LBD	Longueur Diamètre du corps
LCOL	Longueur sous collerette
LCOMP	Compression de compensation de longueur
LDRED	Longueur, diamètre du corps réduit
LF	Longueur fonctionnelle
LFSF	Distance de face avant
LH	Longueur de tête
LPR	Longueur du porte-à-faux (saillante)
LS	Longueur de la queue
LSC	Longueur de serrage
LSCN	Longueur de serrage, min.
LSCX	Longueur de serrage, max.(prof. d'insertion maxi)
OAH	Hauteur totale
OAL	Longueur hors-tout
OAW	Largeur totale
PHD	Diamètre d alésage pré-usiné
RADH	Hauteur radiale de caisse
RADW	Largeur corps radial
RADWOF	Largeur de l'épaulement radial
SZID	Taille nominale (Taille de système)
TD	Diamètre du filet
TDCON	Classe de tolérance Diamètre de raccordement
THID	Désignation du filetage interieur
THL	Longueur de la partie coupante
THOD	Désignation du filetage
THSZMS	Dimension nominale du filetage, côté machine
THSZWS	Dimension nominale du filetage, côté pièce à usiner
TP	Pas du filetage
TQX	Couple de serrage max.
WF	Largeur fonctionnelle





Ihr Weg zu uns · How to find us · Plan d'accès

Mössingen befindet sich im Bundesland Baden-Württemberg, ca. 50 km südlich von Stuttgart.

Mössingen is situated in the federal state of Baden-Württemberg, approximately 50 km south of Stuttgart.

Mössingen se trouve dans la province Baden-Württemberg, à peu près 50 km au sud de Stuttgart.

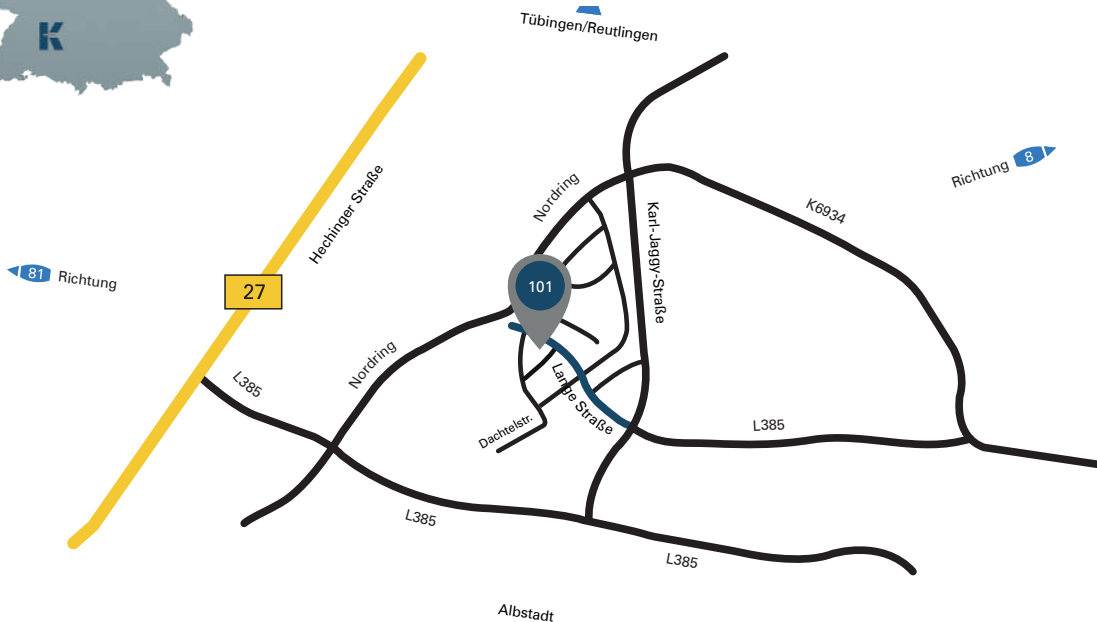

KEMMLER Präzisionswerkzeuge GmbH
Lange Str. 101
72116 Mössingen
Deutschland

Telefon: +49 7473 92408-0
Telefax: +49 7473 92408-20

info@kemmler-tools.de
www.kemmler-tools.de
facebook.com/kemmler



Copyright © 2022 Kemmler Präzisionswerkzeuge GmbH. Alle Rechte vorbehalten.
First Class® ist eine eingetragene Marke der Kemmler Präzisionswerkzeuge GmbH.

Technische Änderungen und Änderungen des Lieferprogramms vorbehalten. Für Druckfehler und Irrtümer keine Gewähr.

Printed in Germany 2022.
Dokumentnummer: 22-364289

Für sämtliche Leistungen gelten unsere jeweils aktuellen Allgemeinen Geschäftsbedingungen, die Sie auch im Internet unter www.kemmler-tools.de einsehen können.

*Copyright © 2022 Kemmler Präzisionswerkzeuge GmbH. All rights reserved.
First Class® is a registered trademark of the Kemmler Präzisionswerkzeuge GmbH.*

Subject to technical changes. No responsibility for errors and printing errors are accepted.

*Printed in Germany 2022.
Document number: 22-364289*

Our terms and conditions apply to all services offered by Kemmler. Please find a current version of our terms and conditions on the internet at: www.kemmler-tools.de

Copyright © 2022 Kemmler Präzisionswerkzeuge GmbH. Tous droits réservés.
First Class® est une marque déposée de la Kemmler Präzisionswerkzeuge GmbH.

Nous nous réservons le droit de procéder à des modifications.
Les erreurs de frappe ou d'impression n'engagent pas notre responsabilité.

Imprimé en Allemagne 2022.
Numéro du document: 22-364289

Nos conditions générales actuelles, qui peut être consulté sur le site Internet www.kemmler-tools.de s'appliquent à tous les services.

KEMMLER Präzisionswerkzeuge GmbH
Lange Str. 101
72116 Mössingen
Germany

Telefon +49 7473 92408-0
Telefax +49 7473 92408-20
info@kemmler-tools.de
www.kemmler-tools.de

Werden Sie Teil der KEMMLER-Community. Folgen Sie uns im Internet:
Become a part of the KEMMLER community. Follow us on the web:
Devenez un membre de la communauté KEMMLER. Suivez-nous sur le web :



linkedin.com/company/kemmler-tools



instagram.com/kemmlertools



youtube.com/KemmlerToolsD



facebook.com/kemmler

Ihr Fachhändler - Your specialist dealer - Votre spécialiste

Netto-Preise pro Stück ab Werk, zzgl. gesetzlicher MwSt.
Net prices per piece ex works, plus VAT at the statutory rate.
Prix nets par pièce au départ de l'usine, plus la TVA au taux légal.